



**THE DATASHEET OF
XR3083XIDTR-F**



GENERAL DESCRIPTION

The XR3080-88X family of high performance RS-485/422 devices are designed for improved performance in noisy industrial environments and increased tolerance to system faults.

The analog bus pins can withstand direct shorts up to $\pm 18V$, and are protected against ESD events up to $\pm 15kV$. The Profibus compliant differential output delivers 40% higher SNR than standard RS-485/422 devices, affording additional noise margin or extended cable lengths.

The receivers include full fail-safe circuitry, guaranteeing a logic-high receiver output when the receiver inputs are open, shorted, or undriven. The receiver input impedance is at minimum $96k\Omega$ (1/8 unit load), allowing up to 256 devices on the bus while preserving the full signal margin.

The drivers are protected by short circuit detection as well as thermal shutdown, and maintain high impedance in shutdown or when powered off. The XR3080-85X drivers are slew limited for reduced EMI and error-free communication over long or unterminated data cables.

The devices with DE and \overline{RE} pins include hot swap circuitry to prevent false transitions on the bus during powerup or live insertion, and can enter a 1nA low current shutdown mode for extreme power savings.

The transceivers draw less than $600\mu A$ from a +5.0V supply, and typically only $300\mu A$ when idling with the receivers active.

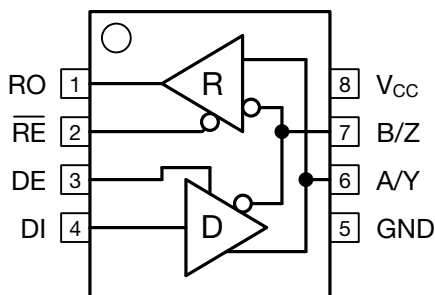

FEATURES

- **40% Higher SNR** (Signal-to-Noise Ratio) compared to other RS-485 devices (2.1V vs. 1.5V)
- **$\pm 18V$ Fault Tolerance** on Analog Bus pins
- **2.1V Driver Output** (Profibus Compliant)
- **Robust ESD** (ElectroStatic Discharge) Protection:
 - $\pm 15kV$ IEC 61000-4-2 Air Gap Discharge
 - $\pm 8kV$ IEC 61000-4-2 Contact Discharge
 - $\pm 15kV$ Human Body Model
 - $\pm 4kV$ Human Body Model on non-bus pins
- **+4.5V to +5.5V Operation** ($5V \pm 10\%$)
- **300 μA Idle Current, 1nA Shutdown Current**
- Enhanced Receiver Fail-Safe Protection for Open, Shorted, or Terminated but Idle Data Lines
- Hot-Swap Glitch Protection on DE and \overline{RE} Pins
- Driver Short Circuit Current Limit and Thermal Shutdown for Overload Protection
- 1/8th Unit Load Allows up to 256 Devices on Bus
- Operating Temperature Range:
 - Industrial $-40^{\circ}C$ to $85^{\circ}C$
 - Extended $-40^{\circ}C$ to $125^{\circ}C$
- Industry Standard 8 and 14 NSOIC Packages

TYPICAL APPLICATIONS

- Motor Control
- Security Systems
- Building and Process Automation
- Remote Utility Meter Reading
- Energy Monitoring and Control
- Long or Unterminated Transmission Lines
- Profibus DP Fieldbus Networks



X S E R I E S : E X C E L L E N C E & R E L I A B I L I T Y

ABSOLUTE MAXIMUM RATINGS

These are stress ratings only and functional operation of the device at these ratings or any other above those indicated in the operation sections to the specifications below is not implied. Exposure to absolute maximum rating conditions for extended periods of time may affect reliability and cause permanent damage to the device.

V_{CC}	-0.3V to +7.0V
Input Voltage at Control and Driver Input (\overline{RE} , DE, and DI)	-0.3V to +7.0V
Receiver Output Voltage (RO)	-0.3V to ($V_{CC} + 0.3V$)
Driver Output Voltage (A, B, Y and Z)	$\pm 18V$
Receiver Input Voltage (A and B, half or full duplex)	$\pm 18V$
Transient Voltage Pulse, through 100Ω Figure 6	$\pm 70V$
Driver Output Current	$\pm 250mA$
Storage Temperature Range	-65°C to +150°C
Lead Temperature (soldering, 10s)	+300°C
Package Power Dissipation 8-Pin SO $\Theta_{JA} = 128.4^{\circ}C/W$ 14-Pin SO $\Theta_{JA} = 86^{\circ}C/W$	Maximum Junction Temperature = +150°C

CAUTION:

ESD (Electrostatic Discharge) sensitive device. Permanent damage may occur on unconnected devices subject to high energy electrostatic fields. Unused devices must be stored in conductive foam or shunts. Personnel should be properly grounded prior to handling this device. The protective foam should be discharged to the destination socket before devices are removed.

**ORDERING INFORMATION**

PART NUMBER	DUPLEX	DATA RATE	PACKAGE	TEMPERATURE RANGE
XR3080XID-F	Full	250kbps	14-pin Narrow SOIC	-40°C to +85°C
XR3081XID-F	Full	250kbps	8-pin Narrow SOIC	-40°C to +85°C
XR3082XID-F	Half	250kbps	8-pin Narrow SOIC	-40°C to +85°C
XR3083XID-F	Full	1Mbps	14-pin Narrow SOIC	-40°C to +85°C
XR3084XID-F	Full	1Mbps	8-pin Narrow SOIC	-40°C to +85°C
XR3085XID-F	Half	1Mbps	8-pin Narrow SOIC	-40°C to +85°C
XR3086XID-F	Full	20Mbps	14-pin Narrow SOIC	-40°C to +85°C
XR3087XID-F	Full	20Mbps	8-pin Narrow SOIC	-40°C to +85°C
XR3088XID-F	Half	20Mbps	8-pin Narrow SOIC	-40°C to +85°C
XR3080XED-F	Full	250kbps	14-pin Narrow SOIC	-40°C to +125°C
XR3081XED-F	Full	250kbps	8-pin Narrow SOIC	-40°C to +125°C
XR3082XED-F	Half	250kbps	8-pin Narrow SOIC	-40°C to +125°C
XR3083XED-F	Full	1Mbps	14-pin Narrow SOIC	-40°C to +125°C
XR3084XED-F	Full	1Mbps	8-pin Narrow SOIC	-40°C to +125°C
XR3085XED-F	Half	1Mbps	8-pin Narrow SOIC	-40°C to +125°C
XR3086XED-F	Full	20Mbps	14-pin Narrow SOIC	-40°C to +125°C
XR3087XED-F	Full	20Mbps	8-pin Narrow SOIC	-40°C to +125°C
XR3088XED-F	Half	20Mbps	8-pin Narrow SOIC	-40°C to +125°C

NOTE: Tape and Reel part numbers are XR30xxXIDTR-F or XR30xxXEDTR-F, -F = Green / RoHS Compliant

ELECTRICAL CHARACTERISTICS

Unless otherwise noted: $V_{CC} = +5.0V \pm 10\%$, $T_A = T_{MIN}$ to T_{MAX} . Typical values are at $V_{CC} = 5.0V$, $T_A = +25^\circ C$.

SYMBOL	PARAMETERS	MIN.	TYP.	MAX.	UNITS	CONDITIONS
DRIVER DC CHARACTERISTICS						
V_{CC}	Supply Voltage Range	4.5		5.5	V	
V_{OD}	Differential Driver Output	3		V_{CC}	V	No Load
		3		V_{CC}	V	$R_L = 100\Omega$ (RS-422), Figure 3
		2.1		V_{CC}	V	$R_L = 54\Omega$ (RS-485), Figure 3
		2.1		V_{CC}	V	$-7V \leq V_{CM} \leq +12V$, Figure 4
ΔV_{OD}	Change in Magnitude of Differential Output Voltage			± 0.2	V	$R_L = 100\Omega$ (RS-422), or $R_L = 54\Omega$ (RS-485), Figure 3, Note 1
V_{CM}	Driver Common-Mode Output Voltage (steady state)		$V_{CC}/2$	3	V	
ΔV_{CM}	Change in Magnitude of Common-Mode Output Voltage			± 0.2	V	
V_{IH}	Logic Input Thresholds (DI, DE, \overline{RE})	2.0			V	Logic Input High
V_{IL}					V	Logic Input Low
V_{HYS}	Input Hysteresis (DI, DE, \overline{RE})		100		mV	
I_{IN}	Logic Input Current (DI, DE, \overline{RE})			± 1	μA	$0V \leq V_{IN} \leq V_{CC}$, After first transition, Note 2
	Logic Input Current (DE and \overline{RE})		100	± 200	μA	Until first transition, Note 2
$I_{A, B}$	Input Current (A and B)			125	μA	$V_{OUT} = +12V$, DE = 0V, $V_{CC} = 0V$ or 5.5V
		-100			μA	$V_{OUT} = -7V$, DE = 0V, $V_{CC} = 0V$ or 5.5V
I_{OL}	Output Leakage (Y and Z) Full Duplex (Note 2)			125	μA	$V_{OUT} = +12V$, DE = 0V, $V_{CC} = 0V$ or 5.5V
		-100			μA	$V_{OUT} = -7V$, DE = 0V, $V_{CC} = 0V$ or 5.5V
I_{OSD}	Driver Short-Circuit Output Current			± 250	mA	$-7V \leq V_{OUT} \leq +12V$, Figure 5
DRIVER THERMAL CHARACTERISTICS						
T_{TS}	Thermal Shutdown Temperature		175		$^\circ C$	Junction temperature, Note 4
T_{TSH}	Thermal Shutdown Hysteresis		15		$^\circ C$	Note 4



Unless otherwise noted: $V_{CC} = +5.0V \pm 10\%$, $T_A = T_{MIN}$ to T_{MAX} . Typical values are at $V_{CC} = 5.0V$, $T_A = +25^\circ C$.

SYMBOL	PARAMETERS	MIN.	TYP.	MAX.	UNITS	CONDITIONS
RECEIVER DC CHARACTERISTICS						
V_{TH}	Receiver Differential Threshold Voltage ($V_A - V_B$)	-200	-125	-50	mV	$-7V \leq V_{CM} \leq +12V$
ΔV_{OH}	Receiver Input Hysteresis		25		mV	$V_{CM} = 0V$
V_{OH}	Receiver Output High Voltage (RO)	$V_{CC}-1.5$			V	$I_{OUT} = -4mA$
V_{OL}	Receiver Output Low Voltage (RO)			0.4	V	$I_{OUT} = 4mA$
I_{OZR}	High-Z Receiver Output Current			± 1	μA	$0V \leq V_{OUT} \leq V_{CC}$
R_{IN}	Receiver Input Resistance	96			k Ω	$-7V \leq V_{CM} \leq +12V$
I_{OSC}	Receiver Output Short-Circuit Current			± 95	mA	$0V \leq V_{RO} \leq V_{CC}$
SUPPLY CURRENT						
I_{CC}	Supply Current		425	600	μA	No Load, $\overline{RE} = 0V$, $DE = V_{CC}$ $DI = 0V$
			330	600	μA	No Load, $\overline{RE} = V_{CC}$, $DE = V_{CC}$ $DI = 0V$
			300	600	μA	No Load, $\overline{RE} = 0V$, $DE = 0V$ Receiver A and B inputs open
I_{SHDN}	Supply Current in Shutdown Mode		0.001	1	μA	$\overline{RE} = V_{CC}$, $DE = 0V$, Temperature grade I
			0.001	3	μA	$\overline{RE} = V_{CC}$, $DE = 0V$ Temperature grade E
ESD PROTECTION						
	ESD Protection for A, B, Y, and Z		± 15		kV	Human Body Model
			± 15		kV	IEC 61000-4-2 Airgap
			± 8		kV	IEC 61000-4-2 Contact
	ESD Protection for all other pins		± 4		kV	Human Body Model

Unless otherwise noted: $V_{CC} = +5.0V \pm 10\%$, $T_A = T_{MIN}$ to T_{MAX} . Typical values are at $V_{CC} = 5.0V$, $T_A = +25^\circ C$.

SYMBOL	PARAMETERS	MIN.	TYP.	MAX.	UNITS	CONDITIONS
DRIVER AC CHARACTERISTICS		XR3080X, XR3081X and XR3082X (250kbps)				
t_{DPLH}	Driver Prop. Delay (Low to High)	350		1500	ns	$C_L = 50pF$, $R_L = 54\Omega$, Figure 7
t_{DPHL}	Driver Prop. Delay (High to Low)	350		1500	ns	
$ t_{DPLH} - t_{DPHL} $	Differential Driver Output Skew		20	200	ns	
t_{DR} , t_{DF}	Driver Differential Output Rise or Fall Time	400		1500	ns	
	Maximum Data Rate	250			kbps	$1/t_{UI}$, Duty Cycle 40 to 60%
t_{DZH}	Driver Enable to Output High		200	2500	ns	$C_L = 50pF$, $R_L = 500\Omega$, Figure 8
t_{DZL}	Driver Enable to Output Low		200	2500	ns	
t_{DHZ}	Driver Disable from Output High		6	100	ns	
t_{DLZ}	Driver Disable from Output Low		6	100	ns	
$t_{DZH(SHDN)}$	Driver Enable from Shutdown to Output High			5500	ns	$C_L = 50pF$, $R_L = 500\Omega$, Figure 8
$t_{DZL(SHDN)}$	Driver Enable from Shutdown to Output Low			5500	ns	
t_{SHDN}	Time to Shutdown	50	200	600	ns	Notes 3 and 4
RECEIVER AC CHARACTERISTICS		XR3080X, XR3081X and XR3082X (250kbps)				
t_{RPLH}	Receiver Prop. Delay (Low to High)			200	ns	$C_L = 15pF$, $V_{ID} = \pm 2V$, V_{ID} Rise and Fall times < 15ns Figure 9
t_{RPHL}	Receiver Prop. Delay (High to Low)			200	ns	
$ t_{RPLH} - t_{RPHL} $	Receiver Propagation Delay Skew			30	ns	
	Maximum Data Rate	250			kbps	$1/t_{UI}$, Duty Cycle 40 to 60%
t_{RZH}	Receiver Enable to Output High			50	ns	$C_L = 15pF$, $R_L = 1k\Omega$, Figure 10
t_{RZL}	Receiver Enable to Output Low			50	ns	
t_{RHZ}	Receiver Disable from Output High			50	ns	
t_{RLZ}	Receiver Disable from Output Low			50	ns	
$t_{RZH(SHDN)}$	Receiver Enable from Shutdown to Output High			3500	ns	$C_L = 15pF$, $R_L = 1k\Omega$, Figure 10
$t_{RZL(SHDN)}$	Receiver Enable from Shutdown to Output Low			3500	ns	
t_{SHDN}	Time to Shutdown	50	200	600	ns	Notes 3 and 4



Unless otherwise noted: $V_{CC} = +5.0V \pm 10\%$, $T_A = T_{MIN}$ to T_{MAX} . Typical values are at $V_{CC} = 5.0V$, $T_A = +25^\circ C$.

SYMBOL	PARAMETERS	MIN.	TYP.	MAX.	UNITS	CONDITIONS
DRIVER AC CHARACTERISTICS		XR3083X, XR3084X and XR3085X (1Mbps)				
t_{DPLH}	Driver Prop. Delay (Low to High)		150	500	ns	$C_L = 50pF$, $R_L = 54\Omega$, Figure 7
t_{DPHL}	Driver Prop. Delay (High to Low)		150	500	ns	
$ t_{DPLH} - t_{DPHL} $	Differential Driver Output Skew		5	50	ns	
t_{DR} , t_{DF}	Driver Differential Output Rise or Fall Time	100	200	300	ns	
	Maximum Data Rate	1			Mbps	$1/t_{UI}$, Duty Cycle 40 to 60%
t_{DZH}	Driver Enable to Output High		1000	2500	ns	$C_L = 50pF$, $R_L = 500\Omega$, Figure 8
t_{DZL}	Driver Enable to Output Low		1000	2500	ns	
t_{DHZ}	Driver Disable from Output High		60	100	ns	
t_{DLZ}	Driver Disable from Output Low		60	100	ns	
$t_{DZH(SHDN)}$	Driver Enable from Shutdown to Output High		2500	4500	ns	$C_L = 50pF$, $R_L = 500\Omega$, Figure 8
$t_{DZL(SHDN)}$	Driver Enable from Shutdown to Output Low		2500	4500	ns	
t_{SHDN}	Time to Shutdown	50	200	600	ns	Notes 3 and 4
RECEIVER AC CHARACTERISTICS		XR3083X, XR3084X and XR3085X (1Mbps)				
t_{RPLH}	Receiver Prop. Delay (Low to High)			200	ns	$C_L = 15pF$, $V_{ID} = \pm 2V$, V_{ID} Rise and Fall times < 15ns Figure 9
t_{RPHL}	Receiver Prop. Delay (High to Low)			200	ns	
$ t_{RPLH} - t_{RPHL} $	Receiver Propagation Delay Skew			30	ns	
	Maximum Data Rate	1			Mbps	$1/t_{UI}$, Duty Cycle 40 to 60%
t_{RZH}	Receiver Enable to Output High			50	ns	$C_L = 15pF$, $R_L = 1k\Omega$, Figure 10
t_{RZL}	Receiver Enable to Output Low			50	ns	
t_{RHZ}	Receiver Disable from Output High			50	ns	
t_{RLZ}	Receiver Disable from Output Low			50	ns	
$t_{RZH(SHDN)}$	Receiver Enable from Shutdown to Output High			3500	ns	$C_L = 15pF$, $R_L = 1k\Omega$, Figure 10
$t_{RZL(SHDN)}$	Receiver Enable from Shutdown to Output Low			3500	ns	
t_{SHDN}	Time to Shutdown	50	200	600	ns	Notes 3 and 4

Unless otherwise noted: $V_{CC} = +5.0V \pm 10\%$, $T_A = T_{MIN}$ to T_{MAX} . Typical values are at $V_{CC} = 5.0V$, $T_A = +25^\circ C$.

SYMBOL	PARAMETERS	MIN.	TYP.	MAX.	UNITS	CONDITIONS
DRIVER AC CHARACTERISTICS		XR3086X, XR3087X and XR3088X (20Mbps)				
t_{DPLH}	Driver Prop. Delay (Low to High)			20	ns	$C_L = 50pF$, $R_L = 54\Omega$, Figure 7
t_{DPHL}	Driver Prop. Delay (High to Low)			20	ns	
$ t_{DPLH} - t_{DPHL} $	Differential Driver Output Skew			5	ns	
t_{DR} , t_{DF}	Driver Differential Output Rise or Fall Time			15	ns	
	Maximum Data Rate	20			Mbps	$1/t_{UI}$, Duty Cycle 40 to 60%
t_{DZH}	Driver Enable to Output High			30	ns	$C_L = 50pF$, $R_L = 500\Omega$, Figure 8
t_{DZL}	Driver Enable to Output Low			30	ns	
t_{DHZ}	Driver Disable from Output High			30	ns	
t_{DLZ}	Driver Disable from Output Low			30	ns	
$t_{DZH(SHDN)}$	Driver Enable from Shutdown to Output High			250	ns	$C_L = 50pF$, $R_L = 500\Omega$, Figure 8
$t_{DZL(SHDN)}$	Driver Enable from Shutdown to Output Low			250	ns	
t_{SHDN}	Time to Shutdown	50	200	600	ns	Notes 3 and 4
RECEIVER AC CHARACTERISTICS		XR3086X, XR3087X and XR3088X (20Mbps)				
t_{RPLH}	Receiver Prop. Delay (Low to High)			40	ns	$C_L = 15pF$, $V_{ID} = \pm 2V$, V_{ID} Rise and Fall times < 15ns Figure 9
t_{RPHL}	Receiver Prop. Delay (High to Low)			40	ns	
$ t_{RPLH} - t_{RPHL} $	Receiver Propagation Delay Skew			5	ns	
	Maximum Data Rate	20			Mbps	$1/t_{UI}$, Duty Cycle 40 to 60%
t_{RZH}	Receiver Enable to Output High			30	ns	$C_L = 15pF$, $R_L = 1k\Omega$, Figure 10
t_{RZL}	Receiver Enable to Output Low			30	ns	
t_{RHZ}	Receiver Disable from Output High			30	ns	
t_{RLZ}	Receiver Disable from Output Low			30	ns	
$t_{RZH(SHDN)}$	Receiver Enable from Shutdown to Output High			2200	ns	$C_L = 15pF$, $R_L = 1k\Omega$, Figure 10
$t_{RZL(SHDN)}$	Receiver Enable from Shutdown to Output Low			2200	ns	
t_{SHDN}	Time to Shutdown	50	200	600	ns	Notes 3 and 4

**NOTE:**

1. *Change in Magnitude of Differential Output Voltage and Change in Magnitude of Common Mode Output Voltage are the changes in output voltage when DI input changes state.*
2. *The hot swap feature disables the DE and \overline{RE} inputs for the first 10 μ s after power is applied. Following this time period these inputs are weakly pulled to their disabled state (low for DE, high for \overline{RE}) until the first transition, after which they become high impedance inputs.*
3. *The transceivers are put into shutdown by bringing \overline{RE} High and DE Low simultaneously for at least 600ns. If the control inputs are in this state for less than 50ns, the device is guaranteed to not enter shutdown. If the enable inputs are held in this state for at least 600ns the device is assured to be in shutdown. Note that the receiver and driver enable times increase significantly when coming out of shutdown.*
4. *This spec is guaranteed by design and bench characterization.*

BLOCK DIAGRAMS

FIGURE 1. HALF DUPLEX (XR3082X, XR3085X, XR3088X)

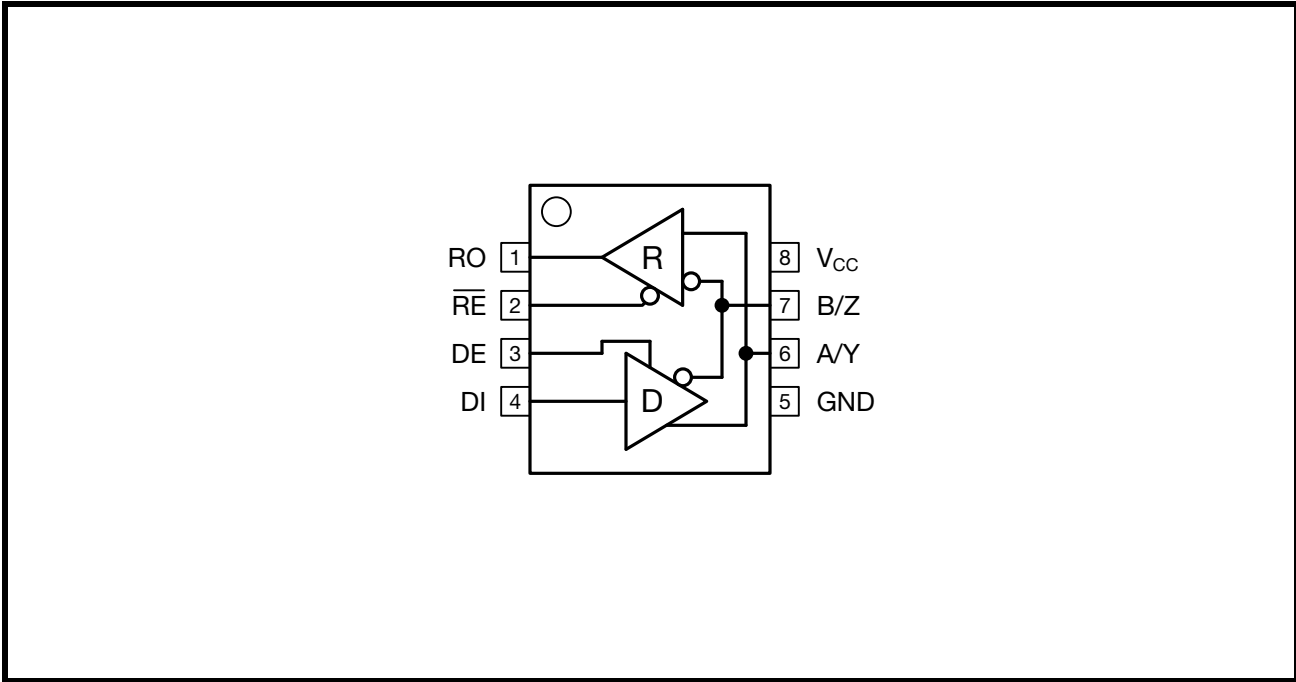
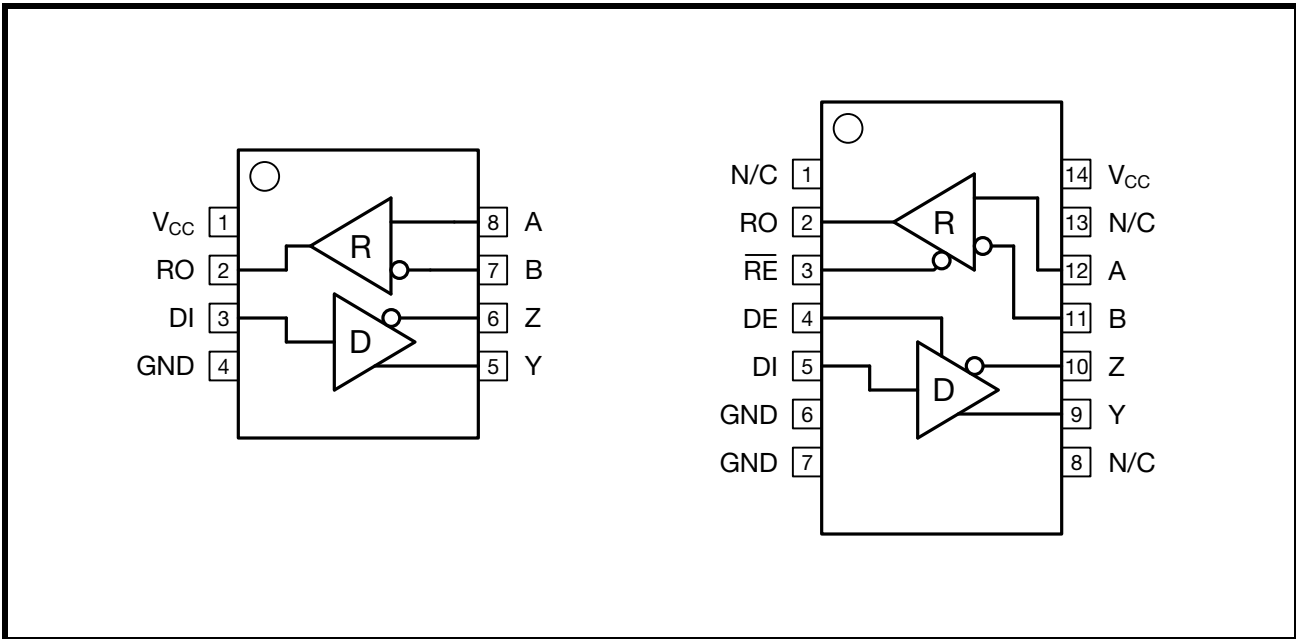

FIGURE 2. FULL DUPLEX (XR3080X, XR3081X, XR3083X, XR3084X, XR3086X, XR3087X)



TEST FIGURES

FIGURE 3. DIFFERENTIAL DRIVER OUTPUT VOLTAGE

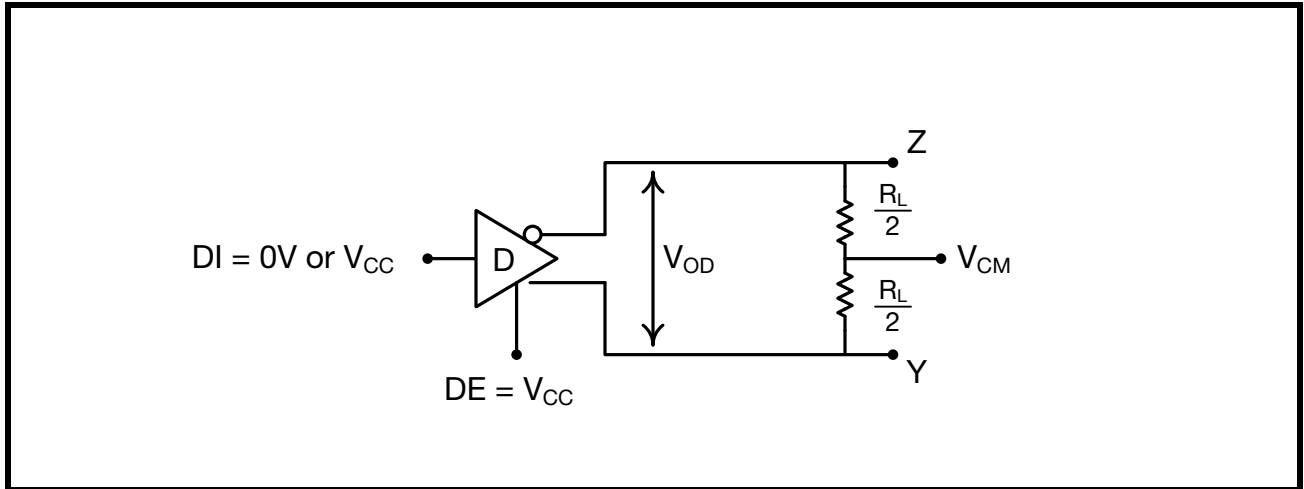

FIGURE 4. DIFFERENTIAL DRIVER OUTPUT VOLTAGE OVER COMMON MODE

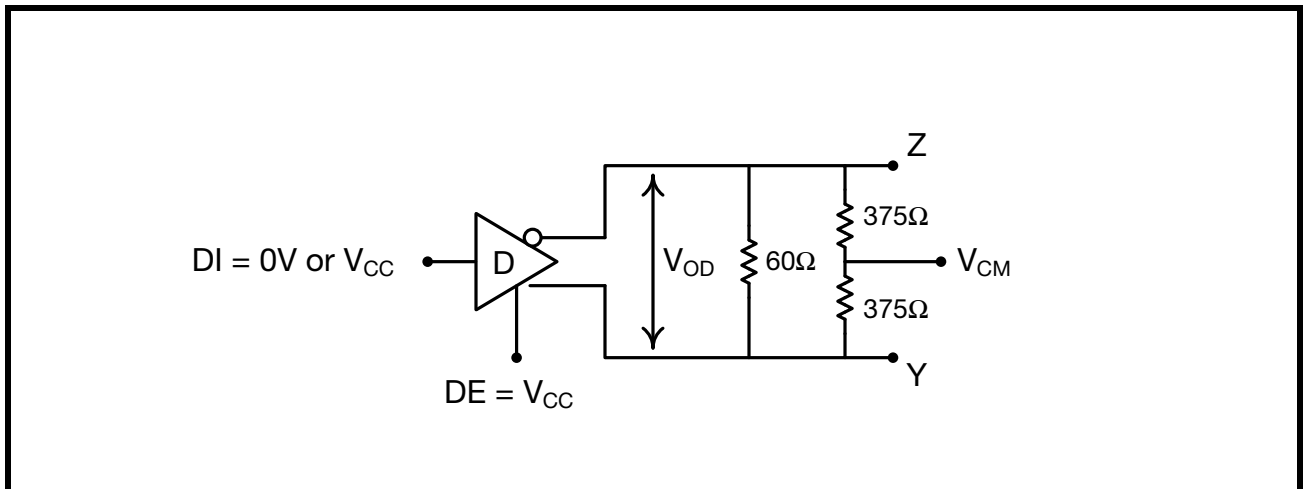

FIGURE 5. DRIVER OUTPUT SHORT CIRCUIT CURRENT

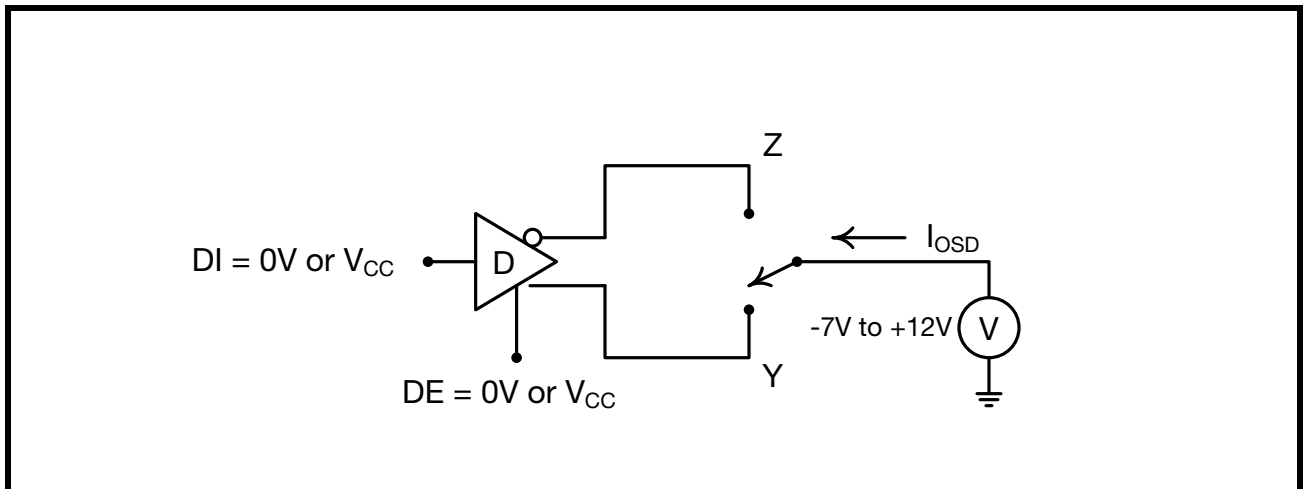

FIGURE 6. TRANSIENT OVER-VOLTAGE TEST CIRCUIT

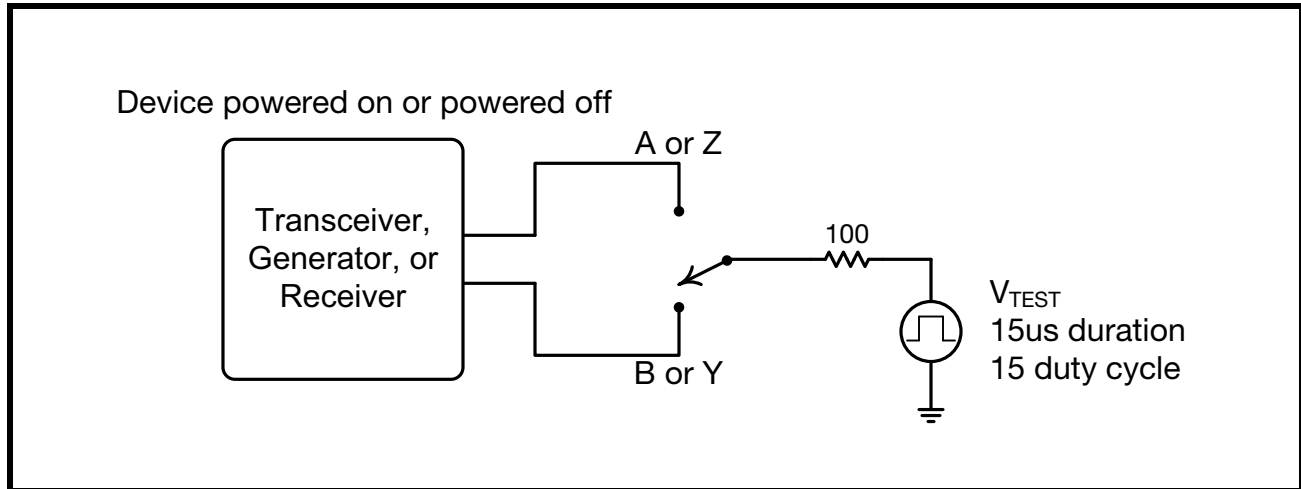

FIGURE 7. DRIVER PROPAGATION DELAY TEST CIRCUIT & TIMING DIAGRAM

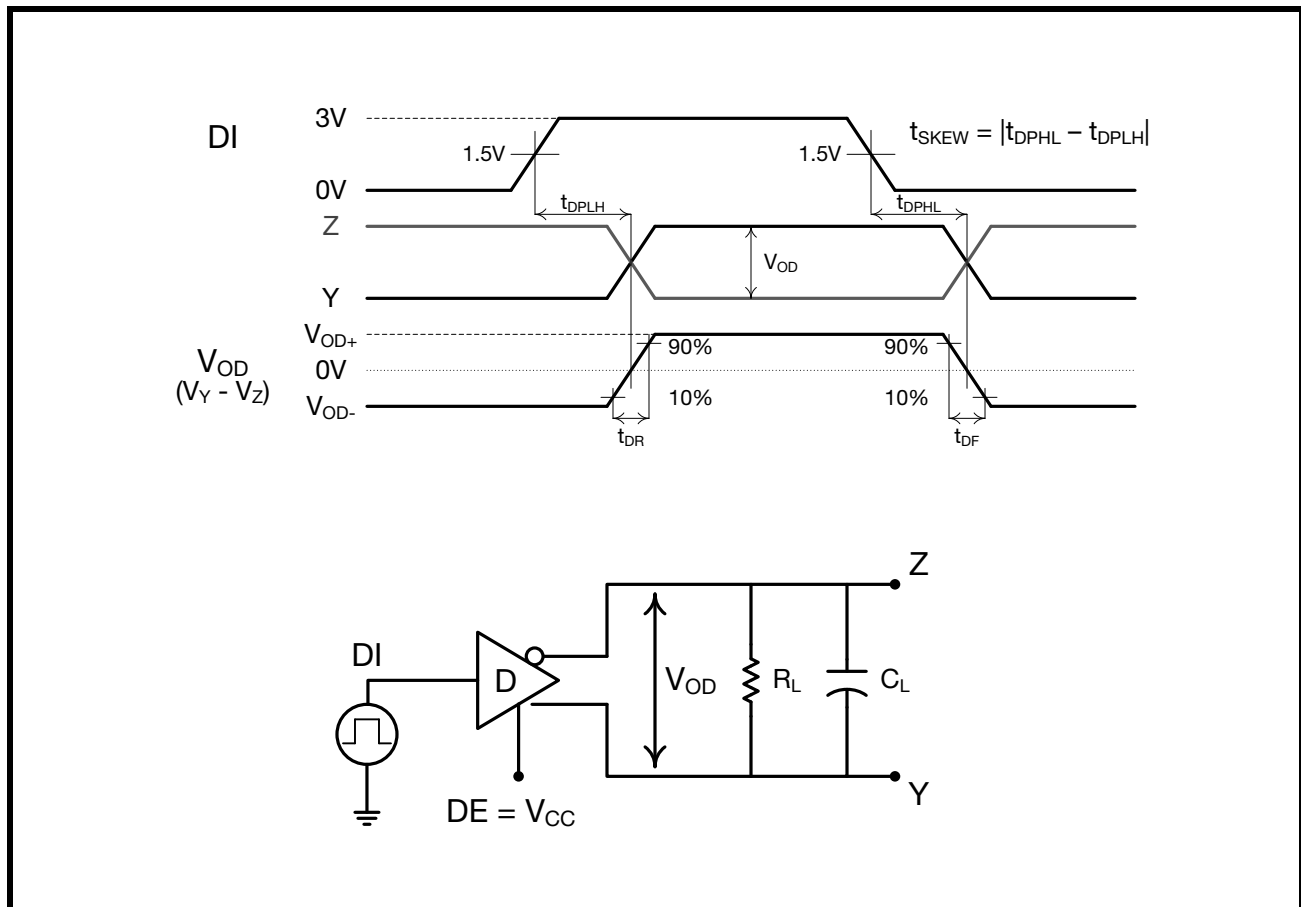

FIGURE 8. DRIVER ENABLE AND DISABLE TIMING TEST CIRCUITS & TIMING DIAGRAMS

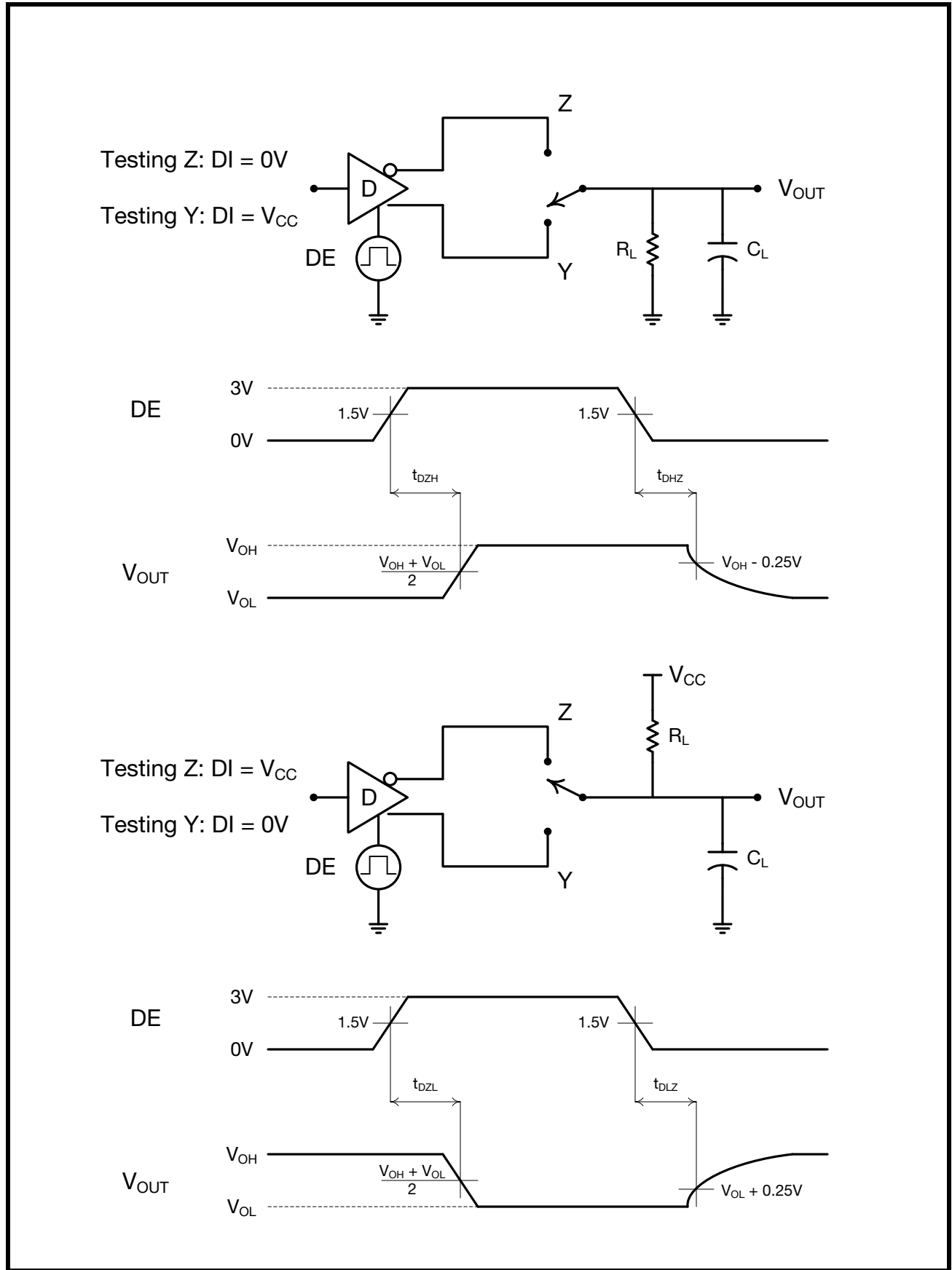

FIGURE 9. RECEIVER PROPAGATION DELAY TEST CIRCUIT & TIMING DIAGRAM

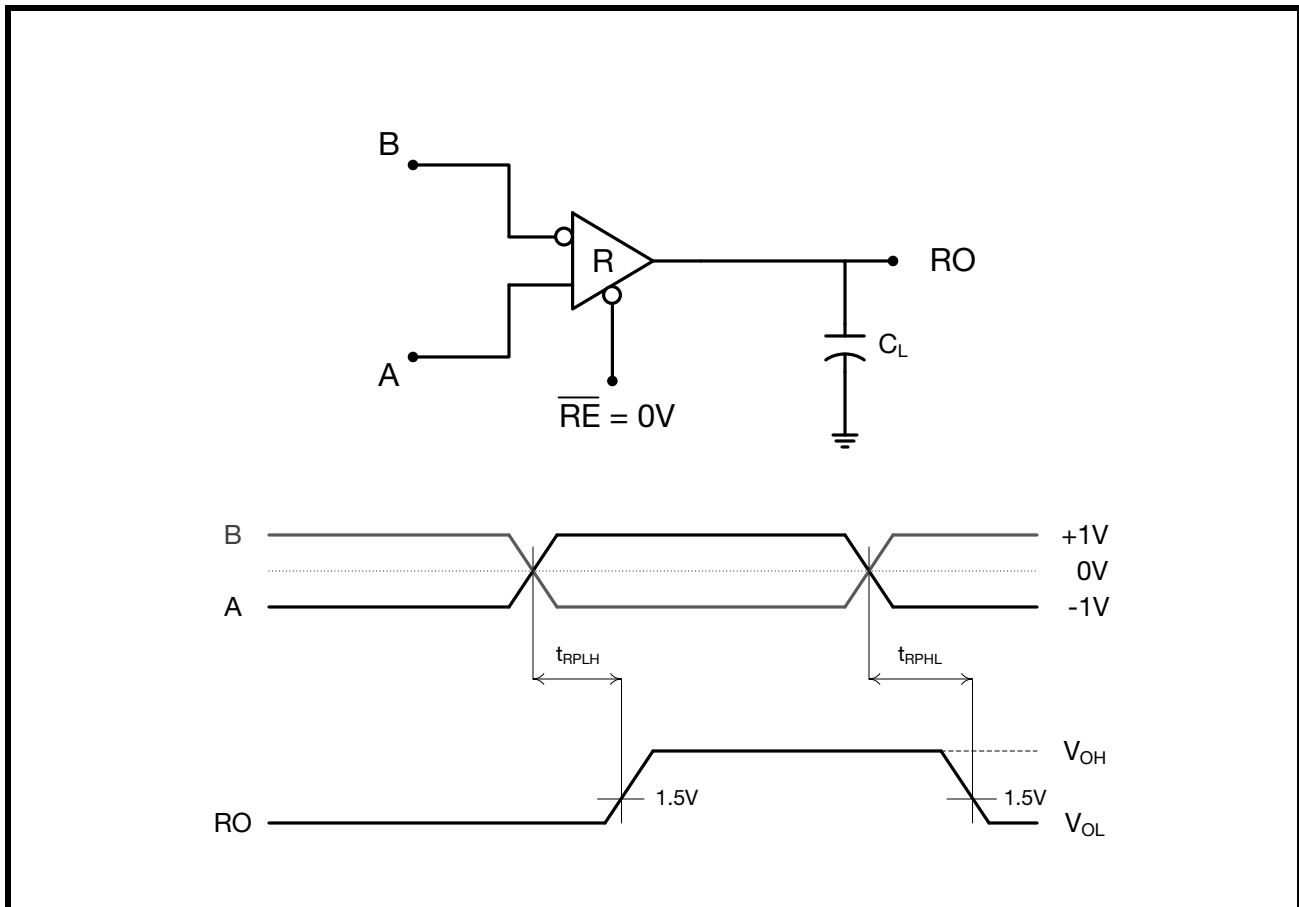
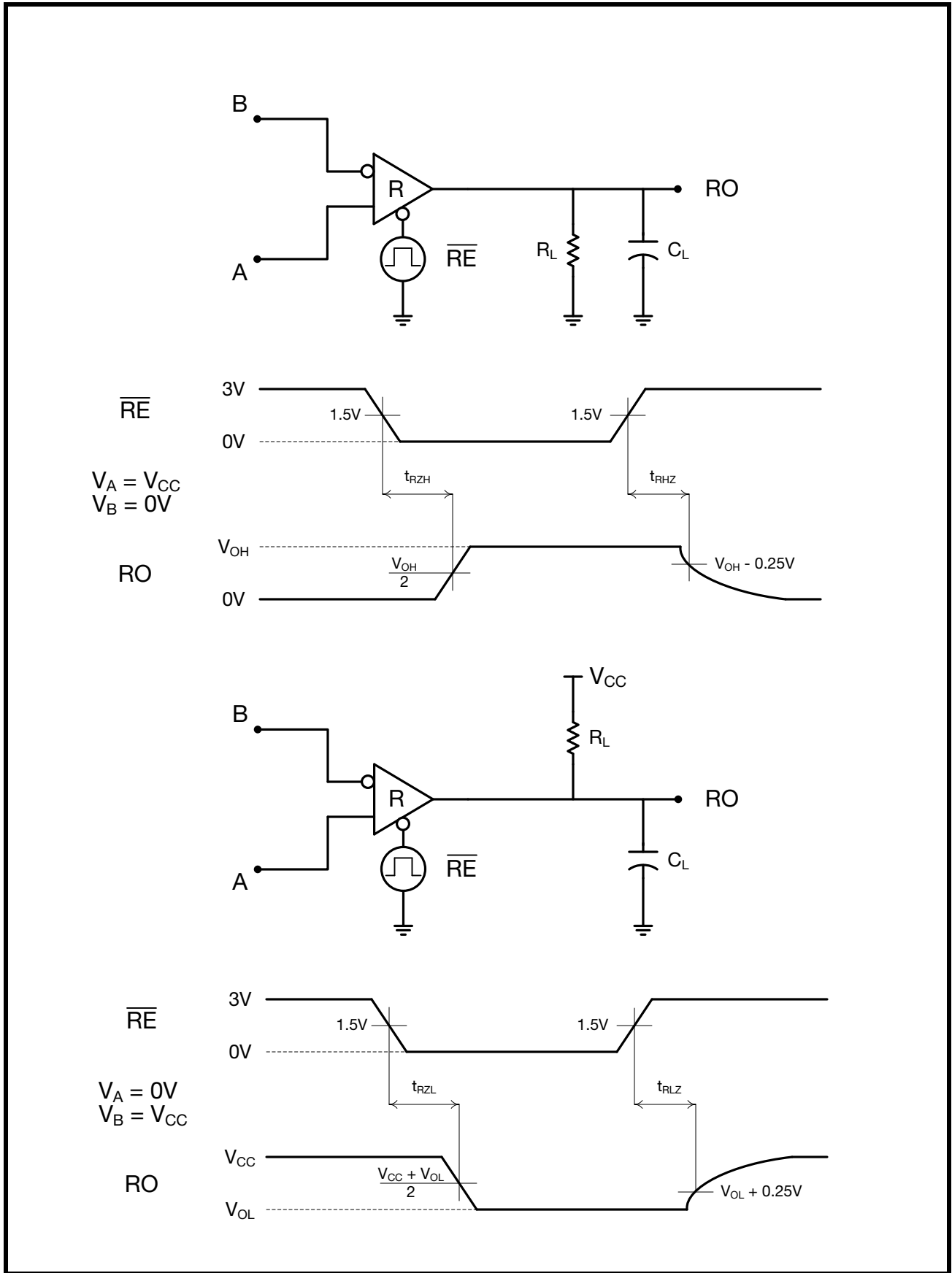

FIGURE 10. RECEIVER ENABLE AND DISABLE TEST CIRCUITS & TIMING DIAGRAMS



PIN DESCRIPTIONS

PIN NUMBER			PIN NAME	TYPE	DESCRIPTION
HALF DUPLEX	FULL DUPLEX				
XR3082X XR3085X XR3088X	XR3081X XR3084X XR3087X	XR3080X XR3083X XR3086X			
1	2	2	RO	Out	Receiver Output. When \overline{RE} is low and if $(A-B) \leq -50\text{mV}$, RO is high. If $(A-B) \geq -200\text{mV}$, RO is Low.
2	-	3	\overline{RE}	In	Receiver Output Enable (Hot Swap). When \overline{RE} is low, RO is enabled. When \overline{RE} is High, RO is high impedance. \overline{RE} should be high and DE should be low to enter shutdown mode.
3	-	4	DE	In	Driver Output Enable (Hot Swap). When DE is high, outputs are enabled. When DE is low, outputs are high impedance. DE should be low and \overline{RE} should be high to enter shutdown mode.
4	3	5	DI	In	Driver Input. With DE high, a low level on DI forces non-Inverting output low and inverting output high. Similarly, a high level on DI forces non-Inverting output high and inverting output low.
5	4	6, 7	GND	Pwr	Ground.
6	-	-	A	I/O	Non-Inverting Receiver Input and Non-Inverting Driver Output.
7	-	-	B	I/O	Inverting Receiver Input and Inverting Driver Output.
8	1	14	V_{CC}	Pwr	+5.0V Power Supply Input. Bypass to ground with 0.1 μF capacitor.
-	8	12	A	In	Non-Inverting Receiver Input.
-	7	11	B	In	Inverting Receiver Input.
-	5	9	Y	Out	Non-Inverting Driver Output.
-	6	10	Z	Out	Inverting Driver Output.
-	-	1, 8, 13	N/C	-	No Connect, not internally connected.



PRODUCT DESCRIPTION

The XR3080-88X RS-485/422 devices are part of Exar's X Series high performance serial interface product line. The analog bus pins can survive direct shorts up to $\pm 18V$, and are protected against ESD events up to $\pm 15kV$. The Profibus compliant differential output delivers 40% higher SNR than other RS-485/422 devices, affording additional noise margin or extended cable lengths.

ENHANCED FAILSAFE

Ordinary RS-485 differential receivers will be in an indeterminate state whenever the data bus is not being actively driven. The enhanced failsafe feature of the XR3080-88X family guarantees a logic-high receiver output when the receiver inputs are open, shorted, or when they are connected to a terminated transmission line with all drivers disabled. In a terminated bus with all transmitters disabled, the receivers' differential input voltage is pulled to 0V by the termination. The XR3080-88X family interprets 0V differential as a logic high with a minimum 50mV noise margin while maintaining compliance with the EIA/TIA-485 standard of $\pm 200mV$. Although the XR3080-88X family does not need failsafe biasing resistors, it can operate without issue if biasing is used.

RECEIVER INPUT FILTERING

XR3080-85X receivers incorporate internal filtering in addition to input hysteresis. This filtering enhances noise immunity by ignoring signals that do not meet a minimum pulse width of 30ns. Receiver propagation delay increases slightly due to this filtering. The high speed XR3086X, XR3087X and XR3088X devices do not have this input filtering.

HOT-SWAP CAPABILITY

When V_{CC} is first applied the XR3080-88X family holds the driver enable and receiver enable inactive for approximately 10 microseconds. During power ramp-up other system ICs may drive unpredictable values, or tristated lines may be influenced by stray capacitance. The hot-swap feature prevents the XR3080-88X family from driving any output signal until power has stabilized. After the initial 10 μs , the driver and receiver enable pins are weakly pulled to their disabled states (low for DE, high for \overline{RE}) until the first transition. After the first transition, the DE and \overline{RE} pins operate as high impedance inputs.

If circuit boards are inserted into an energized backplane (commonly called "live insertion" or "hot-swap") power may suddenly be applied to all circuits. Without the hot-swap capability, this situation could improperly enable the transceiver's driver or receiver, driving invalid data onto shared busses and possibly causing driver contention or device damage.

DRIVER OUTPUT PROTECTION

Two mechanisms prevent excessive output current and power dissipation caused by faults or by bus contention. First, a driver current limit on the output stage provides immediate protection against short circuits over the whole common-mode voltage range. Second, a thermal-shutdown circuit forces the driver outputs into a high-impedance state if junction temperature becomes excessive.

LINE LENGTH

The RS-485/RS-422 standard covers line lengths up to 4000ft. Maximum achievable line length is a function of signal attenuation and noise. Termination prevents signal reflections by eliminating the impedance mismatches on a transmission line. Line termination is generally used if rise and fall times are shorter than the round-trip signal propagation time. Higher output drivers may allow longer cables to be used.

±15kV ESD PROTECTION

ESD protection structures are incorporated on all pins to protect against electrostatic discharges encountered during handling and assembly. The driver outputs and receiver inputs of the XR3080-88X family have extra protection against static electricity. Exar uses state of the art structures to protect these pins against ESD of ±15kV without damage. The ESD structures withstand high ESD in all states: normal operation, shutdown and powered down. After an ESD event, the XR3080-88X keep operating without latch-up or damage.

ESD protection can be tested in various ways. The transmitter outputs and receiver inputs of the XR3080-88X are characterized for protection to the following limits:

- ±15kV using the Human Body Model
- ± 8kV using the Contact Discharge Model
- ±15kV Air-gap Discharge Model

ESD TEST CONDITIONS

ESD performance depends on a variety of conditions. Contact Exar for a reliability report that documents test setup, methodology and results.

IEC 61000-4-2

The IEC 61000-4-2 standard covers ESD testing and performance of finished equipment. However, it does not specifically refer to integrated circuits. The XR3080-88X family helps you design equipment to meet IEC 61000-4-2, without sacrificing board-space and cost for external ESD-protection components.

The major differences between tests done using the Human body model and IEC 61000-4-2 is a higher peak current in IEC 61000-4-2. Series resistance is lower in the IEC 61000-4-2 model. Hence, the ESD withstand voltage measured to IEC 61000-4-2 is generally lower than that of human body model.

The air-gap test involves approaching the device with a charged probe. The contact discharge method connects the probe to the device before the probe is energized.

256 TRANSCEIVERS ON THE BUS

The standard RS-485 receiver input impedance is 12k Ohms (1 unit load). A standard driver can drive up to 32 unit loads. The XR3080-88X family of transceivers have a 1/8th unit load receiver input impedance of 96kΩ, allowing up to 256 transceivers to be connected in parallel on a communication line. Any combination of these devices and other RS-485 transceivers up to a total of 32 unit loads may be connected to the line.

LOW POWER SHUTDOWN MODE

Low-power shutdown mode is initiated by bringing both \overline{RE} high and DE low simultaneously. While in shutdown devices draw less than 1μA of supply current. DE and \overline{RE} may be tied together and driven by a single control signal. Devices are guaranteed not to enter shutdown if \overline{RE} is high and DE is low for less than 50ns. If the inputs are in this state for at least 600ns, the parts will enter shutdown.

Enable times t_{ZH} and t_{ZL} apply when the part is not in low-power shutdown state. Enable times $t_{ZH(SHDN)}$ and $t_{ZL(SHDN)}$ apply when the parts are shutdown. The drivers and receivers take longer to become enabled from low-power shutdown $t_{ZH(SHDN)}$ and $t_{ZL(SHDN)}$ than from driver / receiver disable mode (t_{ZH} and t_{ZL}).



FUNCTION TABLES

TABLE 1: FULL DUPLEX 14 PIN - XR3080X, XR3083X AND XR3086X

TRANSMITTING				
Inputs			Outputs	
\overline{RE}	DE	DI	Y	Z
X	1	1	1	0
X	1	0	0	1
0	0	X	High-Z	
1	0	X	Shutdown	

TABLE 2: FULL DUPLEX 8 PIN - XR3081X, XR3084X AND XR3087X

TRANSMITTING		
Input	Outputs	
DI	Y	Z
1	1	0
0	0	1

TABLE 3: HALF DUPLEX 8 PIN - XR3082X, XR3085X AND XR3088X

TRANSMITTING				
Inputs			Outputs	
\overline{RE}	DE	DI	A	B
X	1	1	1	0
X	1	0	0	1
0	0	X	High-Z	
1	0	X	Shutdown	

TABLE 4: FULL DUPLEX 14 PIN - XR3080X, XR3083X AND XR3086X

RECEIVING			
Inputs			Ouptut
\overline{RE}	DE	$V_A - V_B$	RO
0	X	$\geq -50mV$	1
0	X	$\leq -200mV$	0
0	X	Open/Shorted	1
1	1	X	High-Z
1	0	X	Shutdown

TABLE 5: FULL DUPLEX 8 PIN - XR3081X, XR3084X AND XR3087X

RECEIVING	
Inputs	Output
$V_A - V_B$	RO
$\geq -50mV$	1
$\leq -200mV$	0
Open/Shorted	1

TABLE 6: HALF DUPLEX 8 PIN - XR3082X, XR3085X AND XR3088X

RECEIVING			
Inputs			Output
\overline{RE}	DE	$V_A - V_B$	RO
0	X	$\geq -50mV$	1
0	X	$\leq -200mV$	0
0	X	Open/Shorted	1
1	1	X	High-Z
1	0	X	Shutdown

Note: Receiver inputs $-200mV \leq V_A - V_B \leq -50mV$ are considered indeterminate.



PRODUCT SELECTOR GUIDE

TABLE 7: SELECTION GUIDE

PART NUMBER	DUPLEX	DATA RATE	SHUTDOWN	RECEIVER AND DRIVER ENABLE	TRANS ON BUS	FOOTPRINT
XR3080XID-F	Full	250kbps	Yes	Yes	256	SN75180
XR3080XED-F	Full		Yes	Yes	256	SN75180
XR3081XID-F	Full		No	No	256	SN75179
XR3081XED-F	Full		No	No	256	SN75179
XR3082XID-F	Half		Yes	Yes	256	SN75176
XR3082XIE-F	Half		Yes	Yes	256	SN75176
XR3083XID-F	Full	1Mbps	Yes	Yes	256	SN75180
XR3083XED-F	Full		Yes	Yes	256	SN75180
XR3084XID-F	Full		No	No	256	SN75179
XR3084XED-F	Full		No	No	256	SN75179
XR3085XID-F	Half		Yes	Yes	256	SN75176
XR3085XED-F	Half		Yes	Yes	256	SN75176
XR3086XID-F	Full	20Mbps	Yes	Yes	256	SN75180
XR3086XED-F	Full		Yes	Yes	256	SN75180
XR3087XID-F	Full		No	No	256	SN75179
XR3087XED-F	Full		No	No	256	SN75179
XR3088XID-F	Half		Yes	Yes	256	SN75176
XR3088XED-F	Half		Yes	Yes	256	SN75176

PACKAGE DRAWINGS

FIGURE 11. 8 NSOIC

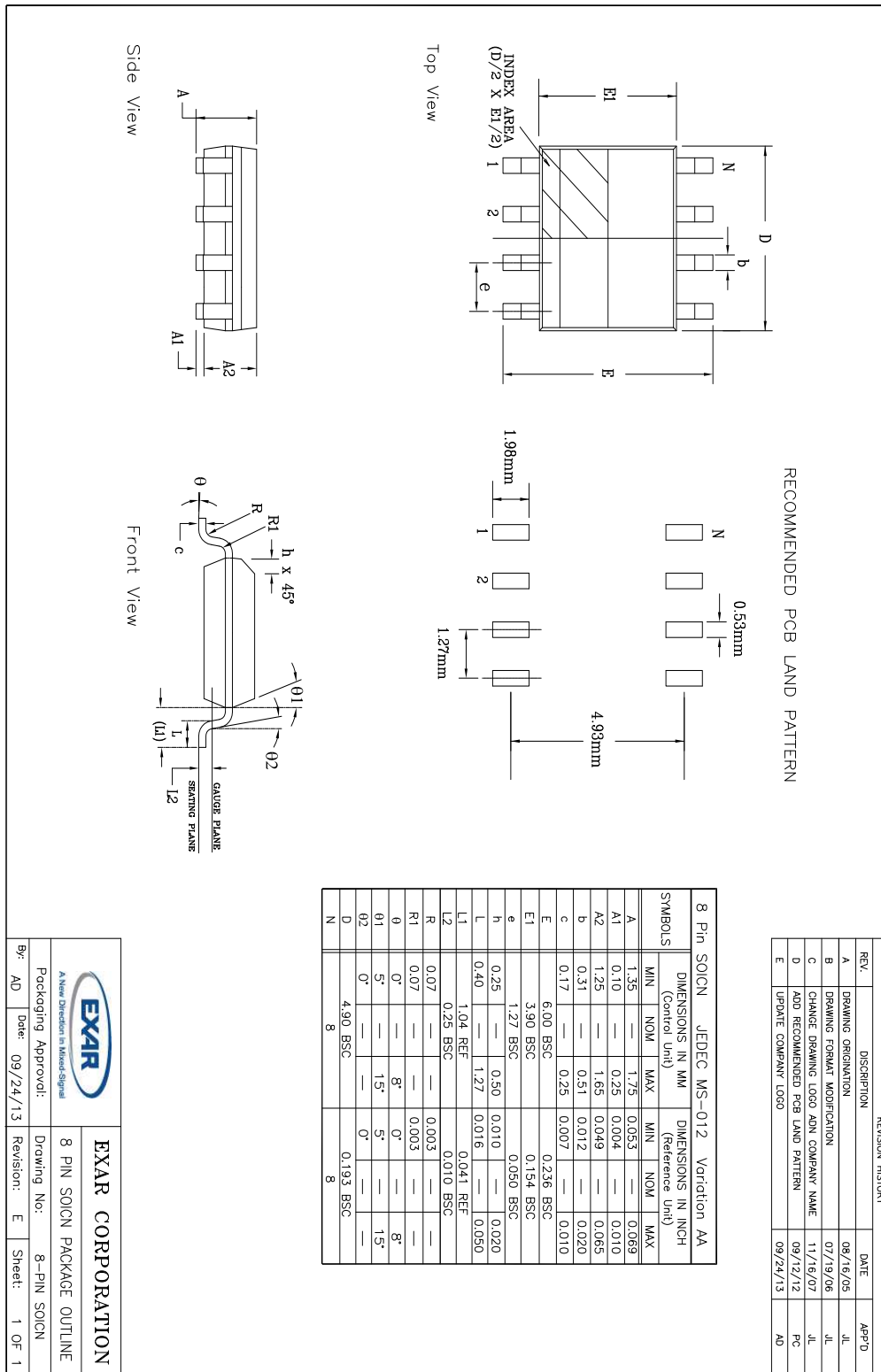

REV.	DESCRIPTION	DATE	APP'D
A	DRAWING ORIGINATOR	08/16/05	JL
B	DRAWING FORMAT MODIFICATION	07/19/06	JL
C	CHANGE DRAWING LOGO AND COMPANY NAME	11/16/07	JL
D	ADD RECOMMENDED PCB LAND PATTERN	08/12/12	FC
E	UPDATE COMPANY LOGO	09/24/13	AD

8 Pin SOICN		JEDEC MS-012	Variation AA		
DIMENSIONS IN MM (Control Unit)		DIMENSIONS IN INCH (Reference Unit)			
MIN	NOM	MAX	MIN	NOM	MAX
A New Dimension in Mixed-Signal					
Packaging Approvals:					
By: AD Date: 09/24/13 Revision: E Sheet: 1 OF 1					
EXAR CORPORATION					
8 PIN SOICN PACKAGE OUTLINE					
Drawing No: 8-PIN SOICN					

FIGURE 12. 14 NSOIC

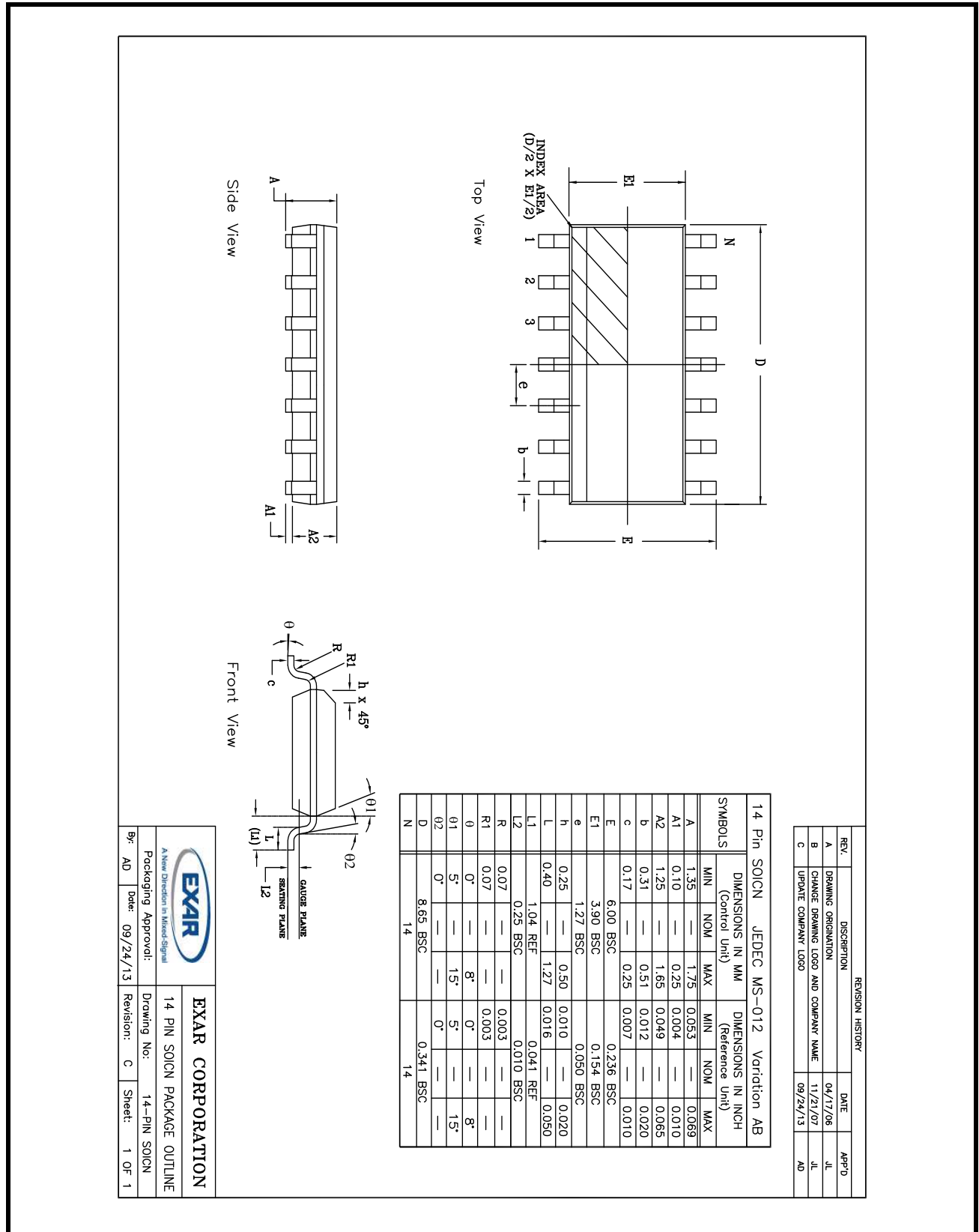

		EXAR CORPORATION	
A New Dimension in Mixed-Signal Packaging Approvals:		14 PIN SOICN PACKAGE OUTLINE	
By: AD	Date: 09/24/13	Drawing No: 14-PIN SOICN	Revision: C
		Sheet: 1 OF 1	

REVISION HISTORY			
REV.	DESCRIPTION	DATE	APP'D
A	DRAWING ORIGINATOR	04/17/06	JL
B	CHANGE DRAWING LOGO AND COMPANY NAME	11/21/07	JL
C	UPDATE COMPANY LOGO	09/24/13	AD

**REVISION HISTORY**

DATE	REVISION	DESCRIPTION
April 2013	1.0.0	Production Release
Sept 2013	1.0.1	Type formatting changes
July 2015	1.0.2	Added Figure 6 , add -extended temp range -40°C to 125°C part numbers, updated I _{SHDN} for industrial and extended temp ranges, updated ordering information table and table #7. ECN# 1530-01

NOTICE

EXAR Corporation reserves the right to make changes to the products contained in this publication in order to improve design, performance or reliability. EXAR Corporation assumes no responsibility for the use of any circuits described herein, conveys no license under any patent or other right, and makes no representation that the circuits are free of patent infringement. Charts and schedules contained here in are only for illustration purposes and may vary depending upon a user's specific application. While the information in this publication has been carefully checked; no responsibility, however, is assumed for inaccuracies.

EXAR Corporation does not recommend the use of any of its products in life support applications where the failure or malfunction of the product can reasonably be expected to cause failure of the life support system or to significantly affect its safety or effectiveness. Products are not authorized for use in such applications unless EXAR Corporation receives, in writing, assurances to its satisfaction that: (a) the risk of injury or damage has been minimized; (b) the user assumes all such risks; (c) potential liability of EXAR Corporation is adequately protected under the circumstances.

Copyright 2015 EXAR Corporation



Datasheet July 2015.

For technical support please email Exar's Serial Technical Support group at: serialtechsupport@exar.com.

Reproduction, in part or whole, without the prior written consent of EXAR Corporation is prohibited.

Looking for pricing, stock, or lifecycle information?

Click below to explore more details on WIN SOURCE:

-  [View XR3083XIDTR-F on WIN SOURCE](#)
-  [Exar Corporation](#) Information

Optimize Your Supply Chain with WIN SOURCE Solutions

-  Global Sourcing Solution
-  Obsolete Management
-  Cost Control Management
-  Shortage Management
-  Alternative Solution
-  Excess Inventory Management