



**THE DATASHEET OF  
PQ025EZ01ZZH**



# PQxxxEZ5MZxH Series

# PQxxxEZ01ZxH Series

Compact Surface Mount type  
Low Power-Loss Voltage Regulators

### ■ Features

1. Low voltage operation (Minimum operating voltage: 2.35V)  
2.5V input → available 1.5 to 1.8V
2. Low dissipation current  
Dissipation current at no load: MAX. 2mA  
Output OFF-state dissipation current: MAX. 5μA
3. Built-in overcurrent protection and overheat protection functions
4. RoHS directive compliant

### ■ Applications

1. Peripheral equipment of personal computers
2. Power supplies for various electronic equipment such as DVD player or STB

### ■ Model Line-up

| Output current (I <sub>o</sub> ) | Package type | Output voltage (V <sub>o</sub> ) |              |              |
|----------------------------------|--------------|----------------------------------|--------------|--------------|
|                                  |              | 1.5V                             | 1.8V         | 2.5V         |
| 0.5A                             | Taping       | PQ015EZ5MZPH                     | PQ018EZ5MZPH | PQ025EZ5MZPH |
|                                  | Sleeve       | PQ015EZ5MZZH                     | PQ018EZ5MZZH | PQ025EZ5MZZH |
| 1A                               | Taping       | PQ015EZ01ZPH                     | PQ018EZ01ZPH | PQ025EZ01ZPH |
|                                  | Sleeve       | PQ015EZ01ZZH                     | PQ018EZ01ZZH | PQ025EZ01ZZH |
|                                  |              | 3.0V                             | 3.3V         |              |
| 0.5A                             | Taping       | PQ030EZ5MZPH                     | PQ033EZ5MZPH |              |
|                                  | Sleeve       | PQ030EZ5MZZH                     | PQ033EZ5MZZH |              |
| 1A                               | Taping       | PQ030EZ01ZPH                     | PQ033EZ01ZPH |              |
|                                  | Sleeve       | PQ030EZ01ZZH                     | PQ033EZ01ZZH |              |

### ■ Outline Dimensions

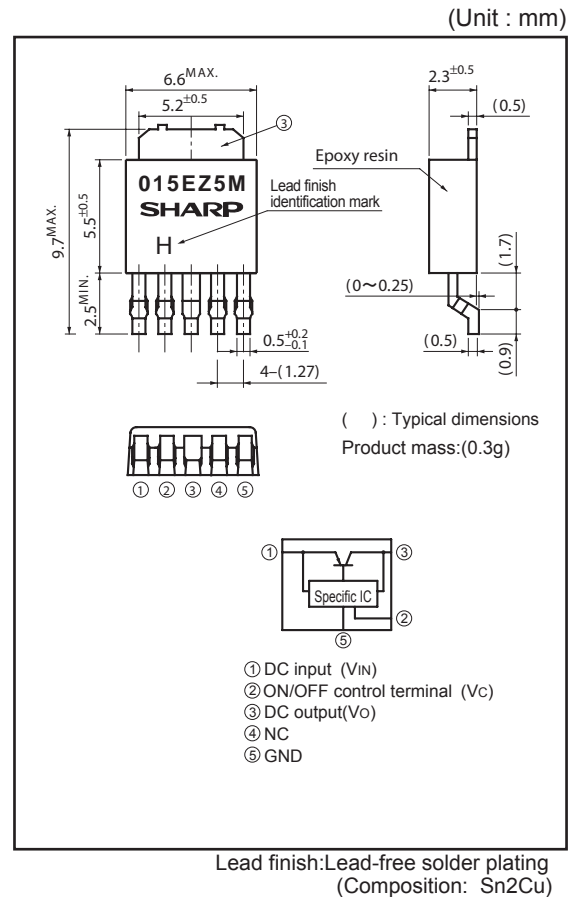

### ■ Absolute Maximum Ratings (T<sub>a</sub>=25°C)

| Parameter                          | Symbol              | Rating      | Unit |
|------------------------------------|---------------------|-------------|------|
| Input voltage                      | V <sub>IN</sub>     | 10          | V    |
| *1 ON/OFF control terminal voltage | V <sub>C</sub>      | 10          | V    |
| Output current                     | PQxxxEZ5MZxH Series | 0.5         | A    |
|                                    | PQxxxEZ01ZxH Series | 1           |      |
| *2 Power dissipation               | P <sub>D</sub>      | 8           | W    |
| *3 Junction temperature            | T <sub>j</sub>      | 150         | °C   |
| Operating temperature              | T <sub>opr</sub>    | -40 to +85  | °C   |
| Storage temperature                | T <sub>stg</sub>    | -40 to +150 | °C   |
| Soldering temperature              | T <sub>sol</sub>    | 260(10s)    | °C   |

\*1 All are open except GND and applicable terminals.  
\*2 P<sub>D</sub>: With infinite heat sink  
\*3 Overheat protection may operate at T<sub>j</sub>:125°C to 150°C

Notice The content of data sheet is subject to change without prior notice.

In the absence of confirmation by device specification sheets, SHARP takes no responsibility for any defects that may occur in equipment using any SHARP devices shown in catalogs, data books, etc. Contact SHARP in order to obtain the latest device specification sheets before using any SHARP device.

### Electrical Characteristics

(Unless otherwise specified, condition shall be  $V_{IN}=V_O(TYP.)+1V$ ,  $I_o=0.3A$ ,  $V_C=2.7V$ ,  $T_a=25^\circ C$  (PQxxxEZ5MZxH))  
 (Unless otherwise specified, condition shall be  $V_{IN}=V_O(TYP.)+1V$ ,  $I_o=0.5A$ ,  $V_C=2.7V$ ,  $T_a=25^\circ C$  (PQxxxEZ01ZxH))

| Parameter                                 |              | Symbol       | Conditions  | MIN.                 | TYP.       | MAX. | Unit          |
|---|--------------|--------------|---|----------------------|------------|------|---------------|
| Input voltage                             |              | $V_{IN}$     | —   | Refer to below table |            |      | V             |
| Output voltage                            |              | $V_O$        | —   | Refer to below table |            |      | V             |
| Load regulation                           | PQxxxEZ5MZxH | $R_{regL}$   | $I_o=5mA$ to 0.5A                                   | —                    | 0.2        | 2.0  | %             |
|   | PQxxxEZ01ZxH |              | $I_o=5mA$ to 1A                                     |                      |            |      |               |
| Line regulation                           |              | $R_{regI}$   | $V_{IN}=V_O(TYP.)+1V$ to $V_O(TYP.)+6V$ , $I_o=5mA$ | —                    | 0.1        | 1.0  | %             |
| Temperature coefficient of output voltage |              | $T_C V_O$    | $T_j=0$ to $125^\circ C$ , $I_o=5mA$                | —                    | $\pm 0.01$ | —    | %/ $^\circ C$ |
| Ripple Rejection                          |              | RR           | Refer to Fig.2                                      | 45                   | 60         | —    | dB            |
| *4 Dropout voltage                        | PQxxxEZ5MZxH | $V_{I-O}$    | *5 $I_o=0.3A$                                       | —                    | 0.2        | 0.5  | V             |
|   | PQxxxEZ01ZxH |              | *5 $I_o=0.5A$                                       |                      |            |      |               |
| *6 ON-state voltage for control           |              | $V_{C(ON)}$  | —   | 2.0                  | —          | —    | V             |
| ON-state current for control              |              | $I_{C(ON)}$  | —   | —                    | —          | 200  | $\mu A$       |
| OFF-state voltage for control             |              | $V_{C(OFF)}$ | —   | —                    | —          | 0.8  | V             |
| OFF-state current for control             |              | $I_{C(OFF)}$ | $V_C=0.4V$  | —                    | —          | 2    | $\mu A$       |
| Quiescent current                         |              | $I_q$        | $I_o=0A$  | —                    | 1          | 2    | mA            |
| Output OFF-state dissipation current      |              | $I_{qs}$     | $I_o=0A$ , $V_C=0.4V$                               | —                    | —          | 5    | $\mu A$       |

\*4 Applied PQ030EZ5MZxH, PQ033EZ5MZxH

\*5 Input voltage shall be the value when output voltage is 95% in comparison with the initial value.

\*6 In case of opening control terminal ②, output voltage turns off.

### Input voltage range

(Unless otherwise specified, condition shall be  $I_o=0.3A$ ,  $V_C=2.7V$ ,  $T_a=25^\circ C$  (PQxxxEZ5MZxH))  
 (Unless otherwise specified, condition shall be  $I_o=0.5A$ ,  $V_C=2.7V$ ,  $T_a=25^\circ C$  (PQxxxEZ01ZxH))

| Model No.                   | Symbol   | Conditions | MIN. | TYP. | MAX. | Unit |
|-----------------------------|----------|------------|------|------|------|------|
| PQ015EZ5MZxH / PQ015EZ01ZxH | $V_{IN}$ | —          | 2.35 | —    | 10   | V    |
| PQ018EZ5MZxH / PQ018EZ01ZxH | $V_{IN}$ | —          | 2.35 | —    | 10   | V    |
| PQ025EZ5MZxH / PQ025EZ01ZxH | $V_{IN}$ | —          | 3.0  | —    | 10   | V    |
| PQ030EZ5MZxH / PQ030EZ01ZxH | $V_{IN}$ | —          | 3.5  | —    | 10   | V    |
| PQ033EZ5MZxH / PQ033EZ01ZxH | $V_{IN}$ | —          | 3.8  | —    | 10   | V    |

### Output voltage

(Unless otherwise specified, condition shall be  $V_{IN}=V_O(TYP.)+1V$ ,  $I_o=0.3A$ ,  $V_C=2.7V$ ,  $T_a=25^\circ C$  (PQxxxEZ5MZxH))  
 (Unless otherwise specified, condition shall be  $V_{IN}=V_O(TYP.)+1V$ ,  $I_o=0.5A$ ,  $V_C=2.7V$ ,  $T_a=25^\circ C$  (PQxxxEZ01ZxH))

| Model No.                   | Symbol | Conditions | MIN.  | TYP. | MAX.  | Unit |
|-----------------------------|--------|------------|-------|------|-------|------|
| PQ015EZ5MZxH / PQ015EZ01ZxH | $V_O$  | —          | 1.45  | 1.5  | 1.55  | V    |
| PQ018EZ5MZxH / PQ018EZ01ZxH | $V_O$  | —          | 1.75  | 1.8  | 1.85  | V    |
| PQ025EZ5MZxH / PQ025EZ01ZxH | $V_O$  | —          | 2.438 | 2.5  | 2.562 | V    |
| PQ030EZ5MZxH / PQ030EZ01ZxH | $V_O$  | —          | 2.925 | 3    | 3.075 | V    |
| PQ033EZ5MZxH / PQ033EZ01ZxH | $V_O$  | —          | 3.218 | 3.3  | 3.382 | V    |

Fig.1 Test Circuit

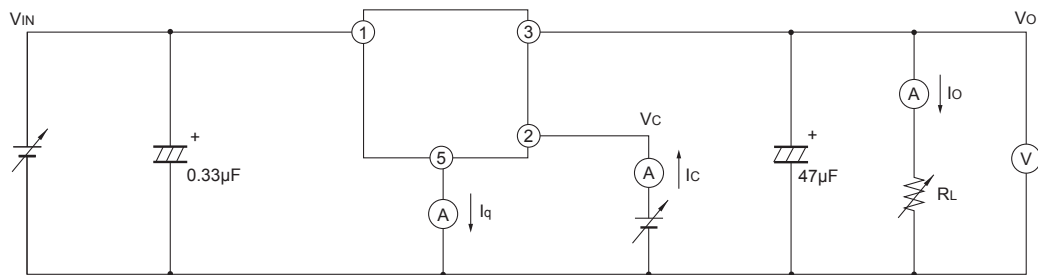
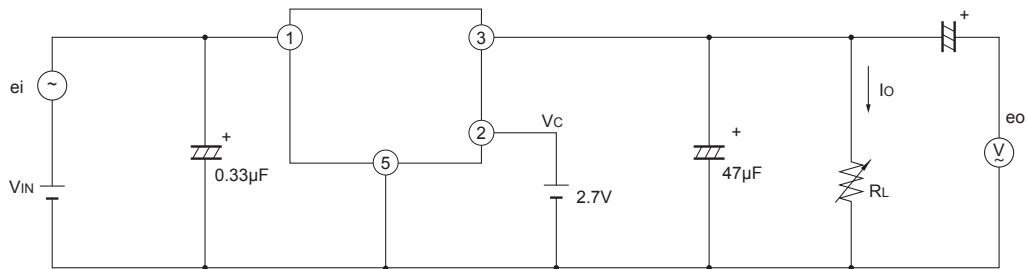
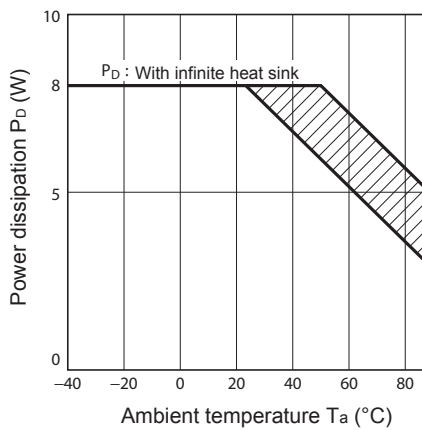

Fig.2 Test Circuit for Ripple Rejection



$f=120\text{Hz}(\text{sine wave})$   
 $e_i(\text{rms})=0.5\text{V}$   
 $V_{IN}=V_O(\text{TYP})+0.5\text{V}$   
 $I_O=0.3\text{A}$   
 $RR=20\log(e_i(\text{rms})/e_o(\text{rms}))$

Fig.3 Power Dissipation vs. Ambient Temperature



Note) Oblique line portion: Overheat protection may operate in this area.

Fig.4 Overcurrent Protection Characteristics (PQ015EZ5MZxH)

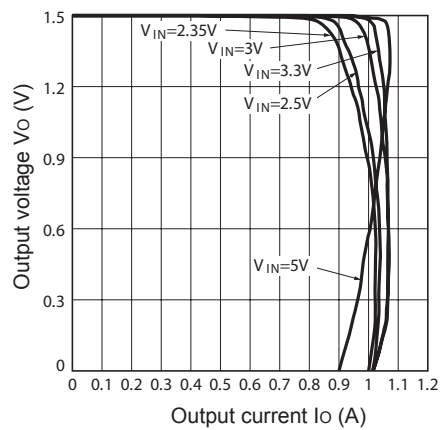

**Fig.5 Overcurrent Protection Characteristics (PQ018EZ5MZxH)**

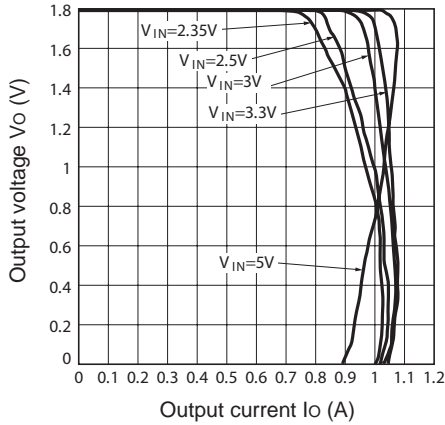

**Fig.6 Overcurrent Protection Characteristics (PQ025EZ5MZxH)**

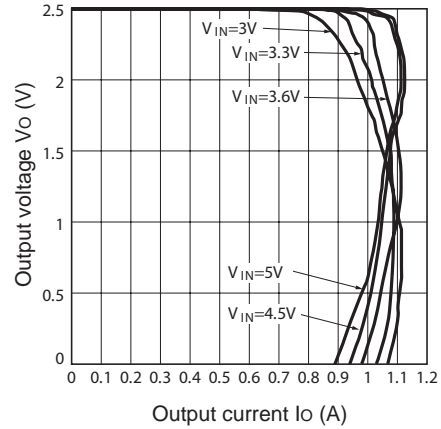

**Fig.7 Overcurrent Protection Characteristics (PQ030EZ5MZxH)**

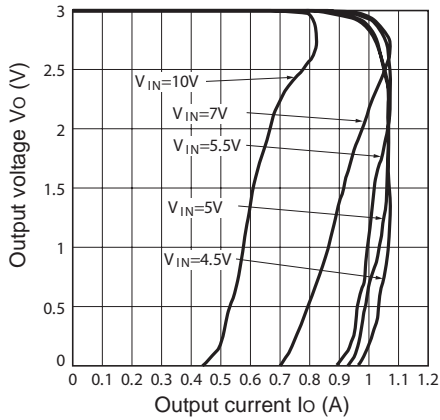

**Fig.8 Overcurrent Protection Characteristics (PQ033EZ5MZxH)**

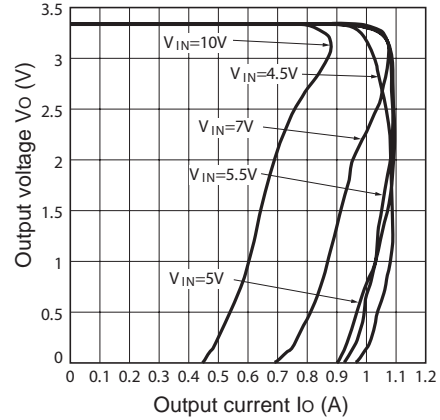

**Fig.9 Overcurrent Protection Characteristics (PQ015EZ01ZxH)**

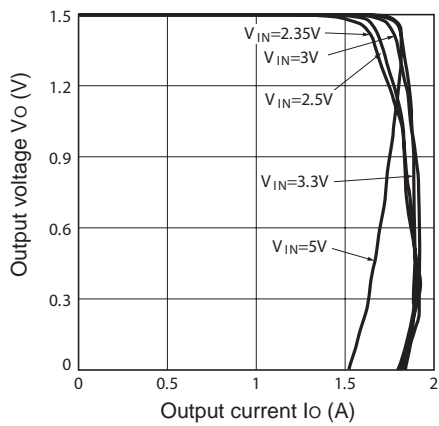

**Fig.10 Overcurrent Protection Characteristics (PQ018EZ01ZxH)**

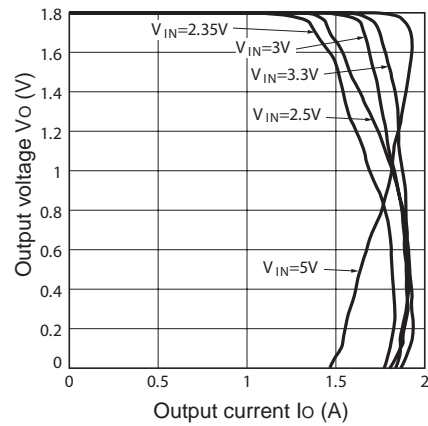

Fig.11 Overcurrent Protection Characteristics (PQ025EZ01ZxH)

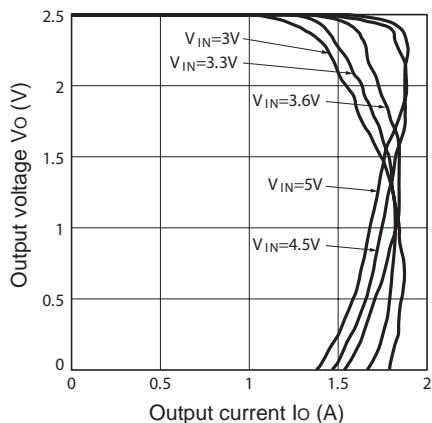

Fig.12 Overcurrent Protection Characteristics (PQ030EZ01ZxH)

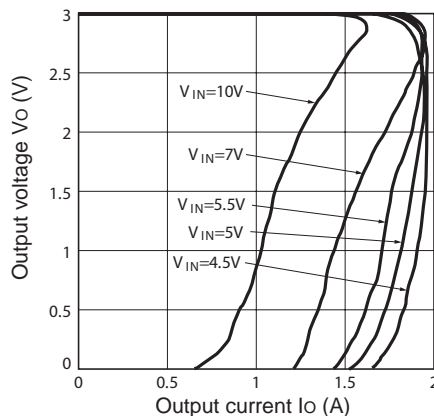

Fig.13 Overcurrent Protection Characteristics (PQ033EZ01ZxH)

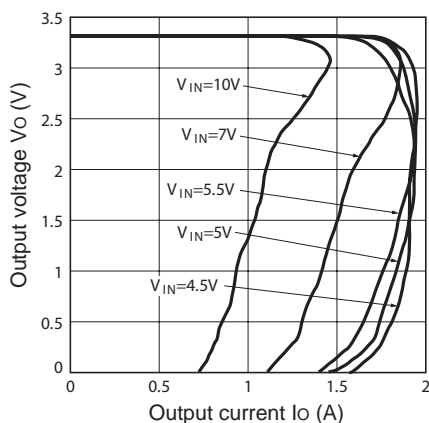

Fig.14 Output Voltage vs. Ambient Temperature (PQ015EZ5MZxH / PQ015EZ01ZxH)

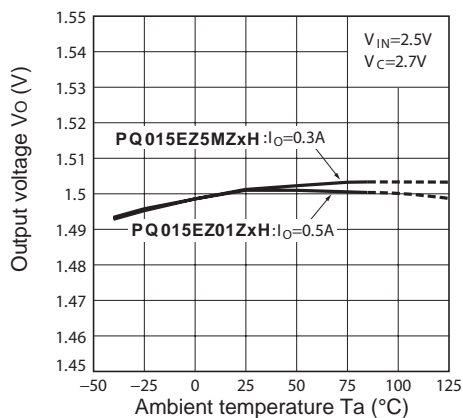

Fig.15 Output Voltage vs. Ambient Temperature (PQ018EZ5MZxH / PQ018EZ01ZxH)

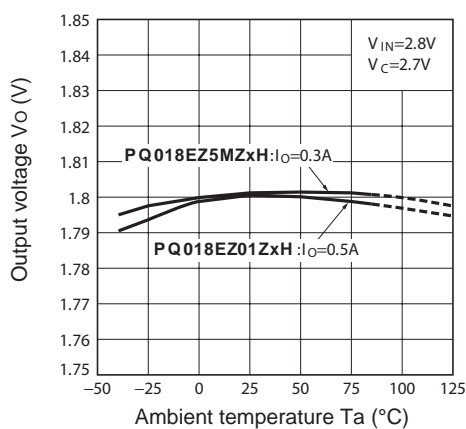

Fig.16 Output Voltage vs. Ambient Temperature (PQ025EZ5MZxH / PQ025EZ01ZxH)

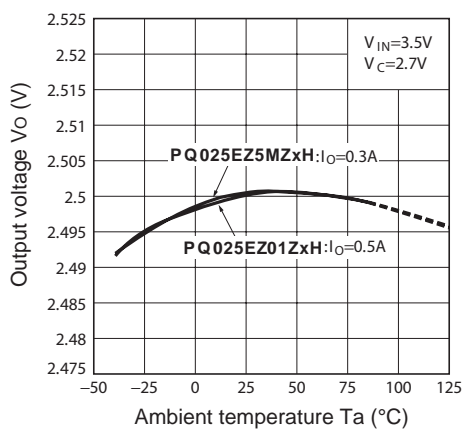

Fig.17 Output Voltage vs. Ambient Temperature (PQ030EZ5MZxH / PQ030EZ01ZxH)

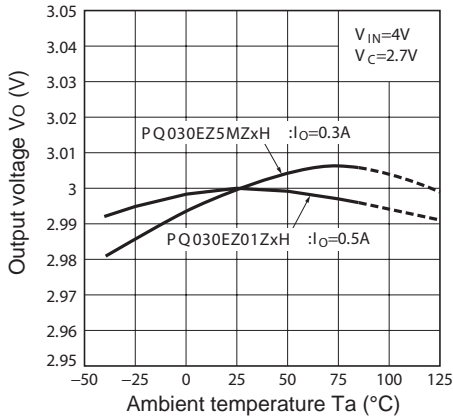

Fig.18 Output Voltage vs. Ambient Temperature (PQ033EZ5MZxH / PQ033EZ01ZxH)

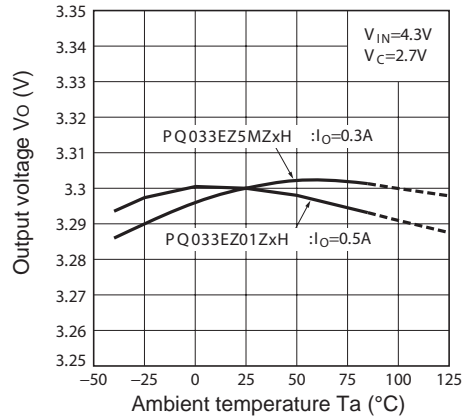

Fig.19 Output Voltage vs. Input Voltage (PQ015EZ5MZxH)

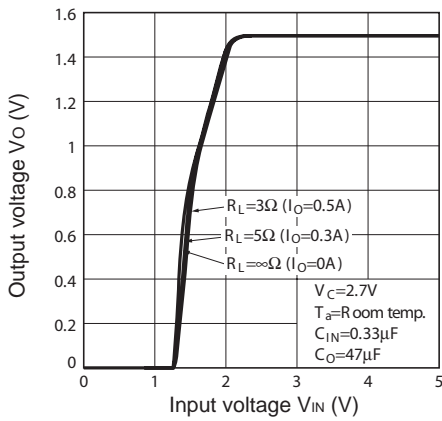

Fig.20 Output Voltage vs. Input Voltage (PQ018EZ5MZxH)

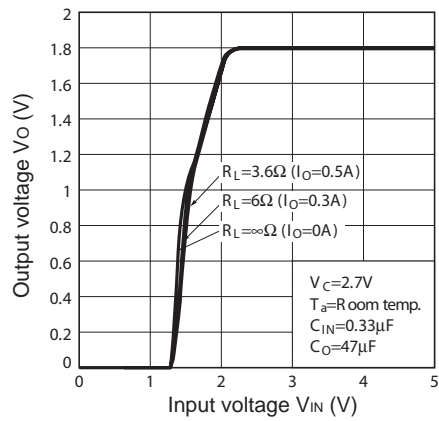

Fig.21 Output Voltage vs. Input Voltage (PQ025EZ5MZxH)

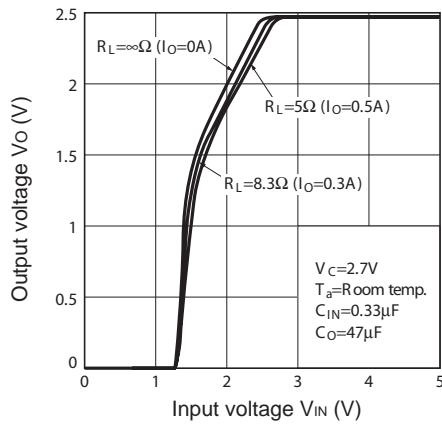
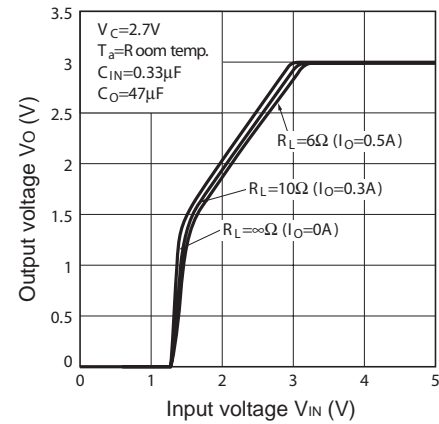
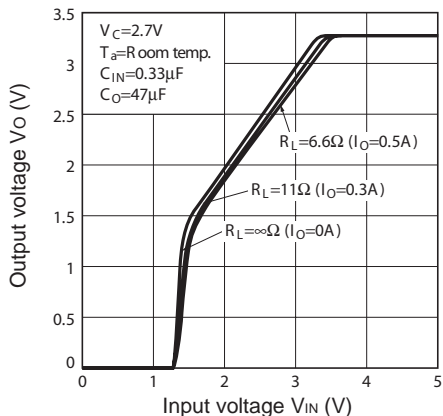

Fig.22 Output Voltage vs. Input Voltage (PQ030EZ5MZxH)



**Fig.23 Output Voltage vs. Input Voltage (PQ033EZ5MZxH)**



**Fig.24 Output Voltage vs. Input Voltage (PQ015EZ01ZxH)**

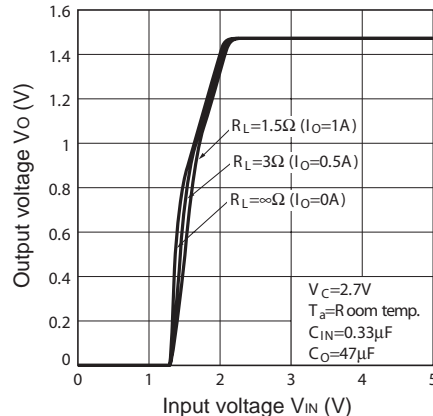

**Fig.25 Output Voltage vs. Input Voltage (PQ018EZ01ZxH)**

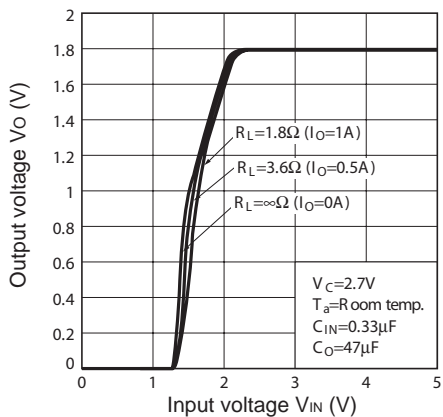

**Fig.26 Output Voltage vs. Input Voltage (PQ025EZ01ZxH)**

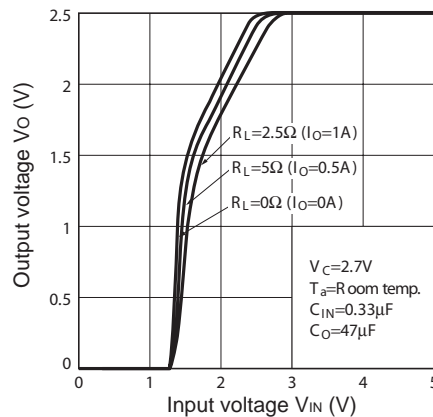

**Fig.27 Output Voltage vs. Input Voltage (PQ030EZ01ZxH)**

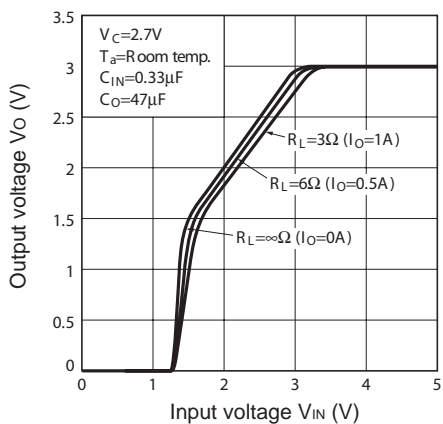

**Fig.28 Output Voltage vs. Input Voltage (PQ033EZ01ZxH)**

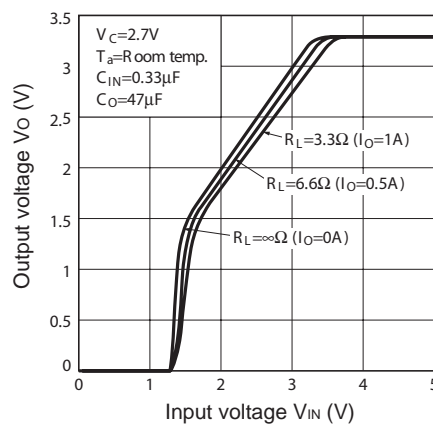

Fig.29 Circuit Operating Current vs. Input Voltage (PQ015EZ5MZxH)

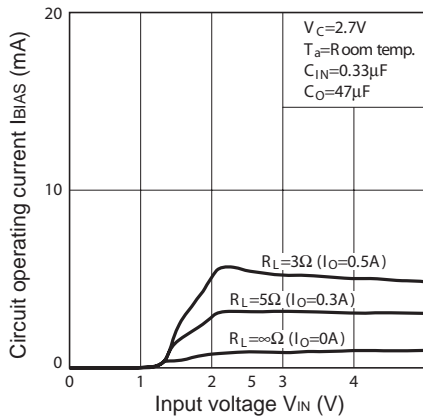

Fig.30 Circuit Operating Current vs. Input Voltage (PQ018EZ5MZxH)

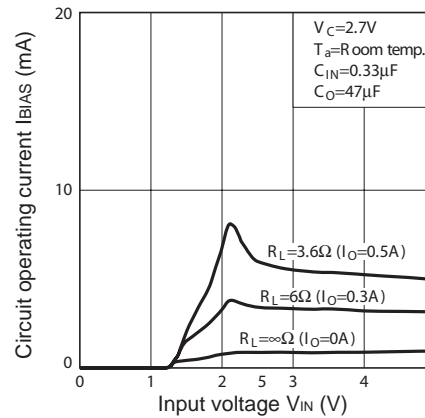

Fig.31 Circuit Operating Current vs. Input Voltage (PQ025EZ5MZxH)

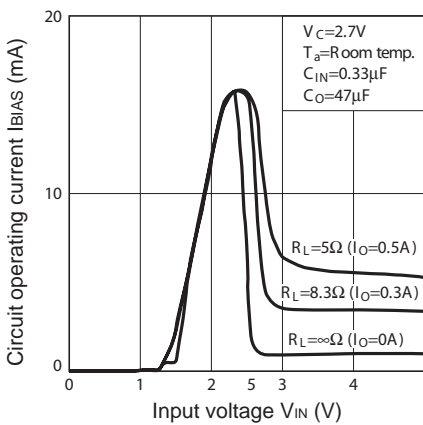

Fig.32 Circuit Operating Current vs. Input Voltage (PQ030EZ5MZxH)

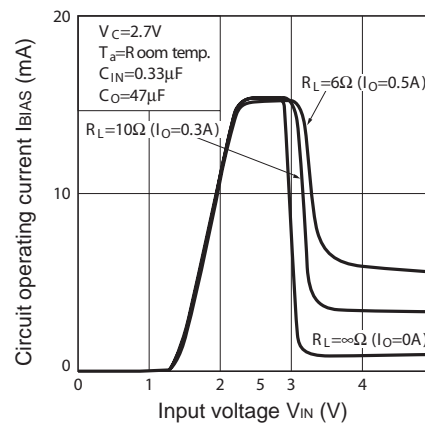

Fig.33 Circuit Operating Current vs. Input Voltage (PQ033EZ5MZxH)

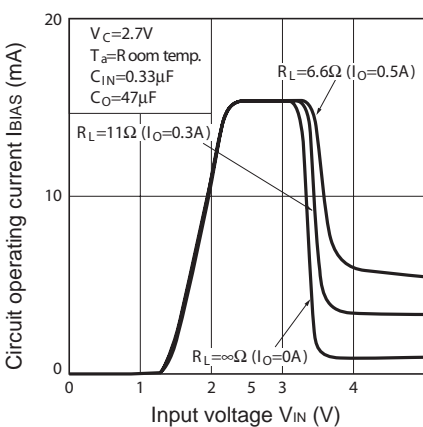

Fig.34 Circuit Operating Current vs. Input Voltage (PQ015EZ01ZxH)

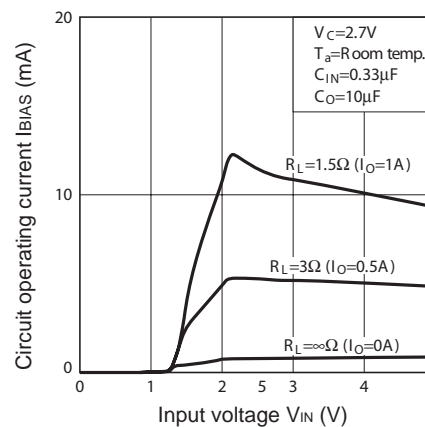

Fig.35 Circuit Operating Current vs. Input Voltage (PQ018EZ01ZxH)

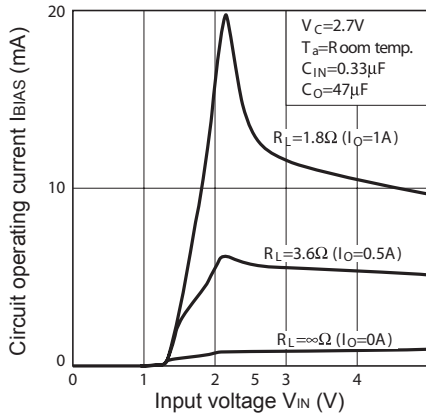

Fig.36 Circuit Operating Current vs. Input Voltage (PQ025EZ01ZxH)

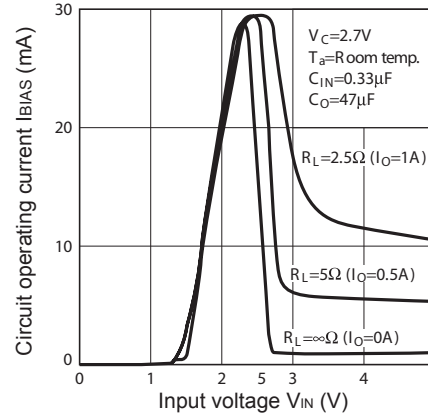

Fig.37 Circuit Operating Current vs. Input Voltage (PQ030EZ01ZxH)

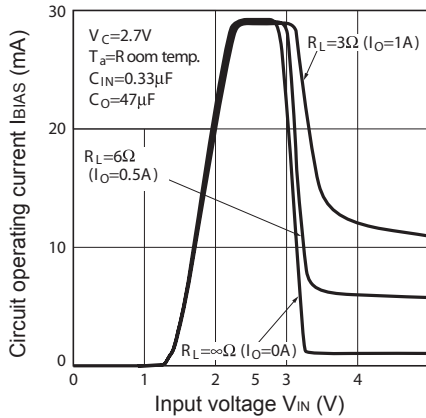

Fig.38 Circuit Operating Current vs. Input Voltage (PQ033EZ01ZxH)

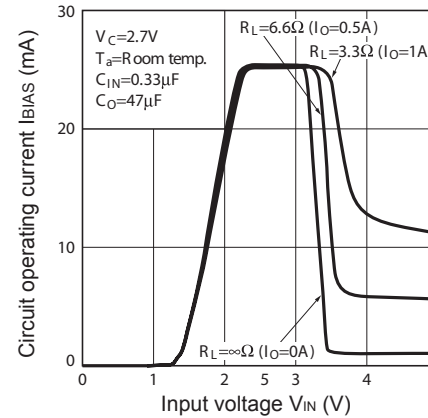

Fig.39 Quiescent Current vs. Junction Temperature

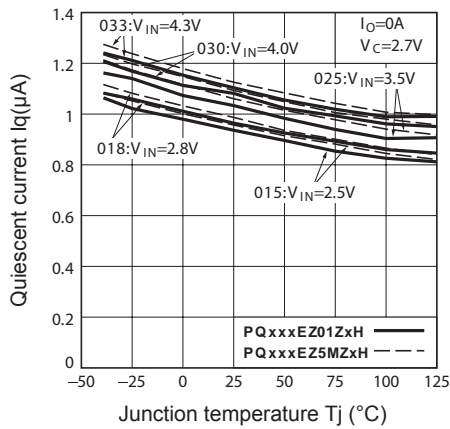

Fig.40 Dropout Voltage vs. Junction Temperature

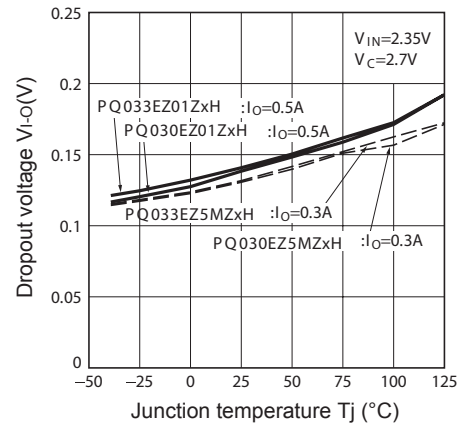

Fig.41 Ripple Rejection vs. Input Ripple Frequency

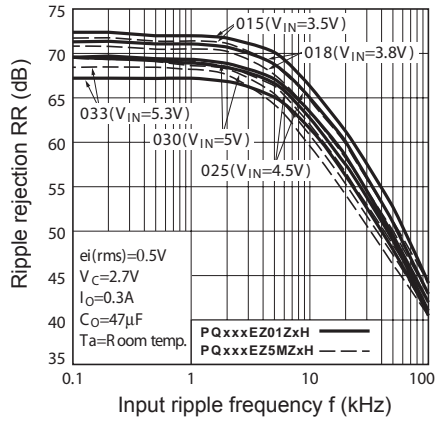

Fig.42 Ripple Rejection vs. Output Current

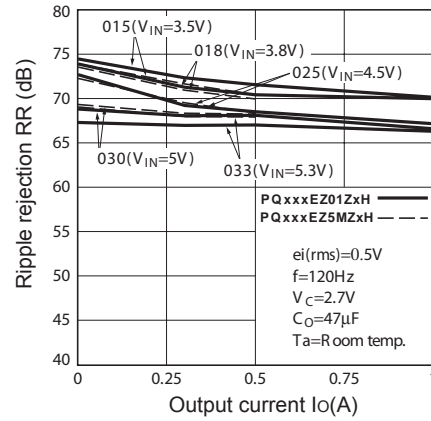

Fig.43 Typical Application

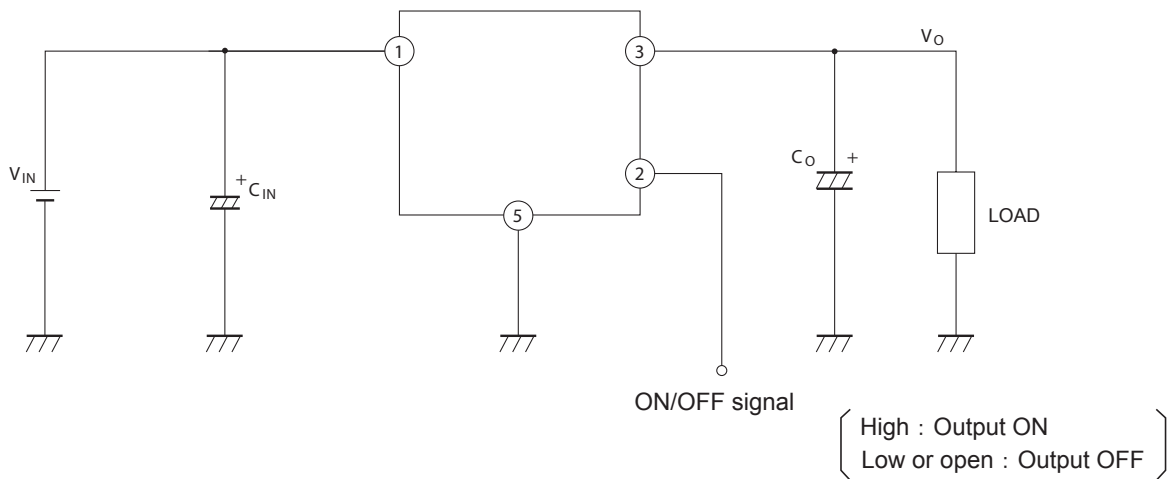
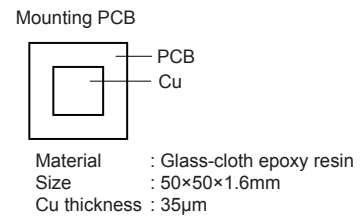
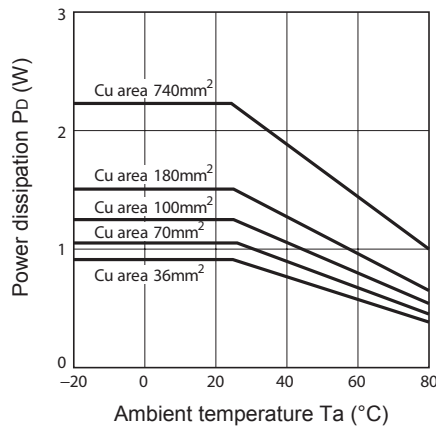

Fig.44 Power Dissipation vs. Ambient Temperature (Typical Value)



## Looking for pricing, stock, or lifecycle information?

Click below to explore more details on WIN SOURCE:

-  [View PQ025EZ01ZZH on WIN SOURCE](#)
-  [Sharp Microelectronics](#) Information

## Optimize Your Supply Chain with WIN SOURCE Solutions

-  Global Sourcing Solution
-  Obsolete Management
-  Cost Control Management
-  Shortage Management
-  Alternative Solution
-  Excess Inventory Management