



**THE DATASHEET OF  
CY24293ZXCT**



# Two Outputs PCI-Express Clock Generator

## Features

- 25 MHz crystal or clock input
- Two sets of differential PCI-Express clocks
- Pin selectable output frequencies
- Supports HCSL compatible output levels
- Spread Spectrum capability on all output clocks with pin selectable spread range
- 16-pin TSSOP package
- Operating voltage 3.3 V
- Commercial, Industrial operating temperature range

## Functional Description

CY24293 is a two output PCI-Express clock generator device intended for networking applications. The device takes 25 MHz crystal or clock input and provides two pairs of differential outputs at 25 MHz, 100 MHz, 125 MHz, or 200 MHz for HCSL signaling standard.

The device incorporates Lexmark Spread Spectrum profile for maximum electromagnetic interference (EMI) reduction. The spread type and amount can be selected using select pins.

For a complete list of related documentation, click [here](#).

## Logic Block Diagram

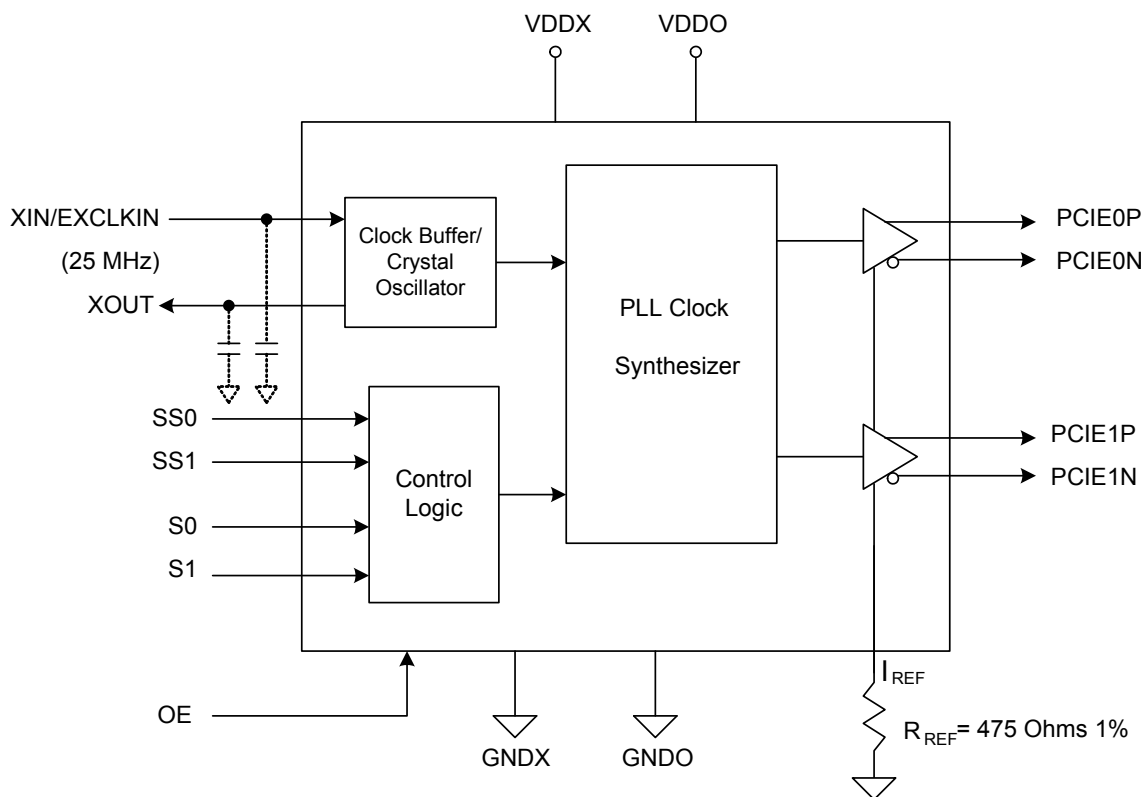

## Contents

<b>Pinouts</b> .....	<b>3</b>	<b>AC Electrical Characteristics</b> .....	<b>8</b>
<b>Pin Definitions</b> .....	<b>3</b>	<b>AC Electrical Characteristics</b> .....	<b>9</b>
<b>Output Frequency Selection Table</b> .....	<b>4</b>	<b>Test and Measurement Setup</b> .....	<b>9</b>
<b>Spread Selection Table</b> .....	<b>4</b>	<b>Ordering Information</b> .....	<b>10</b>
<b>Application Information</b> .....	<b>5</b>	Ordering Code Definitions .....	10
Crystal Recommendations .....	5	<b>Package Diagram</b> .....	<b>11</b>
Crystal Loading .....	5	<b>Acronyms</b> .....	<b>12</b>
Calculating Load Capacitors .....	5	<b>Document Conventions</b> .....	<b>12</b>
Current Source (Iref) Reference Resistor .....	5	Units of Measure .....	12
Output Termination .....	6	<b>Document History Page</b> .....	<b>13</b>
Decoupling Capacitors .....	6	<b>Sales, Solutions, and Legal Information</b> .....	<b>15</b>
<b>PCI-Express (HCSL Compatible) Layout Guidelines</b> ....	<b>6</b>	Worldwide Sales and Design Support .....	15
<b>Absolute Maximum Ratings</b> .....	<b>7</b>	Products .....	15
<b>Recommended Operation Conditions</b> .....	<b>7</b>	PSoC® Solutions .....	15
<b>DC Electrical Characteristics</b> .....	<b>7</b>	Cypress Developer Community .....	15
<b>Thermal Resistance</b> .....	<b>7</b>	Technical Support .....	15

## Pinouts

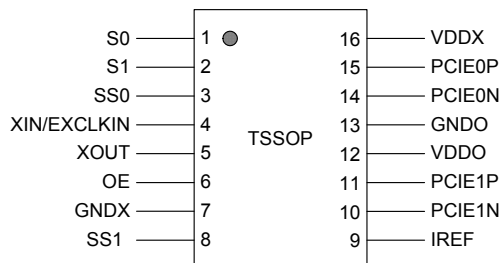
**Figure 1. 16-pin TSSOP pinout**

## Pin Definitions

### 16-pin TSSOP

Pin Number	Pin Name	Pin Type	Description
1	S0	Input	Frequency select pin. Has internal weak pull-up. Refer to <a href="#">Output Frequency Selection Table on page 4</a> .
2	S1	Input	Frequency select pin. Has internal weak pull-up. Refer to <a href="#">Output Frequency Selection Table on page 4</a> .
3	SS0 <sup>[1]</sup>	Input	Spread spectrum select pin 0. Has internal weak pull-up. Refer to <a href="#">Spread Selection Table on page 4</a> .
4	XIN/EXCLKIN	Input	Crystal or clock input. 25 MHz fundamental mode crystal or clock input.
5	XOUT	Output	Crystal output. 25 MHz fundamental mode crystal input. Float for clock input.
6	OE	Input	High true output enable pin. When set low, PCI-E outputs are tri-stated. Has internal weak pull-up.
7	GNDX	Power	Ground
8	SS1 <sup>[1]</sup>	Input	Spread spectrum select pin 1. has internal weak pull-up. Refer to <a href="#">Spread Selection Table on page 4</a> .
9	IREF	Output	Current set for all differential clock drivers. Connect 475 $\Omega$ resistor to ground.
10	PCIE1N	Output	Differential PCI-Express complementary clock output. Tristated when disabled.
11	PCIE1P	Output	Differential PCI-Express true clock output. Tristated when disabled.
12	VDDO <sup>[2]</sup>	Input	3.3 V Power supply for output driver and analog circuits.
13	GNDO	Power	Ground
14	PCIE0N	Output	Differential PCI-Express complementary clock output. Tristated when disabled.
15	PCIE0P	Output	Differential PCI-Express true clock output. Tristated when disabled.
16	VDDX <sup>[2]</sup>	Input	3.3 V Power supply for oscillator and digital circuits.

#### Notes

1. Once powered up, state of SS1/SS0 pins should be held constant at the desired state.
2. VDDX must be supplied faster or equal to VDDO.

**Output Frequency Selection Table**

S1	S0	PCIE0[N,P], PCIE1[N,P]
0	0	25 MHz
0	1	100 MHz
1	0	125 MHz
1	1	200 MHz

**Spread Selection Table**

SS1 <sup>[3]</sup>	SS0 <sup>[3]</sup>	Spread%
0	0	No Spread
0	1	-0.5%
1	0	-0.75%
1	1	No Spread

**Note**

3. Once powered up, state of SS1/SS0 pins should be held constant at the desired state.



**Output Termination**

The PCI-Express differential clock outputs of the CY24293 are open source drivers and require an external series resistor and a resistor to ground. These resistor values and their allowable locations are explained in Figure 4.

**PCB Layout Recommendations**

For optimum device performance and the lowest phase noise, the following guidelines must be observed:

1. Each 0.01  $\mu\text{F}$  decoupling capacitor must be mounted on the component side of the board as close to the  $V_{DD}$  pin as possible.
2. No vias must be used between the decoupling capacitor and the  $V_{DD}$  pin.

3. The PCB trace to the  $V_{DD}$  pin and the ground via must be kept as short as possible. Distance of the ferrite bead and bulk decoupling from the device is less critical.
4. An optimum layout is one with all components on the same side of the board, minimizing vias through other signal layers (any ferrite beads and bulk decoupling capacitors can be mounted on the back). Other signal traces must be routed away from the CY24293. This includes signal traces just underneath the device, or on layers adjacent to the ground plane layer used by the device.

**Decoupling Capacitors**

The decoupling capacitors of 0.01  $\mu\text{F}$  must be connected between  $V_{DD}$  and GND as close to the device as possible. Do not share ground vias between components. Route power from the power source through the capacitor pad and then into the CY24293 pin.

**PCI-Express (HCSL Compatible) Layout Guidelines**

**Table 2. Common Recommendations for Differential Routing**

Differential Routing	Dimension or Value	Unit
L1 length, route as non-coupled 50 $\Omega$ trace	0.5 max	inch
L2 length, route as non-coupled 50 $\Omega$ trace	0.2 max	inch
L3 length, route as non-coupled 50 $\Omega$ trace	0.2 max	inch
$R_S$	33	$\Omega$
$R_T$	49.9	$\Omega$

**Table 3. Differential Routing for PCI-Express Load or Connector**

Differential Routing	Dimension or Value	Unit
L4 length, route as coupled microstrip 100 $\Omega$ differential trace	2 to 32	inch
L4 length, route as coupled stripline 100 $\Omega$ differential trace	1.8 to 30	inch

**Figure 4. PCI-Express Differential Routing**

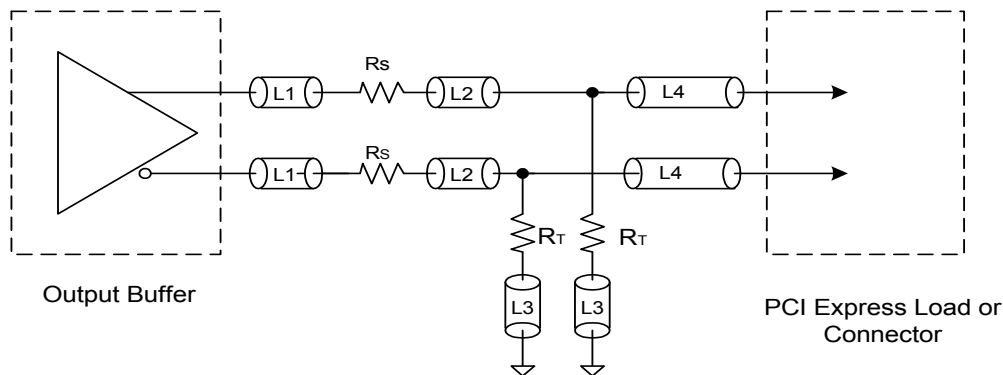

## Absolute Maximum Ratings

Exceeding maximum ratings may shorten the useful life of the device. User guidelines are not tested.

Parameter	Description	Condition	Min	Max	Unit
V <sub>DD</sub>	Supply voltage		-0.5	4.6	V
V <sub>IN</sub>	Input voltage	Relative to V <sub>SS</sub>	-0.5	V <sub>DD</sub> + 0.5	V
T <sub>S</sub>	Temperature, Storage	Non Functional	-65	+150	°C
T <sub>J</sub>	Temperature, Junction	Non Functional	-65	+150	°C
ESD <sub>HBM</sub>	ESD Protection (Human Body Model)	JEDEC EIA/JESD22-A114-E	2000	-	V
UL-94	Flammability rating	-	V-0 at 1/8 in.		
MSL	Moisture sensitivity level	-	3		

## Recommended Operation Conditions

Parameter	Description	Min	Typ	Max	Unit
V <sub>DD</sub>	Supply voltage	3.0	-	3.6	V
T <sub>AC</sub>	Commercial ambient temperature	0	-	+70	°C
T <sub>AI/AA</sub>	Industrial ambient temperature	-40	-	+85	°C
t <sub>PU</sub>	Power up time for all V <sub>DD</sub> to reach minimum specified voltage (power ramps must be monotonic)	0.05	-	500	ms

## DC Electrical Characteristics

Unless otherwise stated, V<sub>DD</sub> = 3.3 V ± 0.3 V, ambient temperature = -40 °C to +85 °C Industrial, 0 °C to +70 °C Commercial

Parameter <sup>[4]</sup>	Description	Condition	Min	Typ	Max	Unit
V <sub>IL</sub>	Input low voltage	-	-0.3	-	0.8	V
V <sub>IH</sub>	Input high voltage	-	2.0	-	V <sub>DD</sub> + 0.3	V
V <sub>OL</sub>	Output low voltage of PCIE0[P/N], PCIE1[P/N]	HCSL termination (R <sub>S</sub> = 33 Ω, R <sub>T</sub> = 49.9 Ω). See note 19.	-0.2	0	0.05	V
V <sub>OH</sub>	Output high voltage of PCIE0[P/N], PCIE1[P/N]	HCSL termination (R <sub>S</sub> = 33 Ω, R <sub>T</sub> = 49.9 Ω). See note 19.	0.65	0.71	0.95	V
I <sub>DD</sub>	Operating supply current	No load, OE = 1	-	45	60	mA
I <sub>DDOD</sub>	Output disabled current	OE = 0	-	-	50	mA
C <sub>IN</sub>	Input capacitance	All input pins	-	5	-	pF
R <sub>PU</sub>	Pull-up resistance	S0, S1, SS0, SS1, OE	-	70k	-	Ω

## Thermal Resistance

Parameter <sup>[6]</sup>	Description	Test Conditions	16-pin TSSOP	Unit
θ <sub>JA</sub>	Thermal resistance (junction to ambient)	Test conditions follow standard test methods and procedures for measuring thermal impedance, in accordance with EIA/JESD51.	89	°C/W
θ <sub>JC</sub>	Thermal resistance (junction to case)		12	°C/W

### Note

- Parameters are guaranteed by design and characterization. Not 100% tested in production.
- These parameters are guaranteed by design and are not tested.

## AC Electrical Characteristics

Unless otherwise stated:  $V_{DD} = 3.3 \text{ V} \pm 0.3 \text{ V}$ , ambient temperature =  $-40 \text{ }^\circ\text{C}$  to  $+85 \text{ }^\circ\text{C}$  Industrial,  $0 \text{ }^\circ\text{C}$  to  $+70 \text{ }^\circ\text{C}$  Commercial, Outputs HCSL terminated.

Parameter <sup>[6]</sup>	Description	Condition	Min	Typ	Max	Unit
$F_{IN}$	Input clock frequency (crystal or external clock)	–	–	25	–	MHz
$T_{INDC}$	Input clock duty cycle	–	40	–	60	%
$F_{OUT}$	Output frequency	HCSL termination	–	–	200	MHz
$F_{ERR}$	Frequency synthesis error	–	–	0	–	ppm
$T_{CCJ}$	Cycle-to-cycle jitter	See notes 7, 8	–	–	75	ps
$SP_{PROFILE}$	Spread modulation profile	–	–	–	Lexmark	type
$SP_{MOD}$	Spread modulation frequency	–	30	32	33	kHz
$T_{DC}$	Output clock duty cycle	See notes: 7, 9	45	50	55	%
$T_{OEHL}$	Output enable time	OE going high to differential outputs becoming valid	–	–	200	ns
$T_{OEL}$	Output disable time	OE going low to differential outputs becoming invalid	–	–	200	ns
$T_{LOCK}$	Clock stabilization from power up	Measured from 90% of the applied power supply level	–	1	2	ms
$T_R$	Output rise time	Measured from 0.175 V to 0.525 V. See notes: 7, 10	130	–	700	ps
$T_F$	Output fall time	Measured from 0.525 V to 0.175 V. See notes: 7, 10	130	–	700	ps
$DT_R$	Rise time variation	For a given frequency, Max ( $T_R$ ) – Min ( $T_R$ )	–	–	125	ps
$DT_F$	Fall time variation	For a given frequency, Max ( $T_F$ ) – Min ( $T_F$ )	–	–	125	ps
$T_{OSKEW}$	Output skew	Measured at $V_{CROSS}$ point. See note: 11	–	–	50	ps
$V_{CROSS}$	Absolute crossing point voltage	See notes: 9, 10, 12	0.25	0.35	0.55	V
$V_{Xdelta}$	Variation of $V_{CROSS}$ over all rising clock edges	See notes: 9, 10, 13	–	–	140	mV

### Notes

6. Parameters are guaranteed by design and characterization. Not 100% tested in production.
7. Measured with  $C_{load} = 4 \text{ pF}$  max. (scope probe + trace load).
8. Measurement taken from differential waveform (PCIEP minus PCIEN). Either single ended probes with math or a differential probe can be used.
9. Measured at crossing point where the instantaneous voltage value of the rising edge of PCIEP equals the falling edge of PCIEN.
10. Measurement taken from single ended waveform.
11. Measured at the rising 0V point of the differential signal. Skew is the time difference of the rising 0V point between any two differential signal pairs. The measurement is taken over 1000 samples, and the average value is used.
12. Refers to the total variation from the lowest crossing point to the highest, regardless of which edge is crossing. Refers to all crossing points for this measurement.
13. Defined as the total variation of all crossing voltages of Rising PCIEP and Falling PCIEN. This is the maximum allowed variance in  $V_{CROSS}$  for any particular system.

## AC Electrical Characteristics

Differential 100 MHz, HCSL Terminated Outputs (Parameters for the PCI Express Specification. Use above AC Characteristics parameter where it is not listed in this section)

Parameter	Description	Test Conditions	Min	Typ	Max	Units
F <sub>OUT</sub>	Output frequency		–	–	100	MHz
T <sub>PHJ</sub>	Peak-to-peak phase jitter	10 <sup>-6</sup> BER. Note: 14	–	30	86	ps
ER <sub>R</sub>	Rising edge rate	See notes: 15, 16	0.6	1.3	4.0	V/ns
ER <sub>F</sub>	Falling edge rate	See notes: 15, 16	0.6	1.3	4.0	V/ns
T <sub>PERIOD AVG</sub>	Average clock period accuracy	See notes: 15, 17	-300	–	2800	ppm
T <sub>PERIOD ABS</sub>	Absolute clock period	See notes: 15, 18	9.847	–	10.203	ns
RF <sub>MATCHING</sub>	Rising edge rate to falling edge rate matching	See note: 19, 20	–	–	20	%

## Test and Measurement Setup

Figure 5. Test Load Configuration for Differential Output Signals

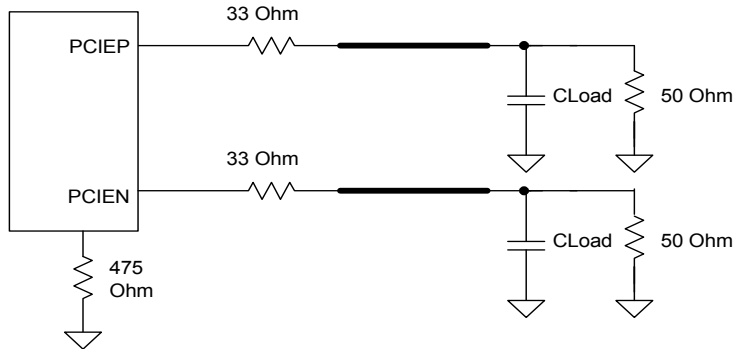

### Notes

14. Phase jitter is determined using data captured on an oscilloscope at a sample rate of 20 GS/sec, for a minimum 100,000 continuous clock periods. This data is then processed using the ClockJitter 1.3.0 software from PCISIG, using the PCI\_E\_1\_1 template.
15. Measurement taken from differential waveform (PCIEP minus PCIEEN). Either single ended probes with math or a differential probe can be used.
16. Measured from -150 mV to +150 mV on the differential waveform (derived from PCIEP minus PCIEEN). The signal must be monotonic through the measurement region for rise and fall time. The 300 mV measurement window is centered on the differential zero crossing.
17. PPM refers to parts per million and is a DC absolute period accuracy specification. The period is to be measured with a frequency counter with measurement window set to 100 ms or greater. The ±300 PPM applies to systems that do not employ Spread Spectrum or that use common clock source. For systems employing Spread Spectrum, there is an additional 2500 PPM nominal shift in maximum period resulting from the 0.5% down spread, resulting in a maximum average period specification of +2800 PPM.
18. Defined as the absolute minimum or maximum instantaneous period. This includes cycle-to-cycle jitter, relative PPM tolerance, and spread spectrum modulation.
19. Measurement taken from single ended waveform.
20. Matching applies to rising edge rate for PCIEP and falling edge for PCIEEN. It is measured using a ± 75mV window centered on the median cross point where PCIEP rising meets PCIEEN falling.

### Ordering Information

Part Number	Type	Production Flow
<b>Pb-free</b>		
CY24293ZXC	16-pin TSSOP	Commercial, 0 °C to 70 °C
CY24293ZXCT	16-pin TSSOP – Tape and Reel	Commercial, 0 °C to 70 °C
CY24293ZXI	16-pin TSSOP	Industrial, –40 °C to 85 °C
CY24293ZXIT	16-pin TSSOP – Tape and Reel	Industrial, –40 °C to 85 °C

### Ordering Code Definitions

CY 24293 Z X X X

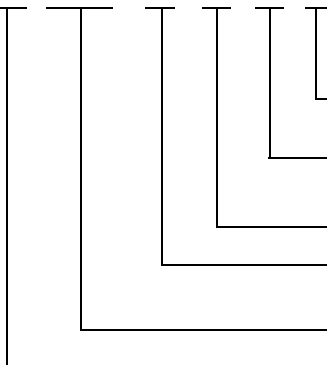

- X = T or blank
- T = Tape and Reel; blank = Tube
- Temperature Range:
- X = C or I; C = Commercial; I = Industrial
- Pb-free
- Package Type:
- Z = 16-pin TSSOP
- Base Device Part Number
- Company ID: CY = Cypress



## Acronyms

Acronym	Description
EIA	electronic industries alliance
EMI	electromagnetic interference
ESD	electrostatic discharge
HCSL	high speed current steering logic
JEDEC	joint electron devices engineering council
PCB	printed circuit board
PCI	peripheral component interconnect
PLL	phase-locked loop
TSSOP	thin shrunk small outline package

## Document Conventions

### Units of Measure

Symbol	Unit of Measure
°C	degree Celsius
kHz	kilohertz
MHz	megahertz
μF	microfarad
mA	milliampere
ms	millisecond
mV	millivolt
mW	milliwatt
ns	nanosecond
Ω	ohm
ppm	parts per million
%	percent
pF	picofarad
ps	picosecond
V	volt

**Document History Page**

Document Title: CY24293, Two Outputs PCI-Express Clock Generator				
Document Number: 001-46117				
Rev.	ECN No.	Orig. of Change	Submission Date	Description of Change
**	2490167	PYG/DPF/AESA	See ECN	New data sheet.
*A	2507681	DPF / AESA	05/23/2008	Added Note 1: Parameters are guaranteed by design and characterization. Not 100% tested in production. Added Note 2 for Duty cycle spec in the AC Elect. Characteristics. Added HCSL termination in Condition for $V_{OL}$ , $V_{OH}$ DC Elect. Char. Added $V_{Xdelta}$ value of 140 mV in the Differential 100 MHz HCSL output. Changed Cload from 2 pF to 4 pF in Note 2. Added internal weak Pull-ups for S0, S1, SS0, SS1 and OE pins. Updated $T_{OEHL}$ and $T_{OEL}$ to 200 ns (max.). Updated to new template.
*B	2621901	CXQ / AESA	12/19/2008	Updated $I_{DD}$ spec in DC Electrical Characteristics. Added max spec for $I_{DDOD}$ DC Electrical Characteristics. Added $R_{PU}$ in DC Electrical Characteristics. Replaced $T_{REFVAR}$ with $DT_R$ and $DT_F$ in AC Electrical Characteristics. Added definitions for rise and fall time variation, crossing point variation in AC Electrical Characteristics. Reduced cycle-to-cycle jitter spec to 75ps in AC Electrical Characteristics.
*C	2683343	CXQ / PYRA	04/03/2009	Changed status from Preliminary to Final. Added "max" to crystal ESR spec. Changed "LVDS Down Device" to "LVDS Device" in Table 8 and Figure 4.
*D	3289802	BASH	06/27/2011	Added <a href="#">Ordering Code Definitions</a> . Updated <a href="#">Package Diagram</a> . Added <a href="#">Acronyms</a> and <a href="#">Units of Measure</a> . Updated to new template.
*E	3395894	PURU	10/05/2011	Updated <a href="#">Features</a> (Removed LVDS related information). Updated <a href="#">Functional Description</a> (Removed LVDS related information). Updated <a href="#">Output Termination</a> under <a href="#">Application Information</a> (Removed LVDS related information). Removed the section LVDS Compatible Layout Guidelines under the main section <a href="#">PCI-Express (HCSL Compatible) Layout Guidelines</a> . Updated <a href="#">AC Electrical Characteristics</a> (Removed LVDS related information). Updated <a href="#">Package Diagram</a> . Updated to new template.
*F	4467398	XHT	08/08/2014	Updated <a href="#">DC Electrical Characteristics</a> : Changed maximum value of $V_{OH}$ parameter from 0.85 V to 0.95 V.
*G	4581659	TAVA	11/28/2014	Updated <a href="#">Functional Description</a> : Added "For a complete list of related documentation, click <a href="#">here</a> ." at the end. Updated <a href="#">Package Diagram</a> .

Document History Page (continued)

Document Title: CY24293, Two Outputs PCI-Express Clock Generator Document Number: 001-46117				
Rev.	ECN No.	Orig. of Change	Submission Date	Description of Change
*H	4817220	XHT	07/25/2015	<p>Updated <a href="#">Pin Definitions</a>:            Added Note 1 and referred the same note in SS0 and SS1 pins.            Added Note 2 and referred the same note in VDDO and VDDX pins.            Updated <a href="#">Spread Selection Table</a>:            Added Note 3 and referred the same note in "SS1" and "SS0" columns.            Updated <a href="#">Application Information</a>:            Updated <a href="#">Current Source (Iref) Reference Resistor</a>:            Updated description.            Added <a href="#">Figure 3</a>.            Updated <a href="#">AC Electrical Characteristics</a>:            Added SP<sub>PROFILE</sub> parameter and its details.            Added minimum value of SP<sub>MOD</sub> parameter (30 kHz).            Added maximum value of SP<sub>MOD</sub> parameter (33 kHz).            Updated Note 10 (Replaced differential with single ended).            Added <a href="#">AC Electrical Characteristics</a> (to specify PCIe parameter specifications).            Updated to new template.            Completing Sunset Review.</p>
*I	5281627	PSR	05/23/2016	<p>Added <a href="#">Thermal Resistance</a>.            Updated to new template.</p>
*J	5787395	PSR	06/27/2017	<p>Updated <a href="#">AC Electrical Characteristics</a>: Added T<sub>INDC</sub> parameter.            Updated template.</p>

## Sales, Solutions, and Legal Information

### Worldwide Sales and Design Support

Cypress maintains a worldwide network of offices, solution centers, manufacturer's representatives, and distributors. To find the office closest to you, visit us at [Cypress Locations](#).

#### Products

ARM <sup>®</sup> Cortex <sup>®</sup> Microcontrollers	<a href="http://cypress.com/arm">cypress.com/arm</a>
Automotive	<a href="http://cypress.com/automotive">cypress.com/automotive</a>
Clocks & Buffers	<a href="http://cypress.com/clocks">cypress.com/clocks</a>
Interface	<a href="http://cypress.com/interface">cypress.com/interface</a>
Internet of Things	<a href="http://cypress.com/iot">cypress.com/iot</a>
Memory	<a href="http://cypress.com/memory">cypress.com/memory</a>
Microcontrollers	<a href="http://cypress.com/mcu">cypress.com/mcu</a>
PSoC	<a href="http://cypress.com/psoc">cypress.com/psoc</a>
Power Management ICs	<a href="http://cypress.com/pmic">cypress.com/pmic</a>
Touch Sensing	<a href="http://cypress.com/touch">cypress.com/touch</a>
USB Controllers	<a href="http://cypress.com/usb">cypress.com/usb</a>
Wireless Connectivity	<a href="http://cypress.com/wireless">cypress.com/wireless</a>

#### PSoC<sup>®</sup> Solutions

[PSoC 1](#) | [PSoC 3](#) | [PSoC 4](#) | [PSoC 5LP](#) | [PSoC 6](#)

#### Cypress Developer Community

[Forums](#) | [WICED IOT Forums](#) | [Projects](#) | [Video](#) | [Blogs](#) | [Training](#) | [Components](#)

#### Technical Support

[cypress.com/support](http://cypress.com/support)

---



© Cypress Semiconductor Corporation, 2008-2017. This document is the property of Cypress Semiconductor Corporation and its subsidiaries, including Spansion LLC ("Cypress"). This document, including any software or firmware included or referenced in this document ("Software"), is owned by Cypress under the intellectual property laws and treaties of the United States and other countries worldwide. Cypress reserves all rights under such laws and treaties and does not, except as specifically stated in this paragraph, grant any license under its patents, copyrights, trademarks, or other intellectual property rights. If the Software is not accompanied by a license agreement and you do not otherwise have a written agreement with Cypress governing the use of the Software, then Cypress hereby grants you a personal, non-exclusive, nontransferable license (without the right to sublicense) (1) under its copyright rights in the Software (a) for Software provided in source code form, to modify and reproduce the Software solely for use with Cypress hardware products, only internally within your organization, and (b) to distribute the Software in binary code form externally to end users (either directly or indirectly through resellers and distributors), solely for use on Cypress hardware product units, and (2) under those claims of Cypress's patents that are infringed by the Software (as provided by Cypress, unmodified) to make, use, distribute, and import the Software solely for use with Cypress hardware products. Any other use, reproduction, modification, translation, or compilation of the Software is prohibited.

TO THE EXTENT PERMITTED BY APPLICABLE LAW, CYPRESS MAKES NO WARRANTY OF ANY KIND, EXPRESS OR IMPLIED, WITH REGARD TO THIS DOCUMENT OR ANY SOFTWARE OR ACCOMPANYING HARDWARE, INCLUDING, BUT NOT LIMITED TO, THE IMPLIED WARRANTIES OF MERCHANTABILITY AND FITNESS FOR A PARTICULAR PURPOSE. To the extent permitted by applicable law, Cypress reserves the right to make changes to this document without further notice. Cypress does not assume any liability arising out of the application or use of any product or circuit described in this document. Any information provided in this document, including any sample design information or programming code, is provided only for reference purposes. It is the responsibility of the user of this document to properly design, program, and test the functionality and safety of any application made of this information and any resulting product. Cypress products are not designed, intended, or authorized for use as critical components in systems designed or intended for the operation of weapons, weapons systems, nuclear installations, life-support devices or systems, other medical devices or systems (including resuscitation equipment and surgical implants), pollution control or hazardous substances management, or other uses where the failure of the device or system could cause personal injury, death, or property damage ("Unintended Uses"). A critical component is any component of a device or system whose failure to perform can be reasonably expected to cause the failure of the device or system, or to affect its safety or effectiveness. Cypress is not liable, in whole or in part, and you shall and hereby do release Cypress from any claim, damage, or other liability arising from or related to all Unintended Uses of Cypress products. You shall indemnify and hold Cypress harmless from and against all claims, costs, damages, and other liabilities, including claims for personal injury or death, arising from or related to any Unintended Uses of Cypress products.

Cypress, the Cypress logo, Spansion, the Spansion logo, and combinations thereof, WICED, PSoC, CapSense, EZ-USB, F-RAM, and Traveo are trademarks or registered trademarks of Cypress in the United States and other countries. For a more complete list of Cypress trademarks, visit [cypress.com](http://cypress.com). Other names and brands may be claimed as property of their respective owners.

## Looking for pricing, stock, or lifecycle information?

Click below to explore more details on WIN SOURCE:

-  [View CY24293ZXCT on WIN SOURCE](#)
-  [Cypress Semiconductor Corp Information](#)

## Optimize Your Supply Chain with WIN SOURCE Solutions

-  Global Sourcing Solution
-  Obsolete Management
-  Cost Control Management
-  Shortage Management
-  Alternative Solution
-  Excess Inventory Management