



**THE DATASHEET OF
LM3411AM5-5.0/NOPB**



LM3411 Precision Secondary Regulator and Driver

1 Features

- Fixed Voltages of 3.3 V and 5 V With Initial Tolerance of $\pm 1\%$ for Standard Grade and $\pm 0.5\%$ for A Grade
- Custom Voltages Available (3 V to 17 V)
- Wide Output Current Range (20 μA to 15 mA)
- Low Temperature Coefficient
- Available in 5-Pin SOT-23 Surface-Mount Package (Tape and Reel)

2 Applications

- Secondary Controller for Isolated DC-DC PWM Switching Regulators Systems
- Use With LDO Regulator for High-Precision, Fixed-Output Regulators
- Precision Monitoring Applications
- Use With Many Types of Regulators to Increase Precision and Improve Performance

3 Description

The LM3411 is a low-power fixed-voltage (3.3 V or 5 V) precision shunt regulator designed specifically for driving an optoisolator to provide feedback isolation in a switching regulator.

The LM3411 circuitry includes an internally compensated operational amplifier, a bandgap reference, NPN output transistor, and voltage setting resistors.

A trimmed precision bandgap reference with temperature drift curvature correction provides a ensured 1% precision over the operating temperature range (A grade version). The inverting input of the amplifier is externally accessible for loop frequency compensation when used as part of a larger servo system. The output is an open-emitter NPN transistor capable of driving up to 15 mA of load current.

Because of its small die size, the LM3411 has been made available in the subminiature 5-pin SOT-23 surface-mount package. This package is ideal for use in space-critical applications.

Although its main application is to provide a precision output voltage (no trimming required) and maintain very good regulation in isolated DC-DC converters, it can also be used with other types of voltage regulators or power semiconductors to provide a precision output voltage without precision resistors or trimming.

Device Information⁽¹⁾

PART NUMBER	PACKAGE	BODY SIZE (NOM)
LM3411	SOT-23 (5)	2.90 mm x 1.60 mm

(1) For all available packages, see the orderable addendum at the end of the data sheet.

Typical Application Schematic

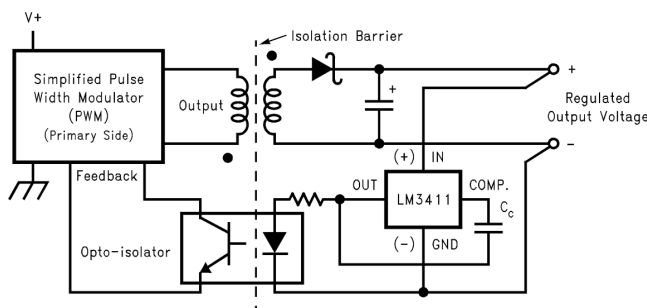

Copyright © 2016, Texas Instruments Incorporated

LM3411 Functional Diagram

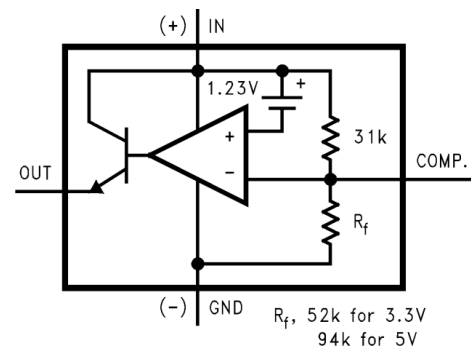

Copyright © 2016, Texas Instruments Incorporated



Table of Contents

1 Features 1 2 Applications 1 3 Description 1 4 Revision History 2 5 Pin Configuration and Functions 3 6 Specifications 4 6.1 Absolute Maximum Ratings 4 6.2 ESD Ratings 4 6.3 Recommended Operating Conditions 4 6.4 Thermal Information 4 6.5 Electrical Characteristics: 3.3-V Version 5 6.6 Electrical Characteristics: 5-V Version 6 6.7 Typical Characteristics 7 7 Parameter Measurement Information 9 8 Detailed Description 11 8.1 Overview 11 8.2 Functional Block Diagrams 11	8.3 Feature Description 12 8.4 Device Functional Modes 12 9 Application and Implementation 13 9.1 Application Information 13 9.2 Typical Applications 13 10 Power Supply Recommendations 24 11 Layout 24 11.1 Layout Guidelines 24 11.2 Layout Example 24 12 Device and Documentation Support 25 12.1 Documentation Support 25 12.2 Community Resources 25 12.3 Trademarks 25 12.4 Electrostatic Discharge Caution 25 12.5 Glossary 25 13 Mechanical, Packaging, and Orderable Information 25
--	---

4 Revision History

NOTE: Page numbers for previous revisions may differ from page numbers in the current version.

Changes from Revision E (April 2013) to Revision F	Page
<ul style="list-style-type: none"> • Added <i>ESD Ratings</i> table, <i>Feature Description</i> section, <i>Device Functional Modes</i>, <i>Application and Implementation</i> section, <i>Power Supply Recommendations</i> section, <i>Layout</i> section, <i>Device and Documentation Support</i> section, and <i>Mechanical, Packaging, and Orderable Information</i> section 1 	1

Changes from Revision D (April 2013) to Revision E	Page
<ul style="list-style-type: none"> • Changed layout of National Semiconductor Data Sheet to TI format 12 	12

5 Pin Configuration and Functions

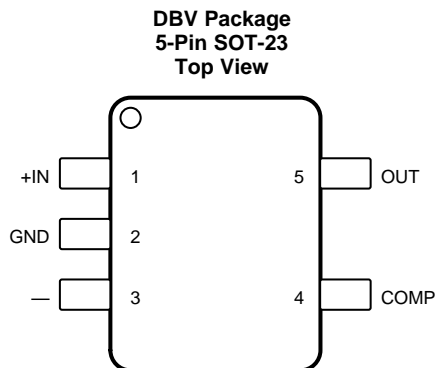

Pin Functions

PIN		I/O	DESCRIPTION
NO.	NAME		
1	+IN	I	Output measurement pin
2	GND	I/O	Ground pin
3	—	—	No internal connection, but must be soldered to printed-circuit board for best heat transfer.
4	COMP	I/O	Operational amplifier inverting input pin
5	OUT	O	Optocoupler drive pin

6 Specifications

6.1 Absolute Maximum Ratings

over operating free-air temperature range (unless otherwise noted)⁽¹⁾⁽²⁾

		MIN	MAX	UNIT
Input voltage, V_{IN}			20	V
Output current			20	mA
Power dissipation ($T_A = 25^\circ\text{C}$) ⁽³⁾			300	mW
Lead temperature	Vapor phase (60 s)		215	°C
	Infrared (15 s)		220	
Junction temperature			150	°C
Storage temperature, T_{stg}		-65	150	°C

- Stresses beyond those listed under *Absolute Maximum Ratings* may cause permanent damage to the device. These are stress ratings only, which do not imply functional operation of the device at these or any other conditions beyond those indicated under *Recommended Operating Conditions*. Exposure to absolute-maximum-rated conditions for extended periods may affect device reliability.
- See AN-450 *Surface Mounting Methods and Their Effect on Product Reliability* (SNOA742) for methods on soldering surface-mount devices.
- The maximum power dissipation must be derated at elevated temperatures and is dictated by T_{Jmax} (maximum junction temperature), $R_{\theta JA}$ (junction to ambient thermal resistance), and T_A (ambient temperature). The maximum allowable power dissipation at any temperature is $(P_{Dmax} = T_{Jmax} - T_A) / R_{\theta JA}$ or the number given in the *Absolute Maximum Ratings*, whichever is lower. The typical thermal resistance ($R_{\theta JA}$) when soldered to a printed-circuit board is approximately 306°C/W for the DBV package.

6.2 ESD Ratings

			VALUE	UNIT
$V_{(ESD)}$	Electrostatic discharge	Human body model (HBM), per ANSI/ESDA/JEDEC JS-001 ⁽¹⁾	±1500	V

- JEDEC document JEP155 states that 500-V HBM allows safe manufacturing with a standard ESD control process.

6.3 Recommended Operating Conditions

over operating free-air temperature range (unless otherwise noted)⁽¹⁾

		MIN	NOM	MAX	UNIT
V_I	Input voltage	LM3411x 3.3-V	3.3		V
		LM3411x 5-V	5		
I_O	Output current	0		15	mA
T_A	Ambient temperature	-40		85	°C
T_J	Operating junction temperature	-40		125	°C

- The maximum power dissipation must be derated at elevated temperatures and is dictated by T_{Jmax} (maximum junction temperature), $R_{\theta JA}$ (junction to ambient thermal resistance), and T_A (ambient temperature). The maximum allowable power dissipation at any temperature is $(P_{Dmax} = T_{Jmax} - T_A) / R_{\theta JA}$ or the number given in the *Absolute Maximum Ratings*, whichever is lower. The typical thermal resistance ($R_{\theta JA}$) when soldered to a printed-circuit board is approximately 306°C/W for the DBV package.

6.4 Thermal Information

THERMAL METRIC ⁽¹⁾		LM3411	UNIT
		DBV (SOT-23)	
		5 PINS	
$R_{\theta JA}$	Junction-to-ambient thermal resistance	178.6	°C/W
$R_{\theta JC(top)}$	Junction-to-case (top) thermal resistance	134.7	°C/W
$R_{\theta JB}$	Junction-to-board thermal resistance	37.3	°C/W
Ψ_{JT}	Junction-to-top characterization parameter	24.7	°C/W
Ψ_{JB}	Junction-to-board characterization parameter	36.8	°C/W
$R_{\theta JC(bot)}$	Junction-to-case (bottom) thermal resistance	—	°C/W

- For more information about traditional and new thermal metrics, see the *Semiconductor and IC Package Thermal Metrics* application report, SPRA953.

6.5 Electrical Characteristics: 3.3-V Version

Specifications are for $T_J = 25^\circ\text{C}$, $V_{IN} = V_{REG}$, and $V_{OUT} = 1.5\text{ V}$ (unless otherwise noted).

PARAMETER		TEST CONDITIONS		MIN ⁽¹⁾	TYP ⁽²⁾	MAX ⁽¹⁾	UNIT	
V_{REG}	Regulation voltage	$I_{OUT} = 5\text{ mA}$	LM3411A 3.3-V	$T_J = 25^\circ\text{C}$	3.284	3.3	3.317	V
				$-40^\circ\text{C} \leq T_J \leq 125^\circ\text{C}$	3.267		3.333	
			LM3411 3.3-V	$T_J = 25^\circ\text{C}$	3.267	3.3	3.333	
				$-40^\circ\text{C} \leq T_J \leq 125^\circ\text{C}$	3.234		3.366	
	Regulation voltage tolerance	$I_{OUT} = 5\text{ mA}$	LM3411A 3.3-V	$T_J = 25^\circ\text{C}$			$\pm 0.5\%$	
				$-40^\circ\text{C} \leq T_J \leq 125^\circ\text{C}$			$\pm 1\%$	
LM3411 3.3-V	$T_J = 25^\circ\text{C}$			$\pm 1\%$				
	$-40^\circ\text{C} \leq T_J \leq 125^\circ\text{C}$			$\pm 2\%$				
I_q	Quiescent current	$I_{OUT} = 5\text{ mA}$	LM3411A 3.3-V	$T_J = 25^\circ\text{C}$		85	110	μA
				$-40^\circ\text{C} \leq T_J \leq 125^\circ\text{C}$			115	
			LM3411 3.3-V	$T_J = 25^\circ\text{C}$		85	125	
				$-40^\circ\text{C} \leq T_J \leq 125^\circ\text{C}$			150	
G_m	Transconductance $\Delta I_{OUT}/\Delta V_{REG}$	$20\ \mu\text{A} \leq I_{OUT} \leq 1\text{ mA}$	LM3411A 3.3-V	$T_J = 25^\circ\text{C}$	1.5	3.3	mA/mV	
				$-40^\circ\text{C} \leq T_J \leq 125^\circ\text{C}$	0.75			
			LM3411 3.3-V	$T_J = 25^\circ\text{C}$	1	3.3		
				$-40^\circ\text{C} \leq T_J \leq 125^\circ\text{C}$	0.5			
		$1\text{ mA} \leq I_{OUT} \leq 15\text{ mA}$	LM3411A 3.3-V	$T_J = 25^\circ\text{C}$	3.3	6		
				$-40^\circ\text{C} \leq T_J \leq 125^\circ\text{C}$	2			
LM3411 3.3-V	$T_J = 25^\circ\text{C}$	2.5	6					
	$-40^\circ\text{C} \leq T_J \leq 125^\circ\text{C}$	1.7						
A_V	Voltage gain $\Delta V_{OUT}/\Delta V_{REG}$	$R_L = 140\ \Omega^{(3)}$	LM3411A 3.3-V	$T_J = 25^\circ\text{C}$, $1\text{ V} \leq V_{OUT} \leq V_{REG} - 1.2\text{ V}$	550	1000	V/V	
				$-40^\circ\text{C} \leq T_J \leq 125^\circ\text{C}$, $1\text{ V} \leq V_{OUT} \leq V_{REG} - 1.3\text{ V}$	250			
			LM3411 3.3-V	$T_J = 25^\circ\text{C}$, $1\text{ V} \leq V_{OUT} \leq V_{REG} - 1.2\text{ V}$	450	1000		
				$-40^\circ\text{C} \leq T_J \leq 125^\circ\text{C}$, $1\text{ V} \leq V_{OUT} \leq V_{REG} - 1.3\text{ V}$	200			
		$R_L = 2\text{ k}\Omega$	LM3411A 3.3-V	$T_J = 25^\circ\text{C}$, $1\text{ V} \leq V_{OUT} \leq V_{REG} - 1.2\text{ V}$	1500	3500		
				$-40^\circ\text{C} \leq T_J \leq 125^\circ\text{C}$, $1\text{ V} \leq V_{OUT} \leq V_{REG} - 1.3\text{ V}$	900			
			LM3411 3.3-V	$T_J = 25^\circ\text{C}$, $1\text{ V} \leq V_{OUT} \leq V_{REG} - 1.2\text{ V}$	1000	3500		
				$-40^\circ\text{C} \leq T_J \leq 125^\circ\text{C}$, $1\text{ V} \leq V_{OUT} \leq V_{REG} - 1.3\text{ V}$	700			
V_{SAT}	Output saturation ⁽⁴⁾	$V_{IN} = V_{REG} + 100\text{ mV}$, $I_{OUT} = 15\text{ mA}$	LM3411A 3.3-V	$T_J = 25^\circ\text{C}$		1	1.2	V
				$-40^\circ\text{C} \leq T_J \leq 125^\circ\text{C}$			1.3	
			LM3411 3.3-V	$T_J = 25^\circ\text{C}$		1	1.2	
				$-40^\circ\text{C} \leq T_J \leq 125^\circ\text{C}$			1.3	
I_L	Output leakage current	$V_{IN} = V_{REG} - 100\text{ mV}$, $V_{OUT} = 0\text{ V}$	LM3411A 3.3-V	$T_J = 25^\circ\text{C}$		0.1	0.5	μA
				$-40^\circ\text{C} \leq T_J \leq 125^\circ\text{C}$			1	
			LM3411 3.3-V	$T_J = 25^\circ\text{C}$		0.1	0.5	
				$-40^\circ\text{C} \leq T_J \leq 125^\circ\text{C}$			1	
R_f	Internal feedback resistor	LM3411A 3.3-V		39	52	65	k Ω	
		LM3411 3.3-V		39	52	65		
E_n	Output noise voltage	$I_{OUT} = 1\text{ mA}$, $10\text{ Hz} \leq f \leq 10\text{ kHz}$			50		μV_{RMS}	

(1) Limits are 100% production tested at 25°C . Limits over the operating temperature range are ensured through correlation using Statistical Quality Control (SQC) methods. The limits are used to calculate TI's Averaging Outgoing Level (AOQL).

(2) Typical numbers are at 25°C and represent the most likely parametric norm.

(3) Actual test is done using equivalent current sink instead of a resistor load.

(4) $V_{SAT} = V_{IN} - V_{OUT}$, when the voltage at the IN pin is forced 100 mV above the nominal regulating voltage (V_{REG}).

6.6 Electrical Characteristics: 5-V Version

 Specifications are for $T_J = 25^\circ\text{C}$, $V_{IN} = V_{REG}$, and $V_{OUT} = 1.5\text{ V}$ (unless otherwise noted).

PARAMETER		TEST CONDITIONS		MIN ⁽¹⁾	TYP ⁽²⁾	MAX ⁽¹⁾	UNIT	
V_{REG}	Regulation voltage	$I_{OUT} = 5\text{ mA}$	LM3411A 5-V	$T_J = 25^\circ\text{C}$	4.975	5	5.025	V
				$-40^\circ\text{C} \leq T_J \leq 125^\circ\text{C}$	4.95		5.05	
			LM3411 5-V	$T_J = 25^\circ\text{C}$	4.95	5	5.05	
				$-40^\circ\text{C} \leq T_J \leq 125^\circ\text{C}$	4.9		5.1	
	Regulation voltage tolerance	$I_{OUT} = 5\text{ mA}$	LM3411A 5-V	$T_J = 25^\circ\text{C}$			$\pm 0.5\%$	
				$-40^\circ\text{C} \leq T_J \leq 125^\circ\text{C}$			$\pm 1\%$	
		LM3411 5-V	$T_J = 25^\circ\text{C}$			$\pm 1\%$		
			$-40^\circ\text{C} \leq T_J \leq 125^\circ\text{C}$			$\pm 2\%$		
I_q	Quiescent current	$I_{OUT} = 5\text{ mA}$	LM3411A 5-V	$T_J = 25^\circ\text{C}$		85	110	μA
				$-40^\circ\text{C} \leq T_J \leq 125^\circ\text{C}$			115	
			LM3411 5-V	$T_J = 25^\circ\text{C}$		85	125	
				$-40^\circ\text{C} \leq T_J \leq 125^\circ\text{C}$			150	
G_m	Transconductance $\Delta I_{OUT}/\Delta V_{REG}$	$20\ \mu\text{A} \leq I_{OUT} \leq 1\text{ mA}$	LM3411A 5-V	$T_J = 25^\circ\text{C}$	1.5	3.3	mA/mV	
				$-40^\circ\text{C} \leq T_J \leq 125^\circ\text{C}$	0.75			
			LM3411 5-V	$T_J = 25^\circ\text{C}$	1	3.3		
				$-40^\circ\text{C} \leq T_J \leq 125^\circ\text{C}$	0.5			
		$1\text{ mA} \leq I_{OUT} \leq 15\text{ mA}$	LM3411A 5-V	$T_J = 25^\circ\text{C}$	3.3	6		
			LM3411 5-V	$T_J = 25^\circ\text{C}$	2.5	6		
			$-40^\circ\text{C} \leq T_J \leq 125^\circ\text{C}$	1.7				
A_V	Voltage gain $\Delta V_{OUT}/\Delta V_{REG}$	$R_L = 250\ \Omega^{(3)}$	LM3411A 5-V	$T_J = 25^\circ\text{C}$, $1\text{ V} \leq V_{OUT} \leq V_{REG} - 1.2\text{ V}$	750	1000	V/V	
				$-40^\circ\text{C} \leq T_J \leq 125^\circ\text{C}$, $1\text{ V} \leq V_{OUT} \leq V_{REG} - 1.3\text{ V}$	350			
			LM3411 5-V	$T_J = 25^\circ\text{C}$, $1\text{ V} \leq V_{OUT} \leq V_{REG} - 1.2\text{ V}$	650	1000		
				$-40^\circ\text{C} \leq T_J \leq 125^\circ\text{C}$, $1\text{ V} \leq V_{OUT} \leq V_{REG} - 1.3\text{ V}$	300			
		$R_L = 2\text{ k}\Omega$	LM3411A 5-V	$T_J = 25^\circ\text{C}$, $1\text{ V} \leq V_{OUT} \leq V_{REG} - 1.2\text{ V}$	1500	3500		
				$-40^\circ\text{C} \leq T_J \leq 125^\circ\text{C}$, $1\text{ V} \leq V_{OUT} \leq V_{REG} - 1.3\text{ V}$	900			
			LM3411 5-V	$T_J = 25^\circ\text{C}$, $1\text{ V} \leq V_{OUT} \leq V_{REG} - 1.2\text{ V}$	1000	3500		
				$-40^\circ\text{C} \leq T_J \leq 125^\circ\text{C}$, $1\text{ V} \leq V_{OUT} \leq V_{REG} - 1.3\text{ V}$	700			
V_{SAT}	Output saturation ⁽⁴⁾	$V_{IN} = V_{REG} + 100\text{ mV}$, $I_{OUT} = 15\text{ mA}$	LM3411A 5-V	$T_J = 25^\circ\text{C}$		1	1.2	V
				$-40^\circ\text{C} \leq T_J \leq 125^\circ\text{C}$			1.3	
			LM3411 5-V	$T_J = 25^\circ\text{C}$		1	1.2	
				$-40^\circ\text{C} \leq T_J \leq 125^\circ\text{C}$			1.3	
I_L	Output leakage current	$V_{IN} = V_{REG} - 100\text{ mV}$, $V_{OUT} = 0\text{ V}$	LM3411A 5-V	$T_J = 25^\circ\text{C}$		0.1	0.5	μA
				$-40^\circ\text{C} \leq T_J \leq 125^\circ\text{C}$			1	
			LM3411 5-V	$T_J = 25^\circ\text{C}$		0.1	0.5	
				$-40^\circ\text{C} \leq T_J \leq 125^\circ\text{C}$			1	
R_f	Internal feedback resistor	LM3411A 5-V		70	94	118	$\text{k}\Omega$	
		LM3411 5-V		70	94	118		
E_n	Output noise voltage	$I_{OUT} = 1\text{ mA}$, $10\text{ Hz} \leq f \leq 10\text{ kHz}$		80			μV_{RMS}	

(1) Limits are 100% production tested at 25°C . Limits over the operating temperature range are ensured through correlation using Statistical Quality Control (SQC) methods. The limits are used to calculate TI's Averaging Outgoing Level (AOQL).

(2) Typical numbers are at 25°C and represent the most likely parametric norm.

(3) Actual test is done using equivalent current sink instead of a resistor load.

(4) $V_{SAT} = V_{IN} - V_{OUT}$, when the voltage at the IN pin is forced 100 mV above the nominal regulating voltage (V_{REG}).

6.7 Typical Characteristics

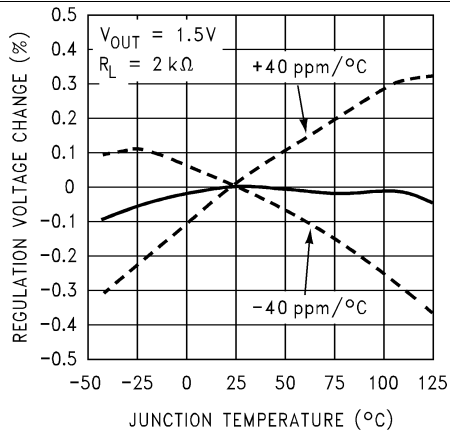

Figure 1. Normalized Temperature Drift

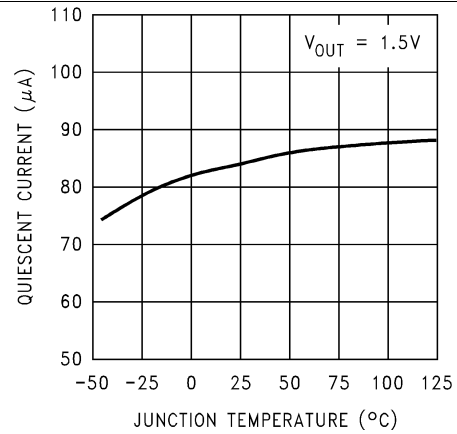

Figure 2. Quiescent Current

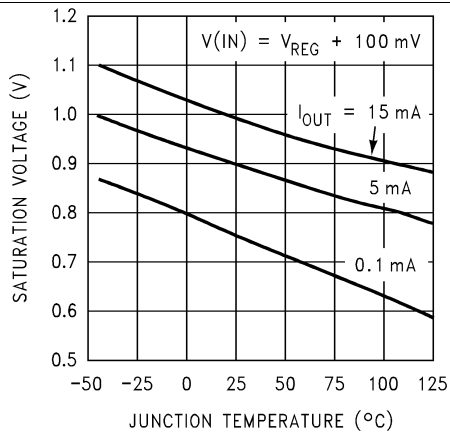

Figure 3. Output Saturation Voltage, V_{SAT}

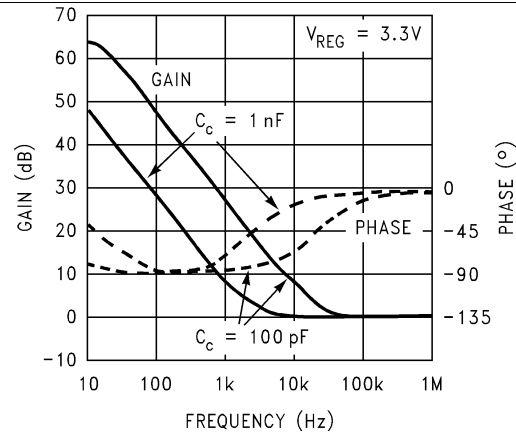

Figure 4. Bode Plot

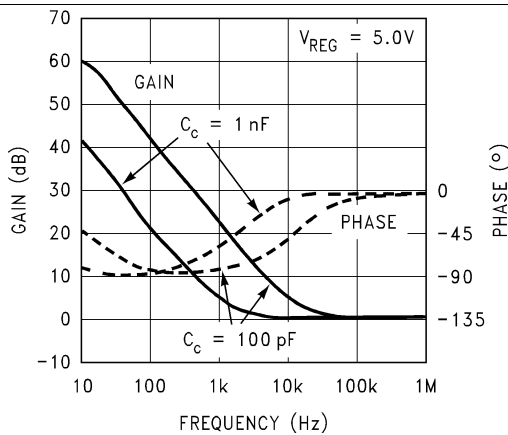

Figure 5. Bode Plot

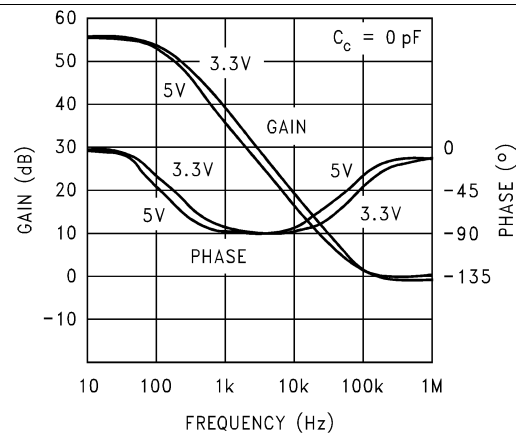

Figure 6. Bode Plot

Typical Characteristics (continued)

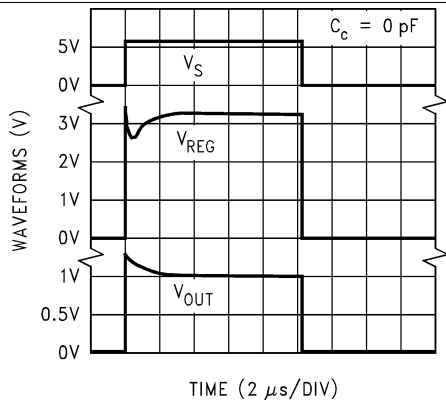

Figure 7. Response Time for 3.3-V Version ($C_C = 0$ pF)

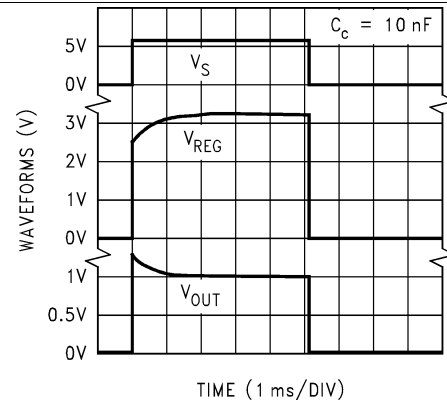

Figure 8. Response Time for 3.3-V Version ($C_C = 10$ nF)

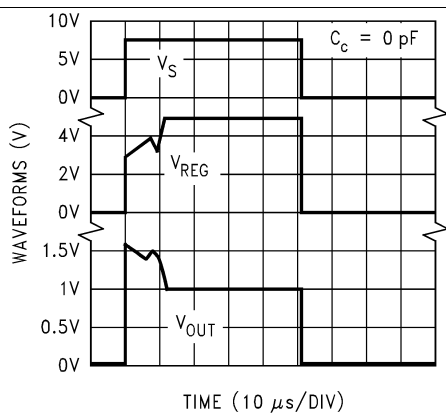

Figure 9. Response Time for 5-V Version ($C_C = 0$ pF)

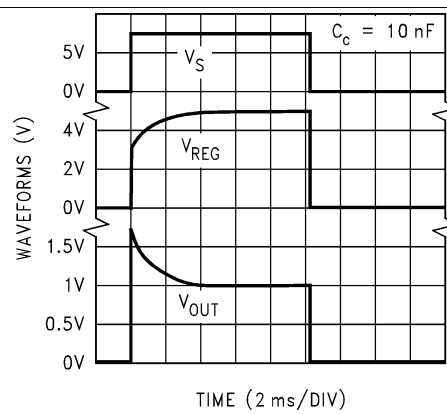

Figure 10. Response Time for 5-V Version ($C_C = 10$ nF)

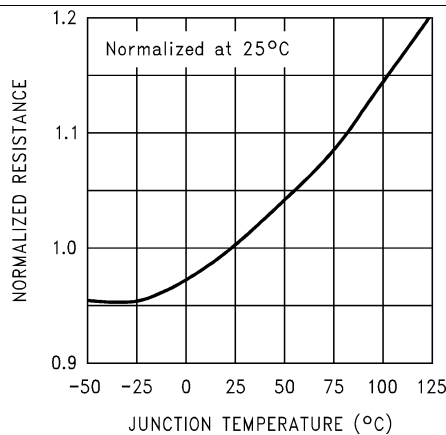

Figure 11. Tempco of Internal Feedback Resistor (R_f)

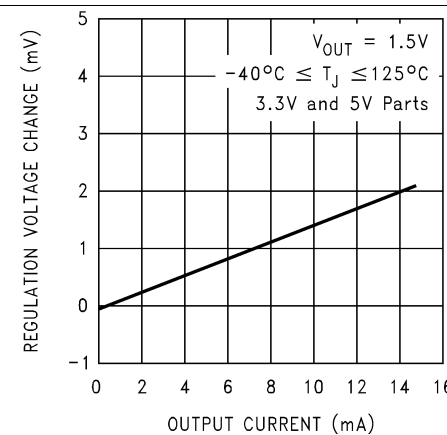
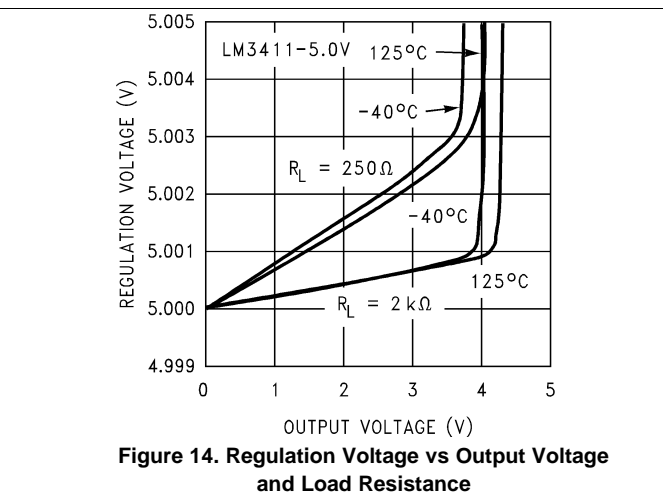
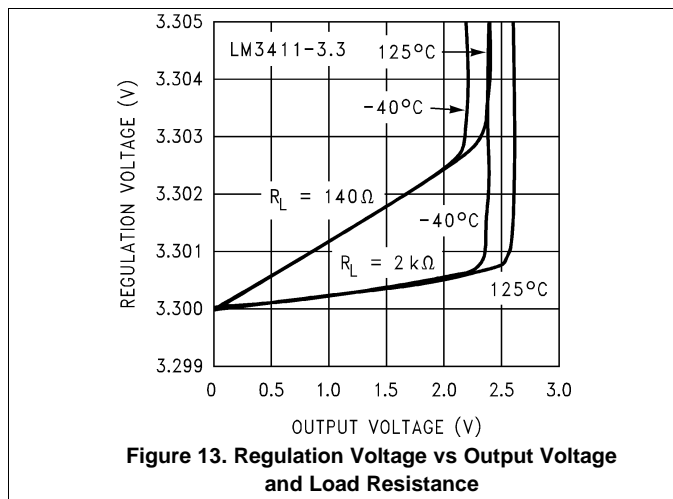

Figure 12. Regulation Voltage Change vs Output Current

Typical Characteristics (continued)



7 Parameter Measurement Information

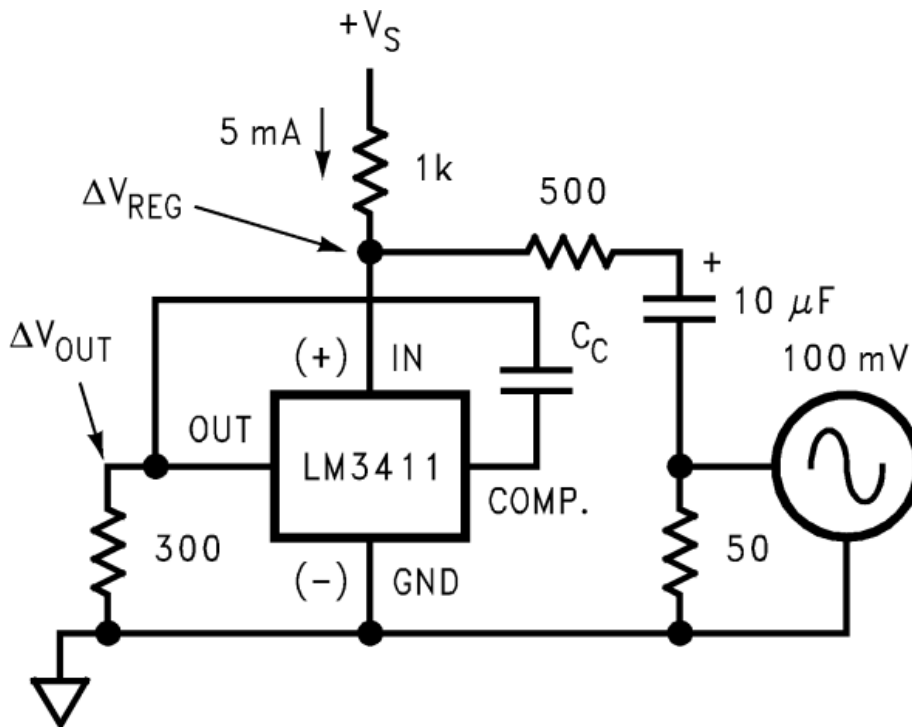

Figure 15. Circuit Used for Bode Plots

Parameter Measurement Information (continued)

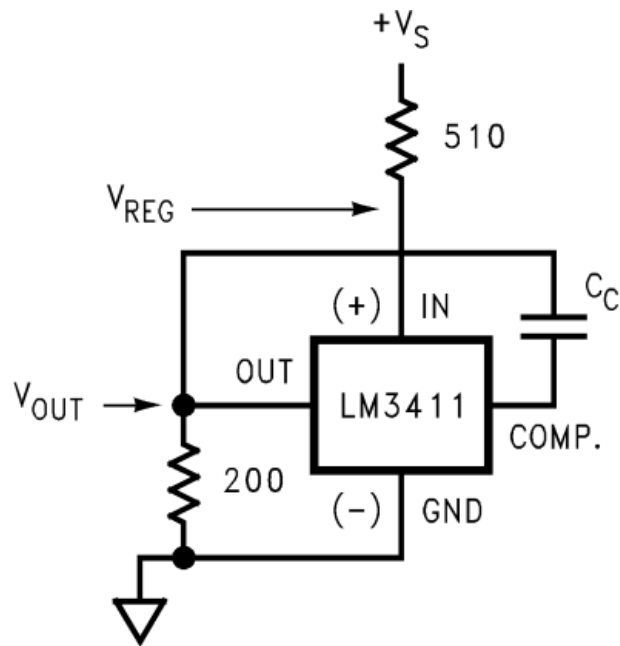

Figure 16. Circuit Used for Response Time

8 Detailed Description

8.1 Overview

The LM3411 is a shunt regulator specifically designed to be the reference and control section in an overall feedback loop of a regulated power supply. The regulated output voltage is sensed between the IN pin and GROUND pin of the LM3411. If the voltage at the IN pin is less than the LM3411 regulating voltage (V_{REG}), the OUT pin sources no current. As the voltage at the IN pin approaches the V_{REG} voltage, the OUT pin begins sourcing current. This current is then used to drive a feedback device, (optocoupler) or a power device (linear regulator, switching regulator, and so forth) which serves the output voltage to be the same value as V_{REG} .

In some applications (even under normal operating conditions), the voltage on the IN pin can be forced above the V_{REG} voltage. In these instances, the maximum voltage applied to the IN pin should not exceed 20 V. In addition, an external resistor may be required on the OUT pin to limit the maximum current to 20 mA.

8.2 Functional Block Diagrams

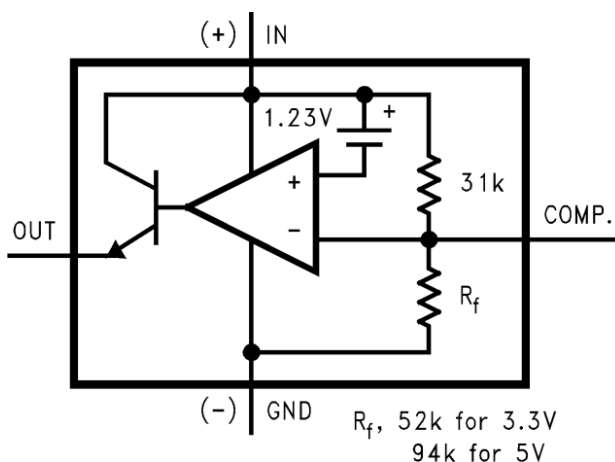

Copyright © 2016, Texas Instruments Incorporated

Figure 17. LM3411 Functional Diagram

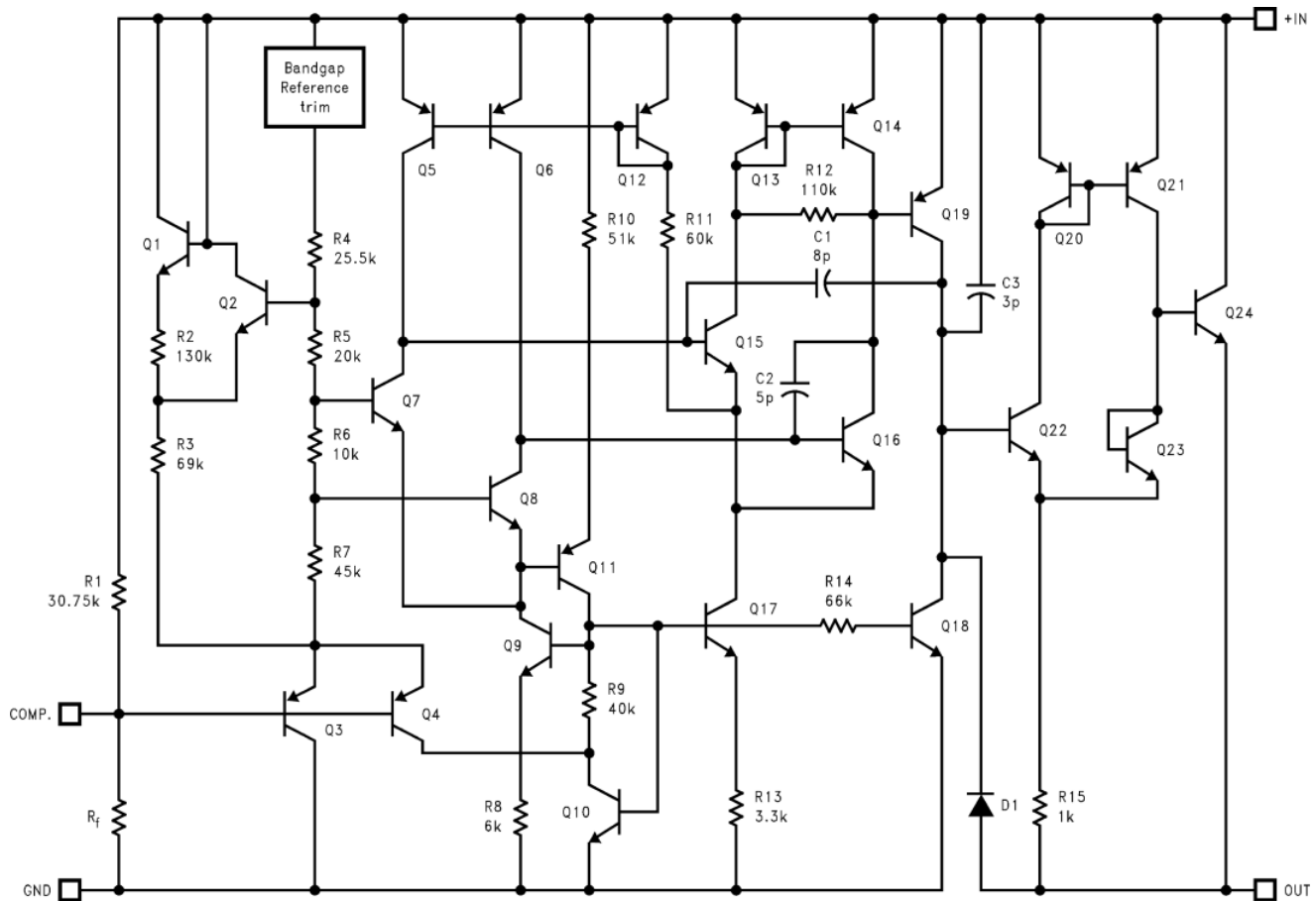
Functional Block Diagrams (continued)

Copyright © 2016, Texas Instruments Incorporated

Figure 18. Detailed Schematic
8.3 Feature Description

The LM3411 devices contain an internal operational amplifier, precision reference, feedback resistor divider, and a bi-polar transistor suitable for driving an optocoupler. The divider resistor is sized such that the system will regulate the +IN pin to either 3.3 V or 5 V depending on the device version used. By connecting a feedback network from the OUT pin to the COMP pin, local compensation is implemented to stabilize the system.

8.4 Device Functional Modes

The primary mode of operation for the LM3411 is as a shunt regulator. In addition the device has robust overcurrent protection. These features make it applicable to a wide range of applications ranging from isolated feedback control to traditional shunt regulation.

9 Application and Implementation

NOTE

Information in the following applications sections is not part of the TI component specification, and TI does not warrant its accuracy or completeness. TI's customers are responsible for determining suitability of components for their purposes. Customers should validate and test their design implementation to confirm system functionality.

9.1 Application Information

The LM3411 is a high-efficiency shunt regulator optimized for driving an opto-coupler in an isolated feedback system. This enables accurate regulation of the output voltage as well as convenient drive to the opto-coupler in a small SOT-23 package. In addition to isolated feedback systems the LM3411 is also applicable to a wide variety of linear regulator applications.

9.2 Typical Applications

9.2.1 LM3411 Typical Application

Figure 19 shows a typical use case for the LM3411. Here, the device is used as a precision shunt regulator to control the output voltage of a switching power supply. The LM3411 provides the functionality necessary to drive the external opto-coupler, an on-board reference necessary for precision control of the DC output voltage, and an on-board operational amplifier for providing the necessary compensation to optimize the transient performance of the system.

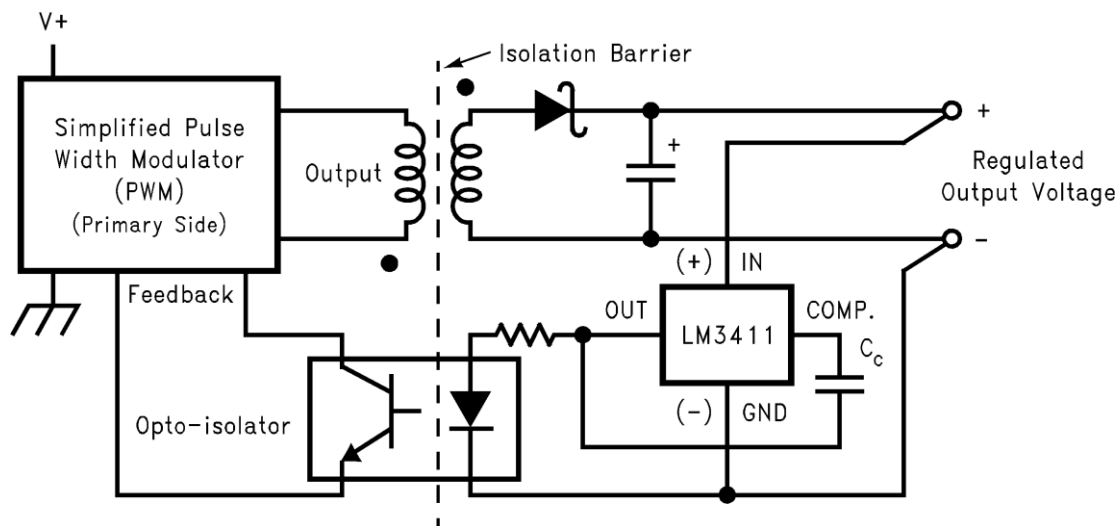

Copyright © 2016, Texas Instruments Incorporated

Figure 19. LM3411 Typical Application Schematic

9.2.1.1 Design Requirements

The following sections provide a variety of application level design examples. See the following for the basic requirements.

- Isolated flyback converter example is 5 V with 250 mA.
- Isolated flyback converter example is 3.3 V or 5 V with 1.5 A.
- Buck converter example is 5 V with 1 A.
- Flyback converter example is $V_{IN} = -20\text{ V to } -10\text{ V}$ and $V_{OUT} = -5\text{ V}$ with 1 A.
- Low dropout linear regulator example is 5 V with 1 A.

Typical Applications (continued)

- Low dropout linear regulator example is 3.3 V and 0.5 A.
- Precision positive voltage regulator with accurate current limit is $V_{IN} = 9\text{ V to }20\text{ V}$ and $V_{OUT} = 5\text{ V}$.
- Negative voltage regulator example is $V_{IN} = -8\text{ V to }-20\text{ V}$ and $V_{OUT} = -5\text{ V}$.
- 250-mA shunt regulator example is $V_{OUT} = 5\text{ V}$.

9.2.1.2 Detailed Design Procedure

9.2.1.2.1 Compensation

The inverting input of the error amplifier is brought out to allow overall closed-loop compensation. In many of the applications circuits shown in the subsequent sections, compensation is provided by a single capacitor connected from the compensation pin to the out pin of the LM3411. The capacitor values shown in the schematics accompanying these sections are adequate under most conditions, but they can be increased or decreased depending on the desired loop response. Applying a load pulse to the output of a regulator circuit and observing the resultant output voltage response is a easy method of determining the stability of the control loop. Analyzing more complex feedback loops requires additional information.

The formula for AC gain at a frequency (f) as in [Equation 1](#).

$$\text{Gain (f)} = 1 + \frac{Z_f(f)}{R_f}$$

$$\text{where } Z_f(f) = \frac{1}{j \times 2\pi \times f \times C}$$

where

- $R_f \approx 52\text{ k}\Omega$ for the 3.3-V part
- $R_f \approx 94\text{ k}\Omega$ for the 5-V part

(1)

The resistor (R_f) in the formula is an internal resistor located on the die. Since this resistor value will affect the phase margin, the worst case maximum and minimum values are important when analyzing closed loop stability. The minimum and maximum room temperature values of this resistor are specified in [Electrical Characteristics: 3.3-V Version](#) of this data sheet, and [Figure 11](#) shows the temperature coefficient from [Typical Characteristics](#). In the applications shown in the subsequent sections, the worst case phase margin occurs with minimum values of R_f .

9.2.1.2.2 Test Circuit

The test circuit shown in [Figure 20](#) can be used to measure and verify various LM3411 parameters. Test conditions are set by forcing the appropriate voltage at the V_{OUT} . Set test point and selecting the appropriate R_L or I_{OUT} as specified in [Electrical Characteristics](#). Use a DVM at the *measure* test points to read the data.

Typical Applications (continued)

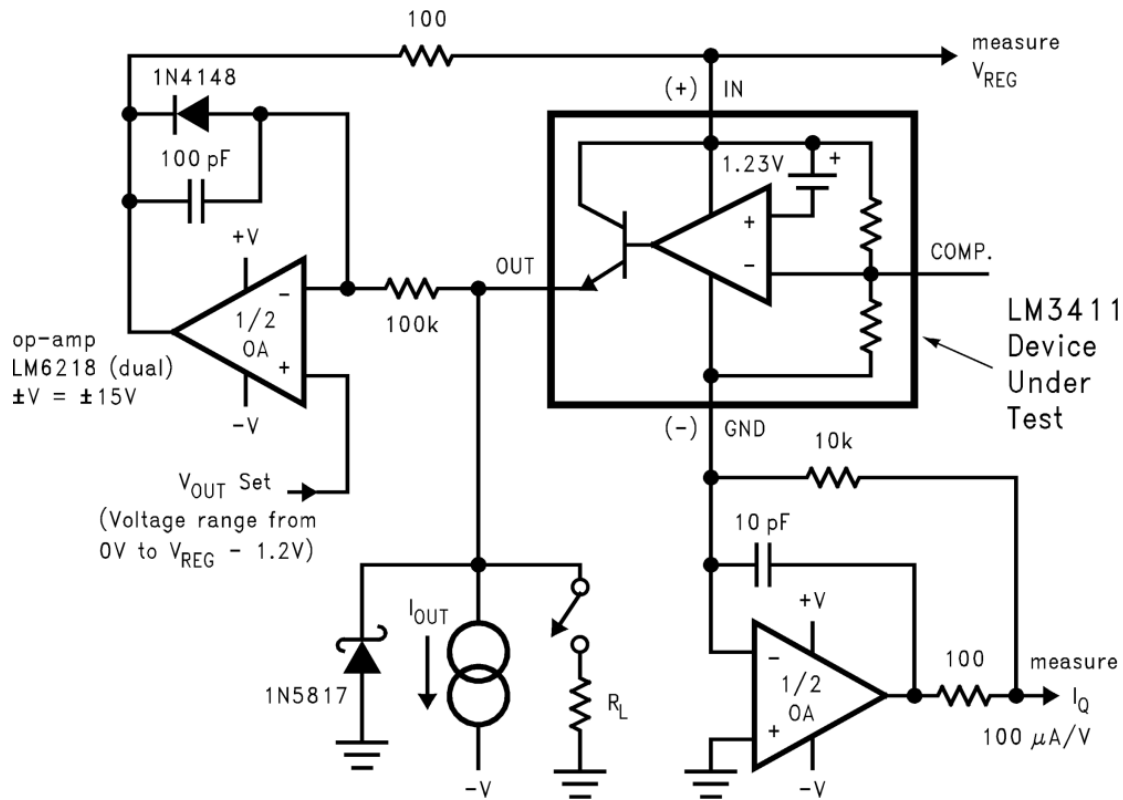

Figure 20. LM3411 Test Circuit

9.2.1.3 Application Curves

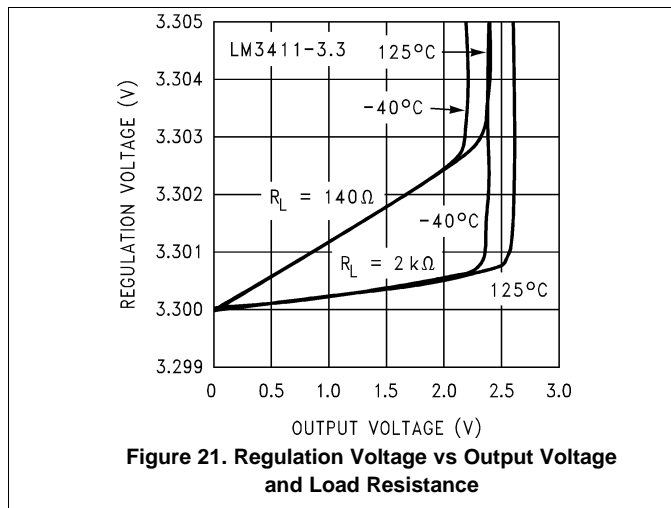

Figure 21. Regulation Voltage vs Output Voltage and Load Resistance

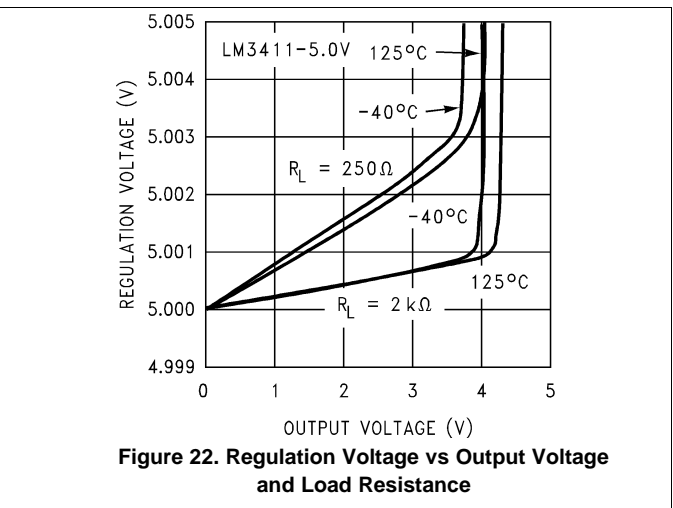
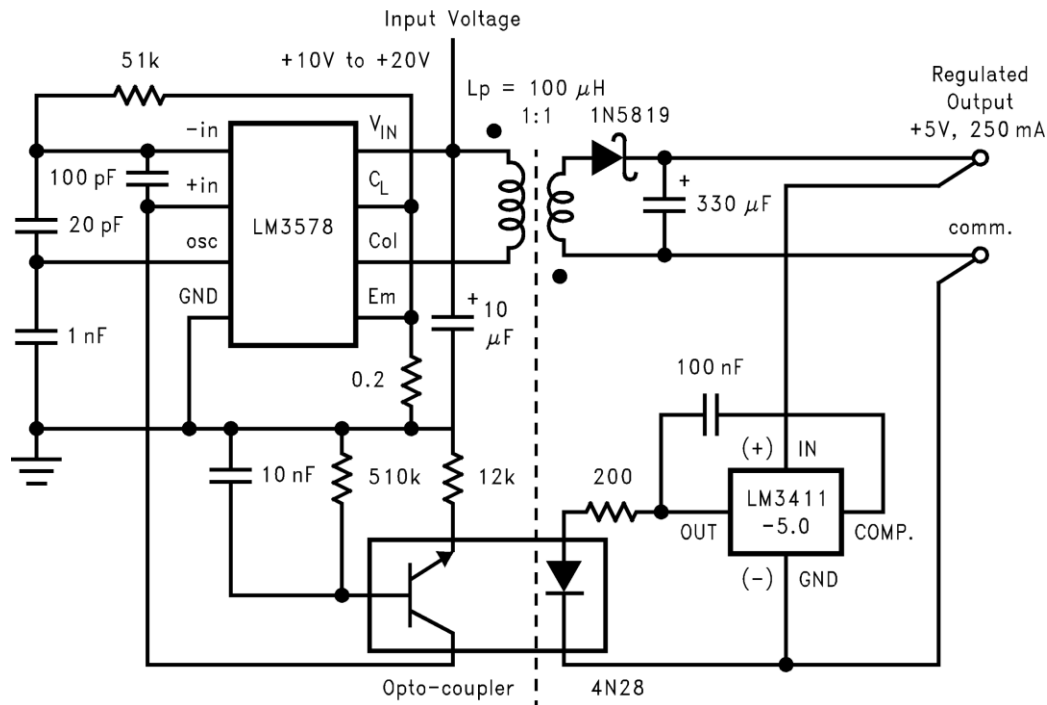

Figure 22. Regulation Voltage vs Output Voltage and Load Resistance

Typical Applications (continued)
9.2.2 Isolated 250-mA Flyback Switching Regulator

Copyright © 2016, Texas Instruments Incorporated

Figure 23. Isolated 250-mA Flyback Switching Regulator Schematic
9.2.2.1 Design Requirements

The design requirements for this isolated flyback converter example are 5 V with 250 mA.

9.2.2.2 Detailed Design Procedure

The LM3411 regulator or driver provides the reference and feedback drive functions in a regulated power supply. It can also be used together with many different types of regulators, (both linear and switching) as well as other power semiconductor devices to add precision and improve regulation specifications. Output voltage tolerances better than 0.5% are possible without using trim pots or precision resistors.

One of the main applications of the LM3411 is to drive an opto-isolator to provide feedback signal isolation in a switching regulator circuit. For low current applications (up to 250 mA), see [Figure 23](#) for a circuit that provides good regulation and complete input and output electrical isolation.

For an input voltage of 15 V, this circuit can provide an output of either 3.3 V or 5 V with a load current up to 250 mA with excellent regulation characteristics. With the part values shown, this circuit operates at 80 kHz, and can be synchronized to a clock or an additional LM3578. See LM3578A's data sheet ([SNVS767](#)) for additional information.

Typical Applications (continued)

9.2.3 Isolated 1.5-A Flyback Switching Regulator

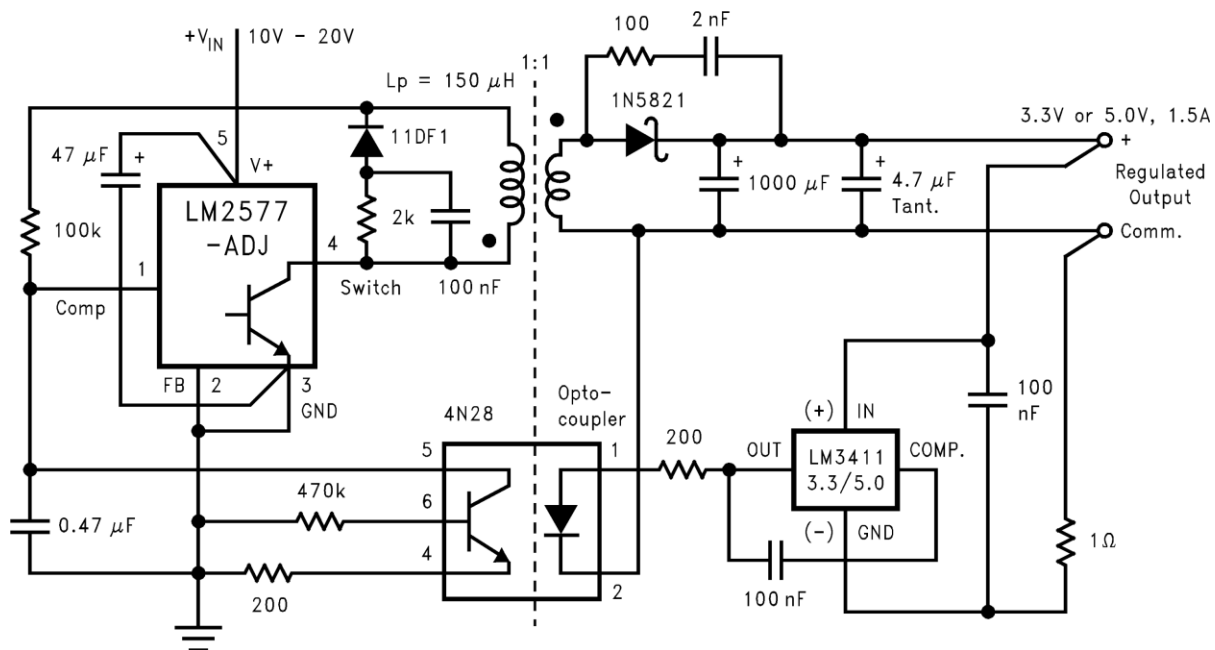

Copyright © 2016, Texas Instruments Incorporated

Figure 24. Isolated 1.5-A Flyback Switching Regulator Using a LM2577

9.2.3.1 Design Requirements

The design requirements for this isolated flyback converter example are 3.3 V or 5 V with 1.5 A.

9.2.3.2 Detailed Design Procedure

An isolated DC-DC flyback converter capable of higher output current is shown in [Figure 24](#). This circuit uses the LM2577 SIMPLE SWITCHER voltage regulator for the Pulse Width Modulation (PWM), power switch, and protection functions, while the LM3411 provides the voltage reference, gain, and opto-coupler drive functions. In this circuit, the reference and error amplifier in the LM2577 are not used (note that the feedback pin is grounded). The gain is provided by the LM3411. Since the voltage reference is located on the secondary side of the transformer, this circuit provides very good regulation specifications.

The output of a switching regulator typically will contain a small ripple voltage at the switching frequency and may also contain voltage transients. These transient voltage spikes can be sensed by the LM3411 and could give an incorrect regulation voltage. An RC filter consisting of a 1-Ω resistor and a 100-nF capacitor will filter these transients and minimize this problem. The 1-Ω resistor should be located on the ground side of the LM3411, and the capacitor should be physically located near the package.

Typical Applications (continued)

9.2.4 Precision 1-A Buck Regulator

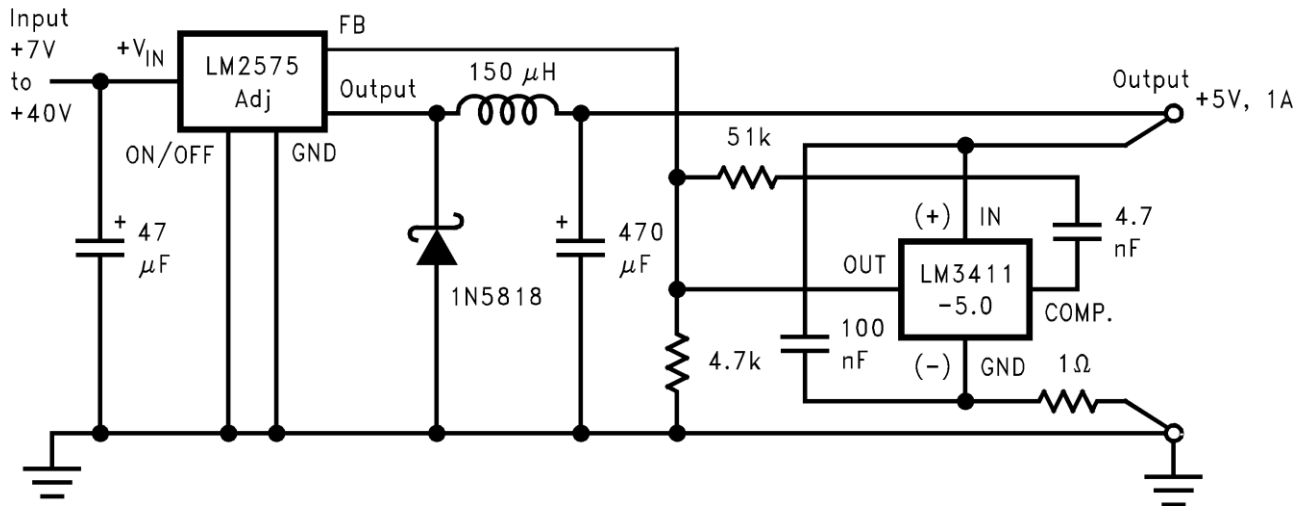

Copyright © 2016, Texas Instruments Incorporated

Figure 25. Precision 1-A Buck Regulator Schematic

9.2.4.1 Design Requirements

The design requirements for this precision buck converter example are 5 V with 1 A.

9.2.4.2 Detailed Design Procedure

Improved output voltage tolerance and regulation specifications are possible by combining the LM3411A with one of the SIMPLE SWITCHER buck regulator IC's, such as the LM2574, LM2575, or LM2576. Figure 25 shows a circuit capable of providing a 5-V, ±0.5% output (1% over the operating temperature range) without using any trim-pots or precision resistors. Typical line regulation numbers are a 1 mV change on the output for a 8 V to 18 V change on the input, and load regulation of 1 mV with a load change from 100 mA to 1 A.

9.2.5 Negative Input, Negative or Positive Output Flyback Regulator

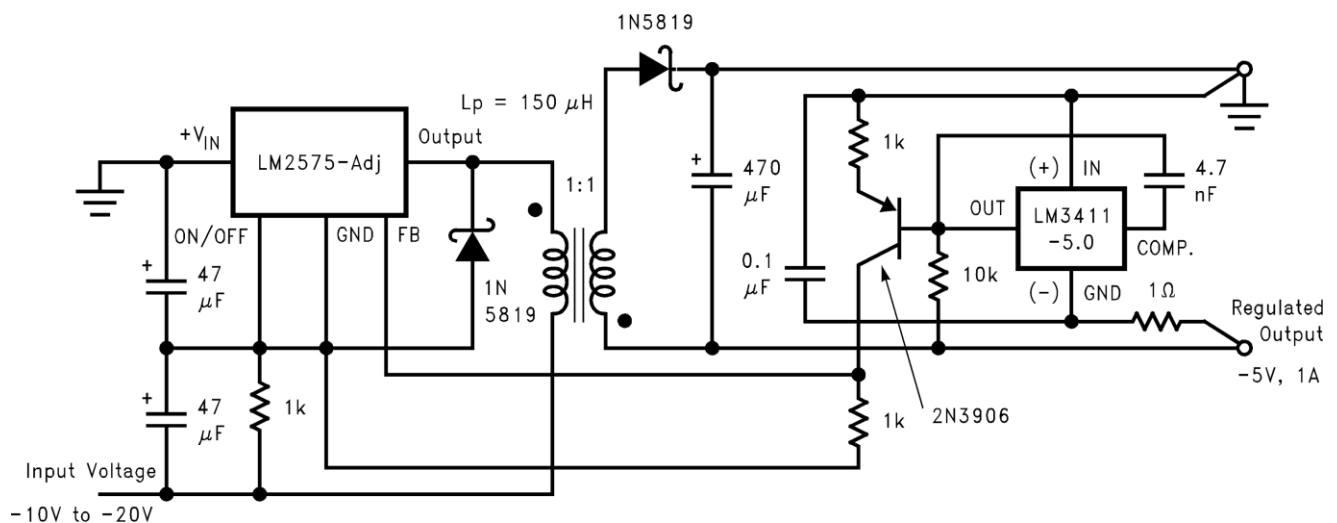

Copyright © 2016, Texas Instruments Incorporated

Figure 26. Negative Input, Negative or Positive Output Flyback Regulator Schematic

Typical Applications (continued)

9.2.5.1 Design Requirements

The design requirements for this flyback converter example are $V_{IN} = -20\text{ V}$ to -10 V and $V_{OUT} = -5\text{ V}$ with 1 A.

9.2.5.2 Detailed Design Procedure

A DC-DC flyback converter that accepts a negative input voltage, and delivers either a positive or negative output is shown in Figure 26. The circuit uses a buck regulator (such as the LM2574, LM2575, or LM2576, depending on how much output current is needed) operating in a flyback configuration. The LM3411 provides the reference and the required level shifting circuitry needed to make the circuit work correctly.

A unique feature of this circuit is the ability to ground either the high or low side of the output, thus generating either a negative or a positive output voltage. Although no isolation is provided, with the addition of an opto-isolator and related components, this circuit could provide input/output isolation.

Combining a LM3411A 5-V version with a 1-A low dropout linear regulator results in a $5\text{ V} \pm 0.5\%$ (1% over the operating temperature range) regulator with excellent regulation specifications, with no trimming or 1% resistors needed.

An added benefit of this circuit (and also true of many of the other circuits shown) is the high-side and low-side remote output voltage sensing feature. Sensing the output voltage at the load eliminates the voltage drops associated with wire resistance, thus providing near perfect load regulation.

9.2.6 Precision 5-V, 1-A Low Dropout Regulator

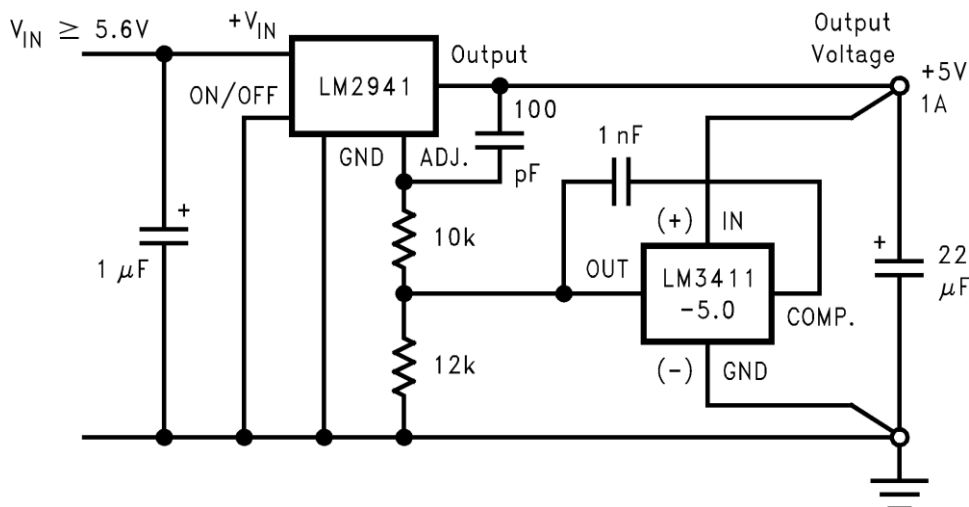

Copyright © 2016, Texas Instruments Incorporated

Figure 27. Precision 5-V, 1-A Low Dropout Regulator

9.2.6.1 Design Requirements

The design requirements for this precision low dropout linear regulator example are 5 V with 1 A.

9.2.6.2 Detailed Design Procedure

Figure 27 shows a 5-V, 1-A regulator circuit featuring low dropout, very good regulation specifications, self-protection features, and allows output voltage sensing. The regulator used is a LM2941 adjustable low dropout positive regulator, which also features an ON/OFF pin to provide a shutdown feature.

Typical Applications (continued)

9.2.7 3.3-V, 0.5-A Low Dropout Regulator

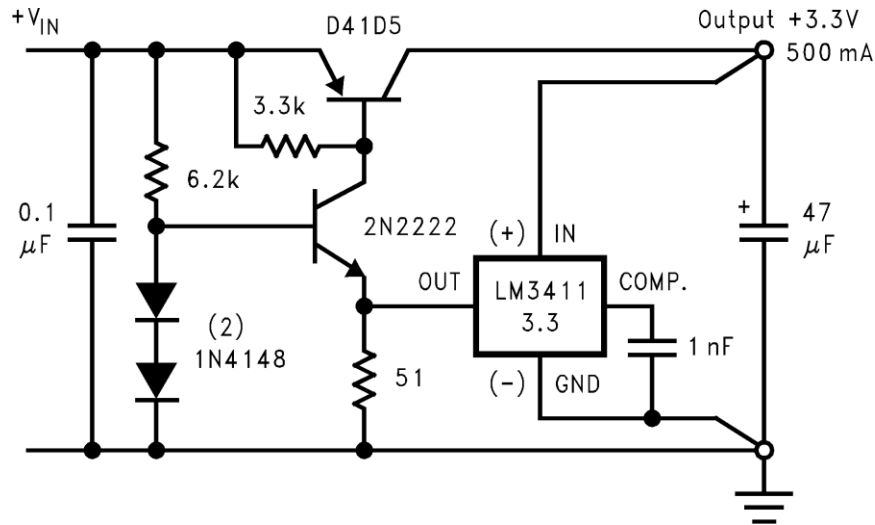

Copyright © 2016, Texas Instruments Incorporated

Figure 28. 3.3-V, 0.5-A Low Dropout Regulator Schematic

9.2.7.1 Design Requirements

The design requirements for this low dropout linear regulator example are 3.3 V and 0.5 A.

9.2.7.2 Detailed Design Procedure

The circuit in Figure 28 shows a 3.3-V low dropout regulator using the LM3411-3.3 and several discrete components. This circuit is capable of excellent performance with both the dropout voltage and the ground pin current specifications improved over the LM2941 and LM3411 circuit.

9.2.8 Precision Positive Voltage Regulator With Accurate Current Limit

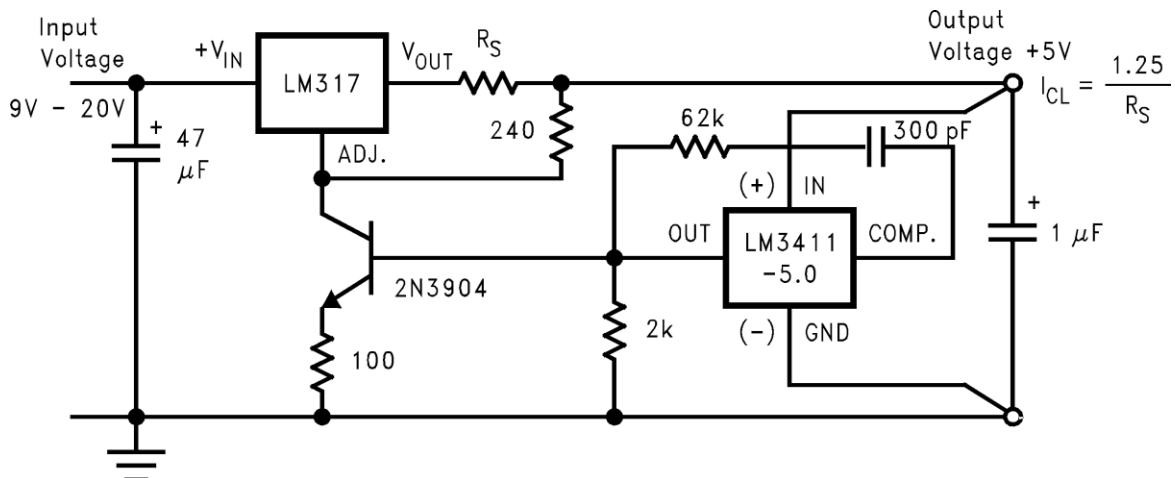

Copyright © 2016, Texas Instruments Incorporated

Figure 29. Precision Positive Voltage Regulator With Accurate Current Limit Schematic

Typical Applications (continued)

9.2.8.1 Design Requirements

The design requirements for this precision positive voltage regulator with accurate current limit are $V_{IN} = 9\text{ V}$ to 20 V and $V_{OUT} = 5\text{ V}$.

9.2.8.2 Detailed Design Procedure

The standard LM317 three terminal adjustable regulator circuit can greatly benefit by adding a LM3411. Performance is increased and features are added. Figure 29 shows a circuit capable of providing further improved line and load regulation, lower temperature drift, and full remote output voltage sensing on both the high and low side. In addition, a precise current limit or constant current feature is simple to add.

Current limit protection in most IC regulators is mainly to protect the IC from gross overcurrent conditions which could otherwise fuse bonding wires or blow IC metalization, therefore not much precision is needed for the actual current limit values. Current limit tolerances can sometimes vary from $\pm 10\%$ to as high as $+300\%$ over manufacturing and temperature variations. Often critical circuitry requires a much tighter control over the amount of current the power supply can deliver. For example, a power supply may be needed that can deliver 100% of its design current, but can still limit the maximum current to 110% to protect critical circuitry from high current fault conditions.

The circuit in Figure 29 can provide a current limit accuracy that is better than $\pm 4\%$, over all possible variations, in addition to having excellent line, load, and temperature specifications.

9.2.9 Precision Negative Voltage Regulator

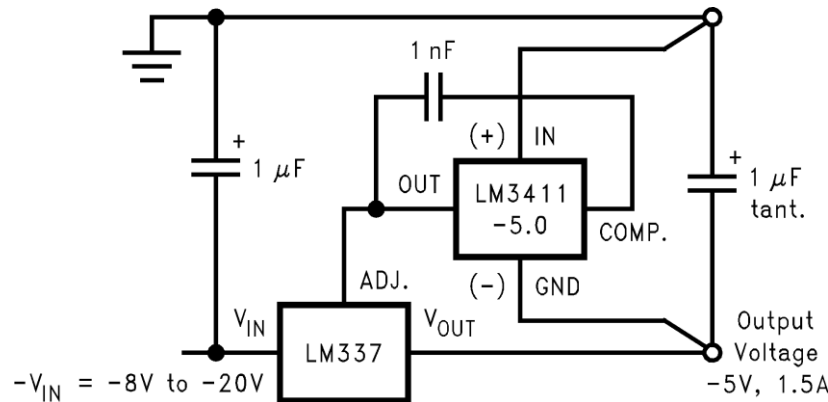

Copyright © 2016, Texas Instruments Incorporated

Figure 30. Precision Negative Voltage Regulator Schematic

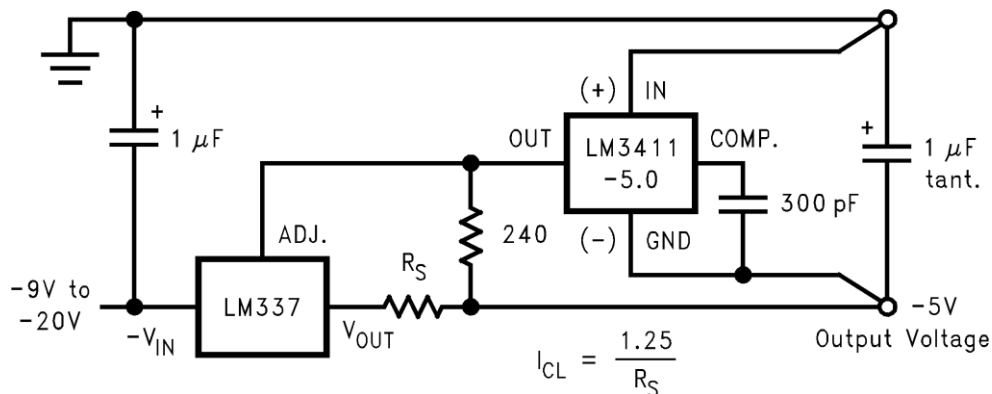

Copyright © 2016, Texas Instruments Incorporated

Figure 31. Precision Negative Voltage Regulator With Accurate Current Limit

Typical Applications (continued)

9.2.9.1 Design Requirements

The design requirements for this negative voltage regulator example are $V_{IN} = -8\text{ V to } -20\text{ V}$ and $V_{OUT} = -5\text{ V}$.

9.2.9.2 Detailed Design Procedure

Like the positive regulators, the performance of negative adjustable regulators can also be improved by adding the LM3411. Output voltages of either 3.3 V or 5 V at currents up to 1.5 A (3 A when using a LM333) are possible. Adding two resistors to the circuit in Figure 30 adds the precision current limit feature as shown in Figure 31. Current limit tolerances of $\pm 4\%$ over manufacturing and temperature variations are possible with this circuit.

9.2.10 4.7-V Power ON Detector With Hysteresis

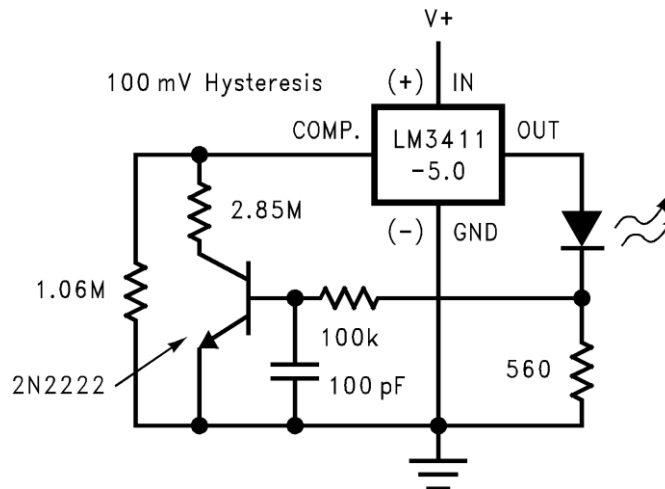

Copyright © 2016, Texas Instruments Incorporated

Figure 32. 4.7-V Power ON Detector With Hysteresis Schematic

9.2.10.1 Detailed Design Procedure

Figure 32 shows a simple 5-V supply monitor circuit. Using the LM3411's voltage reference, operational amplifier (as a comparator) and output driver, this circuit provides a LED indication of the presence of the 5-V supply.

9.2.11 $\pm 50\text{-mV}$ External Trim

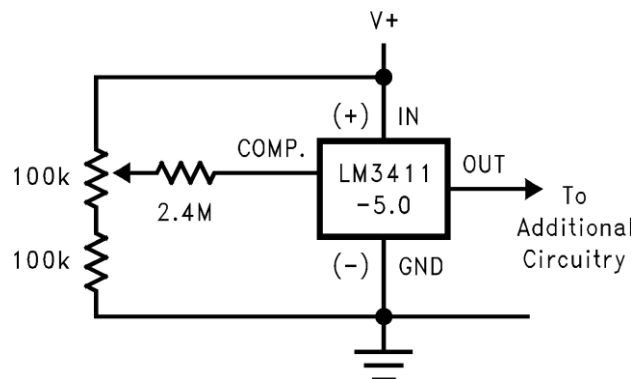

Copyright © 2016, Texas Instruments Incorporated

Figure 33. $\pm 50\text{-mV}$ External Trim Schematic

Typical Applications (continued)

9.2.11.1 Detailed Design Procedure

The LM3411 initial room temperature tolerance is $\pm 1\%$ and $\pm 0.5\%$ for the A grade part. If a tighter tolerance is needed, see [Figure 33](#) for a trim scheme that provides approximately $\pm 1\%$ adjustment range of the regulation voltage (V_{REG}).

9.2.12 250-mA Shunt Regulator

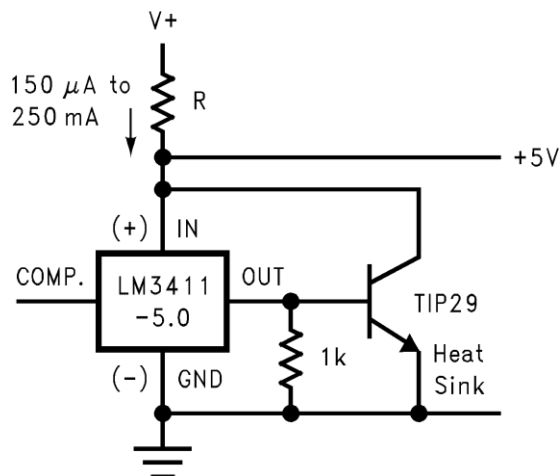

Copyright © 2016, Texas Instruments Incorporated

Figure 34. 250-mA Shunt Regulator Schematic

9.2.12.1 Design Requirements

The design requirement for this 250-mA shunt regulator example is $V_{OUT} = 5\text{ V}$.

9.2.12.2 Detailed Design Procedure

The LM3411 is ensured to drive a 15 mA load, but if more current is needed, a NPN boost transistor can be added. [Figure 34](#) shows a shunt regulator capable of providing excellent regulation over a very wide range of current.

9.2.13 Voltage Detector

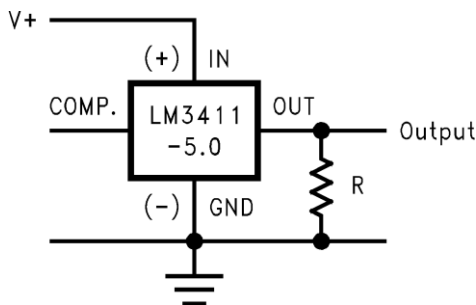

Copyright © 2016, Texas Instruments Incorporated

Figure 35. Voltage Detector Schematic

9.2.13.1 Detailed Design Procedure

Perhaps one of the simplest applications for the LM3411 is the voltage detector circuit shown in [Figure 35](#). The OUT pin is low when the input voltage is less than V_{REG} . When the V_{IN} pin rises above V_{REG} , the OUT pin is pulled high by the internal NPN output resistor.

Typical Applications (continued)

9.2.14 Overvoltage Crowbar

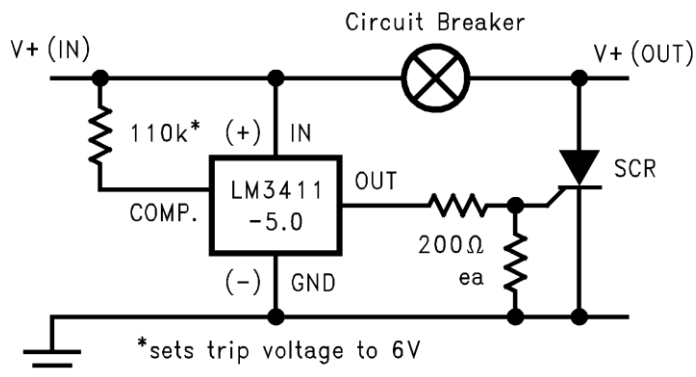

Copyright © 2016, Texas Instruments Incorporated

Figure 36. Overvoltage Crowbar Schematic

9.2.14.1 Detailed Design Procedure

Also an overvoltage detector, the crowbar circuit shown in [Figure 36](#) is normally located at the output of a power supply to protect the load from an overvoltage condition should the power supply fail with an input/output short.

10 Power Supply Recommendations

The output of a switching regulator typically will contain a small ripple voltage at the switching frequency and may also contain voltage transients. These transient voltage spikes can be sensed by the LM3411 and could give an incorrect regulation voltage. An RC filter consisting of a 1-Ω resistor and a 100-nF capacitor will filter these transients and minimize this problem.

11 Layout

11.1 Layout Guidelines

The 1-Ω resistor should be located on the ground side of the LM3411, and the 100-nF capacitor should be physically located near the package.

11.2 Layout Example

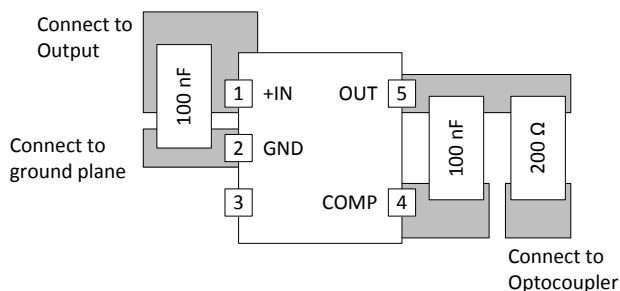

Figure 37. LM3411 Layout Schematic

12 Device and Documentation Support

12.1 Documentation Support

12.1.1 Related Documentation

For related documentation see the following:

- AN-450 *Surface Mounting Methods and Their Effect on Product Reliability*, [SNOA742](#)
- AN-1095 *Design of Isolated Converters Using Simple Switchers*, [SNVA005](#)
- AN-1305 *LM5030 Evaluation Board*, [SNVA078](#)
- *Versatility of the LM5030 PWM Push-Pull Controller*, [SNVA548](#)
- *LM2578A/LM3578A Switching Regulator*, [SNVS767](#)

12.2 Community Resources

The following links connect to TI community resources. Linked contents are provided "AS IS" by the respective contributors. They do not constitute TI specifications and do not necessarily reflect TI's views; see TI's [Terms of Use](#).

TI E2E™ Online Community *TI's Engineer-to-Engineer (E2E) Community*. Created to foster collaboration among engineers. At [e2e.ti.com](#), you can ask questions, share knowledge, explore ideas and help solve problems with fellow engineers.

Design Support *TI's Design Support* Quickly find helpful E2E forums along with design support tools and contact information for technical support.

12.3 Trademarks

E2E is a trademark of Texas Instruments.

All other trademarks are the property of their respective owners.

12.4 Electrostatic Discharge Caution



These devices have limited built-in ESD protection. The leads should be shorted together or the device placed in conductive foam during storage or handling to prevent electrostatic damage to the MOS gates.

12.5 Glossary

[SLYZ022](#) — *TI Glossary*.

This glossary lists and explains terms, acronyms, and definitions.

13 Mechanical, Packaging, and Orderable Information

The following pages include mechanical, packaging, and orderable information. This information is the most current data available for the designated devices. This data is subject to change without notice and revision of this document. For browser-based versions of this data sheet, refer to the left-hand navigation.

PACKAGING INFORMATION

Orderable Device	Status (1)	Package Type	Package Drawing	Pins	Package Qty	Eco Plan (2)	Lead/Ball Finish (6)	MSL Peak Temp (3)	Op Temp (°C)	Device Marking (4/5)	Samples
LM3411AM5-3.3/NOPB	ACTIVE	SOT-23	DBV	5	1000	Green (RoHS & no Sb/Br)	CU SN	Level-1-260C-UNLIM	-40 to 85	D00A	Samples
LM3411AM5-5.0/NOPB	ACTIVE	SOT-23	DBV	5	1000	Green (RoHS & no Sb/Br)	CU SN	Level-1-260C-UNLIM	-40 to 85	D01A	Samples
LM3411AM5X-5.0/NOPB	ACTIVE	SOT-23	DBV	5	3000	Green (RoHS & no Sb/Br)	CU SN	Level-1-260C-UNLIM	-40 to 85	D01A	Samples
LM3411M5-3.3/NOPB	ACTIVE	SOT-23	DBV	5	1000	Green (RoHS & no Sb/Br)	CU SN	Level-1-260C-UNLIM	-40 to 85	D00B	Samples
LM3411M5-5.0/NOPB	ACTIVE	SOT-23	DBV	5	1000	Green (RoHS & no Sb/Br)	CU SN	Level-1-260C-UNLIM	-40 to 85	D01B	Samples
LM3411M5X-3.3/NOPB	ACTIVE	SOT-23	DBV	5	3000	Green (RoHS & no Sb/Br)	CU SN	Level-1-260C-UNLIM	-40 to 85	D00B	Samples
LM3411M5X-5.0/NOPB	ACTIVE	SOT-23	DBV	5	3000	Green (RoHS & no Sb/Br)	CU SN	Level-1-260C-UNLIM	-40 to 85	D01B	Samples

(1) The marketing status values are defined as follows:

ACTIVE: Product device recommended for new designs.

LIFEBUY: TI has announced that the device will be discontinued, and a lifetime-buy period is in effect.

NRND: Not recommended for new designs. Device is in production to support existing customers, but TI does not recommend using this part in a new design.

PREVIEW: Device has been announced but is not in production. Samples may or may not be available.

OBSOLETE: TI has discontinued the production of the device.

(2) **RoHS:** TI defines "RoHS" to mean semiconductor products that are compliant with the current EU RoHS requirements for all 10 RoHS substances, including the requirement that RoHS substance do not exceed 0.1% by weight in homogeneous materials. Where designed to be soldered at high temperatures, "RoHS" products are suitable for use in specified lead-free processes. TI may reference these types of products as "Pb-Free".

RoHS Exempt: TI defines "RoHS Exempt" to mean products that contain lead but are compliant with EU RoHS pursuant to a specific EU RoHS exemption.

Green: TI defines "Green" to mean the content of Chlorine (Cl) and Bromine (Br) based flame retardants meet JS709B low halogen requirements of <=100ppm threshold. Antimony trioxide based flame retardants must also meet the <=1000ppm threshold requirement.

(3) MSL, Peak Temp. - The Moisture Sensitivity Level rating according to the JEDEC industry standard classifications, and peak solder temperature.

(4) There may be additional marking, which relates to the logo, the lot trace code information, or the environmental category on the device.

(5) Multiple Device Markings will be inside parentheses. Only one Device Marking contained in parentheses and separated by a "-" will appear on a device. If a line is indented then it is a continuation of the previous line and the two combined represent the entire Device Marking for that device.

⁽⁶⁾ Lead/Ball Finish - Orderable Devices may have multiple material finish options. Finish options are separated by a vertical ruled line. Lead/Ball Finish values may wrap to two lines if the finish value exceeds the maximum column width.

Important Information and Disclaimer: The information provided on this page represents TI's knowledge and belief as of the date that it is provided. TI bases its knowledge and belief on information provided by third parties, and makes no representation or warranty as to the accuracy of such information. Efforts are underway to better integrate information from third parties. TI has taken and continues to take reasonable steps to provide representative and accurate information but may not have conducted destructive testing or chemical analysis on incoming materials and chemicals. TI and TI suppliers consider certain information to be proprietary, and thus CAS numbers and other limited information may not be available for release.

In no event shall TI's liability arising out of such information exceed the total purchase price of the TI part(s) at issue in this document sold by TI to Customer on an annual basis.

TAPE AND REEL INFORMATION

QUADRANT ASSIGNMENTS FOR PIN 1 ORIENTATION IN TAPE

*All dimensions are nominal

Device	Package Type	Package Drawing	Pins	SPQ	Reel Diameter (mm)	Reel Width W1 (mm)	A0 (mm)	B0 (mm)	K0 (mm)	P1 (mm)	W (mm)	Pin1 Quadrant
LM3411AM5-3.3/NOPB	SOT-23	DBV	5	1000	178.0	8.4	3.2	3.2	1.4	4.0	8.0	Q3
LM3411AM5-5.0/NOPB	SOT-23	DBV	5	1000	178.0	8.4	3.2	3.2	1.4	4.0	8.0	Q3
LM3411AM5X-5.0/NOPB	SOT-23	DBV	5	3000	178.0	8.4	3.2	3.2	1.4	4.0	8.0	Q3
LM3411M5-3.3/NOPB	SOT-23	DBV	5	1000	178.0	8.4	3.2	3.2	1.4	4.0	8.0	Q3
LM3411M5-5.0/NOPB	SOT-23	DBV	5	1000	178.0	8.4	3.2	3.2	1.4	4.0	8.0	Q3
LM3411M5X-3.3/NOPB	SOT-23	DBV	5	3000	178.0	8.4	3.2	3.2	1.4	4.0	8.0	Q3
LM3411M5X-5.0/NOPB	SOT-23	DBV	5	3000	178.0	8.4	3.2	3.2	1.4	4.0	8.0	Q3

TAPE AND REEL BOX DIMENSIONS

*All dimensions are nominal

Device	Package Type	Package Drawing	Pins	SPQ	Length (mm)	Width (mm)	Height (mm)
LM3411AM5-3.3/NOPB	SOT-23	DBV	5	1000	210.0	185.0	35.0
LM3411AM5-5.0/NOPB	SOT-23	DBV	5	1000	210.0	185.0	35.0
LM3411AM5X-5.0/NOPB	SOT-23	DBV	5	3000	210.0	185.0	35.0
LM3411M5-3.3/NOPB	SOT-23	DBV	5	1000	210.0	185.0	35.0
LM3411M5-5.0/NOPB	SOT-23	DBV	5	1000	210.0	185.0	35.0
LM3411M5X-3.3/NOPB	SOT-23	DBV	5	3000	210.0	185.0	35.0
LM3411M5X-5.0/NOPB	SOT-23	DBV	5	3000	210.0	185.0	35.0

EXAMPLE BOARD LAYOUT

DBV0005A

SOT-23 - 1.45 mm max height

SMALL OUTLINE TRANSISTOR



LAND PATTERN EXAMPLE
EXPOSED METAL SHOWN
SCALE:15X



SOLDER MASK DETAILS

4214839/D 11/2018

NOTES: (continued)

- 5. Publication IPC-7351 may have alternate designs.
- 6. Solder mask tolerances between and around signal pads can vary based on board fabrication site.

EXAMPLE STENCIL DESIGN

DBV0005A

SOT-23 - 1.45 mm max height

SMALL OUTLINE TRANSISTOR



SOLDER PASTE EXAMPLE
BASED ON 0.125 mm THICK STENCIL
SCALE:15X

4214839/D 11/2018

NOTES: (continued)

7. Laser cutting apertures with trapezoidal walls and rounded corners may offer better paste release. IPC-7525 may have alternate design recommendations.
8. Board assembly site may have different recommendations for stencil design.

IMPORTANT NOTICE AND DISCLAIMER

TI PROVIDES TECHNICAL AND RELIABILITY DATA (INCLUDING DATASHEETS), DESIGN RESOURCES (INCLUDING REFERENCE DESIGNS), APPLICATION OR OTHER DESIGN ADVICE, WEB TOOLS, SAFETY INFORMATION, AND OTHER RESOURCES "AS IS" AND WITH ALL FAULTS, AND DISCLAIMS ALL WARRANTIES, EXPRESS AND IMPLIED, INCLUDING WITHOUT LIMITATION ANY IMPLIED WARRANTIES OF MERCHANTABILITY, FITNESS FOR A PARTICULAR PURPOSE OR NON-INFRINGEMENT OF THIRD PARTY INTELLECTUAL PROPERTY RIGHTS.



These resources are intended for skilled developers designing with TI products. You are solely responsible for (1) selecting the appropriate TI products for your application, (2) designing, validating and testing your application, and (3) ensuring your application meets applicable standards, and any other safety, security, or other requirements. These resources are subject to change without notice. TI grants you permission to use these resources only for development of an application that uses the TI products described in the resource. Other reproduction and display of these resources is prohibited. No license is granted to any other TI intellectual property right or to any third party intellectual property right. TI disclaims responsibility for, and you will fully indemnify TI and its representatives against, any claims, damages, costs, losses, and liabilities arising out of your use of these resources.

TI's products are provided subject to TI's Terms of Sale (www.ti.com/legal/termsofsale.html) or other applicable terms available either on ti.com or provided in conjunction with such TI products. TI's provision of these resources does not expand or otherwise alter TI's applicable warranties or warranty disclaimers for TI products.

Mailing Address: Texas Instruments, Post Office Box 655303, Dallas, Texas 75265
Copyright © 2019, Texas Instruments Incorporated

Looking for pricing, stock, or lifecycle information?

Click below to explore more details on WIN SOURCE:

-  [View LM3411AM5-5.0/NOPB on WIN SOURCE](#)
-  [Texas Instruments](#) Information

Optimize Your Supply Chain with WIN SOURCE Solutions

-  Global Sourcing Solution
-  Obsolete Management
-  Cost Control Management
-  Shortage Management
-  Alternative Solution
-  Excess Inventory Management