



**THE DATASHEET OF  
AD7916BRMZ**



**FEATURES**
**Low power dissipation**
**AD7915**
**4 mW at 1 MSPS (VDD only)**
**7 mW at 1 MSPS (total)**
**AD7916**
**2 mW at 500 kSPS (VDD only)**
**3.7 mW at 500 kSPS (total)**
**16-bit resolution with no missing codes**
**Throughput: 1 MSPS (AD7915)/500 kSPS (AD7916)**
**INL:  $\pm 0.4$  LSB typical,  $\pm 1$  LSB maximum**
**SNR: 94 dB at 1 kHz,  $V_{REF} = 5$  V**
**SINAD: 93.5 dB at 1 kHz,  $V_{REF} = 5$  V**
**THD:  $-118.5$  dB at 1 kHz**
**Dynamic range: 95.5 dB,  $V_{REF} = 5$  V**
**True differential analog input range:  $\pm V_{REF}$** 
**0 V to  $V_{REF}$  with  $V_{REF}$  between 2.4 V and 5.1 V**
**No pipeline delay**
**Single-supply 2.5 V operation with 1.8 V/2.5 V/3 V/5 V logic interface**
**Proprietary serial interface: SPI-/QSPI-/MICROWIRE™-/DSP-compatible<sup>1</sup>**
**Ability to daisy-chain multiple ADCs**
**10-lead packages: MSOP and 3 mm  $\times$  3 mm LFCSP**
**APPLICATIONS**
**Battery-powered equipment**
**Data acquisition systems**
**Medical instruments**
**Seismic data acquisition systems**
**GENERAL DESCRIPTION**

The AD7915/AD7916 are 16-bit, successive approximation, analog-to-digital converters (ADCs) that operate from a single power supply, VDD. They contain a low power, high speed, 16-bit sampling ADC and a versatile serial interface port. On the CNV rising edge, the AD7915/AD7916 sample the voltage difference between the IN+ and IN– pins. The voltages on these pins typically swing in opposite phases between 0 V and  $V_{REF}$ . The reference voltage, REF, is applied externally and can be set independent of the supply voltage, VDD. The power consumption of the AD7915/AD7916 scales linearly with throughput.

The AD7915/AD7916 are serial peripheral interface (SPI) compatible, which features the ability, using the SDI input, to daisy-chain several ADCs on a single 3-wire bus. They are compatible with 1.8 V, 2.5 V, 3 V, and 5 V logic using the separate VIO supply.

The AD7915/AD7916 are available in a 10-lead MSOP or a 10-lead LFCSP with operation specified from  $-40^{\circ}\text{C}$  to  $+125^{\circ}\text{C}$ .

**Table 1. MSOP, LFCSP 14-/16-/18-Bit PulSAR® ADCs**

Bits	100 kSPS	250 kSPS	400 kSPS to 500 kSPS	$\geq 1000$ kSPS
18 <sup>1</sup>	AD7989-1 <sup>2</sup>	AD7691 <sup>2</sup>	AD7690 <sup>2</sup> AD7989-5 <sup>2</sup>	AD7982 <sup>2</sup> AD7984 <sup>2</sup>
16 <sup>1</sup>	AD7684	AD7687 <sup>2</sup>	AD7688 <sup>2</sup> AD7693 <sup>2</sup> AD7916 <sup>2</sup>	AD7915 <sup>2</sup>
16 <sup>3</sup>	AD7680 AD7683 AD7988-1 <sup>2</sup>	AD7685 <sup>2</sup> AD7694	AD7686 <sup>2</sup> AD7988-5 <sup>2</sup>	AD7980 <sup>2</sup> AD7983 <sup>2</sup>
14 <sup>3</sup>	AD7940	AD7942 <sup>2</sup>	AD7946 <sup>2</sup>	

<sup>1</sup> True differential.

<sup>2</sup> Pin-for-pin compatible.

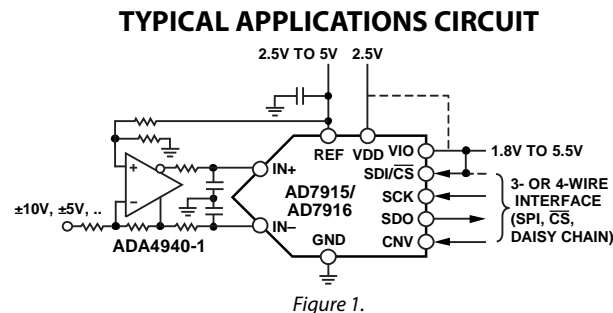
<sup>3</sup> Pseudo differential.

<sup>1</sup> Protected by U.S. Patent 6,703,961.

## TABLE OF CONTENTS

Features .....	1	Single to Differential Driver .....	16
Applications.....	1	Voltage Reference Input .....	16
General Description .....	1	Power Supply.....	16
Typical Applications Circuit.....	1	Digital Interface .....	16
Revision History .....	2	$\overline{\text{CS}}$ Mode, 3-Wire, Without Busy Indicator .....	17
Specifications.....	3	$\overline{\text{CS}}$ Mode 3-Wire, with Busy Indicator .....	18
Timing Specifications .....	5	$\overline{\text{CS}}$ Mode, 4-Wire, Without Busy Indicator .....	19
Absolute Maximum Ratings.....	6	$\overline{\text{CS}}$ Mode 4-Wire with Busy Indicator .....	20
ESD Caution.....	6	Chain Mode, Without Busy Indicator .....	21
Pin Configurations and Function Descriptions .....	7	Chain Mode with Busy Indicator .....	22
Typical Performance Characteristics .....	8	Applications Information .....	23
Terminology .....	12	Interfacing to Blackfin DSP .....	23
Theory of Operation .....	13	Layout .....	23
Circuit Information.....	13	Evaluating AD7915/AD7916 Performance .....	24
Converter Operation.....	13	Outline Dimensions .....	25
Typical Connection Diagram .....	14	Ordering Guide .....	25
Analog Inputs.....	15		
Driver Amplifier Choice.....	15		

## REVISION HISTORY

3/15—Revision 0: Initial Version

## SPECIFICATIONS

VDD = 2.5 V, VIO = 2.3 V to 5.5 V, VREF = 5 V, TA = -40°C to +125°C, unless otherwise noted.

Table 2.

Parameter	Test Conditions/Comments	Min	Typ	Max	Unit
RESOLUTION		16			Bits
ANALOG INPUT					
Voltage Range	IN+ – IN–	–VREF		+VREF	V
Absolute Input Voltage	IN+, IN–	–0.1		VREF + 0.1	V
Common-Mode Input Range	IN+, IN–	VREF × 0.475	VREF × 0.5	VREF × 0.525	V
Analog Input Common-Mode Rejection Ratio (CMRR)	fIN = 450 kHz		60		dB
Leakage Current at 25°C	Acquisition phase		1		nA
Input Impedance			See the Analog Inputs section		
ACCURACY					
No Missing Codes		16			Bits
Differential Nonlinearity (DNL) Error	VREF = 5 V	–0.9	±0.4	+0.9	LSB <sup>1</sup>
	VREF = 2.5 V		±0.5		LSB <sup>1</sup>
Integral Nonlinearity (INL) Error	VREF = 5 V	–1	±0.4	+1	LSB <sup>1</sup>
	VREF = 2.5 V		±0.5		LSB <sup>1</sup>
Transition Noise	VREF = 5 V		0.75		LSB <sup>1</sup>
	VREF = 2.5 V		1.2		LSB <sup>1</sup>
Gain Error <sup>2</sup>	TMIN to TMAX	–10	0	+10	LSB <sup>1</sup>
Gain Error Temperature Drift			±0.23		ppm/°C
Zero Error <sup>2</sup>	TMIN to TMAX	–0.5	±0.08	+0.5	mV
Zero Temperature Drift			0.28		ppm/°C
Power Supply Sensitivity	VDD = 2.5 V ± 5%		±0.1		dB
THROUGHPUT					
AD7915 Conversion Rate		0		1000	kSPS
AD7916 Conversion Rate		0		500	kSPS
Transient Response	Full-scale step			290	ns
AC ACCURACY					
Dynamic Range	VREF = 5 V		95.5		dB <sup>3</sup>
	VREF = 2.5 V		92		dB <sup>3</sup>
Oversampled Dynamic Range <sup>4</sup>	fO = 10 kSPS		113.5		dB <sup>3</sup>
Signal-to-Noise Ratio (SNR)	fIN = 1 kHz, VREF = 5 V	93	94		dB <sup>3</sup>
	fIN = 1 kHz, VREF = 2.5 V	89	91		dB <sup>3</sup>
Spurious-Free Dynamic Range (SFDR)	fIN = 1 kHz		–118		dB <sup>3</sup>
Total Harmonic Distortion (THD)	fIN = 1 kHz		–118.5		dB <sup>3</sup>
Signal-to-Noise-and-Distortion Ratio (SINAD)	fIN = 1 kHz, VREF = 5 V		93.5		dB <sup>3</sup>
	fIN = 1 kHz, VREF = 2.5 V		90.5		dB <sup>3</sup>
REFERENCE					
Voltage Range		2.4		5.1	V
Load Current	VREF = 5 V		330		μA
SAMPLING DYNAMICS					
–3 dB Input Bandwidth			10		MHz
Aperture Delay	VDD = 2.5 V		2		ns

Parameter	Test Conditions/Comments	Min	Typ	Max	Unit
<b>DIGITAL INPUTS</b>					
Logic Levels					
$V_{IL}$	$V_{IO} > 3\text{ V}$	-0.3		$+0.3 \times V_{IO}$	V
	$V_{IO} \leq 3\text{ V}$	-0.3		$+0.1 \times V_{IO}$	V
$V_{IH}$	$V_{IO} > 3\text{ V}$	$0.7 \times V_{IO}$		$V_{IO} + 0.3$	V
	$V_{IO} \leq 3\text{ V}$	$0.9 \times V_{IO}$		$V_{IO} + 0.3$	V
$I_{IL}$		-1		+1	$\mu\text{A}$
$I_{IH}$		-1		+1	$\mu\text{A}$
<b>DIGITAL OUTPUTS</b>					
Data Format		Serial, 16 bits, twos complement			
Pipeline Delay		Conversion results available immediately after completed conversion			
$V_{OL}$	$I_{SINK} = 500\ \mu\text{A}$			0.4	V
$V_{OH}$	$I_{SOURCE} = -500\ \mu\text{A}$	$V_{IO} - 0.3$			V
<b>POWER SUPPLIES</b>					
VDD		2.375	2.5	2.625	V
VIO	Specified performance	2.3		5.5	V
VIO Range	Functional range	1.8		5.5	V
Standby Current <sup>5,6</sup>	VDD and VIO = 2.5 V, $T_A = 25^\circ\text{C}$		0.35		$\mu\text{A}$
<b>AD7915</b> Power Dissipation	VDD = 2.625 V, $V_{REF} = 5\text{ V}$ , VIO = 3 V				
Total	10 kSPS throughput		70		$\mu\text{W}$
	1 MSPS throughput		7	9	mW
VDD Only			4		mW
REF Only			1.7		mW
VIO Only			1.3		mW
<b>AD7916</b> Power Dissipation	VDD = 2.625 V, $V_{REF} = 5\text{ V}$ , VIO = 3 V				
Total	500 kSPS throughput		3.7	4.5	mW
VDD Only			2		mW
REF Only			0.85		mW
VIO Only			0.85		mW
Energy per Conversion			7.0		nJ/sample
<b>TEMPERATURE RANGE</b>					
Specified Performance	$T_{MIN}$ to $T_{MAX}$	-40		+125	$^\circ\text{C}$

<sup>1</sup> 1LSB means least significant bit. With the  $\pm 5\text{ V}$  input range, 1LSB is 152.6  $\mu\text{V}$ .

<sup>2</sup> See the Terminology section. These specifications include full temperature range variation but not the error contribution from the external reference.

<sup>3</sup> All specifications expressed in decibels are referred to a full-scale input FSR and tested with an input signal at 0.5 dB below full scale, unless otherwise specified.

<sup>4</sup> Dynamic range is obtained by oversampling the ADC running at a throughput,  $f_s$ , of 1 MSPS followed by postdigital filtering with an output word rate of  $f_o$ .

<sup>5</sup> With all digital inputs forced to VIO or ground as required.

<sup>6</sup> During acquisition phase.

## TIMING SPECIFICATIONS

$T_A = -40^\circ\text{C}$  to  $+125^\circ\text{C}$ ,  $V_{DD} = 2.37\text{ V}$  to  $2.63\text{ V}$ ,  $V_{IO} = 2.3\text{ V}$  to  $5.5\text{ V}$ ,  $C_{LOAD\_SDO} = 20\text{ pF}$ , unless otherwise noted. See Figure 2 for voltage levels.

Table 3.

Parameter	Symbol	Min	Typ	Max	Unit
<b>AD7915</b>					
Throughput Rate				1	MSPS
Conversion Time: CNV Rising Edge to Data Available	$t_{CONV}$	500		710	ns
Acquisition Time	$t_{ACQ}$	290			ns
Time Between Conversions	$t_{CYC}$	1			$\mu\text{s}$
<b>AD7916</b>					
Throughput Rate				500	KSPS
Conversion Time: CNV Rising Edge to Data Available	$t_{CONV}$	0.5		1.6	$\mu\text{s}$
Acquisition Time	$t_{ACQ}$	400			ns
Time Between Conversions	$t_{CYC}$	2			$\mu\text{s}$
CNV Pulse Width ( $\overline{\text{CS}}$ Mode)	$t_{CNWH}$	10			ns
SCK Period ( $\overline{\text{CS}}$ Mode)	$t_{SCK}$				
VIO Above 4.5 V		10.5			ns
VIO Above 3 V		12			ns
VIO Above 2.7 V		13			ns
VIO Above 2.3 V		15			ns
SCK Period (Chain Mode)	$t_{SCK}$				
VIO Above 4.5 V		11.5			ns
VIO Above 3 V		13			ns
VIO Above 2.7 V		14			ns
VIO Above 2.3 V		16			ns
SCK Low Time	$t_{SCKL}$	4.5			ns
SCK High Time	$t_{SCKH}$	4.5			ns
SCK Falling Edge to Data Remains Valid	$t_{HSDO}$	3			ns
SCK Falling Edge to Data Valid Delay	$t_{DSDO}$				
VIO Above 4.5 V				9.5	ns
VIO Above 3 V				11	ns
VIO Above 2.7 V				12	ns
VIO Above 2.3 V				14	ns
CNV or SDI Low to SDO D15 MSB Valid ( $\overline{\text{CS}}$ Mode)	$t_{EN}$				
VIO Above 3 V				10	ns
VIO Above 2.3 V				15	ns
CNV or SDI High or Last SCK Falling Edge to SDO High Impedance ( $\overline{\text{CS}}$ Mode)	$t_{DIS}$			20	ns
SDI Valid Setup Time from CNV Rising Edge ( $\overline{\text{CS}}$ Mode)	$t_{SSDICNV}$	5			ns
SDI Valid Hold Time from CNV Rising Edge ( $\overline{\text{CS}}$ Mode)	$t_{HSDICNV}$	2			ns
SCK Valid Setup Time from CNV Rising Edge (Chain Mode)	$t_{SSCKCNV}$	5			ns
SCK Valid Hold Time from CNV Rising Edge (Chain Mode)	$t_{HSCCKNV}$	5			ns
SDI Valid Setup Time from SCK Falling Edge (Chain Mode)	$t_{SSDISCK}$	2			ns
SDI Valid Hold Time from SCK Falling Edge (Chain Mode)	$t_{HSDISCK}$	3			ns
SDI High to SDO High (Chain Mode with Busy Indicator)	$t_{DSDOSDI}$			15	ns

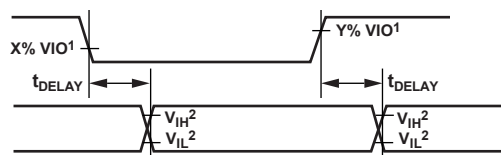

<sup>1</sup>FOR  $V_{IO} \leq 3.0\text{ V}$ ,  $X = 90$  AND  $Y = 10$ ; FOR  $V_{IO} > 3.0\text{ V}$ ,  $X = 70$  AND  $Y = 30$ .  
<sup>2</sup>MINIMUM  $V_{IH}$  AND MAXIMUM  $V_{IL}$  USED. SEE THE DIGITAL INPUTS SPECIFICATIONS IN TABLE 3.

12863-003

Figure 2. Voltage Levels for Timing

## ABSOLUTE MAXIMUM RATINGS

Table 4.

Parameter	Rating
Analog Inputs IN+, IN– to GND <sup>1</sup>	–0.3 V to $V_{REF} + 0.3$ V or $\pm 130$ mA
Supply Voltage REF, VIO to GND	–0.3 V to +6.0 V
VDD to GND	–0.3 V to +3.0 V
VDD to VIO	–6 V to +3 V
Digital Inputs to GND	–0.3 V to VIO + 0.3 V
Digital Output to GND	–0.3 V to VIO + 0.3 V
Storage Temperature Range	–65°C to +150°C
Junction Temperature	150°C
$\theta_{JA}$ Thermal Impedance 10-Lead MSOP	200°C/W
10-Lead LFCSP_WD	48.7°C/W
$\theta_{JC}$ Thermal Impedance 10-Lead MSOP	44°C/W
10-Lead LFCSP_WD	2.96°C/W
Reflow Soldering	JEDEC Standard (J-STD-020)

<sup>1</sup> See the Analog Inputs section for an explanation of IN+ and IN–.

Stresses at or above those listed under Absolute Maximum Ratings may cause permanent damage to the product. This is a stress rating only; functional operation of the product at these or any other conditions above those indicated in the operational section of this specification is not implied. Operation beyond the maximum operating conditions for extended periods may affect product reliability.

### ESD CAUTION



**ESD (electrostatic discharge) sensitive device.** Charged devices and circuit boards can discharge without detection. Although this product features patented or proprietary protection circuitry, damage may occur on devices subjected to high energy ESD. Therefore, proper ESD precautions should be taken to avoid performance degradation or loss of functionality.

# PIN CONFIGURATIONS AND FUNCTION DESCRIPTIONS

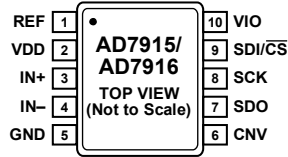
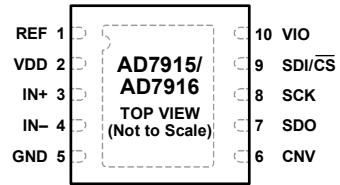

Figure 3. 10-Lead MSOP Pin Configuration



NOTES  
 1. THE EXPOSED PAD CAN BE CONNECTED TO GND. THIS CONNECTION IS NOT REQUIRED TO MEET THE ELECTRICAL PERFORMANCES.

Figure 4. 10-Lead LFCSP Pin Configuration

Table 5. Pin Function Descriptions

Pin No.	Mnemonic	Type <sup>1</sup>	Description
1	REF	AI	Reference Input Voltage. The REF range is 2.4 V to 5.1 V. This pin is referred to the GND pin and must be decoupled closely to the GND pin with a 10 μF capacitor.
2	VDD	P	Power Supply.
3	IN+	AI	Differential Positive Analog Input.
4	IN-	AI	Differential Negative Analog Input.
5	GND	P	Power Supply Ground.
6	CNV	DI	Conversion Input. This input has multiple functions. On its leading edge, CNV initiates the conversions and selects the interface mode of the device: chain mode or chip select (CS) mode. In CS mode, the SDO pin is enabled when CNV is low. In chain mode, the data is read when CNV is high.
7	SDO	DO	Serial Data Output. The conversion result is output on this pin. It is synchronized to SCK.
8	SCK	DI	Serial Data Clock Input. When the device is selected, the conversion result is shifted out by this clock.
9	SDI/ $\overline{\text{CS}}$	DI	Serial Data Input/Chip Select. This input has multiple functions. It selects the interface mode of the ADC as follows:  Chain mode is selected if this pin is low during the CNV rising edge. In this mode, $\overline{\text{SDI/CS}}$ is used as a data input to daisy-chain the conversion results of two or more ADCs onto a single SDO line. The digital data level on $\overline{\text{SDI/CS}}$ is output on SDO with a delay of 16 SCK cycles.  $\overline{\text{CS}}$ mode is selected if $\overline{\text{SDI/CS}}$ is high during the CNV rising edge. In this mode, either $\overline{\text{SDI/CS}}$ or CNV can enable the serial output signals when low.
10	VIO	P	Input/Output Interface Digital Power. This pin is nominally at the same supply as the host interface (1.8 V, 2.5 V, 3 V, or 5 V).
	EP		Exposed Pad. For the lead frame chip scale package (LFCSP), the exposed pad can be connected to GND. This connection is not required to meet the electrical performances.

<sup>1</sup>AI is analog input, P is power, DI is digital input, and DO is digital output.

TYPICAL PERFORMANCE CHARACTERISTICS

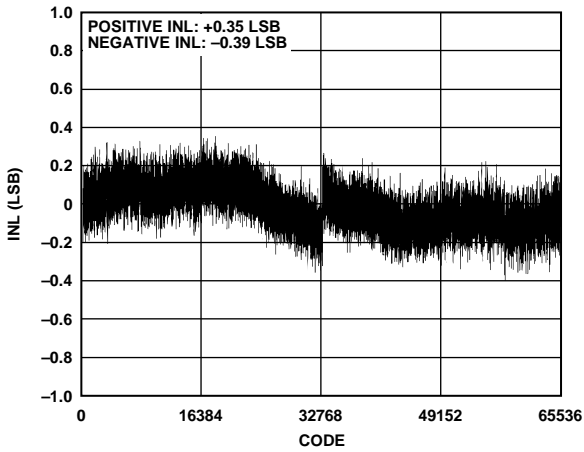

Figure 5. Integral Nonlinearity (INL) vs. Code, REF = 5 V

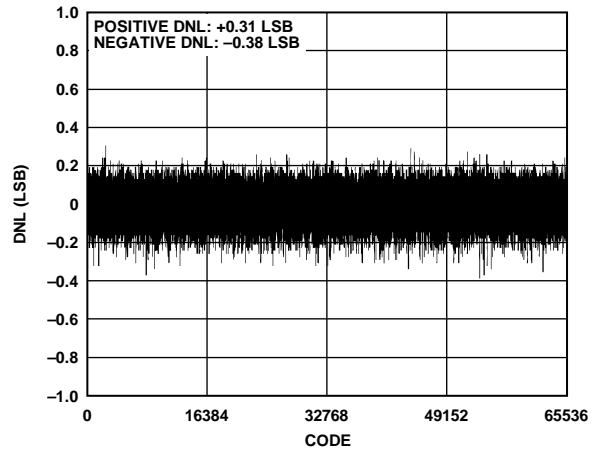

Figure 8. Differential Nonlinearity (DNL) vs. Code, REF = 5 V

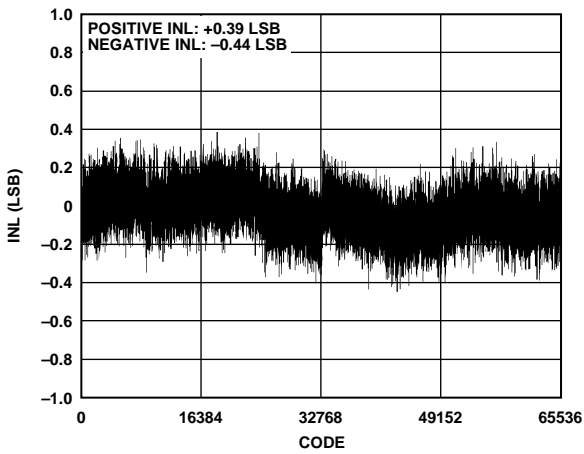

Figure 6. INL vs. Code, REF = 2.5 V

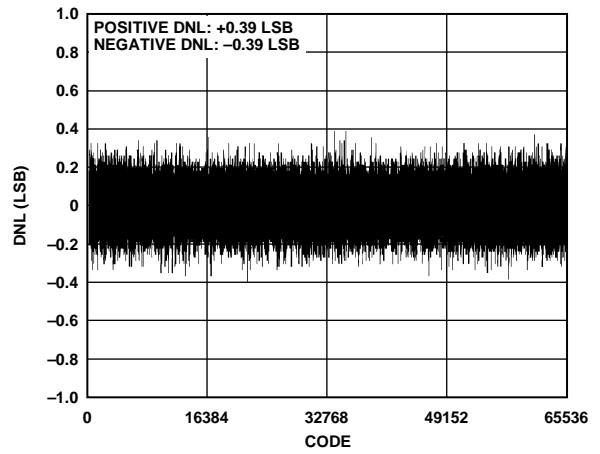

Figure 9. DNL vs. Code, REF = 2.5 V

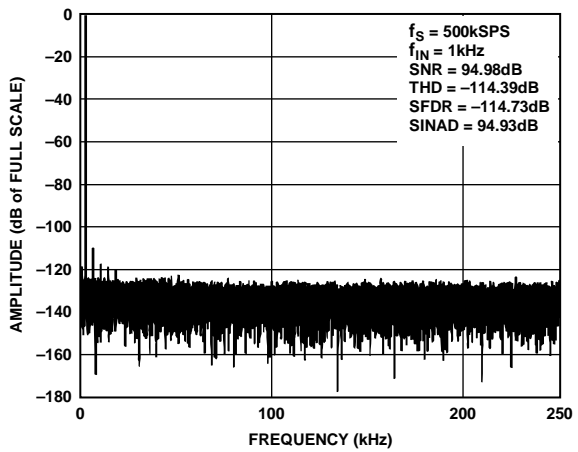

Figure 7. AD7916 FFT Plot, REF = 5 V

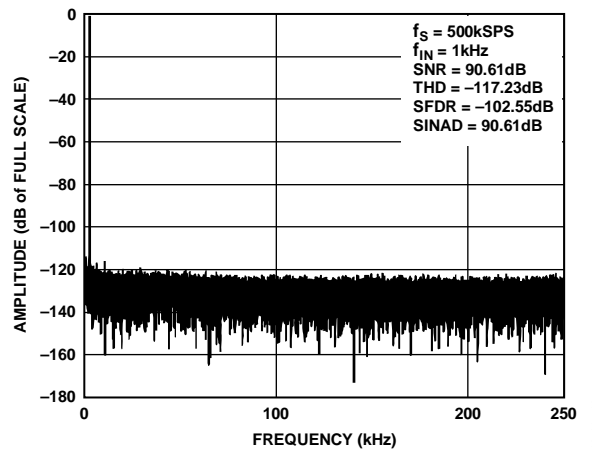

Figure 10. AD7916 FFT Plot, REF = 2.5 V

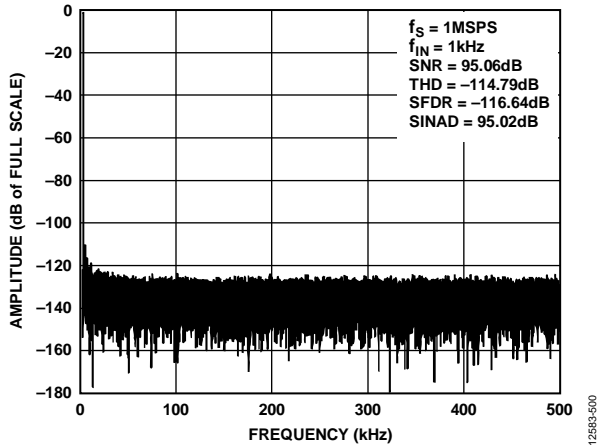

Figure 11. AD7915 FFT Plot, REF = 5 V

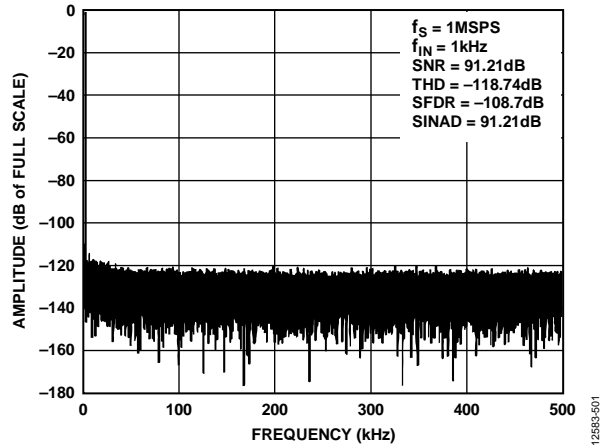

Figure 14. AD7915 FFT Plot, REF = 2.5 V

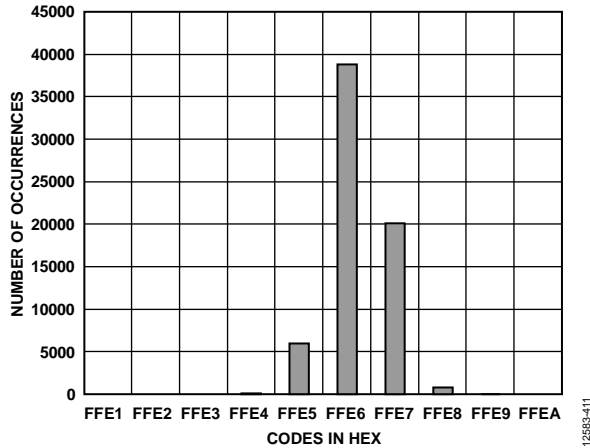

Figure 12. Histogram of a DC Input at the Code Center, REF = 5 V

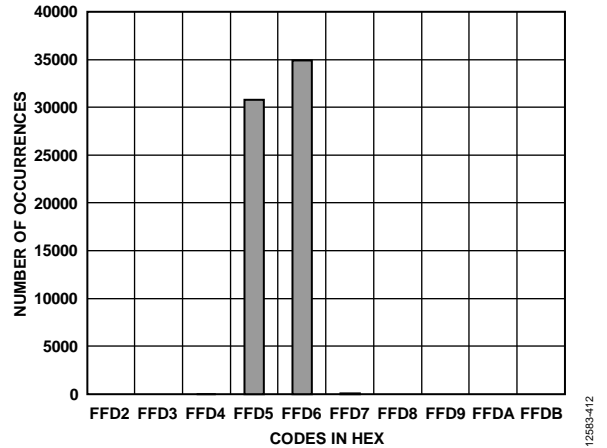

Figure 15. Histogram of a DC Input at the Code Transition, REF = 5 V

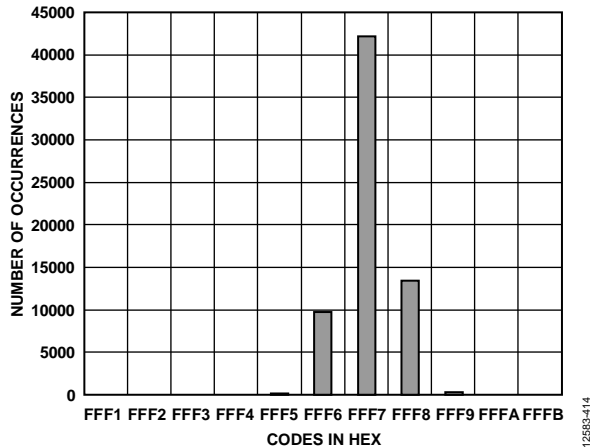

Figure 13. Histogram of a DC Input at the Code Center, REF = 2.5 V

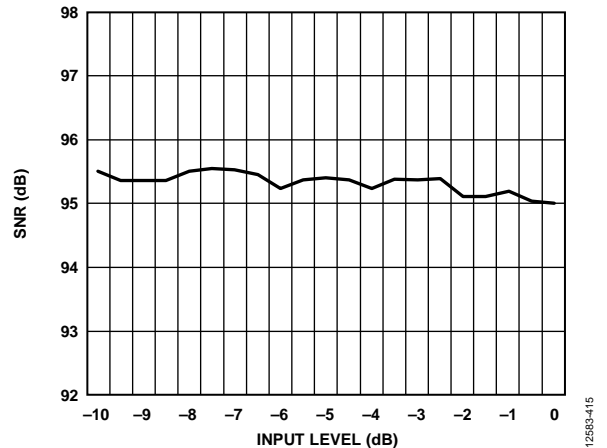

Figure 16. SNR vs. Input Level

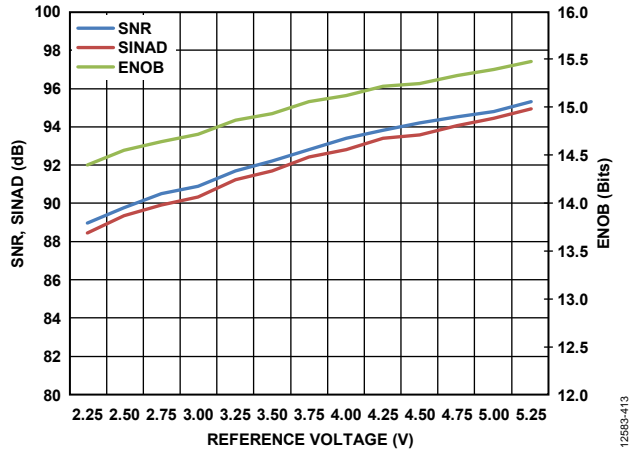

Figure 17. SNR, SINAD, and ENOB vs. Reference Voltage

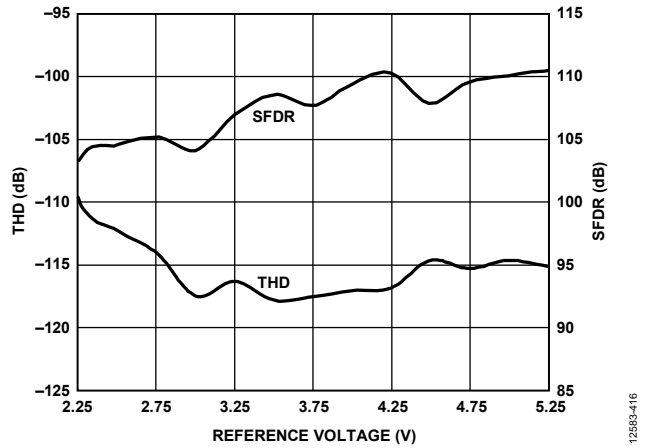

Figure 20. THD and SFDR vs. Reference Voltage

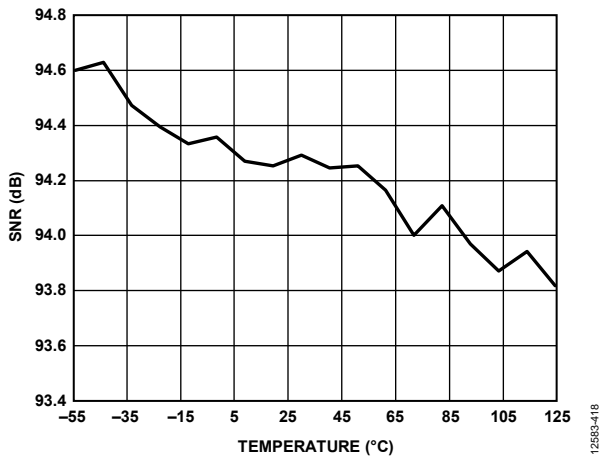

Figure 18. SNR vs. Temperature

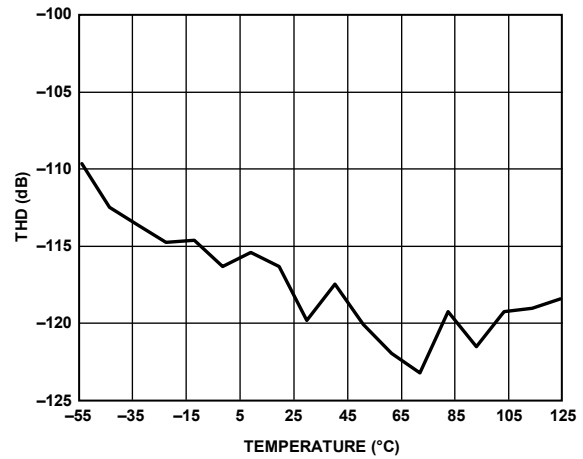

Figure 21. THD vs. Temperature

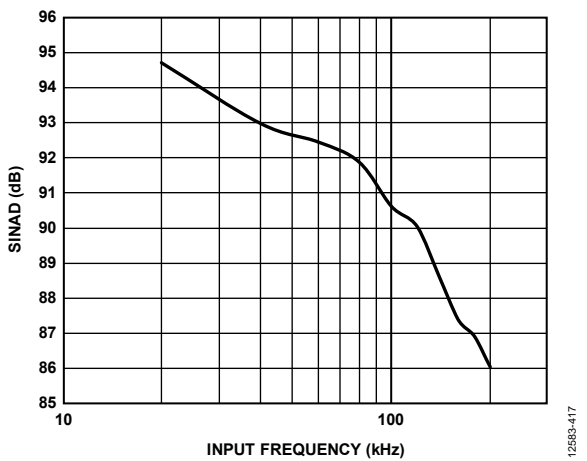

Figure 19. SINAD vs. Input Frequency

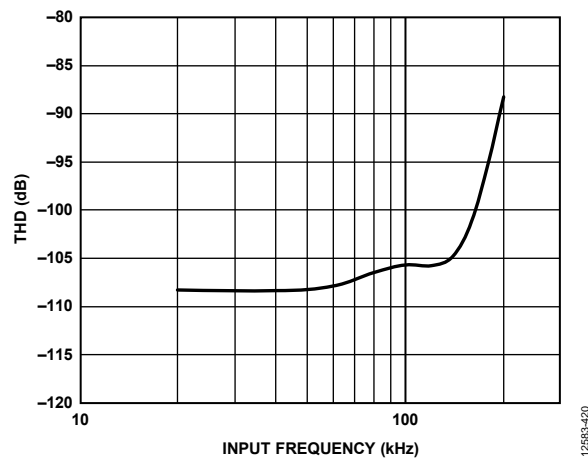

Figure 22. THD vs. Input Frequency

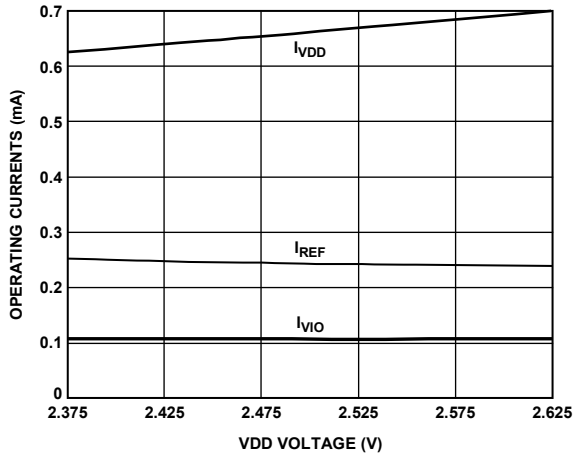

Figure 23. Operating Currents vs. VDD Voltage (AD7916)

12583-118

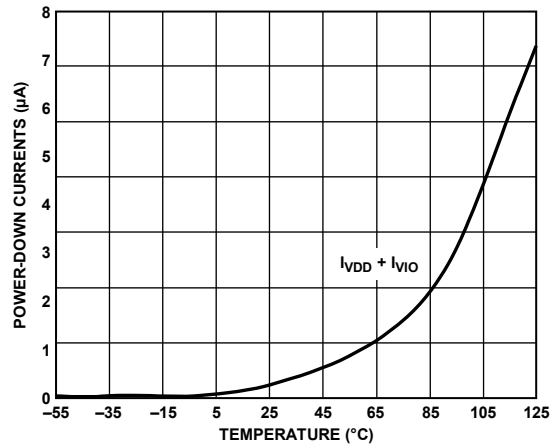

Figure 26. Power-Down Currents vs. Temperature

12583-303

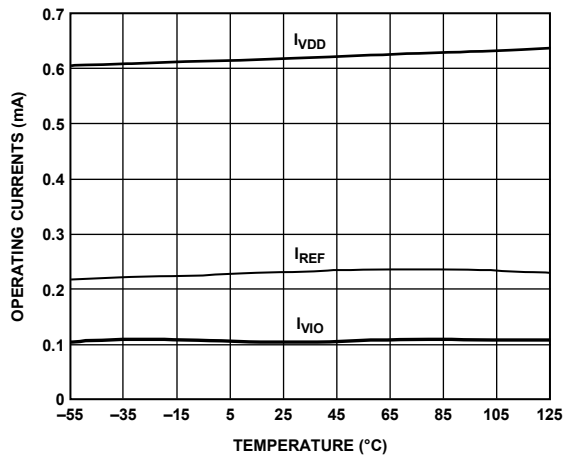

Figure 24. Operating Currents vs. Temperature (AD7916)

12583-120

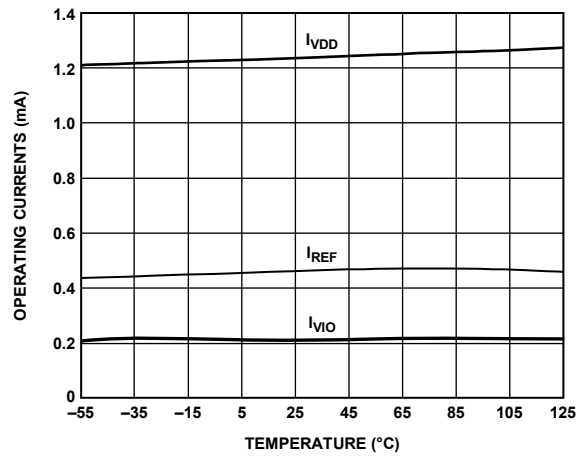

Figure 27. Operating Currents vs. Temperature (AD7915)

12583-123

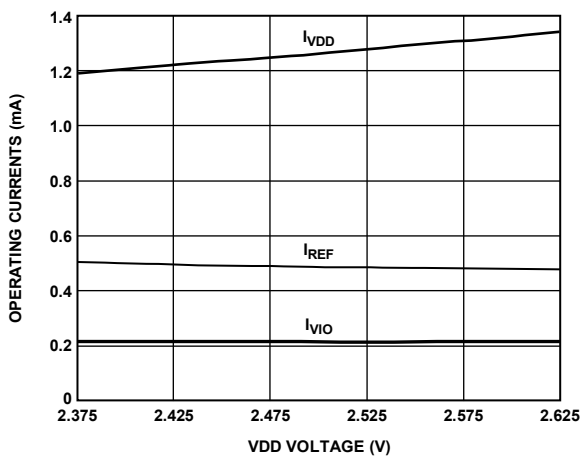

Figure 25. Operating Currents vs. VDD Voltage (AD7915)

12583-121

## TERMINOLOGY

### Integral Nonlinearity Error (INL)

INL refers to the deviation of each individual code from a line drawn from negative full scale through positive full scale. The point used as negative full scale occurs  $\frac{1}{2}$  LSB before the first code transition. Positive full scale is defined as a level  $1\frac{1}{2}$  LSB beyond the last code transition. The deviation is measured from the middle of each code to the true straight line (see Figure 29).

### Differential Nonlinearity Error (DNL)

In an ideal ADC, code transitions are 1 LSB apart. DNL is the maximum deviation from this ideal value. It is often specified in terms of resolution for which no missing codes are guaranteed.

### Zero Error

Zero error is the difference between the ideal midscale voltage, that is, 0 V, and the actual voltage producing the midscale output code, that is, 0 LSB.

### Gain Error

The first transition (from 100 ... 00 to 100 ... 01) occurs at a level  $\frac{1}{2}$  LSB above nominal negative full scale ( $-4.999981$  V for the  $\pm 5$  V range). The last transition (from 011 ... 10 to 011 ... 11) occurs for an analog voltage  $1\frac{1}{2}$  LSB below the nominal full scale ( $+4.999943$  V for the  $\pm 5$  V range). The gain error is the deviation of the difference between the actual level of the last transition and the actual level of the first transition from the difference between the ideal levels.

### Spurious-Free Dynamic Range (SFDR)

SFDR is the difference, in decibels (dB), between the rms amplitude of the input signal and the peak spurious signal.

### Effective Number of Bits (ENOB)

ENOB is a measurement of the resolution with a sine wave input. It is related to SINAD as follows:

$$ENOB = (SINAD_{dB} - 1.76)/6.02$$

ENOB is expressed in bits.

### Noise-Free Code Resolution

Noise-free code resolution is the number of bits beyond which it is impossible to distinctly resolve individual codes. It is calculated as

$$Noise\text{-Free Code Resolution} = \log_2(2^N/Peak\text{-to-Peak Noise})$$

and is expressed in bits.

### Effective Resolution

Effective resolution is calculated as

$$Effective\ Resolution = \log_2(2^N/RMS\ Input\ Noise)$$

and is expressed in bits.

### Total Harmonic Distortion (THD)

THD is the ratio of the rms sum of the first five harmonic components to the rms value of a full-scale input signal and is expressed in decibels.

### Dynamic Range

Dynamic range is the ratio of the rms value of the full scale to the total rms noise measured with the inputs shorted together. The value for dynamic range is expressed in decibels. It is measured with a signal at  $-60$  dB so that it includes all noise sources and DNL artifacts.

### Signal-to-Noise Ratio (SNR)

SNR is the ratio of the rms value of the actual input signal to the rms sum of all other spectral components below the Nyquist frequency, excluding harmonics and dc. The value for SNR is expressed in decibels.

### Signal-to-Noise-and-Distortion Ratio (SINAD)

SINAD is the ratio of the rms value of the actual input signal to the rms sum of all other spectral components that are less than the Nyquist frequency, including harmonics but excluding dc. The value of SINAD is expressed in decibels.

### Aperture Delay

Aperture delay is the measure of the acquisition performance and is the time between the rising edge of the CNV input and when the input signal is held for a conversion.

### Transient Response

Transient response is the time required for the ADC to accurately acquire its input after a full-scale step function is applied.

## THEORY OF OPERATION

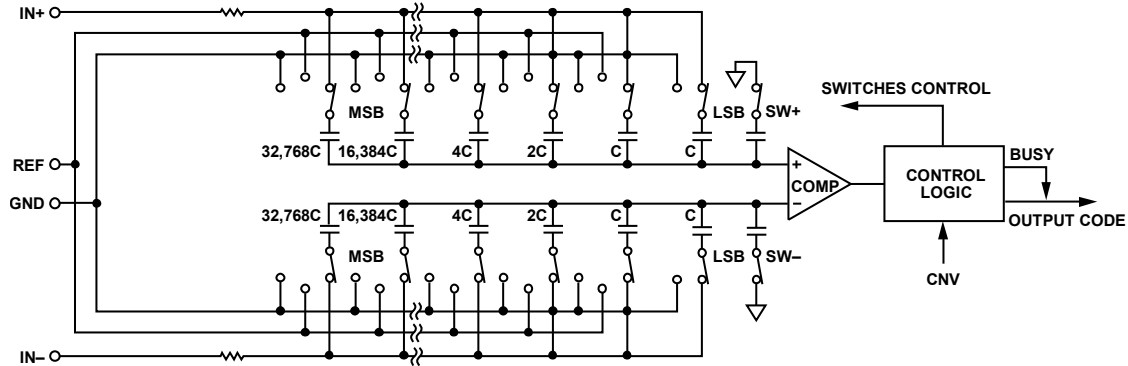

Figure 28. ADC Simplified Schematic

12583-020

### CIRCUIT INFORMATION

The [AD7915/AD7916](#) are high speed, low power, single-supply, precise, 16-bit ADCs that use a successive approximation architecture.

The [AD7916](#) can convert 500,000 samples per second (500 kSPS), whereas the [AD7915](#) can convert 1,000,000 samples per second (1 MSPS); both devices power down between conversions. When operating at 1 MSPS, the [AD7915](#) typically consumes 7 mW, making the ADC ideal for battery-powered applications.

The [AD7915/AD7916](#) provide the user with an on-chip track-and-hold amplifier and do not exhibit any pipeline delay or latency, making these devices ideal for multiple multiplexed channel applications.

The [AD7915/AD7916](#) can be interfaced to any 1.8 V to 5 V digital logic family. They are available in a 10-lead MSOP or a tiny 10-lead LFCSP that allows space savings and flexible configurations.

### CONVERTER OPERATION

The [AD7915/AD7916](#) are a successive approximation ADCs based on a charge redistribution digital-to-analog converter (DAC). Figure 28 shows the simplified schematic of the ADC. The capacitive DAC consists of two identical arrays of 18 binary-weighted capacitors, which are connected to the two comparator inputs.

During the acquisition phase, terminals of the array tied to the input of the comparator are connected to GND via SW+ and SW-. All independent switches are connected to the analog inputs. Therefore, the capacitor arrays are used as sampling capacitors and acquire the analog signal on the IN+ and IN- inputs. When the acquisition phase is complete and the CNV input goes high, a conversion phase is initiated.

When the conversion phase begins, SW+ and SW- are opened first. The two capacitor arrays are then disconnected from the inputs and connected to the GND input. Therefore, the differential voltage between the IN+ and IN- inputs captured at the end of the acquisition phase is applied to the comparator inputs, causing the comparator to become unbalanced. By switching each element of the capacitor array between GND and REF, the comparator input varies by binary-weighted voltage steps ( $V_{REF}/2$ ,  $V_{REF}/4$  ...  $V_{REF}/65,536$ ). The control logic toggles these switches, starting with the MSB, to bring the comparator back into a balanced condition. After the completion of this process, the device returns to the acquisition phase, and the control logic generates the ADC output code.

Because the [AD7915/AD7916](#) have an on-board conversion clock, the serial clock, SCK, is not required for the conversion process.

## Transfer Functions

The ideal transfer characteristics for the AD7915/AD7916 are shown in Figure 29 and Table 6.

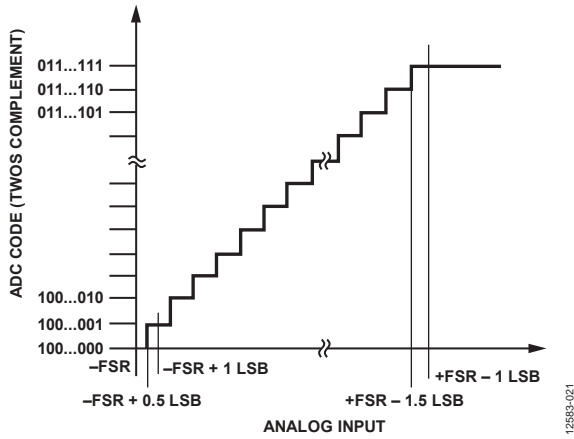

Figure 29. ADC Ideal Transfer Function

Table 6. Output Codes and Ideal Input Voltages

Description	Analog Input $V_{REF} = 5\text{ V}$	Digital Output Code (Hex)
+FSR - 1 LSB	+4.999847 V	0x7FFF <sup>1</sup>
Midscale + 1 LSB	+152.6 $\mu\text{V}$	0x00001
Midscale	0 V	0x00000
Midscale - 1 LSB	-152.6 $\mu\text{V}$	0xFFFF
-FSR + 1 LSB	-4.999847 V	0x8001
-FSR	-5 V	0x8000 <sup>2</sup>

<sup>1</sup> This is also the code for an overranged analog input ( $V_{IN+} - V_{IN-}$  above  $V_{REF} - V_{GND}$ ).  
<sup>2</sup> This is also the code for an underranged analog input ( $V_{IN+} - V_{IN-}$  below  $V_{GND}$ ).

## TYPICAL CONNECTION DIAGRAM

Figure 30 shows an example of the recommended connection diagram for the AD7915/AD7916 when multiple supplies are available.

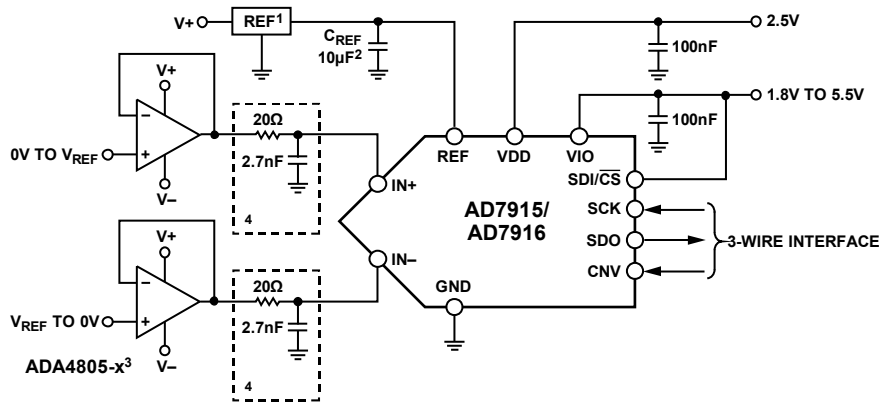

<sup>1</sup>SEE THE VOLTAGE REFERENCE INPUT SECTION FOR REFERENCE SELECTION.

<sup>2</sup> $C_{REF}$  IS USUALLY A 10 $\mu\text{F}$  CERAMIC CAPACITOR (X5R).

<sup>3</sup>SEE THE RECOMMENDED LAYOUT IN FIGURE 49 AND FIGURE 50.

<sup>4</sup>SEE THE DRIVER AMPLIFIER CHOICE SECTION.

<sup>5</sup>OPTIONAL FILTER. SEE THE ANALOG INPUTS SECTION.

Figure 30. Typical Application Diagram with Multiple Supplies

**ANALOG INPUTS**

Figure 31 shows an equivalent circuit of the input structure of the AD7915/AD7916.

The two diodes, D1 and D2, provide ESD protection for the analog inputs, IN+ and IN-. Care must be taken to ensure that the analog input signal does not exceed the reference input voltage (REF) by more than 0.3 V. If the analog input signal exceeds this level, the diodes become forward-biased and start conducting current. These diodes can handle a forward-biased current of 130 mA maximum. However, if the supplies of the input buffer (for example, the supplies of the ADA4805-1 or ADA4805-2, shown as ADA4805-x in Figure 30) are different from those of REF, the analog input signal may eventually exceed the supply rails by more than 0.3 V. In such a case (for example, an input buffer with a short circuit), the current limitation can be used to protect the device.

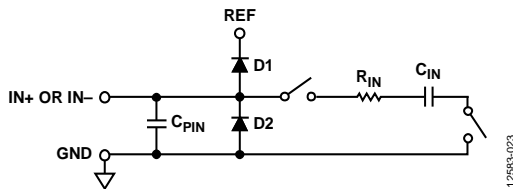

Figure 31. Equivalent Analog Input Circuit

The analog input structure allows the sampling of the true differential signal between IN+ and IN-. By using these differential inputs, signals common to both inputs are rejected.

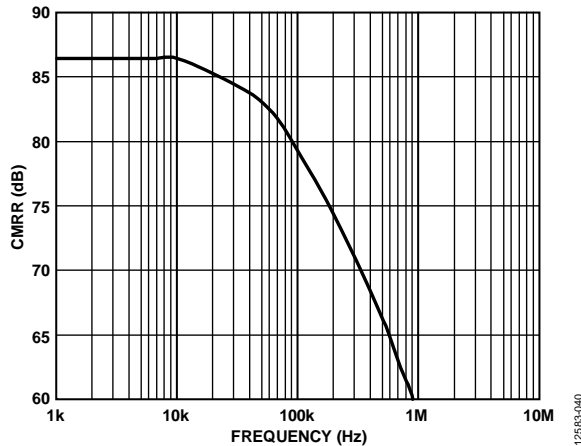

Figure 32. Analog Input CMRR vs. Frequency

During the acquisition phase, the impedance of the analog inputs (IN+ or IN-) can be modeled as a parallel combination of Capacitor C<sub>PIN</sub> and the network formed by the series connection of R<sub>IN</sub> and C<sub>IN</sub>. C<sub>PIN</sub> is primarily the pin capacitance. R<sub>IN</sub> is typically 400 Ω and is a lumped component composed of serial resistors and the on resistance of the switches. C<sub>IN</sub> is typically 30 pF and is mainly the ADC sampling capacitor.

During the sampling phase, when the switches are closed, the input impedance is limited to C<sub>PIN</sub>. R<sub>IN</sub> and C<sub>IN</sub> make a one-pole, low-pass filter that reduces undesirable aliasing effects and limits noise.

When the source impedance of the driving circuit is low, the AD7915/AD7916 can be driven directly. Large source impedances significantly affect the ac performance, especially THD. The dc performances are less sensitive to the input impedance. The maximum source impedance depends on the amount of THD that can be tolerated. The THD degrades as a function of the source impedance and the maximum input frequency.

**DRIVER AMPLIFIER CHOICE**

Although the AD7915/AD7916 are easy to drive, the driver amplifier must meet the following requirements:

- The noise generated by the driver amplifier must be kept as low as possible to preserve the SNR and transition noise performance of the AD7915/AD7916. The noise from the driver is filtered by the one-pole, low-pass filter of the AD7915/AD7916 analog input circuit made by R<sub>IN</sub> and C<sub>IN</sub> or by the external filter, if one is used. Because the typical noise of the AD7915/AD7916 is 60 μV rms, the SNR degradation due to the amplifier is

$$SNR_{LOSS} = 20 \log \left( \frac{60}{\sqrt{60^2 + \frac{\pi}{2} f_{-3dB} (Ne_N)^2}} \right)$$

where:

f<sub>-3dB</sub> is the input bandwidth, in megahertz, of the AD7915/AD7916 (10 MHz) or the cutoff frequency of the input filter, if one is used.

N is the noise gain of the amplifier (for example, 1 in buffer configuration).

e<sub>N</sub> is the equivalent input noise voltage of the op amp, in nV/√Hz.

- For ac applications, use a driver with a THD performance commensurate with the AD7915/AD7916.
- For multichannel, multiplexed applications, the driver amplifier and the AD7915/AD7916 analog input circuit must settle for a full-scale step onto the capacitor array at a 16-bit level (0.0015%, 15 ppm). In the data sheet of the amplifier, settling at 0.1% to 0.01% is more commonly specified. This settling may differ significantly from the settling time at a 16-bit level and must be verified prior to driver selection.

**Table 7. Recommended Driver Amplifiers<sup>1</sup>**

Amplifier	Typical Application
ADA4805-1/ADA4805-2	Very low noise, small, and low power
ADA4940-1	Very low noise, low power, single to differential
ADA4941-1	Very low noise, low power, single to differential
ADA4841-1/ADA4841-2	Very low noise, small, and low power
ADA4897-2	Very low noise and high frequency
AD8655	5 V single supply, low noise
AD8605, AD8615	5 V single supply, low power

<sup>1</sup> For the latest recommended drivers, see the product recommendations listed on the AD7915/AD7916 product webpage.

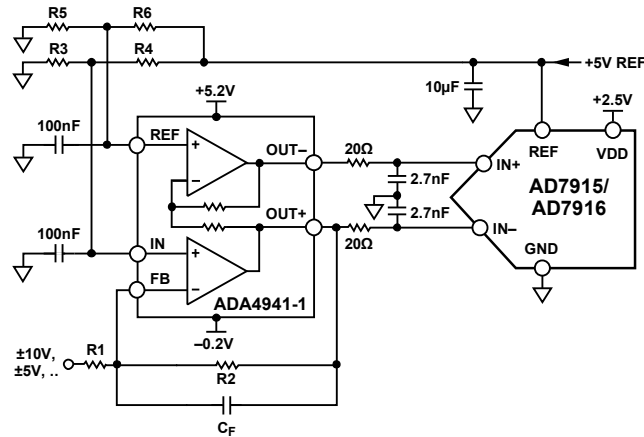

Figure 33. Single-Ended to Differential Driver Circuit

## SINGLE TO DIFFERENTIAL DRIVER

For applications using a single-ended analog signal, either bipolar or unipolar, the [ADA4941-1](#) single-ended to differential driver allows a differential input to the device. The schematic is shown in Figure 33. The [ADA4940-1](#), which is a fully differential amplifier, can be used as a single-ended-to-differential driver as well.

R1 and R2 set the attenuation ratio between the input range and the ADC range ( $V_{REF}$ ). R1, R2, and  $C_F$  are chosen depending on the desired input resistance, signal bandwidth, antialiasing, and noise contribution. For example, for the  $\pm 10$  V range with a 4 k $\Omega$  impedance, R2 = 1 k $\Omega$  and R1 = 4 k $\Omega$ .

R3 and R4 set the common mode on the IN- input, and R5 and R6 set the common mode on the IN+ input of the ADC. Make sure that the common mode is close to  $V_{REF}/2$ . For example, for the  $\pm 10$  V range with a single supply, R3 = 8.45 k $\Omega$ , R4 = 11.8 k $\Omega$ , R5 = 10.5 k $\Omega$ , and R6 = 9.76 k $\Omega$ .

## VOLTAGE REFERENCE INPUT

The [AD7915/AD7916](#) voltage reference input, REF, has a dynamic input impedance and must, therefore, be driven by a low impedance source with efficient decoupling between the REF and GND pins, as explained in the Layout section.

When REF is driven by a very low impedance source (for example, a reference buffer using the [AD8031](#), [ADA4805-1](#) or the [AD8605](#)), a 10  $\mu$ F (X5R, 0805 size) ceramic chip capacitor is appropriate for optimum performance.

If an unbuffered reference voltage is used, the decoupling value depends on the reference used. For instance, a 22  $\mu$ F (X5R, 1206 size) ceramic chip capacitor is appropriate for optimum performance using a low temperature drift [ADR433](#) reference.

If desired, a reference decoupling capacitor with values as small as 2.2  $\mu$ F can be used with a minimal impact on performance, especially DNL.

Regardless, there is no need for an additional lower value ceramic decoupling capacitor (for example, 100 nF) between the REF and GND pins.

## POWER SUPPLY

The [AD7915/AD7916](#) use two power supply pins: a core supply (VDD) and a digital input/output interface supply (VIO). VIO allows direct interface with any logic between 1.8 V and 5.5 V. To reduce the number of supplies needed, VIO and VDD can be tied together. The [AD7915/AD7916](#) are independent of power supply sequencing between VIO and VDD. Additionally, they are insensitive to power supply variations over a wide frequency range, as shown in Figure 34.

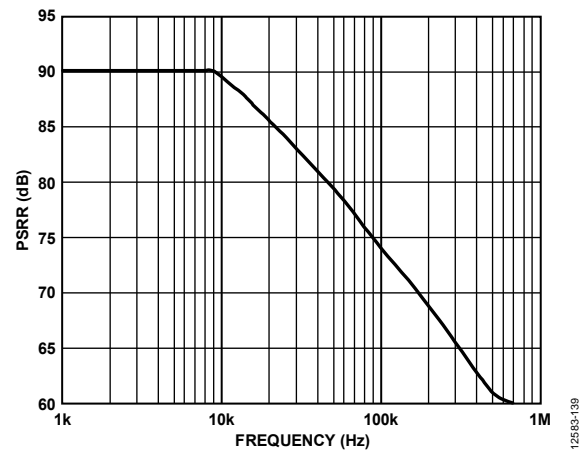

Figure 34. Power Supply Rejection Ratio (PSRR) vs. Frequency

The [AD7915/AD7916](#) power down automatically at the end of each conversion phase.

## DIGITAL INTERFACE

Although the [AD7915/AD7916](#) have a reduced number of pins, they offer flexibility in their serial interface modes.

When in  $\overline{CS}$  mode, the [AD7915/AD7916](#) are compatible with SPI, QSPI™, MIRCROWIRE™, digital hosts, and DSPs. In this mode, the [AD7915/AD7916](#) can use either a 3-wire or 4-wire interface. A 3-wire interface using the CNV, SCK, and SDO signals minimizes wiring connections, which is useful, for instance, in isolated applications. A 4-wire interface using the SDI/ $\overline{CS}$ , CNV, SCK, and SDO signals allows CNV, which initiates the conversions, to be independent of the readback timing (SDI).

This is useful in low jitter sampling or simultaneous sampling applications.

When in chain mode, the AD7915/AD7916 provide a daisy-chain feature using the SDI input for cascading multiple ADCs on a single data line, similar to a shift register.

The mode in which the device operates depends on the SDI/ $\overline{\text{CS}}$  level when the CNV rising edge occurs.  $\overline{\text{CS}}$  mode is selected if SDI/ $\overline{\text{CS}}$  is high, and chain mode is selected if SDI/ $\overline{\text{CS}}$  is low. The SDI/ $\overline{\text{CS}}$  hold time is such that when SDI/ $\overline{\text{CS}}$  and CNV are connected together, chain mode is always selected. In either mode, the AD7915/AD7916 offers the option of forcing a start bit in front of the data bits. This start bit can be used as a busy signal indicator to interrupt the digital host and to trigger the data reading. Otherwise, without a busy indicator, the user must time out the maximum conversion time prior to readback.

The busy indicator feature is enabled

- in  $\overline{\text{CS}}$  mode if CNV or SDI is low when the ADC conversion ends (see Figure 38 and Figure 42).

- in chain mode if  $\overline{\text{SCK}}$  is high during the CNV rising edge (see Figure 46).

**$\overline{\text{CS}}$  MODE, 3-WIRE, WITHOUT BUSY INDICATOR**

This mode is usually used when a single AD7915/AD7916 is connected to an SPI-compatible digital host. The connection diagram is shown in Figure 35, and the corresponding timing is given in Figure 36.

With SDI/ $\overline{\text{CS}}$  tied to VIO, a rising edge on CNV initiates a conversion, selects the  $\overline{\text{CS}}$  mode, and forces SDO to high impedance. When the conversion is complete, the AD7915/AD7916 enter the acquisition phase and power down. When CNV goes low, the MSB is output onto SDO. The remaining data bits are clocked by subsequent SCK falling edges. The data is valid on both SCK edges. Although the rising edge can capture the data, a digital host using the SCK falling edge allows a faster reading rate, provided that it has an acceptable hold time. After the 16<sup>th</sup> SCK falling edge or when CNV goes high (whichever occurs first), SDO returns to high impedance.

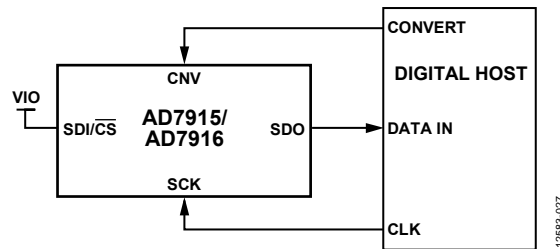

Figure 35.  $\overline{\text{CS}}$  Mode Without Busy Indicator, 3-Wire Connection Diagram (SDI High)

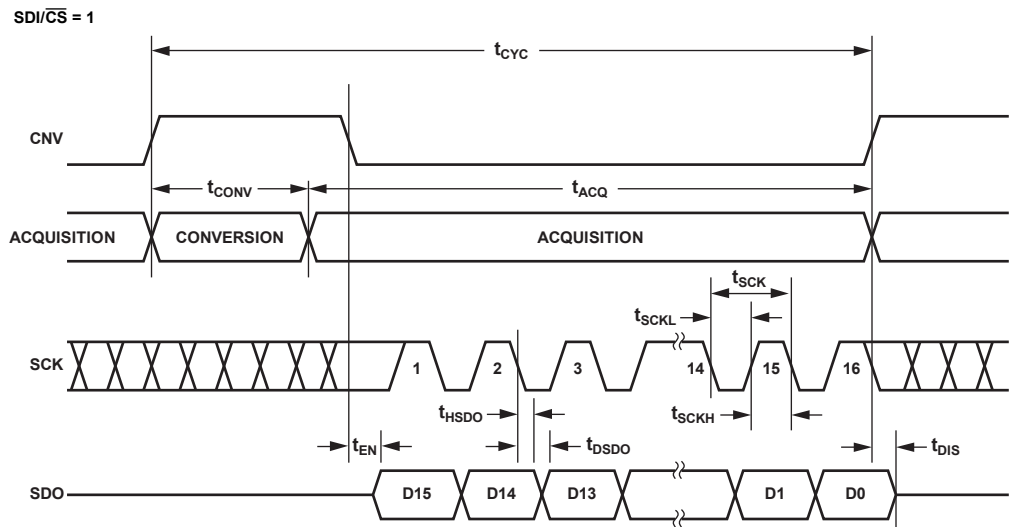

Figure 36.  $\overline{\text{CS}}$  Mode Without Busy Indicator, 3-Wire Serial Interface Timing (SDI High)

**$\overline{\text{CS}}$  MODE 3-WIRE, WITH BUSY INDICATOR**

This mode is typically used when a single AD7915/AD7916 is connected to an SPI-compatible digital host having an interrupt input.

The connection diagram is shown in Figure 37, and the corresponding timing is given in Figure 38.

With SDI tied to VIO, a rising edge on CNV initiates a conversion, selects the  $\overline{\text{CS}}$  mode, and forces SDO to high impedance. SDO is maintained in high impedance until the completion of the conversion irrespective of the state of CNV. Prior to the minimum conversion time, CNV can select other SPI devices, such as analog multiplexers, but CNV must be returned low before the minimum conversion time elapses and then held low for the maximum conversion time to guarantee the generation of the busy signal indicator. When the conversion is complete, SDO goes from high impedance to low. With a pull-up on the SDO line, this transition can be used as an interrupt signal to initiate the data reading controlled by the digital host. The AD7915/AD7916 then enters the acquisition phase and powers down. The data bits are clocked out, MSB first, by subsequent SCK falling edges. The data is valid on both

SCK edges. Although the rising edge can capture the data, a digital host using the SCK falling edge allows a faster reading rate provided it has an acceptable hold time. After the optional 17<sup>th</sup> SCK falling edge, or when CNV goes high (whichever occurs first), SDO returns to high impedance.

If multiple AD7915/AD7916 devices are selected at the same time, the SDO output pin handles this contention without damage or induced latch-up. Meanwhile, it is recommended to keep this contention as short as possible to limit extra power dissipation.

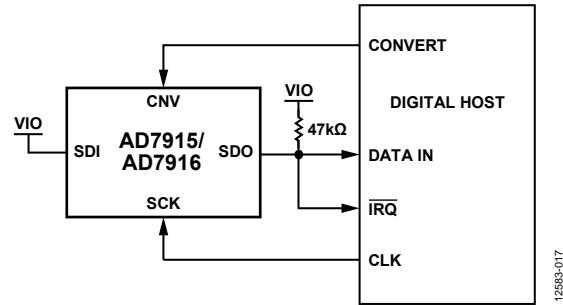

Figure 37. 3-Wire  $\overline{\text{CS}}$  Mode with Busy Indicator Connection Diagram (SDI High)

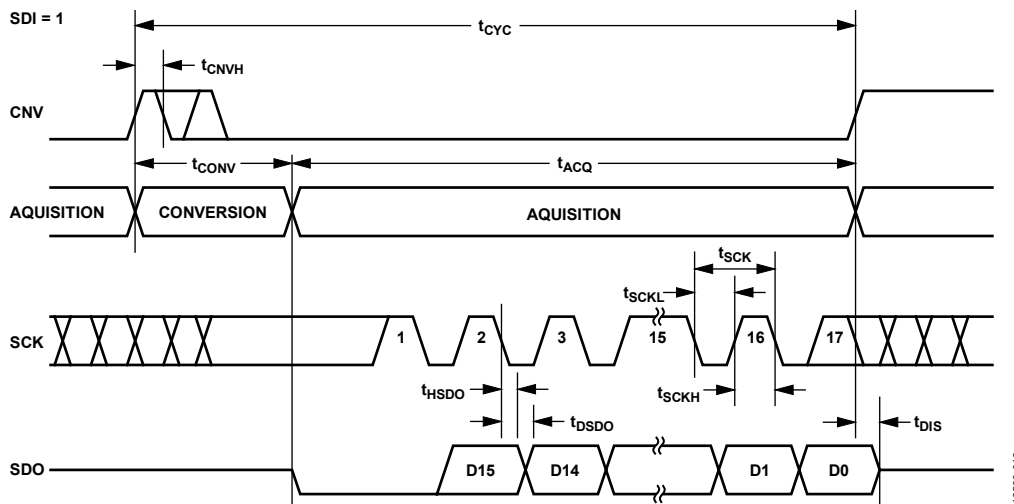

Figure 38. 3-Wire  $\overline{\text{CS}}$  Mode with Busy Indicator Serial Interface Timing (SDI High)

**$\overline{\text{CS}}$  MODE, 4-WIRE, WITHOUT BUSY INDICATOR**

This mode is usually used when multiple AD7915/AD7916 devices are connected to an SPI-compatible digital host.

A connection diagram example using two AD7915/AD7916 devices is shown in Figure 39, and the corresponding timing is given in Figure 40.

With SDI high, a rising edge on CNV initiates a conversion, selects SDI/ $\overline{\text{CS}}$  mode, and forces SDO to high impedance. In this mode, CNV must be held high during the conversion phase and the subsequent data read back; if SDI/ $\overline{\text{CS}}$  and CNV are low, SDO is driven low. Prior to the minimum conversion time, SDI/ $\overline{\text{CS}}$  can be used to select other SPI devices, such as analog multiplexers, but SDI/ $\overline{\text{CS}}$  must be returned high before the

minimum conversion time elapses and then held high for the maximum possible conversion time. When the conversion is complete, the AD7915/AD7916 enter the acquisition phase and power down. Each ADC result can be read by bringing its SDI/ $\overline{\text{CS}}$  input low, which consequently outputs the MSB onto SDO. The remaining data bits are then clocked by subsequent SCK falling edges. The data is valid on both SCK edges. Although the rising edge can be used to capture the data, a digital host using the SCK falling edge allows a faster reading rate, provided that it has an acceptable hold time. After the 16<sup>th</sup> SCK falling edge or when SDI/ $\overline{\text{CS}}$  goes high (whichever occurs first), SDO returns to high impedance and another AD7915/AD7916 can be read.

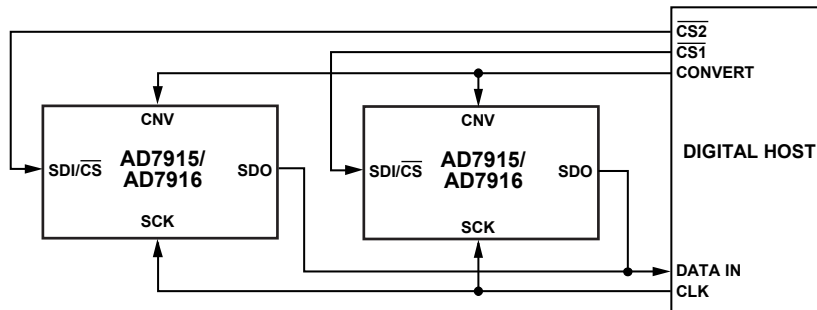

Figure 39.  $\overline{\text{CS}}$  Mode Without Busy Indicator, 4-Wire Connection Diagram

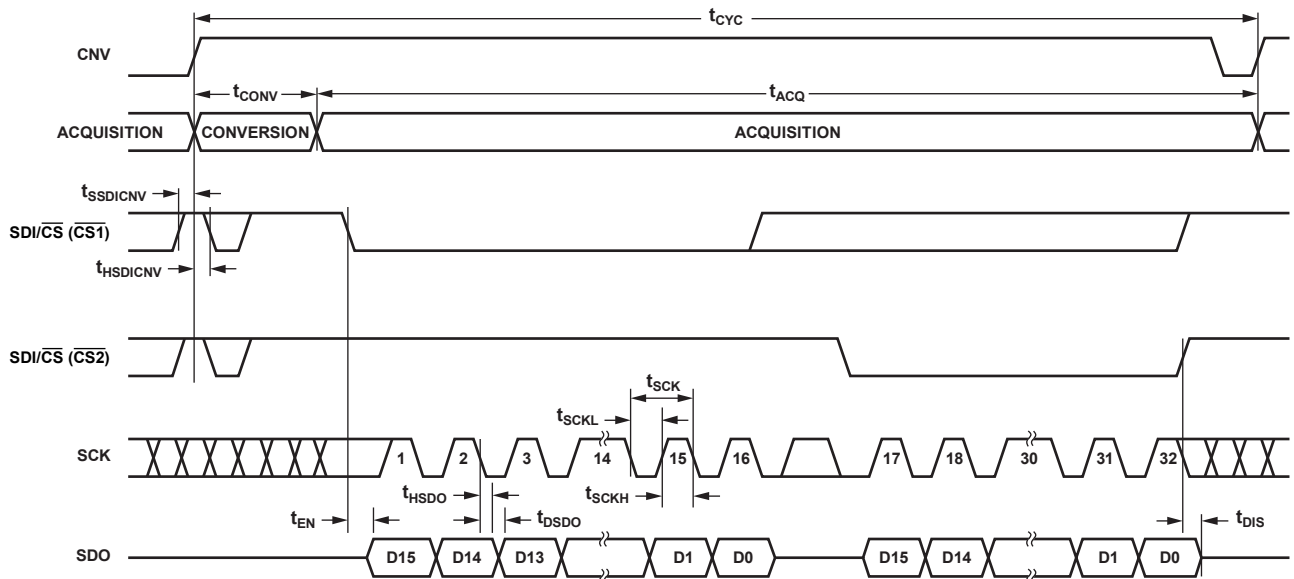

Figure 40.  $\overline{\text{CS}}$  Mode Without Busy Indicator, 4-Wire Serial Interface Timing

**CS MODE 4-WIRE WITH BUSY INDICATOR**

This mode is usually used when a single AD7915/AD7916 is connected to an SPI-compatible digital host that has an interrupt input, and it is desired to keep CNV, which is used to sample the analog input, independent of the signal used to select the data reading. This requirement is particularly important in applications where low jitter on CNV is desired.

The connection diagram is shown in Figure 41, and the corresponding timing is given in Figure 42.

With SDI high, a rising edge on CNV initiates a conversion, selects the CS mode, and forces SDO to high impedance. In this mode, CNV must be held high during the conversion phase and the subsequent data readback (if SDI and CNV are low, SDO is driven low). Prior to the minimum conversion time, SDI can be used to select other SPI devices, such as analog multiplexers, but SDI must be returned low before the minimum conversion time elapses and then held low for the maximum conversion time to guarantee the generation of the busy signal indicator. When the conversion is complete, SDO goes from high impedance to low.

With a pull-up on the SDO line, this transition can be used as an interrupt signal to initiate the data readback controlled by the digital host. The AD7915/AD7916 then enters the acquisition phase and powers down. The data bits are clocked out, MSB first, by subsequent SCK falling edges. The data is valid on both SCK edges. Although the rising edge can be used to capture the data, a digital host using the SCK falling edge allows a faster reading rate provided it has an acceptable hold time. After the optional 17th SCK falling edge or SDI going high, whichever is earlier, the SDO returns to high impedance.

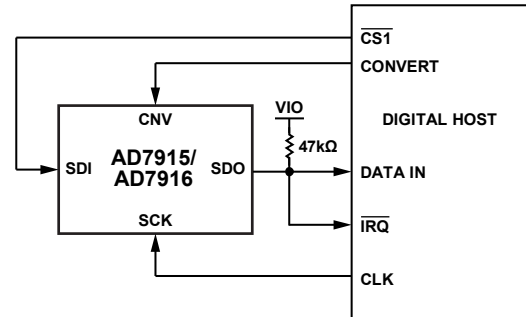

Figure 41. 4-Wire CS Mode with Busy Indicator Connection Diagram

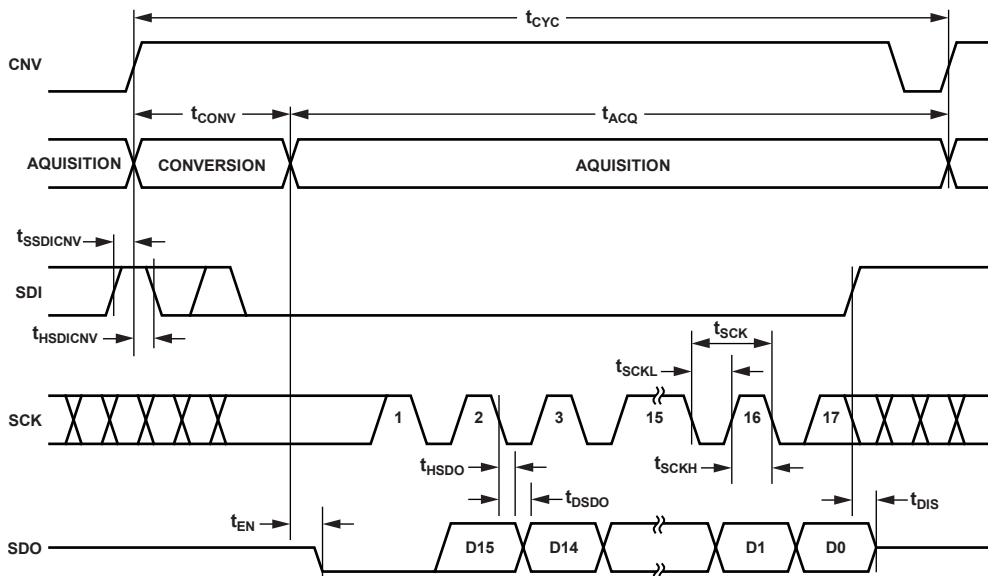

Figure 42. 4-Wire CS Mode with Busy Indicator Serial Interface Timing

**CHAIN MODE, WITHOUT BUSY INDICATOR**

This mode can be used to daisy-chain multiple AD7915/AD7916 devices on a 3-wire serial interface. This feature is useful for reducing component count and wiring connections, for example, in isolated multiconverter applications or for systems with a limited interfacing capacity. Data readback is analogous to clocking a shift register.

A connection diagram example using two AD7915/AD7916 devices is shown in Figure 43, and the corresponding timing is given in Figure 44.

When SDI/CS and CNV are low, SDO is driven low. With SCK low, a rising edge on CNV initiates a conversion, and selects the chain mode. In this mode, CNV is held high during the

conversion phase and the subsequent data readback. When the conversion is complete, the MSB is output onto SDO and the AD7915/AD7916 enter the acquisition phase and power down. The remaining data bits stored in the internal shift register are clocked by subsequent SCK falling edges. For each ADC, SDI feeds the input of the internal shift register and is clocked by the SCK falling edge. Each ADC in the chain outputs its data MSB first, and  $16 \times N$  clocks are required to read back the N ADCs. The data is valid on both SCK edges. Although the rising edge can be used to capture the data, a digital host using the SCK falling edge allows a faster reading rate and, consequently, more AD7915/AD7916 devices in the chain, provided that the digital host has an acceptable hold time. The maximum conversion rate may be reduced due to the total readback time.

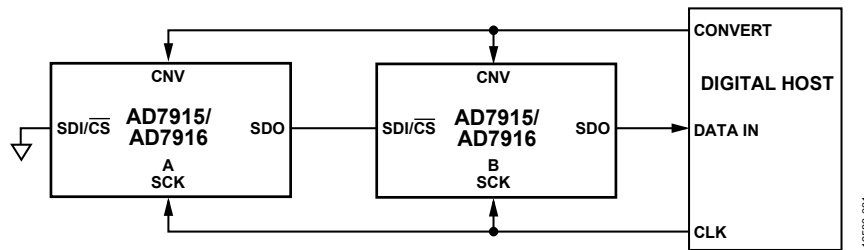

Figure 43. Chain Mode Without Busy Indicator Connection Diagram

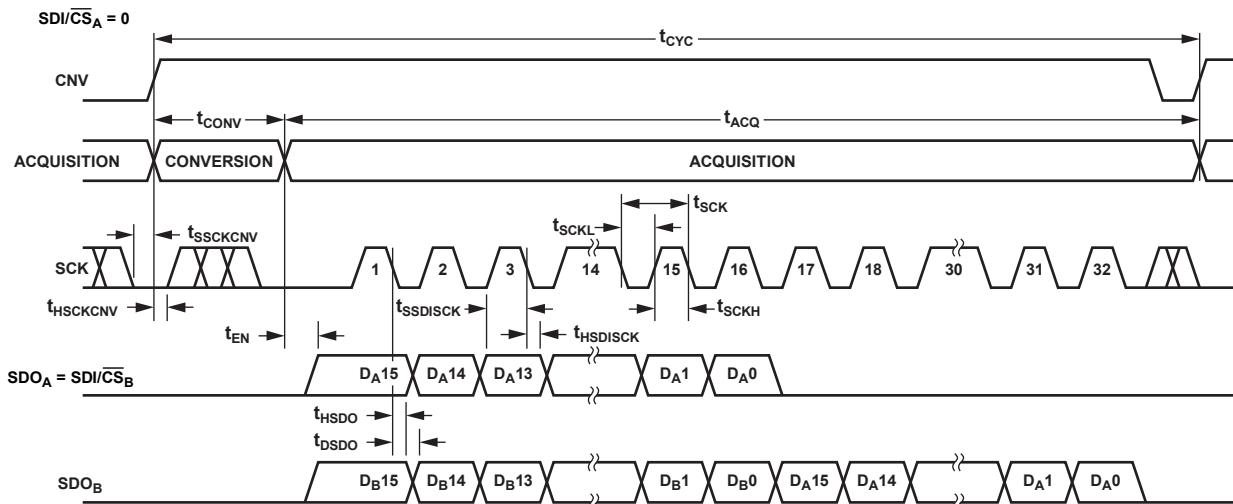

Figure 44. Chain Mode Without Busy Indicator Serial Interface Timing

**CHAIN MODE WITH BUSY INDICATOR**

This mode can also be used to daisy-chain multiple AD7915/AD7916 devices on a 3-wire serial interface while providing a busy indicator. This feature is useful for reducing component count and wiring connections, for example, in isolated multi-converter applications or for systems with a limited interfacing capacity. Data readback is analogous to clocking a shift register.

A connection diagram example using three AD7915/AD7916 devices is shown in Figure 45, and the corresponding timing is given in Figure 46.

When SDI and CNV are low, SDO is driven low. With SCK high, a rising edge on CNV initiates a conversion, selects the chain mode, and enables the busy indicator feature. In this mode, CNV is held high during the conversion phase and the subsequent data readback. When all ADCs in the chain have

completed their conversions, the SDO pin of the ADC closest to the digital host (see the AD7915/AD7916 ADC labeled C in Figure 45) is driven high. This transition on SDO can be used as a busy indicator to trigger the data readback controlled by the digital host. The AD7915/AD7916 then enter the acquisition phase and powers down. The data bits stored in the internal shift register are clocked out, MSB first, by subsequent SCK falling edges. For each ADC, SDI feeds the input of the internal shift register and is clocked by the SCK falling edge. Each ADC in the chain outputs its data MSB first, and  $16 \times N + 1$  clocks are required to readback the N ADCs. Although the rising edge can be used to capture the data, a digital host using the SCK falling edge allows a faster reading rate and, consequently, more AD7915/AD7916 devices in the chain, provided that the digital host has an acceptable hold time.

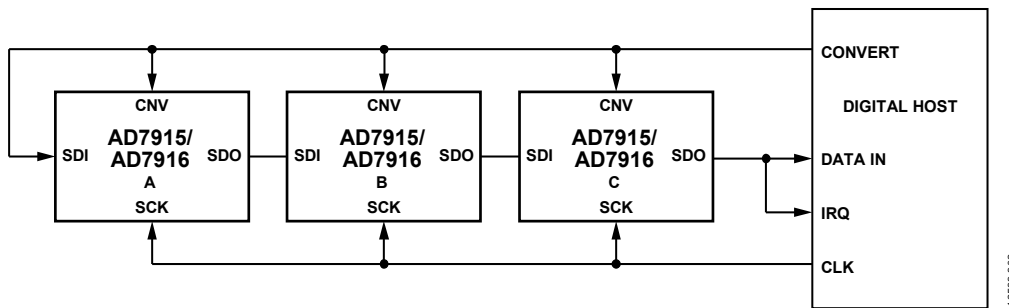

Figure 45. Chain Mode with Busy Indicator Connection Diagram

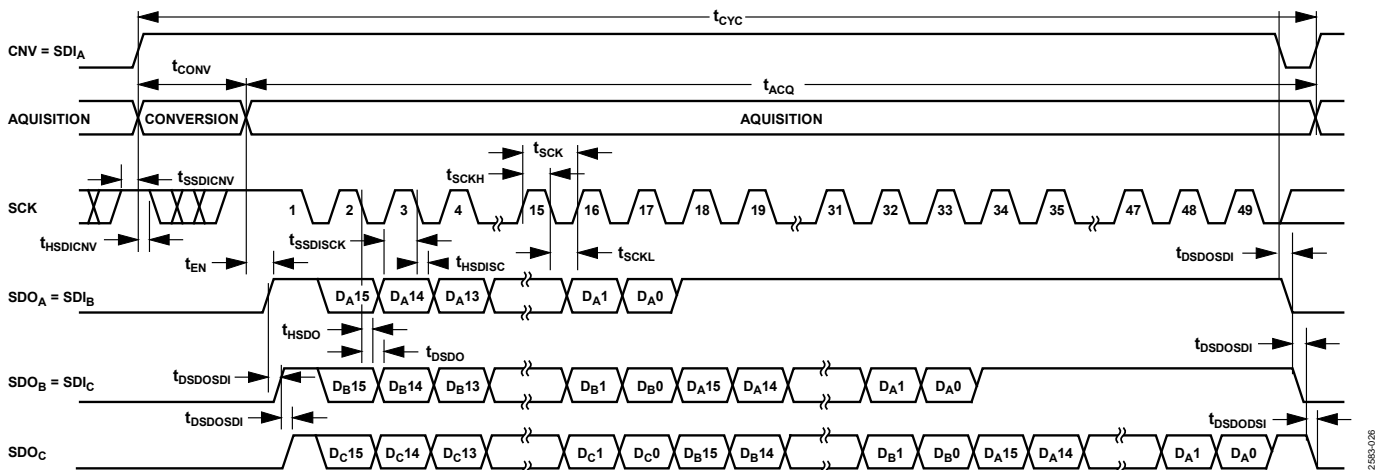

Figure 46. Chain Mode with Busy Indicator Serial Interface Timing

## APPLICATIONS INFORMATION

### INTERFACING TO BLACKFIN DSP

The AD7915/AD7916 can easily connect to a Blackfin® DSP SPI or SPORT. The SPI configuration is straightforward using the standard SPI interface, as shown in Figure 47.

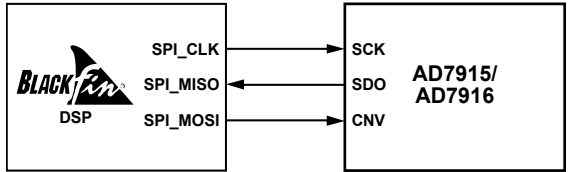

Figure 47. Typical Connection to Blackfin SPI Interface

Similarly, the SPORT interface can be used to interface to this ADC. The SPORT interface has some benefits in that it can use direct memory access (DMA) and provides a lower jitter CNV signal generated from a hardware counter.

Some glue logic may be required between SPORT and the AD7915/AD7916 interface. The evaluation board for the AD7915/AD7916 interfaces directly to the SPORT of the Blackfin-based (ADSP-BF527) SDP board. The configuration used for the SPORT interface requires the addition of some glue logic as shown in Figure 48. The SCK input to the ADC was gated off when CNV was high to keep the SCK line static while converting the data, thereby ensuring the best integrity of the result. This approach uses an AND gate and a NOT gate for the SCK path. The other logic gates used on the RSCLK and RFS paths are for delay matching purposes and may not be necessary when path lengths are short.

This is one approach to using the SPORT interface for this ADC; there may be other solutions similar to this approach.

### LAYOUT

Design the printed circuit board that houses the AD7915/AD7916 so that the analog and digital sections are separated and confined to certain areas of the board. The pinout of the AD7915/AD7916, with its analog signals on the left side and its digital signals on the right side, eases this task.

Avoid running digital lines under the device because these couple noise onto the die, unless a ground plane under the AD7915/AD7916 is used as a shield. Do not run fast switching signals, such as CNV or clocks, near analog signal paths. Avoid crossover of digital and analog signals.

Using at least one ground plane is recommended. It can be common or split between the digital and analog sections. In the latter case, join the planes underneath the AD7915/AD7916 devices.

The AD7915/AD7916 voltage reference input, REF, has a dynamic input impedance. Decouple REF with minimal parasitic inductances by placing the reference decoupling ceramic capacitor close to, but ideally right up against, the REF and GND pins and connecting them with wide, low impedance traces.

Finally, decouple the power supplies of the AD7915/AD7916, VDD and VIO, with ceramic capacitors, typically 100 nF, placed close to the AD7915/AD7916 and connected using short, wide traces to provide low impedance paths and to reduce the effect of glitches on the power supply lines.

An example of a layout following these rules is shown in Figure 49 and Figure 50.

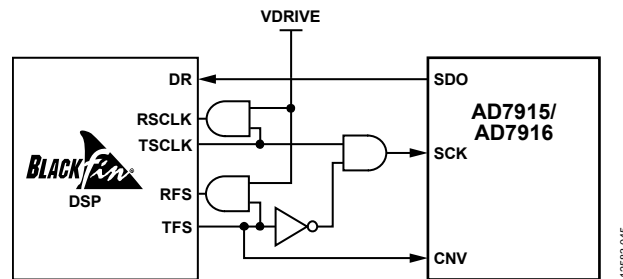

Figure 48. Evaluation Board Connection to Blackfin Sport Interface

**EVALUATING AD7915/AD7916 PERFORMANCE**

Other recommended layouts for the AD7915/AD7916 are outlined in UG-340, the user guide of the evaluation board for the AD7915/AD7916 (EVAL-AD7915SDZ/EVAL-AD7916SDZ). The evaluation board package includes a fully assembled and tested evaluation board, the user guide, and software for controlling the board from a PC via the EVAL-SDP-CB1Z.

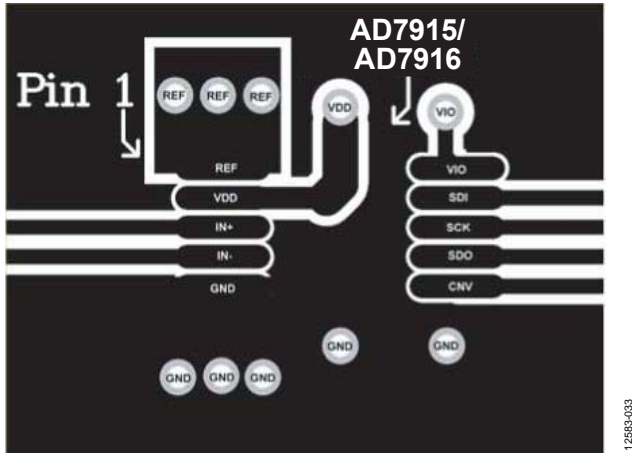

Figure 49. Recommended Layout of the AD7915/AD7916 (Top Layer)

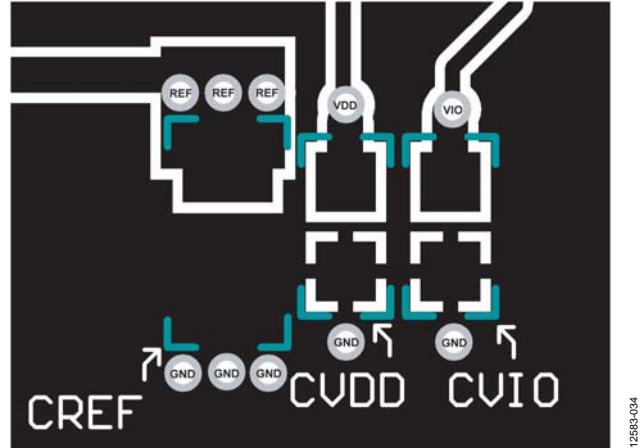
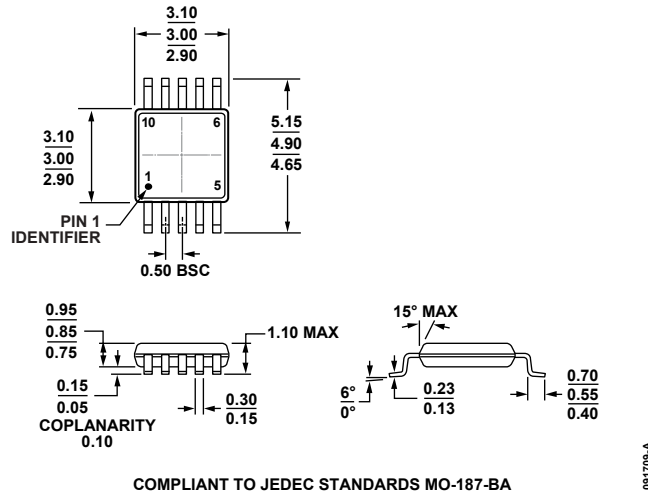

Figure 50. Recommended Layout of the AD7915/AD7916 (Bottom Layer)

# OUTLINE DIMENSIONS



COMPLIANT TO JEDEC STANDARDS MO-187-BA  
 Figure 51. 10-Lead Mini Small Outline Package [MSOP]  
 (RM-10)  
 Dimensions shown in millimeters

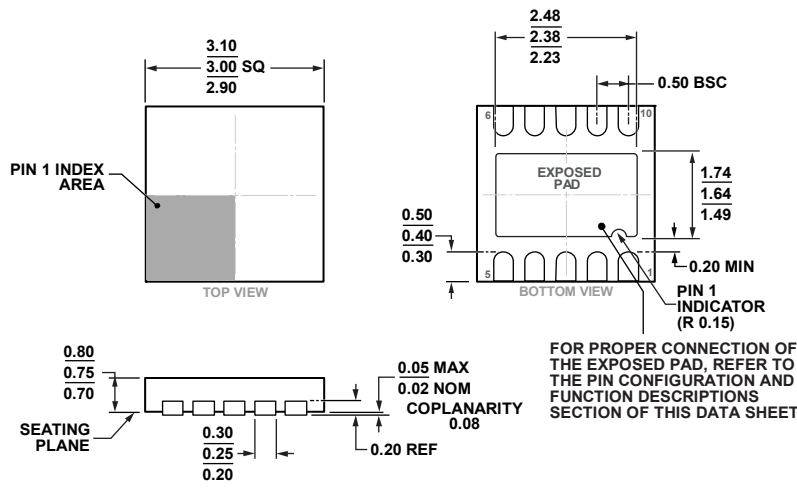

Figure 52. 10-Lead Lead Frame Chip Scale Package [LFCSP\_WD]  
 3 mm x 3 mm Body, Very Very Thin, Dual Lead (CP-10-9)  
 Dimensions shown in millimeters

## ORDERING GUIDE

Model <sup>1, 2, 3</sup>	Temperature Range	Package Description	Package Option	Ordering Quantity	Branding
AD7915BRMZ	-40°C to +125°C	10-Lead MSOP, Tube	RM-10	50	C85
AD7915BRMZ-RL7	-40°C to +125°C	10-Lead MSOP, 7" Tape and Reel	RM-10	1,000	C85
AD7915BCPZ-RL7	-40°C to +125°C	10-Lead LFCSP_WD, 7" Tape and Reel	CP-10-9	1,500	C87
AD7916BRMZ	-40°C to +125°C	10-Lead MSOP, Tube	RM-10	50	C86
AD7916BRMZ-RL7	-40°C to +125°C	10-Lead MSOP, 7" Tape and Reel	RM-10	1,000	C86
AD7916BCPZ-RL7	-40°C to +125°C	10-Lead LFCSP_WD, 7" Tape and Reel	CP-10-9	1,500	C87
EVAL-AD7915SDZ		Evaluation Board			
EVAL-AD7916SDZ		Evaluation Board			
EVAL-SDP-CB1Z		System Demonstration Board, Used as a Controller Board for Data Transfer via a USB Interface to PC			

<sup>1</sup> Z = RoHS Compliant Part.

<sup>2</sup> The EVAL-AD7915DZ and EVAL-AD7916SDZ boards can be used as standalone evaluation boards, or in conjunction with the EVAL-SDP-CB1Z for evaluation and demonstration purposes.

<sup>3</sup> The EVAL-SDP-CB1Z board allows a PC to control and communicate with all Analog Devices, Inc., evaluation boards ending in the SD designator.

**NOTES**

## Looking for pricing, stock, or lifecycle information?

Click below to explore more details on WIN SOURCE:

 [View AD7916BRMZ on WIN SOURCE](#)

 [Analog Devices Inc. Information](#)

## Optimize Your Supply Chain with WIN SOURCE Solutions

-  Global Sourcing Solution
-  Obsolete Management
-  Cost Control Management
-  Shortage Management
-  Alternative Solution
-  Excess Inventory Management