

PIC32 Flash Programming Specification

1.0 DEVICE OVERVIEW

This document defines the Flash programming specification for the PIC32 family of 32-bit microcontrollers.

This programming specification is designed to guide developers of external programmer tools. Customers who are developing applications for PIC32 devices should use development tools that already provide support for device programming.

The major topics of discussion include:

- [Section 1.0 “Device Overview”](#)
- [Section 2.0 “Programming Overview”](#)
- [Section 3.0 “Programming Steps”](#)
- [Section 4.0 “Connecting to the Device”](#)
- [Section 5.0 “EJTAG vs. ICSP”](#)
- [Section 6.0 “Pseudo Operations”](#)
- [Section 7.0 “Entering 2-Wire Enhanced ICSP Mode”](#)
- [Section 8.0 “Check Device Status”](#)
- [Section 9.0 “Erasing the Device”](#)
- [Section 10.0 “Entering Serial Execution Mode”](#)
- [Section 11.0 “Downloading the Programming Executive \(PE\)”](#)
- [Section 12.0 “Downloading a Data Block”](#)
- [Section 13.0 “Initiating a Page Erase”](#)
- [Section 14.0 “Initiating a Flash Row Write”](#)
- [Section “”](#)
- [Section 16.0 “Exiting Programming Mode”](#)
- [Section 17.0 “The Programming Executive”](#)
- [Section 18.0 “Checksum”](#)
- [Section 19.0 “Configuration Memory and Device ID”](#)
- [Section 20.0 “TAP Controllers”](#)
- [Section 21.0 “AC/DC Characteristics and Timing Requirements”](#)
- [Appendix A: “PIC32 Flash Memory Map”](#)
- [Appendix B: “Hex File Format”](#)
- [Appendix C: “Device IDs”](#)
- [Appendix D: “Revision History”](#)

2.0 PROGRAMMING OVERVIEW

When in development of a programming tool, it is necessary to understand the internal Flash program operations of the target device and the Special Function Registers (SFRs) used to control Flash programming, as these same operations and registers are used by an external programming tool and its software. These operations and control registers are described in the “**Flash Program Memory**” chapter in the specific device data sheet, and the related “*PIC32 Family Reference Manual*” section. It is highly recommended that these documents be used in conjunction with this programming specification.

An external tool programming setup consists of an external programmer tool and a target PIC32 device. [Figure 2-1](#) illustrates a typical programming setup. The programmer tool is responsible for executing necessary programming steps and completing the programming operation.

FIGURE 2-1: PROGRAMMING SYSTEM SETUP

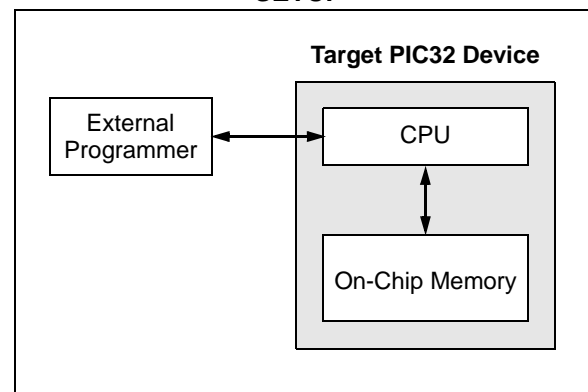

PIC32

2.1 Devices with Dual Flash Panel and Dual Boot Regions

The PIC32MKXXXXXXD/E/F/K/L/M and PIC32MZ families of devices incorporate several features useful for field (self) programming of the device. These features include dual Flash panels with dual boot regions, an aliasing scheme for the boot regions allowing automatic selection of boot code at start-up and a panel swap feature for Program Flash. The two Flash panels and their associated boot regions can be erased and programmed separately. Refer to the **Section 48. “Memory Organization and Permissions”** (DS60001214) of the *“PIC32 Family Reference Manual”* for a detailed explanation of these features.

A development tool used for production programming will not be concerned about most of these features with the following exceptions:

- Ensuring the SWAP bit (NVMCON<7>) is in the proper setting. The default setting is ‘0’ for no swap of panels. The development tool should assume the default setting when generating source files for the programming tool.
- Proper handling of the aliasing of the boot memory in the checksum calculation. The aliased sections will be duplicates of the fixed sections. See **Section 18.0 “Checksum”** for more information on checksum calculations with aliased regions
- For PIC32MK devices, using the Erase/Retry feature when an attempt to erase a Flash page fails and needs to be retried. See **Section 13.0 “Initiating a Page Erase”** for more information.

2.2 Programming Interfaces

All PIC32 devices provide two physical interfaces to the external programmer tool:

- 2-wire In-Circuit Serial Programming™ (ICSP™)
- 4-wire Joint Test Action Group (JTAG)

See **Section 4.0 “Connecting to the Device”** for more information.

Either of these methods may use a downloadable Programming Executive (PE). The PE executes from the target device RAM and hides device programming details from the programmer. It also removes overhead associated with data transfer and improves overall data throughput. Microchip has developed a PE that is available for use with any external programmer, see **Section 17.0 “The Programming Executive”** for more information.

Section 3.0 “Programming Steps” describes high-level programming steps, followed by a brief explanation of each step. Detailed explanations are available in corresponding sections of this document.

More information on programming commands, EJTAG, and DC specifications are available in the following sections:

- **Section 19.0 “Configuration Memory and Device ID”**
- **Section 20.0 “TAP Controllers”**
- **Section 21.0 “AC/DC Characteristics and Timing Requirements”**

2.3 Enhanced JTAG (EJTAG)

The 2-wire and 4-wire interfaces use the EJTAG protocol to exchange data with the programmer. While this document provides a working description of this protocol as needed, advanced users are advised to refer to the Imagination Technologies Limited web site (www.imgtec.com) for more information.

2.4 Data Sizes

Data sizes are defined as follows:

- One word: 32 bits
- One-half word: 16 bits
- One-quarter word: 8 bits
- One Byte: 8 bits

3.0 PROGRAMMING STEPS

All tool programmers must perform a common set of steps, regardless of the actual method being used. [Figure 3-1](#) shows the set of steps to program PIC32 devices.

FIGURE 3-1: PROGRAMMING FLOW

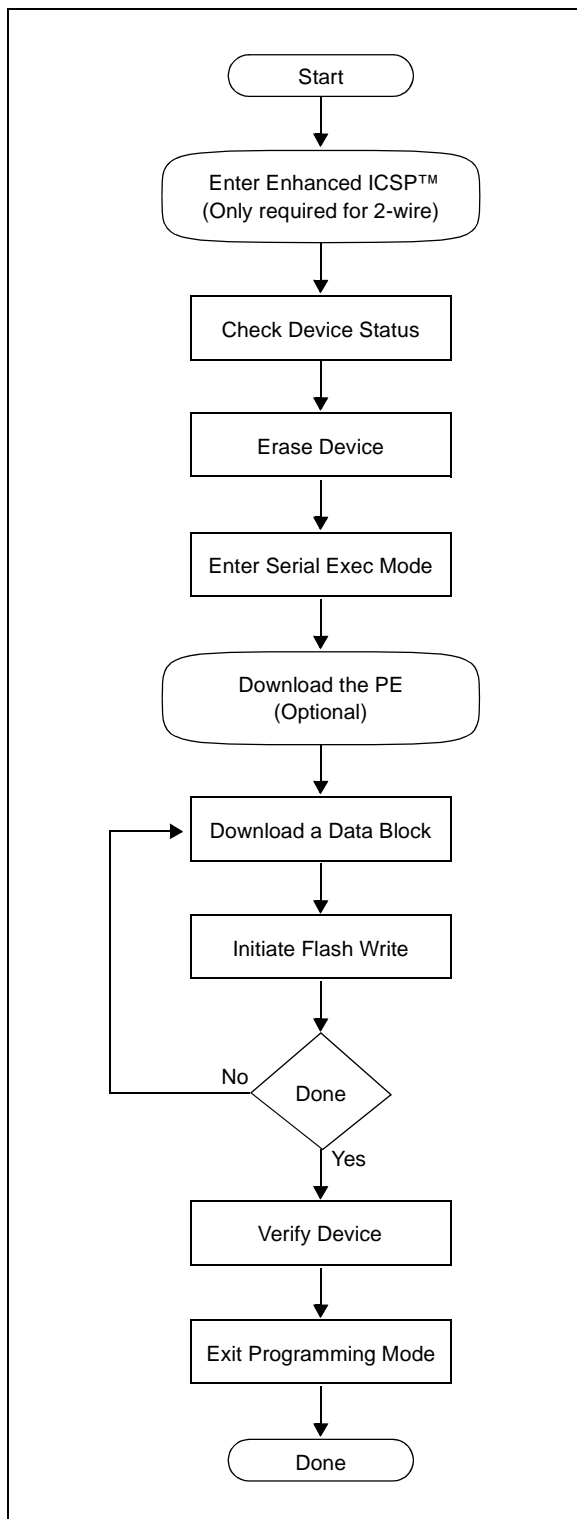

The following sequence lists the programming steps with a brief explanation of each step. More detailed information about these steps is available in the subsequent sections.

1. Connect to the target device.
To ensure successful programming, all required pins must be connected to appropriate signals. See [Section 4.0 “Connecting to the Device”](#) for more information.
2. Place the target device in programming mode.
For 2-wire programming methods, the target device must be placed in a special programming mode (Enhanced ICSP™) before executing any other steps.

Note: For the 4-wire programming methods, Step 2 is not applicable.

3. Check the status of the device.
Checks the status of the device to ensure it is ready to receive information from the programmer.
See [Section 8.0 “Check Device Status”](#) for more information.
4. Erase the target device.
If the target memory block in the device is not blank, or if the device is code-protected, an erase step must be performed before programming any new data.
See [Section 9.0 “Erasing the Device”](#) for more information.
5. Enter programming mode.
Verifies that the device is not code-protected and boots the TAP controller to start sending and receiving data to and from the PIC32 CPU.
See [Section 10.0 “Entering Serial Execution Mode”](#) for more information.

PIC32

6. Download the Programming Executive (PE).

The PE is a small block of executable code that is downloaded into the RAM of the target device. It will receive and program the actual data.

Note: If the programming method being used does not require the PE, Step 6 is not applicable.

See [Section 11.0 “Downloading the Programming Executive \(PE\)”](#) for more information.

7. Download the block of data to program.

All methods, with or without the PE, must download the desired programming data into a block of memory in RAM.

See [Section 12.0 “Downloading a Data Block”](#) for more information.

8. Initiate Flash Write.

After downloading each block of data into RAM, the programming sequence must be started to program it into the target device's Flash memory.

See [Section 14.0 “Initiating a Flash Row Write”](#) for more information.

9. Repeat Step 7 and Step 8 until all data blocks are downloaded and programmed.

10. Verify the program memory.

After all programming data and Configuration bits are programmed, the target device memory should be read back and verified for the matching content.

See [Section “”](#) for more information.

11. Exit the programming mode.

The newly programmed data is not effective until either power is removed and reapplied to the target device or an exit programming sequence is performed.

See [Section 16.0 “Exiting Programming Mode”](#) for more information.

4.0 CONNECTING TO THE DEVICE

The PIC32 family provides two possible physical interfaces for connecting and programming the memory contents, see [Figure 4-1](#). For all programming interfaces, the target device must be powered and all required signals must be connected. In addition, the interface must be enabled, either through its Configuration bit, as in the case of the JTAG 4-wire interface, or through a special initialization sequence, as is the case for the 2-wire ICSP interface.

The JTAG interface is enabled by default in blank devices shipped from the factory.

Enabling ICSP is described in [Section 7.0 “Entering 2-Wire Enhanced ICSP Mode”](#).

FIGURE 4-1: PROGRAMMING INTERFACES

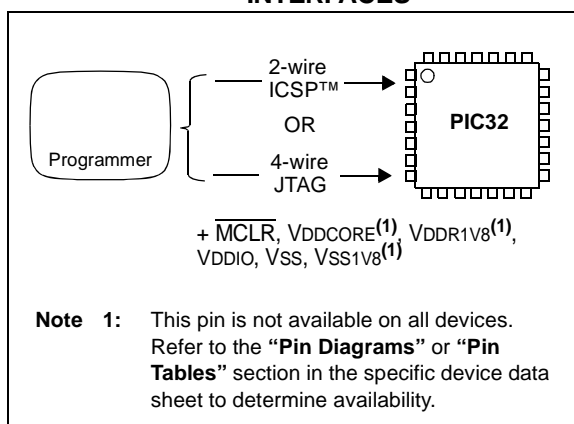

4.1 4-wire Interface

One possible interface is the 4-wire JTAG (IEEE 1149.1) port. [Table 4-1](#) lists the required pin connections. This interface uses the following four communication lines to transfer data to and from the PIC32 device being programmed:

- Test Clock Input (TCK)
- Test Mode Select Input (TMS)
- Test Data Input (TDI)
- Test Data Output (TDO)

Refer to the specific device data sheet for the connection of the signals to the device pins.

4.1.1 TEST CLOCK INPUT (TCK)

TCK is the clock that controls the updating of the TAP controller and the shifting of data through the Instruction or selected Data registers. TCK is independent of the processor clock with respect to both frequency and phase.

4.1.2 TEST MODE SELECT INPUT (TMS)

TMS is the control signal for the TAP controller. This signal is sampled on the rising edge of TCK.

4.1.3 TEST DATA INPUT (TDI)

TDI is the test data input to the Instruction or selected Data register. This signal is sampled on the rising edge of TCK for some TAP controller states.

4.1.4 TEST DATA OUTPUT (TDO)

TDO is the test data output from the Instruction or Data registers. This signal changes on the falling edge of TCK. TDO is only driven when data is shifted out, otherwise the TDO is tri-stated.

TABLE 4-1: 4-WIRE INTERFACE PINS

Device Pin Name	Pin Type	Pin Description
MCLR	I	Programming Enable
ENVREG ⁽²⁾	I	Enable for On-Chip Voltage Regulator
VDD, VDDIO, VDDCORE ⁽²⁾ , VDDR1V8 ⁽²⁾ , VBAT ⁽²⁾ , and AVDD ⁽¹⁾	P	Power Supply
VSS, VSS1V8 ⁽²⁾ , and AVSS ⁽¹⁾	P	Ground
VCAP ⁽²⁾	P	CPU logic filter capacitor connection
TDI	I	Test Data In
TDO	O	Test Data Out
TCK	I	Test Clock
TMS	I	Test Mode State

Legend: I = Input O = Output P = Power

- Note 1:** All power supply and ground pins must be connected, including analog supplies (AVDD) and ground (AVSS).
2: This pin is not available on all devices. Refer to the “Pin Diagrams” or “Pin Tables” section in the specific device data sheet to determine availability.

PIC32

4.2 2-wire Interface

Another possible interface is the 2-wire ICSP port. Table 4-2 lists the required pin connections. This interface uses the following two communication lines to transfer data to and from the PIC32 device being programmed:

- Serial Program Clock (PGECx)
- Serial Program Data (PGEDx)

These signals are described in the following two sections. Refer to the specific device data sheet for the connection of the signals to the chip pins.

4.2.1 SERIAL PROGRAM CLOCK (PGECx)

PGECx is the clock that controls the updating of the TAP controller and the shifting of data through the Instruction or selected Data registers. PGECx is independent of the processor clock, with respect to both frequency and phase.

4.2.2 SERIAL PROGRAM DATA (PGEDx)

PGEDx is the data input/output to the Instruction or selected Data Registers, it is also the control signal for the TAP controller. This signal is sampled on the falling edge of PGECx for some TAP controller states.

TABLE 4-2: 2-WIRE INTERFACE PINS

Device Pin Name	Programmer Pin Name	Pin Type	Pin Description
MCLR	MCLR	P	Programming Enable
ENVREG ⁽²⁾	N/A	I	Enable for On-Chip Voltage Regulator
VDD, VDDIO, VBAT ⁽²⁾ , and AVDD ⁽¹⁾	VDD	P	Power Supply
VDDCORE ⁽²⁾ and VDDR1V8 ⁽²⁾	N/A	P	Power Supply for DDR Interface
VSS, VSS1V8 ⁽²⁾ , and AVSS ⁽¹⁾	VSS	P	Ground
VCAP ⁽²⁾	N/A	P	CPU Logic Filter Capacitor Connection
PGECx	PGEC	I	Primary Programming Pin Pair: Serial Clock
PGEDx	PGED	I/O	Primary Programming Pin Pair: Serial Data

Legend: I = Input O = Output P = Power

Note 1: All power supply and ground pins must be connected, including analog supplies (AVDD) and ground (AVSS).

2: This pin is not available on all devices. Refer to either the “Pin Diagrams” or “Pin Tables” section in the specific device data sheet to determine availability.

4.3 PIC32MX Power Requirements

Devices in the PIC32MX family are dual voltage supply designs. There is one supply for the core and another for peripherals and I/O pins. All devices contain an on-chip regulator for the lower voltage core supply to eliminate the need for an additional external regulator. There are three implementations of the on board regulator:

- The first version has an internal regulator that can be disabled using the ENVREG pin. When disabled, an external power supply must be used to power the core. If enabled, a low-ESR filter capacitor must be connected to the VCAP pin, see [Figure 4-2](#).
- The second version has an internal regulator that cannot be disabled. A low-ESR filter capacitor must always be connected to the VCAP pin.
- The third version has an internal regulator that cannot be disabled and does not require a filter capacitor

Refer to [Section 21.0 “AC/DC Characteristics and Timing Requirements”](#) and the “[Electrical Characteristics](#)” chapter in the specific device data sheet for the power requirements for your device.

FIGURE 4-2: INTERNAL REGULATOR ENABLE/DISABLE OPTIONS

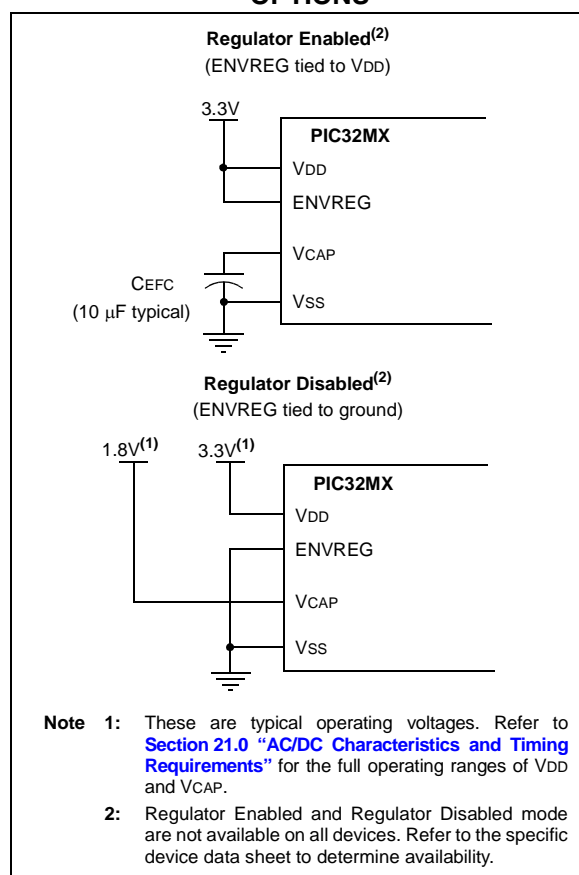

4.4 PIC32MX With VBAT Pin Power Requirements

Some devices in the PIC32MX family provide a VBAT pin which can be connected to the VDD power supply during programming. See [Figure 4-3](#).

FIGURE 4-3: PIC32MX WITH VBAT PIN POWER CONNECTIONS

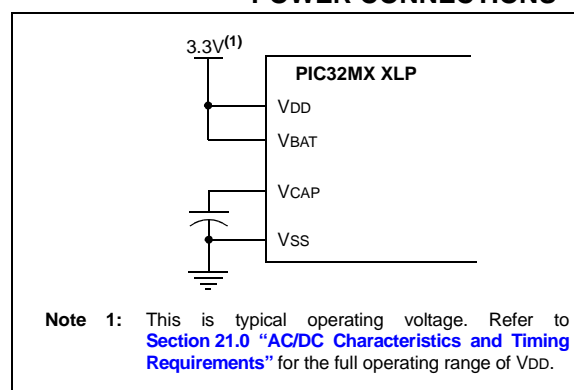

4.5 PIC32MZ EC and PIC32MZ EF Power Requirements

Devices in the PIC32MZ EC and PIC32MZ EF families are also dual voltage supply designs like PIC32MX devices. However, the internal regulator does not require the external filter capacitor, and there is no corresponding VCAP or ENVREG pins. See [Figure 4-4](#).

Refer to [Section 21.0 “AC/DC Characteristics and Timing Requirements”](#) and the “[Electrical Characteristics](#)” chapter in the specific device data sheet for the power requirements for your device.

FIGURE 4-4: PIC32MZ EC/EF POWER CONNECTIONS

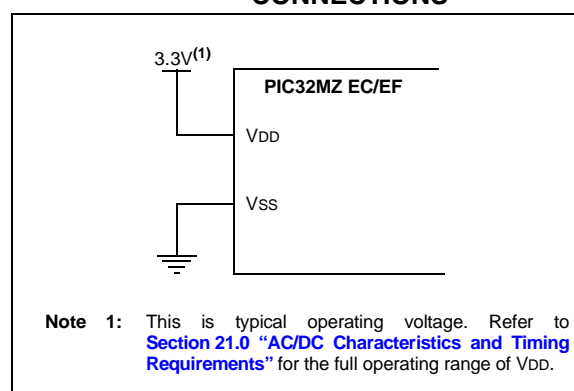

PIC32

4.6 PIC32MZ DA Power Requirements

Devices in the PIC32MZ DA family are quadruple voltage supply designs. Two of the voltage supplies are identical to the PIC32MZ EC and PIC32MZ EF voltage supplies. The third voltage supply is for the DDR memory interface, and requires a 1.8 volt supply. The fourth voltage supply is for the VBAT pin, but it can be connected to the VDD power supply. See [Figure 4-5](#).

Refer to [Section 21.0 “AC/DC Characteristics and Timing Requirements”](#) and the “[Electrical Characteristics](#)” chapter in the specific device data sheet for the power requirements for your device.

FIGURE 4-5: PIC32MZ DA POWER CONNECTIONS

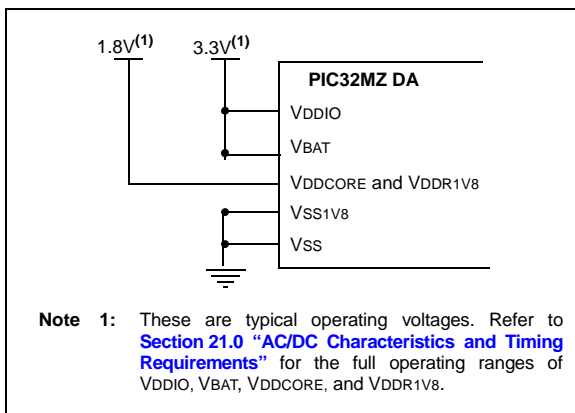

4.7 PIC32MK Power Requirements

Devices in the PIC32MK family are triple voltage supply designs. Two of the voltage supplies are identical to the PIC32MZ EC and PIC32MZ EF voltage supplies. The third voltage supply is for the VBAT pin, but it can be connected to the VDD power supply. See [Figure 4-6](#).

FIGURE 4-6: PIC32MK POWER CONNECTIONS

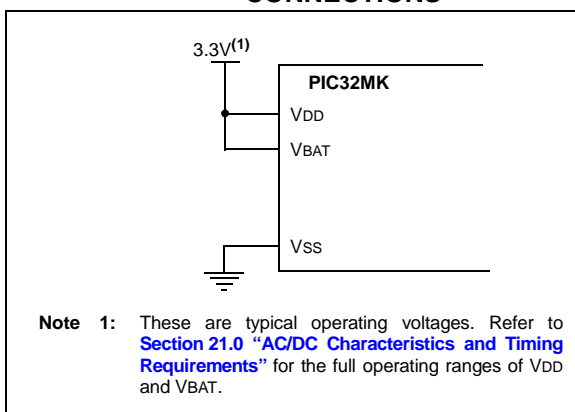

5.0 EJTAG vs. ICSP

Programming is accomplished through the EJTAG module in the CPU core. EJTAG is connected to either the full set of JTAG pins, or a reduced 2-wire to 4-wire EJTAG interface for ICSP mode. In both modes, programming of the PIC32 Flash memory is accomplished through the ETAP controller. The TAP Controller uses the TMS pin to determine if Instruction or Data registers should be accessed in the shift path between TDI and TDO, see [Figure 5-1](#).

The basic concept of EJTAG that is used for programming is the use of a special memory area called DMSEG (0xFF200000 to 0xFF2FFFFF), which is only available when the processor is running in Debug mode. All instructions are serially shifted into an internal buffer, and then loaded into the Instruction register and executed by the CPU. Instructions are fed through the ETAP state machine in 32-bit groups.

FIGURE 5-1: TAP CONTROLLER

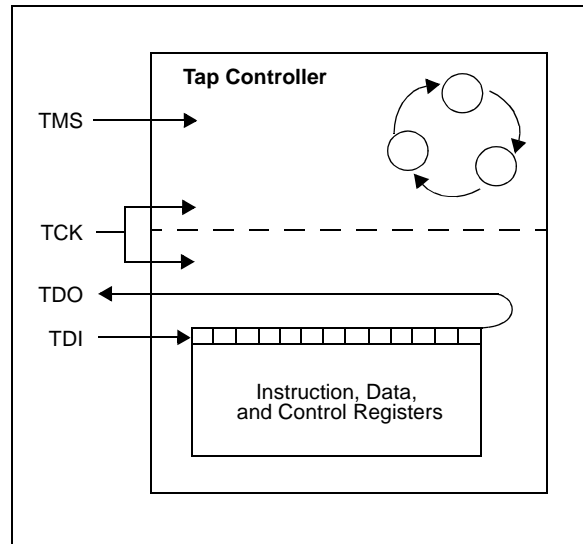

5.1 Programming Interface

Figure 5-2 shows the basic programming interface in PIC32 devices. Descriptions of each interface block are provided in subsequent sections.

FIGURE 5-2: BASIC PIC32 PROGRAMMING INTERFACE BLOCK DIAGRAM

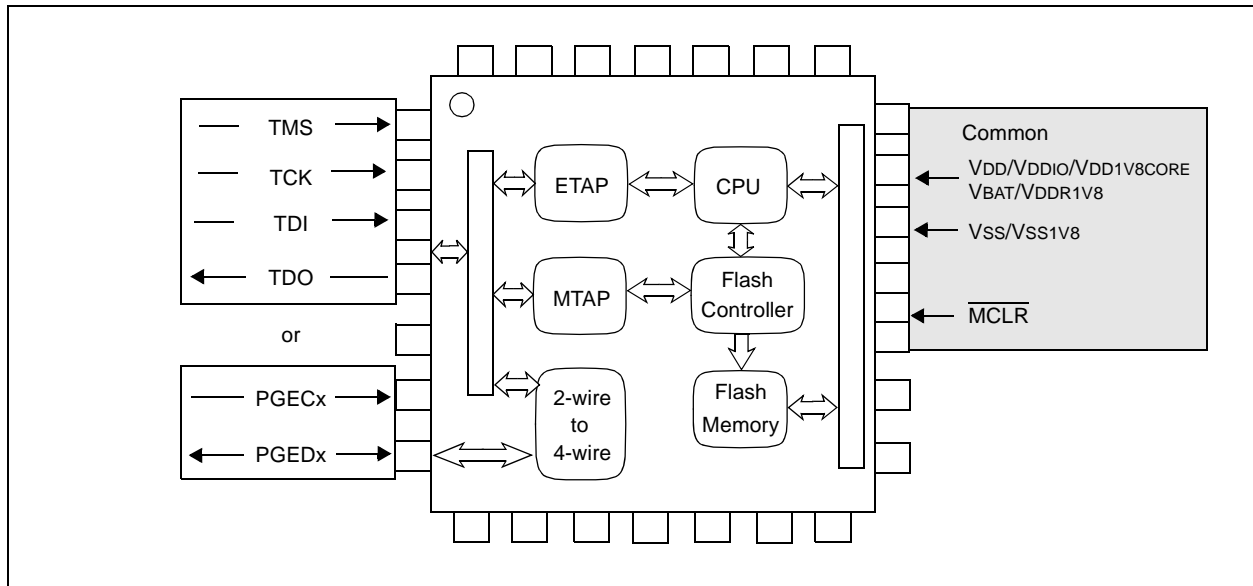

5.1.1 ETAP

This block serially feeds instructions and data into the CPU.

5.1.2 MTAP

In addition to the EJTAG TAP (ETAP) controller, the PIC32 device uses a second proprietary TAP controller for additional operations. The Microchip TAP (MTAP) controller supports two instructions relevant to programming: `MTAP_COMMAND` and TAP switch Instructions. See [Table 20-1](#) for a complete list of Instructions. The `MTAP_COMMAND` instruction provides a mechanism for a JTAG probe to send commands to the device through its Data register.

The programmer sends commands by shifting in the `MTAP_COMMAND` instruction through the `SendCommand` pseudo operation, and then sending the `MTAP_COMMAND DR` commands through the `XferData` pseudo operation, see [Table 20-2](#) for specific commands.

The probe does not need to issue a `MTAP_COMMAND` instruction for every command shifted into the Data register.

5.1.3 2-WIRE TO 4-WIRE

This block converts the 2-wire ICSP interface to the 4-wire JTAG interface.

5.1.4 CPU

The CPU executes instructions at 8 MHz through the internal oscillator.

5.1.5 FLASH CONTROLLER

The Flash controller controls erasing and programming of the Flash memory on the device.

5.1.6 FLASH MEMORY

The PIC32 device Flash memory is divided into two logical Flash partitions consisting of the Boot Flash Memory (BFM) and Program Flash Memory (PFM). The BFM begins at address `0x1FC00000`, and the PFM begins at address `0x1D000000`. Each Flash partition is divided into pages, which represent the smallest block of memory that can be erased. Depending on the device, page sizes are 256 words (1024 bytes), 1024 words (4096 bytes), or 4096 words (16,384 bytes). Row size indicates the number of words that are programmed with the row program command. There are always 8 rows within a page; therefore, devices with 256, 1024, and 4096 word page sizes have 32, 128, and 512 word row sizes, respectively. [Table 5-1](#) shows the PFM, BFM, row, and page size of each device family.

Memory locations of the BFM are reserved for the device Configuration registers, see [Section 19.0 "Configuration Memory and Device ID"](#) for more information.

PIC32

TABLE 5-1: CODE MEMORY SIZE

PIC32 Device	Row Size (Words)	Page Size (Words)	Boot Flash Memory Address (Bytes) (See Note 1)	Programming Executive (See Notes 2 and 3)
PIC32MX 110/120/130/150/170 210/220/230/350/270 (28/36/44-pin devices Only)	32	256	0x1FC00000-0x1FC00BFF (3 KB)	RIPE_11_aabbcc.hex
PIC32MX 120/130/150/170/230/250/ 270/530/550/570 (64/100-pin devices Only)				
PIC32MX 15X/17X/25X/27X (28/44-pin devices Only)				
PIC32MX 330/350/370/430/450/470	128	1024	0x1FC00000-0x1FC02FFF (12 KB)	RIPE_06_aabbcc.hex
PIC32MX 320/340/360/420/440/460				
PIC32MX 534/564/664/764				
PIC32MX 575/675/695/795				
PIC32MK 0512/1024XXD/E/F/K/L/M	128	1024	0x1FC00000-0x1FC04FFF (20 KB) 0x1FC20000-0x1FC24FFF (20 KB)	RIPE_15a_aabbcc.hex
PIC32MK 0256/0512XXG/H	128	1024	0x1FC00000-0x1FC04FFF (20 KB)	RIPE_15a_aabbcc.hex
PIC32MZ 05XX/10XX/20XX	512	4096	0x1FC00000-0x1FC13FFF (80 KB) 0x1FC20000-0x1FC33FFF (80 KB)	RIPE_15_aabbcc.hex

Note 1: Program Flash Memory address ranges are based on Program Flash size are as given below:

- 0x1D000000-0x1D003FFF (16 KB)
- 0x1D000000-0x1D007FFF (32 KB)
- 0x1D000000-0x1D00FFFF (64 KB)
- 0x1D000000-0x1D01FFFF (128 KB)
- 0x1D000000-0x1D03FFFF (256 KB)
- 0x1D000000-0x1D07FFFF (512 KB)
- 0x1D000000-0x1D0FFFFF (1024 KB)
- 0x1D000000-0x1D1FFFFF (2048 KB)

All Program Flash memory sizes are not supported by each family.

2: The Programming Executive can be obtained from the related product page on the Microchip web site, or it can be located in the following MPLAB® X IDE installation folders:

```

... \Microchip\MPLABX\<version>\mplab_ide\mplablibs\modules\ext\REALICE.jar
... \Microchip\MPLABX\<version>\mplab_ide\mplablibs\modules\ext\ICD3.jar
... \Microchip\MPLABX\<version>\mplab_ide\mplablibs\modules\ext\PICKIT3.jar

```

3: The last characters of the file name, aabbcc, vary based on the revision of the file.

5.2 4-wire JTAG Details

The 4-wire interface uses standard JTAG (IEEE 1149.1-2001) interface signals.

- TCK: Test Clock – drives data in/out
- TMS: Test Mode Select – selects operational mode
- TDI: Test Data Input – data into the device
- TDO: Test Data Output – data out of the device

Since only one data line is available, the protocol is necessarily serial (like SPI). The clock input is at the TCK pin. Configuration is performed by manipulating a state machine bit by bit through the TMS pin. One bit of data is transferred in and out per TCK clock pulse at the TDI and TDO pins. Different instruction modes can be loaded to read the chip ID or manipulate chip functions.

Data presented to TDI must be valid for a chip-specific setup time before, and hold time, after the rising edge of TCK. TDO data is valid for a chip-specific time after the falling edge of TCK, refer to [Figure 5-3](#).

FIGURE 5-3: 4-WIRE JTAG INTERFACE

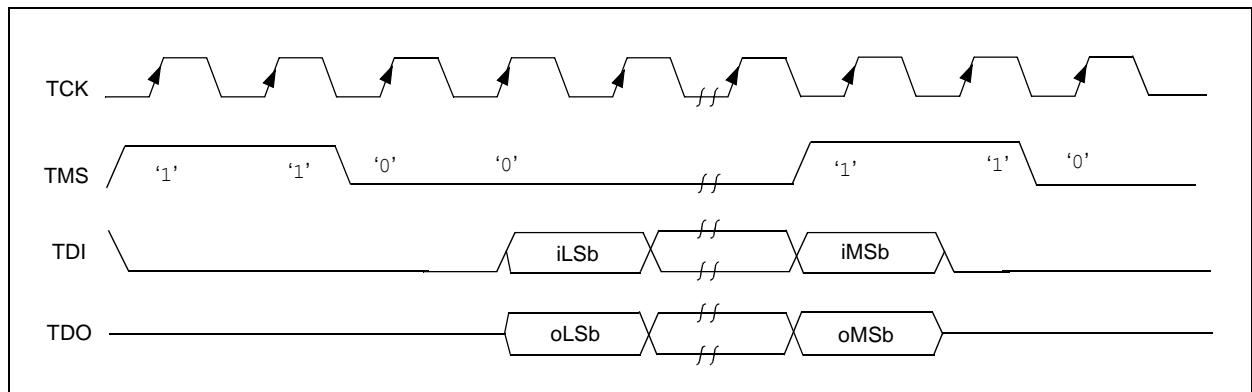

PIC32

5.3 2-wire ICSP Details

In ICSP mode, the 2-wire ICSP signals are time multiplexed into the 2-wire to 4-wire block. The 2-wire to 4-wire block then converts the signals to look like a 4-wire JTAG port to the TAP controller. The following are two possible modes of operation:

- 4-phase ICSP
- 2-phase ICSP

5.3.1 4-PHASE ICSP

In 4-phase ICSP mode, the TDI, TDO and TMS device pins are multiplexed onto PGEDx in four clocks, see [Figure 5-4](#). The Least Significant bit (LSb) is shifted first; and TDI and TMS are sampled on the falling edge of PGECx, while TDO is driven on the falling edge of PGECx. The 4-phase ICSP mode is used for both read and write data transfers.

5.3.2 2-PHASE ICSP

In 2-phase ICSP mode, the TMS and TDI device pins are multiplexed into PGEDx in two clocks, see [Figure 5-5](#). The LSb is shifted first; and TDI and TMS are sampled on the falling edge of PGECx. There is no TDO output provided in this mode. The 2-phase ICSP mode was designed to accelerate 2-wire, write-only transactions.

Note: The packet is not actually executed until the first clock of the next packet. To enter 2-wire, 2-phase ICSP mode, the TDOEN bit (DDPCON<0> or CFGCON<0>) must be set to '0'.

FIGURE 5-4: 2-WIRE, 4-PHASE

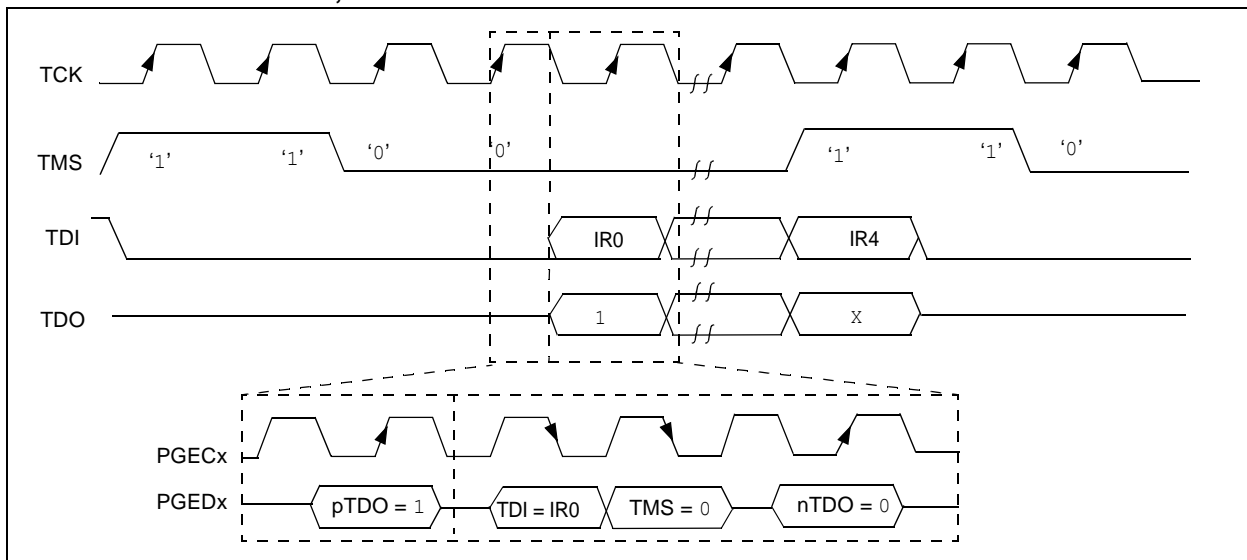
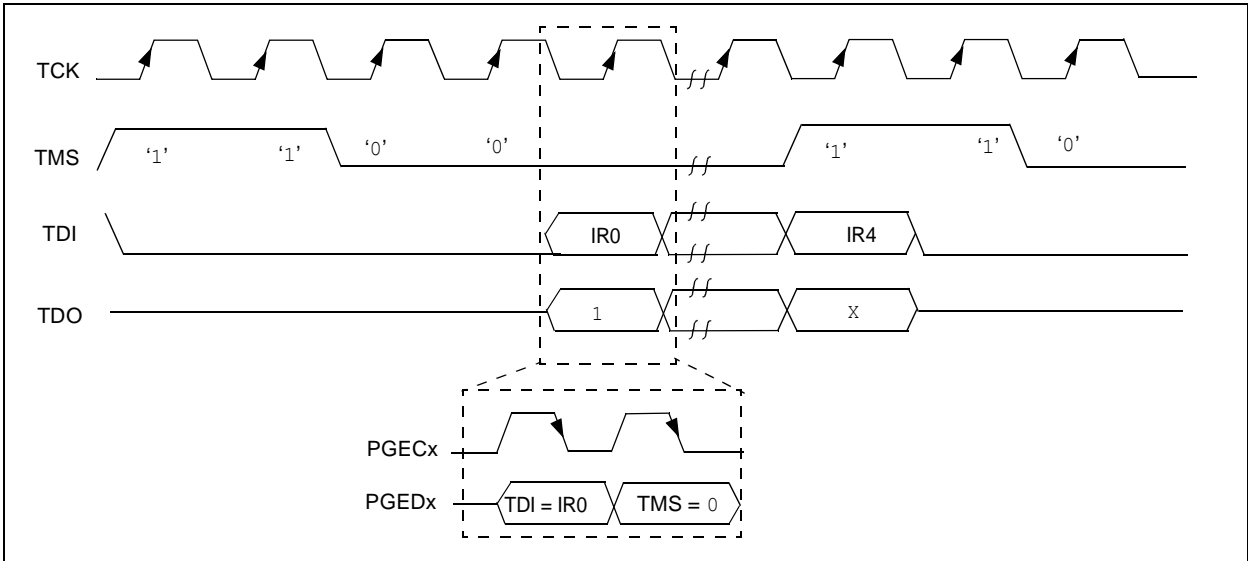

FIGURE 5-5: 2-WIRE, 2-PHASE



5.3.3 SYNCHRONIZATION

Some PIC32 devices can Reset the internal EJTAG state machine if the attached programmer loses synchronization with it. This can occur when noise is present on the PGCx signal.

To achieve resynchronization, the PGEDx pin is held high for 24 PGECx clock cycles. This forces five TMS events into the EJTAG controller and will place the EJTAG state machine into a Test Idle Reset. See [Figure 5-6](#) for an example of how to achieve resynchronization.

When asserting the PGEDx pin high, there may be contention on the pin as the device may attempt to drive TDO out onto the pin while the in-circuit emulator is driving in. This will only occur for a maximum of one cycle as TMS high will advance the EJTAG state machine out of a Shift-IR or Shift-DR state.

Synchronization in 2-wire, 2-phase mode is not supported.

FIGURE 5-6: ACHIEVING RESYNCHRONIZATION

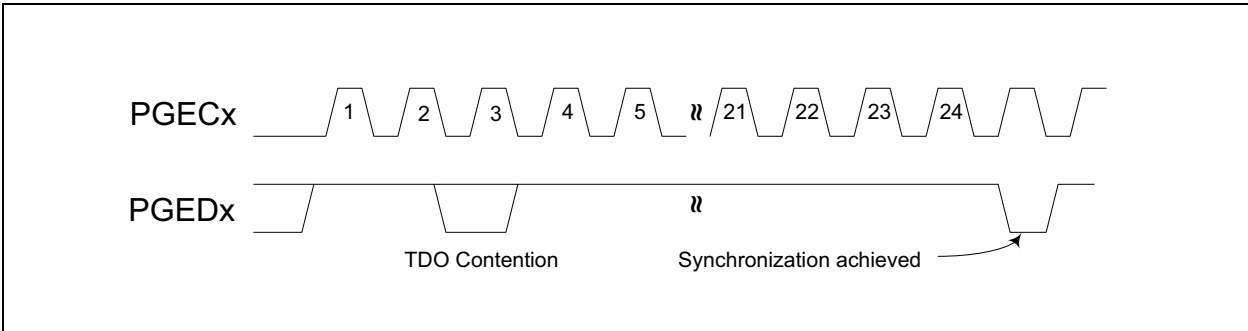

PIC32

6.0 PSEUDO OPERATIONS

To simplify the description of programming details, all operations will be described using pseudo operations. There are several functions used in the pseudo-code descriptions. These are used either to make the pseudo-code more readable, to abstract implementation-specific behavior, or both. When passing parameters with pseudo operation, the following syntax will be used:

- 5'h0x03 – send 5-bit hexadecimal value of 3
- 6'b011111 – send 6-bit binary value of 31

These functions are defined in this section, and include the following operations:

- **SetMode** (mode)
- **sendCommand** (command)
- oData = **XferData** (iData)
- oData = **XferFastData** (iData)
- oData = **XferInstruction** (instruction)

6.1 SetMode Pseudo Operation

Format:

SetMode (mode)

Purpose:

To set the EJTAG state machine to a specific state.

Description:

The value of mode is clocked into the device on signal TMS. TDI is set to a '0' and TDO is ignored.

Restrictions:

None.

Example:

SetMode (6'b011111)

FIGURE 6-1: SetMode 4-WIRE

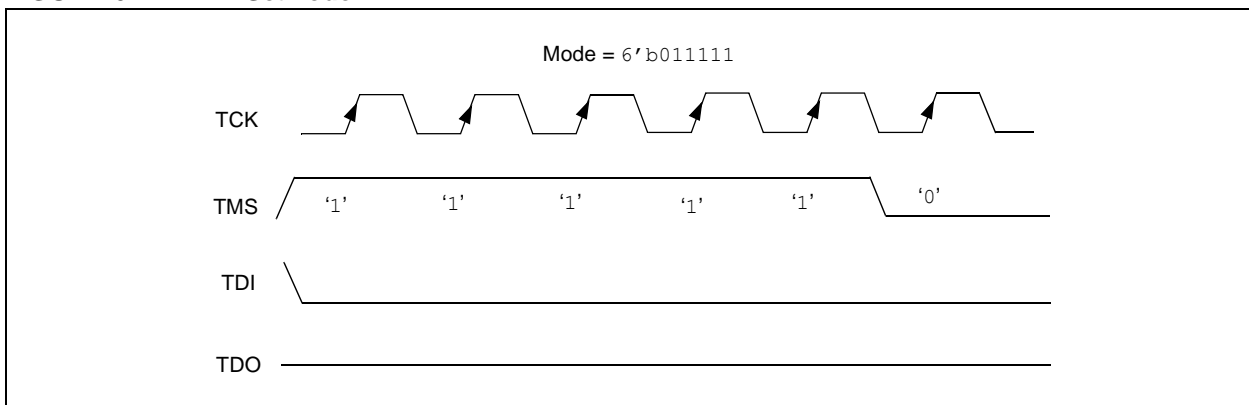
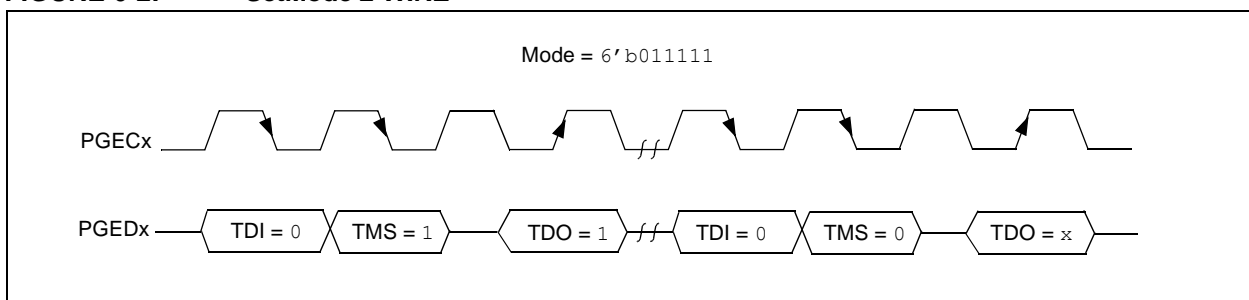

FIGURE 6-2: SetMode 2-WIRE



6.2 SendCommand Pseudo Operation

Format:

SendCommand (command)

Purpose:

To send a command to select a specific TAP register.

Description (in sequence):

1. The TMS Header is clocked into the device to select the Shift IR state
2. The command is clocked into the device on TDI while holding signal TMS low.
3. The last Most Significant bit (MSb) of the command is clocked in while setting TMS high.
4. The TMS Footer is clocked in on TMS to return the TAP controller to the Run/Test Idle state.

Restrictions:

None.

Example:

SendCommand (5'h0x07)

FIGURE 6-3: SendCommand 4-WIRE

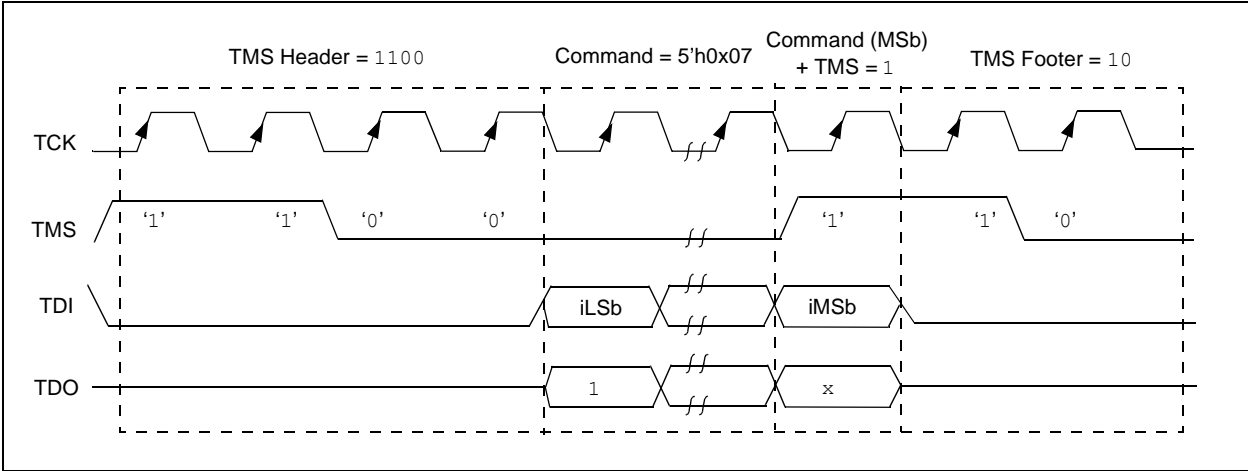
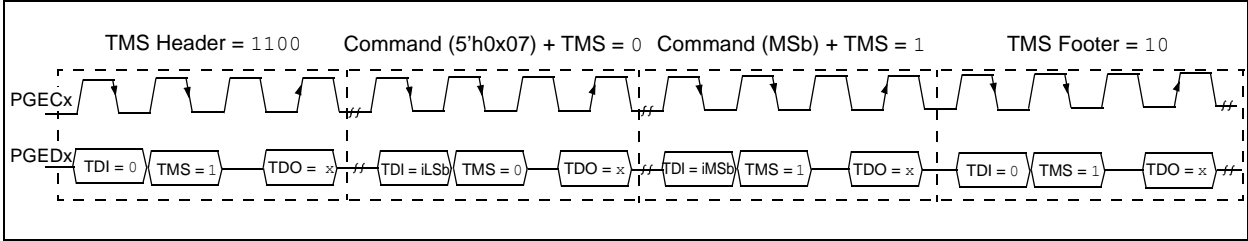

FIGURE 6-4: SendCommand 2-WIRE (4-PHASE)



PIC32

6.3 XferData Pseudo Operation

Format:

oData = XferData (iData)

Purpose:

To clock data to and from the register selected by the command.

Description (in sequence):

1. The TMS Header is clocked into the device to select the Shift DR state.
2. The data is clocked in/out of the device on TDI/TDO while holding signal TMS low.
3. The last MSb of the data is clocked in/out while setting TMS high.
4. The TMS Footer is clocked in on TMS to return the TAP controller to the Run/Test Idle state.

Restrictions:

None.

Example:

oData = XferData (32'h0x12)

FIGURE 6-5: XferData 4-WIRE

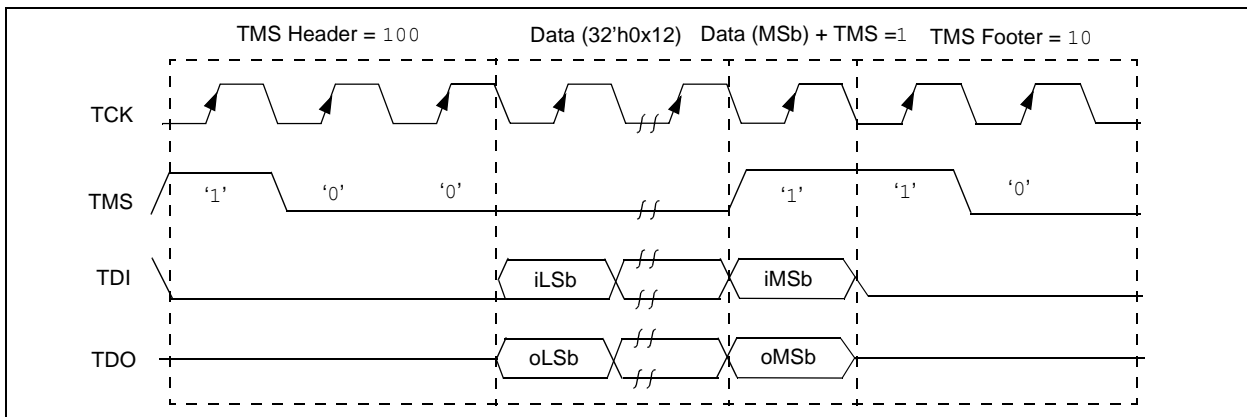
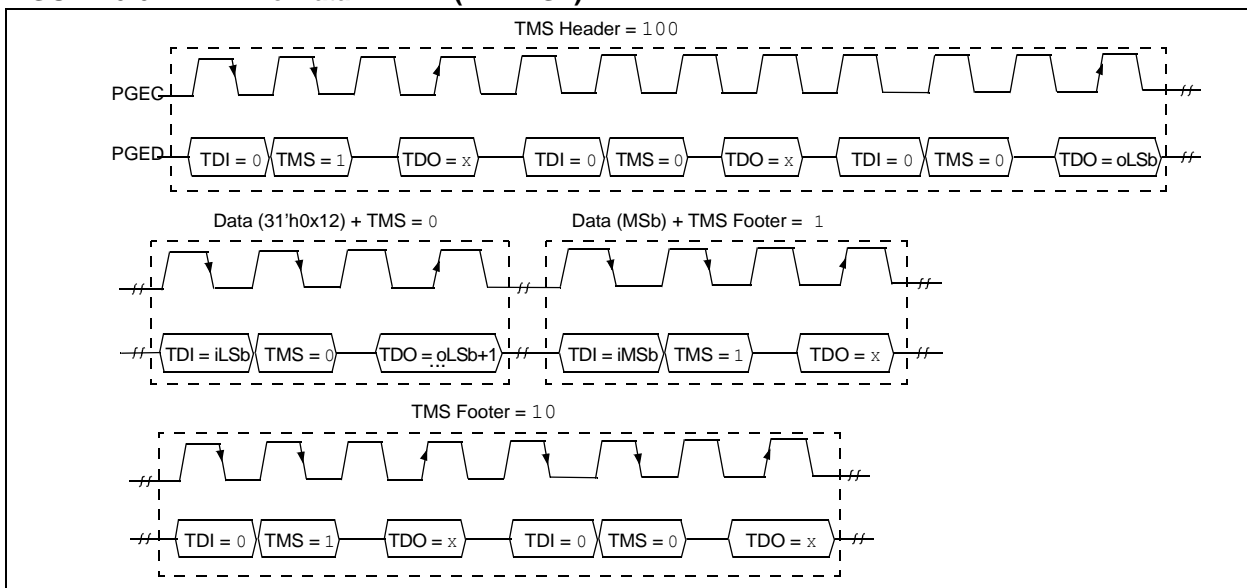

FIGURE 6-6: XferData 2-WIRE (4-PHASE)



6.4 XferFastData Pseudo Operation

Format:

`oData = XferFastData (iData)`

Purpose:

To quickly send 32 bits of data in/out of the device.

Description (in sequence):

1. The TMS Header is clocked into the device to select the Shift DR state.

Note: For 2-wire (4-phase) – on the last clock, the `oPrAcc` bit is shifted out on TDO while clocking in the TMS Header. If the value of `oPrAcc` is not '1', the whole operation must be repeated.

2. The input value of the `PrAcc` bit, which is '0', is clocked in.

Note: For 2-wire (4-phase) – the TDO during this operation will be the LSb of output data. The rest of the 31 bits of the input data are clocked in and the 31 bits of output data are clocked out. For the last bit of the input data, the TMS Footer = 1 is set.

3. TMS Footer = 10 is clocked in to return the TAP controller to the Run/Test Idle state.

Restrictions:

The `SendCommand (ETAP_FASTDATA)` must be sent first to select the Fastdata register, as shown in [Example 6-1](#). See [Table 20-4](#) for a detailed descriptions of commands.

Note: The 2-phase XferData is only used when talking to the PE. See [Section 17.0 “The Programming Executive”](#) for more information.

EXAMPLE 6-1: SendCommand

```
// Select the Fastdata Register
SendCommand(ETAP_FASTDATA)
// Send/Receive 32-bit Data
oData = XferFastData(32'h0x12)
```

FIGURE 6-7: XferFastData 4-WIRE

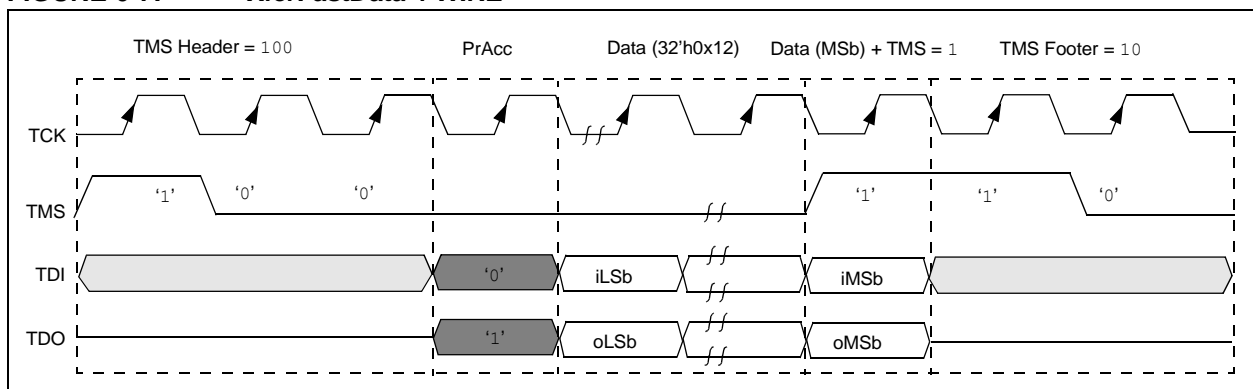
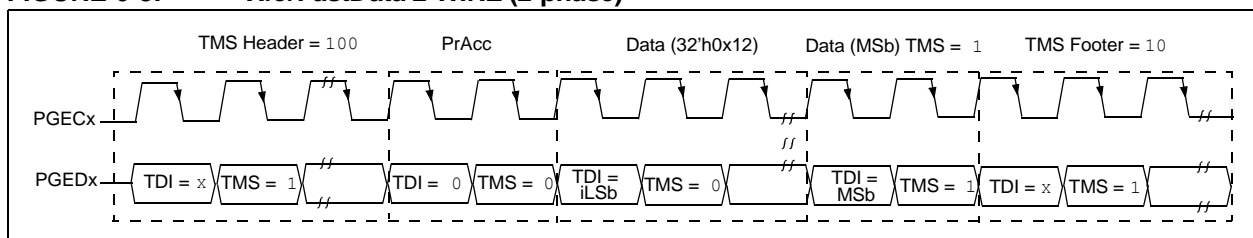
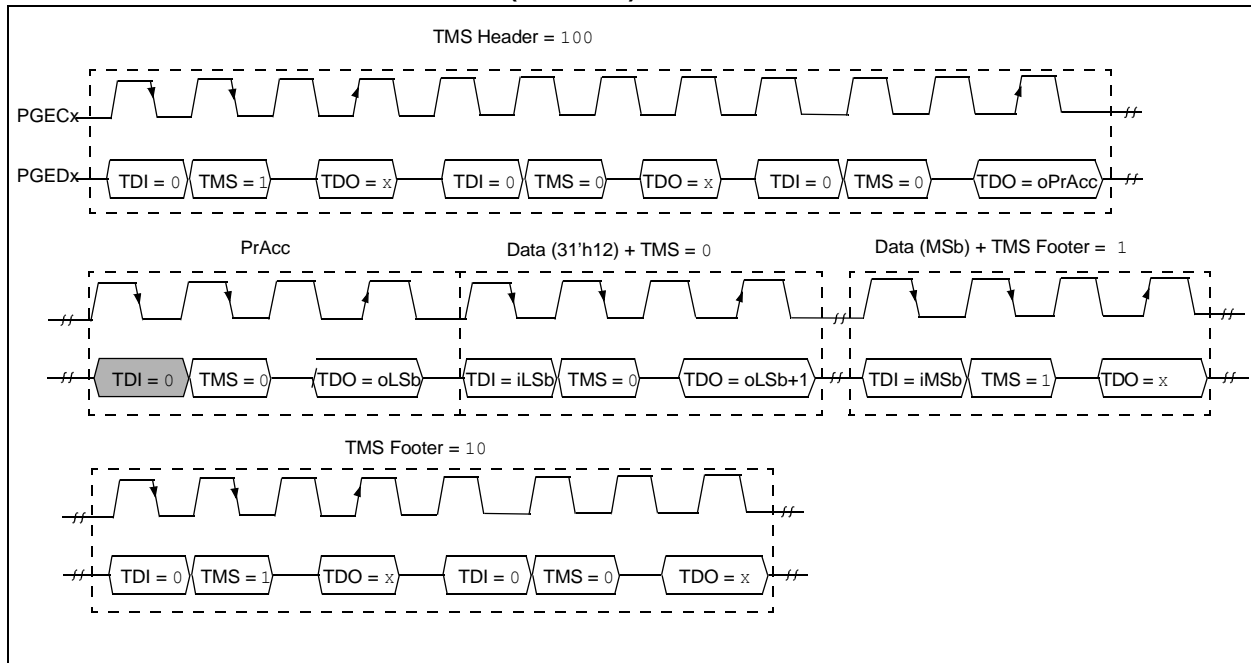

FIGURE 6-8: XferFastData 2-WIRE (2-phase)



PIC32

FIGURE 6-9: XferFastData 2-WIRE (4-PHASE)



6.5 XferInstruction Pseudo Operation

Format:

XferInstruction (instruction)

Purpose:

To send 32 bits of data for the device to execute.

Description:

The instruction is clocked into the device and then executed by CPU.

Restrictions:

The device must be in Debug mode.

EXAMPLE 6-2: XferInstruction

```
XferInstruction (instruction)
{
    // Select Control Register
    SendCommand(ETAP_CONTROL);
    // Wait until CPU is ready
    // Check if Processor Access bit (bit 18) is set
    do {
        controlVal = XferData(32'h0x0004C000);
    } while( PrAcc(contorlVal<18>) is not '1' );

    // Select Data Register
    SendCommand(ETAP_DATA);

    // Send the instruction
    XferData(instruction);

    // Tell CPU to execute instruction
    SendCommand(ETAP_CONTROL);
    XferData(32'h0x0000C000);
}
```

PIC32

6.6 ReadFromAddress Pseudo Operation

Format:

oData = ReadFromAddress (address)

Purpose:

To send 32 bits of data to the device memory.

Description:

The 32-bit data is read from the memory at the address specified in the “address” parameter.

Restrictions:

The device must be in Debug mode.

EXAMPLE 6-3: ReadFromAddress FOR PIC32MX, PIC32MZ, AND PIC32MK DEVICES

```
ReadFromAddress (address)
{

// Load Fast Data register address to s3
instruction = 0x3c130000;
instruction |= (0xff200000>>16)&0x0000ffff;
XferInstruction(instruction); // lui s3, <FAST_DATA_REG_ADDRESS(31:16)> - set address of fast
data register

// Load memory address to be read into t0
instruction = 0x3c080000;
instruction |= (address>>16)&0x0000ffff;
XferInstruction(instruction); // lui t0, <DATA_ADDRESS(31:16)> - set address of data
instruction = 0x35080000;
instruction |= (address&0x0000ffff);
XferInstruction(instruction); // ori t0, <DATA_ADDRESS(15:0)> - set address of data

// Read data
XferInstruction(0x8d090000); // lw t1, 0(t0)

// Store data into Fast Data register
XferInstruction(0xae690000); // sw t1, 0(s3) - store data to fast data register
XferInstruction(0); // nop

// Shift out the data
SendCommand(ETAP_FASTDATA);
oData = XferFastData(32'h0x00000000);

return oData;
}
```

6.7 Synchronize Pseudo Operation

Format:

Synchronize ()

Purpose:

To reset the EJTAG state machine into Test Idle Reset.

Description:

The PGEDx signal is held high for 24 PGECx clock cycles. All other signals are ignored.

Restrictions:

None.

FIGURE 6-10: ACHIEVING RESYNCHRONIZATION

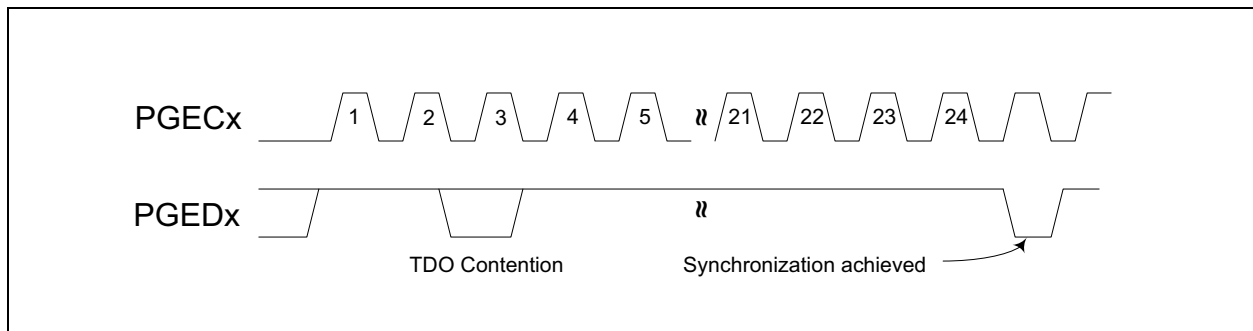

PIC32

7.0 ENTERING 2-WIRE ENHANCED ICSP MODE

To use the 2-wire PGEDx and PGECx pins for programming, they must be enabled. Note that any pair of programming pins available on a particular device may be used, however, they must be used as a pair. PGED1 must be used with PGEC1, and so on.

Note: If using the 4-wire JTAG interface, the following procedure is not necessary.

The following steps are required to enter 2-wire Enhanced ICSP mode:

1. The $\overline{\text{MCLR}}$ pin is briefly driven high, then low.
2. A 32-bit key sequence is clocked into PGEDx.
3. The $\overline{\text{MCLR}}$ pin is then driven high within a specified period of time and held.

Refer to [Section 21.0 “AC/DC Characteristics and Timing Requirements”](#) for timing requirements.

The programming voltage applied to the $\overline{\text{MCLR}}$ pin is V_{IH} , which is essentially V_{DD} , in PIC32 devices. There is no minimum time requirement for holding at V_{IH} . After V_{IH} is removed, an interval of at least P18 must elapse before presenting the key sequence on PGEDx.

The key sequence is a specific 32-bit pattern: ‘0100 1101 0100 0011 0100 1000 0101 0000’ (the acronym ‘MCHP’, in ASCII). The device will enter Program/Verify mode only if the key sequence is valid. The MSb of the Most Significant nibble must be shifted in first.

Once the key sequence is complete, V_{IH} must be applied to the $\overline{\text{MCLR}}$ pin and held at that level for as long as the 2-wire Enhanced ICSP interface is to be maintained. An interval of at least time P19 and P7 must elapse before presenting data on PGEDx. Signals appearing on PGEDx before P7 has elapsed will not be interpreted as valid.

Upon successful entry, the programming operations documented in subsequent sections can be performed. While in 2-wire Enhanced ICSP mode, all unused I/Os are placed in the high-impedance state.

Note: Entry into ICSP mode places the device in Reset to prevent instructions from executing. To release the Reset, the `MCHP_DE_ASSERT_RST` command must be issued.

FIGURE 7-1: ENTERING ENHANCED ICSP™ MODE

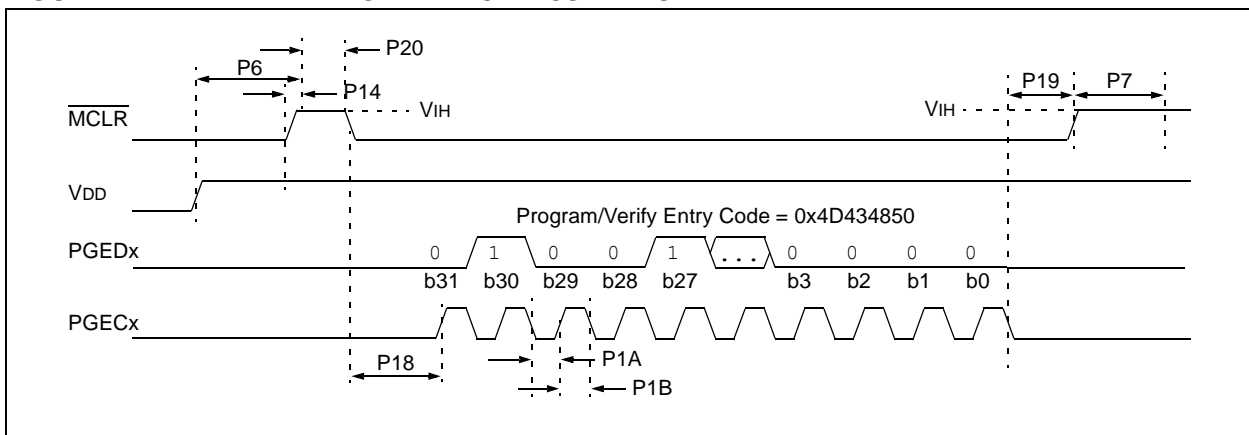

8.0 CHECK DEVICE STATUS

Before a device can be programmed, the programmer must check the status of the device to ensure that it is ready to receive information.

FIGURE 8-1: CHECK DEVICE STATUS

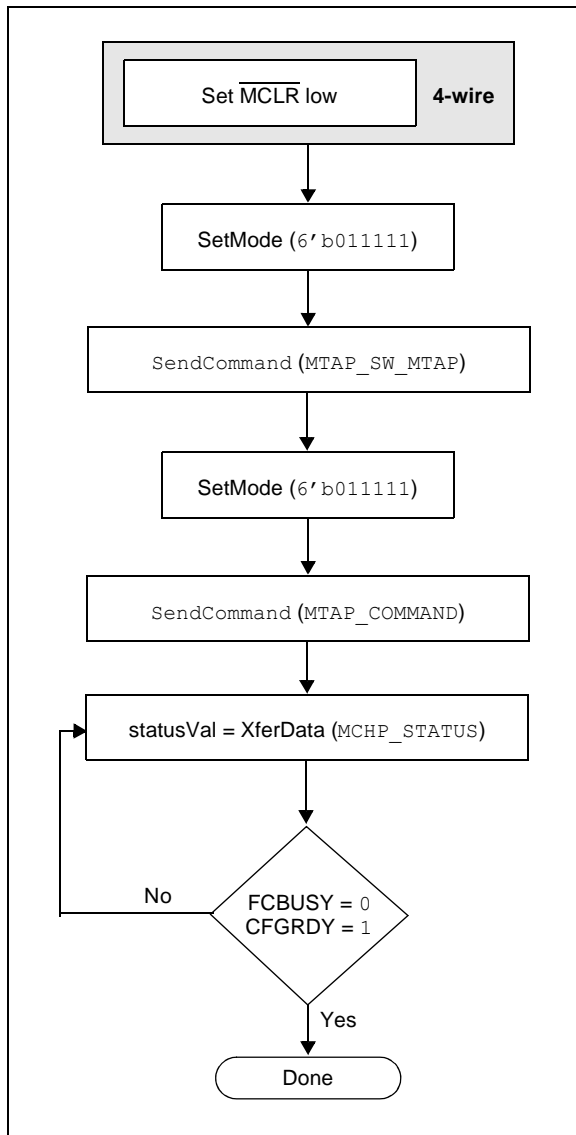

8.1 4-wire Interface

The setup sequence to enter 4-wire JTAG programming should be done while asserting the $\overline{\text{MCLR}}$ pin. Once the programming mode is entered, the $\overline{\text{MCLR}}$ pin can be released to allow the processor to execute instructions or drive ports.

The following steps are required to check the device status using the 4-wire interface:

1. Set the $\overline{\text{MCLR}}$ pin low.
2. SetMode (6'b011111) to force the Chip TAP controller into Run Test/Idle state.
3. SendCommand (MTAP_SW_MTAP).
4. SetMode (6'b011111) to force the Chip TAP controller into Run Test/Idle state.
5. SendCommand (MTAP_COMMAND).
6. statusVal = XferData (MCHP_STATUS).
7. If CFGRDY (statusVal<3>) is not '1' and FCBUSY (statusVal<2>) is not '0' GOTO step 5.

Note: If using the 4-wire interface, the oscillator source, as selected by the Configuration Words, must be present to access the Flash memory. In an unprogrammed device, the oscillator source is the internal FRC allowing for Flash memory access. If the Configuration Words have been reprogrammed selecting an external oscillator source then it must be present for Flash memory access. See the “Special Features” chapter in the specific device data sheet for details regarding oscillator selection using the Configuration Word settings.

8.2 2-wire Interface

The following steps are required to check the device status using the 2-wire interface:

1. SetMode (6'b011111) to force the Chip TAP controller into Run Test/Idle state.
2. SendCommand (MTAP_SW_MTAP).
3. SetMode (6'b011111) to force the Chip TAP controller into Run Test/Idle state.
4. SendCommand (MTAP_COMMAND).
5. statusVal = XferData (MCHP_STATUS).
6. If CFGRDY (statusVal<3>) is not '1' and FCBUSY (statusVal<2>) is not '0', GOTO step 4.

Note: If the CFGRDY and FCBUSY bits do not come to the proper state within 10 ms, the sequence may have been executed incorrectly or the device is damaged.

PIC32

9.0 ERASING THE DEVICE

Before a device can be programmed, it must be erased. The erase operation writes all '1s' to the Flash memory and prepares it to program a new set of data. Once a device is erased, it can be verified by performing a "Blank Check" operation. See [Section 9.1 "Blank Check"](#) for more information.

The procedure for erasing program memory (Program, boot, and Configuration memory) consists of selecting the MTAP and sending the `MCHP_ERASE` command. The programmer must wait for the erase operation to complete by reading and verifying bits in the `MCHP_STATUS` value. [Figure 9-1](#) illustrates the process for performing a Chip Erase.

Note: The Device ID memory locations are read-only and cannot be erased. Therefore, Chip Erase has no effect on these memory locations.

The following steps are required to erase a target device:

1. `SendCommand (MTAP_SW_MTAP)`.
2. `SetMode (6'b0111111)`.
3. `SendCommand (MTAP_COMMAND)`.
4. `XferData (MCHP_ERASE)`.
5. `XferData (MCHP_DE_ASSERT_RST)`. *This step is not required for PIC32MX devices.*
6. Delay 10 ms.
7. `statusVal = XferData (MCHP_STATUS)`.
8. If `CFGRDY (statusVal<3>)` is not '1' and `FCBUSY (statusVal<2>)` is not '0', GOTO to step 5.

Note: The Chip Erase operation is a self-timed operation. If the `FCBUSY` and `CFGRDY` bits do not set properly within the specified Chip Erase time, the sequence may have been executed incorrectly or the device is damaged.

FIGURE 9-1: ERASE DEVICE

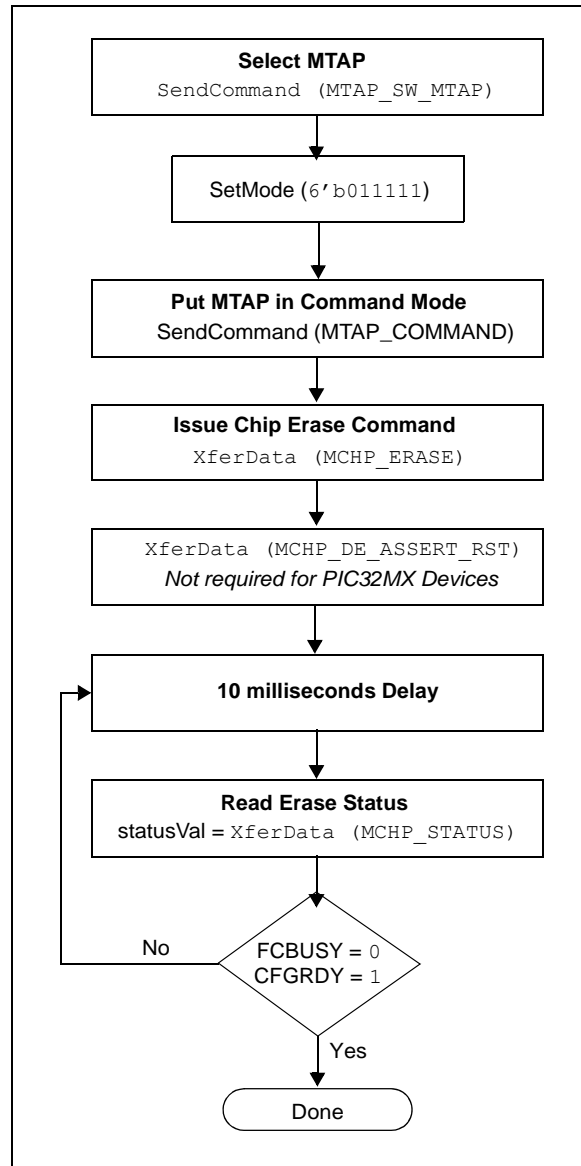

9.1 Blank Check

The term "Blank Check" implies verifying that the device has been successfully erased and has no programmed memory locations. A blank or erased memory location always reads as '1'.

The device Configuration registers are ignored by the Blank Check. Additionally, all unimplemented memory space should be ignored from the Blank Check.

10.0 ENTERING SERIAL EXECUTION MODE

Before programming a device, it must be placed in Serial Execution mode. The procedure for entering Serial Execution mode consists of verifying that the device is not code-protected. If the device is code-protected, a Chip Erase must be performed. See [Section 9.0 “Erasing the Device”](#) for details.

FIGURE 10-1: ENTERING SERIAL EXECUTION MODE

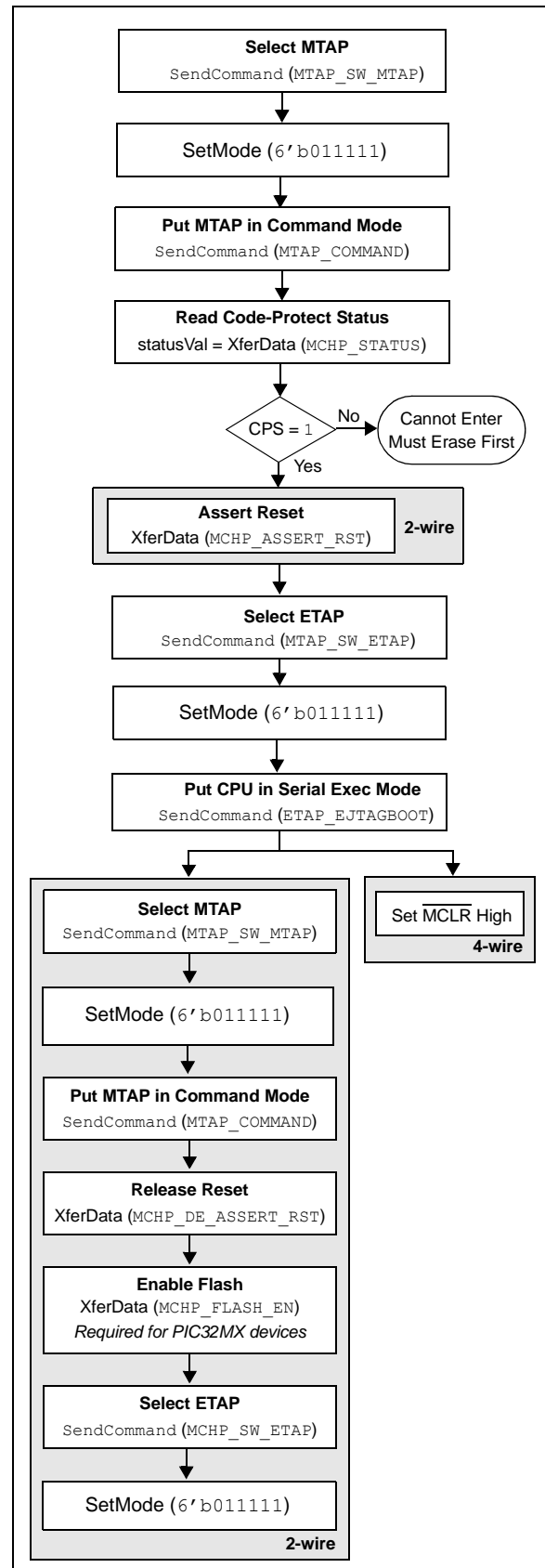

PIC32

10.1 4-wire Interface

The following steps are required to enter Serial Execution mode:

Note: It is assumed that the $\overline{\text{MCLR}}$ pin has been driven low from the previous Check Device Status step (see [Figure 8-1](#)).

1. `SendCommand (MTAP_SW_MTAP).`
2. `SetMode (6'b0111111).`
3. `SendCommand (MTAP_COMMAND).`
4. `statusVal = XferData (MCHP_STATUS).`
5. If CPS (`statusVal<7>`) is not '1', the device must be erased first.
6. `SendCommand (MTAP_SW_ETAP).`
7. `SetMode (6'b0111111).`
8. `SendCommand (ETAP_EJTAGBOOT).`
9. Set the $\overline{\text{MCLR}}$ pin high.

10.2 2-wire Interface

The following steps are required to enter Serial Execution mode:

1. `SendCommand (MTAP_SW_MTAP).`
2. `SetMode (6'b0111111).`
3. `SendCommand (MTAP_COMMAND).`
4. `statusVal = XferData (MCHP_STATUS).`
5. If CPS (`statusVal<7>`) is not '1', the device must be erased first.
6. `XferData (MCHP_ASSERT_RST).`
7. `SendCommand (MTAP_SW_ETAP).`
8. `SetMode (6'b0111111).`
9. `SendCommand (ETAP_EJTAGBOOT).`
10. `SendCommand (MTAP_SW_MTAP).`
11. `SetMode (6'b0111111).`
12. `SendCommand (MTAP_COMMAND).`
13. `XferData (MCHP_DE_ASSERT_RST).`
14. `XferData (MCHP_FLASH_ENABLE).` *This step is required for PIC32MX family devices.*
15. `SendCommand (MTAP_SW_ETAP).`
16. `SetMode (6'b0111111).`

11.0 DOWNLOADING THE PROGRAMMING EXECUTIVE (PE)

The PE resides in RAM memory and is executed by the CPU to program the device. The PE provides the mechanism for the programmer to program and verify PIC32 devices using a simple command set and communication protocol. There are several basic functions provided by the PE:

- Read memory
- Erase memory
- Program memory
- Blank check
- Read executive firmware revision
- Get the Cyclic Redundancy Check (CRC) of Flash memory locations

The PE performs the low-level tasks required for programming and verifying a device. This allows the programmer to program the device by issuing the appropriate commands and data. A detailed description for each command is provided in [Section 17.2 “The PE Command Set”](#).

The PE uses the device’s data RAM for variable storage and program execution. After the PE has run, no assumptions should be made about the contents of data RAM.

After the PE is loaded into the data RAM, the PIC32 family can be programmed using the command set shown in [Table 17-1](#).

FIGURE 11-1: DOWNLOADING THE PE

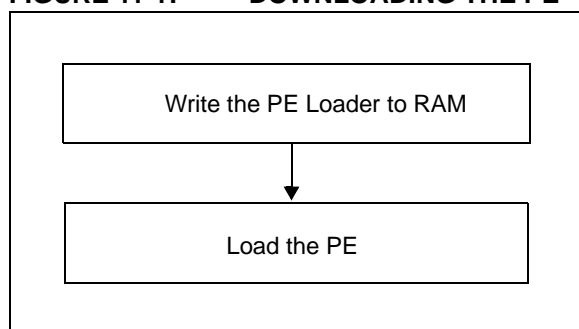

Loading the PE in the memory is a two step process:

1. Load the PE loader in the data RAM. (The PE loader loads the PE binary file in the proper location of the data RAM, and when done, jumps to the programming exec and starts executing it.)
2. Feed the PE binary to the PE loader.

[Table 11-1](#) lists the steps that are required to download the PE.

TABLE 11-1: DOWNLOAD THE PE OP CODES

Operation	Operand
Step 1: PIC32MX devices only: Initialize BMXCON to 0x1F0040. The instruction sequence executed by the PIC32 core is:	
lui a0,0xbf88	
ori a0,a0,0x2000 /* address of BMXCON */	
lui a1,0x1f	
ori a1,a1,0x40 /* a1 has 0x1f0040 */	
sw a1,0(a0) /* BMXCON initialized */	
XferInstruction	0x3c04bf88
XferInstruction	0x34842000
XferInstruction	0x3c05001f
XferInstruction	0x34a50040
XferInstruction	0xac850000
Step 2: PIC32MX devices only: Initialize BMXDKPBA to 0x800. The instruction sequence executed by the PIC32 core is:	
li a1,0x800	
sw a1,16(a0)	
XferInstruction	0x34050800
XferInstruction	0xac850010
Step 3: PIC32MX devices only: Initialize BMXDUDBA and BMXDUPBA to the value of BMXDMSZ. The instruction sequence executed by the PIC32 core is:	
lw a1,64(a0) /* load BMXDMSZ */	
sw a1,32(a0)	
sw a1,48(a0)	
XferInstruction	0x8C850040
XferInstruction	0xac850020
XferInstruction	0xac850030
Step 4: Set up PIC32 RAM address for PE. The instruction sequence executed by the PIC32 core is:	
lui a0,0xa000	
ori a0,a0,0x800	
XferInstruction	0x3c04a000
XferInstruction	0x34840800
Step 5: Load the PE_Loader. Repeat this step (Step 5) until the entire PE_Loader is loaded in the PIC32 memory. In the operands field, “<PE_loader hi++>” represents the MSBs 31 through 16 of the PE loader op codes shown in Table 11-2 . Likewise, “<PE_loader lo++>” represents the LSbs 15 through 0 of the PE loader op codes shown in Table 11-2 . The “++” sign indicates that when these operations are performed in succession, the new word is to be transferred from the list of op codes of the LPE Loader shown in Table 11-2 . The instruction sequence executed by the PIC32 core is:	
lui a2, <PE_loader hi++>	
ori a2,a2, <PE_loader lo++>	
sw a2,0(a0)	
addiu a0,a0,4	
XferInstruction	(0x3c06 <PE_loader hi++>)

PIC32

TABLE 11-1: DOWNLOAD THE PE OP CODES (CONTINUED)

Operation	Operand
XferInstruction	(0x34c6 <PE_loader lo++>)
XferInstruction	0xac860000
XferInstruction	0x24840004
Step 6: Jump to the PE Loader. The instruction sequence executed by the PIC32 core is: <pre> lui t9, 0xa000 ori t9, t9, 0x800 jr t9 nop </pre>	
XferInstruction	0x3c19a000
XferInstruction	0x37390800
XferInstruction	0x03200008
XferInstruction	0x00000000
Step 7: Load the PE using the PE Loader. Repeat the last instruction of this step (Step 7) until the entire PE is loaded into the PIC32 memory. In this step, you are given an Intel® Hex format file of the PE that you will parse and transfer a number of 32-bit words at a time to the PIC32 memory (refer to Appendix B: "Hex File Format"). The instruction sequence executed by the PIC32 is shown in Table 11-2 .	
SendCommand	ETAP_FASTDATA
XferFastData	PE_ADDRESS (Address of PE program block from PE Hex file)
XferFastData	PE_SIZE (Number of 32-bit words of the program block from PE Hex file)
XferFastData	PE software op code from PE Hex file (PE Instructions)
Step 8: Jump to the PE. Magic number (0xDEAD0000) instructs the PE Loader that the PE is completely loaded into the memory. When the PE Loader sees the magic number, it jumps to the PE.	
XferFastData	0x00000000
XferFastData	0xDEAD0000

TABLE 11-2: PE LOADER OP CODES

Op code	Instruction
0x24840004	addiu a0, a0, 4
0x1460fffb	bnez v1, <here2>
0x00000000	nop
0x1000fff3	b <here1>
0x00000000	nop
	here3:
0x3c02a000	lui v0, 0xa000
0x34420900	ori v0, v0, 0x900
0x00400008	jr v0
0x00000000	nop

TABLE 11-2: PE LOADER OP CODES

Op code	Instruction
0x3c07dead	lui a3, 0xdead
0x3c06ff20	lui a2, 0xff20
0x3c05ff20	lui a1, 0xff20
	here1:
0x8cc40000	lw a0, 0 (a2)
0x8cc30000	lw v1, 0 (a2)
0x1067000b	beq v1, a3, <here3>
0x00000000	nop
0x1060fffb	beqz v1, <here1>
0x00000000	nop
	here2:
0x8ca20000	lw v0, 0 (a1)
0x2463ffff	addiu v1, v1, -1
0xac820000	sw v0, 0 (a0)

12.0 DOWNLOADING A DATA BLOCK

To program a block of data to the PIC32 device, it must be loaded into SRAM.

12.1 Without the PE

To program a block of memory without using the PE, the block of data must first be written to RAM. This method requires the programmer to transfer the actual machine instructions with embedded (immediate) data for writing the block of data to the devices internal RAM memory.

12.2 With the PE

When using the PE, the steps in [Section 12.0 “Downloading a Data Block”](#) and [Section 14.0 “Initiating a Flash Row Write”](#) are handled in two single commands: `ROW_PROGRAM` and `PROGRAM`.

The `ROW_PROGRAM` command programs a single row of Flash data, while the `PROGRAM` command programs multiple rows of Flash data. Both of these commands are documented in [Section 17.0 “The Programming Executive”](#).

FIGURE 12-1: DOWNLOADING DATA WITHOUT THE PE

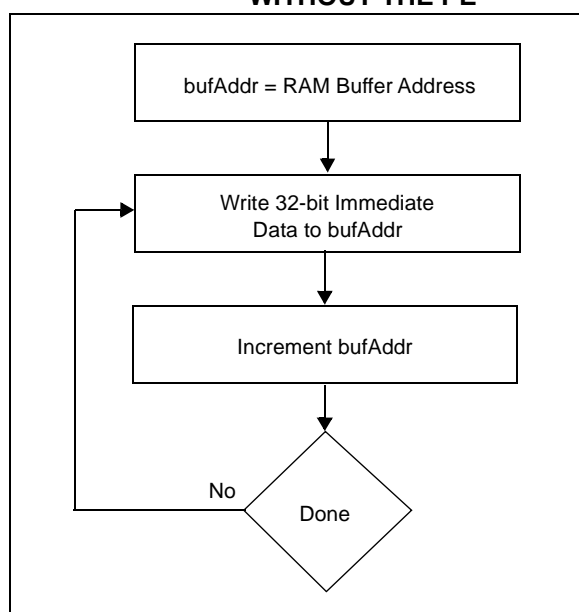

The following steps are required to download a block of data:

1. `XferInstruction` (op code).
2. Repeat Step 1 until the last instruction is transferred to CPU.

TABLE 12-1: DOWNLOAD DATA OP CODES

Op code	Instruction
Step 1: Initialize SRAM Base Address to 0xA0000000.	
3c10a000	<code>lui s0, 0xA000;</code>
Step 2: Write the entire row of data to be programmed into system SRAM.	
3c08<DATA>	<code>lui t0, <DATA(31:16)>;</code>
3508<DATA>	<code>ori t0, t0, <DATA(15:0)>;</code>
ae08<OFFSET>	<code>sw t0, <OFFSET>(s0);</code> <code>// OFFSET increments by 4</code>
Step 3: Repeat Step 2 until one row of data has been loaded.	

PIC32

13.0 INITIATING A PAGE ERASE

An individual page may be erased rather than erasing all of Flash memory. The PE is not used in this case.

PIC32MK family devices can perform an erase retry on a page by increasing the internal voltage used to perform the erase.

TABLE 13-1: PAGE ERASE OP CODES

Op Code	Instruction
Step 1: All PIC32 devices: Initialize constants. Registers a1, a2, and a3 are set for WREN = 1 or NVMOP<3:0> = 0100, WR = 1 and WREN = 1, respectively. Registers s1 and s2 are set for the unlock data values and s0 is initialized to '0'.	
34054004	ori a1, \$0, 0x4004
34068000	ori a2, \$0, 0x8000
34074000	ori a3, \$0, 0x4000
3c11aa99	lui s1, 0xaa99
36316655	ori s1, s1, 0x6655
3c125566	lui s2, 0x5566
365299aa	ori s2, s2, 0x99aa
3c100000	lui s0, 0x0000
Step 2: PIC32MX family devices only: Set register a0 to the base address of the NVM register (0xBF80_F400).	
3c04bf80	lui a0, 0xbf80
3484f400	ori a0, a0, 0xf400
Step 3: PIC32MK and PIC32MZ family devices only: Set register a0 to the base address of the NVM register (0xBF80_0600). Register s3 is set for the value used to disable write protection in NVMBPB.	
3c04b480	lui a0, 0xbf80
34840600	ori a0, a0, 0x0600
34138080	ori s3, \$0, 0x8080
Step 4: PIC32MK and PIC32MZ family devices only: Unlock and disable Boot Flash write protection.	
ac910010	sw s1, 16(a0)
ac920010	sw s2, 16(a0)
ac930090	sw s3, 144(a0)
00000000	nop
Step 5: PIC32MK family devices only: Save the contents of NVMCON2.	
8c9400a0	lw s4, 160(a0)
Step 6: PIC32MK family devices only: Set the initial programming voltage level and enable page testing (unlock required).	
36953000	ori s5, s4, 0x3000
32b5fcff	andi s5, s5, 0xFCFF
	here3:
ac910010	sw s1, 16(a0)
ac920010	sw s2, 16(a0)
ac860008	sw a2, 8(a0)
ac9500a0	sw s5, 160(a0)

**TABLE 13-1: PAGE ERASE
OP CODES (CONTINUED)**

Op Code	Instruction
Step 7: All PIC32 devices: Set the NVMADDR register with the address of the Flash page to be erased.	
3c08<ADDR>	lui t0,<FLASH_PAGE_ADDR(31:16)>
3508<ADDR>	ori t0,t0,<FLASH_PAGE_ADDR(15:0)>
ac880020	sw t0,32(a0)
Step 8: All PIC32 devices: Set up the NVMCON register for write operation.	
ac850000	sw a1,0(a0) delay (6 us)
Step 9: PIC32MX devices only: Poll the LVDSTAT register.	
	here1:
8c880000	lw t0,0(a0)
31080800	andi t0,t0,0x0800
1500ffff	bne t0,\$0,here1
00000000	nop
Step 10: All PIC32 devices: Unlock the NVMCON register and start the write operation.	
ac910010	sw s1,16(a0)
ac920010	sw s2,16(a0)
ac860008	sw a2,8(a0)
Step 11: All PIC32 devices: Loop until the WR bit (NVMCON<15>) is clear.	
	here2:
8c880000	lw t0,0(a0)
01064024	and t0,t0,a2
1500ffff	bne t0,\$0,here2
00000000	nop
Step 12: All PIC32 devices: Wait at least 500 ns after the WR bit (NVMCON<15>) clears before writing to any of the NVM registers. This requires inserting a delay in the execution. The programming tools and program executive utilizes the FRC 8 MHz clock. Therefore four NOP instructions equate to 500 ns (see Note 1).	
00000000	nop
00000000	nop
00000000	nop
00000000	nop
Step 13: All PIC32 devices: Clear the WREN bit (NVMCON<14>).	
ac870004	sw a3,4(a0)

PIC32

**TABLE 13-1: PAGE ERASE
OP CODES (CONTINUED)**

Op Code	Instruction
Step 14: PIC32MK family devices only: Check that all data in the page has been erased. If not, adjust the voltage and try again. If all voltages levels have been tried, fail, and go to error procedure.	
ac870004	sw a3, 4(a0)
20171000	addi s7, \$0, 4096
00005020	add t2, \$0, \$0
8c880020	lw t0, 32(a0)
01194020	add t0, t0, t9
	here5:
8d090000	lw t1, 0(t0)
15200005	bne t1, \$0, here6
214a0010	addi t2, t2, 16
11570009	beq t2, s7, here7
00000000	nop
1000fffa	beq \$0, \$0, here5
21080010	addi t0, t0, 16
	here6:
22b50100	addi s5, s5, 256
32b60300	andi s6, s5, 768
16c0ffde	bne s6, \$0, here3
00000000	nop
10000005	beq \$0, \$0, err_proc
00000000	nop
Step 15: PIC32MK family devices only: Restore the NVMCON2 register.	
	here7:
ac9400a0	sw s4, 160(a0)
Step 16: All PIC32 devices: Check the WRERR bit (NVMCON<13>) to ensure that the program sequence has completed successfully. If an error occurs, jump to the error processing routine.	
8c880000	lw t0, 0(a0)
30082000	andi t0, t0, 0x2000
1500<ERR_PROC>	bne t0, \$0, <err_proc_offset>
00000000	nop
<p>Note 1: For programming the Flash at runtime in the users application, the following code is recommended:</p> <pre> while(NVMCON.WR) // waitfor WR bit(NVMCON<15>) to clear {}; { unsigned int start_count = _CP0_GET_COUNT(); unsigned int total_count = (.00000025 * SYSCLK); //count for 500 ns and CPU frequency in MHz while ((_CP0_GET_COUNT()- start_count) < total_count); } </pre>	

14.0 INITIATING A FLASH ROW WRITE

Note: Certain PIC32 devices have available ECC memory. When the ECC feature is used, the Flash memory must be programmed in groups of four 32-bit words using four, 32-bit word alignment. If ECC is dynamically used, the programming method determines when the feature is used. ECC is not enabled for words programmed with the single word programming command. ECC is enabled for words programmed in groups of four, either with the quad word or row programming commands. Failure to adhere to these methods can result in ECC DED errors during run-time. Refer to the specific device data sheet for details regarding ECC use and configuration.

Once a row of data has been downloaded into the device's SRAM, the programming sequence must be initiated to write the block of data to the Flash memory.

See [Table 14-1](#) for the op code and instructions for initiating a Flash row write.

14.1 With the PE

When using the PE, the data is immediately written to the Flash memory from the SRAM. No further action is required.

14.2 Without the PE

Flash memory write operations are controlled by the NVMCON register. Programming is performed by setting the NVMCON register to select the type of write operation and initiating the programming sequence by setting the WR control bit (NVMCON<15>).

FIGURE 14-1: INITIATING FLASH WRITE WITHOUT THE PE

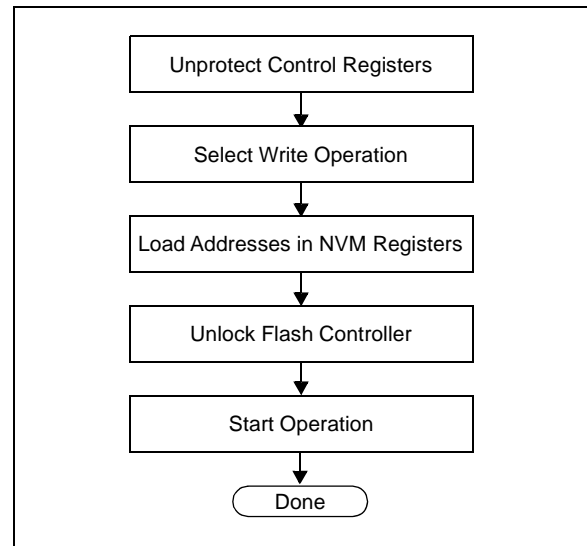

In the Flash write procedure (see [Table 14-1](#)), the Row Programming method is used to program the Flash memory, as it is typically the most expedient. word and Quad Word programming methods are also available, depending on the device, and may be used or required depending on your application. Refer to the “**Flash Program Memory**” chapter in the specific device data sheet and the related section of the “*PIC32 Family Reference Manual*” for more information.

The following steps are required to initiate a Flash write:

1. XferInstruction (op code).
2. Repeat Step 1 until the last instruction is transferred to the CPU.

PIC32

TABLE 14-1: INITIATE FLASH ROW WRITE OP CODES

Op Code	Instruction
Step 1: All PIC32 devices: Initialize constants. Registers a1, a2, and a3 are set for WREN = 1 or NVMOP<3:0> = 0011, WR = 1 and WREN = 1, respectively. Registers s1 and s2 are set for the unlock data values and s0 is initialized to '0'.	
34054003	ori a1,\$0,0x4003
34068000	ori a2,\$0,0x8000
34074000	ori a3,\$0,0x4000
3c11aa99	lui s1,0xaa99
36316655	ori s1,s1,0x6655
3c125566	lui s2,0x5566
365299aa	ori s2,s2,0x99aa
3c100000	lui s0,0x0000
Step 2: PIC32MX devices only: Set register a0 to the base address of the NVM register (0xBF80_F400).	
3c04bf80	lui a0,0xbf80
3484f400	ori a0,a0,0xf400
Step 2: PIC32MK and PIC32MZ family devices only: Set register a0 to the base address of the NVM register (0xBF80_0600). Register s3 is set for the value used to disable write protection in NVMBPB.	
3c04bf80	lui a0,0xbf80
34840600	ori a0,a0,0x0600
34138080	ori s3,\$0,0x8080
Step 3: PIC32MK and PIC32MZ family devices only: Unlock and disable Boot Flash write protection.	
ac910010	sw s1,16(a0)
ac920010	sw s2,16(a0)
ac930090	sw s3,144(a0)
00000000	nop
Step 4: All PIC32 devices: Set the NVMADDR register with the address of the Flash row to be programmed.	
3c08<ADDR>	lui t0,<FLASH_ROW_ADDR(31:16)>
3508<ADDR>	ori t0,t0,<FLASH_ROW_ADDR(15:0)>
ac880020	sw t0,32(a0)
Step 5: PIC32MX devices only: Set the NVMSRCADDR register with the physical source SRAM address (offset is 64).	
3c10<ADDR>	lui s0,<RAM_ADDR(31:16)>
3610<ADDR>	ori s0,s0,<RAM_ADDR(15:0)>
ac900040	sw s0,64(a0)
Step 5: PIC32MK and PIC32MZ family devices only: Set the NVMSRCADDR register with the physical source SRAM address (offset is 112).	
3c10<ADDR>	lui s0,<RAM_ADDR(31:16)>
3610<ADDR>	ori s0,s0,<RAM_ADDR(15:0)>
ac900070	sw s0,112(a0)
Step 6: All PIC32 devices: Set up the NVMCON register for write operation.	
ac850000	sw a1,0(a0)
	delay (6 μ s)

TABLE 14-1: INITIATE FLASH ROW WRITE OP CODES (CONTINUED)

Op Code	Instruction
Step 7: PIC32MX devices only: Poll the LVDSTAT register.	
8c880000 31080800 1500fffd 00000000	here1: lw t0,0(a0) andi t0,t0,0x0800 bne t0,\$0,here1 nop
Step 8: All PIC32 devices: Unlock the NVMCON register and start the write operation.	
ac910010 ac920010 ac860008	sw s1,16(a0) sw s2,16(a0) sw a2,8(a0)
Step 9: All PIC32 devices: Loop until the WR bit (NVMCON<15>) is clear.	
8c880000 01064024 1500fffd 00000000	here2: lw t0,0(a0) and t0,t0,a2 bne t0,\$0,here2 nop
Step 10: All PIC32 devices: Wait at least 500 ns after the WR bit (NVMCON<15>) clears before writing to any of the NVM registers. This requires inserting a delay in the execution. The programming tools and program executive utilizes the FRC 8 MHz clock. Therefore four NOP instructions equate to 500 ns (see Note 1).	
00000000 00000000 00000000 00000000	nop nop nop nop
Step 11: All PIC32 devices: Clear the WREN bit (NVMCONM<14>).	
ac870004	sw a3,4(a0)
Step 12: All PIC32 devices: Check the WRERR bit (NVMCON<13>) to ensure that the program sequence has completed successfully. If an error occurs, jump to the error processing routine.	
8c880000 30082000 1500<ERR_PROC> 00000000	lw t0,0(a0) andi t0,zero,0x2000 bne t0,\$0,<err_proc_offset> nop
Note 1: For programming the Flash at runtime in the users application, the following code is recommended:	
<pre> while (NVMCON.WR) //Wait for WR bit (NVMCON<15>) to clear { { unsigned int start_count = _CP0_GET_COUNT(); unsigned int total_count = (.00000025 * SYSCLK); //count for 500 ns and CPU frequency in MHz while ((_CP0_GET_COUNT()- start_count) < total_count); } } </pre>	

PIC32

15.0 VERIFY DEVICE MEMORY

The verify step involves reading back the code memory space and comparing it with the copy held in the programmer's buffer. The Configuration registers are verified with the rest of the code.

Note: Because the Configuration registers include the device code protection bit, code memory should be verified immediately after writing (if code protection is enabled). This is because the device will not be readable or verifiable if a device Reset occurs after the code-protect bit has been cleared.

15.1 Verifying Memory with the PE

Memory verify is performed using the `GET_CRC` command. Table 17-2 lists the op codes and instructions.

FIGURE 15-1: VERIFYING MEMORY WITH THE PE

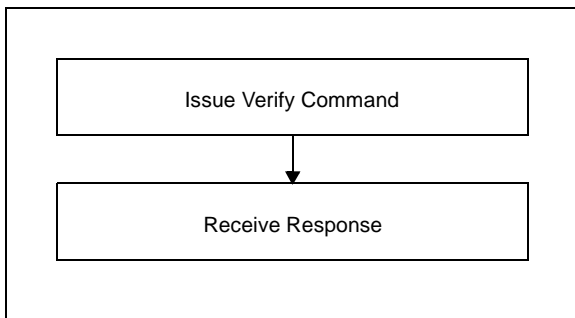

The following steps are required to verify memory using the PE:

1. `XferFastData (GET_CRC)`.
2. `XferFastData (start_Address)`.
3. `XferFastData (length)`.
4. `valCkSum = XferFastData (32'h0x00)`.

Verify that `valCkSum` matches the checksum of the copy held in the programmer's buffer.

15.2 Verifying Memory without the PE

Reading from the Flash memory is performed by executing a series of read accesses from the Fastdata register. Table 20-4 shows the EJTAG programming details, including the address and op code data for performing processor access operations.

FIGURE 15-2: VERIFYING MEMORY WITHOUT THE PE

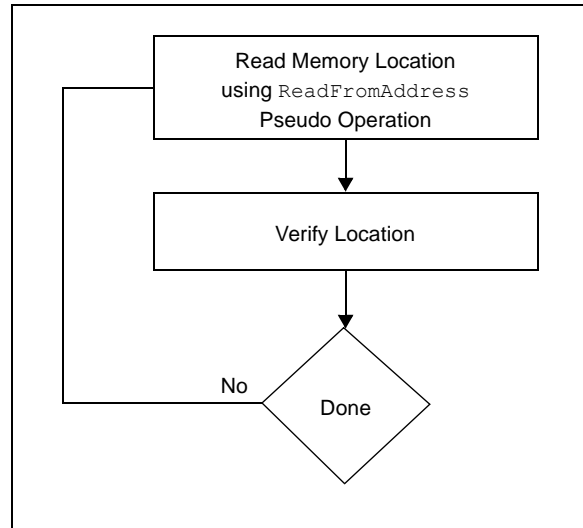

The following steps are required to verify memory:

1. `XferInstruction (op code)`.
2. Repeat Step 1 until the last instruction is transferred to the CPU.
3. Verify that `valRead` matches the copy held in the programmer's buffer.
4. Repeat Steps 1-3 for each memory location.

TABLE 15-1: VERIFY DEVICE OP CODES

Op code	Instruction
Step 1: Initialize some constants.	
3c13ff20	lui s3, 0xFF20
Step 2: Read memory Location.	
3c08<ADDR>	lui t0, <FLASH_WORD_ADDR(31:16)>
3508<ADDR>	ori t0, t0, <FLASH_WORD_ADDR(15:0)>
Step 3: Write to Fastdata location.	
8d090000	lw t1, 0(t0)
ae690000	sw t1, 0(s3)
Step 4: Read data from Fastdata register 0xFF200000.	
Step 5: Repeat Steps 2-4 until all configuration locations are read.	

16.0 EXITING PROGRAMMING MODE

Once a device is programmed, it must be taken out of programming mode to start proper execution of its new program memory contents.

16.1 4-wire Interface

Exiting programming mode is done by removing V_{IH} from the \overline{MCLR} pin, as illustrated in Figure 16-1. The only requirement for exit is that an interval, P16, should elapse between the last clock and program signals before removing V_{IH} .

FIGURE 16-1: 4-WIRE EXIT PROGRAMMING MODE

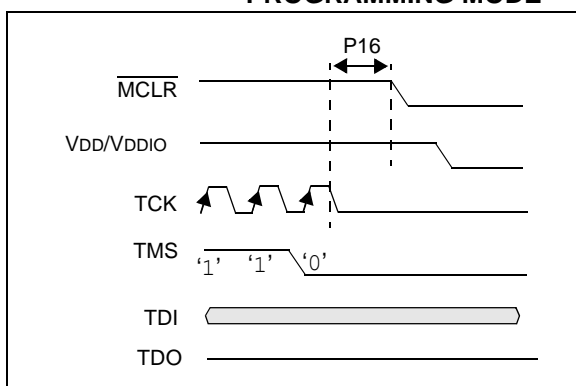

The following steps are required to exit programming mode:

1. SetMode (5'b11111).
2. Assert the \overline{MCLR} pin.
3. Remove power (if the device is powered).

16.2 2-wire Interface

Exiting programming mode is done by removing V_{IH} from the \overline{MCLR} pin, as illustrated in Figure 16-2. The only requirement for exit is that an interval, P16, should elapse between the last clock and program signals on PGECx and PGEDx before removing V_{IH} .

FIGURE 16-2: 2-WIRE EXIT PROGRAMMING MODE

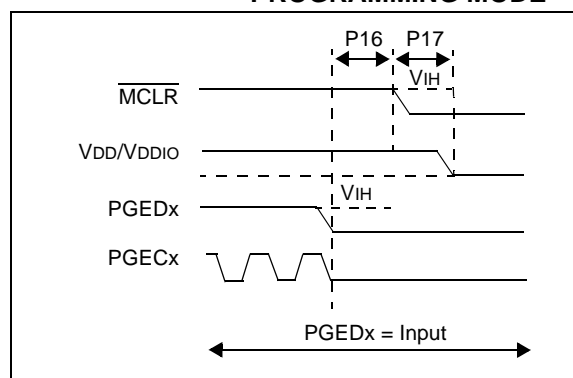

Use the following steps to exit programming mode:

1. SetMode (5'b11111).
2. Assert the \overline{MCLR} pin.
3. Issue a clock pulse on PGECx.
4. Remove power (if the device is powered).

17.0 THE PROGRAMMING EXECUTIVE

Note: The Programming Executive (PE) is included with your installation of MPLAB X IDE. To download the appropriate PE file for your device, please visit the related product page on the Microchip web site (www.microchip.com).

17.1 PE Communication

The programmer and the PE have a master-slave relationship, where the programmer is the master programming device and the PE is the slave.

All communication is initiated by the programmer in the form of a command. The PE is able to receive only one command at a time. Correspondingly, after receiving and processing a command, the PE sends a single response to the programmer.

17.1.1 2-WIRE ICSP EJTAG RATE

In Enhanced ICSP mode, the PIC32 family devices operate from the internal Fast RC oscillator, which has a nominal frequency of 8 MHz.

17.1.2 COMMUNICATION OVERVIEW

The programmer and the PE communicate using the EJTAG Address, Data and Fastdata registers. In particular, the programmer transfers the command and data to the PE using the Fastdata register. The programmer receives a response from the PE using the Address and Data registers. The pseudo operation of receiving a response is shown in the `GetPEResponse` pseudo operation below:

Format:

```
response = GetPEResponse()
```

Purpose:

Enables the programmer to receive the 32-bit response value from the PE.

EXAMPLE 17-1: `GetPEResponse` EXAMPLE

```
WORD GetPEResponse()
{
    WORD response;

    // Wait until CPU is ready
    SendCommand(ETAP_CONTROL);

    // Check if Proc. Access bit (bit 18) is set
    do {
        controlVal=XferData(32'h0x0004C000 );
    } while( PrAcc(contorlVal<18>) is not '1' );

    // Select Data Register
    SendCommand(ETAP_DATA);

    // Receive Response
    response = XferData(0);

    // Tell CPU to execute instruction
    SendCommand(ETAP_CONTROL);
    XferData(32'h0x0000C000);

    // return 32-bit response
    return response;
}
```

The typical communication sequence between the programmer and the PE is shown in [Table 17-1](#).

The sequence begins when the programmer sends the command and optional additional data to the PE, and the PE carries out the command.

When the PE has finished executing the command, it sends the response back to the programmer.

The response may contain more than one response. For example, if the programmer sent a `READ` command, the response will contain the data read.

TABLE 17-1: COMMUNICATION SEQUENCE FOR THE PE

Operation	Operand
Step 1: Send command and optional data from programmer to the PE.	
<code>XferFastData</code>	(Command data len)
<code>XferFastData..</code>	optional data..
Step 2: Programmer reads the response from the PE.	
<code>GetPEResponse</code>	response
<code>GetPEResponse...</code>	response...

17.2 The PE Command Set

Table 17-2 provides PE command set details, such as op code, mnemonic, and short description for each command. Functional details on each command are provided in Section 17.2.3 “ROW_PROGRAM Command” through Section 17.2.14 “CHANGE_CFG Command”.

The PE sends a response to the programmer for each command that it receives. The response indicates if the command was processed correctly. It includes any required response data or error data.

17.2.1 COMMAND FORMAT

All PE commands have a general format consisting of a 32-bit header and any required data for the command, see Figure 17-1. The 32-bit header consists of a 16-bit op code field, which is used to identify the command, and a 16-bit command Operand field. Use of the Operand field varies by command.

Note: Some commands have no Operand information; however, the Operand field must be sent and the programming executive will ignore the data.

FIGURE 17-1: COMMAND FORMAT

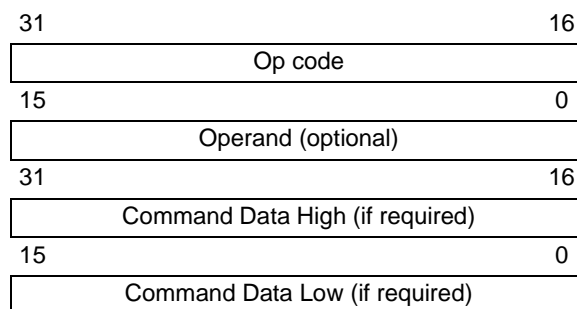

The command in the op code field must match one of the commands in the command set that is listed in Table 17-2. Any command received that does not match a command the list returns a NACK response, as shown in Table 17-3.

The PE uses the command Operand field to determine the number of bytes to read from or to write to. If the value of this field is incorrect, the command is not properly received by the PE.

TABLE 17-2: PE COMMAND SET

Op code	Mnemonic	Description
0x0	ROW_PROGRAM ⁽¹⁾	Program one row of Flash memory at the specified address.
0x1	READ	Read N 32-bit words of memory starting from the specified address (N < 65,536).
0x2	PROGRAM	Program Flash memory starting at the specified address.
0x3	WORD_PROGRAM ⁽³⁾	Program one word of Flash memory at the specified address.
0x4	CHIP_ERASE	Chip Erase of entire chip.
0x5	PAGE_ERASE	Erase pages of code memory from the specified address.
0x6	BLANK_CHECK	Blank Check code.
0x7	EXEC_VERSION	Read the PE software version.
0x8	GET_CRC	Get the CRC of Flash memory.
0x9	PROGRAM_CLUSTER	Programs the specified number of bytes to the specified address.
0xA	GET_DEVICEID	Returns the hardware ID of the device.
0xB	CHANGE_CFG ⁽²⁾	Used by the probe to set various configuration settings for the PE.
0xC	GET_CHECKSUM	Get the checksum of Flash memory.
0xD	QUAD_WORD_PGRM ⁽⁴⁾	Program four words of Flash memory at the specified address.

Note 1: Refer to Table 5-1 for the row size for each device.

2: This command is not available in PIC32MX1XX/2XX devices.

3: On the PIC32MZ family devices, which incorporate ECC, the WORD_PROGRAM command will not generate the ECC parity bits. Reading a location programmed with the WORD_PROGRAM command with ECC enabled will cause a DED fault.

4: This command is available on PIC32MK and PIC32MZ family devices only.

PIC32

17.2.2 RESPONSE FORMAT

The PE response set is shown in [Table 17-3](#). All PE responses have a general format consisting of a 32-bit header and any required data for the response (see [Figure 17-2](#)).

FIGURE 17-2: RESPONSE FORMAT

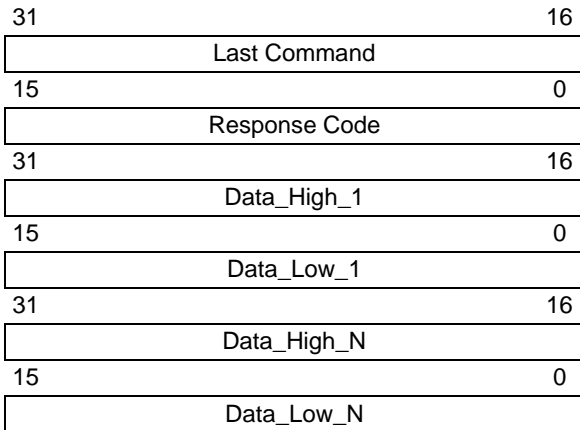

17.2.2.1 Last_Cmd Field

Last_Cmd is a 16-bit field in the first word of the response and indicates the command that the PE processed. It can be used to verify that the PE correctly received the command that the programmer transmitted.

17.2.2.2 Response Code

The response code indicates whether the last command succeeded or failed, or if the command is a value that is not recognized. The response code values are shown in [Table 17-3](#).

TABLE 17-3: RESPONSE VALUES

Op code	Mnemonic	Description
0x0	PASS	Command successfully processed
0x2	FAIL	Command unsuccessfully processed
0x3	NACK	Command not known

17.2.2.3 Optional Data

The response header may be followed by optional data in case of certain commands such as read. The number of 32-bit words of optional data varies depending on the last command operation and its parameters.

17.2.3 ROW_PROGRAM COMMAND

The ROW_PROGRAM command instructs the PE to program a row of data at a specified address.

The data to be programmed to memory, located in command words Data_1 through Data_N, must be arranged using the packed instruction word format provided in [Table 17-4](#) (this command expects an entire row of data).

FIGURE 17-3: ROW_PROGRAM COMMAND

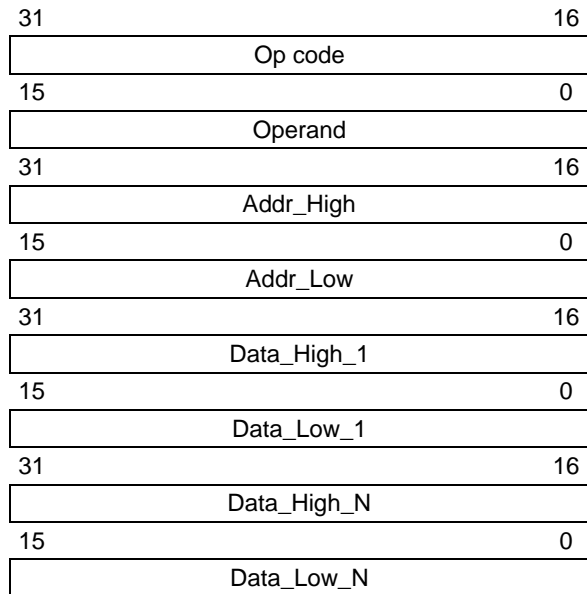
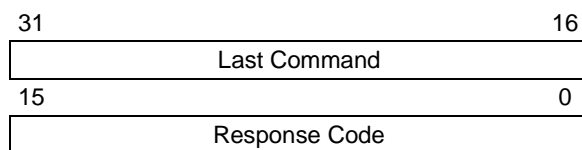

TABLE 17-4: ROW_PROGRAM FORMAT

Field	Description
Op code	0x0
Operand	Not used
Addr_High	High 16 bits of 32-bit destination address
Addr_Low	Low 16 bits of 32-bit destination address
Data_High_1	High 16 bits data word 1
Data_Low_1	Low 16 bits data word 1
Data_High_N	High 16 bits data word 2 through N
Data_Low_N	Low 16 bits data word 2 through N

Expected Response (1 word):

FIGURE 17-4: ROW_PROGRAM RESPONSE



17.2.4 READ COMMAND

The `READ` command instructs the PE to read from memory. The number of 32-bit words specified in the Operand field starting from the 32-bit address specified by the `Addr_Low` and `Addr_High` fields. This command can be used to read Flash memory and Configuration Words. All data returned in response to this command uses the packed data format that is provided in [Table 17-5](#).

FIGURE 17-5: READ COMMAND

31	16
Op code	
15	0
Operand	
31	16
Addr_High	
15	0
Addr_Low	

TABLE 17-5: READ FORMAT

Field	Description
Op code	0x1
Operand	N number of 32-bit words to read (maximum of 65,535)
Addr_Low	Low 16 bits of 32-bit source address
Addr_High	High 16 bits of 32-bit source address

Expected Response:

FIGURE 17-6: READ RESPONSE

31	16
Last Command	
15	0
Response Code	
31	16
Data_High_1	
15	0
Data_Low_1	
31	16
Data_High_N	
15	0
Data_Low_N	

Note: Reading unimplemented memory will cause the PE to Reset. Ensure that only memory locations present on a particular device are accessed.

17.2.5 PROGRAM COMMAND

The `PROGRAM` command instructs the PE to program the Flash memory, including Configuration Words, starting from the 32-bit address specified in the `Addr_Low` and `Addr_High` fields. A 32-bit length field specifies the number of bytes to program.

The address must be aligned to a Flash row size boundary and the length must be a multiple of a Flash row size. See [Table 5-1](#) for the correct row size for the device to be programmed.

FIGURE 17-7: PROGRAM COMMAND

31	16
Op code	
15	0
Operand	
31	16
Addr_High	
15	0
Addr_Low	
31	16
Length_High	
15	0
Length_Low	
31	16
Data_High_1	
15	0
Data_Low_1	
31	16
Data_High_N	
15	0
Data_Low_N	

TABLE 17-6: PROGRAM FORMAT

Field	Description
Op code	0x2
Operand	Not used
Addr_Low	Low 16 bits of 32-bit destination address
Addr_High	High 16 bits of 32-bit destination address
Length_Low	Low 16 bits of Length
Length_High	High 16 bits Length
Data_Low_N	Low 16 bits data word 2 through N
Data_High_N	High 16 bits data word 2 through N

PIC32

The following are three programming scenarios:

- The length of the data to be programmed is the size of a single Flash row
- The length of the data to be programmed is the size of two Flash rows
- The length of the data to be programmed is larger than the size of two Flash rows

When the data length is equal to 512 bytes, the PE receives the 512-byte block of data from the probe and immediately sends the response for this command back to the probe.

The PE will respond for each row of data that it receives. If the data length of the command is equal to a single row, a single PE response is generated. If the data length is equal to two rows, the PE waits to receive both rows of data, and then sends back-to-back responses for each data row. If the data length is greater than two rows of data, the PE will send the response for the first row after receiving the first two rows of data. Subsequent responses are sent after receiving subsequent data row packets. The responses will lag the data by one row. When the last row of data is received, the PE will respond with back-to-back responses for the second-to-last data row followed by the last row.

If the PE encounters an error in programming any of the blocks, it sends a failure status to the probe and aborts the `PROGRAM` command. On receiving the failure status, the probe must stop sending data. The PE will not process any other data for this command from the probe. The process is illustrated in [Figure 17-9](#).

Note: If the `PROGRAM` command fails, the programmer should read the failing row using the `READ` command from the Flash memory. Then the programmer should compare the row received from the Flash memory to its local copy, word-by-word, to determine the address where Flash programming fails.

The response for this command is a little different than the response for other commands. The 16 MSBs of the response contain the 16 LSbs of the destination address, where the last block is programmed. This helps the probe and the PE maintain proper synchronization of sending and receiving data and responses.

Expected Response (1 word):

FIGURE 17-8: `PROGRAM` RESPONSE

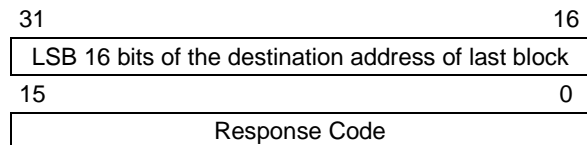
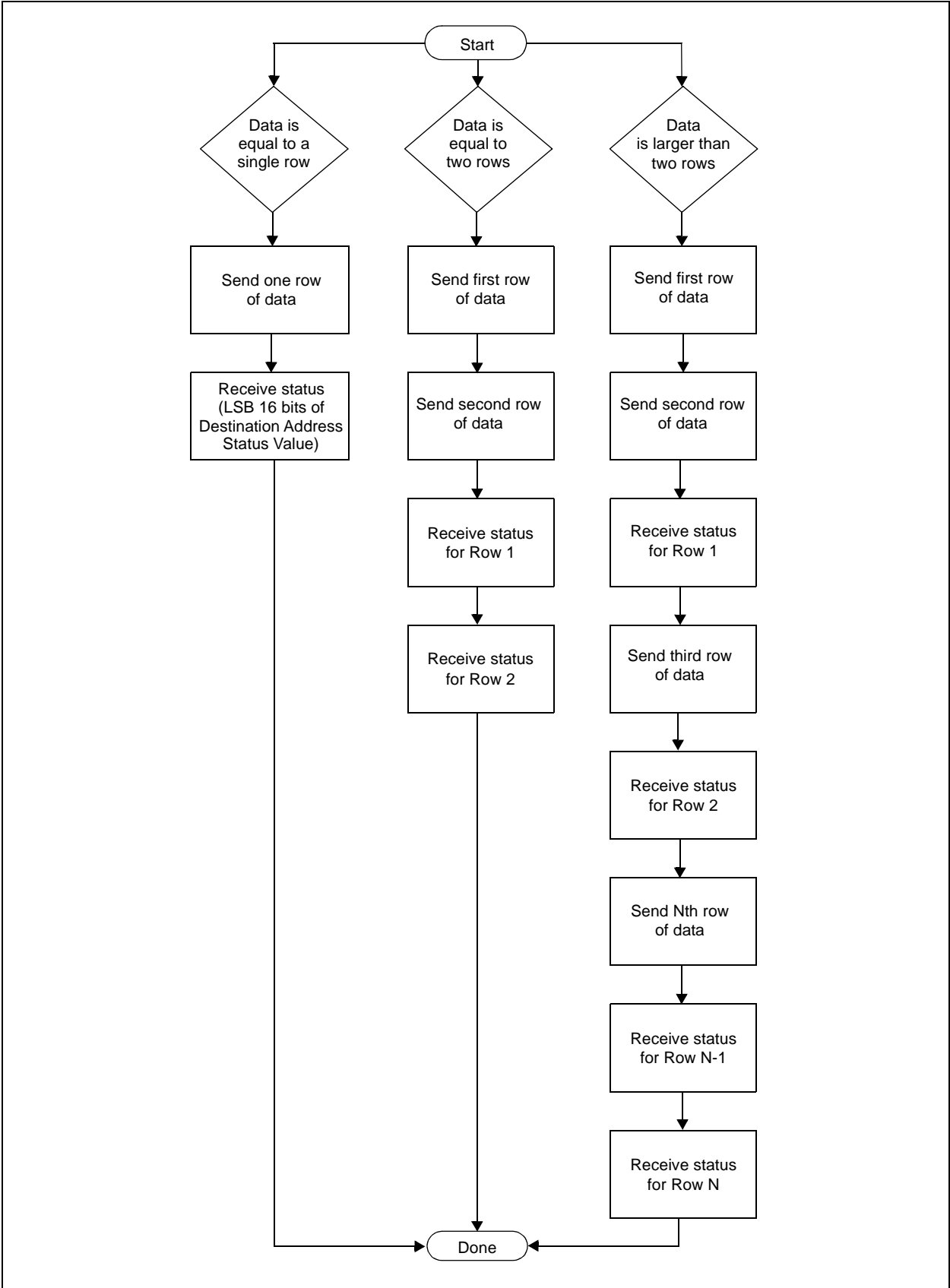

FIGURE 17-9: PROGRAM COMMAND ALGORITHM



PIC32

17.2.6 WORD_PROGRAM COMMAND

The `WORD_PROGRAM` command instructs the PE to program a 32-bit word of data at the specified address.

FIGURE 17-10: WORD_PROGRAM COMMAND

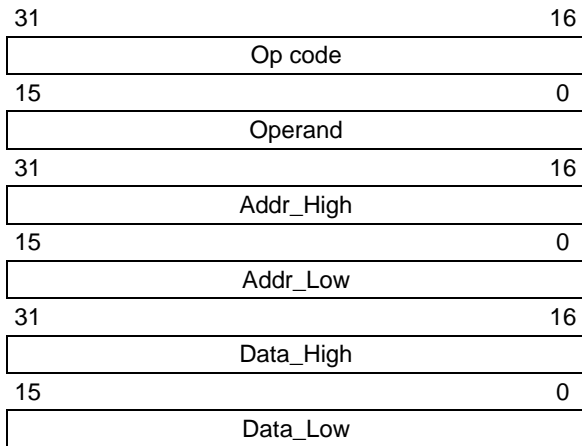
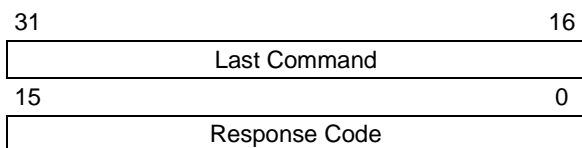

TABLE 17-7: WORD_PROGRAM FORMAT

Field	Description
Op code	0x3
Operand	Not used
Addr_High	High 16 bits of 32-bit destination address
Addr_Low	Low 16 bits of 32-bit destination address
Data_High	High 16 bits data word
Data_Low	Low 16 bits data word

Expected Response (1 word):

FIGURE 17-11: WORD_PROGRAM RESPONSE



17.2.7 CHIP_ERASE COMMAND

The `CHIP_ERASE` command erases the entire chip, including the configuration block.

After the erase is performed, the entire Flash memory contains 0xFFFFFFFF.

FIGURE 17-12: CHIP_ERASE COMMAND

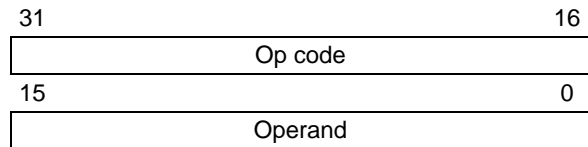
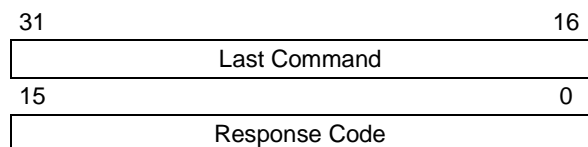

TABLE 17-8: CHIP_ERASE FORMAT

Field	Description
Op code	0x4
Operand	Not used
Addr_Low	Low 16 bits of 32-bit destination address
Addr_High	High 16 bits of 32-bit destination address

Expected Response (1 word):

FIGURE 17-13: CHIP_ERASE RESPONSE



17.2.8 PAGE_ERASE COMMAND

The PAGE_ERASE command erases the specified number of pages of code memory from the specified base address. Depending on the device, the specified base address must be a multiple of 0x400 or 0x100.

After the erase is performed, all targeted words of code memory contain 0xFFFFFFFF.

FIGURE 17-14: PAGE_ERASE COMMAND

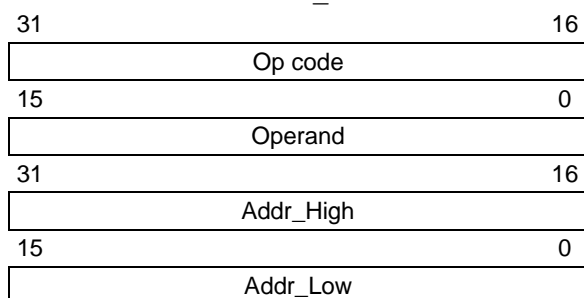
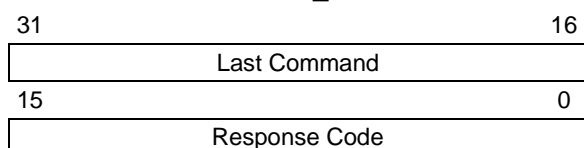

TABLE 17-9: PAGE_ERASE FORMAT

Field	Description
Op code	0x5
Operand	Number of pages to erase
Addr_Low	Low 16 bits of 32-bit destination address
Addr_High	High 16 bits of 32-bit destination address

Expected Response (1 word):

FIGURE 17-15: PAGE_ERASE RESPONSE



17.2.9 BLANK_CHECK COMMAND

The BLANK_CHECK command queries the PE to determine whether the contents of code memory and code-protect Configuration bits (GCP and GWRP) are blank (contains all '1's).

FIGURE 17-16: BLANK_CHECK COMMAND

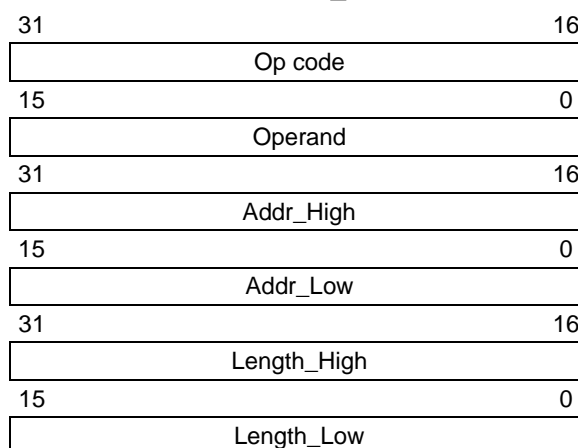
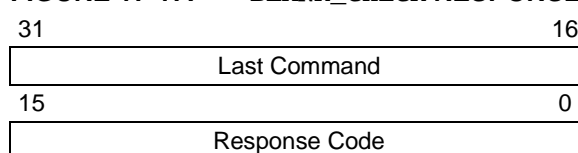

TABLE 17-10: BLANK_CHECK FORMAT

Field	Description
Op code	0x6
Operand	Not used
Address	Address where to start the Blank Check
Length	Number of program memory locations to check in terms of bytes

Expected Response (1 word for blank device):

FIGURE 17-17: BLANK_CHECK RESPONSE



PIC32

17.2.10 EXEC_VERSION COMMAND

EXEC_VERSION queries for the version of the PE software stored in RAM.

FIGURE 17-18: EXEC_VERSION COMMAND

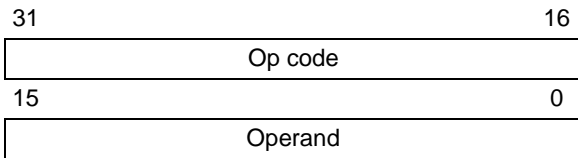
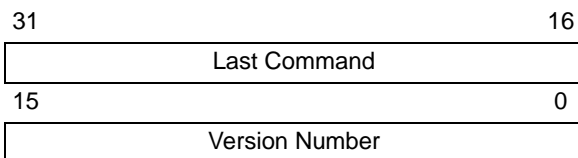

TABLE 17-11: EXEC_VERSION FORMAT

Field	Description
Op code	0x7
Operand	Not used

Expected Response (1 word):

FIGURE 17-19: EXEC_VERSION RESPONSE



17.2.11 GET_CRC COMMAND

GET_CRC calculates the CRC of the buffer from the specified address to the specified length, using the table look-up method. The CRC details are as follows:

- CRC-CCITT, 16-bit
- Polynomial: $X^{16}+X^{12}+X^5+1$, hex 0x00011021
- Seed: 0xFFFF
- Most Significant Byte (MSB) shifted in first

Note 1: In the response, only the CRC Least Significant 16 bits are valid.

2: The PE will automatically determine if the hardware CRC is available and use it by default. The hardware CRC is not used on PIC32MX1XX/2XX devices.

FIGURE 17-20: GET_CRC COMMAND

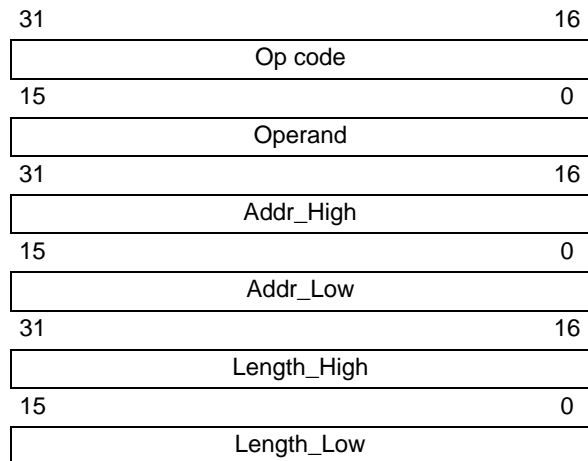
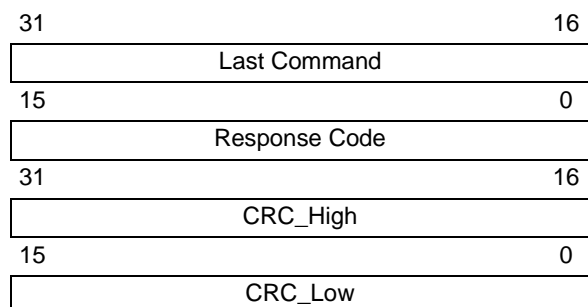

TABLE 17-12: GET_CRC FORMAT

Field	Description
Op code	0x8
Operand	Not used
Address	Address where to start calculating the CRC
Length	Length of buffer on which to calculate the CRC, in number of bytes

Expected Response (2 words):

FIGURE 17-21: GET_CRC RESPONSE



17.2.12 PROGRAM_CLUSTER COMMAND

PROGRAM_CLUSTER programs the specified number of bytes to the specified address. The address must be 32-bit aligned, and the number of bytes must be a multiple of a 32-bit word.

FIGURE 17-22: PROGRAM_CLUSTER COMMAND

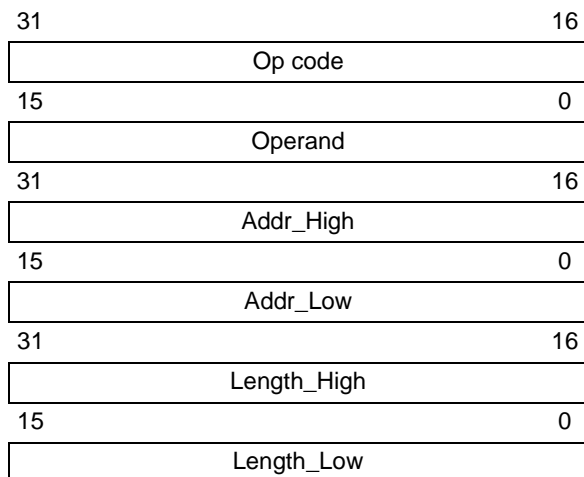

TABLE 17-13: PROGRAM_CLUSTER FORMAT

Field	Description
Op code	0x9
Operand	Not used
Address	Start address for programming
Length	Length of area to program in number of bytes

Note: If the PROGRAM_CLUSTER command fails, the programmer should read the failing row using the READ command from the Flash memory. Then the programmer should compare the row received from the Flash memory to its local copy word-by-word to determine the address where Flash programming fails.

Expected Response (1 word):

FIGURE 17-23: PROGRAM_CLUSTER RESPONSE

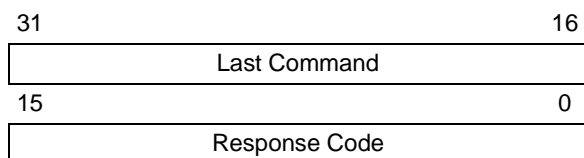

17.2.13 GET_DEVICEID COMMAND

The GET_DEVICEID command returns the hardware ID of the device.

FIGURE 17-24: GET_DEVICEID COMMAND

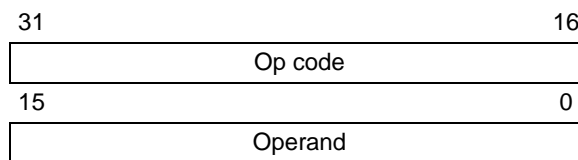
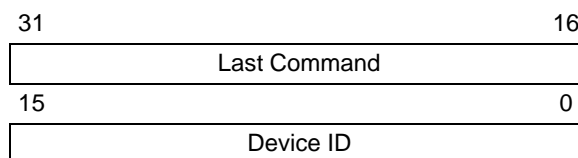

TABLE 17-14: GET_DEVICEID FORMAT

Field	Description
Op code	0xA
Operand	Not used

Expected Response (1 word):

FIGURE 17-25: GET_DEVICEID RESPONSE



PIC32

17.2.14 CHANGE_CFG COMMAND

CHANGE_CFG is used by the probe to set various configuration settings for the PE. Currently, the single configuration setting determines which of the following calculation methods the PE should use:

- Software CRC calculation method
- Hardware calculation method

FIGURE 17-26: CHANGE_CFG COMMAND

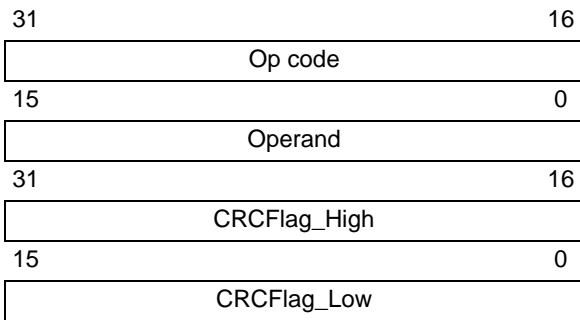
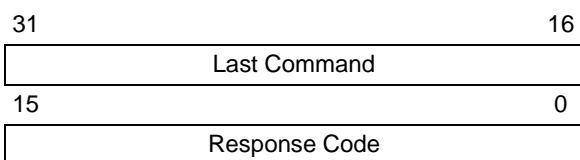

TABLE 17-15: CHANGE_CFG FORMAT

Field	Description
Op code	0xB
Operand	Not used
CRCFlag	If the value is '0', the PE uses the software CRC calculation method. If the value is '1', the PE uses the hardware CRC unit to calculate the CRC.

Expected Response (1 word):

FIGURE 17-27: CHANGE_CFG RESPONSE



Note: The CHANGE_CFG command is not available in PIC32MX1XX/2XX devices.

17.2.15 GET_CHECKSUM COMMAND

GET_CHECKSUM returns the sum of all the bytes starting at the address argument up to the length argument. The result is a 32-bit word.

FIGURE 17-28: CHANGE_CFG COMMAND

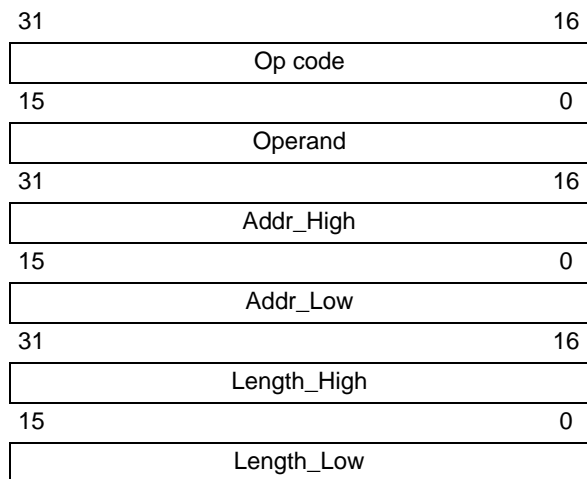
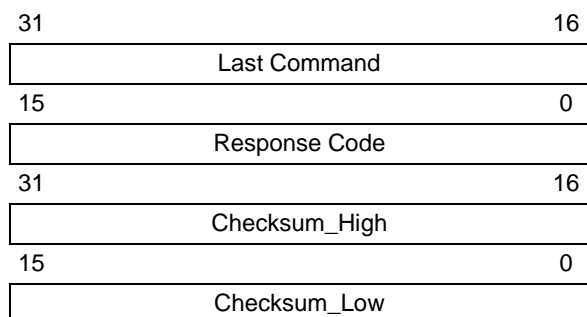

TABLE 17-16: GET_CHECKSUM FORMAT

Field	Description
Op code	0x0C
Operand	Not used
Addr_High	High-order 16 bits of the 32-bit starting address of the data to calculate the checksum for.
Addr_Low	Low-order 16 bits of the 32-bit starting address of the data to calculate the checksum for.
Length_High	High-order 16 bits of the 32-bit length of data to calculate the checksum for in bytes.
Length_Low	Low-order 16 bits of the 32-bit length of data to calculate the checksum for in bytes.

Expected Response (1 word):

FIGURE 17-29: GET_CHECKSUM RESPONSE



17.2.16 QUAD_WORD_PROGRAM COMMAND

QUAD_WORD_PROGRAM instructs the PE to program four, 32-bit words at the specified address. The address must be an aligned four word boundary (bits 0-1 must be '0'). If not, the command will return a FAIL response value and no data will be programmed.

FIGURE 17-30: QUAD_WORD_PROGRAM COMMAND

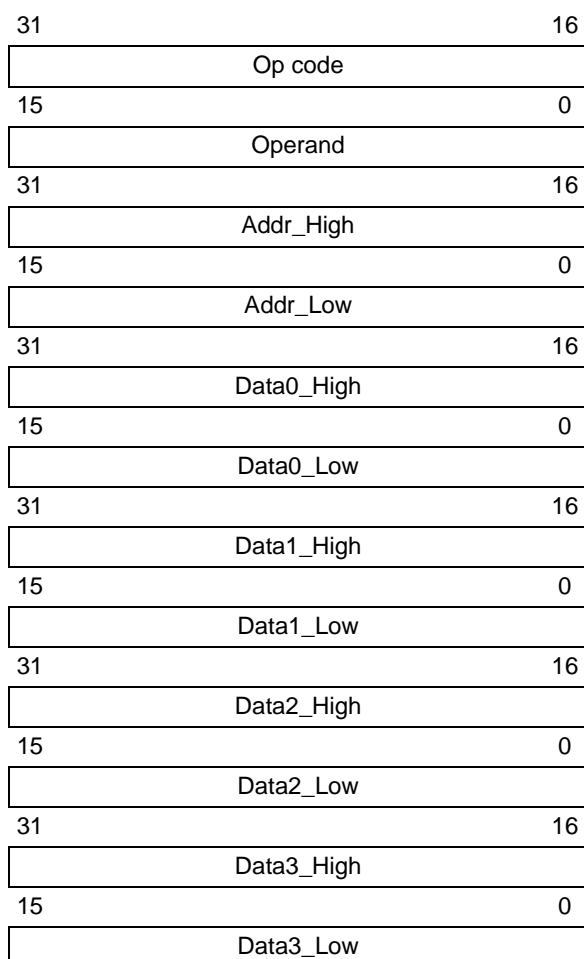

TABLE 17-17: QUAD_WORD_PROGRAM FORMAT

Field	Description
Op code	0x0D
Operand	Not used
Addr_High	High-order 16 bits of the 32-bit starting address.
Addr_Low	Low -order 16 bits of the 32-bit starting address.
Data0_High	High-order 16 bits of data word 0.
Data0_Low	Low-order 16 bits of data word 0.
Data1_High	High-order 16 bits of data word 1.
Data1_Low	Low-order 16 bits of data word 1.

TABLE 17-17: QUAD_WORD_PROGRAM FORMAT

Data2_High	High-order 16 bits of data word 2.
Data2_Low	Low-order 16 bits of data word 2.
Data3_High	High-order 16 bits of data word 3.
Data3_Low	Low-order 16 bits of data word 3.

Expected Response (1 word):

FIGURE 17-31: QUAD_WORD_PROGRAM RESPONSE

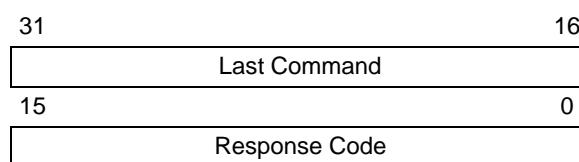

PIC32

18.0 CHECKSUM

18.1 Theory

The checksum is calculated as the 32-bit summation of all bytes (8-bit quantities) in program Flash, Boot Flash (except device Configuration Words), the Device ID register with applicable mask, and the device Configuration Words with applicable masks. Then the 2's complement of the summation is calculated. This final 32-bit number is presented as the checksum.

18.2 Mask Values

The mask value of a device Configuration is calculated by setting all the unimplemented bits to '0' and all the implemented bits to '1'.

For example, [Register 18-1](#) shows the DEVCFG0 register of the PIC32MX360F512L device. The mask value for this register is:

```
mask_value_devcfg0 = 0x110FF00B
```

REGISTER 18-1: DEVCFG0 REGISTER OF PIC32MX360F512L

Bit Range	Bit 31/23/15/7	Bit 30/22/14/6	Bit 29/21/13/5	Bit 28/20/12/4	Bit 27/19/11/3	Bit 26/18/10/2	Bit 25/17/9/1	Bit 24/16/8/0
31:24	r-0	r-1	r-1	R/P-1	r-1	r-1	r-1	R/P-1
	—	—	—	CP	—	—	—	BWP
23:16	r-1	r-1	r-1	r-1	R/P-1	R/P-1	R/P-1	R/P-1
	—	—	—	—	PWP19	PWP18	PWP17	PWP16
15:8	R/P-1	R/P-1	R/P-1	R/P-1	r-1	r-1	r-1	r-1
	PWP15	PWP14	PWP13	PWP12	—	—	—	—
7:0	r-1	r-1	r-1	r-1	R/P-1	r-1	R/P-1	R/P-1
	—	—	—	—	ICESEL	—	DEBUG<1:0>	

Legend:	P = Programmable bit	r = Reserved bit
R = Readable bit	W = Writable bit	U = Unimplemented bit, read as '0'
-n = Value at POR	'1' = Bit is set	'0' = Bit is cleared
		x = Bit is unknown

Table 18-1 lists the mask values of the four device Configuration registers and Device ID registers to be used in the checksum calculations for PIC32MX, PIC32MZ, and PIC32MK devices.

TABLE 18-1: DEVICE CONFIGURATION REGISTER MASK VALUES OF CURRENTLY SUPPORTED PIC32MX, PIC32MZ, AND PIC32MK DEVICES

Device Family	Flash Memory Sizes (KB)	DEVCFG0	DEVCFG1	DEVCFG2	DEVCFG3	DEVCFG4	DEVID
PIC32MX110/120/130/150F0xx PIC32MX150F128 (28/36/44-pin devices only)	16, 32, 64, 128	0x1100FC1F	0x03DFF7A7	0x00070077	0xF000FFFF	—	0x0FFFFFFF
PIC32MX130F128/256 PIC32MX150F256 (28/36/44-pin devices only)	16, 32, 64, 128	0x1100FC1F	0x03DFF7A7	0x00070077	0xF0000000	—	0x0FFFFFFF
PIC32MX 210/220/230/250 (28/36/44-pin devices only)	16, 32, 64, 128	0x1100FC1F	0x03DFF7A7	0x00078777	0xF0000000	—	0x0FFFFFFF
PIC32MX 15X/17X (28/44-pin devices only)	128,256	0x1187F01F	0x03FFF7A7	0xFFB700F7	0x30C00000	—	0x0FFFFFFF
PIC32MX 25X/27X (28/44-pin devices only)	128,256	0x1187F01F	0x03FFF7A7	0xFFB787F7	0x70C00000	—	0x0FFFFFFF
PIC32MX 320/340/360	32, 64, 128, 256, 512	0x110FF00B	0x009FF7A7	0x00070077	0x0000FFFF	—	0x000FF000
PIC32MX 420/440/460	32, 64, 128, 256, 512	0x110FF00B	0x009FF7A7	0x00078777	0x0000FFFF	—	0x000FF000
PIC32MX110/120/130/150F0xx PIC32MX150F128 PIC32MX170F256 (64/100-pin Devices only)	64, 128, 256, 512	0x110FFC1F	0x03DFF7A7	0x00070077	0xF000FFFF	—	0x0FFFFFFF
PIC32MX130F128/256 PIC32MX150F256 PIC32MX170F512 (64/100-pin Devices only)	64, 128, 256, 512	0x110FFC1F	0x03DFF7A7	0x00070077	0xF0000000	—	0x0FFFFFFF
PIC32MX230F0xx PIC32MX250F128 PIC32MX270F256 (64/100-pin Devices only)	64, 128, 256, 512	0x110FFC1F	0x03DFF7A7	0x00078777	0xF000FFFF	—	0x0FFFFFFF

Note 1: Applicable only to PIC32MZ DA family devices.

PIC32

TABLE 18-1: DEVICE CONFIGURATION REGISTER MASK VALUES OF CURRENTLY SUPPORTED PIC32MX, PIC32MZ, AND PIC32MK DEVICES (CONTINUED)

Device Family	Flash Memory Sizes (KB)	DEVCFG0	DEVCFG1	DEVCFG2	DEVCFG3	DEVCFG4	DEVID
PIC32MX230F128 PIC32MX230F256 PIC32MX250F256 PIC32MX270F512 PIC32MX530 PIC32MX550 PIC32MX570 (64/100-pin devices only)	64, 128, 256, 512	0x110FFC1F	0x03DFF7A7	0x00078777	0xF0000000	—	0x0FFFFFFF
PIC32MX 330/350/370	64, 128, 256, 512	0x110FF01F	0x03DFF7A7	0x00070077	0x3007FFFF	—	0x0FFFFFFF
PIC32MX 430/450/470	64, 128, 256, 512	0x110FF01F	0x03DFF7A7	0x00078777	0xF007FFFF	—	0x0FFFFFFF
PIC32MX 534/564	64, 128	0x110FF00F	0x009FF7A7	0x00078777	0xC407FFFF	—	0x0FFFF000
PIC32MX 664	64, 128	0x110FF00F	0x009FF7A7	0x00078777	0xC307FFFF	—	0x0FFFF000
PIC32MK 0512/1024XXD/E/F	512, 1024	0x7FFFFFFF	0xFFFFFFFF	0xFFFFFFFF	0xFFFF0000	—	0x0FFFFFFF
PIC32MK [0512/1024XXK/L/M	512, 1024	0x4BFFF77F	0xFFFFC7FF	0xBFF77FF7	0xF8D0FFFF	0xFF000000	0x0FFFFFFF
PIC32MK 0256/0512XXH/G/J	256, 512	0x4BFFF77F	0xFFFFC7FF	0x3FF77FF7	0x3810FFFF	0xFF000000	0x0FFFFFFF
PIC32MX 764	128	0x110FF00F	0x009FF7A7	0x00078777	0xC707FFFF	—	0x0FFFF000
PIC32MX170F256 (28/36/44-pin devices only)	256	0x1107FC1F	0x03DFF7A7	0x00070077	0xF000FFFF	—	0x0FFFFFFF
PIC32MX170F512 (28/36/44-pin devices only)	256	0x1107FC1F	0x03DFF7A7	0x00070077	0xF0000000	—	0x0FFFFFFF
PIC32MX270F256 (28/36/44-pin devices only)	256	0x1107FC1F	0x03DFF7A7	0x00078777	0xF000FFFF	—	0x0FFFFFFF
PIC32MX270F512 (28/36/44-pin devices only)	256	0x1107FC1F	0x03DFF7A7	0x00078777	0xF0000000	—	0x0FFFFFFF
PIC32MZ 05XX/10XX/20XX	512, 1024, 2048	0x7FFFFFFF	0xFFFFFFFF	0xFFFFFFFF	0xFFFF0000	0xFFFFFFFF (see Note 1)	0x0FFFFFFF
PIC32MX 575	256, 512	0x110FF00F	0x009FF7A7	0x00078777	0xC407FFFF	—	0x000FF000
PIC32MX 675/695	256, 512	0x110FF00F	0x009FF7A7	0x00078777	0xC307FFFF	—	0x000FF000
PIC32MX 775/795	256, 512	0x110FF00F	0x009FF7A7	0x00078777	0xC707FFFF	—	0x000FF000

Note 1: Applicable only to PIC32MZ DA family devices.

18.3 Algorithm

Figure 18-1 illustrates an example of a high-level algorithm for calculating the checksum for a PIC32 device to demonstrate one method to derive a checksum. This is merely an example of how the actual calculations can be accomplished, the method that is ultimately used is left to the discretion of the software developer.

As stated earlier, the PIC32 checksum is calculated as the 32-bit summation of all bytes (8-bit quantities) in program Flash, Boot Flash (except device Configuration Words), the Device ID register with applicable mask, and the device Configuration Words with applicable masks.

Then the 2's complement of the summation is calculated. This final 32-bit number is presented as the checksum.

The mask values of the device Configuration and Device ID registers are derived as described in the previous section, [Section 18.2 "Mask Values"](#).

An arithmetic AND operation of these device Configuration register values is performed with the appropriate mask value, before adding their bytes to the checksum.

Similarly, an arithmetic AND operation of the Device ID register is performed with the appropriate mask value, before adding its bytes to the checksum, see [Section 19.0 "Configuration Memory and Device ID"](#) for more information.

FIGURE 18-1: HIGH-LEVEL ALGORITHM FOR CHECKSUM CALCULATION

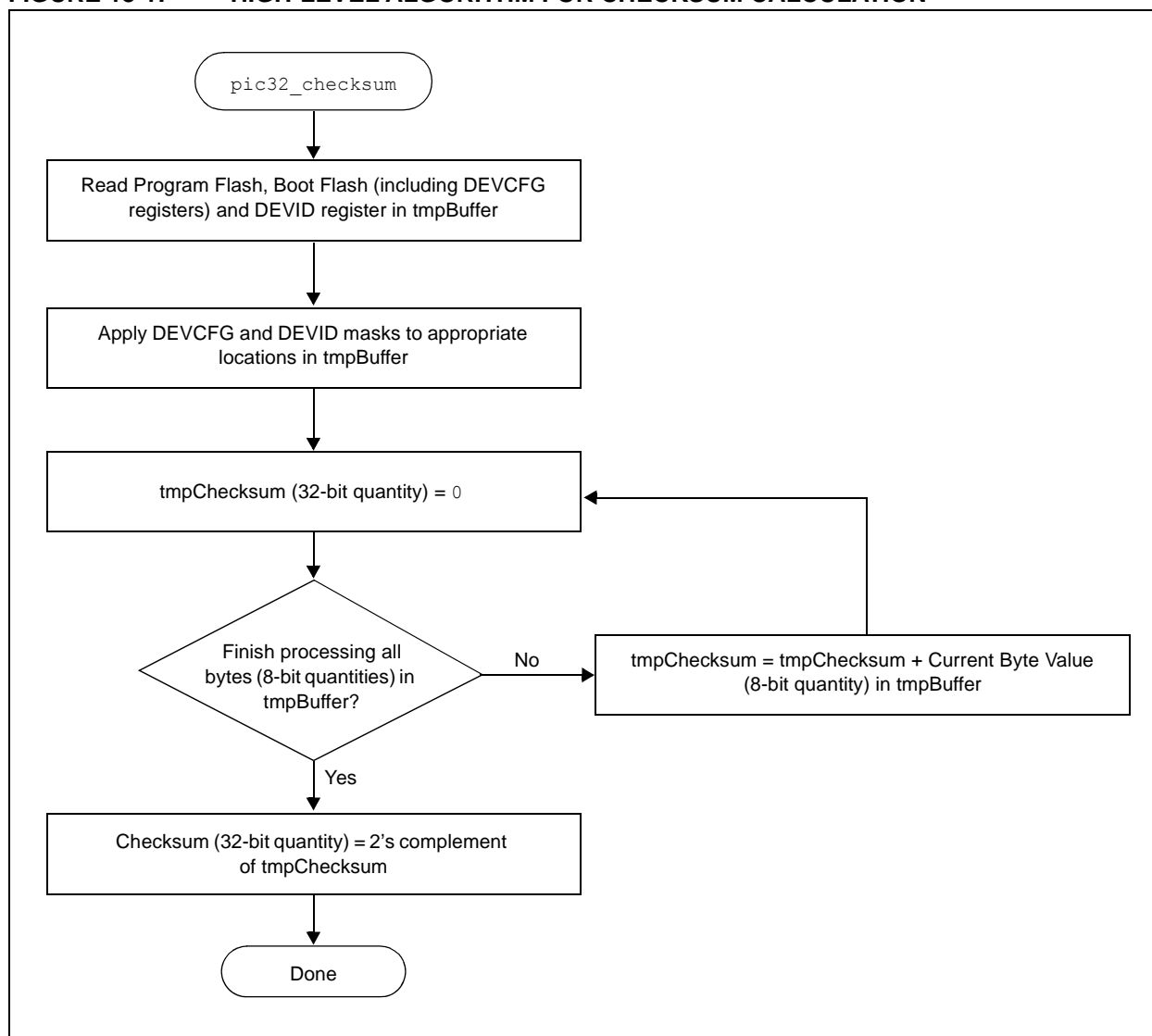

PIC32

The formula to calculate the checksum for a PIC32 device is provided in [Equation 18-1](#).

EQUATION 18-1: CHECKSUM FORMULA

$$\text{Checksum} = 2's \text{ complement } (PF + BF + DCR + DIR)$$

Where,

PF = 32-bit summation of all bytes in Program Flash

BF = 32-bit summation of all bytes in Boot Flash, except device Configuration registers (see **Note 1**)

$$DCR = \sum_{X=0}^y \text{ 32-bit summation of bytes } (MASK_{DEVCFGX} \& DEVCFGx)$$

Where,

$y = 3$ for PIC32MX, PIC32MK, PIC32MZ EC, and PIC32MZ EF family devices

$y = 4$ for all other PIC32MZ family devices

DIR = 32-bit summation of bytes ($MASK_{DEVID}$ & $DEVID$)

$MASK_{DEVCFGX}$ = mask value from [Table 18-1](#)

$MASK_{DEVID}$ = mask value from [Table 18-1](#) (see **Note 2**)

$DEVCP$ = 32-bit summation of bytes ($MASK_{DEVCP}$ & $DEVCP$)

Where,

$MASK_{DEVCP} = 0x10000000$ for PIC32MK

Note 1: For PIC32MZ family devices, the Boot Flash memory that resides at 0x1FCxFF00 through 0x1FCxFFFF is not summed, as these memory locations contain the device configuration and CP values. For PIC32MK family devices, the Boot Flash memory that resides at 0x1FC03F00 through 0x1FC03FFF is not summed.

2: For PIC32MZ and PIC32MK family devices, the checksum calculated in MPLAB X IDE only uses the primary DEVCFGx registers. Neither the alternate nor second Boot Flash (if available) registers are calculated.

18.4 Example of Checksum Calculation

The following five sections demonstrate a checksum calculation for the PIC32MX360F512L device using [Equation 18-1](#).

The following assumptions are made for the purpose of this checksum calculation example:

- Program Flash and Boot Flash are in the erased state (all bytes are 0xFF)
- Device Configuration is in the default state of the device (no configuration changes are made)

Each item on the right side of the equation (PF, BF, DCR, DIR) is individually calculated. After deriving the values, the final value of the checksum can be calculated.

18.4.1 CALCULATING FOR “PF” IN THE CHECKSUM FORMULA

The size of Program Flash is 512 KB, which equals 524288 bytes. Since the program Flash is assumed to be in erased state, the value of PF is resolved through the following calculation:

$$PF = 0xFF + 0xFF + \dots 524288 \text{ times}$$

$$PF = 0x7F80000 \text{ (32-bit number)}$$

18.4.2 CALCULATING FOR “BF” IN THE CHECKSUM FORMULA

The size of the Boot Flash is 12 KB, which equals 12288 bytes. However, the last 16 bytes are device Configuration registers, which are treated separately. Therefore, the number of bytes in Boot Flash that we consider in this step is 12272. Since the Boot Flash is assumed to be in erased state, the value of “BF” is resolved through the following calculation:

$$BF = 0xFF + 0xFF + \dots 12272 \text{ times}$$

$$BF = 0x002FC010 \text{ (32-bit number)}$$

18.4.3 CALCULATING FOR “DCR” IN THE CHECKSUM FORMULA

Since the device Configuration registers are left in their default state, the value of the appropriate DEVCFG register – as read by the PIC32 core, its respective mask value, the value derived from applying the mask, and the 32-bit summation of bytes (all as shown in [Table 18-2](#)) provide the total of the 32-bit summation of bytes.

From [Table 18-2](#), the value of “DCR” is:

$$DCR = 0x000003D6 \text{ (32-bit number)}$$

TABLE 18-2: DCR CALCULATION EXAMPLE

Register	POR Default Value	Mask	POR Default Value & Mask	32-Bit Summation of Bytes
DEVCFG0	0x7FFFFFFF	0x110FF00B	0x110FF00B	0x0000011B
DEVCFG1	0xFFFFFFFF	0x009FF7A7	0x009FF7A7	0x0000023D
DEVCFG2	0xFFFFFFFF	0x00070077	0x00070077	0x0000007E
DEVCFG3	0xFFFFFFFF	0x00000000	0x00000000	0x00000000
Total of the 32-bit Summation of Bytes =				0x000003D6

PIC32

18.4.4 CALCULATING FOR “DIR” IN THE CHECKSUM FORMULA

The value of Device ID register and its mask value, the value derived from applying the mask, and the 32-bit summation of bytes are shown in [Table 18-3](#).

From [Table 18-3](#), the value of “DIR” is:

DIR = 0x00000083 (32-bit number.)

TABLE 18-3: DIR CALCULATION EXAMPLE

Register	POR Default Value	Mask	POR Default Value & Mask	32-Bit Summation of Bytes
DEVID	0x00938053	0x000FF000	0x00038000	0x00000083

18.4.5 COMPLETING THE PIC32 CHECKSUM CALCULATION

The values derived in previous sections (PF, BF, DCR, DIR) are used to calculate the checksum value. Perform the 32-bit summation of the PF, BF, DCR and DIR as derived in previous sections and store it in a variable, called *temp*, as shown in [Example 18-1](#).

EXAMPLE 18-1: CHECKSUM CALCULATION PROCESS

1. First, $temp = PF + BF + DCR + DIR$, which translates to:
 $temp = 0x7F80000 + 0x002FC010 + 0x000003D6 + 0x00000083$
2. Adding all four values results in *temp* being equal to 0x0827C469
3. Finally, the 2's complement of *temp* is the checksum:
Checksum = 2's complement (*temp*), which is Checksum = (1's complement (*temp*)) + 1, resulting in 0xF7D83B97

18.4.6 CHECKSUM VALUES WHILE DEVICE IS CODE-PROTECTED

Since the device Configuration Words are not readable while the PIC32 devices are in code-protected state, the checksum values are zeros for all devices.

19.0 CONFIGURATION MEMORY AND DEVICE ID

PIC32 devices include several features intended to maximize application flexibility and reliability, and minimize cost through elimination of external components. These features are configurable through specific Configuration bits for each device.

Refer to the “**Special Features**” chapter in the specific device data sheet for a full list of available features, Configuration bits, and the Device ID register.

Refer to [Appendix C: “Device IDs”](#) to locate the Device ID for a particular PIC32MX, PIC32MZ, or PIC32MK family of devices.

For the current silicon revision and revision ID for a particular device, refer to the related Family Silicon Errata and Data Sheet Clarification. These documents are available for download from the Microchip web site: <http://www.microchip.com/PIC32> and navigating to: [Documentation > Errata](#).

19.1 Device Configuration

In PIC32 devices, the Configuration Words select various device configurations that are set at device Reset prior to execution of any code. These values are located at the highest locations of the Boot Flash Memory (BFM) and since they are part of the program memory, are included in the programming file along with executable code and program constants. The names and locations of these Configuration Words are listed in [Table 19-1](#) through [Table 19-4](#).

Additionally, [Table 19-3](#) and [Table 19-4](#) include Configuration Words for PIC32MZ and PIC32MK family devices, respectively, with dual boot and dual panel Flash. Refer to [Section 48. “Memory Organization and Permissions”](#) (DS60001214) of the “*PIC32 Family Reference Manual*” for a detailed description of the dual boot regions.

TABLE 19-1: DEVCFG LOCATIONS FOR 15X/17X/25X/27X AND PIC32MX3XX/4XX/5XX/6XX/7XX DEVICES ONLY

Configuration Word	Physical Address
DEVCFG0	0x1FC02FFC
DEVCFG1	0x1FC02FF8
DEVCFG2	0x1FC02FF4
DEVCFG3	0x1FC02FF0

TABLE 19-2: DEVCFG LOCATIONS FOR 28/36/44-PIN PIC32MX1XX/2XX AND 64/100-PIN PIC32MX1XX/2XX/5XX DEVICES ONLY

Configuration Word	Physical Address
DEVCFG0	0x1FC00BFC
DEVCFG1	0x1FC00BF8
DEVCFG2	0x1FC00BF4
DEVCFG3	0x1FC00BF0

On Power-on Reset (POR) or any Reset, the Configuration Words are copied from the Boot Flash memory to their corresponding Configuration registers. A Configuration bit can only be programmed = 0 (unprogrammed state = 1).

During programming, a Configuration Word can be programmed a maximum of two times for PIC32MX devices and only one time for PIC32MZ, and PIC32MK family devices before a page erase must be performed.

After programming the Configuration Words, a device Reset will cause the new values to be loaded into the Configuration registers. Because of this, the programmer should program the Configuration Words just prior to verification of the device. The final step is programming the code protection Configuration Word.

These Configuration Words determine the oscillator source. If using the 2-wire Enhanced ICSP mode the Configuration Words are ignored and the device will always use the FRC; however, in 4-wire mode this is not the case. If an oscillator source is selected by the Configuration Words that is not present on the device after Reset, the programmer will not be able to perform Flash operations on the device after it is Reset. See the “**Special Features**” chapter in the specific device data sheet for details regarding oscillator selection using the Configuration Words.

PIC32

TABLE 19-3: CONFIGURATION WORD LOCATIONS FOR PIC32MZ FAMILY DEVICES

Configuration Word (see Note 1)	Register Physical Address			
	Fixed Boot Region 1	Fixed Boot Region 2	Active Boot Alias Region (see Note 2)	Inactive Boot Alias Region (see Note 2)
Boot Sequence Number	0x1FC4FFF0	0x1FC6FFF0	0x1FC0FFF0	0x1FC2FFF0
Code Protection	0x1FC4FFD0	0x1FC6FFD0	0x1FC0FFD0	0x1FC2FFD0
DEVCFG0	0x1FC4FFCC	0x1FC6FFCC	0x1FC0FFCC	0x1FC2FFCC
DEVCFG1	0x1FC4FFC8	0x1FC6FFC8	0x1FC0FFC8	0x1FC2FFC8
DEVCFG2	0x1FC4FFC4	0x1FC6FFC4	0x1FC0FFC4	0x1FC2FFC4
DEVCFG3	0x1FC4FFC0	0x1FC6FFC0	0x1FC0FFC0	0x1FC2FFC0
DEVCFG4 (see Note 3)	0x1FC4FFBC	0x1FC6FFBC	0x1FC0FFBC	0x1FC2FFBC
Alternate Boot Sequence Number	0x1FC4FF70	0x1FC6FF70	0x1FC0FF70	0x1FC2FF70
Alternate Code Protection	0x1FC4FF50	0x1FC6FF50	0x1FC0FF50	0x1FC2FF50
Alternate DEVCFG0	0x1FC4FF4C	0x1FC6FF4C	0x1FC0FF4C	0x1FC2FF4C
Alternate DEVCFG1	0x1FC4FF48	0x1FC6FF48	0x1FC0FF48	0x1FC2FF48
Alternate DEVCFG2	0x1FC4FF44	0x1FC6FF44	0x1FC0FF44	0x1FC2FF44
Alternate DEVCFG3	0x1FC4FF40	0x1FC6FF40	0x1FC0FF40	0x1FC2FF40
Alternate DEVCFG4 (see Note 3)	0x1FC4FF3C	0x1FC6FF3C	0x1FC0FF3C	0x1FC2FF3C

- Note 1:** All values in the 0x1FCxFF00-0x1FCxFFF memory regions should be programmed using the `QUAD_WORD_PROGRAM` command to ensure proper ECC configuration. Refer to [Section 17.2.16 “QUAD_WORD_PROGRAM Command”](#) for details.
- 2:** Active/Inactive boot alias selections are assumed for an unprogrammed device where Fixed Region 1 is active and Fixed Region 2 is inactive. Refer to [Section 48. “Memory Organization and Permissions”](#) (DS60001214) for a detailed description of the alias boot regions.
- 3:** These Configuration Words are available only on PIC32MZ DA family devices.

TABLE 19-4: CONFIGURATION WORD LOCATIONS FOR PIC32MKXXXXXD/E/FXX FAMILY DEVICES

Configuration Word (see Note 1)	Register Physical Address			
	Fixed Boot Region 1	Fixed Boot Region 2	Active Boot Alias Region (see Note 2)	Inactive Boot Alias Region (see Note 2)
Boot Sequence Number	0x1FC43FF0	0x1FC63FF0	0x1FC03FF0	0x1FC23FF0
Code Protection	0x1FC43FD0	0x1FC63FD0	0x1FC03FD0	0x1FC23FD0
DEVCFG0	0x1FC43FCC	0x1FC63FCC	0x1FC03FCC	0x1FC23FCC
DEVCFG1	0x1FC43FC8	0x1FC63FC8	0x1FC03FC8	0x1FC23FC8
DEVCFG2	0x1FC43FC4	0x1FC63FC4	0x1FC03FC4	0x1FC23FC4
DEVCFG3	0x1FC43FC0	0x1FC63FC0	0x1FC03FC0	0x1FC23FC0

- Note 1:** If the device has ECC memory, each of the following Configuration Word Groups should be programmed using the `QUAD_WORD_PROGRAM` command:
- Boot Sequence Number (single quad word programming operation)
 - Code Protection (single quad word programming operation)
 - DEVCFG3, DEVCFG2, DEVCFG1, and DEVCFG0 (single quad word programming operation)
- 2:** Active/Inactive boot alias selections are assumed for an unprogrammed device where Fixed Region 1 is active and Fixed Region 2 is inactive. Refer to the [Section 48. “Memory Organization and Permissions”](#) (DS60001214) for a detailed description of the alias boot regions.

TABLE 19-5: CONFIGURATION WORD LOCATIONS FOR PIC32MKXXXXXXH/G/J/K/L/MXX FAMILY DEVICES

Configuration Word (see Note 1)	Register Physical Address			
	Fixed Boot Region 1	Fixed Boot Region 2	Active Boot Alias Region (see Notes 2, 3)	Inactive Boot Alias Region (see Notes 2, 3)
Boot Sequence Number	0x1FC43FF0	0x1FC63FF0	0x1FC03FF0	0x1FC23FF0
Code Protection	0x1FC43FD0	0x1FC63FD0	0x1FC03FD0	0x1FC23FD0
DEVCFG0	0x1FC43FCC	0x1FC63FCC	0x1FC03FCC	0x1FC23FCC
DEVCFG1	0x1FC43FC8	0x1FC63FC8	0x1FC03FC8	0x1FC23FC8
DEVCFG2	0x1FC43FC4	0x1FC63FC4	0x1FC03FC4	0x1FC23FC4
DEVCFG3	0x1FC43FC0	0x1FC63FC0	0x1FC03FC0	0x1FC23FC0
DEVCFG4	0x1FC43FBC			
Alternate Boot Sequence Number	0x1FC43F70	0x1FC63F70	0x1FC03F70	0x1FC23F70
Alternate Code Protection	0x1FC43F50	0x1FC63F50	0x1FC03F50	0x1FC23F50
Alternate DEVCFG0	0x1FC43F4C	0x1FC63F4C	0x1FC03F4C	0x1FC23F4C
Alternate DEVCFG1	0x1FC43F48	0x1FC63F48	0x1FC03F48	0x1FC23F48
Alternate DEVCFG2	0x1FC43F44	0x1FC63F44	0x1FC03F44	0x1FC23F44
Alternate DEVCFG3	0x1FC43F40	0x1FC63F40	0x1FC03F40	0x1FC23F40
Alternate DEVCFG4	0x1FC43F3C	0x1FC63F3C	0x1FC03F3C	0x1FC23F3C

Note 1: If the device has ECC memory, each of the following Configuration Word Groups should be programmed using the `QUAD_WORD_PROGRAM` command:

- Boot Sequence Number (single quad word programming operation)
 - Code Protection (single quad word programming operation)
 - DEVCFG3, DEVCFG2, DEVCFG1, and DEVCFG0 (single quad word programming operation)
- 2:** All values in the 0x1FCxFF00-0x1FCxFFFF memory regions should be programmed using the `QUAD_WORD_PROGRAM` command to ensure proper ECC configuration. Refer to the [Section 17.2.16 “QUAD_WORD_PROGRAM Command”](#) for details.
- 3:** Active or Inactive boot alias selections are assumed for an unprogrammed device where Fixed Region 1 is active and Fixed Region 2 is inactive. Refer to the [Section 48. “Memory Organization and Permissions”](#) (DS60001214) for a detailed description of the alias boot regions.

PIC32

19.1.1 CONFIGURATION REGISTER PROTECTION

To prevent inadvertent Configuration bit changes during code execution, all programmable Configuration bits are write-once. After a bit is initially programmed during a power cycle, it cannot be written to again. Changing a device configuration requires changing the Configuration data in the Boot Flash memory, and cycling power to the device.

To ensure integrity of the 128-bit data, a comparison is made between each Configuration bit and its stored complement continuously. If a mismatch is detected, a Configuration Mismatch Reset is generated, which causes a device Reset.

19.2 Device Code Protection bit (CP)

The PIC32 family of devices feature code protection, which when enabled, prevents reading of the Flash memory by an external programming device. Once code protection is enabled, it can only be disabled by erasing the device with the Chip Erase command (`MCHP_ERASE`).

When programming a device that has opted to utilize code protection, the programming device must perform verification prior to enabling code protection. Enabling code protection should be the last step of the programming process. Location of the code protection enable bits vary by device. Refer to the “**Special Features**” chapter in the specific device data sheet for details.

<p>Note: Once code protection is enabled, the Flash memory can no longer be read and can only be disabled by an external programmer using the Chip Erase Command (<code>MCHP_ERASE</code>).</p>
--

19.3 Program Write Protection bits (PWP)

The PIC32 families of devices include write protection features, which prevent designated boot and program Flash regions from being erased or written during program execution.

In PIC32MX devices, write protection is implemented in Configuration memory by the Device Configuration Words, while in PIC32MZ and PIC32MK family devices, this feature is implemented through SFRs in the Flash controller.

When write protection is implemented by Device Configuration Words, the write protection register should only be written when all boot and program Flash memory has been programmed. Refer to the “**Special Features**” chapter in the specific device data sheet for details.

If write protection is implemented using SFRs, certain steps may be required during initialization of the device by the external programmer prior to programming Flash regions. Refer to the “**Flash Program Memory**” chapter in the specific device data sheet for details.

20.0 TAP CONTROLLERS

TABLE 20-1: MCHP TAP INSTRUCTIONS

Command	Value	Description
MTAP_COMMAND	5'h0x07	TDI and TDO connected to MCHP Command Shift register (See Table 20-2)
MTAP_SW_MTAP	5'h0x04	Switch TAP controller to MCHP TAP controller
MTAP_SW_ETAP	5'h0x05	Switch TAP controller to EJTAG TAP controller
MTAP_IDCODE	5'h0x01	Select Chip Identification Data register

20.1 Microchip TAP Controllers (MTAP)

20.1.1 MTAP_COMMAND INSTRUCTION

MTAP_COMMAND selects the MCHP Command Shift register. See [Table 20-2](#) for available commands.

20.1.1.1 MCHP_STATUS INSTRUCTION

MCHP_STATUS returns the 8-bit Status value of the Microchip TAP controller. [Table 20-3](#) provides the format of the Status value returned.

20.1.1.2 MCHP_ASSERT_RST INSTRUCTION

MCHP_ASSERT_RST performs a persistent device Reset. It is similar to asserting and holding the MCLR pin. Its associated Status bit is DEVRST.

20.1.1.3 MCHP_DE_ASSERT_RST INSTRUCTION

MCHP_DE_ASSERT_RST removes the persistent device Reset. It is similar to deasserting the MCLR pin. Its associated Status bit is DEVRST.

20.1.1.4 MCHP_ERASE INSTRUCTION

MCHP_ERASE performs a Chip Erase. The CHIP_ERASE command sets an internal bit that requests the Flash Controller to perform the erase. Once the controller becomes busy, as indicated by FCBUSY (Status bit), the internal bit is cleared.

20.1.1.5 MCHP_FLASH_ENABLE INSTRUCTION

MCHP_FLASH_ENABLE sets the FAEN bit, which controls processor accesses to the Flash memory. The FAEN bit's state is returned in the field of the same name. This command has no effect if CPS = 0. This command requires a NOP to complete.

Note: This command is not required for PIC32MZ and PIC32MK family devices.

20.1.1.6 MCHP_FLASH_DISABLE INSTRUCTION

MCHP_FLASH_DISABLE clears the FAEN bit which controls processor accesses to the Flash memory. The FAEN bit's state is returned in the field of the same name. This command has no effect if CPS = 0. This command requires a NOP to complete.

Note: This command is not required for PIC32MZ and PIC32MK family devices.

20.1.2 MTAP_SW_MTAP INSTRUCTION

MTAP_SW_MTAP switches the TAP instruction set to the MCHP TAP instruction set.

Each of these commands should be followed with a SetMode (6'b011111) to force the Chip TAP controller to the Run Test/Idle state.

20.1.3 MTAP_SW_ETAP INSTRUCTION

MTAP_SW_ETAP effectively switches the TAP instruction set to the EJTAG TAP instruction set. It does this by holding the EJTAG TAP controller in the Run Test/Idle state until a MTAP_SW_ETAP instruction is decoded by the MCHP TAP controller.

Each of these commands should be followed with a SetMode (6'b011111) to force the Chip TAP controller to the Run Test/Idle state.

20.1.4 MTAP_IDCODE INSTRUCTION

MTAP_IDCODE returns the value stored in the DEVID register.

PIC32

TABLE 20-2: MTAP_COMMAND DR COMMANDS

Command	Value	Description
MCHP_STATUS	8'h0x00	NOP and return Status.
MCHP_ASSERT_RST	8'h0xD1	Requests the Reset controller to assert device Reset.
MCHP_DE_ASSERT_RST	8'h0xD0	Removes the request for device Reset, which causes the reset controller to deassert device Reset if there is no other source requesting Reset (i.e., MCLR).
MCHP_ERASE	8'h0xFC	Cause the Flash controller to perform a Chip Erase.
MCHP_FLASH_ENABLE ⁽¹⁾	8'h0xFE	Enables fetches and loads to the Flash (from the processor).
MCHP_FLASH_DISABLE ⁽¹⁾	8'h0xFD	Disables fetches and loads to the Flash (from the processor).

Note 1: This command is not required for PIC32MK and PIC32MZ family of devices.

TABLE 20-3: MCHP STATUS VALUE

Bit Range	Bit 7	Bit 6	Bit 5	Bit 4	Bit 3	Bit 2	Bit 1	Bit 0
7:0	CPS	0	NVMERR ⁽¹⁾	0	CFGRDY	FCBUSY	FAEN ⁽²⁾	DEVST

- bit 7 **CPS:** Code-Protect State bit
1 = Device is not code-protected
0 = Device is code-protected
- bit 6 **Unimplemented:** Read as '0'
- bit 5 **NVMERR:** NVMCON Status bit⁽¹⁾
1 = An Error occurred during NVM operation
0 = An Error did not occur during NVM operation
- bit 4 **Unimplemented:** Read as '0'
- bit 3 **CFGRDY:** Code-Protect State bit
1 = Configuration has been read and CP is valid
0 = Configuration has not been read
- bit 2 **FCBUSY:** Flash Controller Busy bit
1 = Flash controller is busy (Erase is in progress)
0 = Flash controller is not busy (either erase has not started or it has finished)
- bit 1 **FAEN:** Flash Access Enable bit⁽²⁾
This bit reflects the state of CFGCON.FAEN.
1 = Flash access is enabled
0 = Flash access is disabled (i.e., processor accesses are blocked)
- bit 0 **DEVST:** Device Reset State bit
1 = Device Reset is active
0 = Device Reset is not active

Note 1: This bit is not implemented in PIC32MX320/340/360/420/440/460 devices.

2: This bit is not implemented in PIC32MK and PIC32MZ family devices.

TABLE 20-4: EJTAG TAP INSTRUCTIONS

Command	Value	Description
ETAP_ADDRESS	5'h0x08	Select Address register.
ETAP_DATA	5'h0x09	Select Data register.
ETAP_CONTROL	5'h0x0A	Select EJTAG Control register.
ETAP_EJTAGBOOT	5'h0x0C	Set EhtagBrk, ProbEn and ProbTrap to '1' as the Reset value.
ETAP_FASTDATA	5'h0x0E	Selects the Data and Fastdata registers.

20.2 EJTAG TAP Controller

20.2.1 ETAP_ADDRESS COMMAND

ETAP_ADDRESS selects the Address register. The read-only Address register provides the address for a processor access. The value read in the register is valid if a processor access is pending, otherwise the value is undefined.

The two or three Least Significant Bytes (LSBs) of the register are used with the Psz field from the EJTAG Control register to indicate the size and data position of the pending processor access transfer. These bits are not taken directly from the address referenced by the load/store.

20.2.2 ETAP_DATA COMMAND

ETAP_DATA selects the Data register. The read/write Data register is used for op code and data transfers during processor accesses. The value read in the Data register is valid only if a processor access for a write is pending, in which case the Data register holds the store value. The value written to the Data register is only used if a processor access for a pending read is finished afterwards; in which case, the data value written is the value for the fetch or load. This behavior implies that the Data register is not a memory location where a previously written value can be read afterwards.

20.2.3 ETAP_CONTROL COMMAND

ETAP_CONTROL selects the Control register. The EJTAG Control register (ECR) handles processor Reset and soft Reset indication, Debug mode indication, access start, finish and size, and read/write indication. The ECR also provides the following features:

- Controls debug vector location and indication of serviced processor accesses
- Allows a debug interrupt request
- Indicates a processor low-power mode
- Allows implementation-dependent processor and peripheral Resets

20.2.3.1 EJTAG Control Register (ECR)

The EJTAG Control register (see [Register 20-1](#)) is not updated/written in the Update-DR state unless the Reset occurred; that is ROCC (bit 31) is either already '0' or is written to '0' at the same time. This condition ensures proper handling of processor accesses after a Reset.

Reset of the processor can be indicated through the ROCC bit in the TCK domain a number of TCK cycles after it is removed in the processor clock domain in order to allow for proper synchronization between the two clock domains.

Bits that are Read/Write (R/W) in the register return their written value on a subsequent read, unless other behavior is defined.

Internal synchronization ensures that a written value is updated for reading immediately afterwards, even when the TAP controller takes the shortest path from the Update-DR to Capture-DR state.

PIC32

REGISTER 20-1: ECR: EJTAG CONTROL REGISTER

Bit Range	Bit 31/23/15/7	Bit 30/22/14/6	Bit 29/21/13/5	Bit 28/20/12/4	Bit 27/19/11/3	Bit 26/18/10/2	Bit 25/17/9/1	Bit 24/16/8/0
31:24	R/W-0	R-0	R-0	U-0	U-0	U-0	U-0	U-0
	Rocc	Psz<1:0>		—	—	—	—	—
23:16	R-0	R-0	R-0	R/W-0	R-0	R/W-0	U-0	R/W-0
	VPED	Doze	Halt	PerRst	PrnW	PrACC	—	PrRst
15:8	R/W-0	R/W-0	U-0	R/W-0	U-0	U-0	U-0	U-0
	ProbEn	ProbTrap	—	EjtagBrk	—	—	—	—
7:0	U-0	U-0	U-0	U-0	R-0	U-0	U-0	U-0
	—	—	—	—	DM	—	—	—

Legend:

R = Readable bit W = Writable bit U = Unimplemented bit, read as '0'
 -n = Value at POR '1' = Bit is set '0' = Bit is cleared x = Bit is unknown

bit 31-29 See **Note 1**

bit 28-24 **Unimplemented:** Read as '0'

bit 23-19 See **Note 1**

bit 18 **PrACC:** Pending Processor Access and Control bit

This bit indicates a pending processor access and controls finishing of a pending processor access. A write of '0' finishes processor access if pending. A write of '1' is ignored. A successful FASTDATA access will clear this bit.

1 = Pending processor access

0 = No pending preprocessor access

bit 17 **Unimplemented:** Read as '0'

bit 16 See **Note 1**

bit 15 **ProbEn:** Processor Access Service Control bit

This bit controls where the probe handles accesses to the DMSEG segment through servicing of processor accesses.

1 = Probe services processor accesses

0 = Probe does not service processor access

bit 14 **ProbTrap:** Debug Exception Vector Control Location bit

This bit controls the location of the debug exception vector.

1 = 0xFF200200

0 = 0xBFC00480

bit 13 **Unimplemented:** Read as '0'

bit 12 **EjtagBrk:** Debug Interrupt Exception Request bit

This bit requests a debug interrupt exception to the processor when this bit is written as '1'. A write of '0' is ignored.

1 = A debug interrupt exception request is pending

0 = A debug interrupt exception request is not pending

bit 11-4 **Unimplemented:** Read as '0'

bit 3 See **Note 1**

bit 2-0 **Unimplemented:** Read as '0'

Note 1: For descriptions of these bits, please refer to the Imagination Technologies Limited web site. (www.imgtec.com).

20.2.4 ETAP_EJTAGBOOT COMMAND

The `ETAP_EJTAGBOOT` command causes the processor to fetch code from the debug exception vector after a Reset. This allows the programmer to send instructions to the processor to execute, instead of the processor fetching them from the normal Reset vector. The Reset value of the `EjtagBrk`, `ProbTrap`, and `ProbE` bits follows the setting of the internal `EJTAGBOOT` indication.

If the `EJTAGBOOT` instruction has been given, and the internal `EJTAGBOOT` indication is active, then the Reset value of the three bits is set ('1'), otherwise the Reset value is clear ('0').

The results of setting these bits are:

- Setting the `EjtagBrk` causes a Debug interrupt exception to be requested right after the processor Reset from the `EJTAGBOOT` instruction
- The debug handler is executed from the `EJTAG` memory because `ProbTrap` is set to indicate debug vector in `EJTAG` memory at `0xFF200200`
- Service of the processor access is indicated because `ProbEn` is set

With this configuration in place, an interrupt exception will occur and the processor will fetch the handler from the `DMSEG` at `0xFF200200`. Since `ProbEn` is set, the processor will wait for the instruction to be provided by the probe.

20.2.5 ETAP_FASTDATA COMMAND

The `ETAP_FASTDATA` command provides a mechanism for quickly transferring data between the processor and the probe. The width of the `Fastdata` register is one bit. During a fast data access, the `Fastdata` register is written and read (i.e., a bit is shifted in and a bit is shifted out). During a fast data access, the `Fastdata` register value shifted in specifies whether the fast data access should be completed or not. The value shifted out is a flag that indicates whether the fast data access was successful or not (if completion was requested). The `FASTDATA` access is used for efficient block transfers between the `DMSEG` segment (on the probe) and target memory (on the processor). An "upload" is defined as a sequence that the processor loads from target memory and stores to the `DMSEG` segment. A "download" is a sequence of processor loads from the `DMSEG` segment and stores to target memory. The "Fastdata area" specifies the legal range of `DMSEG` segment addresses (`0xFF200000` to `0xFF20000F`) that can be used for uploads and downloads. The `Data` and `Fastdata` registers (selected with the `FASTDATA` instruction) allow efficient completion of pending `Fastdata` area accesses.

During `Fastdata` uploads and downloads, the processor will stall on accesses to the `Fastdata` area. The `PrAcc` (processor access pending bit) will be '1' indicating the probe is required to complete the access. Both upload and download accesses are attempted by shifting in a zero `SPrAcc` value (to request access completion) and shifting out `SPrAcc` to see if the attempt will be successful (i.e., there was an access pending and a legal `Fastdata` area address was used).

Downloads will also shift in the data to be used to satisfy the load from the `DMSEG` segment `Fastdata` area, while uploads will shift out the data being stored to the `DMSEG` segment `Fastdata` area.

As indicated, the following two conditions must be true for the `Fastdata` access to succeed:

- `PrAcc` must be '1' (i.e., there must be a pending processor access)
- The `Fastdata` operation must use a valid `Fastdata` area address in the `DMSEG` segment (`0xFF200000` to `0xFF20000F`)

PIC32

21.0 AC/DC CHARACTERISTICS AND TIMING REQUIREMENTS

TABLE 21-1: AC/DC CHARACTERISTICS AND TIMING REQUIREMENTS

Standard Operating Conditions Operating Temperature: 0°C to +70°C. Programming at +25°C is recommended.						
Param. No.	Symbol	Characteristic	Min.	Max.	Units	Conditions
D111	VDDIO	Supply Voltage During Programming	—	—	V	See Note 1
D112a	VDDCORE	Core Power Supply Voltage During Programming	—	—	V	See Note 1
D112b	VDDR1V8	DDR SDRAM Supply Voltage During Programming	—	—	V	See Note 1
D113	IDDP	Supply Current During Programming	—	—	mA	See Note 1
D114	IPEAK	Instantaneous Peak Current During Start-up	—	—	mA	See Note 1
D115a	IDDCORE	Core Power Supply Current During Programming	—	—	mA	See Note 1
D115b	IDDR1V8P	DDR SDRAM Supply Current During Programming	—	—	mA	See Note 1
D116	VDDVBAT	VBAT Supply Voltage During Programming	—	—	V	See Note 1
D117	IDDVBAT	VBAT Supply Current During Programming	—	—	mA	See Note 1
D031	VIL	Input Low Voltage	—	—	V	See Note 1
D041	VIH	Input High Voltage	—	—	V	See Note 1
D080	VOL	Output Low Voltage	—	—	V	See Note 1
D090	VOH	Output High Voltage	—	—	V	See Note 1
D012	CIO	Capacitive Loading on I/O pin (PGEDx)	—	—	pF	See Note 1
D013	CF	Filter Capacitor Value on VCAP	—	—	μF	See Note 1
P1	TPGC	Serial Clock (PGECx) Period	100	—	ns	—
P1A	TPGCL	Serial Clock (PGECx) Low Time	40	—	ns	—
P1B	TPGCH	Serial Clock (PGECx) High Time	40	—	ns	—
P6	TSET2	VDD ↑ Setup Time to $\overline{\text{MCLR}} \uparrow$	100	—	ns	—
P7	THLD2	Input Data Hold Time from $\overline{\text{MCLR}} \uparrow$	500	—	ns	—
P9a	TDLY4	PE Command Processing Time	40	—	μs	—
P9b	TDLY5	Delay between PGEDx ↓ by the PE to PGEDx Released by the PE	15	—	μs	—
P11	TDLY7	Chip Erase Time	—	—	ms	See Note 1
P12	TDLY8	Page Erase Time	—	—	ms	See Note 1
P13	TDLY9	Row Programming Time	—	—	ms	See Note 1
P14	TR	$\overline{\text{MCLR}}$ Rise Time to Enter ICSP™ mode	—	1.0	μs	—
P15	TVALID	Data Out Valid from PGECx ↑	10	—	ns	—
P16	TDLY8	Delay between Last PGECx ↓ and $\overline{\text{MCLR}} \downarrow$	0	—	s	—
P17	THLD3	$\overline{\text{MCLR}} \downarrow$ to VDD ↓	—	100	ns	—
P18	TKEY1	Delay from First $\overline{\text{MCLR}} \downarrow$ to First PGECx ↑ for Key Sequence on PGEDx	40	—	ns	—
P19	TKEY2	Delay from Last PGECx ↓ for Key Sequence on PGEDx to Second $\overline{\text{MCLR}} \uparrow$	40	—	ns	—
P20	TMCLRH	$\overline{\text{MCLR}}$ High Time	—	500	μs	—

Note 1: Refer to the “**Electrical Characteristics**” chapter in the specific device data sheet for the Minimum and Maximum values for this parameter.

APPENDIX A: PIC32 FLASH MEMORY MAP

FIGURE A-1: FLASH MEMORY MAP

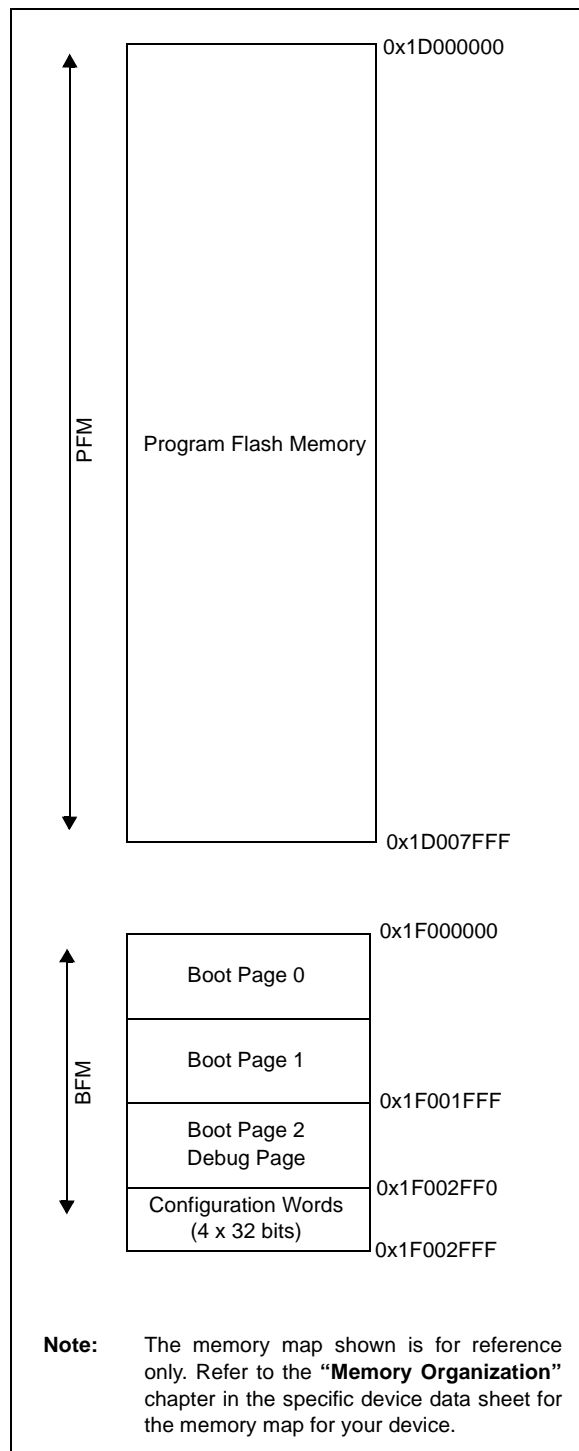

APPENDIX B: HEX FILE FORMAT

Flash programmers process the standard hexadecimal (hex) format used by the Microchip development tools. The format supported is the Intel® HEX32 Format (INHX32). Refer to the **Section 1.75 "Hex file Formats"** in the "MPASM™ Assembler, MPLINK™ Object Linker, MPLIB™ Object Librarian User's Guide" (DS33014) for more information about hex file formats.

The basic format of the hex file is:

```
:BBAAAATTHHHH...HHHCC
```

Each data record begins with a 9-character prefix and always ends with a 2-character checksum. All records begin with ':', regardless of the format. The individual elements are described below.

- **BB** – is a two-digit hexadecimal byte count representing the number of data bytes that appear on the line. Divide this number by two to get the number of words per line.
- **AAAA** – is a four-digit hexadecimal address representing the starting address of the data record. Format is high byte first followed by low byte.
- **TT** – is a two-digit record type that will be '00' for data records, '01' for end-of-file records and '04' for extended-address record.
- **HHHH** – is a four-digit hexadecimal data word. Format is low byte followed by high byte. There will be $BB/2$ data words following **TT**.
- **CC** – is a two-digit hexadecimal checksum that is the 2's complement of the sum of all the preceding bytes in the line record.

Because the Intel hex file format is byte-oriented, and the 16-bit program counter is not, program memory sections require special treatment. Each 24-bit program word is extended to 32 bits by inserting a so-called "phantom byte". Each program memory address is multiplied by 2 to yield a byte address.

As an example, a section that is located at 0x100 in program memory will be represented in the hex file as 0x200.

The hex file will be produced with the following contents:

```
:020000040000fa
:040200003322110096
:00000001FF
```

The data record (second line) has a load address of 0200, while the source code specified address is 0x100. The data is represented in "little-endian" format, that is the Least Significant Byte appears first and the phantom byte appears last, before the checksum.

PIC32

APPENDIX C: DEVICE IDS

TABLE C-1: PIC32MX320/340/360/440/460 FAMILY DEVICE IDS

Part Number	Device ID (See Note 1)
PIC32MX360F512L	0x0938053
PIC32MX360F256L	0x0934053
PIC32MX340F128L	0x092D053
PIC32MX320F128L	0x092A053
PIC32MX340F512H	0x0916053
PIC32MX340F256H	0x0912053
PIC32MX340F128H	0x090D053
PIC32MX320F128H	0x090A053
PIC32MX320F064H	0x0906053
PIC32MX320F032H	0x0902053
PIC32MX460F512L	0x0978053
PIC32MX460F256L	0x0974053
PIC32MX440F128L	0x096D053
PIC32MX440F256H	0x0952053
PIC32MX440F512H	0x0956053
PIC32MX440F128H	0x094D053
PIC32MX420F032H	0x0942053

TABLE C-2: PIC32MX575/675/695/775/795 FAMILY DEVICE IDS

Part Number	Device ID (See Note 1)
PIC32MX575F256H	0x04317053
PIC32MX675F256H	0x0430B053
PIC32MX775F256H	0x04303053
PIC32MX575F512H	0x04309053
PIC32MX675F512H	0x0430C053
PIC32MX695F512H	0x04325053
PIC32MX775F512H	0x0430D053
PIC32MX795F512H	0x0430E053
PIC32MX575F256L	0x04333053
PIC32MX675F256L	0x04305053
PIC32MX775F256L	0x04312053
PIC32MX575F512L	0x0430F053
PIC32MX675F512L	0x04311053
PIC32MX695F512L	0x04341053
PIC32MX775F512L	0x04307053
PIC32MX795F512L	0x04307053

TABLE C-3: PIC32MX534/564/664/764 FAMILY DEVICE IDS

Part Number	Device ID (See Note 1)
PIC32MX534F064H	0x04400053
PIC32MX564F064H	0x04401053
PIC32MX564F128H	0x04403053
PIC32MX664F064H	0x04405053
PIC32MX664F128H	0x04407053
PIC32MX764F128H	0x0440B053
PIC32MX534F064L	0x0440C053
PIC32MX564F064L	0x0440D053
PIC32MX564F128L	0x0440F053
PIC32MX664F064L	0x04411053
PIC32MX664F128L	0x04413053
PIC32MX764F128L	0x04417053

TABLE C-4: PIC32MX1XX/2XX 28/36/44-PIN FAMILY DEVICE IDS

Part Number	Device ID (See Note 1)
PIC32MX110F016B	0x04A07053
PIC32MX110F016C	0x04A09053
PIC32MX110F016D	0x04A0B053
PIC32MX210F016B	0x04A01053
PIC32MX210F016C	0x04A03053
PIC32MX210F016D	0x04A05053
PIC32MX120F032B	0x04A06053
PIC32MX120F032C	0x04A08053
PIC32MX120F032D	0x04A0A053
PIC32MX220F032B	0x04A00053
PIC32MX220F032C	0x04A02053
PIC32MX220F032D	0x04A04053
PIC32MX130F064B	0x04D07053
PIC32MX130F064C	0x04D09053
PIC32MX130F064D	0x04D0B053
PIC32MX230F064B	0x04D01053
PIC32MX230F064C	0x04D03053
PIC32MX230F064D	0x04D05053
PIC32MX150F128B	0x04D06053
PIC32MX150F128C	0x04D08053
PIC32MX150F128D	0x04D0A053
PIC32MX250F128B	0x04D00053
PIC32MX250F128C	0x04D02053
PIC32MX250F128D	0x04D04053
PIC32MX170F256B	0x06610053
PIC32MX170F256D	0x0661A053
PIC32MX270F256B	0x06600053
PIC32MX270F256D	0x0660A053
PIC32MX270F256DB	0x0660C053
PIC32MX130F256B	0x06703053
PIC32MX130F256D	0x06705053
PIC32MX230F256B	0x06700053
PIC32MX230F256D	0x06702053

TABLE C-5: PIC32MX330/350/370/430/450/470 FAMILY DEVICE IDS

Part Number	Device ID (See Note 1)
PIC32MX330F064H	0x05600053
PIC32MX330F064L	0x05601053
PIC32MX350F256H	0x05704053
PIC32MX350F256L	0x05705053
PIC32MX430F064H	0x05602053
PIC32MX430F064L	0x05603053
PIC32MX450F256H	0x05706053
PIC32MX450F256L	0x05707053
PIC32MX350F128H	0x0570C053
PIC32MX350F128L	0x0570D053
PIC32MX450F128H	0x0570E053
PIC32MX450F128L	0x0570F053
PIC32MX370F512H	0x05808053
PIC32MX370F512L	0x05809053
PIC32MX470F512H	0x0580A053
PIC32MX470F512L	0x0580B053
PIC32MX450F256HB	0x05710053
PIC32MX470F512LB	0x05811053

TABLE C-7: PIC32MX1XX/2XX/5XX 64/100-PIN FAMILY DEVICE IDS

Part Number	Device ID (See Note 1)
PIC32MX150F256H	0x06A10053
PIC32MX150F256L	0x06A11053
PIC32MX170F512H	0x06A30053
PIC32MX170F512L	0x06A31053
PIC32MX250F256H	0x06A12053
PIC32MX250F256L	0x06A13053
PIC32MX270F512H	0x06A32053
PIC32MX270F512L	0x06A33053
PIC32MX550F256H	0x06A14053
PIC32MX550F256L	0x06A15053
PIC32MX570F512H	0x06A34053
PIC32MX570F512L	0x06A35053
PIC32MX120F064H	0x06A50053
PIC32MX130F128H	0x06A00053
PIC32MX130F128L	0x06A01053
PIC32MX230F128H	0x06A02053
PIC32MX230F128L	0x06A03053
PIC32MX530F128H	0x06A04053
PIC32MX530F128L	0x06A05053

TABLE C-6: PIC32MZ EMBEDDED CONNECTIVITY (EC) FAMILY DEVICE IDS

Part Number	Device ID (See Note 1)
PIC32MZ1024ECG064	0x05103053
PIC32MZ1024ECH064	0x05108053
PIC32MZ1024ECM064	0x05130053
PIC32MZ2048ECG064	0x05104053
PIC32MZ2048ECH064	0x05109053
PIC32MZ2048ECM064	0x05131053
PIC32MZ1024ECG100	0x0510D053
PIC32MZ1024ECH100	0x05112053
PIC32MZ1024ECM100	0x0513A053
PIC32MZ2048ECG100	0x0510E053
PIC32MZ2048ECH100	0x05113053
PIC32MZ2048ECM100	0x0513B053
PIC32MZ1024ECG124	0x05117053
PIC32MZ1024ECH124	0x0511C053
PIC32MZ1024ECM124	0x05144053
PIC32MZ2048ECG124	0x05118053
PIC32MZ2048ECH124	0x0511D053
PIC32MZ2048ECM124	0x05145053
PIC32MZ1024ECG144	0x05121053
PIC32MZ1024ECH144	0x05126053
PIC32MZ1024ECM144	0x0514E053
PIC32MZ2048ECG144	0x05122053
PIC32MZ2048ECH144	0x05127053
PIC32MZ2048ECM144	0x0514F053

PIC32

TABLE C-8: PIC32MZ EMBEDDED CONNECTIVITY WITH FPU (EF) FAMILY DEVICE IDS

Part Number	Device ID (See Note 1)
PIC32MZ0512EFE064	0x07201053
PIC32MZ0512EFF064	0x07206053
PIC32MZ0512EFK064	0x0722E053
PIC32MZ1024EFE064	0x07202053
PIC32MZ1024EFF064	0x07207053
PIC32MZ1024EFK064	0x0722F053
PIC32MZ1024EFG064	0x07203053
PIC32MZ1024EFH064	0x07208053
PIC32MZ1024EFM064	0x07230053
PIC32MZ2048EFG064	0x07204053
PIC32MZ2048EFH064	0x07209053
PIC32MZ2048EFM064	0x07231053
PIC32MZ0512EFE100	0x0720B053
PIC32MZ0512EFF100	0x07210053
PIC32MZ0512EFK100	0x07238053
PIC32MZ1024EFE100	0x0720C053
PIC32MZ1024EFF100	0x07211053
PIC32MZ1024EFK100	0x07239053
PIC32MZ1024EFG100	0x0720D053
PIC32MZ1024EFH100	0x07212053
PIC32MZ1024EFM100	0x0723A053
PIC32MZ2048EFG100	0x0720E053
PIC32MZ2048EFH100	0x07213053
PIC32MZ2048EFM100	0x0723B053
PIC32MZ0512EFE124	0x07215053
PIC32MZ0512EFF124	0x0721A053
PIC32MZ0512EFK124	0x07242053
PIC32MZ1024EFE124	0x07216053
PIC32MZ1024EFF124	0x0721B053
PIC32MZ1024EFK124	0x07243053
PIC32MZ1024EFG124	0x07217053
PIC32MZ1024EFH124	0x0721C053
PIC32MZ1024EFM124	0x07244053
PIC32MZ2048EFG124	0x07218053
PIC32MZ2048EFH124	0x0721D053
PIC32MZ2048EFM124	0x07245053
PIC32MZ0512EFE144	0x0721F053
PIC32MZ0512EFF144	0x07224053
PIC32MZ0512EFK144	0x0724C053
PIC32MZ1024EFE144	0x07220053
PIC32MZ1024EFF144	0x07225053
PIC32MZ1024EFK144	0x0724D053
PIC32MZ1024EFG144	0x07221053
PIC32MZ1024EFH144	0x07226053
PIC32MZ1024EFM144	0x0724E053
PIC32MZ2048EFG144	0x07222053
PIC32MZ2048EFH144	0x07227053
PIC32MZ2048EFM144	0x0724F053

TABLE C-9: PIC32MZ GRAPHICS (DA) FAMILY DEVICE IDS

Part Number	Device ID (See Note 1)
PIC32MZ1025DAA169	0x05F0C053
PIC32MZ1025DAB169	0x05F0D053
PIC32MZ1064DAA169	0x05F0F053
PIC32MZ1064DAB169	0x05F10053
PIC32MZ2025DAA169	0x05F15053
PIC32MZ2025DAB169	0x05F16053
PIC32MZ2064DAA169	0x05F18053
PIC32MZ2064DAB169	0x05F19053
PIC32MZ1025DAG169	0x05F42053
PIC32MZ1025DAH169	0x05F43053
PIC32MZ1064DAG169	0x05F45053
PIC32MZ1064DAH169	0x05F46053
PIC32MZ2025DAG169	0x05F4B053
PIC32MZ2025DAH169	0x05F4C053
PIC32MZ2064DAG169	0x05F4E053
PIC32MZ2064DAH169	0x05F4F053
PIC32MZ1025DAA176	0x05F78053
PIC32MZ1025DAB176	0x05F79053
PIC32MZ1064DAA176	0x05F7B053
PIC32MZ1064DAB176	0x05F7C053
PIC32MZ2025DAA176	0x05F81053
PIC32MZ2025DAB176	0x05F82053
PIC32MZ2064DAA176	0x05F84053
PIC32MZ2064DAB176	0x05F85053
PIC32MZ1025DAG176	0x05FAE053
PIC32MZ1025DAH176	0x05FAF053
PIC32MZ1064DAG176	0x05FB1053
PIC32MZ1064DAH176	0x05FB2053
PIC32MZ2025DAG176	0x05FB7053
PIC32MZ2025DAH176	0x05FB8053
PIC32MZ2064DAG176	0x05FBA053
PIC32MZ2064DAH176	0x05FBB053
PIC32MZ1025DAA288	0x05F5D053
PIC32MZ1025DAB288	0x05F5E053
PIC32MZ1064DAA288	0x05F60053
PIC32MZ1064DAB288	0x05F61053
PIC32MZ2025DAA288	0x05F66053
PIC32MZ2025DAB288	0x05F67053
PIC32MZ2064DAA288	0x05F69053
PIC32MZ2064DAB288	0x05F6A053
PIC32MZ1025DAK169	0x08A0C053
PIC32MZ1025DAL169	0x08A0D053
PIC32MZ1064DAK169	0x08A0F053
PIC32MZ1064DAL169	0x08A10053
PIC32MZ2025DAK169	0x08A15053
PIC32MZ2025DAL169	0x08A16053
PIC32MZ2064DAK169	0x08A18053

**TABLE C-9: PIC32MZ GRAPHICS (DA)
FAMILY DEVICE IDS
(CONTINUED) (CONTINUED)
(CONTINUED)**

Part Number	Device ID (See Note 1)
PIC32MZ2064DAL169	0x08A19053
PIC32MZ1025DAR169	0x08A42053
PIC32MZ1025DAS169	0x08A43053
PIC32MZ1064DAR169	0x08A45053
PIC32MZ1064DAS169	0x08A46053
PIC32MZ2025DAR169	0x08A4B053
PIC32MZ2025DAS169	0x08A4C053
PIC32MZ2064DAR169	0x08A4E053
PIC32MZ2064DAS169	0x08A4F053
PIC32MZ1025DAK176	0x08A78053
PIC32MZ1025DAL176	0x08A79053
PIC32MZ1064DAK176	0x08A7B053
PIC32MZ1064DAL176	0x08A7C053
PIC32MZ2025DAK176	0x08A81053
PIC32MZ2025DAL176	0x08A82053
PIC32MZ2064DAK176	0x08A84053
PIC32MZ2064DAL176	0x08A85053
PIC32MZ1025DAR176	0x08AAE053
PIC32MZ1025DAS176	0x08AAF053
PIC32MZ1064DAR176	0x08AB1053
PIC32MZ1064DAS176	0x08AB2053
PIC32MZ2025DAR176	0x08AB7053
PIC32MZ2025DAS176	0x08AB8053
PIC32MZ2064DAR176	0x08ABA053
PIC32MZ2064DAS176	0x08ABB053

PIC32

TABLE C-10: PIC32MX1XX/2XX 28/44-PIN XLP FAMILY DEVICE IDS

Part Number	Device ID (See Note 1)
PIC32MX154F128B	0x07800053
PIC32MX154F128D	0x07804053
PIC32MX155F128B	0x07808053
PIC32MX155F128D	0x0780C053
PIC32MX174F256B	0x07801053
PIC32MX174F256D	0x07805053
PIC32MX175F256B	0x07809053
PIC32MX175F256D	0x0780D053
PIC32MX254F128B	0x07802053
PIC32MX254F128D	0x07806053
PIC32MX255F128B	0x0780A053
PIC32MX255F128D	0x0780E053
PIC32MX274F256B	0x07803053
PIC32MX274F256D	0x07807053
PIC32MX275F256B	0x0780B053
PIC32MX275F256D	0x0780F053

TABLE C-11: PIC32MK GENERAL PURPOSE AND MOTOR CONTROL (GP/MC) FAMILY DEVICE IDS

Part Number	Device ID (See Note 1)
PIC32MK1024MCF100	0x06201053
PIC32MK1024MCF064	0x06202053
PIC32MK0512MCF100	0x06204053
PIC32MK0512MCF064	0x06205053
PIC32MK1024GPE100	0x06207053
PIC32MK1024GPE064	0x06208053
PIC32MK0512GPE100	0x0620A053
PIC32MK0512GPE064	0x0620B053
PIC32MK1024GPD100	0x0620D053
PIC32MK1024GPD064	0x0620E053
PIC32MK0512GPD100	0x06210053
PIC32MK0512GPD064	0x06211053

TABLE C-12: PIC32MK GENERAL PURPOSE AND MOTOR CONTROL (GP/MC) with ECC FLASH FAMILY DEVICE IDS

Part Number	Device ID (See Note 1)
PIC32MK1024MCM100	0x08B01053
PIC32MK1024MCM064	0x08B02053
PIC32MK0512MCM100	0x08B04053
PIC32MK0512MCM064	0x08B05053
PIC32MK1024GPL100	0x08B07053
PIC32MK1024GPL064	0x08B08053
PIC32MK0512GPL100	0x08B0A053
PIC32MK0512GPL064	0x08B0B053
PIC32MK1024GPK100	0x08B0D053
PIC32MK1024GPK064	0x08B0E053
PIC32MK0512GPK100	0x08B10053
PIC32MK0512GPK064	0x08B11053
PIC32MK0512MCJ064	0x06300053
PIC32MK0512MCJ048	0x06301053
PIC32MK0512MCJ040	0x06302053
PIC32MK0256MCJ064	0x06304053
PIC32MK0256MCJ048	0x06305053
PIC32MK0256MCJ040	0x06306053
PIC32MK0512GPH064	0x06308053
PIC32MK0512GPH048	0x06309053
PIC32MK0512GPH040	0x0630A053
PIC32MK0256GPH064	0x0630C053
PIC32MK0256GPH048	0x0630D053
PIC32MK0256GPH040	0x0630E053
PIC32MK0512GPG064	0x06318053
PIC32MK0512GPG048	0x06319053
PIC32MK0512GPG040	0x0631A053
PIC32MK0256GPG064	0x0631C053
PIC32MK0256GPG048	0x0631D053
PIC32MK0256GPG040	0x0631E053

Note 1: The first 4 bits of 32-bit device ID indicates silicon revision.

APPENDIX D: REVISION HISTORY

Revision A (August 2007)

This is the initial released version of the document.

Revision B (February 2008)

Update records for this revision are not available.

Revision C (April 2008)

Update records for this revision are not available.

Revision D (May 2008)

Update records for this revision are not available.

Revision E (July 2009)

This version of the document includes the following additions and updates:

- Minor changes to style and formatting have been incorporated throughout the document
- Added the following devices:
 - PIC32MX565F256H
 - PIC32MX575F512H
 - PIC32MX675F512H
 - PIC32MX795F512H
 - PIC32MX575F512L
 - PIC32MX675F512L
 - PIC32MX795F512L
- Updated $\overline{\text{MCLR}}$ pulse line to show active-high (P20) in Figure 7-1
- Updated Step 7 of Table 11-1 to clarify repeat of the *last* instruction in the step
- The following instructions in Table 13-1 were updated:
 - Seventh, ninth and eleventh instructions in Step 1
 - All instructions in Step 2
 - First instruction in Step 3
 - Third instruction in Step 4
- Added the following devices to Table 17-1:
 - PIC32MX565F256H
 - PIC32MX575F512H
 - PIC32MX575F512L
 - PIC32MX675F512H
 - PIC32MX675F512L
 - PIC32MX795F512H
 - PIC32MX795F512L
- Updated address values in Table 17-2

Revision E (July 2009) (Continued)

- Added the following devices to Table 17-5:
 - PIC32MX565F256H
 - PIC32MX575F512H
 - PIC32MX675F512H
 - PIC32MX795F512H
 - PIC32MX575F512L
 - PIC32MX675F512L
 - PIC32MX795F512L
- Added Notes 1-3 and the following bits to the DEVCFG - Device Configuration Word Summary and the DEVCFG3: Device Configuration Word 3 (see Table 18-1 and Register):
 - FVBUSIO
 - FUSBIDIO
 - FCANIO
 - FETHIO
 - FMIEN
 - FPBDIV<1:0>
 - FJTAGEN
- Updated the DEVID Summary (see Table 18-1)
- Updated ICESSEL bit description and added the FJTAGEN bit in DEVCFG0: Device Configuration Word 0 (see Register 16-1)
- Updated DEVID: Device and Revision ID register
- Added Device IDs and Revision table (Table 18-4)
- Added $\overline{\text{MCLR}}$ High Time (parameter P20) to Table 20-1
- Added **Appendix B: “Hex File Format”** and **Appendix D: “Revision History”**

Revision F (April 2010)

This version of the document includes the following additions and updates:

- The following global bit name changes were made:
 - NVMWR renamed as WR
 - NVMWREN renamed as WREN
 - NVMERR renamed as WRERR
 - FVBUSIO renamed as FVBUSONIO
 - FUPPLEN renamed as UPLEN
 - FUPLLIDIV renamed as UPLLIDIV
 - POSCMD renamed as POSCMOD
- Updated the PIC32MX family data sheet references in the fourth paragraph of **Section 2.0 “Programming Overview”**
- Updated the note in **Section 5.2.2 “2-Phase ICSP”**
- Updated the Initiate Flash Row Write Op Codes and instructions (see steps 4, 5 and 6 in Table 13-1)

PIC32

Revision F (April 2010) (Continued)

- Added the following devices:
 - PIC32MX534F064H
 - PIC32MX534F064L
 - PIC32MX564F064H
 - PIC32MX564F064L
 - PIC32MX564F128H
 - PIC32MX564F128L
 - PIC32MX575F256L
 - PIC32MX664F064H
 - PIC32MX664F064L
 - PIC32MX664F128H
 - PIC32MX664F128L
 - PIC32MX675F256H
 - PIC32MX675F256L
 - PIC32MX695F512H
 - PIC32MX605F512L
 - PIC32MX764F128H
 - PIC32MX764F128L
 - PIC32MX775F256H
 - PIC32MX775F256L
 - PIC32MX775F512H
 - PIC32MX775F512L

Revision G (August 2010)

This revision of the document includes the following updates:

- Updated Step 3 in Table 11-1: Download the PE
- Minor corrections to formatting and text have been incorporated throughout the document

Revision H (April 2011)

This version of the document includes the following additions and updates:

- Updates to formatting and minor typographical changes have been incorporated throughout the document
- The following devices were added:
 - PIC32MX110F016B
 - PIC32MX110F016C
 - PIC32MX110F016D
 - PIC32MX120F032B
 - PIC32MX120F032C
 - PIC32MX120F032D
 - PIC32MX210F016B
 - PIC32MX210F016C
 - PIC32MX210F016D
 - PIC32MX220F032B
 - PIC32MX220F032C
 - PIC32MX220F032D
- The following rows were added to Table 17-1:
 - PIC32MX1X0
 - PIC32MX2X0
- Added a new sub section **Section 17.4.6 “Checksum Values While Device Is Code-Protected”**

- Removed Register 18-1 through Register 18-5.
- Removed Table 17-2
- Removed Section 17.5 “Checksum for PIC32 Devices” and its sub sections
- The Flash Program Memory Write-Protect Ranges table was removed (formerly Table 18-4)
- Added DEVCFG Locations for PIC32MX1X0 and PIC32MX20X Devices Only (see Table 18-3)
- In **Section 18.0 “Configuration Memory and Device ID”**, removed Table 18-1 and updated Table 18-2: DEVID Summary as Table 18-1
- Added the NVMERR bit to the MCHP Status Value table (see Table 19-3)
- The following Silicon Revision and Revision ID are added to Table 18-4:
 - 0x5 - B6 Revision
 - 0x1 - A1 Revision
- Added a note to the Flash Memory Map (see Figure A-1)
- Added **Appendix C: “Flash Program Memory Data Sheet Clarification”**

Revision J (August 2011)

Note: The revision history in this document intentionally skips from Revision H to Revision J to avoid confusing the uppercase letter “I” (EY) with the lowercase letter “l” (EL).

This revision includes the following updates:

- All occurrences of V_{CORE}/V_{CAP} have been changed to V_{CAP}
- Updated the fourth paragraph of **Section 2.0 “Programming Overview”**
- Removed the column, Programmer Pin Name, from the 2-Wire Interface Pins table and updated the Pin Type for \overline{MCLR} (see Table 4-2)
- Added the following new devices to the Code Memory Size table (see Table 5-1) and the Device IDs and Revision table (see Table 18-4):
 - PIC32MX130F064B
 - PIC32MX130F064C
 - PIC32MX130F064D
 - PIC32MX150F128B
 - PIC32MX150F128C
 - PIC32MX150F128D
 - PIC32MX230F064B
 - PIC32MX230F064C
 - PIC32MX230F064D
 - PIC32MX250F128B
 - PIC32MX250F128C
 - PIC32MX250F128D
- Added Row Size and Page Size columns to the Code Memory Size table (see Table 5-1)

Revision J (August 2011) (Continued)

- Updated the PGCx signal in Entering Enhanced ICSP Mode (see Figure 7-1)
- Updated the Erase Device block diagram (see Figure 9-1)
- Added a new step 4 to the process to erase a target device in **Section 9.0 “Erasing the Device”**
- Updated the $\overline{\text{MCLR}}$ signal in 2-Wire Exit Test Mode (see Figure 15-2)
- Updated the PE Command Set with the following commands and modified Note 2 (see Table 16-2):
 - PROGRAM_CLUSTER
 - GET_DEVICEID
 - CHANGE_CFG
- Added a second note to **Section 16.2.11 “GET_CRC Command”**
- Updated the Address and Length descriptions in the PROGRAM_CLUSTER Format (see Table 16-13)
- Added a note after the CHANGE_CFG Response (see Figure 16-27)
- Updated the DEVCFG0 and DEVCFG1 values for All PIC32MX1XX and All PIC32MX2XX devices in Table 17-1
- The following changes were made to the AC/DC Characteristics and Timing Requirements (Table 20-1):
 - Updated the Min. value for parameter D111 (VDD)
 - Added parameter D114 (IPEAK)
 - Removed parameters P2, P3, P4, P4A, P5, P8 and P10
- Removed Appendix C: “Flash Program Memory Data Sheet Clarification”
- Minor updates to text and formatting were incorporated throughout the document

Revision K (July 2012)

This revision includes the following updates:

- All occurrences of PGC and PGD were changed to: PGEC and PGED, respectively
- Updated **Section 1.0 “Device Overview”** with a list of all major topics in this document
- Added **Section 2.3 “Data Sizes”**
- Updated **Section 4.0 “Connecting to the Device”**
- Added Note 2 to Connections for the On-chip Regulator (see Figure 4-2)
- Added Note 2 to the 4-wire and 2-wire Interface Pins tables (see Table 4-1 and Table 4-2)
- Updated **Section 7.0 “Entering 2-Wire Enhanced ICSP Mode”**
- Updated Entering Serial Execution Mode (see Figure 10-1)
- Updated step 11 in **Section 10.2 “2-wire Interface”**

- Updated **Section 12.2 “With the PE”**
- Updated Step 3 in Initiate Flash Row Write Op Codes (see Table 13-1)
- Updated Step 1 in Verify Device op Codes (see Table 14-1)
- Updated the interval in **Section 15.1 “4-wire Interface”** and **Section 15.2 “2-wire Interface”**
- Added a note regarding the PE location in **Section 16.0 “The Programming Executive”**
- Added references to the Operand field throughout **Section 16.2 “The PE Command Set”**
- Updated the PROGRAM Command Algorithm (see Figure 16-9)
- Updated the mask values for All PIC32MX1XX and PIC32MX2XX devices, and DEVCFG3 for all devices (see Table 17-1)
- Updated the DCR value (see **Section 17.4.3 “Calculating for “DCR” in the Checksum Formula”** and Table 17-2)
- Updated the Checksum Calculation Process (see Example 17-1)
- Added these new devices to the Code Memory Size table (see Table 5-1) and the Device IDs and Revision table (see Table 18-4):

- PIC32MX420F032H	- PIC32MX450F128L
- PIC32MX330F064H	- PIC32MX440F256H
- PIC32MX330F064L	- PIC32MX450F256H
- PIC32MX430F064H	- PIC32MX450F256L
- PIC32MX430F064L	- PIC32MX460F256L
- PIC32MX340F128H	- PIC32MX340F512H
- PIC32MX340F128L	- PIC32MX360F512H
- PIC32MX350F128H	- PIC32MX370F512H
- PIC32MX350F128L	- PIC32MX370F512L
- PIC32MX350F256H	- PIC32MX440F512H
- PIC32MX350F256L	- PIC32MX460F512L
- PIC32MX440F128H	- PIC32MX470F512H
- PIC32MX440F128L	- PIC32MX470F512L
- PIC32MX450F128H	
- Added a Note to **Section 18.2 “Device Code Protection bit (CP)”**
- Added the EJTAG Control Register (see Register 19-1)
- Updated **Section 19.2.4 “ETAP_EJTAGBOOT Command”**
- AC/DC Characteristics and Timing Requirements updates (see Table 20-1):
 - Removed parameter D112
 - Replaced Notes 1 and 2 with a new Note 1
 - Updated parameters D111, D113, D114, D031, D041, D080, D090, D012, D013, P11, P12, and P13
- Minor updates to text and formatting were incorporated through the document

PIC32

Revision L (January 2013)

This revision includes the following updates:

- The following sections were added or updated:
 - **Section 2.1 “Devices with Dual Flash Panel and Dual Boot Regions”** (new)
 - **Section 4.3 “Power Requirements”**
 - **Section 13.0 “Initiating a Flash Row Write”**
 - **Section 16.1.1 “2-wire ICSP EJTAG RATE”**
- Updated the Device Configuration Register Mask Values (see Table 17-1)
- The following devices were added to the Code Memory Size table and the Device IDs and Revision table (see Table 5-1 and Table 18-4):

- PIC32MZ0256ECE064	- PIC32MZ1024ECF064
- PIC32MZ0256ECE100	- PIC32MZ1024ECF100
- PIC32MZ0256ECE124	- PIC32MZ1024ECF124
- PIC32MZ0256ECE144	- PIC32MZ1024ECF144
- PIC32MZ0256ECF064	- PIC32MZ1024ECG064
- PIC32MZ0256ECF100	- PIC32MZ1024ECG100
- PIC32MZ0256ECF124	- PIC32MZ1024ECG124
- PIC32MZ0256ECF144	- PIC32MZ1024ECG144
- PIC32MZ0512ECE064	- PIC32MZ1024ECH064
- PIC32MZ0512ECE100	- PIC32MZ1024ECH100
- PIC32MZ0512ECE124	- PIC32MZ1024ECH124
- PIC32MZ0512ECE144	- PIC32MZ1024ECH144
- PIC32MZ0512ECF064	- PIC32MZ2048ECG064
- PIC32MZ0512ECF100	- PIC32MZ2048ECG100
- PIC32MZ0512ECF124	- PIC32MZ2048ECG124
- PIC32MZ0512ECF144	- PIC32MZ2048ECG144
- PIC32MZ1024ECE064	- PIC32MZ2048ECH064
- PIC32MZ1024ECE100	- PIC32MZ2048ECH100
- PIC32MZ1024ECE124	- PIC32MZ2048ECH124
- PIC32MZ1024ECE144	- PIC32MZ2048ECH144
- Note 3 and Note 4 and the `GET_CHECKSUM` and `QUAD_WORD_PRGM` commands were added to the PE Command Set (see Table 16-2)
- Added **Section 16.2.15 “GET_CHECKSUM Command”**
- Added **Section 16.2.16 “QUAD_WORD_PRO-GRAM Command”**
- Updated all addresses in DEVCFG Locations (see Table 18-1 and Table 18-2)
- Added Configuration Word Locations for PIC32MZ EC Family Devices (see Table 18-3)
- Updated **Section 18.2 “Device Code Protection bit (CP)”**
- Updated **Section 18.3 “Program Write Protection bits (PWP)”**
- All references to Test mode were updated to programming mode throughout the document
- Minor updates to text and formatting were incorporated through the document

Revision M (September 2013)

This revision includes the following updates:

- All references to MIPS Technologies Inc. and www.mips.com were updated to Imagination Technologies Limited and www.imgtec.com, respectively
- Updated **Section 2.0 “Programming Overview”**
- Updated the last paragraph in **Section 5.1.6 “Flash Memory”**
- Updated Code Memory Sizes and added Note 3 (see Table 5-1)
- Updated the Erase Device flow diagram (see Figure 9-1)
- Updated Steps 1, 2, 3, and 5 in Table 11-1
- Added a new paragraph in **Section 13.2 “Without the PE”**
- Updated Step 2, 3, and 5 in Table 13-1
- Updated the Op code description in Table 16-17
- Updated Device Configuration Mask Values (see Table 17-1)
- Removed the first sentence in the fourth paragraph of **Section 17.3 “Algorithm”**
- Updated Device IDs and Revision (see Table 18-4)

Revision N (April 2014)

This revision includes the following updates:

- Note 2 was updated in **TABLE 4-1: “4-wire Interface Pins”**
- Note 2 was updated in **TABLE 4-2: “2-wire Interface Pins”**
- The Delay value in Step 5 of **Section 9.0 “Erasing the Device”** was updated
- The Revision ID and Silicon Revision column was updated and the following devices were added to the Device IDs and Revision table (see Table 18-4):

- PIC32MX170F256B	- PIC32MX350F256H
- PIC32MX170F256D	- PIC32MX350F256L
- PIC32MX270F256B	- PIC32MX430F064H
- PIC32MX270F256D	- PIC32MX430F064L
- PIC32MX330F064H	- PIC32MX450F128H
- PIC32MX330F064L	- PIC32MX450F128L
- PIC32MX350F128H	- PIC32MX450F256H
- PIC32MX350F128L	- PIC32MX450F256L

Revision P (October 2014)

Note: The revision history in this document intentionally skips from Revision N to Revision P to avoid confusing the uppercase letter “O” with the number zero “0”.

The following updates were implemented:

- **TABLE 5-1: “Code Memory Size”** was updated to include PIC32MK device information
- **TABLE 18-1: “Device Configuration Register Mask Values of Currently Supported PIC32MX, PIC32MZ, and PIC32MK Devices”** was updated to include PIC32MK device information
- The original table, Table 18-4: Device IDs and Revision was removed as this information is readily available in the current Family Silicon Errata
- **TABLE 19-4: “Configuration Word Locations for PIC32MK family Devices”** was added

Revision Q (July 2015)

This revision includes the following updates:

- **Section 14.0 “Initiating a Flash Row Write”** was added
- **TABLE 18-1: “Device Configuration Register Mask Values of Currently Supported PIC32MX, PIC32MZ, and PIC32MK Devices”** was updated to include DEVCFG4
- **EQUATION 18-1: “Checksum Formula”** was updated
- **TABLE 19-3: “Configuration Word Locations for PIC32MZ family Devices”** was updated to include DEVCFG4
- Minor updates to text and formatting were incorporated throughout the document

Revision R (April 2016)

This revision includes the following updates:

- **FIGURE 4-1: “Programming Interfaces”** was updated
- **TABLE 4-1: “4-wire Interface Pins”** was updated
- **TABLE 4-2: “2-wire Interface Pins”** was updated
- **FIGURE 4-4: “PIC32MZ EC/EF Power Connections”** was updated
- **FIGURE 4-5: “PIC32MZ DA Power Connections”** was updated
- **TABLE 5-1: “Code Memory Size”** was updated
- **FIGURE 5-2: “Basic PIC32 Programming Interface Block Diagram”** was updated
- **FIGURE 16-1: “4-wire Exit Programming Mode”** was updated
- **FIGURE 16-2: “2-wire Exit Programming Mode”** was updated

- Parameters D112 (VDD1V8) and D115 (IDD1V8P) were added to **TABLE 21-1: “AC/DC Characteristics and Timing Requirements”**
- **Section 4.3 “PIC32MX Power Requirements”** was updated
- **Section 4.4 “PIC32MX With VBAT Pin Power Requirements”** was added
- **Section 4.5 “PIC32MZ EC and PIC32MZ EF Power Requirements”** was added
- **Section 4.6 “PIC32MZ DA Power Requirements”** was added
- **Section 4.7 “PIC32MK Power Requirements”** was added
- **Section 5.3.3 “Synchronization”** was added
- **Section 6.7 “Synchronize Pseudo Operation”** was added
- **Section 8.1 “4-wire Interface”** was updated
- **Section 8.2 “2-wire Interface”** was updated
- **TABLE 13-1: “Page Erase Op Codes”** was updated
- **TABLE 18-1: “Device Configuration Register Mask Values of Currently Supported PIC32MX, PIC32MZ, and PIC32MK Devices”** was updated
- Note 1 in the Checksum Formula was updated (see Equation 18-1)

Revision S (September 2016)

This revision includes the following updates:

- The Programming Interfaces diagram was updated (see [Figure 4-1](#))
- The 4-Wire Interface Pins table was updated (see [Table 4-1](#))
- The 2-Wire Interface Pins table was updated (see [Table 4-2](#))
- The PIC32MZ DA Power Connections diagram was updated (see [Figure 4-5](#))
- The Basic PIC32 Programming Interface Block Diagram was updated (see [Figure 5-2](#))
- The Note in [Section 5.3.2 “2-phase ICSP”](#) was updated
- The AC/DC Characteristics and Timing Requirements were updated (see [Table 21-1](#))
- Device IDs were added (see [Table C-1](#) through [Table C-11](#) in [Appendix C: “Device IDs”](#))

Revision T (May 2017)

This revision includes the following updates:

- Updated [Table 20-1](#), [Table 4-1](#), [Table 4-2](#)
- Updated [Figure 4-1](#), [Figure 4-2](#), [Figure 5-2](#)
- Added [Table C-12](#)
- Minor updates to text and formatting were incorporated throughout the document

PIC32

Revision U (July 2017)

This revision includes the following updates:

- Updated the PIC32MK devices (see [Section 2.1 “Devices with Dual Flash Panel and Dual Boot Regions”](#))
- Updated the PIC32MK devices in Code Memory Size (see [Table 5-1](#))
- Updated the PIC32MK devices in Device Configuration Register Mask Values of Currently Supported PIC32MX, PIC32MZ, and PIC32MK Devices (see [Table 18-1](#))
- Updated the Configuration Word Locations for PIC32MK Family Devices (see [Table 19-4](#))
- Added [TABLE 19-5: “Configuration Word Locations for PIC32MKXXXXXXH/G/J/K/L/MXX Family Devices”](#)
- Updated the PIC32MK General Purpose and Motor Control (GP/MC) Family Device IDs (see [Table C-11](#))
- In additions, minor updates to text and formatting were incorporated throughout the document

Revision V (July 2018)

This revision includes the following updates:

- In [Table 18-1](#): Renamed PIC32MK0256/0512XXG/H to PIC32MK0256/0512XXH/G/J. Also, updated Device Configuration Register Mask Values for PIC32MK0512/1024XXK/L/M and PIC32MK0512/1024XXH/G/J
- In [Table 19-5](#): Renamed family name from PIC32MKXXXXXXG/H/K/L/MXX to PIC32MKXXXXXXH/G/J/K/L/MXX
- In [Table C-11](#): Removed references to PIC32MKXXXXMCM/GPL/GPKXXX and PIC32MKXXXXMCH/GPGXXX
- In [Table C-12](#): Rearranged PIC32MKXXXX/MCM/GPL/GPKXXX devices. Added PIC32MKXXXX-MCJ/GPH/GPGXXX devices
- A note reference to the revision ID has been added from [Table C-1](#) to [Table C-12](#), which identifies the revision ID field within 32-bit device ID.

Revision W (October 2018)

This revision includes the following updates:

- Added note below [Table 13-1](#) and [Table 14-1](#)
- [Table C-13](#) content has been moved to [Table C-9](#)

Note the following details of the code protection feature on Microchip devices:

- Microchip products meet the specification contained in their particular Microchip Data Sheet.
- Microchip believes that its family of products is one of the most secure families of its kind on the market today, when used in the intended manner and under normal conditions.
- There are dishonest and possibly illegal methods used to breach the code protection feature. All of these methods, to our knowledge, require using the Microchip products in a manner outside the operating specifications contained in Microchip's Data Sheets. Most likely, the person doing so is engaged in theft of intellectual property.
- Microchip is willing to work with the customer who is concerned about the integrity of their code.
- Neither Microchip nor any other semiconductor manufacturer can guarantee the security of their code. Code protection does not mean that we are guaranteeing the product as "unbreakable."

Code protection is constantly evolving. We at Microchip are committed to continuously improving the code protection features of our products. Attempts to break Microchip's code protection feature may be a violation of the Digital Millennium Copyright Act. If such acts allow unauthorized access to your software or other copyrighted work, you may have a right to sue for relief under that Act.

Information contained in this publication regarding device applications and the like is provided only for your convenience and may be superseded by updates. It is your responsibility to ensure that your application meets with your specifications. MICROCHIP MAKES NO REPRESENTATIONS OR WARRANTIES OF ANY KIND WHETHER EXPRESS OR IMPLIED, WRITTEN OR ORAL, STATUTORY OR OTHERWISE, RELATED TO THE INFORMATION, INCLUDING BUT NOT LIMITED TO ITS CONDITION, QUALITY, PERFORMANCE, MERCHANTABILITY OR FITNESS FOR PURPOSE. Microchip disclaims all liability arising from this information and its use. Use of Microchip devices in life support and/or safety applications is entirely at the buyer's risk, and the buyer agrees to defend, indemnify and hold harmless Microchip from any and all damages, claims, suits, or expenses resulting from such use. No licenses are conveyed, implicitly or otherwise, under any Microchip intellectual property rights unless otherwise stated.

Microchip received ISO/TS-16949:2009 certification for its worldwide headquarters, design and wafer fabrication facilities in Chandler and Tempe, Arizona; Gresham, Oregon and design centers in California and India. The Company's quality system processes and procedures are for its PIC® MCUs and dsPIC® DSCs, KEELoQ® code hopping devices, Serial EEPROMs, microperipherals, nonvolatile memory and analog products. In addition, Microchip's quality system for the design and manufacture of development systems is ISO 9001:2000 certified.

**QUALITY MANAGEMENT SYSTEM
CERTIFIED BY DNV
= ISO/TS 16949 =**

Trademarks

The Microchip name and logo, the Microchip logo, AnyRate, AVR, AVR logo, AVR Freaks, BitCloud, chipKIT, chipKIT logo, CryptoMemory, CryptoRF, dsPIC, FlashFlex, flexPWR, Helder, JukeBlox, KeeLoq, Klear, LANCheck, LINK MD, maXStylus, maXTouch, MediaLB, megaAVR, MOST, MOST logo, MPLAB, OptoLyzer, PIC, picoPower, PICSTART, PIC32 logo, Prochip Designer, QTouch, SAM-BA, SpyNIC, SST, SST Logo, SuperFlash, tinyAVR, UNI/O, and XMEGA are registered trademarks of Microchip Technology Incorporated in the U.S.A. and other countries.

ClockWorks, The Embedded Control Solutions Company, EtherSynch, Hyper Speed Control, HyperLight Load, IntellIMOS, mTouch, Precision Edge, and Quiet-Wire are registered trademarks of Microchip Technology Incorporated in the U.S.A.

Adjacent Key Suppression, AKS, Analog-for-the-Digital Age, Any Capacitor, AnyIn, AnyOut, BodyCom, CodeGuard, CryptoAuthentication, CryptoAutomotive, CryptoCompanion, CryptoController, dsPICDEM, dsPICDEM.net, Dynamic Average Matching, DAM, ECAN, EtherGREEN, In-Circuit Serial Programming, ICSP, INICnet, Inter-Chip Connectivity, JitterBlocker, KlearNet, KlearNet logo, memBrain, Mindi, MiWi, motorBench, MPASM, MPF, MPLAB Certified logo, MPLIB, MPLINK, MultiTRAK, NetDetach, Omniscient Code Generation, PICDEM, PICDEM.net, PICkit, PICtail, PowerSmart, PureSilicon, QMatrix, REAL ICE, Ripple Blocker, SAM-ICE, Serial Quad I/O, SMART-I.S., SQI, SuperSwitcher, SuperSwitcher II, Total Endurance, TSHARC, USBCheck, VariSense, ViewSpan, WiperLock, Wireless DNA, and ZENA are trademarks of Microchip Technology Incorporated in the U.S.A. and other countries.

SQTP is a service mark of Microchip Technology Incorporated in the U.S.A.

Silicon Storage Technology is a registered trademark of Microchip Technology Inc. in other countries.

GestIC is a registered trademark of Microchip Technology Germany II GmbH & Co. KG, a subsidiary of Microchip Technology Inc., in other countries.

All other trademarks mentioned herein are property of their respective companies.

© 2018, Microchip Technology Incorporated, All Rights Reserved.
ISBN: 978-1-5224-3733-8



Worldwide Sales and Service

AMERICAS

Corporate Office
2355 West Chandler Blvd.
Chandler, AZ 85224-6199
Tel: 480-792-7200
Fax: 480-792-7277
Technical Support:
<http://www.microchip.com/support>
Web Address:
www.microchip.com

Atlanta

Duluth, GA
Tel: 678-957-9614
Fax: 678-957-1455

Austin, TX

Tel: 512-257-3370

Boston

Westborough, MA
Tel: 774-760-0087
Fax: 774-760-0088

Chicago

Itasca, IL
Tel: 630-285-0071
Fax: 630-285-0075

Dallas

Addison, TX
Tel: 972-818-7423
Fax: 972-818-2924

Detroit

Novi, MI
Tel: 248-848-4000

Houston, TX

Tel: 281-894-5983

Indianapolis

Noblesville, IN
Tel: 317-773-8323
Fax: 317-773-5453
Tel: 317-536-2380

Los Angeles

Mission Viejo, CA
Tel: 949-462-9523
Fax: 949-462-9608
Tel: 951-273-7800

Raleigh, NC

Tel: 919-844-7510

New York, NY

Tel: 631-435-6000

San Jose, CA

Tel: 408-735-9110
Tel: 408-436-4270

Canada - Toronto

Tel: 905-695-1980
Fax: 905-695-2078

ASIA/PACIFIC

Australia - Sydney
Tel: 61-2-9868-6733

China - Beijing
Tel: 86-10-8569-7000

China - Chengdu
Tel: 86-28-8665-5511

China - Chongqing
Tel: 86-23-8980-9588

China - Dongguan
Tel: 86-769-8702-9880

China - Guangzhou
Tel: 86-20-8755-8029

China - Hangzhou
Tel: 86-571-8792-8115

China - Hong Kong SAR
Tel: 852-2943-5100

China - Nanjing
Tel: 86-25-8473-2460

China - Qingdao
Tel: 86-532-8502-7355

China - Shanghai
Tel: 86-21-3326-8000

China - Shenyang
Tel: 86-24-2334-2829

China - Shenzhen
Tel: 86-755-8864-2200

China - Suzhou
Tel: 86-186-6233-1526

China - Wuhan
Tel: 86-27-5980-5300

China - Xian
Tel: 86-29-8833-7252

China - Xiamen
Tel: 86-592-2388138

China - Zhuhai
Tel: 86-756-3210040

ASIA/PACIFIC

India - Bangalore
Tel: 91-80-3090-4444

India - New Delhi
Tel: 91-11-4160-8631

India - Pune
Tel: 91-20-4121-0141

Japan - Osaka
Tel: 81-6-6152-7160

Japan - Tokyo
Tel: 81-3-6880-3770

Korea - Daegu
Tel: 82-53-744-4301

Korea - Seoul
Tel: 82-2-554-7200

Malaysia - Kuala Lumpur
Tel: 60-3-7651-7906

Malaysia - Penang
Tel: 60-4-227-8870

Philippines - Manila
Tel: 63-2-634-9065

Singapore
Tel: 65-6334-8870

Taiwan - Hsin Chu
Tel: 886-3-577-8366

Taiwan - Kaohsiung
Tel: 886-7-213-7830

Taiwan - Taipei
Tel: 886-2-2508-8600

Thailand - Bangkok
Tel: 66-2-694-1351

Vietnam - Ho Chi Minh
Tel: 84-28-5448-2100

EUROPE

Austria - Wels
Tel: 43-7242-2244-39
Fax: 43-7242-2244-393

Denmark - Copenhagen
Tel: 45-4450-2828
Fax: 45-4485-2829

Finland - Espoo
Tel: 358-9-4520-820

France - Paris
Tel: 33-1-69-53-63-20
Fax: 33-1-69-30-90-79

Germany - Garching
Tel: 49-8931-9700

Germany - Haan
Tel: 49-2129-3766400

Germany - Heilbronn
Tel: 49-7131-67-3636

Germany - Karlsruhe
Tel: 49-721-625370

Germany - Munich
Tel: 49-89-627-144-0
Fax: 49-89-627-144-44

Germany - Rosenheim
Tel: 49-8031-354-560

Israel - Ra'anana
Tel: 972-9-744-7705

Italy - Milan
Tel: 39-0331-742611
Fax: 39-0331-466781

Italy - Padova
Tel: 39-049-7625286

Netherlands - Drunen
Tel: 31-416-690399
Fax: 31-416-690340

Norway - Trondheim
Tel: 47-7288-4388

Poland - Warsaw
Tel: 48-22-3325737

Romania - Bucharest
Tel: 40-21-407-87-50

Spain - Madrid
Tel: 34-91-708-08-90
Fax: 34-91-708-08-91



Sweden - Gothenberg
Tel: 46-31-704-60-40

Sweden - Stockholm
Tel: 46-8-5090-4654



UK - Wokingham
Tel: 44-118-921-5800
Fax: 44-118-921-5820

Looking for pricing, stock, or lifecycle information?

Click below to explore more details on WIN SOURCE:

-  [View PIC32MX675F512L-80I/BG on WIN SOURCE](#)
-  [Microchip Technology Information](#)

Optimize Your Supply Chain with WIN SOURCE Solutions

-  Global Sourcing Solution
-  Obsolete Management
-  Cost Control Management
-  Shortage Management
-  Alternative Solution
-  Excess Inventory Management