



**THE DATASHEET OF
LTM2887CY-5S#PBF**



SPI/Digital or I²C μModule Isolator with Dual Adjustable 5V Regulators

FEATURES

- 6-Channel Logic Isolator: 2500V_{RMS} for 1 Minute
- UL-CSA Recognized cULus File #E151738
- Isolated DC Power:
 - 1.8V to 5V Logic Supply at Up to 100mA
 - 0.6V to 5V Auxiliary Supply at Up to 100mA
- No External Components Required
- SPI/Digital (LTM2887-S) or I²C (LTM2887-I) Options
- High Common Mode Transient Immunity: 30kV/μs
- High Speed Operation:
 - 10MHz Digital Isolation
 - 4MHz/8MHz SPI Isolation
 - 400kHz I²C Isolation
- 3.3V (LTM2887-3) or 5V (LTM2887-5) Operation
- 1.62V to 5.5V Logic Supply
- ±10kV ESD HBM Across the Isolation Barrier
- Maximum Continuous Working Voltage: 560V_{PEAK}
- Low Current Shutdown Mode (<10μA)
- Low Profile 15mm × 11.25mm × 3.42mm BGA Package

APPLICATIONS

- Isolated SPI or I²C Interfaces
- Industrial Systems
- Test and Measurement Equipment
- Breaking Ground Loops

DESCRIPTION

The LTM[®]2887 is a complete galvanic digital μModule[®] (micromodule) isolator. No external components are required. A single 3.3V or 5V supply powers both sides of the interface through an integrated, isolated DC/DC converter. A logic supply pin allows easy interfacing with different logic levels from 1.62V to 5.5V, independent of the main supply.

Available options are compliant with SPI and I²C (master mode only) specifications.

The isolated side includes two 5V nominal power supplies, including programmable current limit, each capable of providing more than 100mA of load current. The supplies may be adjusted from their nominal value using a single external resistor.

Coupled inductors and an isolation power transformer provide 2500V_{RMS} of isolation between the input and output logic interface. This device is ideal for systems where the ground loop is broken, allowing for a large common mode voltage range. Communication is uninterrupted for common mode transients greater than 30kV/μs.

LT, LT, LTC, LTM, Linear Technology, the Linear logo and μModule are registered trademarks of Analog Devices, Inc. All other trademarks are the property of their respective owners.

TYPICAL APPLICATION

Isolated 4MHz SPI Interface

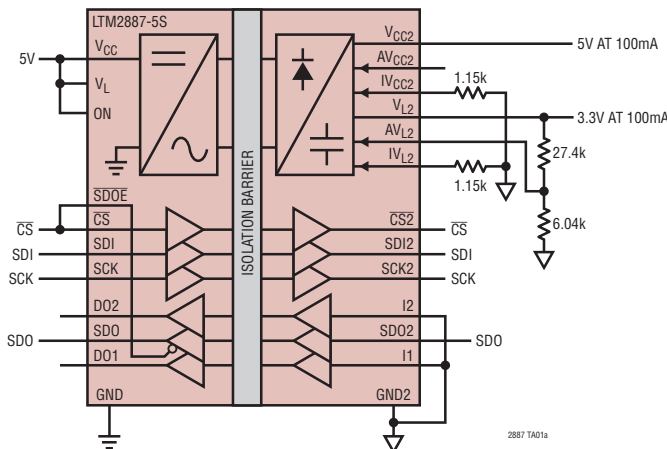

LTM2887 Operating Through 50kV/μs CM Transients

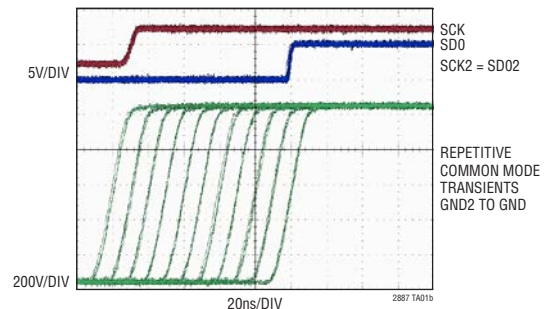

LTM2887

ABSOLUTE MAXIMUM RATINGS

(Note 1)

V_{CC} to GND	-0.3V to 6V
V_L to GND	-0.3V to 6V
V_{CC2} , AV_{CC2} , IV_{CC2} to GND2.....	-0.3V to 6V
V_{L2} , AV_{L2} , IV_{L2} to GND2	-0.3V to 6V
Logic Inputs	
DI1, SCK, SDI, \overline{CS} , SCL, SDA, \overline{SDOE} ,	
ON to GND	-0.3V to ($V_L + 0.3V$)
I1, I2, SDA2,	
SDO2 to GND2.....	-0.3V to ($V_{L2} + 0.3V$)

Logic Outputs

DO1, DO2, SDO to GND	-0.3V to ($V_L + 0.3V$)
O1, SCK2, SDI2, $\overline{CS2}$,	
SCL2 to GND2	-0.3V to ($V_{L2} + 0.3V$)

Operating Temperature Range (Note 4)

LTM2887C	0°C to 70°C
LTM2887I	-40°C to 85°C
LTM2887H	-40°C to 125°C

Maximum Internal Operating Temperature..... 125°C

Storage Temperature Range

Peak Body Reflow Temperature

PIN CONFIGURATION

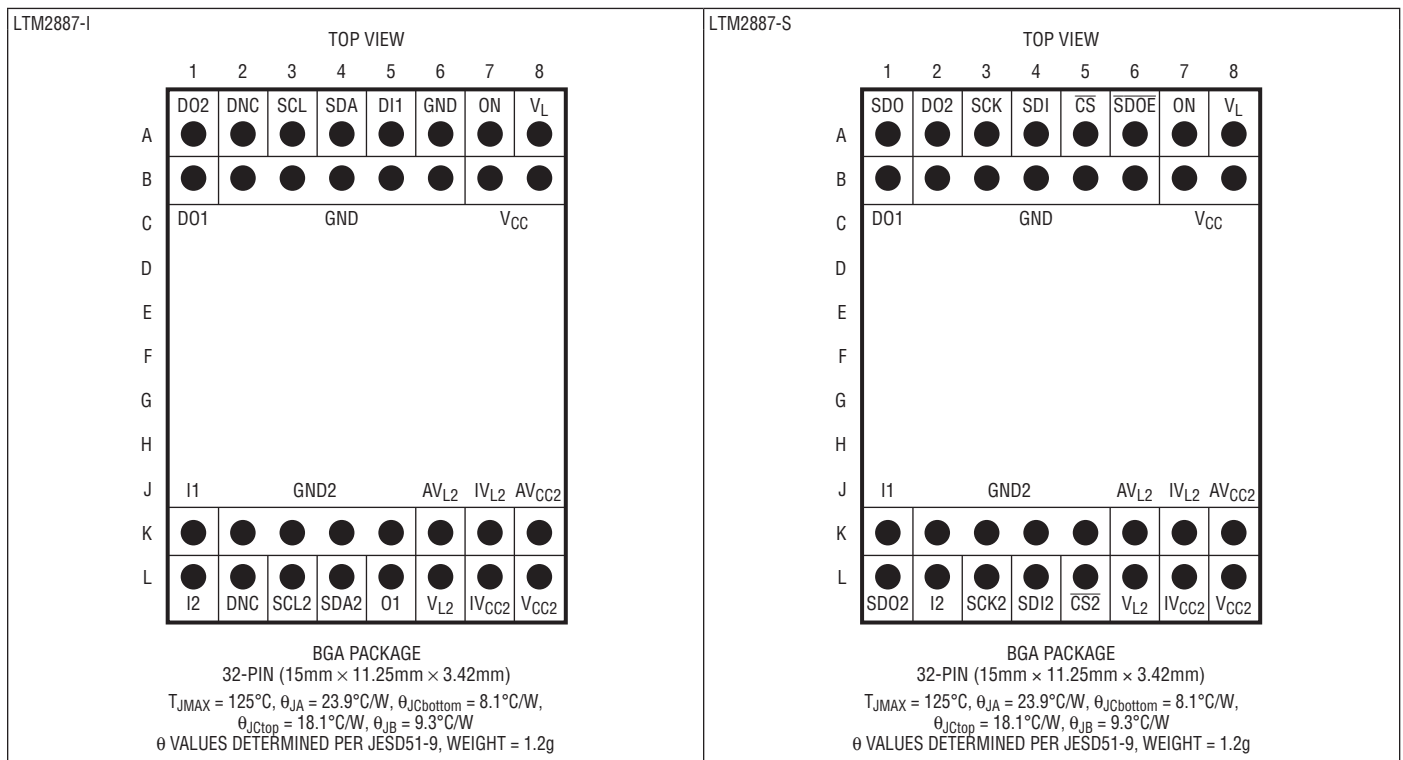

PRODUCT SELECTION GUIDE

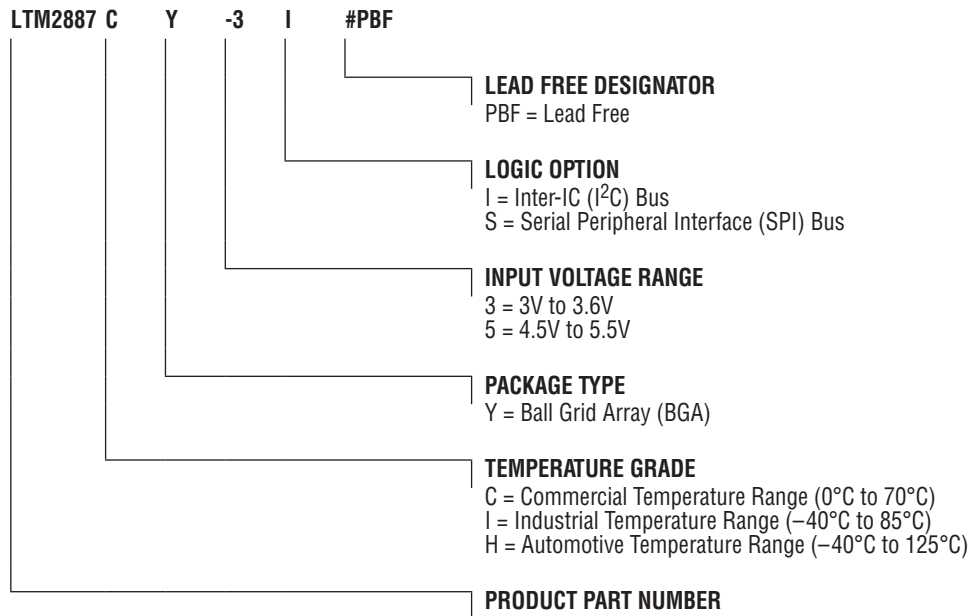

ORDER INFORMATION <http://www.linear.com/product/LTM2887#orderinfo>

PART NUMBER	PAD OR BALL FINISH	PART MARKING		PACKAGE TYPE	MSL RATING	INPUT VOLTAGE RANGE	LOGIC OPTION	TEMPERATURE RANGE			
		DEVICE	FINISH CODE								
LTM2887CY-3I#PBF	SAC305 (RoHS)	LTM2887Y-3I	e1	BGA	3	3V to 3.6V	I ² C	0°C to 70°C			
LTM2887IY-3I#PBF								-40°C to 85°C			
LTM2887HY-3I#PBF								-40°C to 125°C			
LTM2887CY-3S#PBF							SPI	0°C to 70°C			
LTM2887IY-3S#PBF								-40°C to 85°C			
LTM2887HY-3S#PBF								-40°C to 125°C			
LTM2887CY-5I#PBF		LTM2887Y-5I				e1	BGA	3	4.5V to 5.5V	I ² C	0°C to 70°C
LTM2887IY-5I#PBF											-40°C to 85°C
LTM2887HY-5I#PBF											-40°C to 125°C
LTM2887CY-5S#PBF										SPI	0°C to 70°C
LTM2887IY-5S#PBF											-40°C to 85°C
LTM2887HY-5S#PBF											-40°C to 125°C

- Device temperature grade is indicated by a label on the shipping container.
- Pad or ball finish code is per IPC/JEDEC J-STD-609.
- Terminal Finish Part Marking: www.linear.com/leadfree
- This product is not recommended for second side reflow. For more information, go to www.linear.com/BGA-assy
- Recommended BGA PCB Assembly and Manufacturing Procedures: www.linear.com/BGA-assy
- BGA Package and Tray Drawings: www.linear.com/packaging
- This product is moisture sensitive. For more information, go to: www.linear.com/BGA-assy

LTM2887

ELECTRICAL CHARACTERISTICS The ● denotes the specifications which apply over the specified operating temperature range, otherwise specifications are at $T_A = 25^\circ\text{C}$. LTM2887-3 $V_{CC} = 3.3\text{V}$, LTM2887-5 $V_{CC} = 5\text{V}$, $V_L = 3.3\text{V}$, and $\text{GND} = \text{GND2} = 0\text{V}$, $\text{ON} = V_L$ unless otherwise noted. Specifications apply to all options unless otherwise noted.

SYMBOL	PARAMETER	CONDITIONS	MIN	TYP	MAX	UNITS	
Input Supplies							
V_{CC}	Input Supply Range	LTM2887-3	● 3	3.3	3.6	V	
		LTM2887-5	● 4.5	5	5.5	V	
V_L	Logic Supply Range	LTM2887-S	● 1.62		5.5	V	
		LTM2887-I	● 3	5	5.5	V	
I_{CC}	Input Supply Current	$\text{ON} = 0\text{V}$	●	0	10	μA	
		LTM2887-3, $\text{ON} = V_L$, No Load	●	25	30	mA	
		LTM2887-5, $\text{ON} = V_L$, No Load	●	19	25	mA	
I_L	Logic Supply Current	$\text{ON} = 0\text{V}$	●	0	10	μA	
		LTM2887-S, $\text{ON} = V_L$		10		μA	
		LTM2887-I, $\text{ON} = V_L$			150	μA	
Output Supplies							
V_{CC2}	Regulated Output Voltage	No Load, AV_{CC2} Open	● 4.75	5	5.25	V	
	Output Voltage Operating Range	(Note 2)		0.6	5.5	V	
	Line Regulation	$I_{\text{LOAD}} = 1\text{mA}$, $\text{MIN} \leq V_{CC} \leq \text{MAX}$	●		1	6	mV
	Load Regulation	$I_{\text{LOAD}} = 1\text{mA}$ to 100mA	●		45	150	mV
	ADJ Pin Voltage	$I_{\text{LOAD}} = 1\text{mA}$ to 100mA	●	540	580	620	mV
	Voltage Ripple	$I_{\text{LOAD}} = 100\text{mA}$ (Note 2)			1		mV_{RMS}
	Efficiency	LTM2887-5, $I_{\text{LOAD}} = 100\text{mA}$ (Note 2)			62		%
I_{CC2}	Output Short Circuit Current	$V_{CC2} = 0\text{V}$, $\text{IV}_{CC2} = 0\text{V}$		200		mA	
	Internal Current Limit	$\Delta V_{CC2} = -5\%$, $\text{IV}_{CC2} = 0\text{V}$	●	100		mA	
	External Programmed Current Limit	$V_{CC2} = 5\text{V}$, $\text{R}(\text{IV}_{CC2}$ to $\text{GND2}) = 2.26\text{k}$	●	49	53	57	mA
		$V_{CC2} = 5\text{V}$, $\text{R}(\text{IV}_{CC2}$ to $\text{GND2}) = 1.5\text{k}$	●	71	79	87	mA
V_{L2}	Regulated Output Voltage	No Load, AV_{L2} Open	● 4.75	5	5.25	V	
	Output Voltage Operating Range	LTM2887-I (Note 2) LTM2887-S (Note 2)		3 1.8	5.5 5.5	V V	
	Line Regulation	$I_{\text{LOAD}} = 1\text{mA}$, $\text{MIN} \leq V_{CC} \leq \text{MAX}$	●		0.25	3	mV
	Load Regulation	$I_{\text{LOAD}} = 1\text{mA}$ to 100mA	●		25	100	mV
	ADJ Pin Voltage	$I_{\text{LOAD}} = 1\text{mA}$ to 100mA	●	540	580	620	mV
	Voltage Ripple	$I_{\text{LOAD}} = 100\text{mA}$ (Note 2)			1		mV_{RMS}
	Efficiency	LTM2887-5, $I_{\text{LOAD}} = 100\text{mA}$ (Note 2)			62		%
I_{L2}	Output Short Circuit Current	$V_{L2} = 0\text{V}$, $\text{IV}_{L2} = 0\text{V}$		200		mA	
	Current Limit	$\Delta V_{L2} = -5\%$, $\text{IV}_{L2} = 0\text{V}$	●	100		mA	
	External Programmed Current Limit	$V_{L2} = 5\text{V}$, $\text{R}(\text{IV}_{L2}$ to $\text{GND2}) = 2.26\text{k}$	●	49	53	57	mA
		$V_{L2} = 5\text{V}$, $\text{R}(\text{IV}_{L2}$ to $\text{GND2}) = 1.5\text{k}$	●	71	79	87	mA
V_{L2}	External Programmed Current Limit	$V_{L2} = 5\text{V}$, $\text{R}(\text{IV}_{L2}$ to $\text{GND2}) = 1.15\text{k}$	●	91	103	115	mA
		Logic/SPI					
		V_{ITH}	Input Threshold Voltage	ON , DI1, $\overline{\text{SDOE}}$, SCK, SDI, $\overline{\text{CS}}$ $1.62\text{V} \leq V_L < 2.35\text{V}$	●	$0.25 \cdot V_L$	$0.75 \cdot V_L$
ON , DI1, $\overline{\text{SDOE}}$, SCK, SDI, $\overline{\text{CS}}$ $2.35\text{V} \leq V_L$	●			$0.33 \cdot V_L$	$0.67 \cdot V_L$	V	
I1, I2, SDO2	●			$0.33 \cdot V_{L2}$	$0.67 \cdot V_{L2}$	V	
I_{INL}	Input Current				± 1	μA	

ELECTRICAL CHARACTERISTICS The ● denotes the specifications which apply over the specified operating temperature range, otherwise specifications are at $T_A = 25^\circ\text{C}$. LTM2887-3 $V_{CC} = 3.3\text{V}$, LTM2887-5 $V_{CC} = 5\text{V}$, $V_L = 3.3\text{V}$, and $\text{GND} = \text{GND2} = 0\text{V}$, $\text{ON} = V_L$ unless otherwise noted. Specifications apply to all options unless otherwise noted.

SYMBOL	PARAMETER	CONDITIONS	MIN	TYP	MAX	UNITS
V_{HYS}	Input Hysteresis			150		mV
V_{OH}	Output High Voltage	DO1, DO2, SDO $I_{LOAD} = -1\text{mA}$, $1.62\text{V} \leq V_L < 3\text{V}$ $I_{LOAD} = -4\text{mA}$, $3\text{V} \leq V_L \leq 5.5\text{V}$	●	$V_L - 0.4$		V
		O1, SCK2, SDI2, $\overline{\text{CS2}}$, $I_{LOAD} = -4\text{mA}$	●	$V_{L2} - 0.4$		V
V_{OL}	Output Low Voltage	DO1, DO2, SDO $I_{LOAD} = 1\text{mA}$, $1.62\text{V} \leq V_L < 3\text{V}$ $I_{LOAD} = 4\text{mA}$, $3\text{V} \leq V_L \leq 5.5\text{V}$	●		0.4	V
		O1, SCK2, SDI2, $\overline{\text{CS2}}$, $I_{LOAD} = 4\text{mA}$	●		0.4	V
I_{SC}	Short-Circuit Current	$0\text{V} \leq (\text{DO1}, \text{DO2}, \text{SDO}) \leq V_L$ $0\text{V} \leq (\text{O1}, \text{SCK2}, \text{SDI2}, \overline{\text{CS2}}) \leq V_{L2}$	●		± 85	mA
				± 60		mA
I²C						
V_{IL}	Low Level Input Voltage	SCL, SDA SDA2	● ●		$0.3 \cdot V_L$ $0.3 \cdot V_{L2}$	V V
V_{IH}	High Level Input Voltage	SCL, SDA SDA2	● ●	$0.7 \cdot V_L$ $0.7 \cdot V_{L2}$		V V
I_{INL}	Input Current	SCL, SDA = V_L or 0V SDA2 = V_{L2} , SDA2 = $V_{L2} = 0\text{V}$	● ●		± 1 ± 1	μA μA
V_{HYS}	Input Hysteresis	SCL, SDA SDA2		$0.05 \cdot V_L$ $0.05 \cdot V_{L2}$		mV mV
V_{OH}	Output High Voltage	SCL2, $I_{LOAD} = -2\text{mA}$ DO2, $I_{LOAD} = -2\text{mA}$	●	$V_{L2} - 0.4$ $V_L - 0.4$		V V
V_{OL}	Output Low Voltage	SDA, $I_{LOAD} = 3\text{mA}$ DO2, $I_{LOAD} = 2\text{mA}$ SCL2, $I_{LOAD} = 2\text{mA}$ SDA2, No Load, SDA = 0V , $4.5\text{V} \leq V_{L2} < 5.5\text{V}$ SDA2, No Load, SDA = 0V , $3\text{V} < V_{L2} < 4.5\text{V}$	● ● ● ● ●		0.4 0.4 0.4 0.45 0.55	V V V V V
C_{IN}	Input Pin Capacitance	SCL, SDA, SDA2 (Note 2)	●		10	pF
C_B	Bus Capacitive Load	SCL2, Standard Speed (Note 2) SCL2, Fast Speed SDA, SDA2, $\text{SR} \geq 1\text{V}/\mu\text{s}$, Standard Speed (Note 2) SDA, SDA2, $\text{SR} \geq 1\text{V}/\mu\text{s}$, Fast Speed	● ● ● ●		400 200 400 200	pF pF pF pF
	Minimum Bus Slew Rate	SDA, SDA2	●	1		V/ μs
I_{SC}	Short-Circuit Current	SDA2 = 0 , SDA = V_L $0\text{V} \leq \text{SCL2} \leq V_{L2}$ $0\text{V} \leq \text{DO2} \leq V_L$ SDA = 0 , SDA2 = V_{L2} SDA = V_L , SDA2 = 0	●	± 30 ± 30 6 -1.8	100	mA mA mA mA mA
ESD (HBM) (Note 2)						
	Isolation Boundary	(V_{CC2} , V_{L2} , GND2) to (V_{CC} , V_L , GND)			± 10	kV

SWITCHING CHARACTERISTICS The ● denotes the specifications which apply over the specified operating temperature range, otherwise specifications are at $T_A = 25^\circ\text{C}$. LTM2887-3 $V_{CC} = 3.3\text{V}$, LTM2887-5 $V_{CC} = 5\text{V}$, $V_L = 3.3\text{V}$, and $\text{GND} = \text{GND2} = 0\text{V}$, $\text{ON} = V_L$ unless otherwise noted. Specifications apply to all options unless otherwise noted.

SYMBOL	PARAMETER	CONDITIONS		MIN	TYP	MAX	UNITS
Logic							
	Maximum Data Rate	D11 → O1, Ix → DOx, $C_L = 15\text{pF}$ (Note 3)	●	10			MHz
$t_{\text{PHL}}, t_{\text{PLH}}$	Propagation Delay	$C_L = 15\text{pF}$ (Figure 1)	●	35	60	100	ns
t_{R}	Rise Time	$C_L = 15\text{pF}$ (Figure 1) LTM2887-I, DO2, $C_L = 15\text{pF}$ (Figure 1)	● ●		3 20	12.5 35	ns ns
t_{F}	Fall Time	$C_L = 15\text{pF}$ (Figure 1) LTM2887-I, DO2, $C_L = 15\text{pF}$ (Figure 1)	● ●		3 20	12.5 35	ns ns
SPI							
	Maximum Data Rate	Bidirectional Communication (Note 3) Unidirectional Communication (Note 3)	● ●	4 8			MHz MHz
$t_{\text{PHL}}, t_{\text{PLH}}$	Propagation Delay	$C_L = 15\text{pF}$ (Figure 1)	●	35	60	100	ns
t_{PWU}	Output Pulse Width Uncertainty	SDO, SDI2, $\overline{\text{CS}}2$ (Note 2)				±50	ns
t_{R}	Rise Time	$C_L = 15\text{pF}$ (Figure 1)	●		3	12.5	ns
t_{F}	Fall Time	$C_L = 15\text{pF}$ (Figure 1)	●		3	12.5	ns
$t_{\text{PZH}}, t_{\text{PZL}}$	Output Enable Time	$\overline{\text{SDOE}} = \downarrow$, $R_L = 1\text{k}\Omega$, $C_L = 15\text{pF}$ (Figure 2)	●			50	ns
$t_{\text{PHZ}}, t_{\text{PLZ}}$	Output Disable Time	$\overline{\text{SDOE}} = \uparrow$, $R_L = 1\text{k}\Omega$, $C_L = 15\text{pF}$ (Figure 2)	●			50	ns
I²C							
	Maximum Data Rate	(Note 3)	●	400			kHz
$t_{\text{PHL}}, t_{\text{PLH}}$	Propagation Delay	SCL → SCL2, $C_L = 15\text{pF}$ (Figure 1) SDA → SDA2, $R_L = \text{Open}$, $C_L = 15\text{pF}$ (Figure 3) SDA2 → SDA, $R_L = 1.1\text{k}\Omega$, $C_L = 15\text{pF}$ (Figure 3)	● ● ●		150 150 300	225 250 500	ns ns ns
t_{PWU}	Output Pulse Width Uncertainty	SDA, SDA2 (Note 2)				±50	ns
$t_{\text{HD,DAT}}$	Data Hold Time	(Note 2)			600		ns
t_{R}	Rise Time	SDA2, $C_L = 200\text{pF}$ (Figure 3) SDA, $R_L = 1.1\text{k}\Omega$, $C_L = 200\text{pF}$ (Figure 3) SCL2, $C_L = 200\text{pF}$ (Figure 1)	● ● ●	40 40		300 250 250	ns ns ns
t_{F}	Fall Time	SDA2, $C_L = 200\text{pF}$ (Figure 3) SDA, $R_L = 1.1\text{k}\Omega$, $C_L = 200\text{pF}$ (Figure 3) SCL2, $C_L = 200\text{pF}$ (Figure 1)	● ● ●	40 40		250 250 250	ns ns ns
t_{SP}	Pulse Width of Spikes Suppressed by Input Filter		●	0		50	ns
Power Supply							
	Power-Up Time	ON = \uparrow to $V_{\text{CC}2}$ (Min) ON = \uparrow to $V_{\text{L}2}$ (Min)	● ●		3 3	5 5	ms ms

ISOLATION CHARACTERISTICS $T_A = 25^\circ\text{C}$.

SYMBOL	PARAMETER	CONDITIONS	MIN	TYP	MAX	UNITS
V_{ISO}	Rated Dielectric Insulation Voltage	1 Minute, Derived from 1 Second Test 1 Second (Notes 5, 6)	2500 3000			V_{RMS} V_{RMS}
	Common Mode Transient Immunity	LTM2887-3 $V_{CC} = 3.3\text{V}$, LTM2887-5 $V_{CC} = 5\text{V}$, $V_L = 0\text{N} = 3.3\text{V}$, $V_{CM} = 1\text{kV}$, $\Delta t = 33\text{ns}$ (Note 2)	30			$\text{kV}/\mu\text{s}$
V_{IORM}	Maximum Continuous Working Voltage	(Notes 2, 5)	560 400			V_{PEAK} V_{DC} V_{RMS}
	Partial Discharge	$V_{PD} = 750V_{RMS}$ (Note 5)			5	pC
	Input to Output Resistance	(Notes 2, 5)	10^9			Ω
CTI	Comparative Tracking Index	IEC 60112 (Note 2)	600			V_{RMS}
	Depth of Erosion	IEC 60112 (Note 2)		0.017		mm
DTI	Distance Through Insulation	(Note 2)		0.06		mm
	Input to Output Capacitance	(Notes 2, 5)		6		pF
	Creepage Distance	(Note 2)		9.5		mm

Note 1: Stresses beyond those listed under Absolute Maximum Ratings may cause permanent damage to the device. Exposure to any Absolute Maximum Rating condition for extended periods may affect device reliability and lifetime.

Note 2: Guaranteed by design and not subject to production test.

Note 3: Maximum Data rate is guaranteed by other measured parameters and is not tested directly.

Note 4: This Module includes overtemperature protection that is intended to protect the device during momentary overload conditions. Junction temperature will exceed 125°C when overtemperature protection is active. Continuous operation above specified maximum operating junction temperature may result in device degradation or failure.

Note 5: Device considered a 2-terminal device. Pin group A1 through B8 shorted together and pin group K1 through L8 shorted together.

Note 6: The rated dielectric insulation voltage should not be interpreted as a continuous voltage rating.

LTM2887

TYPICAL PERFORMANCE CHARACTERISTICS $T_A = 25^\circ\text{C}$, LTM2887-3 $V_{CC} = 3.3\text{V}$, LTM2887-5 $V_{CC} = 5\text{V}$, $V_L = 3.3\text{V}$, $\text{GND} = \text{GND2} = 0\text{V}$, $\text{ON} = V_L$ unless otherwise noted.

V_{CC} Supply Current vs Temperature

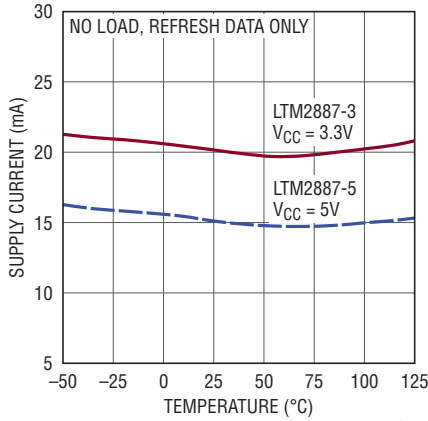

V_{CC2} and V_{L2} Voltage vs Equal Load Current

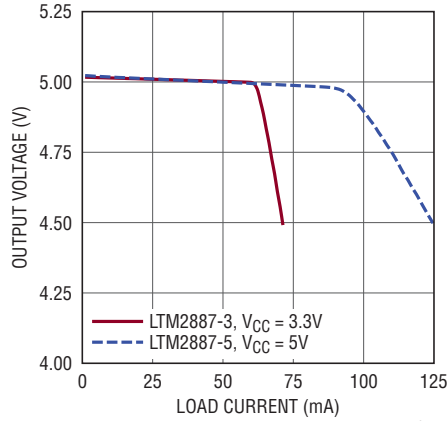

V_{CC2} or V_{L2} Output Voltage vs Input Voltage and Load Current

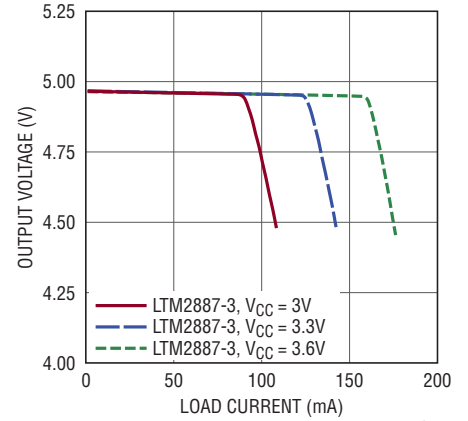

V_{CC2} or V_{L2} Output Voltage vs Input Voltage and Load Current

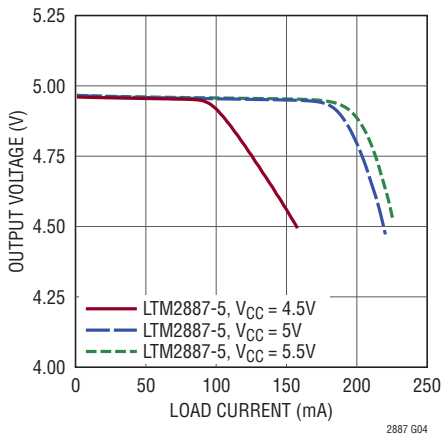

V_{CC2} or V_{L2} Load Regulation vs Temperature

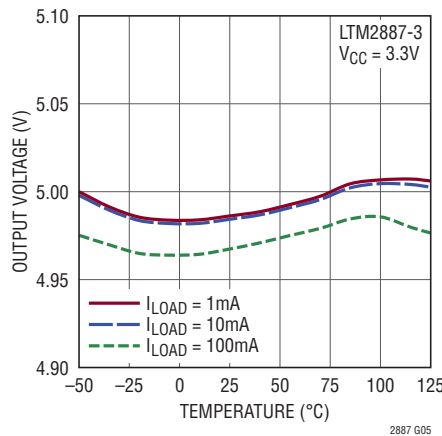

V_{CC2} or V_{L2} Load Regulation vs Temperature

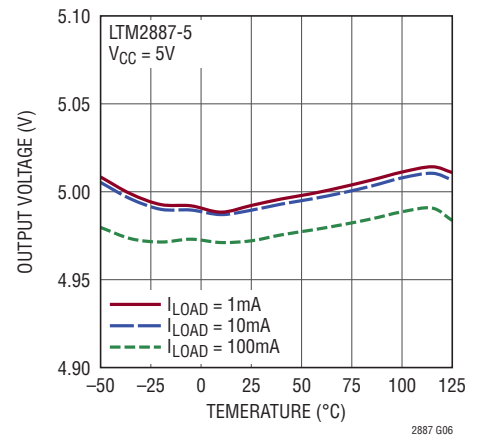

V_{CC2} or V_{L2} Efficiency

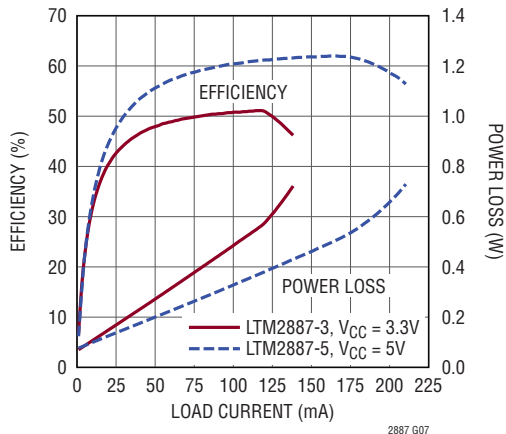

V_{CC2} or V_{L2} Voltage and V_{CC} Input Current vs Load Current

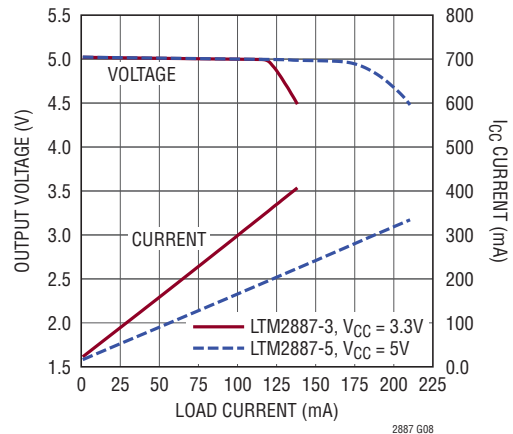

TYPICAL PERFORMANCE CHARACTERISTICS $T_A = 25^\circ\text{C}$, LTM2887-3 $V_{CC} = 3.3\text{V}$, LTM2887-5 $V_{CC} = 5\text{V}$, $V_L = 3.3\text{V}$, $\text{GND} = \text{GND2} = 0\text{V}$, $\text{ON} = V_L$ unless otherwise noted.

V_{CC2} or V_{L2} Transient Response
100mA Load Step

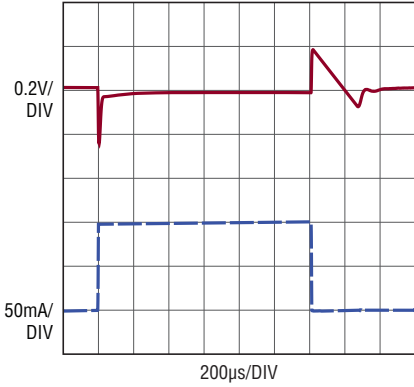

2887 G09

V_{CC2} or V_{L2} Ripple

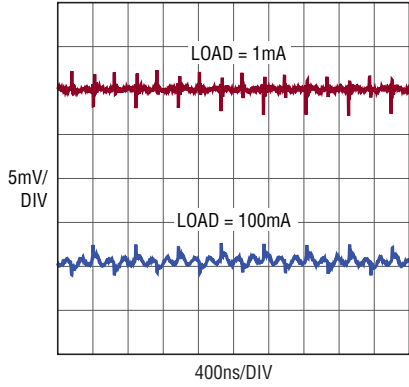

2887 G10

V_{CC2} or V_{L2} Noise

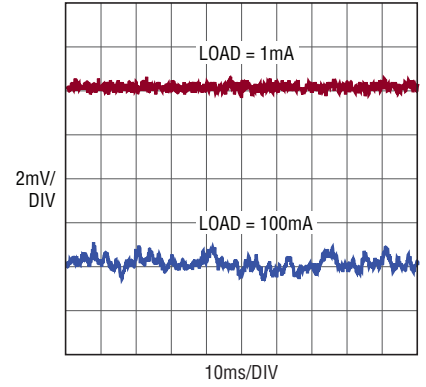

2887 G11

V_{CC} Supply Current vs Single Channel Data Rate

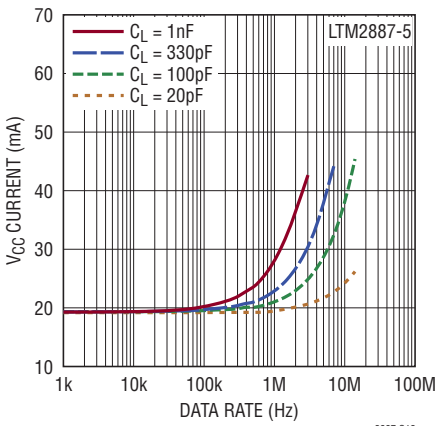

2887 G12

Logic Input Threshold vs V_L Supply Voltage

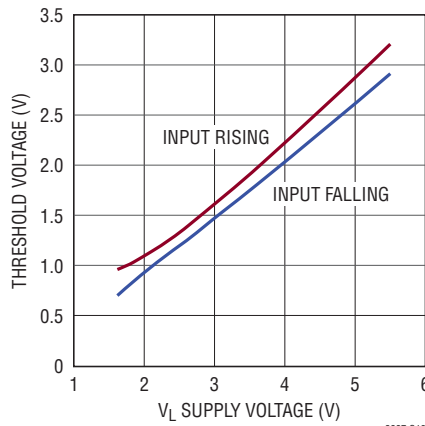

2887 G13

Logic Output Voltage vs Load Current

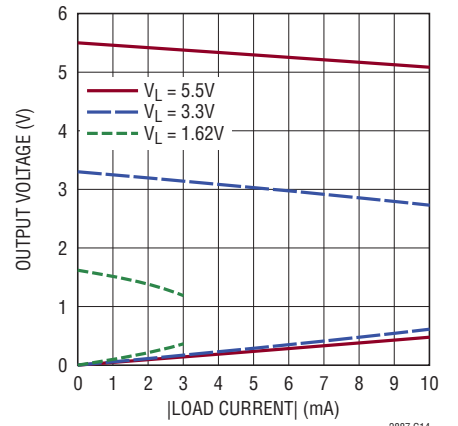

2887 G14

Power On Sequence

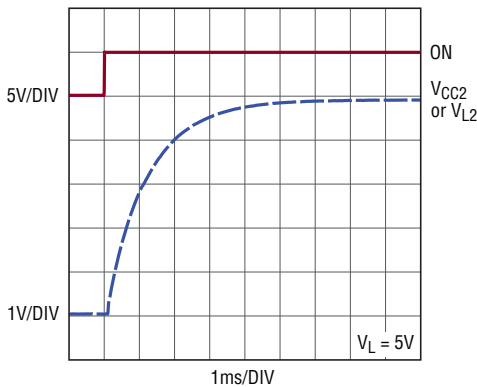

2887 G15

V_{CC2} and V_{L2} Efficiency with Equal Load Current

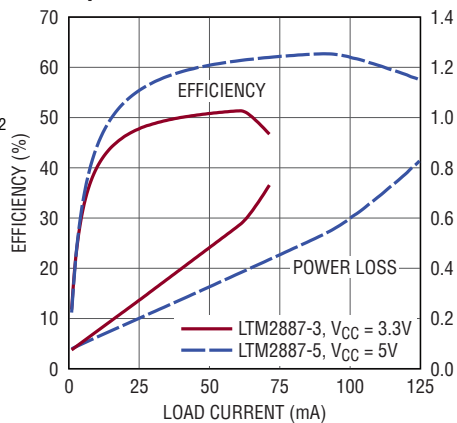

2887 G16

Derating for 125°C Maximum Internal Operating Temperature

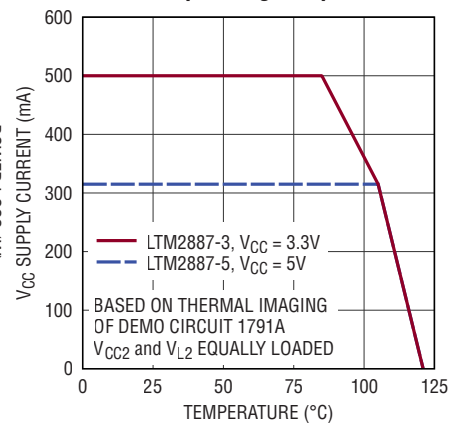

2887 G17

PIN FUNCTIONS

LTM2887-I Logic Side

DO2 (A1): Digital Output, Referenced to V_L and GND. Logic output connected to I2 through isolation barrier. Under the condition of an isolation communication failure this output is in a high impedance state.

DNC (A2): Do Not Connect. Pin connected internally.

SCL (A3): Serial I²C Clock Input, Referenced to V_L and GND. Logic input connected to isolated side SCL2 pin through isolation barrier. Clock is unidirectional from logic to isolated side. Do not float.

SDA (A4): Serial I²C Data Pin, Referenced to V_L and GND. Bidirectional logic pin connected to isolated side SDA2 pin through isolation barrier. Under the condition of an isolation communication failure this pin is in a high impedance state. Do not float.

DI1 (A5): Digital Input, Referenced to V_L and GND. Logic input connected to O1 through isolation barrier. The logic state on DI1 translates to the same logic state on O1. Do not float.

GND (A6, B2 to B6): Circuit Ground.

ON (A7): Enable, Referenced to V_L and GND. Enables power and data communication through the isolation barrier. If ON is high the part is enabled and power and communications are functional to the isolated side. If ON is low the logic side is held in reset, all digital outputs are in a high impedance state, and the isolated side is unpowered. Do not float.

V_L (A8): Logic Supply. Interface supply voltage for pins DI1, SCL, SDA, DO1, DO2, and ON. Operating voltage is 1.62V to 5.5V. Internally bypassed with 1 μ F.

DO1 (B1): Digital Output, Referenced to V_L and GND. Logic output connected to I1 through isolation barrier. Under the condition of an isolation communication failure this output is in a high impedance state.

V_{CC} (B7 to B8): Supply Voltage. Operating voltage is 3V to 3.6V for LTM2887-3 and 4.5V to 5.5V for LTM2887-5. Internally bypassed with 2.2 μ F.

LTM2887-I Isolated Side

I2 (L1): Digital Input, Referenced to V_{L2} and GND2. Logic input connected to DO2 through isolation barrier. The logic state on I2 translates to the same logic state on DO2. Do not float.

DNC (L2): Do Not Connect. Pin connected internally.

SCL2 (L3): Serial I²C Clock Output, Referenced to V_{L2} and GND2. Logic output connected to logic side SCL pin through isolation barrier. Clock is unidirectional from logic to isolated side. SCL2 has a push-pull output stage, do not connect an external pull-up device. Under the condition of an isolation communication failure this output defaults to a high state.

SDA2 (L4): Serial I²C Data Pin, Referenced to V_{L2} and GND2. Bidirectional logic pin connected to logic side SDA pin through isolation barrier. Output is biased high by a 1.8mA current source. Do not connect an external pull-up device to SDA2. Under the condition of an isolation communication failure this output defaults to a high state.

O1 (L5): Digital Output, Referenced to V_{L2} and GND2. Logic output connected to DI1 through isolation barrier. Under the condition of an isolation communication failure O1 defaults to a high state.

V_{L2} (L6): 3V to 5.5V Adjustable Isolated Supply Voltage. Internally generated from V_{CC} by an isolated DC/DC converter and regulated to 5V with no external components. Internally bypassed with 4.7 μ F.

IV_{CC2} (L7): V_{CC2} precision current limit adjust pin. Current limit threshold is set by connecting a resistor between IV_{CC2} and GND2. For detailed information on how to set the current limit resistor value, see the Application Information section. If not used, tie IV_{CC2} to GND2. Internally bypassed with 10nF.

V_{CC2} (L8): 0.6V to 5.5V Adjustable Isolated Supply Voltage. Internally generated from V_{CC} by an isolated DC/DC converter and regulated to 5V with no external components. Internally bypassed with 4.7 μ F.

I1 (K1): Digital Input, Referenced to V_{L2} and GND2. Logic input connected to DO1 through isolation barrier. The logic state on I1 translates to the same logic state on DO1. Do not float.

GND2 (K2 to K5): Isolated Ground.

PIN FUNCTIONS

LTM2887-I Isolated Side

AV_{L2} (K6): 5V Nominal Isolated Supply Voltage Adjust. The adjust pin voltage is 600mV referenced to GND2. See Applications Information section for details.

IV_{L2} (K7): V_{L2} precision current limit adjust pin. Current limit threshold is set by connecting a resistor between IV_{L2} and GND2. For detailed information on how to set the current limit resistor value, see the Application Information section. If not used, tie IV_{L2} to GND2. Internally bypassed with 10nF.

AV_{CC2} (K8): 5V Nominal Isolated Supply Voltage Adjust. The adjust pin voltage is 600mV referenced to GND2. See Applications Information section for details.

LTM2887-S Logic Side

SDO (A1): Serial SPI Digital Output, Referenced to V_L and GND. Logic output connected to isolated side SDO2 pin through isolation barrier. Under the condition of an isolation communication failure this output is in a high impedance state.

DO2 (A2): Digital Output, Referenced to V_L and GND. Logic output connected to I2 through isolation barrier. Under the condition of an isolation communication failure this output is in a high impedance state.

SCK (A3): Serial SPI Clock Input, Referenced to V_L and GND. Logic input connected to isolated side SCK2 pin through isolation barrier. Do not float.

SDI (A4): Serial SPI Data Input, Referenced to V_L and GND. Logic input connected to isolated side SDI2 pin through isolation barrier. Do not float.

\overline{CS} (A5): Serial SPI Chip Select, Referenced to V_L and GND. Logic input connected to isolated side $\overline{CS2}$ pin through isolation barrier. Do not float.

\overline{SDOE} (A6): Serial SPI Data Output Enable, Referenced to V_L and GND. A logic high on \overline{SDOE} places the logic side SDO pin in a high impedance state, a logic low enables the output. Do not float.

ON (A7): Enable, Referenced to V_L and GND. Enables power and data communication through the isolation barrier. If ON is high the part is enabled and power and

communications are functional to the isolated side. If ON is low the logic side is held in reset, all digital outputs are in a high impedance state, and the isolated side is unpowered. Do not float.

V_L (A8): Logic Supply. Interface supply voltage for pins SDI, SCK, SDO, \overline{SDOE} , DO1, DO2, \overline{CS} , and ON. Operating voltage is 1.62V to 5.5V. Internally bypassed with 1 μ F.

DO1 (B1): Digital Output, Referenced to V_L and GND. Logic output connected to I1 through isolation barrier. Under the condition of an isolation communication failure this output is in a high impedance state.

GND (B2 to B6): Circuit Ground.

V_{CC} (B7 to B8): Supply Voltage. Operating voltage is 3V to 3.6V for LTM2887-3 and 4.5V to 5.5V for LTM2887-5. Internally bypassed with 2.2 μ F.

LTM2887-S Isolated Side

SDO2 (L1): Serial SPI Digital Input, Referenced to V_{L2} and GND2. Logic input connected to logic side SDO pin through isolation barrier. Do not float.

I2 (L2): Digital Input, Referenced to V_{L2} and GND2. Logic input connected to DO2 through isolation barrier. The logic state on I2 translates to the same logic state on DO2. Do not float.

SCK2 (L3): Serial SPI Clock Output, Referenced to V_{L2} and GND2. Logic output connected to logic side SCK pin through isolation barrier. Under the condition of an isolation communication failure this output defaults to a low state.

SDI2 (L4): Serial SPI Data Output, Referenced to V_{L2} and GND2. Logic output connected to logic side SDI pin through isolation barrier. Under the condition of an isolation communication failure this output defaults to a low state.

$\overline{CS2}$ (L5): Serial SPI Chip Select, Referenced to V_{L2} and GND2. Logic output connected to logic side \overline{CS} pin through isolation barrier. Under the condition of an isolation communication failure this output defaults to a high state.

V_{L2} (L6): 1.8V to 5.5V Adjustable Isolated Supply Voltage. Internally generated from V_{CC} by an isolated DC/DC converter and regulated to 5V with no external components. Internally bypassed with 4.7 μ F.

PIN FUNCTIONS

LTM2887-S Isolated Side

IV_{CC2} (L7): V_{CC2} precision current limit adjust pin. Current limit threshold is set by connecting a resistor between IV_{CC2} and GND2. For detailed information on how to set the current limit resistor value, please see the Application Information section. If not used, tie IV_{CC2} to GND2. Internally bypassed with 10nF.

V_{CC2} (L8): 0.6V to 5.5V Adjustable Isolated Supply Voltage. Internally generated from V_{CC} by an isolated DC/DC converter and regulated to 5V with no external components. Internally bypassed with 4.7μF.

I1 (K1): Digital Input, Referenced to V_{L2} and GND2. Logic input connected to DO1 through isolation barrier. The logic state on I1 translates to the same logic state on DO1. Do not float.

GND2 (K2 to K5): Isolated Ground.

AV_{L2} (K6): 5V Nominal Isolated Supply Voltage Adjust. The adjust pin voltage is 600mV Referenced to GND2. See Applications Information section for details..

IV_{L2} (K7): V_{L2} precision current limit adjust pin. Current limit threshold is set by connecting a resistor between IV_{L2} and GND2. For detailed information on how to set the current limit resistor value, please see the Application Information section. If not used, tie IV_{L2} to GND2. Internally bypassed with 10nF.

AV_{CC2} (K8): 5V Nominal Isolated Supply Voltage Adjust. The adjust pin voltage is 600mV Referenced to GND2. See Applications Information section for details.

BLOCK DIAGRAMS

LTM2887-I

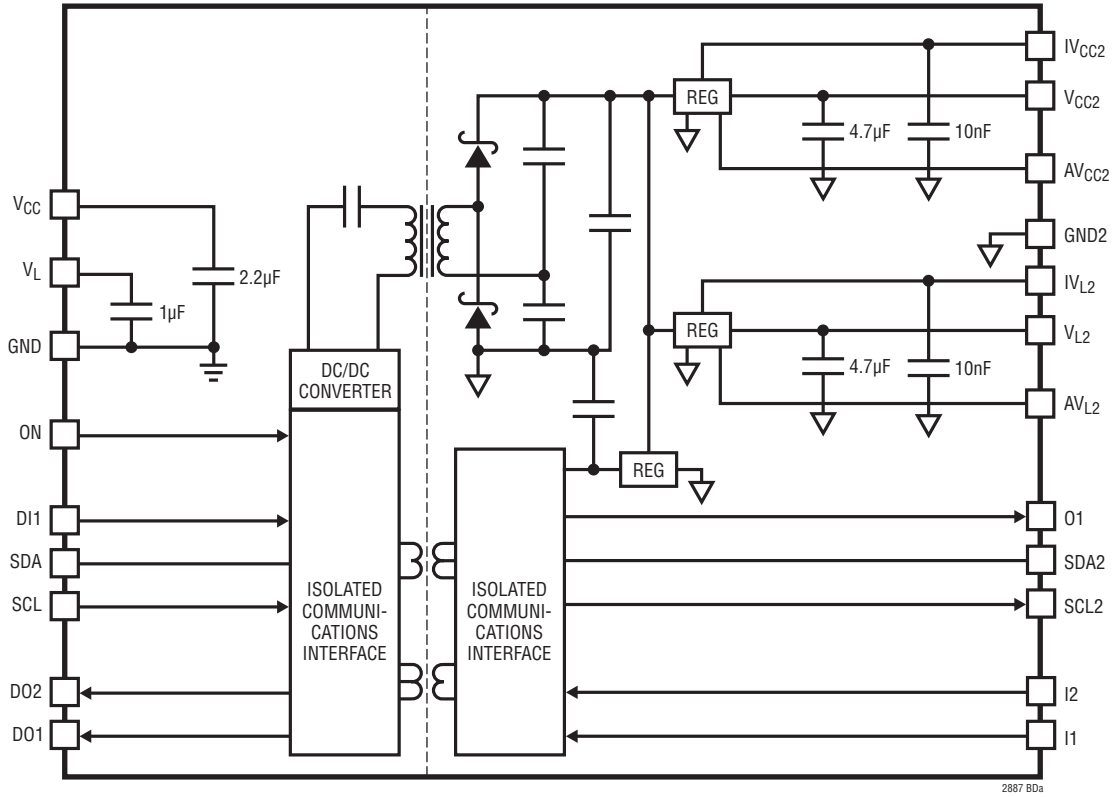

BLOCK DIAGRAMS

LTM2887-S

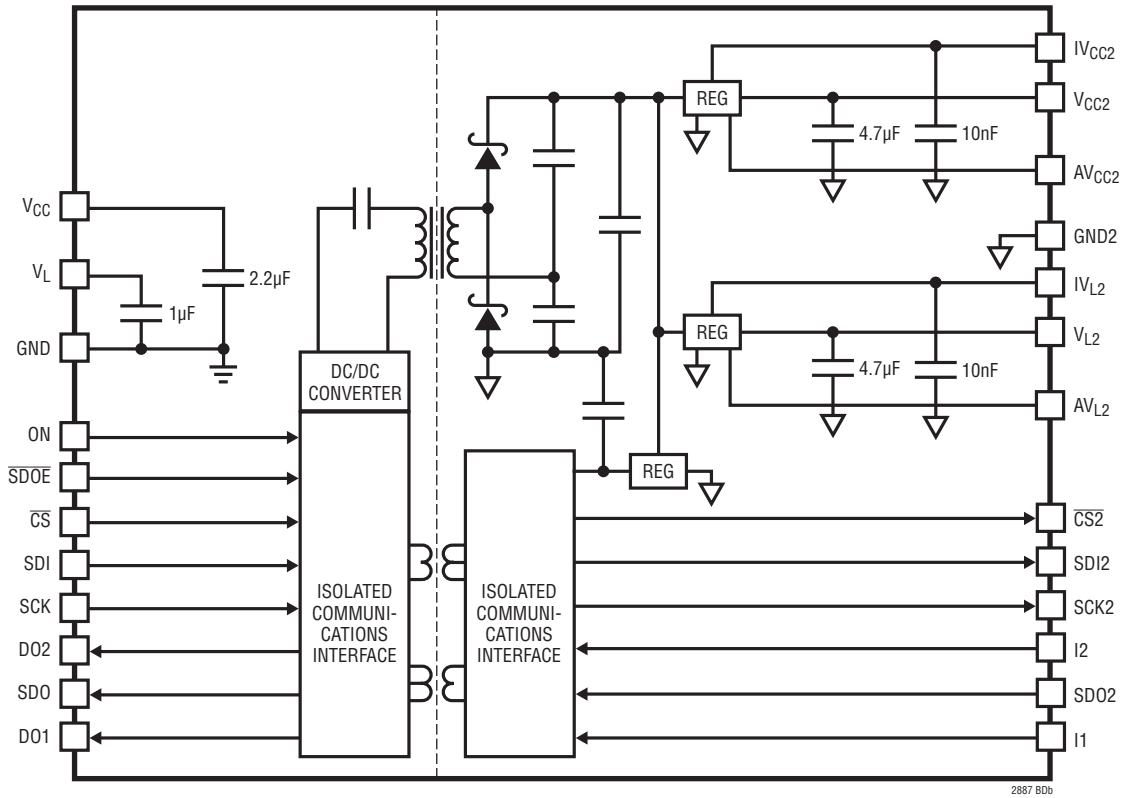

TEST CIRCUITS

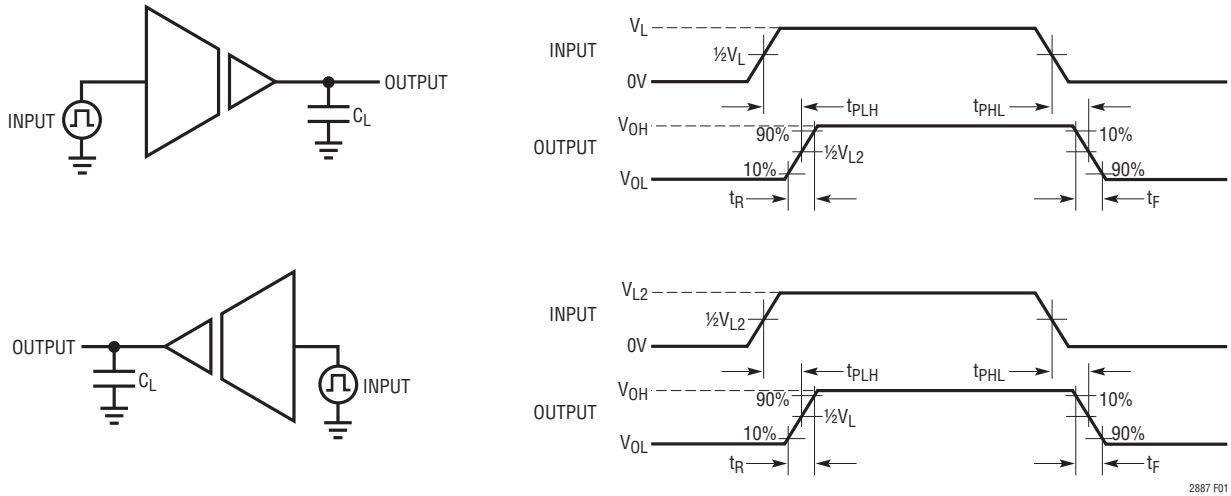

Figure 1. Logic Timing Measurements

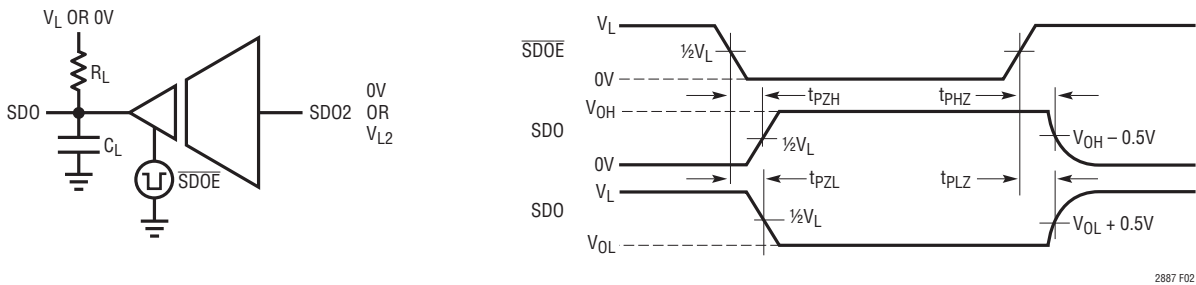

Figure 2. Logic Enable/Disable Time

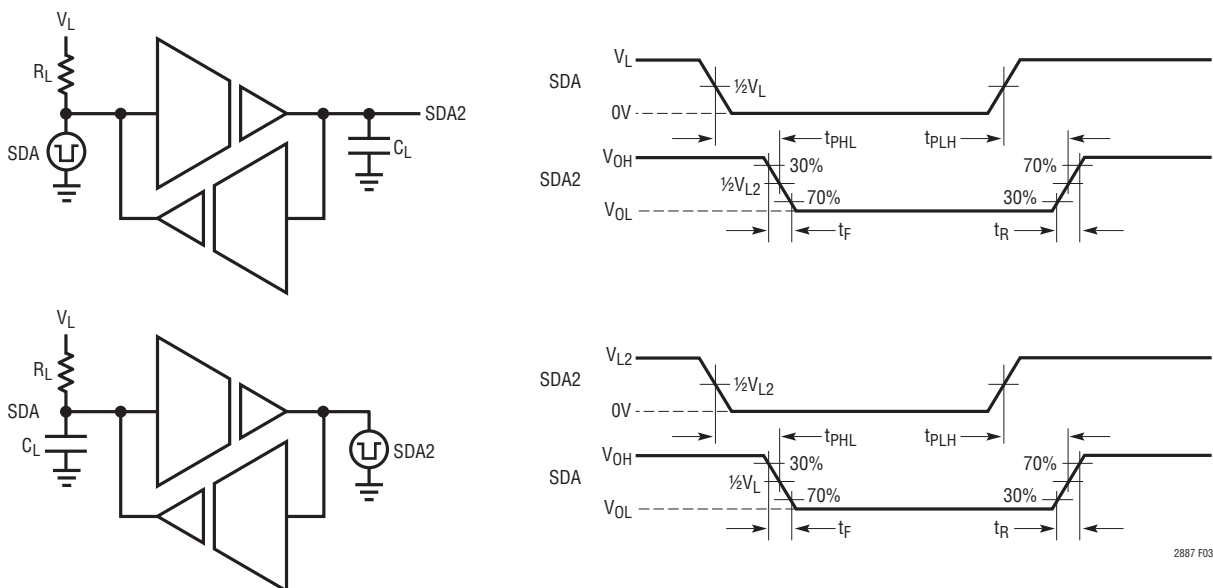

Figure 3. I²C Timing Measurements

APPLICATIONS INFORMATION

Overview

The LTM2887 digital μ Module isolator provides a galvanically-isolated robust logic interface, powered by an integrated, regulated DC/DC converter, complete with decoupling capacitors. The LTM2887 is ideal for use in networks where grounds can take on different voltages. Isolation in the LTM2887 blocks high voltage differences, eliminates ground loops and is extremely tolerant of common mode transients between ground planes. Error-free operation is maintained through common mode events greater than 30kV/ μ s providing excellent noise isolation.

Isolator μ Module Technology

The LTM2887 utilizes isolator μ Module technology to translate signals and power across an isolation barrier. Signals on either side of the barrier are encoded into pulses and translated across the isolation boundary using coreless transformers formed in the μ Module substrate. This system, complete with data refresh, error checking, safe shutdown on fail, and extremely high common mode immunity, provides a robust solution for bidirectional signal isolation. The μ Module technology provides the means to combine the isolated signaling with multiple regulators and a powerful isolated DC/DC converter in one small package.

DC/DC Converter

The LTM2887 contains a fully integrated DC/DC converter, including the transformer, so that no external components are necessary. The logic side contains a full-bridge driver, running at 1.6MHz, and is AC-coupled to a single transformer primary. A series DC blocking capacitor prevents transformer saturation due to driver duty cycle imbalance. The transformer scales the primary voltage, and is rectified by a full-wave voltage doubler. This topology allows for a single diode drop, as in a center tapped full-wave bridge, and eliminates transformer saturation caused by secondary imbalances.

Three low dropout regulators (LDOs) are connected to the output of the voltage doubler. One LDO powers the internal circuitry and is not available externally. The other two LDOs provide regulated 5V nominally for the V_{CC2} and V_{L2} outputs. V_{L2} corresponds to the voltage levels on the isolated logic pins.

The internal power solution is sufficient to provide a minimum of 100mA of current from V_{CC2} and V_{L2} . V_{CC} is bypassed with 2.2 μ F, V_{CC2} and V_{L2} are each bypassed with 4.7 μ F.

V_L Logic Supply

A separate logic supply pin V_L allows the LTM2887 to interface with any logic signal from 1.62V to 5.5V as shown in Figure 4. Simply connect the desired logic supply to V_L .

There is no interdependency between V_{CC} and V_L ; they may simultaneously operate at any voltage within their specified operating ranges and sequence in any order. V_L is bypassed internally by a 1 μ F capacitor.

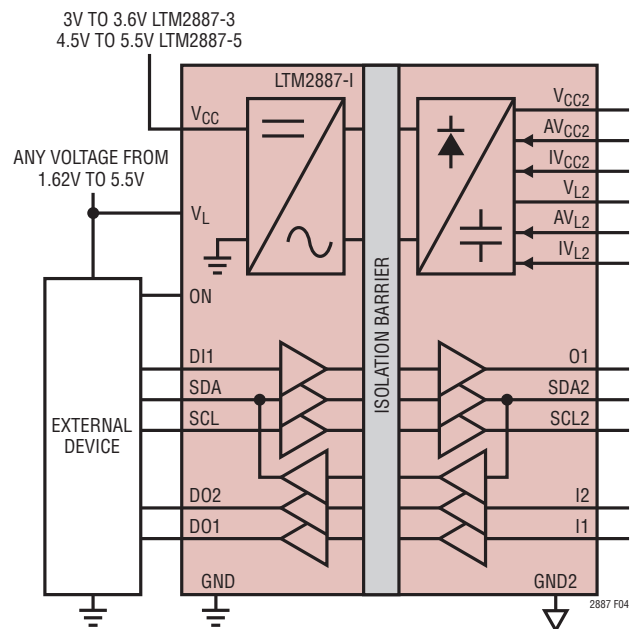

Figure 4. V_{CC} and V_L Are Independent

Hot-Plugging Safely

Caution must be exercised in applications where power is plugged into the LTM2887's power supplies, V_{CC} or V_L , due to the integrated ceramic decoupling capacitors. The parasitic cable inductance along with the high Q characteristics of ceramic capacitors can cause substantial ringing which could exceed the maximum voltage ratings and damage the LTM2887. Refer to Linear Technology Application Note 88, entitled Ceramic Input Capacitors Can Cause Overvoltage Transients for a detailed discussion and mitigation of this phenomenon.

APPLICATIONS INFORMATION

Isolated Supply Adjustable Operation

The two isolated power rails may be adjusted by connection of external resistive dividers. The unadjusted output voltages represent the maximums for guaranteed performance. Figure 5 illustrates configuration of the output power rails for $V_{CC2} = 3.3V$, and $V_{L2} = 2.5V$.

The output adjustment range for V_{CC2} is 0.6V to 5.5V. Output voltage is calculated by:

$$V_{CC2} = 0.6V(1 + R2/R1)$$

Adjustment range for V_{L2} is 3V to 5.5V for the LTM2887-I, and 1.8V to 5.5V for the LTM2887-S. Output voltage is calculated by:

$$V_{L2} = 0.6V(1 + R5/R4)$$

The value of R1 or R4 should be no greater than 6.04k to minimize errors in the output voltage caused by the adjust pin bias currents and internal voltage dividers.

Operation at low output voltages may result in thermal shutdown due to low dropout regulator power dissipation.

Isolated Supply Programmable Current Limit

The IV_{CC2} pin and IV_{L2} pin allow programming of the maximum current available from V_{CC2} and V_{L2} respectively. The current adjustments may be used to limit the

maximum output power, insuring that either voltage rail does not collapse if the opposing rail is loaded beyond its capability. The current limit threshold (I_{LIMIT}) is set by attaching a resistor (R_{IMAX}) from IV_{CC2} or IV_{L2} to GND2:

$$R_{IMAX} = [119.22 - (0.894 \cdot (V_{CC2}, V_{L2}))] / I_{LIMIT}$$

The accuracy of this equation for setting the resistor value is approximately $\pm 1\%$. Unit values are amps, volts, and ohms. Figure 5 shows the current limit programmed for 75mA on V_{CC2} and 25mA on V_{L2} . If the external programmable current limit is not needed, the IV_{CC2} pin or IV_{L2} must be connected to GND2. The current limit pins are internally decoupled with 10nF capacitors.

Channel Timing Uncertainty

Multiple channels are supported across the isolation boundary by encoding and decoding of the inputs and outputs. Up to three signals in each direction are assembled as a packet and transferred across the isolation barrier. The time required to transfer all 3 bits is 100ns maximum, and sets the limit for how often a signal can change on the opposite side of the barrier. Encoding transmission is independent for each data direction. The technique used assigns SCK or SCL on the logic side, and SDO2 or I2 on the isolated side, the highest priority such that there is

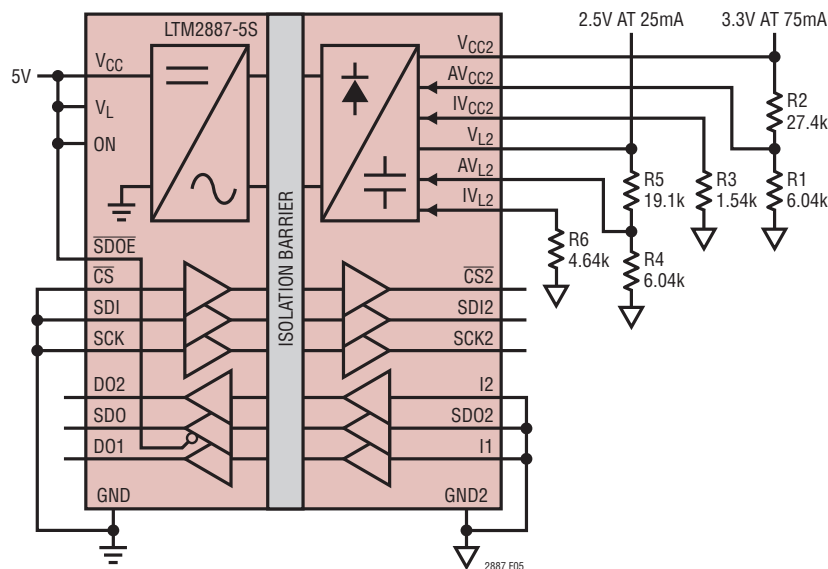

Figure 5. Adjustable Voltage Rails

APPLICATIONS INFORMATION

no jitter on the associated output channels, only delay. This preemptive scheme will produce a certain amount of uncertainty on the other isolation channels. The resulting pulse width uncertainty on these low priority channels is typically $\pm 6\text{ns}$, but may vary up to $\pm 50\text{ns}$ if the low priority channels are not encoded within the same high priority serial packet.

Serial Peripheral Interface (SPI) Bus

The LTM2887-S provides a SPI compatible isolated interface. The maximum data rate is a function of the inherent channel propagation delays, channel to channel pulse width uncertainty, and data direction requirements. Channel timing is detailed in Figures 6 through 9 and Tables 2 and 3. The SPI protocol supports four unique timing configurations defined by the clock polarity (CPOL) and clock phase (CPHA) summarized in Table 1.

Table 1. SPI Mode

CPOL	CPHA	DATA TO (CLOCK) RELATIONSHIP	
0	0	Sample (Rising)	Set-Up (Falling)
0	1	Set-Up (Rising)	Sample (Falling)
1	0	Sample (Falling)	Set-Up (Rising)
1	1	Set-Up (Falling)	Sample (Rising)

The maximum data rate for bidirectional communication is 4MHz, based on a synchronous system, as detailed in the timing waveforms. Slightly higher data rates may be achieved by skewing the clock duty cycle and minimizing the SDO to SCK set-up time, however the clock rate is still dominated by the system propagation delays. A discussion of the critical timing paths relative to Figure 6 and 7 follows.

- $\overline{\text{CS}}$ to SCK (master sample SDO, 1st SDO valid)
 - $t_0 \rightarrow t_1$ $\approx 50\text{ns}$, $\overline{\text{CS}}$ to $\overline{\text{CS2}}$ propagation delay
 - $t_1 \rightarrow t_{1+}$ Isolated slave device propagation (response time), asserts SDO2
 - $t_1 \rightarrow t_3$ $\approx 50\text{ns}$, SDO2 to SDO propagation delay
 - $t_3 \rightarrow t_5$ Set-up time for master SDO to SCK

- SDI to SCK (master data write to slave)
 - $t_2 \rightarrow t_4$ $\approx 50\text{ns}$, SDI to SDI2 propagation delay
 - $t_5 \rightarrow t_6$ $\approx 50\text{ns}$, SCK to SCK2 propagation delay
 - $t_2 \rightarrow t_5$ $\geq 50\text{ns}$, SDI to SCK, separate packet non-zero set-up time
 - $t_4 \rightarrow t_6$ $\geq 50\text{ns}$, SDI2 to SCK2, separate packet non-zero set-up time
- SDO to SCK (master sample SDO, subsequent SDO valid)
 - t_8 set-up data transition SDI and SCK
 - $t_8 \rightarrow t_{10}$ $\approx 50\text{ns}$, SDI to SDI2 and SCK to SCK2 propagation delay
 - t_{10} SDO2 data transition in response to SCK2
 - $t_{10} \rightarrow t_{11}$ $\approx 50\text{ns}$, SDO2 to SDO propagation delay
 - $t_{11} \rightarrow t_{12}$ Set-up time for master SDO to SCK

Maximum data rate for single direction communication, master to slave, is 8MHz, limited by the systems encoding/decoding scheme or propagation delay. Timing details for both variations of clock phase are shown in Figures 8 and 9 and Table 3.

Additional requirements to insure maximum data rate are:

- $\overline{\text{CS}}$ is transmitted prior to (asynchronous) or within the same (synchronous) data packet as SDI
- SDI and SCK set-up data transition occur within the same data packet. Referencing Figure 6, SDI can precede SCK by up to 13ns ($t_7 \rightarrow t_8$) or lag SCK by 3ns ($t_8 \rightarrow t_9$) and not violate this requirement. Similarly in Figure 8, SDI can precede SCK by up to 13ns ($t_4 \rightarrow t_5$) or lag SCK by 3ns ($t_5 \rightarrow t_6$).

APPLICATIONS INFORMATION

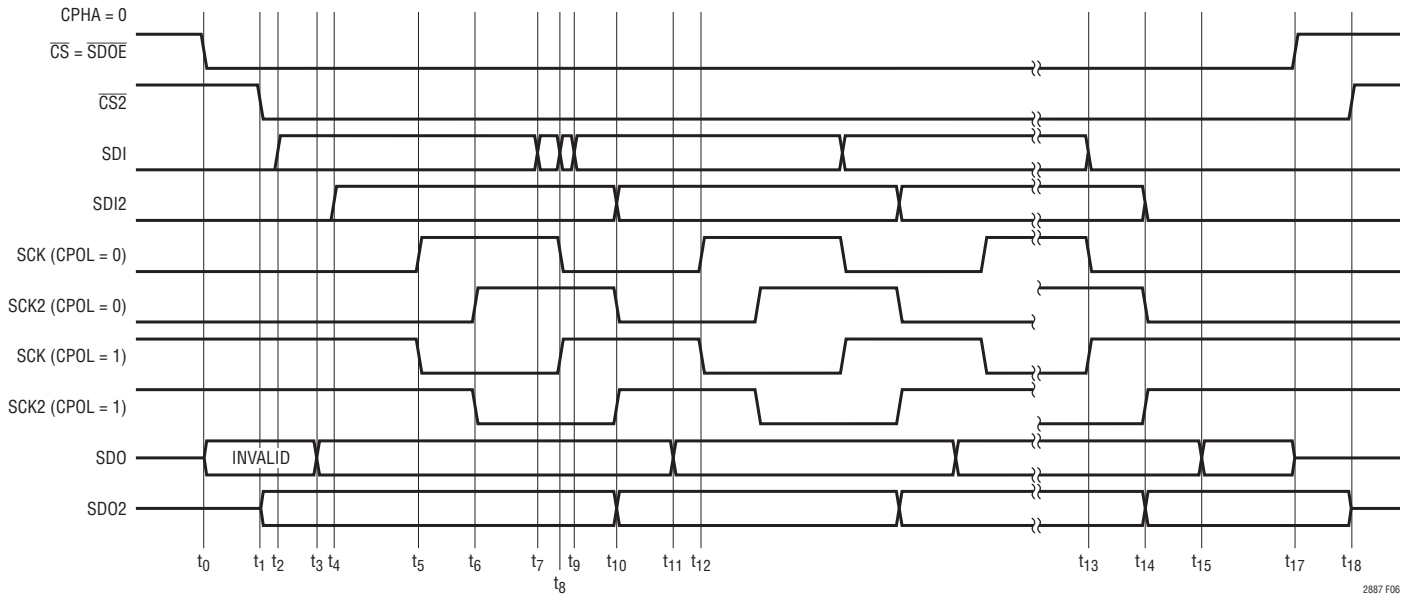

Figure 6. SPI Timing, Bidirectional, CPHA = 0

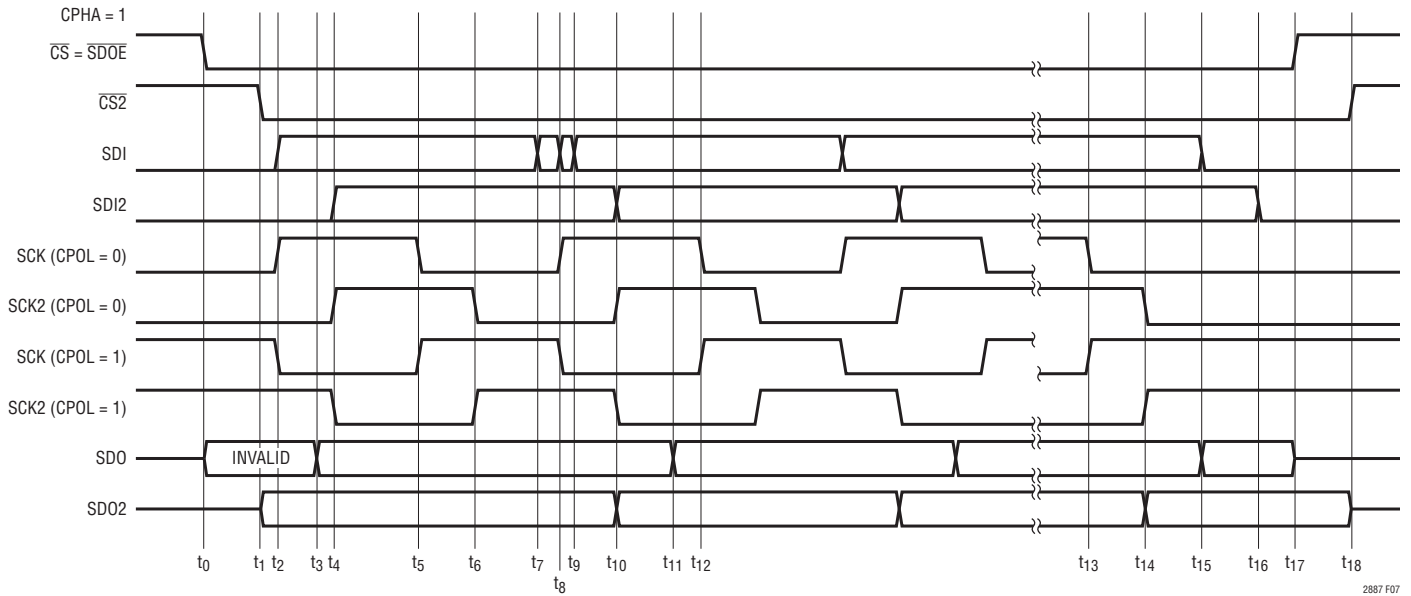

Figure 7. SPI Timing, Bidirectional, CPHA = 1

APPLICATIONS INFORMATION

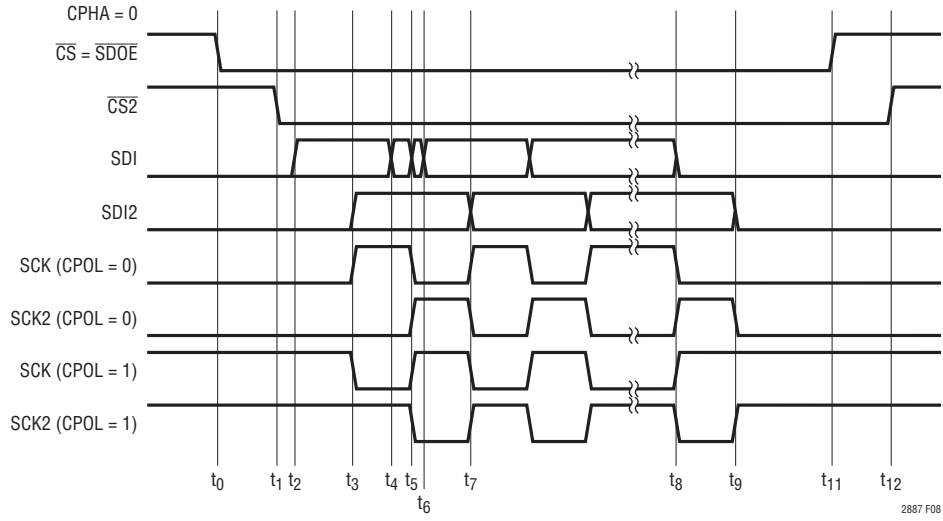

Figure 8. SPI Timing, Unidirectional, CPHA = 0

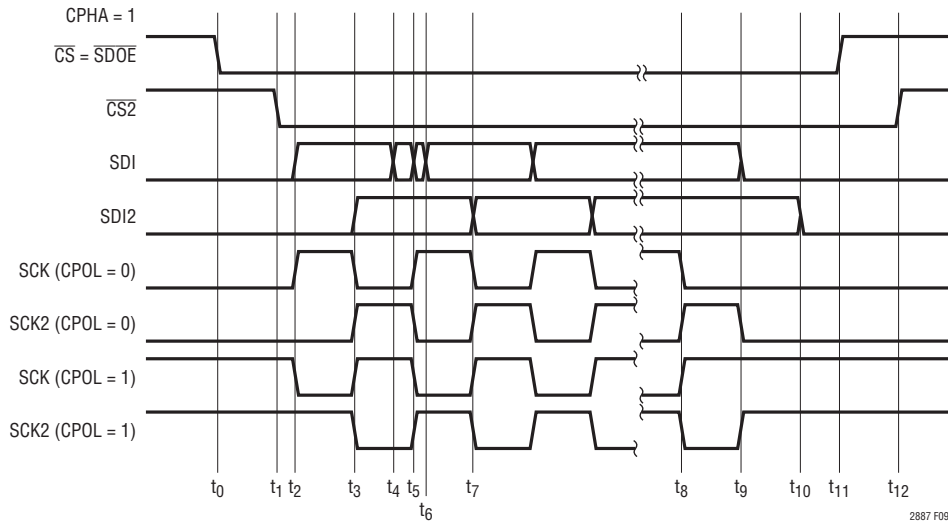

Figure 9. SPI Timing, Unidirectional, CPHA = 1

APPLICATIONS INFORMATION

Table 2. Bidirectional SPI Timing Event Description

TIME	CPHA	EVENT DESCRIPTION
t_0	0, 1	Asynchronous chip select, may be synchronous to SDI but may not lag by more than 3ns. Logic side slave data output enabled, initial data is not equivalent to slave device data output
t_0 to t_1 , t_{17} to t_{18}	0, 1	Propagation delay chip select, logic to isolated side, 50ns typical
t_1	0, 1	Slave device chip select output data enable
t_2	0	Start of data transmission, data set-up
	1	Start of transmission, data and clock set-up. Data transition must be within -13ns to 3ns of clock edge
t_1 to t_3	0, 1	Propagation delay of slave data, isolated to logic side, 50ns typical
t_3	0, 1	Slave data output valid, logic side
t_2 to t_4	0	Propagation delay of data, logic side to isolated side
	1	Propagation delay of data and clock, logic side to isolated side
t_5	0, 1	Logic side data sample time, half clock period delay from data set-up transition
t_5 to t_6	0, 1	Propagation delay of clock, logic to isolated side
t_6	0, 1	Isolated side data sample time
t_8	0, 1	Synchronous data and clock transition, logic side
t_7 to t_8	0, 1	Data to clock delay, must be $\leq 13\text{ns}$
t_8 to t_9	0, 1	Clock to data delay, must be $\leq 3\text{ns}$
t_8 to t_{10}	0, 1	Propagation delay clock and data, logic to isolated side
t_{10} , t_{14}	0, 1	Slave device data transition
t_{10} to t_{11} , t_{14} to t_{15}	0, 1	Propagation delay slave data, isolated to logic side
t_{11} to t_{12}	0, 1	Slave data output to sample clock set-up time
t_{13}	0	Last data and clock transition logic side
	1	Last sample clock transition logic side
t_{13} to t_{14}	0	Propagation delay data and clock, logic to isolated side
	1	Propagation delay clock, logic to isolated side
t_{15}	0	Last slave data output transition logic side
	1	Last slave data output and data transition, logic side
t_{15} to t_{16}	1	Propagation delay data, logic to isolated side
t_{17}	0, 1	Asynchronous chip select transition, end of transmission. Disable slave data output logic side
t_{18}	0, 1	Chip select transition isolated side, slave data output disabled

APPLICATIONS INFORMATION

Table 3. Unidirectional SPI Timing Event Description

TIME	CPHA	EVENT DESCRIPTION
t_0	0, 1	Asynchronous chip select, may be synchronous to SDI but may not lag by more than 3ns
t_0 to t_1	0, 1	Propagation delay chip select, logic to isolated side
t_2	0	Start of data transmission, data set-up
	1	Start of transmission, data and clock set-up. Data transition must be within -13ns to 3ns of clock edge
t_2 to t_3	0	Propagation delay of data, logic side to isolated side
	1	Propagation delay of data and clock, logic side to isolated side
t_3	0, 1	Logic side data sample time, half clock period delay from data set-up transition
t_3 to t_5	0, 1	Clock propagation delay, clock and data transition
t_4 to t_5	0, 1	Data to clock delay, must be $\leq 13\text{ns}$
t_5 to t_6	0, 1	Clock to data delay, must be $\leq 3\text{ns}$
t_5 to t_7	0, 1	Data and clock propagation delay
t_8	0	Last clock and data transition
	1	Last clock transition
t_8 to t_9	0	Clock and data propagation delay
	1	Clock propagation delay
t_9 to t_{10}	1	Data propagation delay
t_{11}	0, 1	Asynchronous chip select transition, end of transmission
t_{12}	0, 1	Chip select transition isolated side

Inter-IC Communication (I²C) Bus

The LTM2887-I provides an I²C compatible isolated interface. Clock (SCL) is unidirectional, supporting master mode only, and data (SDA) is bidirectional. The maximum data rate is 400kHz which supports fast-mode I²C. Timing is detailed in Figure 10. The data rate is limited by the slave acknowledge setup time ($t_{\text{SU;ACK}}$), consisting of the I²C

standard minimum setup time ($t_{\text{SU;DAT}}$) of 100ns, maximum clock propagation delay of 225ns, glitch filter and isolated data delay of 500ns maximum, and the combined isolated and logic data fall time of 300ns at maximum bus loading. The total setup time reduces the I²C data hold time ($t_{\text{HD;DAT}}$) to a maximum of 175ns, guaranteeing sufficient data setup time ($t_{\text{SU;ACK}}$).

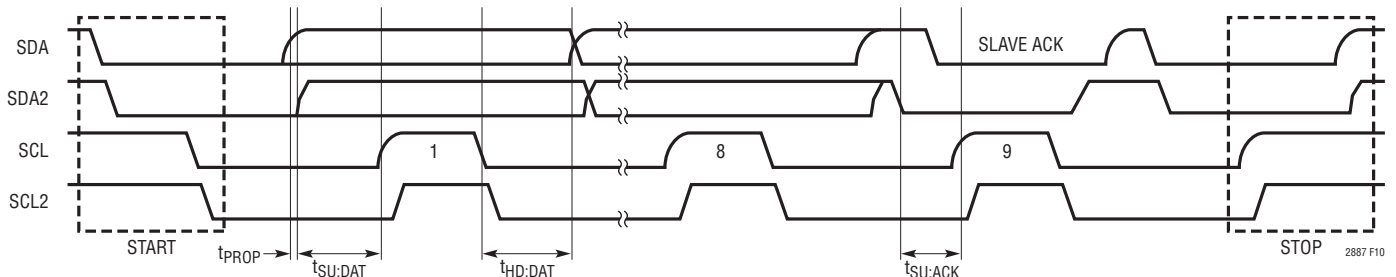
Figure 10. I²C Timing Diagram

APPLICATIONS INFORMATION

The isolated side bidirectional serial data pin, SDA2, simplified schematic is shown in Figure 11. An internal 1.8mA current source provides a pull-up for SDA2. Do not connect any other pull-up device to SDA2. This current source is sufficient to satisfy the system requirements for bus capacitances greater than 200pF in FAST mode and greater than 400pF in STANDARD mode.

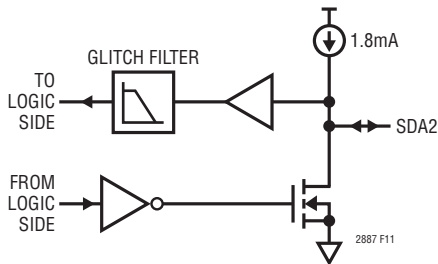

Figure 11. Isolated SDA2 Pin Schematic

Additional proprietary circuitry monitors the slew rate on the SDA and SDA2 signals to manage directional control across the isolation barrier. Slew rates on both pins must be greater than $1\text{V}/\mu\text{s}$ for proper operation.

The logic side bidirectional serial data pin, SDA, requires a pull-up resistor or current source connected to V_L . Follow the requirements in Figures 12 and 13 for the appropriate pull-up resistor on SDA that satisfies the desired rise time specifications and V_{OL} maximum limits for FAST and STANDARD modes. The resistance curves represent the maximum resistance boundary; any value may be used to the left of the appropriate curve.

The isolated side clock pin, SCL2, has a weak push-pull output driver; do not connect an external pull-up device. SCL2 is compatible with I²C devices without clock stretching. On lightly loaded connections, a 100pF capacitor from SCL2 to GND2 or RC lowpass filter ($R = 500\Omega$, $C = 100\text{pF}$) can be used to increase the rise and fall times and minimize noise.

Some consideration must be given to signal coupling between SCL2 and SDA2. Separate these signals on a printed circuit board or route with ground between. If these signals are wired off board, twist SCL2 with V_{CC2} and/or GND2 and SDA2 with GND2 and/or V_{CC2} , do not twist SCL2 and SDA2 together. If coupling between SCL2 and SDA2 is unavoidable, place the aforementioned RC filter at the SCL2 pin to reduce noise injection onto SDA2.

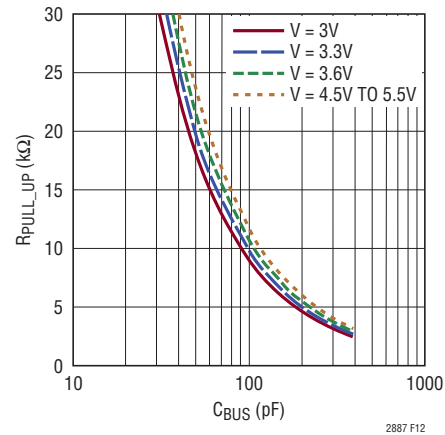

Figure 12. Maximum Standard Speed Pull-Up Resistance on SDA

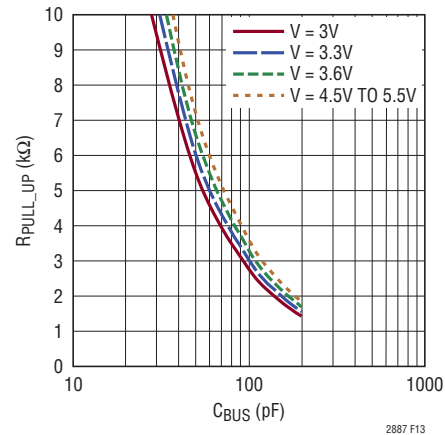

Figure 13. Maximum Fast Speed Pull-Up Resistance on SDA

APPLICATIONS INFORMATION

RF, Magnetic Field Immunity

The isolator μ Module technology used within the LTM2887 has been independently evaluated, and successfully passed the RF and magnetic field immunity testing requirements per European Standard EN 55024, in accordance with the following test standards:

EN 61000-4-3	Radiated, Radio-Frequency, Electromagnetic Field Immunity
EN 61000-4-8	Power Frequency Magnetic Field Immunity
EN 61000-4-9	Pulsed Magnetic Field Immunity

Tests were performed using an unshielded test card designed per the data sheet PCB layout recommendations. Specific limits per test are detailed in Table 4.

Table 4. EMC Immunity Tests

TEST	FREQUENCY	FIELD STRENGTH
EN 61000-4-3 Annex D	80MHz to 1GHz	10V/m
	1.4MHz to 2GHz	3V/m
	2GHz to 2.7GHz	1V/m
EN 61000-4-8 Level 4	50Hz and 60Hz	30A/m
EN 61000-4-8 Level 5	60Hz	100A/m*
EN 61000-4-9 Level 5	Pulse	1000A/m

*non IEC method

PCB Layout

The high integration of the LTM2887 makes PCB layout very simple. However, to optimize its electrical isolation characteristics, EMI, and thermal performance, some layout considerations are necessary.

- Under heavily loaded conditions V_{CC} and GND current can exceed 300mA. Sufficient copper must be used on the PCB to insure resistive losses do not cause the supply voltage to drop below the minimum allowed level. Similarly, the V_{CC2} and GND2 conductors must be sized to support any external load current. These heavy copper traces will also help to reduce thermal stress and improve the thermal conductivity.

- Input and output decoupling is not required, since these components are integrated within the package. An additional bulk capacitor with a value of 6.8 μ F to 22 μ F is recommended. The high ESR of this capacitor reduces board resonances and minimizes voltage spikes caused by hot plugging of the supply voltage. For EMI sensitive applications, an additional low ESL ceramic capacitor of 1 μ F to 4.7 μ F, placed as close to the power and ground terminals as possible, is recommended. Alternatively, a number of smaller value parallel capacitors may be used to reduce ESL and achieve the same net capacitance.
- Do not place copper on the PCB between the inner columns of pads. This area must remain open to withstand the rated isolation voltage.
- The use of solid ground planes for GND and GND2 is recommended for non-EMI critical applications to optimize signal fidelity, thermal performance, and to minimize RF emissions due to uncoupled PCB trace conduction. The drawback of using ground planes, where EMI is of concern, is the creation of a dipole antenna structure which can radiate differential voltages formed between GND and GND2. If ground planes are used it is recommended to minimize their area, and use contiguous planes as any openings or splits can exacerbate RF emissions.
- For large ground planes a small capacitance (≤ 330 pF) from GND to GND2, either discrete or embedded within the substrate, provides a low impedance current return path for the module parasitic capacitance, minimizing any high frequency differential voltages and substantially reducing radiated emissions. Discrete capacitance will not be as effective due to parasitic ESL. In addition, voltage rating, leakage, and clearance must be considered for component selection. Embedding the capacitance within the PCB substrate provides a near ideal capacitor and eliminates component selection issues; however, the PCB must be 4 layers. Care must be exercised in applying either technique to ensure the voltage rating of the barrier is not compromised.

APPLICATIONS INFORMATION

- In applications without an embedded PCB substrate capacitance a slot may be added between the logic side and isolated side device pins. The slot extends the creepage path between terminals on the PCB side, and may reduce leakage caused by PCB contamination. The slot should be placed in the middle of the device and extend beyond the package perimeter.

The PCB layout in Figures 14 and 15 shows the low EMI demo board for the LTM2887. The demo board uses a combination of EMI mitigation techniques, including both embedded PCB bridge capacitance and discrete GND to GND2 capacitors. Two safety rated type Y2 capacitors are used in series, manufactured by MuRata, part number GA342QR7GF471KW01L. The embedded capacitor effectively suppresses emissions above 400MHz, whereas the discrete capacitors are more effective below 400MHz. EMI performance is shown in Figure 16, measured using a Gigahertz Transverse Electromagnetic (GTEM) cell and method detailed in IEC 61000-4-20, Testing and Measurement Techniques – Emission and Immunity Testing in Transverse Electromagnetic Waveguides.

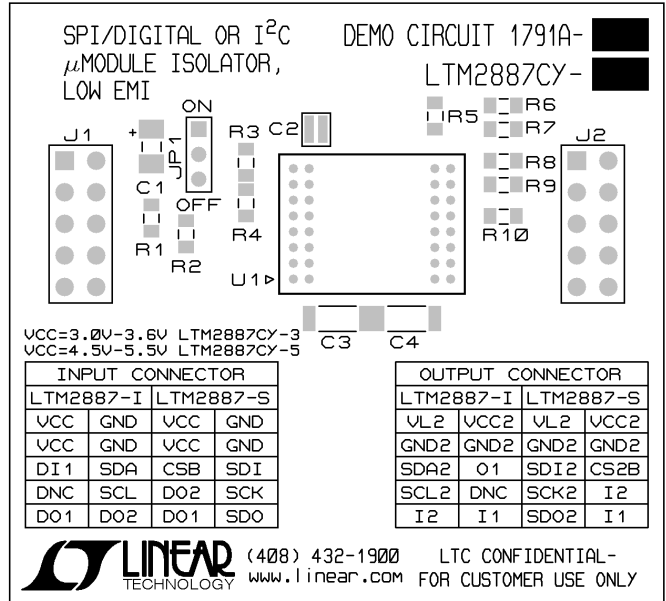
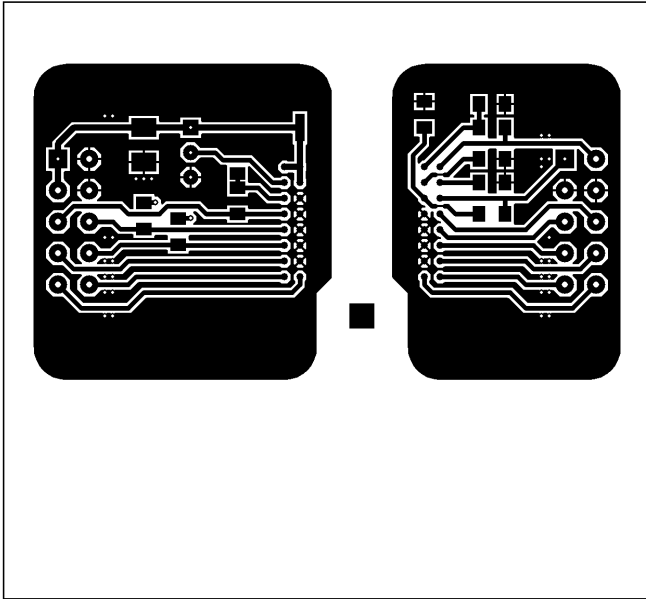

Figure 14. LTM2887 Low EMI Demo Board Layout

APPLICATIONS INFORMATION

Top Layer



Inner Layer 2

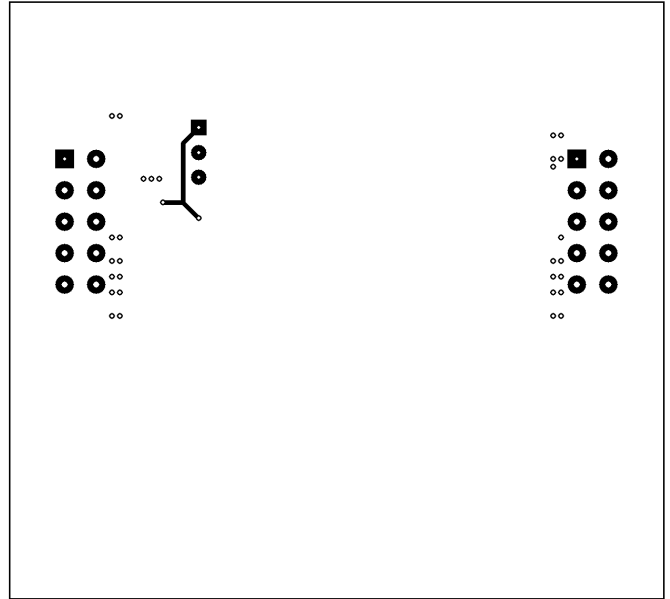

Inner Layer 1

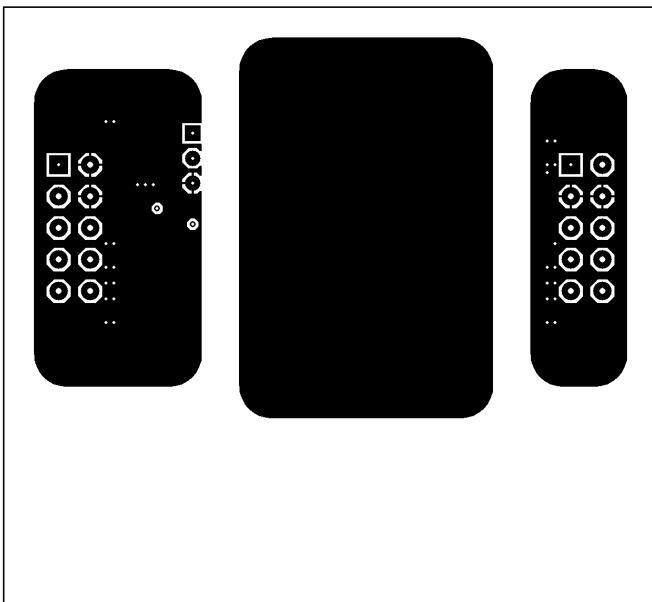

Bottom Layer

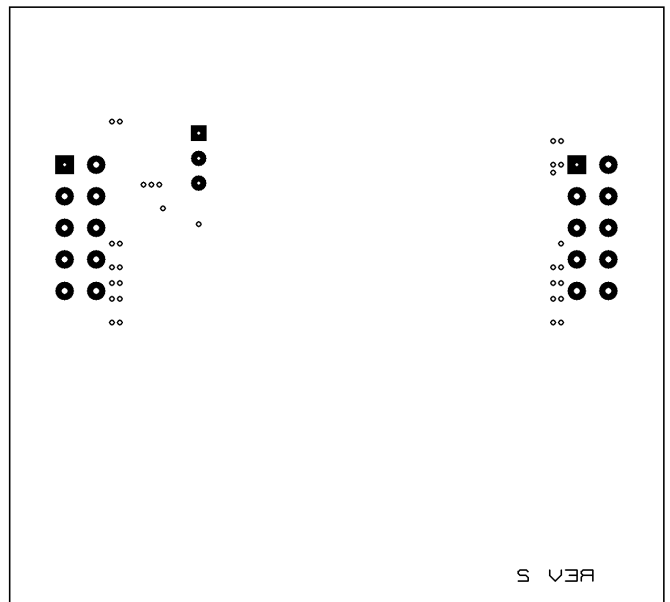

Figure 15. LTM2887 Low EMI Demo Board Layout (DC1791A)

APPLICATIONS INFORMATION

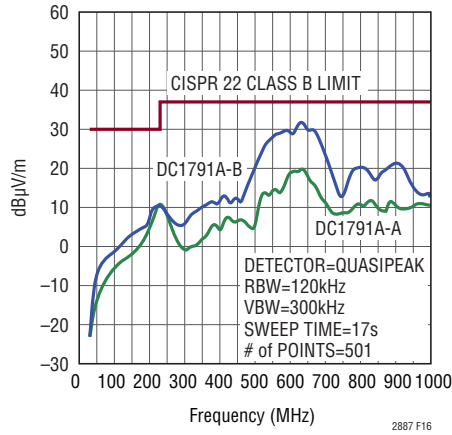

Figure 16. LTM2887 Low EMI Demo Board Emissions

TYPICAL APPLICATIONS

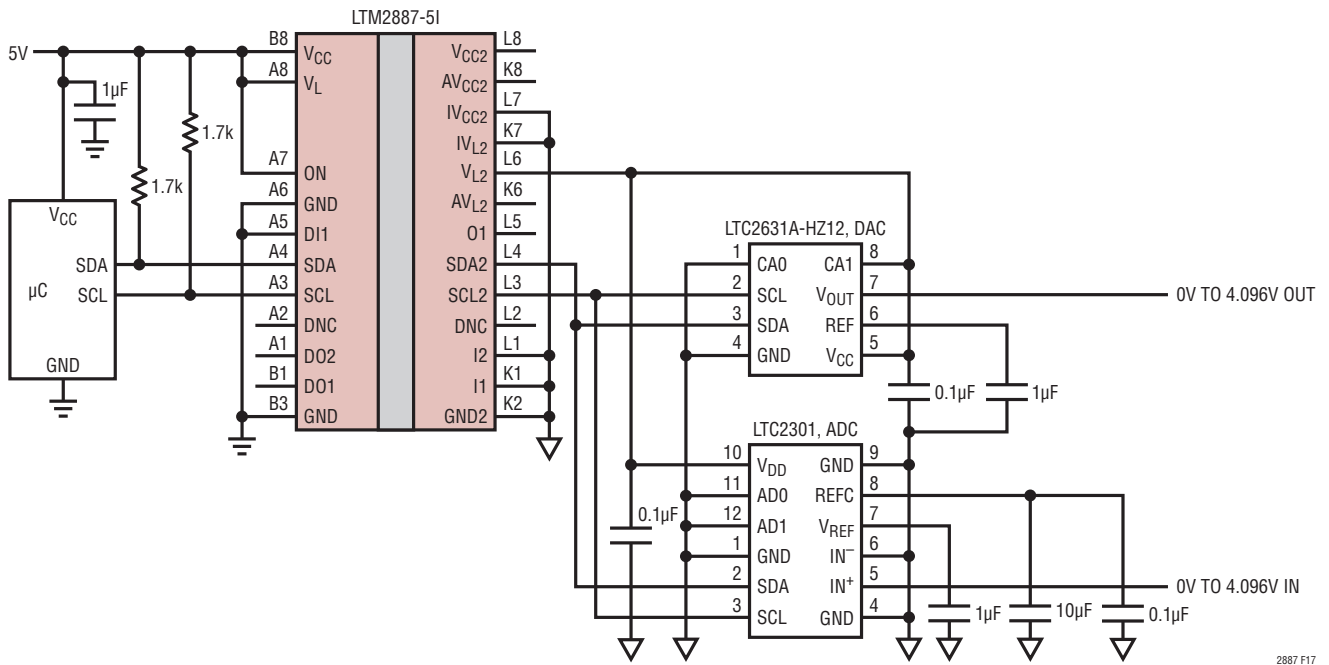

Figure 17. Isolated I²C 12-Bit, 0V to 4.096V Analog Input and Output

TYPICAL APPLICATIONS

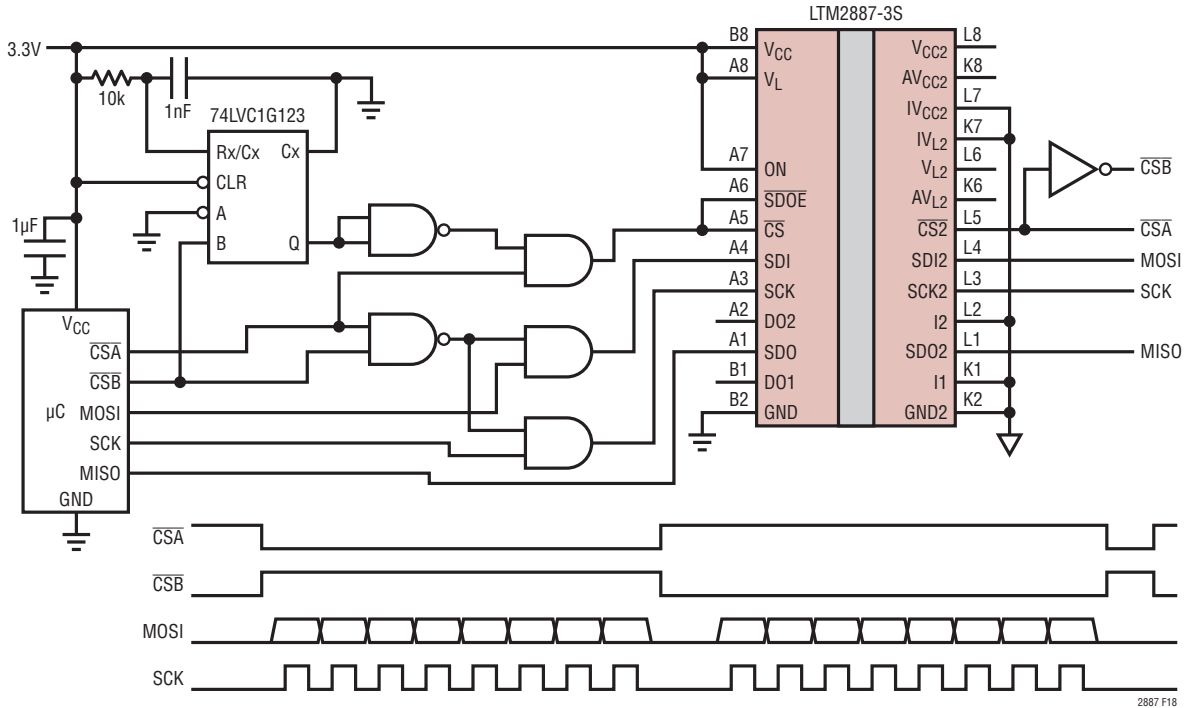

Figure 18. Isolated SPI Device Expansion

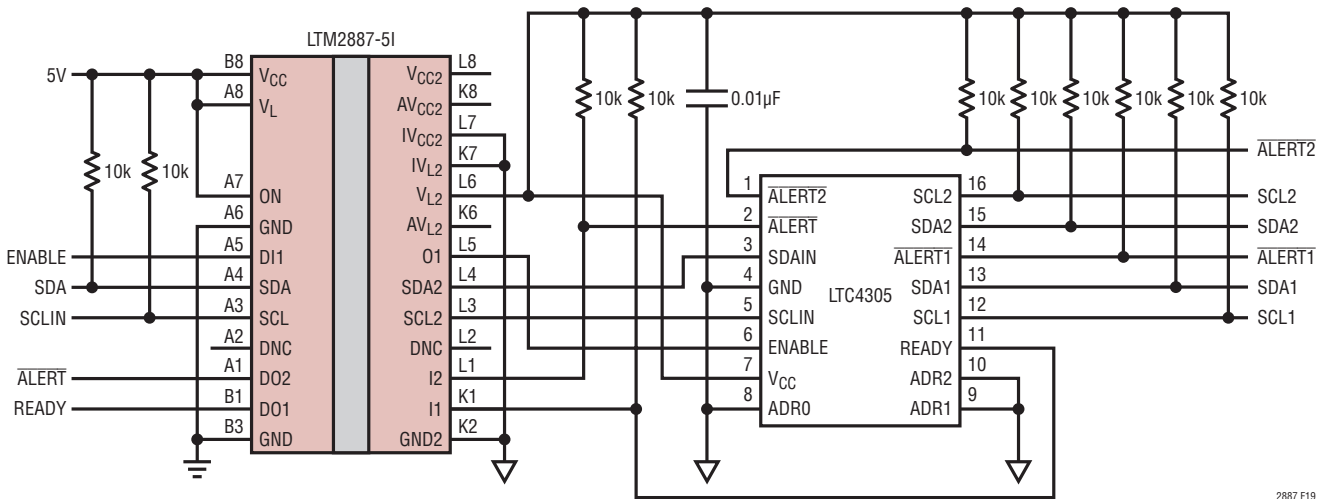

Figure 19. Isolated I²C Buffer with Dual Outputs

TYPICAL APPLICATIONS

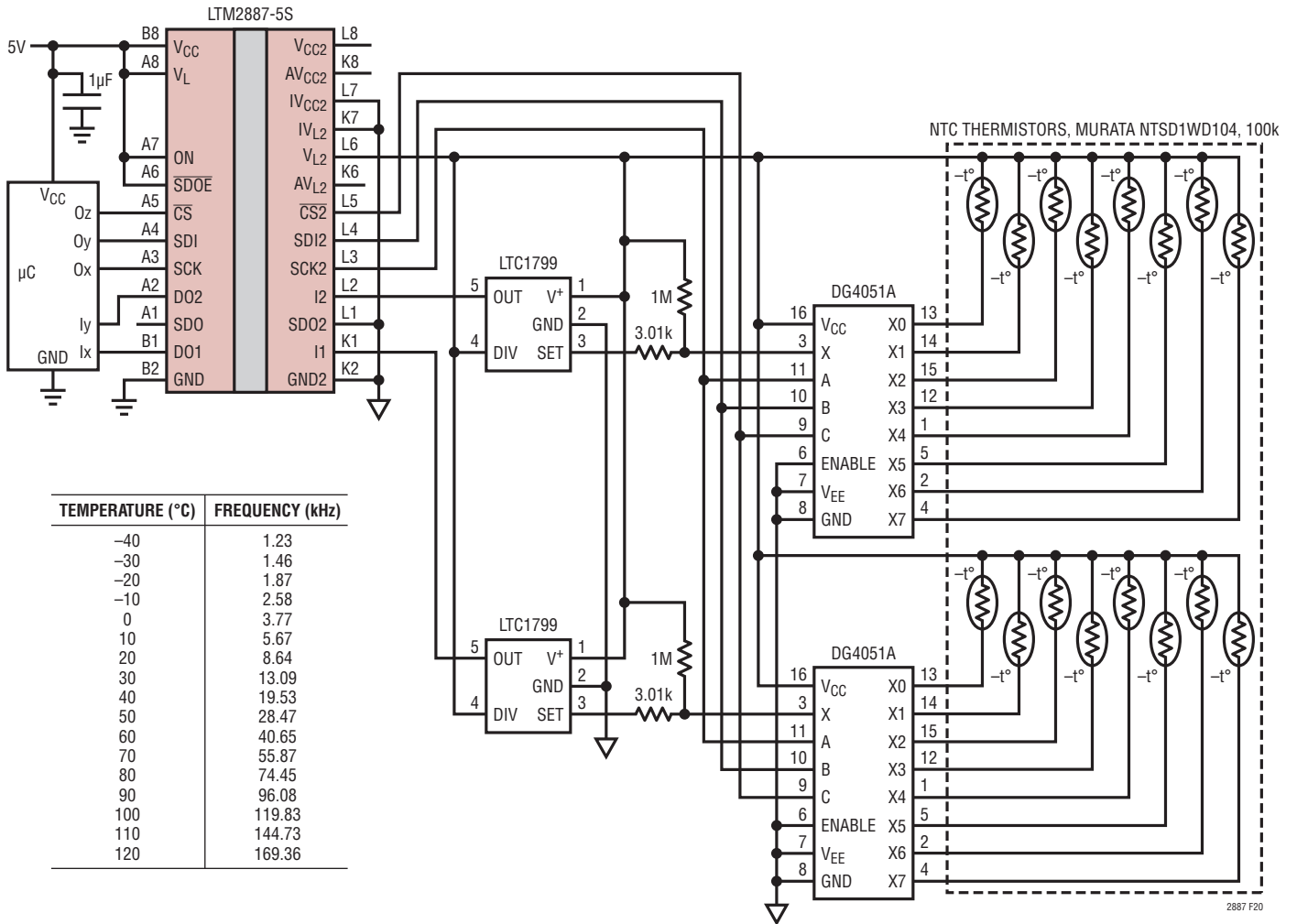

Figure 20. 16-Channel Isolated Temperature to Frequency Converter

TYPICAL APPLICATIONS

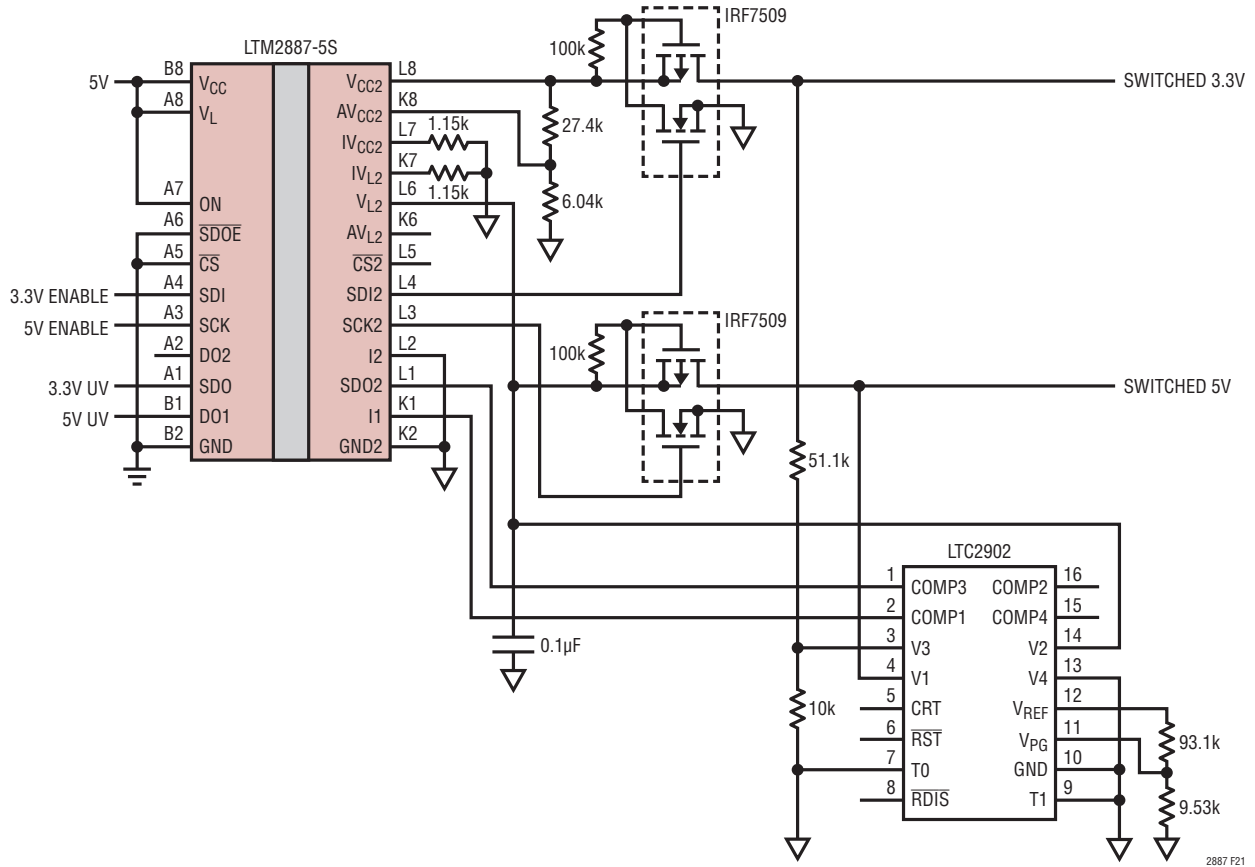
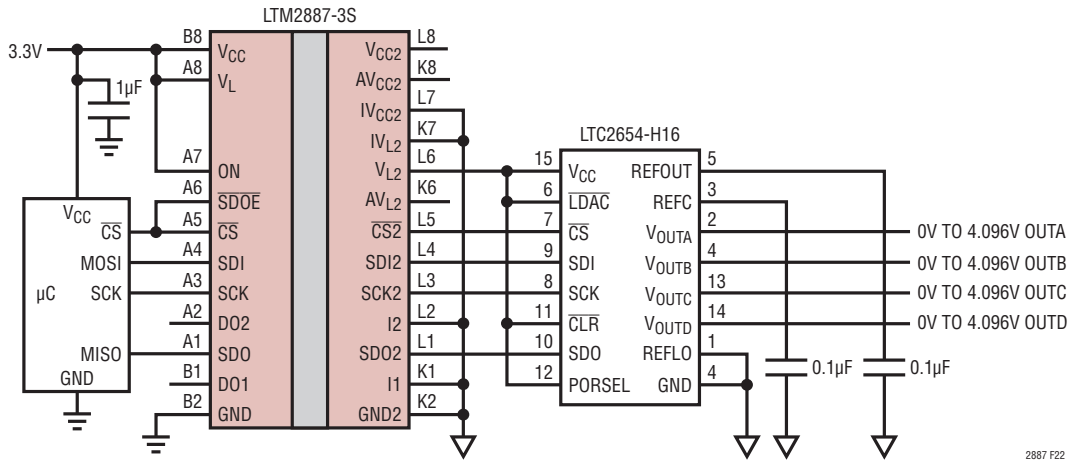

Figure 21. Digitally Switched Dual Power Supply with Undervoltage Monitor

2887 F21

TYPICAL APPLICATIONS



2887 F22

Figure 22. Quad 16-Bit 0 to 4.096V Output Range DAC

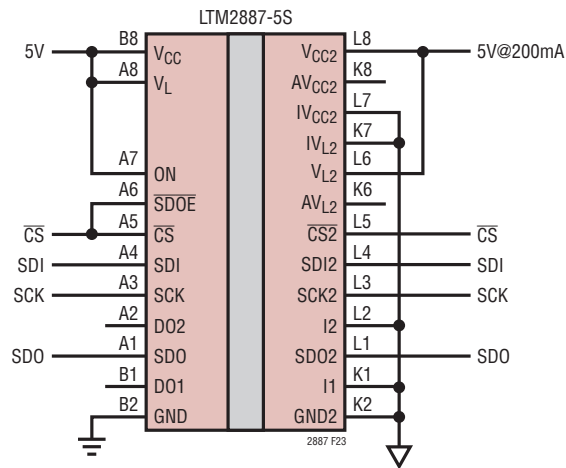

2887 F23

Figure 23. Parallel Output Supplies for Higher Current

TYPICAL APPLICATIONS

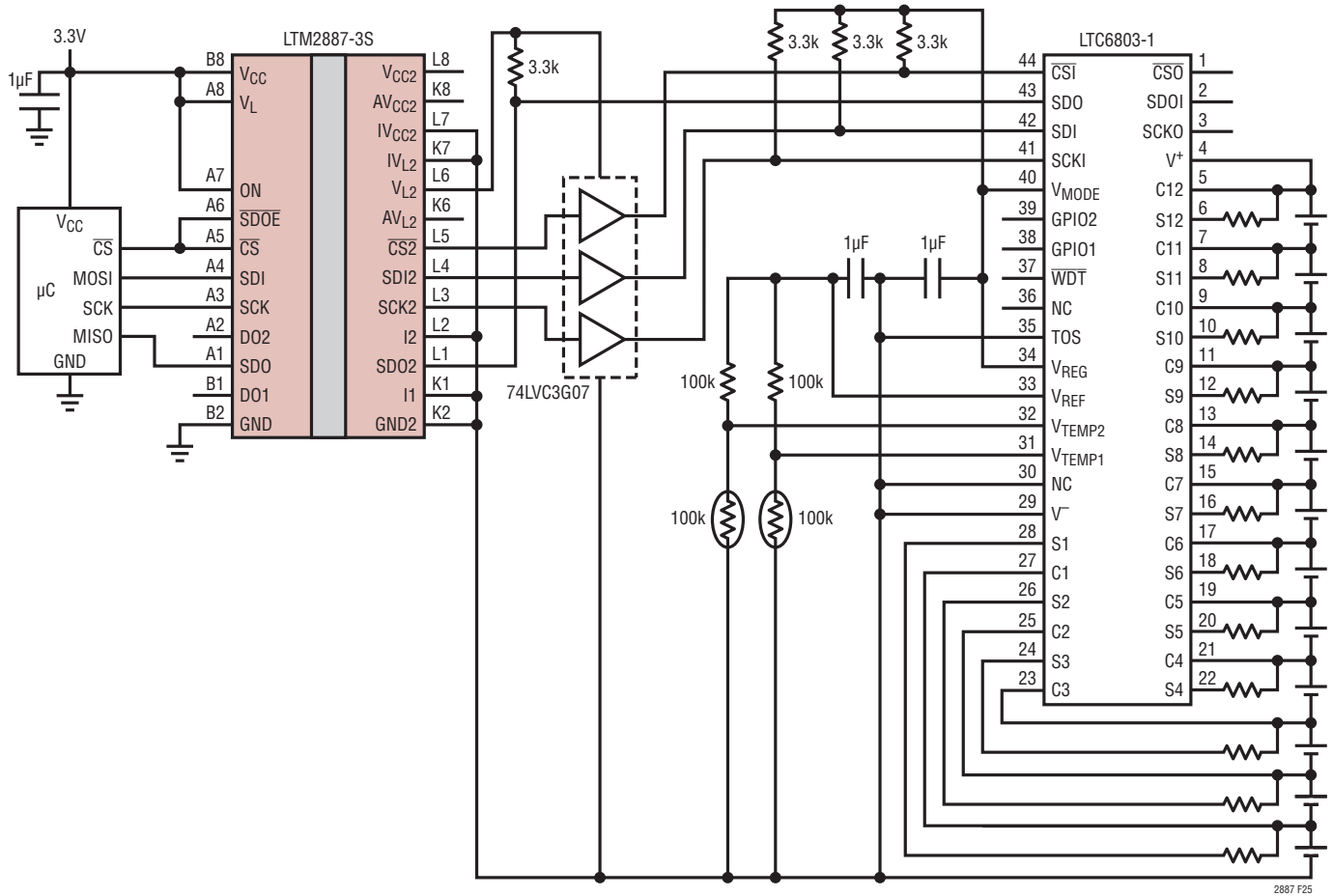

Figure 25. 12-Cell Battery Stack Monitor with Isolated SPI Interface and Low Power Shutdown

TYPICAL APPLICATIONS

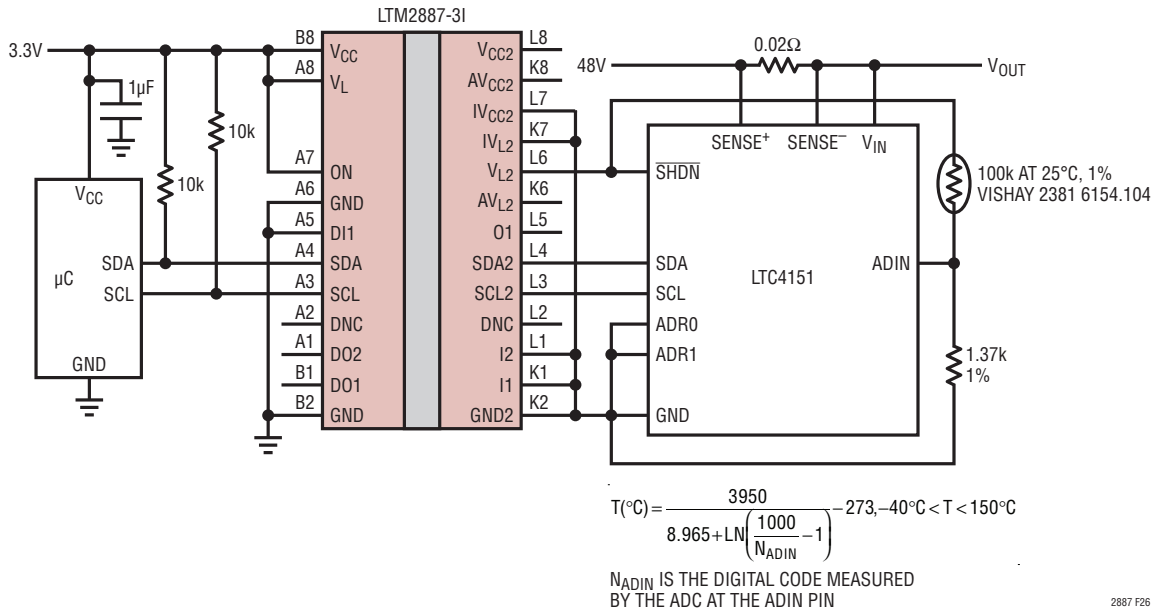

Figure 26. Isolated I²C Voltage, Current and Temperature Power Supply Monitor

2887 F26

TYPICAL APPLICATIONS

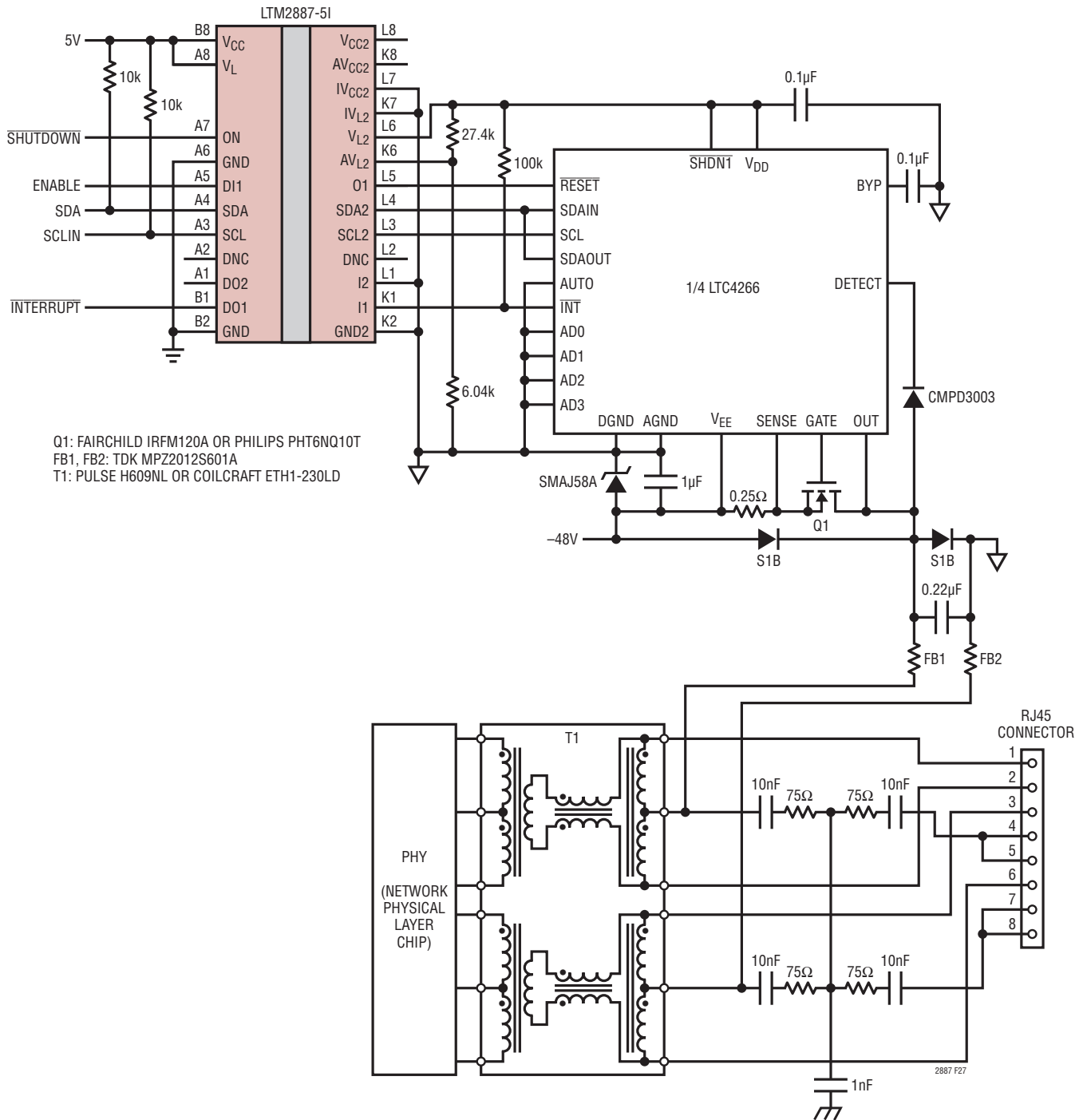
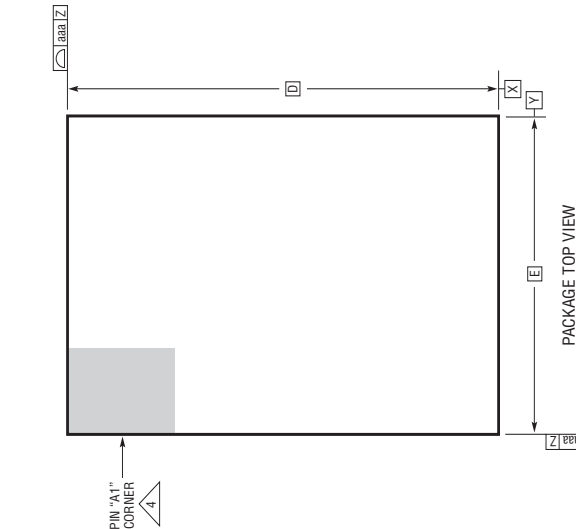
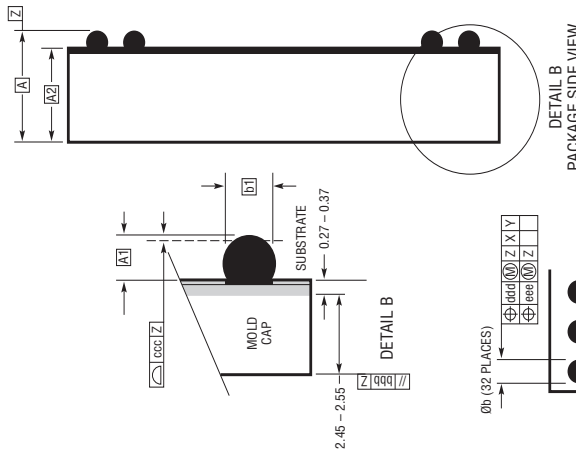
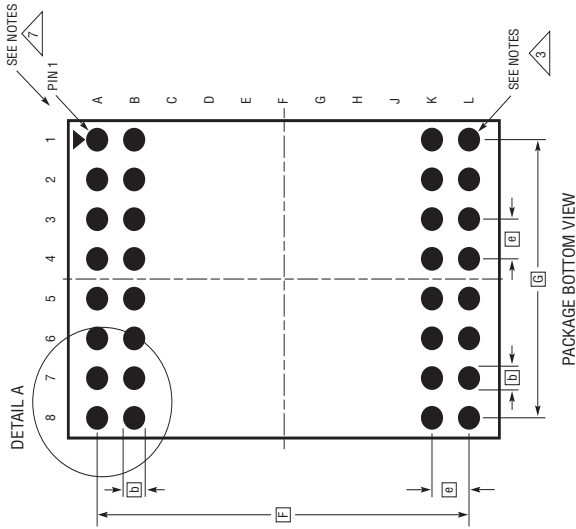

Figure 27. One Complete Isolated Powered Ethernet Port

PACKAGE DESCRIPTION

Please refer to <http://www.linear.com/product/LTM2887#packaging> for the most recent package drawings.

BGA Package
32-Lead (15mm × 11.25mm × 3.42mm)
 (Reference LTC DWG # 05-08-1851 Rev D)



- NOTES:
- DIMENSIONING AND TOLERANCING PER ASME Y14.5M-1994
 - ALL DIMENSIONS ARE IN MILLIMETERS
 - BALL DESIGNATION PER JEDEC MS-028 AND JEP95
 - DETAILS OF PIN #1 IDENTIFIER ARE OPTIONAL, BUT MUST BE LOCATED WITHIN THE ZONE INDICATED. THE PIN #1 IDENTIFIER MAY BE EITHER A MOLD OR MARKED FEATURE
 - PRIMARY DATUM -Z- IS SEATING PLANE
 - SOLDER BALL COMPOSITION IS 96.5% Sn/3.0% Ag/0.5% Cu
 - PACKAGE ROW AND COLUMN LABELING MAY VARY AMONG μ MODULE PRODUCTS. REVIEW EACH PACKAGE LAYOUT CAREFULLY

SYMBOL	DIMENSIONS		NOTES
	MIN	MAX	
A	3.22	3.62	
A1	0.50	0.70	
A2	2.72	2.92	
b	0.60	0.90	
b1	0.60	0.63	
D	15.0		
E	11.25		
F	12.70		
G	8.89		
aaa		0.15	
bbb		0.10	
ccc		0.20	
ddd		0.30	
eee		0.15	
TOTAL NUMBER OF BALLS: 32			

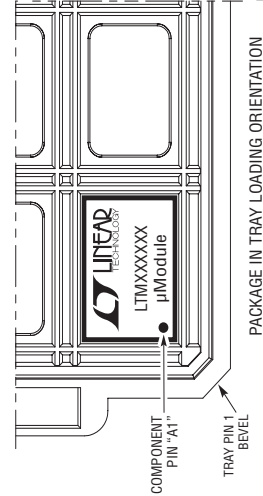
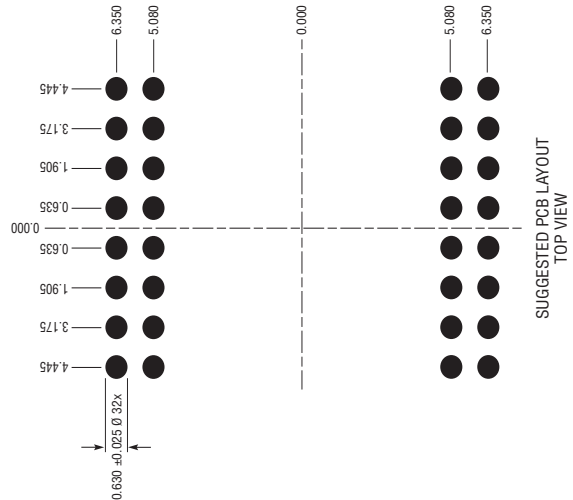

BGA.32.1112 REV D

REVISION HISTORY

REV	DATE	DESCRIPTION	PAGE NUMBER
A	03/17	Added UL-CSA File Number	1
B	07/17	Changed MIN limit for t_{PWU} (SPI and I ² C)	6

TYPICAL APPLICATION

Isolated Dual Channel Simultaneous Sampling Analog to Digital Converter, Input Range 0V to 2.5V

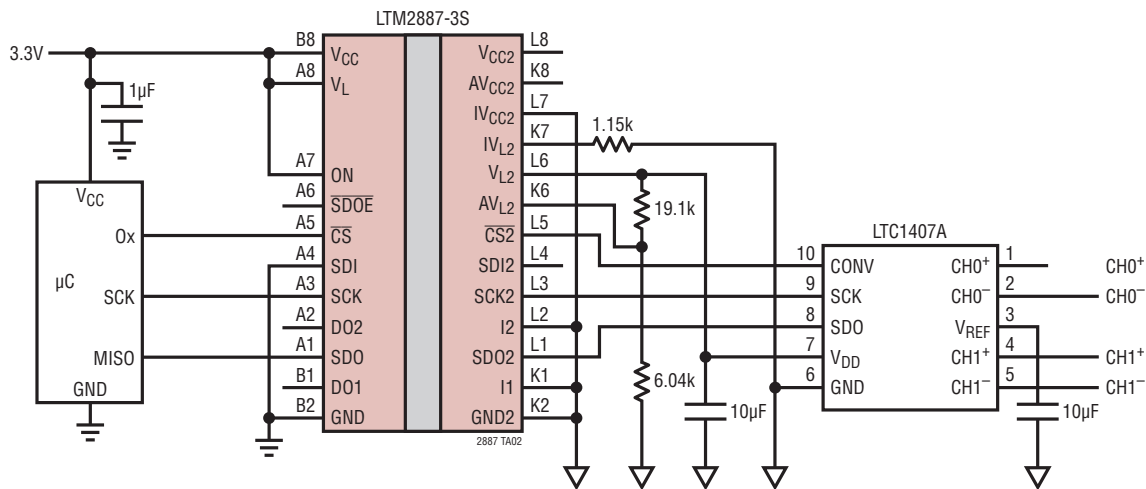

RELATED PARTS

PART NUMBER	DESCRIPTION	COMMENTS
LTM2881	Isolated RS485/RS422 µModule Transceiver with Integrated DC/DC Converter	20Mbps 2500V _{RMS} Isolation with Power in LGA/BGA Package
LTM2882	Dual Isolated RS232 µModule Transceiver with Integrated DC/DC Converter	2500V _{RMS} Isolation with Power in LGA/BGA Package
LTM2883	SPI/Digital or I ² C µModule Isolator with Integrated DC/DC Converter	2500V _{RMS} Isolation with Adjustable ±12.5V and 5V Power in BGA Package
LTM2884	Isolated USB Transceiver with Power	2500V _{RMS} Auto Speed Selection, 1 to 2.5W Isolated Power
LTM2886	SPI/Digital or I ² C µModule Isolator with Integrated DC/DC Converter	2500V _{RMS} Isolation with Fixed ±5V and Adjustable 5V Power in BGA Package
LTM2889	Isolated CAN FD µModule Transceiver with Power	4Mbps 2500V _{RMS} Isolation with Power in BGA Package
LTM2892	SPI/Digital or I ² C µModule Isolator	3500V _{RMS} Isolation without Power in 9mm × 6.25mm BGA Package
LTC®1535	Isolated RS485 Transceiver	2500V _{RMS} Isolation with External Transformer Drive
LTC4310	Hot-Swappable I ² C Isolators	Bidirectional I ² C Communication, Low Voltage Level Shifting, 100kHz or 400kHz Operation
LTC6803-1, LTC6803-3, LTC6803-2, LTC6803-4	Multicell Battery Stack Monitor	LTC6803-1 Allows for Multiple Devices to be Daisy Chained, the LTC6803-2 Allows for Parallel Communication Battery Stack Topologies

Looking for pricing, stock, or lifecycle information?

Click below to explore more details on WIN SOURCE:

 [View LTM2887CY-5S#PBF on WIN SOURCE](#)

 [Linear Technology](#) Information

Optimize Your Supply Chain with WIN SOURCE Solutions

-  Global Sourcing Solution
-  Obsolete Management
-  Cost Control Management
-  Shortage Management
-  Alternative Solution
-  Excess Inventory Management