



**THE DATASHEET OF
TPS53317ARGBT**



TPS53317A 6-A Output, D-CAP+ Mode, Synchronous Step-Down, Integrated-FET Converter for DDR Memory Termination

1 Features

- TI-Proprietary Integrated MOSFET and Packaging Technology
- Supports DDR Memory Termination with up to 6-A Continuous Output Source or Sink Current
- External Tracking
- Minimum External Components Count
- 0.9-V to 6-V Conversion Voltage
- D-CAP+™ Mode Architecture
- Supports All MLCC Output Capacitors and SP/POSCAP
- Selectable SKIP Mode or Forced CCM
- Optimized Efficiency at Light and Heavy Loads
- Selectable 600-kHz or 1-MHz Switching Frequency
- Selectable Overcurrent Limit (OCL)
- Overvoltage, Over-Temperature and Hiccup Undervoltage Protection
- Adjustable Output Voltage from 0.45 V to 2 V
- 3.5 mm × 4 mm, 20-Pin, VQFN Package

2 Applications

- Memory Termination Regulator for DDR, DDR2, DDR3, DDR3L, and DDR4
- VTT Termination
- Low-Voltage Applications for 0.9-V to 6-V Input Rails

3 Description

The TPS53317A device is a FET-integrated synchronous buck regulator designed mainly for DDR termination. It can provide a regulated output at $\frac{1}{2} V_{DDQ}$ with both sink and source capability. The TPS53317A device employs D-CAP+ mode operation that provides ease of use, low external component count and fast transient response. The device can also be used for other point-of-load (POL) regulation applications requiring up to 6 A. In addition, the device supports full, 6-A, output sinking current capability with tight voltage regulation.

The device features two switching frequency settings (600 kHz and 1 MHz), integrated droop support, external tracking capability, pre-bias startup, output soft discharge, integrated bootstrap switch, power good function, V5IN pin UVLO protection, and supports both ceramic and SP/POSCAP capacitors. It supports input voltages up to 6.0 V, and output voltages adjustable from 0.45 V to 2.0 V.

The TPS53317A device is available in the 3.5 mm × 4 mm, 20-pin, VQFN package (Green RoHs compliant and Pb free) with TI proprietary Integrated MOSFET and packaging technology and is specified from -40°C to 85°C .

Device Information⁽¹⁾

PART NUMBER	PACKAGE	BODY SIZE (NOM)
TPS53317A	VQFN (20)	3.50 mm × 4.00 mm

(1) For all available packages, see the orderable addendum at the end of the data sheet.

Simplified Application

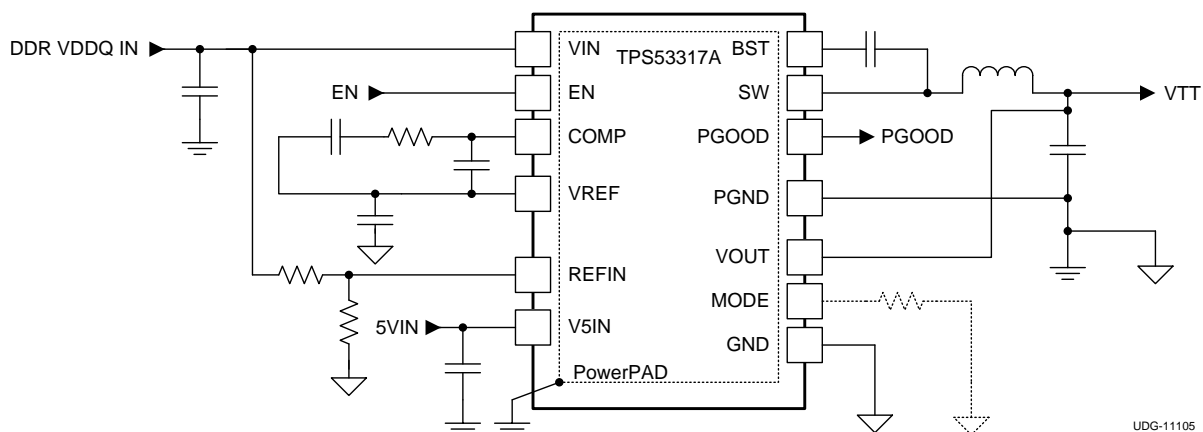

UDG-11105



Table of Contents

1 Features 1 2 Applications 1 3 Description 1 4 Revision History 2 5 Pin Configuration and Functions 3 6 Specifications 4 6.1 Absolute Maximum Ratings 4 6.2 ESD Ratings..... 4 6.3 Recommended Operating Conditions 4 6.4 Thermal Information 5 6.5 Electrical Characteristics..... 5 6.6 Typical Characteristics 7 7 Detailed Description 10 7.1 Overview 10 7.2 Functional Block Diagram 10 7.3 Feature Description..... 11	7.4 Device Functional Modes..... 15 8 Application and Implementation 19 8.1 Application Information..... 19 8.2 Typical Applications 19 9 Power Supply Recommendations 25 10 Layout 25 10.1 Layout Guidelines 25 10.2 Layout Example 25 10.3 Mounting and Thermal Profile Recommendation.. 26 11 Device and Documentation Support 27 11.1 Community Resources..... 27 11.2 Trademarks 27 11.3 Electrostatic Discharge Caution..... 27 11.4 Glossary 27 12 Mechanical, Packaging, and Orderable Information 27
--	--

4 Revision History

Changes from Original (November 2015) to Revision A	Page
<ul style="list-style-type: none"> • Updated document status from <i>Product Preview</i> to <i>Production Data</i>. 1 	1

5 Pin Configuration and Functions

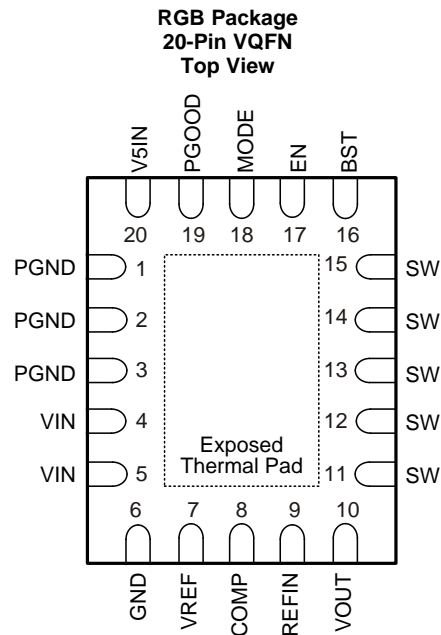

Pin Functions

PIN		I/O ⁽¹⁾	DESCRIPTION
NAME	NO.		
BST	16	I	Power supply for internal high-side gate driver. Connect a 0.1- μ F bootstrap capacitor between this pin and the SW pin. Include a series boot resistor when the voltage spike on switching node is above 7 V.
COMP	8	O	Connect an R-C-C network between this pin and VREF for loop compensation.
EN	17	I	Enable pin (3.3-V logic compatible).
GND	6	–	Analog ground.
MODE	18	I	Allows selection of different operation modes. (See Table 1)
PGND	1	G	Power ground.
	2		
	3		
PGOOD	19	O	Open drain power good output. Connect pullup resistor.
REFIN	9	I	External tracking reference input. Apply voltage between 0.45 V to 2.0 V. For non-tracking mode, connect REFIN to VREF via resistor divider.
SW	11	I/O	Switching node output.
	12		
	13		
	14		
	15		
V5IN	20	I	5-V power supply for analog circuits and gate drive.
VIN	4	I	Power supply input pin.
	5		
VOUT	10	I	Output voltage monitor input pin.
VREF	7	O	2.0-V reference output. Connect a ceramic capacitor with a value of 0.22- μ F or greater between this pin and GND.

(1) I = Input, O = Output, G = Ground

6 Specifications

6.1 Absolute Maximum Ratings

over operating free-air temperature range (unless otherwise noted) ⁽¹⁾

		MIN	MAX	UNIT
Input voltage range	BST (with respect to SW), V5IN, VIN	-0.3	7	V
	BST	-0.3	14	
	EN	-0.3	7	
	MODE, REFIN	-0.3	3.6	
	VOUT	-1	3.6	
Output voltage range	SW	-2	7	V
	SW (transient 20 ns and E = 5 µJ)	-3		
	COMP, VREF	-0.3	3.6	
	PGOOD	-0.3	7	
	PGND	-0.3	0.3	
Operating junction temperature, T _J		-40	150	°C
Lead temperature 1,6 mm (1/16 inch) from case for 10 seconds			300	°C
Storage temperature, T _{stg}		-55	150	°C

- (1) Stresses beyond those listed under *Absolute Maximum Ratings* may cause permanent damage to the device. These are stress ratings only, which do not imply functional operation of the device at these or any other conditions beyond those indicated under *Recommended Operating Conditions*. Exposure to absolute-maximum-rated conditions for extended periods may affect device reliability.

6.2 ESD Ratings

			VALUE	UNIT
V _(ESD)	Electrostatic discharge	Human-body model (HBM), per ANSI/ESDA/JEDEC JS-001 ⁽¹⁾	±2000	V
		Charged-device model (CDM), per JEDEC specification JESD22-C101 ⁽²⁾	±500	

- (1) JEDEC document JEP155 states that 500-V HBM allows safe manufacturing with a standard ESD control process. Manufacturing with less than 500-V HBM is possible with the necessary precautions. Pins listed as ±2000 V may actually have higher performance.
- (2) JEDEC document JEP157 states that 250-V CDM allows safe manufacturing with a standard ESD control process. Manufacturing with less than 250-V CDM is possible with the necessary precautions. Pins listed as ±500 V may actually have higher performance.

6.3 Recommended Operating Conditions

over operating free-air temperature range (unless otherwise noted)

		MIN	NOM	MAX	UNIT
Input voltage range	BST (with respect to SW), EN, VIN	-0.1		6.5	V
	V5IN	4.5		6.5	
	BST	-0.1		13.5	
	SW	-1.0		6.5	
	VOUT, MODE, REFIN	-0.1		3.5	
Output voltage range	COMP	-0.1		3.5	V
	VREF		2		
	PGOOD	-0.1		6.5	
	PGND	-0.1		0.1	
Operating temperature range, T _A		-40		85	°C

6.4 Thermal Information

THERMAL METRIC ⁽¹⁾		TPS53317A	UNIT
		RGB (VQFN)	
		20 PINS	
R _{θJA}	Junction-to-ambient thermal resistance	35.5	°C/W
R _{θJC(top)}	Junction-to-case (top) thermal resistance	39.6	°C/W
R _{θJB}	Junction-to-board thermal resistance	12.4	°C/W
ψ _{JT}	Junction-to-top characterization parameter	0.5	°C/W
ψ _{JB}	Junction-to-board characterization parameter	12.5	°C/W
R _{θJC(bot)}	Junction-to-case (bottom) thermal resistance	3.7	°C/W

(1) For more information about traditional and new thermal metrics, see the *Semiconductor and IC Package Thermal Metrics* application report, [SPRA953](#).

6.5 Electrical Characteristics

over recommended free-air temperature range, V_{V5IN} = 5.0 V, PGND = GND (unless otherwise noted)

PARAMETER	TEST CONDITIONS	MIN	TYP	MAX	UNIT	
SUPPLY: VOLTAGE, CURRENTS AND 5-V UVLO						
I _{VINSD}	VIN shutdown current	EN = 'LO'	0.02	5	μA	
V _{V5IN}	V5IN supply voltage	V5IN voltage range	4.5	5.0	6.5	V
I _{V5IN}	V5IN supply current	EN = 'HI', V5IN supply current, f _{SW} = 600 kHz	1.1	2	mA	
I _{V5INSD}	V5IN shutdown current	EN = 'LO', V5IN shutdown current	0.2	7.0	μA	
V _{V5UVLO}	V5IN UVLO	Ramp up; EN = 'HI'	4.20	4.37	4.50	V
V _{V5UVHYS}	V5IN UVLO hysteresis	Falling hysteresis	440		mV	
V _{VREFUVLO}	REF UVLO ⁽¹⁾	Rising edge of VREF, EN = 'HI'	1.8		V	
V _{VREFUVHYS}	REF UVLO hysteresis ⁽¹⁾		100		mV	
V _{POR5VFILT}	Reset	OVP latch is reset by V5IN falling below the reset threshold	1.5	2.3	3.1	V
VOLTAGE FEEDBACK LOOP: VREF, VOUT, AND VOLTAGE GM AMPLIFIER						
V _{OUTTOL}	Output voltage accuracy	V _{REFIN} = 1 V, No droop	-1%	0%	1%	
		V _{REFIN} = 0.6 V, No droop	-1%	0%	1%	
V _{VREF}	VREF	I _{VREF} = 0 μA	1.98	2.00	2.02	V
		I _{VREF} = 50 μA	1.975	2.000	2.025	
I _{REFSNK}	VREF sink current	V _{VREF} = 2.05 V	2.5		mA	
g _M	Transconductance		1.00		mS	
V _{CM}	Common mode input voltage range ⁽¹⁾		0	2	V	
V _{DM}	Differential mode input voltage		0	80	mV	
I _{COMPSNK}	COMP pin maximum sinking current	V _{COMP} = 2 V, (V _{REFIN} - V _{OUT}) = 80 mV	80		μA	
I _{COMPSRC}	COMP pin maximum sourcing current	V _{COMP} = 2 V	-80		μA	
V _{OFFSET}	Input offset voltage	T _A = 25°C	0		mV	
R _{DSCH}	Output voltage discharge resistance		42		Ω	
f _{-3dBVL}	-3dB Frequency ⁽¹⁾		4.5	6.0	7.5	MHz
CURRENT SENSE: CURRENT SENSE AMPLIFIER, OVERCURRENT AND ZERO CROSSING						
A _{CSINT}	Internal current sense gain	Gain from the current of the low-side FET to PWM comparator when PWM = "OFF"	43	53	57	mV/A
I _{OCL}	Positive overcurrent limit (valley)		7.6		A	
I _{OCL(neg)}	Negative overcurrent limit (valley)		-9.3		A	
V _{ZXOFF}	Zero crossing comp internal offset		0		mV	

(1) Ensured by design, not production tested.

Electrical Characteristics (continued)

 over recommended free-air temperature range, $V_{V5IN} = 5.0\text{ V}$, PGND = GND (unless otherwise noted)

PARAMETER		TEST CONDITIONS	MIN	TYP	MAX	UNIT
PROTECTION: OVP, UVP, PGOOD, and THERMAL SHUTDOWN						
V_{PGDLL}	PGOOD deassert to lower (PGOOD → Low)	Measured at the VOUT pin wrt/ V_{REFIN}		84%		
$V_{PGHYSHL}$	PGOOD high hysteresis			8%		
V_{PGDLH}	PGOOD de-assert to higher (PGOOD → Low)	Measured at the VOUT pin wrt/ V_{REFIN}		116%		
$V_{PGHYSHH}$	PGOOD high hysteresis			-8%		
$V_{INMINPG}$	Minimum VIN voltage for valid PGOOD	Measured at the VIN pin with a 2-mA sink current on PGOOD pin. V5IN is grounded here. ⁽²⁾	0.9	1.3	1.5	V
V_{OVP}	OVP threshold	Measured at the VOUT pin wrt/ V_{REFIN} , $V_{REFIN} = 1\text{ V}$	117%	120%	123%	
V_{UVP}	UVP threshold	Measured at the VOUT pin wrt/ V_{REFIN} , device latches OFF, begins soft-stop, $V_{REFIN} = 1\text{ V}$	65%	68%	71%	
TH_{SD}	Thermal shutdown ⁽¹⁾	Latch off controller, attempt soft-stop.		145		°C
$TH_{SD(hys)}$	Thermal Shutdown hysteresis ⁽¹⁾	Controller re-starts after temperature has dropped		10		°C
DRIVERS: BOOT STRAP SWITCH						
$R_{DSONBST}$	Internal BST switch on-resistance	$I_{BST} = 10\text{ mA}$, $T_A = 25^\circ\text{C}$			10	Ω
I_{BSTLK}	Internal BST switch leakage current	$V_{BST} = 14\text{ V}$, $V_{SW} = 7\text{ V}$			1	μA
TIMERS: ON-TIME, MINIMUM OFF-TIME, SS, AND I/O TIMINGS						
$t_{ONESHOTC}$	PWM one-shot ⁽¹⁾	$V_{VIN} = 5\text{ V}$, $V_{VOUT} = 1.05\text{ V}$, $f_{SW} = 1\text{ MHz}$		210		ns
		$V_{VIN} = 5\text{ V}$, $V_{VOUT} = 1.05\text{ V}$, $f_{SW} = 600\text{ kHz}$		310		
$t_{MIN(off)}$	Minimum OFF time	$V_{VIN} = 5\text{ V}$, $V_{VOUT} = 1.05\text{ V}$, $f_{SW} = 1\text{ MHz}$, DRVL on, SW = PGND, $V_{VOUT} < V_{REFIN}$		270		ns
$t_{INT(SS)}$	Soft-start time	From V_{OUT} ramp starting to $V_{OUT} = 95\%$, default setting		1.6		ms
$t_{INT(SSDLY)}$	Internal soft-start delay time	From $V_{VREF} = 2\text{ V}$ to V_{OUT} is ready to ramp up		260		μs
t_{PGDPLY}	PGOOD startup delay time	At external tracking, the time from VOUT is ready to ramp up		8		ms
$t_{PGDPDLYH}$	PGOOD high propagation delay time	50 mV over drive, rising edge	0.8	1	1.2	ms
$t_{PGDPDLYL}$	PGOOD low propagation delay time	50 mV over drive, falling edge		10		μs
t_{OVPDLY}	OVP delay time	Time from the VOUT pin out of +20% of V_{REFIN} to OVP fault		10		μs
$t_{UVDLYEN}$	Undervoltage fault enable delay	Time from EN_INT going high to undervoltage fault is ready		2		ms
		External tracking from VOUT ramp starts		8		
t_{UVPDLY}	UVP delay time	Time from the VOUT pin out of -32% of V_{REFIN} to UVP fault		256		μs
LOGIC PINS: I/O VOLTAGE AND CURRENT						
	PGOOD pull-down voltage	PGOOD low impedance, $I_{SINK} = 4\text{ mA}$, $V_{V5IN} = 4.5\text{ V}$			0.3	V
	PGOOD leakage current	PGOOD high impedance, forced to 5.5 V	-1	0	1	μA
	EN logic high	EN, VCCP logic	2			V
	EN logic low	EN, VCCP logic			0.5	V
	EN input current				1	μA

(2) If V5IN is higher than 1.5 V, PGOOD is valid regardless of the voltage applied at VIN. This is based on bench testing.

Electrical Characteristics (continued)

over recommended free-air temperature range, $V_{VIN} = 5.0\text{ V}$, PGND = GND (unless otherwise noted)

PARAMETER	TEST CONDITIONS	MIN	TYP	MAX	UNIT
MODE threshold voltage ⁽³⁾	Threshold 1	80	130	180	mV
	Threshold 2	200	250	300	
	Threshold 3	370	420	470	
	Threshold 4	550	600	650	
	Threshold 5	830	880	930	
	Threshold 6	1200	1250	1300	
	Threshold 7	1765	1800	1850	
MODE current			15		µA

(3) See Table 1 for descriptions of MODE parameters.

6.6 Typical Characteristics

Characterization data tested using the TPS53317A-EVM-726 where the external tracking input sets the output voltage and operates in non-droop mode. See SLUUBD2 for detailed configuration.

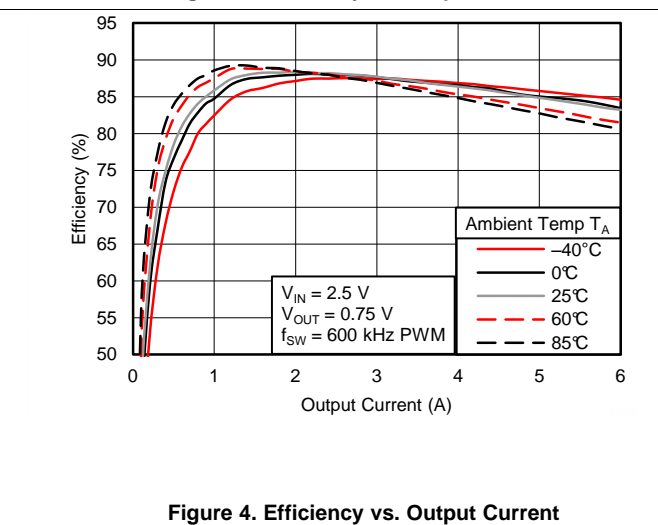
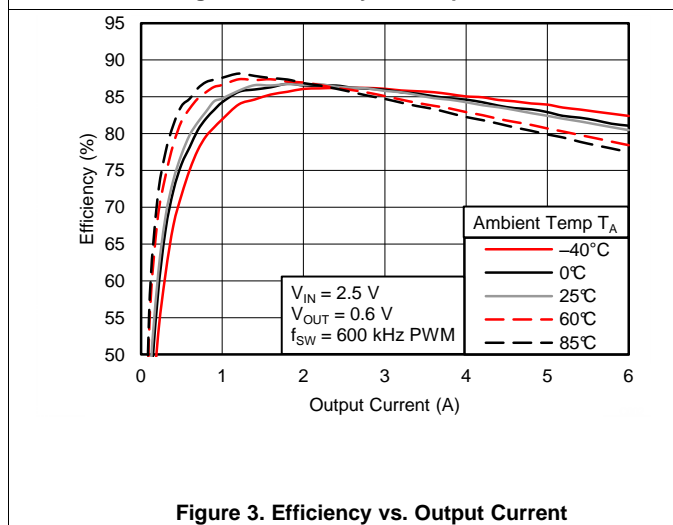
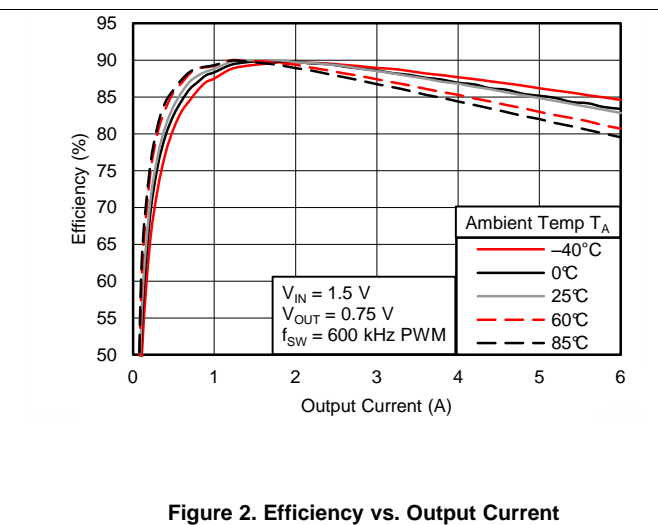
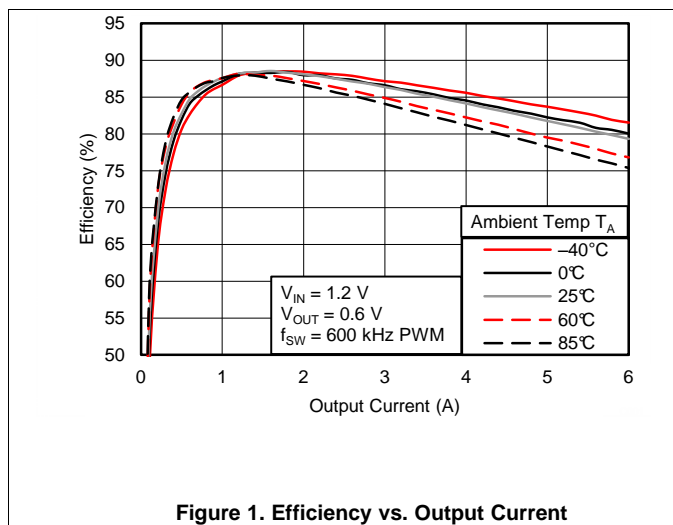

Typical Characteristics (continued)

Characterization data tested using the TPS53317AEVM-726 where the external tracking input sets the output voltage and operates in non-droop mode. See [SLUUBD2](#) for detailed configuration.

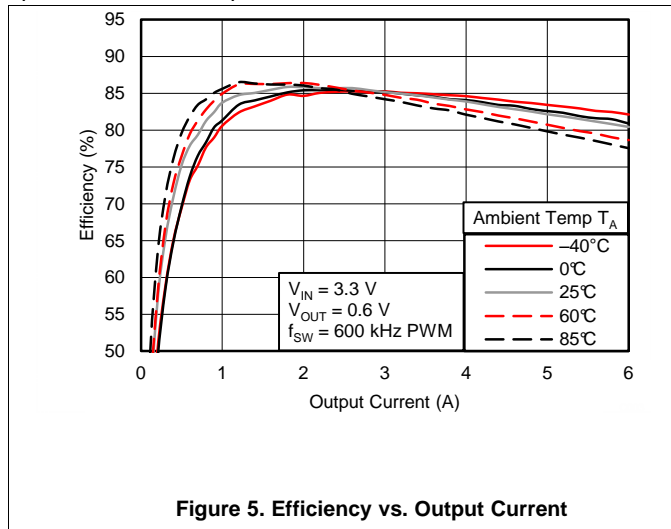

Figure 5. Efficiency vs. Output Current

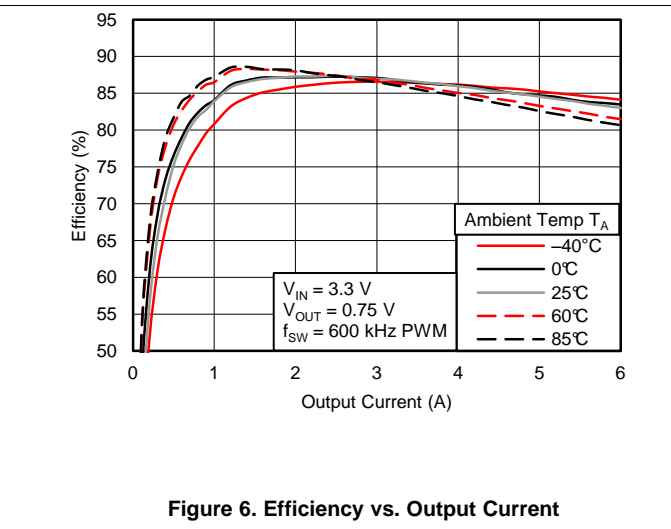

Figure 6. Efficiency vs. Output Current

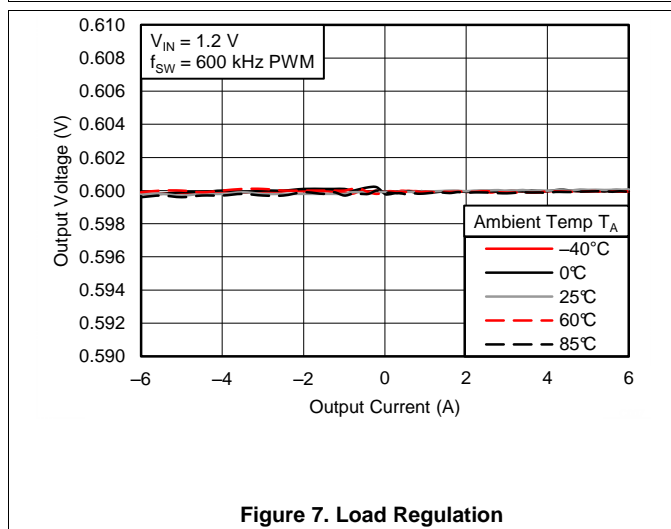

Figure 7. Load Regulation

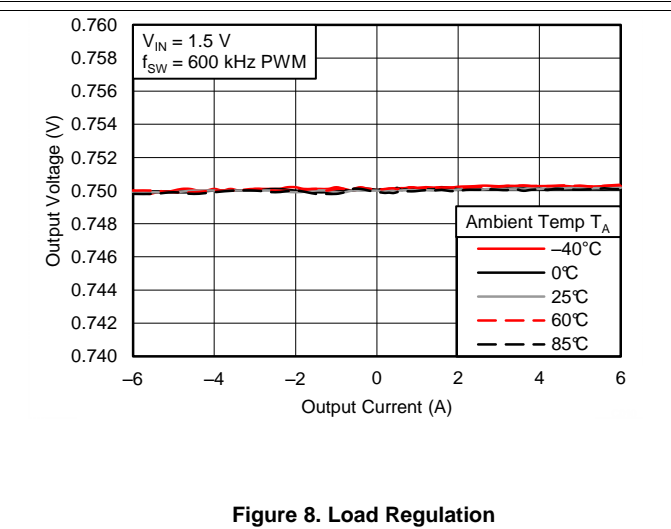

Figure 8. Load Regulation

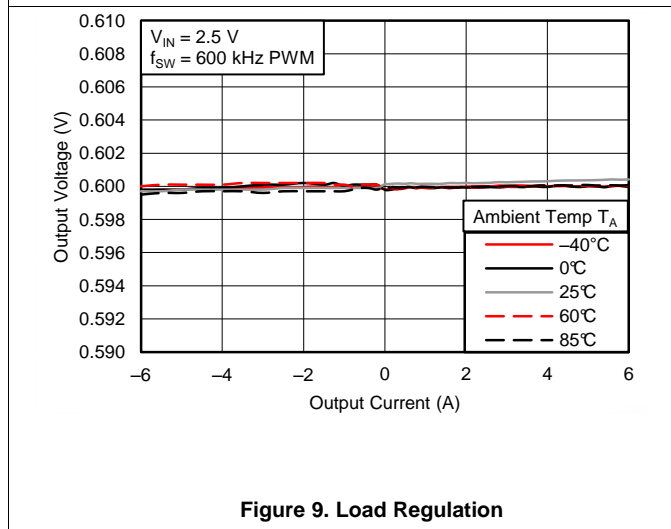

Figure 9. Load Regulation

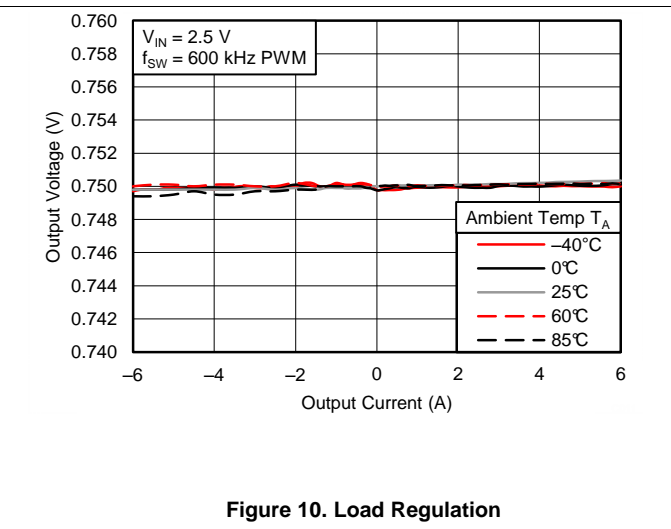
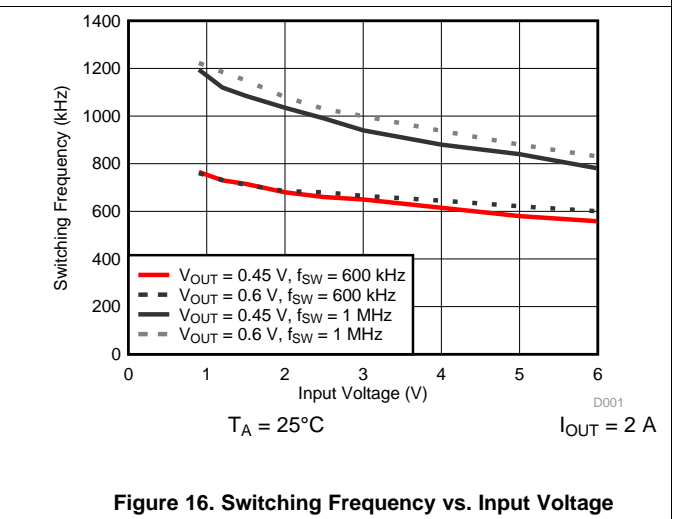
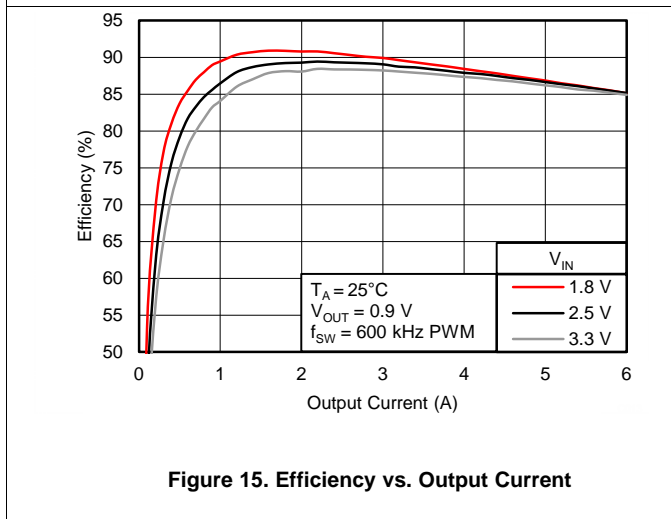
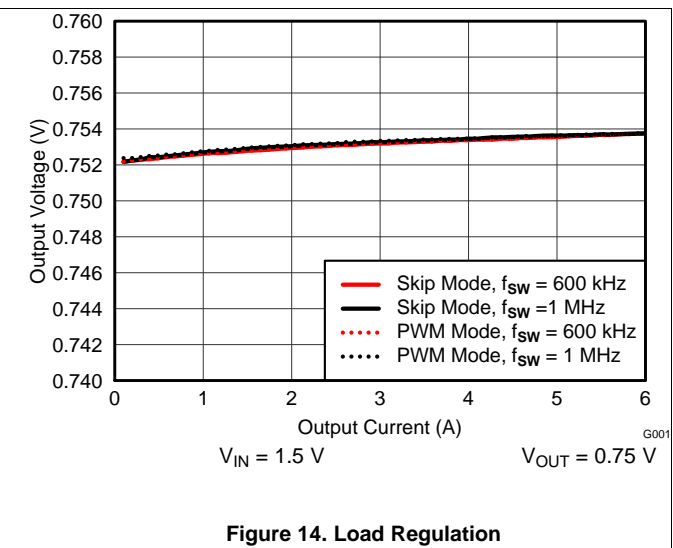
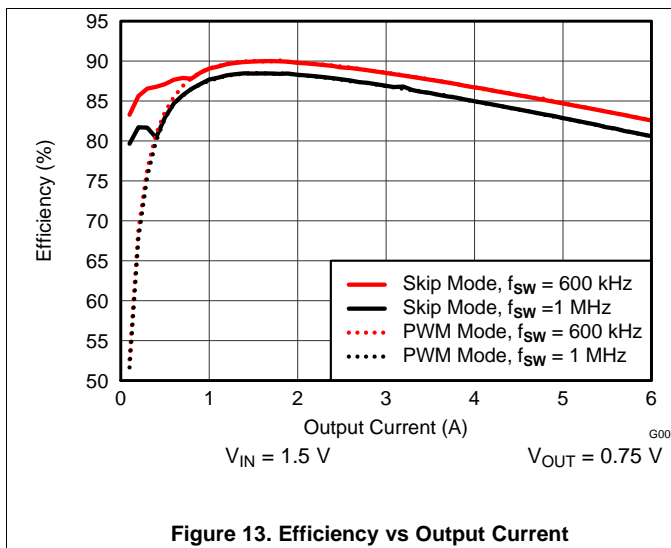
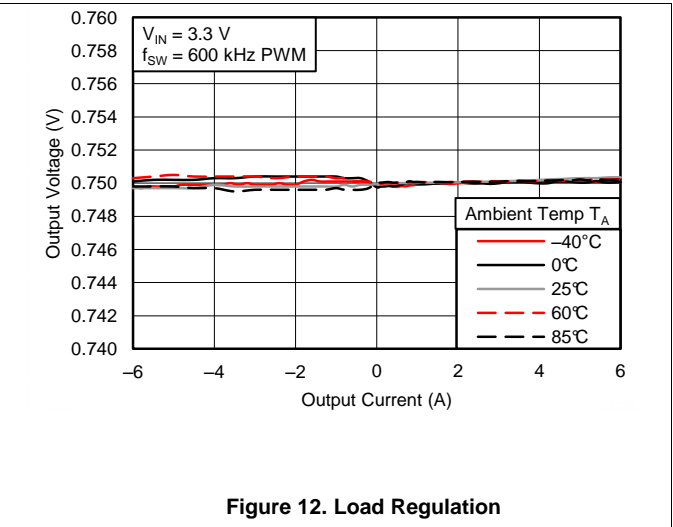
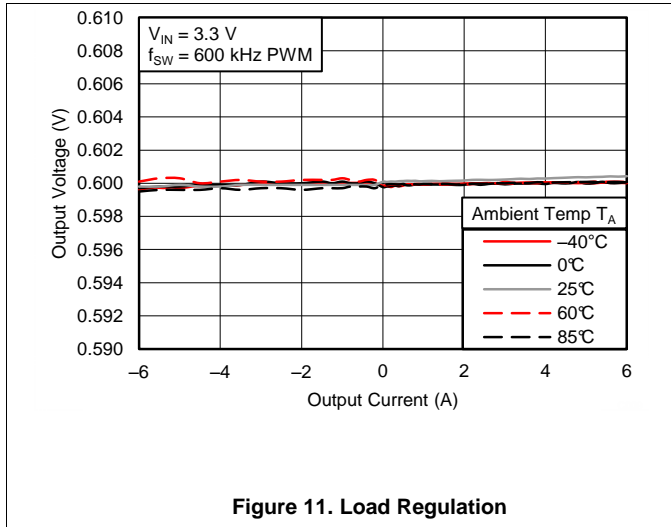

Figure 10. Load Regulation

Typical Characteristics (continued)

Characterization data tested using the TPS53317AEVM-726 where the external tracking input sets the output voltage and operates in non-droop mode. See [SLUUBD2](#) for detailed configuration.



7 Detailed Description

7.1 Overview

The TPS53317A device is a D-CAP+™ mode adaptive on-time converter. Integrated high-side and low-side FETs support a maximum of 6-A DC output current. The converter automatically operates in discontinuous conduction mode (DCM) to optimize light-load efficiency. Multiple switching frequencies are provided to enable optimization of the power train for the cost, size and efficiency requirements of the design (see Table 1).

In adaptive on-time converters, the controller varies the on-time as a function of input and output voltage to maintain a nearly constant frequency during steady-state conditions. In conventional constant on-time converters, each cycle begins when the output voltage crosses to a fixed reference level. However, in the TPS53317A device, the cycle begins when the current feedback reaches an error voltage level which is the amplified difference between the reference voltage and the feedback voltage.

7.2 Functional Block Diagram

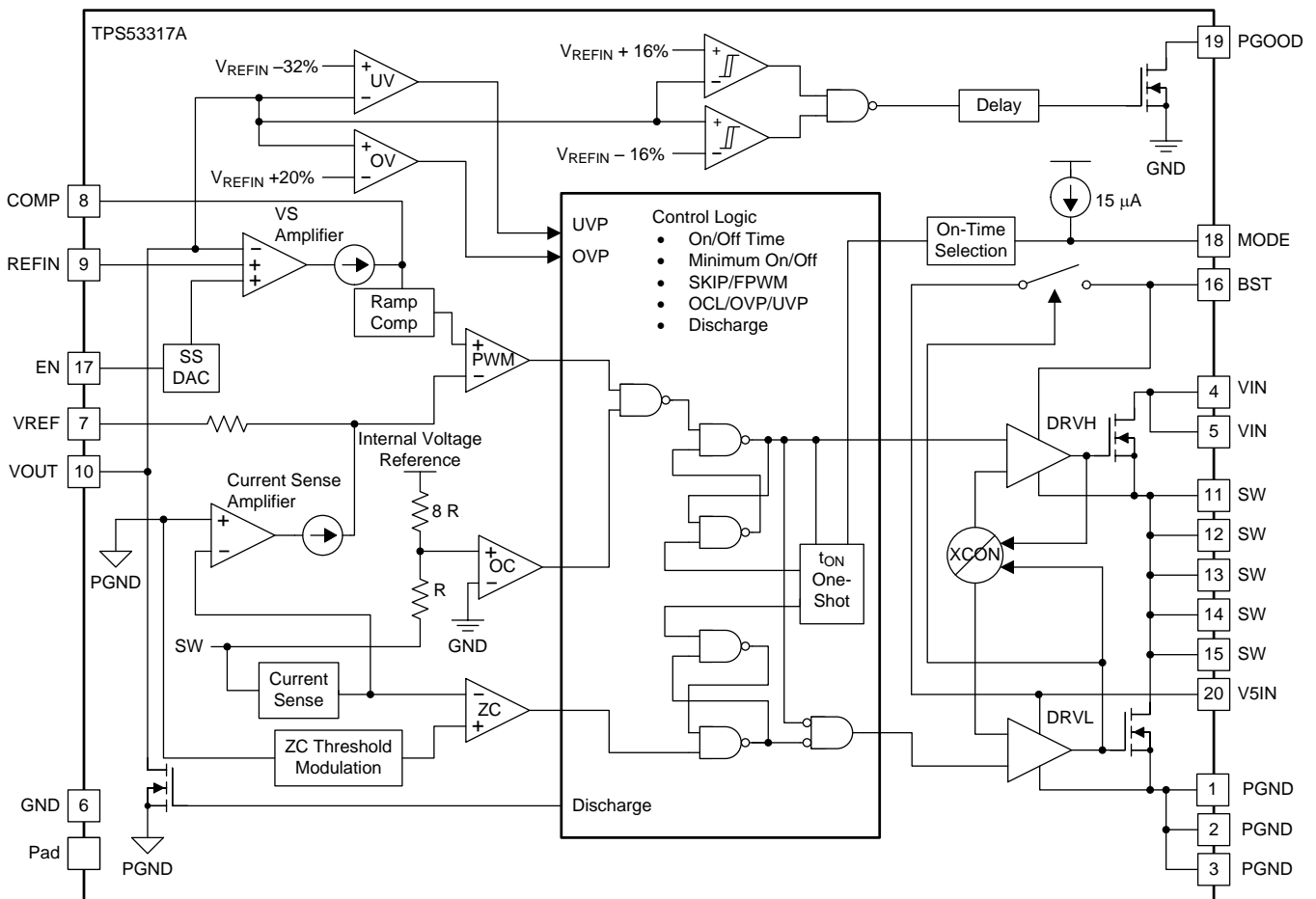

UDG-11106

7.3 Feature Description

7.3.1 PWM Operation

Referring to [Figure 17](#), in steady state, continuous conduction mode, the converter operates in the following way.

Starting with the condition that the top FET is off and the bottom FET is on, the current feedback (V_{CS}) is higher than the error amplifier output (V_{COMP}). V_{CS} falls until it hits V_{COMP} , which contains a component of the output ripple voltage. V_{CS} is not directly accessible by measuring signals on pins of TPS53317A device. The PWM comparator senses where the two waveforms cross and triggers the on-time generator.

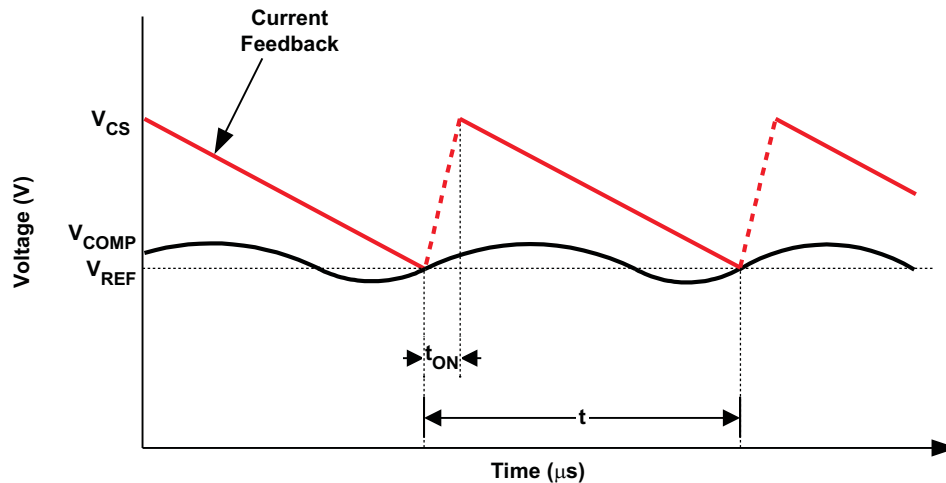

UDG-10187

Figure 17. D-CAP+™ Mode Basic Waveforms

The current feedback is an amplified and filtered version of the voltage between PGND and SW during low-side FET on-time. The device also provides a single-ended voltage (V_{OUT}) feedback to increase the system accuracy and reduce the dependence of circuit performance on layout.

7.3.2 PWM Frequency and Adaptive On-Time Control

In general, the on-time (at the SW node) can be estimated by [Equation 1](#).

$$t_{ON} = \frac{V_{OUT}}{V_{IN}} \times \frac{1}{f_{SW}}$$

where

- f_{SW} is the frequency selected by the connection of the MODE pin (1)

The on-time pulse is sent to the top FET. The inductor current and the current feedback rises to peak value. Each ON pulse is latched to prevent double pulsing. Switching frequency settings are shown in [Table 1](#).

7.3.3 Light-Load Power Saving Features

The TPS53317A device has an automatic pulse-skipping mode to provide excellent efficiency over a wide load range. The converter senses inductor current and prevents negative flow by shutting off the low-side gate driver. This saves power by eliminating re-circulation of the inductor current. Further, when the bottom FET shuts off, the converter enters discontinuous mode, and the switching frequency decreases, thus reducing switching losses as well.

The device also provides a special light-load power saving feature, called ripple reduction. Essentially, it reduces the on-time in SKIP mode to effectively reduce the output voltage ripple associated with using an all MLCC capacitor output power stage design.

Feature Description (continued)

7.3.4 Power Sequences

7.3.4.1 Non-Tracking Startup

The TPS53317A device can be configured for non-tracking application. When non-tracking is configured, output voltage is regulated to the REFIN voltage which taps off the voltage dividers from the 2-V reference voltage. Either the EN pin or the V5IN pin can be used to start up the device. The device uses internal voltage servo DAC to provide a 1.6-ms soft-start time during soft-start initialization. (See [Figure 19](#).)

In a non-tracking application, the output voltage is determined by the resistive divider between the VREF pin and the REFIN pin.

$$V_{OUT} = V_{REF} \times \frac{R2}{R1+R2} \tag{2}$$

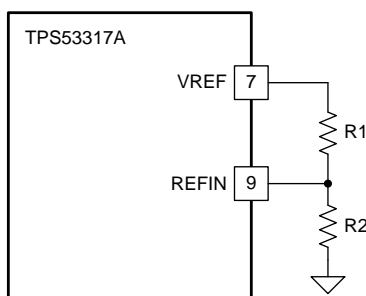

Figure 18. Non-Tracking Configuration

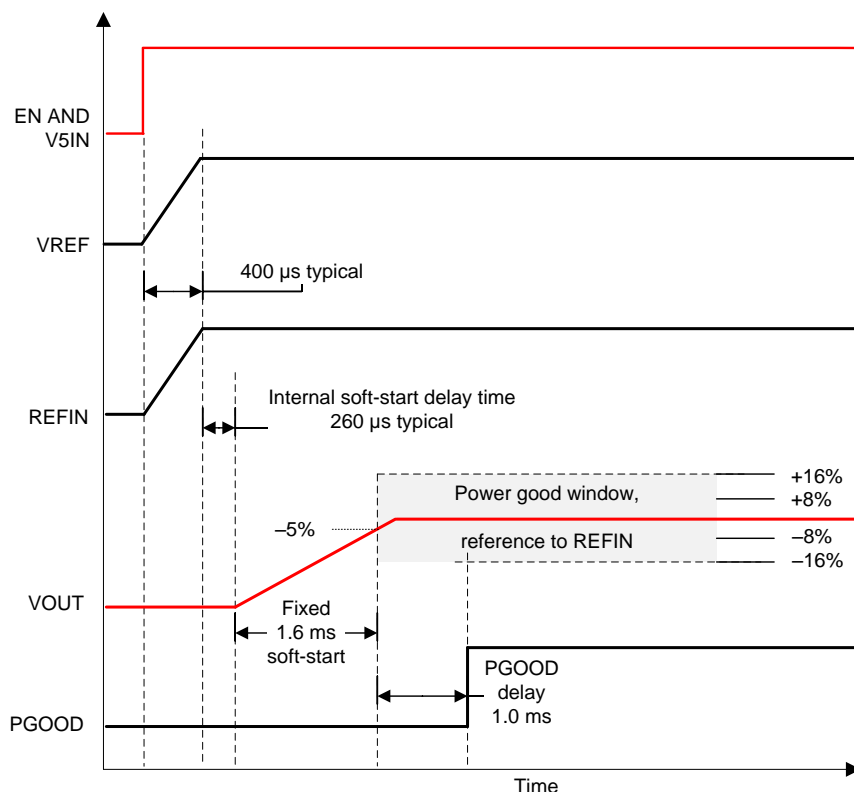

Figure 19. Non-Tracking Startup Timing

Feature Description (continued)

7.3.4.2 Tracking Startup

The TPS53317A device can also be configured for tracking application. When tracking configuration is desired, output voltage is also regulated to the REFIN voltage which comes from an external power source. In order for the device to differentiate between a non-tracking configuration or a tracking configuration, there is a minimum delay time of 260 μs required between the time when VREF reaches 2 V to the time when the REFIN pin voltage can be applied, in order for the device to track properly (see Figure 22). The valid REFIN voltage range is between 0.45 V and 2 V.

In a tracking application, the output voltage should be one half of the VDDQ voltage. VDDQ can be VIN or it can be an additional voltage rail. Thus, R1= R2 both in Figure 20 and Figure 21.

$$V_{OUT} = \frac{1}{2} \times V_{VDDQ} \tag{3}$$

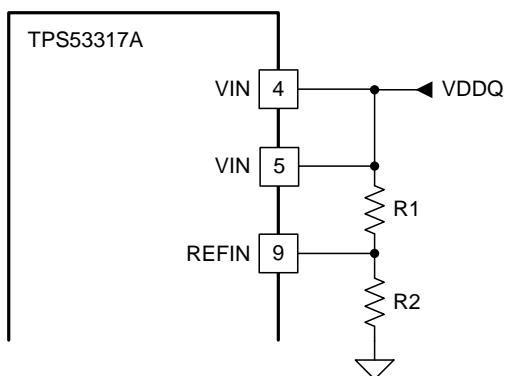

Figure 20. Tracking Configuration 1

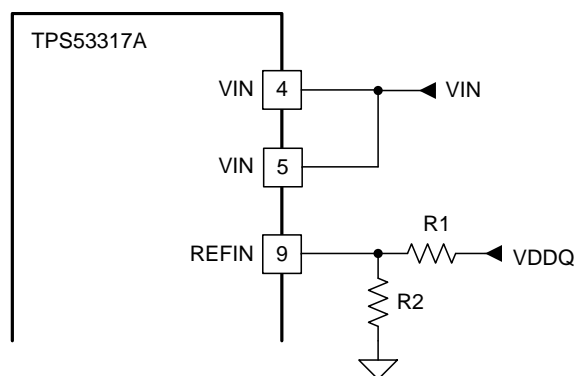

Figure 21. Tracking Configuration 2

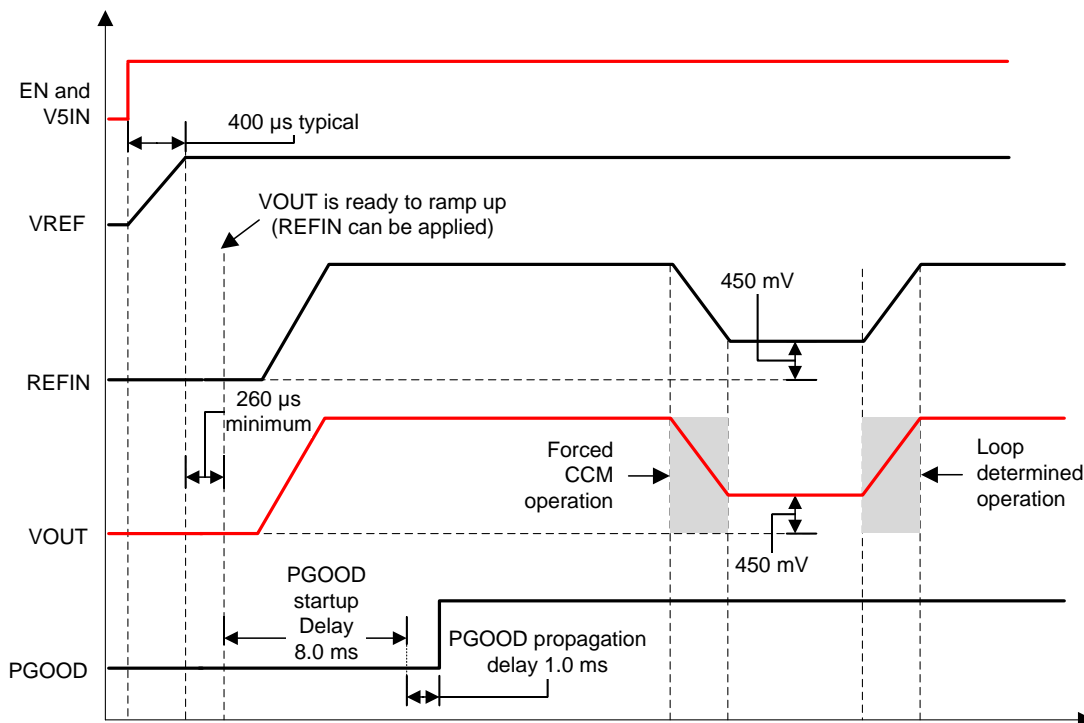

Figure 22. Tracking Startup Timing

Select PWM mode for an application that requires external tracking, because the output voltage can not be decreased during a no-load condition when the device operates in SKIP mode.

Feature Description (continued)

7.3.5 Protection Features

The TPS53317A device offers many features to protect the converter power train as well as the system electronics.

7.3.5.1 5-V Undervoltage Protection (UVLO)

The TPS53317A device continuously monitors the voltage on the V5IN pin to ensure that the voltage level is high enough to bias the device properly and to provide sufficient gate drive potential to maintain high efficiency. The converter starts with approximately 4.3 V and has a nominal 440 mV of hysteresis. If the 5-V UVLO limit is reached, the converter transitions the phase node into an off function, and the converter remains in the off state until the device is reset by cycling the 5-V supply until the 5-V POR is reached (2.3-V nominal). The power input does not have a UVLO function.

7.3.5.2 Power Good Signals

The TPS53317A device has one open-drain *power good* (PGOOD) pin. During startup, there is a 1-ms power good high propagation delay. The PGOOD pin de-asserts as soon as the EN pin is pulled low or an undervoltage condition on V5IN or any other fault is detected.

7.3.5.3 Output Overvoltage Protection (OVP)

In addition to the power good function described above, the TPS53317A device has additional OVP and UVP thresholds and protection circuits.

An OVP condition is detected when the output voltage is approximately $120\% \times V_{REFIN}$. In this case, the converter de-asserts the PGOOD signals and performs the overvoltage protection function. During OVP, the low-side FET is always on before triggering a negative overcurrent. When a negative OC is also tripped, the low-side FET is no longer continuously on, and pulsed signals are generated to limit the negative inductor current. When the VOUT pin voltage drops below 250 mV, the low-side FET turns off and the converter latches off. The converter remains in the off state until the device is reset by cycling the 5-V supply until the 5-V POR is reached (2.3-V nominal) or when the EN pin is toggled off and on.

7.3.5.4 Output Undervoltage Protection (UVP)

Output undervoltage protection works in conjunction with the current protection described in the [Overcurrent Protection](#) and [Overcurrent Limit](#) sections. If the output voltage drops below 68% of V_{REFIN} , after approximately a 250- μ s delay, the device stops switching and enters hiccup mode. After a hiccup waiting time, a restart is attempted. If the fault condition is not cleared, hiccup mode operation may continue indefinitely.

7.3.5.5 Overcurrent Protection

Both positive and negative overcurrent protection are provided in the TPS53317A device.

- Overcurrent Limit (OCL)
- Negative OCL

7.3.5.5.1 Overcurrent Limit

If the sensed current value is above the OCL setting, the converter delays the next ON pulse until the current drops below the OCL limit. Current limiting occurs on a pulse-by-pulse basis. The device uses a valley current limiting scheme where the DC OCL trip point is the OCL limit plus half of the inductor ripple current. The typical valley OCL threshold is 7.6 A or 5.4 A (depending on mode selection). The average output current limit calculation is shown in [Equation 4](#).

During the overcurrent protection event, the output voltage droops if the duty cycle cannot satisfy output voltage requirements and continues to droop until the UVP limit is reached. Then, the converter de-asserts the PGOOD pin, and then enters hiccup mode after a 250- μ s delay. The converter remains in hiccup mode until the fault is cleared.

$$I_{OCL(dc)} = I_{OCL(valley)} + \frac{1}{2} \times I_{P-P} \quad (4)$$

Feature Description (continued)

7.3.5.5.2 Negative OCL

The negative OCL circuit acts when the converter is sinking current from the output capacitor(s). The converter continues to act in a *valley* mode, the typical value of the negative OCL set point is -9.3 A or -6.5 A (depending on mode selection).

7.3.6 Thermal Protection

The TPS53317A device has an internal temperature sensor. When the temperature reaches a nominal 145°C , the device shuts down until the temperature decreases by approximately 10°C , when the converter restarts.

7.4 Device Functional Modes

7.4.1 Non-Droop Configuration

The TPS53317A device can be configured as a non-droop solution. The benefit of a non-droop approach is that load regulation is flat, therefore, in a system where tight DC tolerance is desired, the non-droop approach is recommended. For the Intel system agent application, non-droop is recommended as the standard configuration.

The non-droop approach can be implemented by connecting a resistor and a capacitor between the COMP and the VREF pins. The purpose of the type II compensation is to obtain high DC feedback gain while minimizing the phase delay at unity gain cross over frequency of the converter.

The value of the resistor (R_C) can be calculated using the desired unity gain bandwidth of the converter, and the value of the capacitor (C_C) can be calculated by knowing where the zero location is desired. The capacitor C_P is optional, but recommended. Its appropriate capacitance value can be calculated using the desired pole location.

Figure 23 shows the basic implementation of the non-droop mode using the device

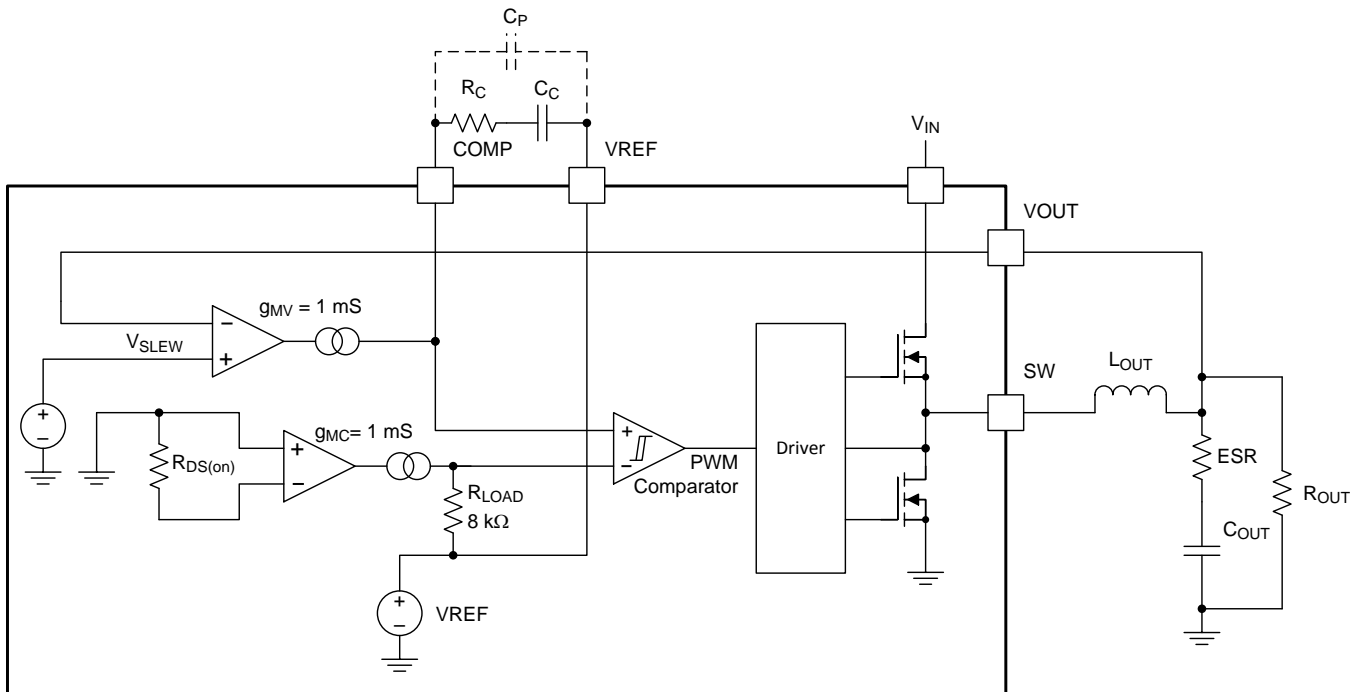
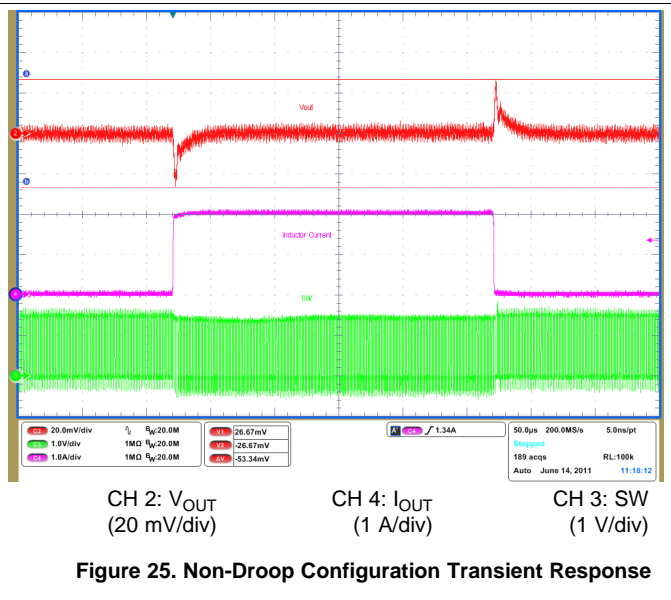
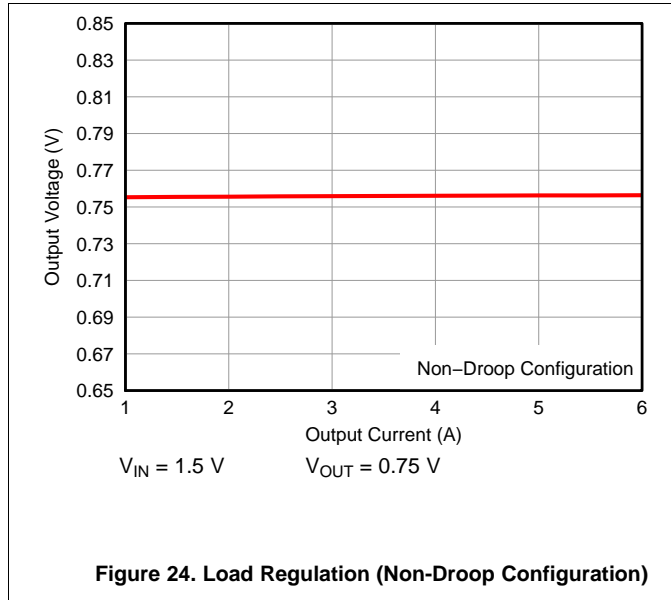

Figure 23. Non-Droop Mode Basic Implementation

Device Functional Modes (continued)

Figure 24 shows the load regulation using non-droop configuration.

Figure 25 shows the transient response of the device using non-droop configuration, where $C_{OUT} = 3 \times 47 \mu\text{F}$. The applied step load is from 0 A to 2 A.



7.4.2 Droop Configuration

The terminology for droop is the same as *load line* or *voltage positioning* as defined in the Intel CPU V_{CORE} specification. Based on the actual tolerance requirement of the application, load-line set points can be defined to maximize either cost savings (by reducing output capacitors) or power reduction benefits.

Accurate droop voltage response is provided by the finite gain of the droop amplifier. The equation for droop voltage is shown in Equation 5.

$$V_{DROOP} = \frac{A_{CSINT} \times I_{OUT}}{R_{DROOP} \times g_M}$$

where

- low-side on-resistance is used as the current sensing element
 - A_{CSINT} is a constant, which nominally is 53 mV/A.
 - I_{OUT} is the DC current of the inductor, or the load current
 - R_{DROOP} is the value of resistor from the COMP pin to the VREF pin
 - g_M is the transconductance of the droop amplifier with nominal value of 1 mS
- (5)

Equation 6 can be used to easily derive R_{DROOP} for any load line slope/droop design target.

$$R_{LOAD_LINE} = \frac{V_{DROOP}}{I_{OUT}} = \frac{A_{CSINT}}{R_{DROOP} \times g_M} \therefore R_{DROOP} = \frac{A_{CSINT}}{R_{LOAD_LINE} \times g_M}$$

(6)

Choose a value for the R_{DROOP} resistor that is below 20 kΩ. More than 20 kΩ of droop resistance may cause the loop to become unstable.

Device Functional Modes (continued)

Figure 26 shows the basic implementation of the droop mode using the TPS53317A device.

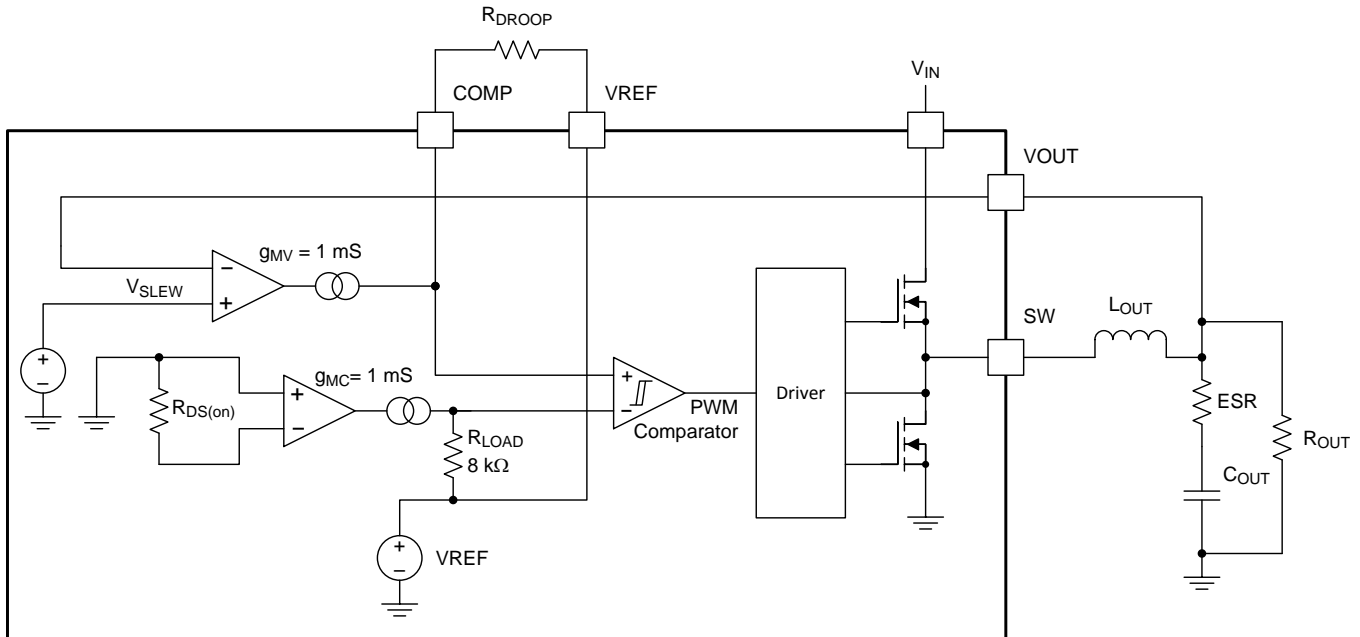

Figure 26. DROOP Mode Basic Implementation

The droop (voltage positioning) method was originally recommended to reduce the number of external output capacitors required. The effective transient voltage range is increased because of the active voltage positioning (see Figure 27).

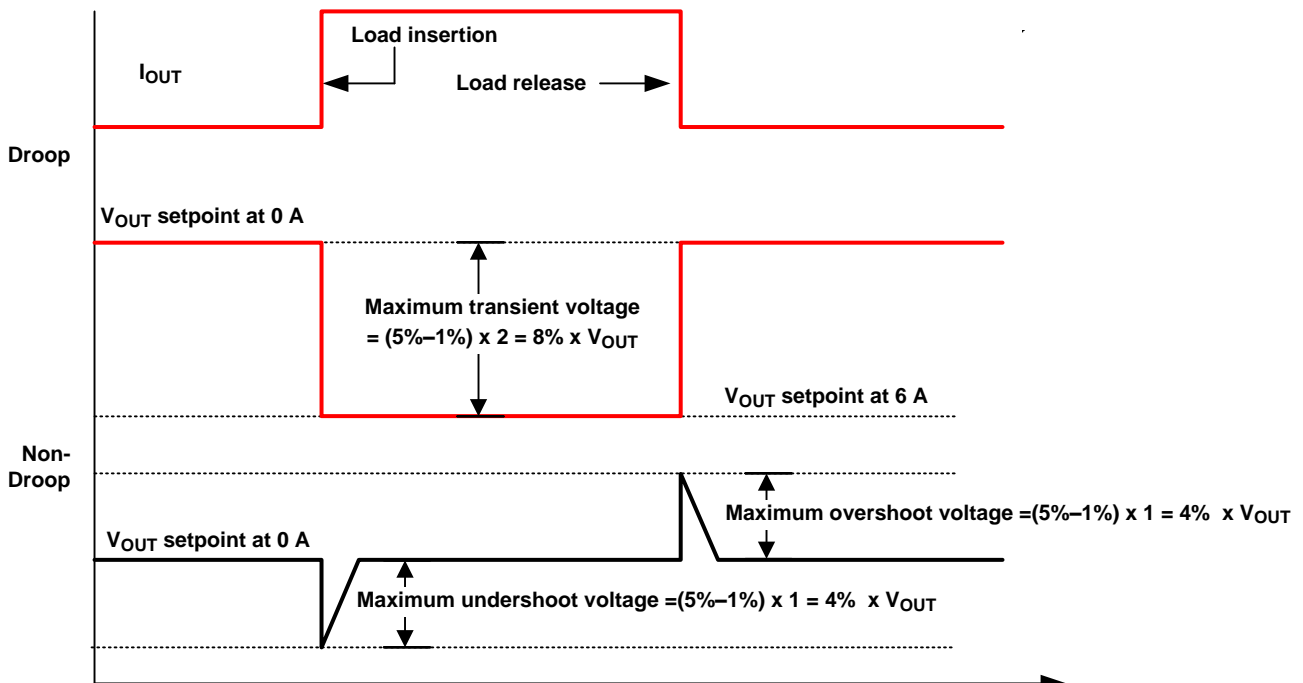

Figure 27. DROOP vs Non-DROOP in Transient Voltage Window

Device Functional Modes (continued)

In applications where the DC and the AC tolerances are not separated, (meaning that there is no strict DC tolerance requirement) the droop method can be used.

Table 1. Mode Definitions

MODE	MODE RESISTANCE (kΩ)	LIGHT-LOAD POWER SAVING MODE	SWITCHING FREQUENCY (f _{sw})	OVERCURRENT LIMIT (OCL) VALLEY (A)
1	0	SKIP	600 kHz	7.6
2	12		600 kHz	5.4
3	22		1 MHz	5.4
4	33		1 MHz	7.6
5	47	PWM	600 kHz	7.6
6	68		600 kHz	5.4
7	100		1 MHz	5.4
8	OPEN		1 MHz	7.6

Figure 28 shows the load regulation of the 1.5-V rail using an R_{DROOP} value of 6.8 kΩ.

Figure 29 shows the transient response of the TPS53317A device using droop configuration and C_{OUT} = 3 × 47 μF. The applied step load is from 0 A to 2 A.

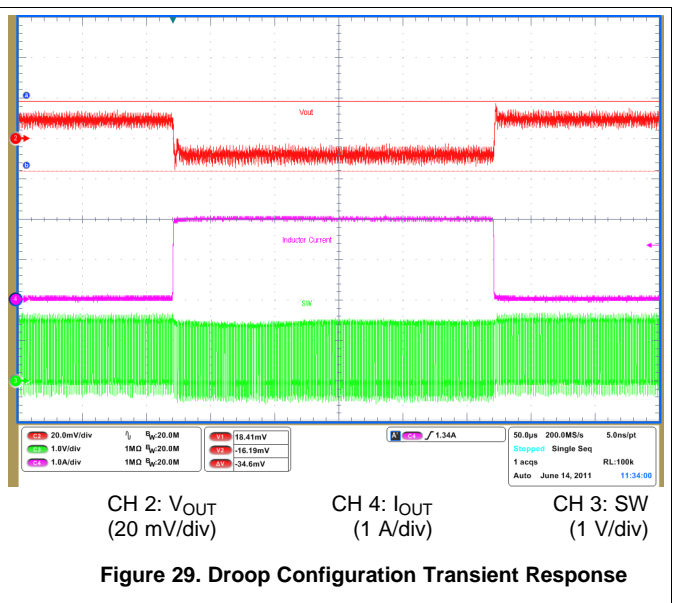
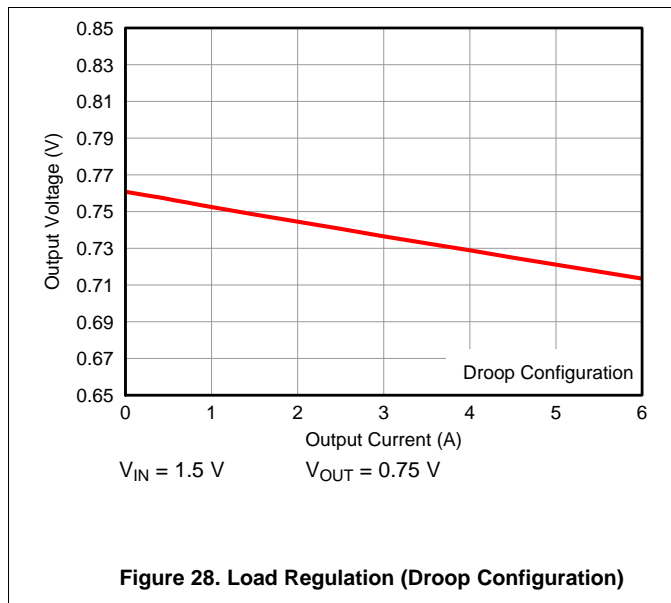

8 Application and Implementation

NOTE

Information in the following applications sections is not part of the TI component specification, and TI does not warrant its accuracy or completeness. TI's customers are responsible for determining suitability of components for their purposes. Customers should validate and test their design implementation to confirm system functionality.

8.1 Application Information

The TPS53317A device is a FET-integrated synchronous buck regulator designed mainly for DDR termination. It can provide a regulated output at $\frac{1}{2}$ VDDQ with both sink and source capability. The device employs D-CAP+ mode operation that provides ease-of-use, low external component count and fast transient response.

8.2 Typical Applications

8.2.1 DDR4 SDRAM Application

This DDR4 application requires a tight load tolerance, fast transient response, and sinking current capability, the design uses a non-droop PWM configuration.

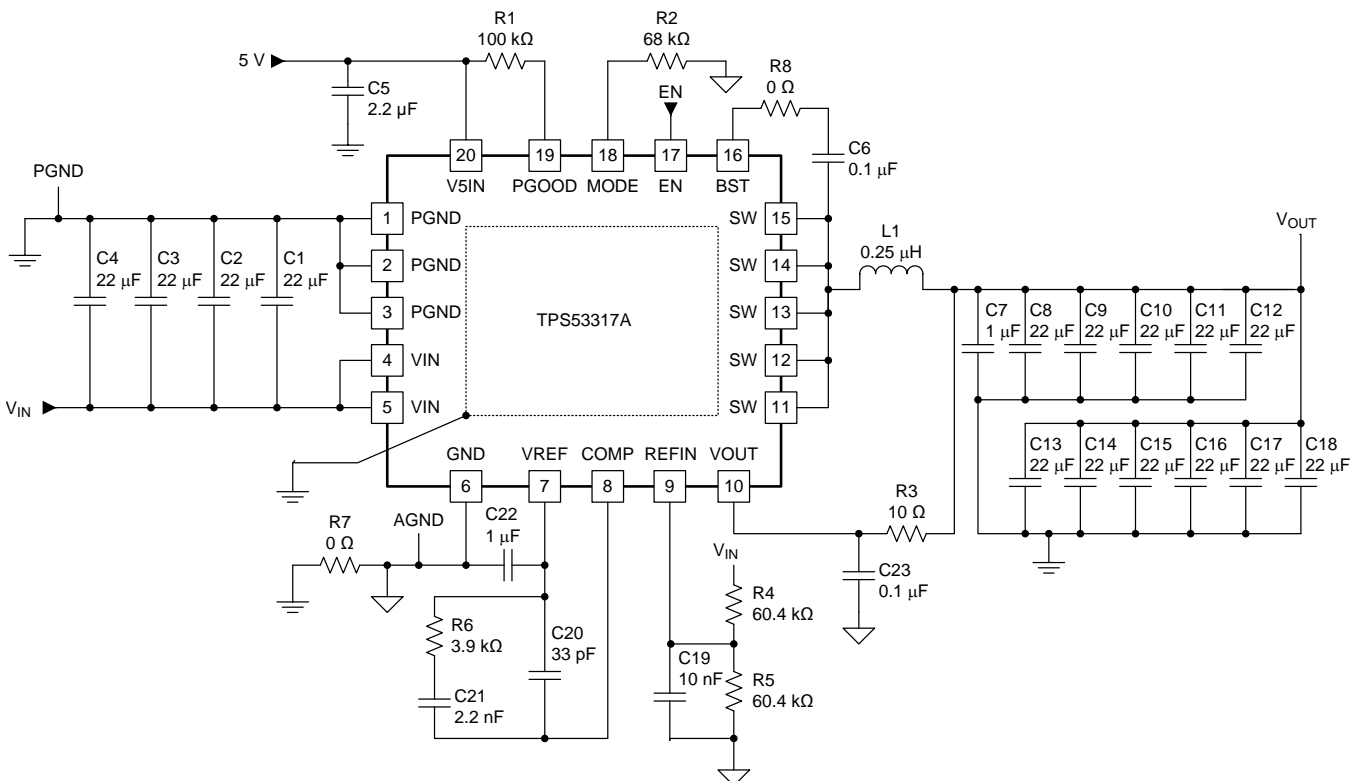

Figure 30. DDR4 SDRAM Application

8.2.1.1 Design Requirements

- Input voltage : $V_{IN} = 1.2$ V
- Output voltage: $V_{OUT} = 0.6$ V
- Maximum load step size of 3 A @ slew rate 7 A/µs (–1.5 A to 1.5 A)
- DC +AC + Ripple voltage regulation limit at sense point: ± 42 mV (0.642 V overshoot, 0.558 V undershoot)
- Maximum load: $I_{MAX} = 2.5$ A

Typical Applications (continued)

8.2.1.2 Detailed Design Procedure

8.2.1.2.1 Step 1. Determine Configuration

Because this DDR4 application requires a tight load tolerance, fast transient response, and sinking current capability, the design uses a non-droop PWM configuration. Choose 600-kHz switching frequency due to the duty cycle and minimum off-time of the device, and set an overcurrent (OC) valley limit of 5.4 A due to the maximum load requirement of 2.5 A. Referring to [Table 1](#) select an R_{MODE} value of 68 k Ω .

8.2.1.2.2 Step 2. Select Inductor

Smaller inductor values have better transient performance but higher ripple and lower efficiency. High values have the opposite characteristics. It is common practice to limit the ripple current to 30% to 50% of the maximum current. Choose 50% to allow use of a smaller inductor for faster transient performance.

$$\Delta I_{P-P} = 2.5 \text{ A} \times 0.5 = 1.25 \text{ A} \quad (7)$$

$$L = \frac{1}{f_{SW} \times \Delta I_{P-P}} \times V_{OUT} \times (1 - D)$$

where

- D = duty cycle (8)

Because this device operates in DCAP+ mode, the frequency and duty cycle vary based on the input voltage, the output voltage and load. With a 2.5-A load, a 1.2-V input voltage and 0.60 V output voltage, f_{SW} is experimentally measured at approximately 800 kHz and duty cycle of 0.55. Therefore L is calculated as shown in [Equation 10](#).

$$L = \frac{1}{(800 \text{ kHz} \times 1.25 \text{ A})} \times 0.6 \text{ V} \times 0.45 = 0.270 \mu\text{H} \quad (9)$$

Choose the closest standard value, 0.25 μH .

8.2.1.2.3 Step 3. Determine Output Capacitance

Use [Equation 10](#) to calculate the output capacitance for a desired maximum overshoot.

$$C_{OUT(min),OS} = \frac{\Delta I_{OUT}^2 \times L}{2 \times V_{OUT} \times V_{OS}}$$

where

- $C_{OUT(min),OS}$ is the minimum output capacitance for a desired overshoot
- ΔI_{OUT} is the maximum output current change in the application
- V_{OUT} = desired output voltage
- V_{OS} is the desired output voltage change due to overshoot (10)

Choose a value of 30 mV to account for normal output voltage ripple.

$$C_{OUT(min),OS} = \frac{(3 \text{ A})^2 \times 0.25 \mu\text{H}}{2 \times 0.6 \text{ V} \times 0.03 \text{ V}} = 62.5 \mu\text{F} \quad (11)$$

Use [Equation 12](#) to calculate the necessary output capacitance for a desired maximum undershoot.

$$C_{OUT(min),US} = \frac{\Delta I_{OUT}^2 \times L \times \left(\frac{V_{OUT}}{V_{IN}} \times t_{SW} + t_{MIN(off)} \right)}{2 \times V_{OUT} \times V_{US} \times \left(\frac{V_{IN} - V_{OUT}}{V_{IN}} \times t_{SW} - t_{MIN(off)} \right)}$$

where

- $C_{OUT(min),US}$ is the minimum output capacitance for a desired undershoot
- V_{US} is the desired output voltage change due to overshoot
- t_{SW} is the period of switch node
- $t_{MIN(off)}$ is the minimum off-time (270 ns) (12)

Typical Applications (continued)

Again, choose 30 mV to account for normal output voltage ripple.

$$C_{OUT(min),US} = \frac{(3 A)^2 \times 0.25 \mu H \times \left(\frac{0.6 V}{1.2 V} \times \frac{1}{800 kHz} + 270 ns \right)}{2 \times 0.6 V \times 0.03 V \times \left(\frac{1.2 V - 0.6 V}{1.2 V} \times \frac{1}{800 kHz} - 270 ns \right)} = 157.6 \mu F \quad (13)$$

The undershoot requirements determine, so there must be a minimum of 157.6 μF . Because this is a DDR application where size is also a consideration, this design uses only ceramic capacitors. To account for voltage de-rating of capacitors and provide additional margin, this design includes eleven 22- μF output capacitors.

8.2.1.2.4 Step 4. Input Capacitance

This design requires sufficient input capacitance to filter the input current from the host source. Use [Equation 14](#) to calculate the necessary input capacitance.

$$C_{IN(min)} = I_{out} \times \frac{D \times (1 - D)}{\Delta V_{IN(P-P)} \times f_{SW}}$$

where

- $\Delta V_{IN(P-P)}$ is the desired input voltage ripple (typically 1% of the input voltage) (14)

$$C_{IN(min)} = 2.5 A \times \frac{0.55 \times (1 - 0.55)}{12 mV \times 800 kHz} = 64.45 \mu F \quad (15)$$

As with the output capacitance selection, this design accounts for voltage de-rating of capacitors and provides additional margin, using four 22- μF input capacitors.

8.2.1.2.5 Step 5. Compensation Network

In order to achieve stable operation, the crossover frequency should be less than 1/5 of the switching frequency.

$$f_{CO} = \frac{1}{2\pi} \times \frac{g_M}{C_{OUT}} \times \frac{R_C}{R_S} = 80 kHz$$

where

- $R_S = 53 m\Omega$ (16)

Account for capacitor de-rating here and set the value of C_{OUT} to 160 μF , so that [Equation 17](#) is true.

$$R_C = \frac{f_{CO} \times R_S \times 2\pi \times C_{OUT}}{g_M} = \frac{80 kHz \times 53 m\Omega \times 2\pi \times 160 \mu F}{1 mS} = 4.26 k\Omega \quad (17)$$

Choose an R_C value of 3.9 $k\Omega$. Determine C_C by choosing the value of the zero created by R_C and C_C . Using the relationship described in [Equation 18](#).

$$f_z = \frac{f_{CO}}{5} = \frac{1}{2\pi \times R_C \times C_C} \quad (18)$$

[Equation 18](#) yields a C_C value of 2.55 nF. Choose the closest common capacitor value of 2.2 nF. To determine a value for C_P , first consider the relationship described in [Equation 19](#).

$$f_p = \frac{1}{2\pi \times R_C \times \frac{C_C \times C_P}{C_C + C_P}} \approx \frac{1}{2\pi \times R_C \times C_P} \quad (19)$$

- $C_C \gg C_P$

Because $C_C \gg C_P$, set the pole to be two times the switching frequency as described in [Equation 20](#).

$$C_P \cong \frac{1}{2\pi \times R_C \times 2f_{SW}} = \frac{1}{2\pi \times 3.9 k\Omega \times 2 \times 800 kHz} = 25.5 pF \quad (20)$$

To boost the gain margin, set C_P to 33 pF.

Typical Applications (continued)

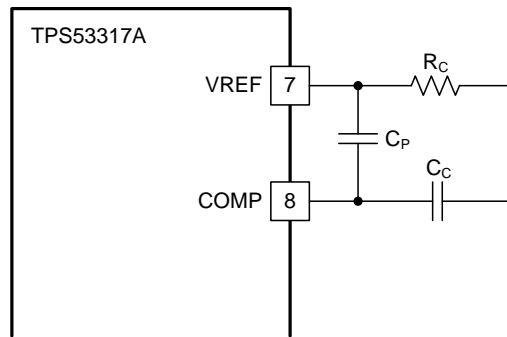

Figure 31. Compensation Network Circuit

8.2.1.2.6 Peripheral Component Selection

As described in Table 1, connect a 0.22- μ F capacitor from the VREF pin to GND and connect a 0.1- μ F bootstrap capacitor from the SW pin to the BST pin. Because the PGOOD pin is open drain, connect a pullup resistor between it and the 5-V rail.

8.2.1.3 Application Curves

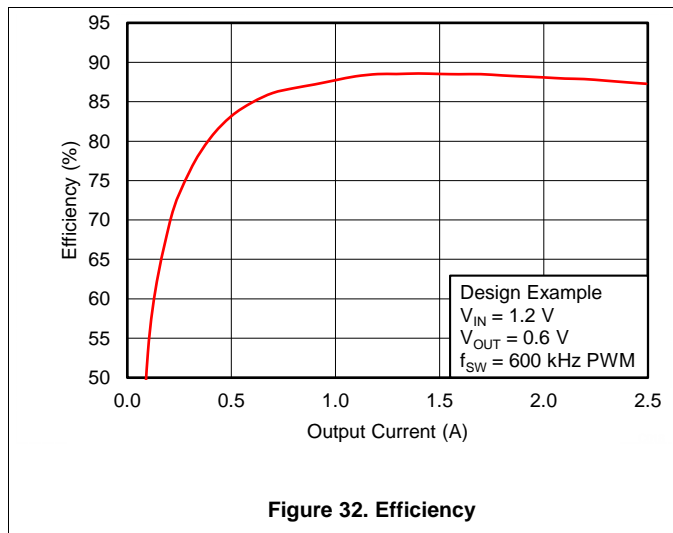

Figure 32. Efficiency

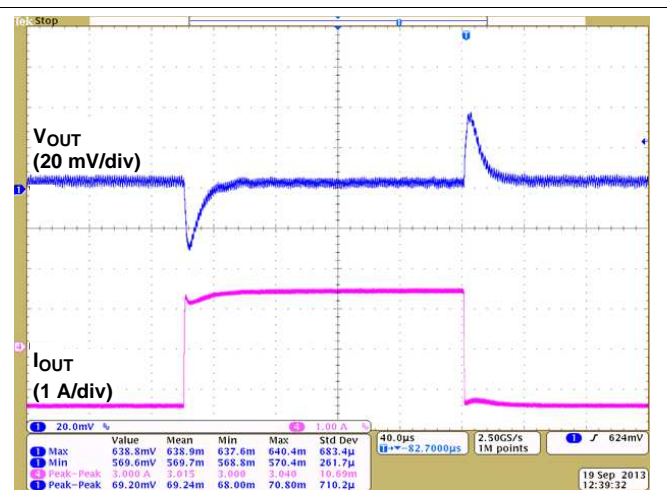

Figure 33. Load Transient

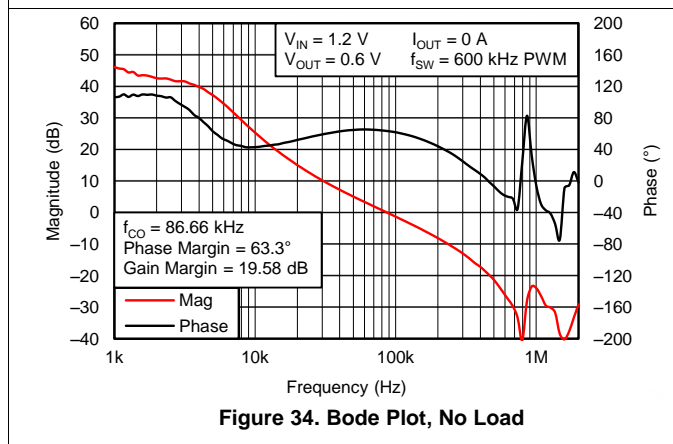

Figure 34. Bode Plot, No Load

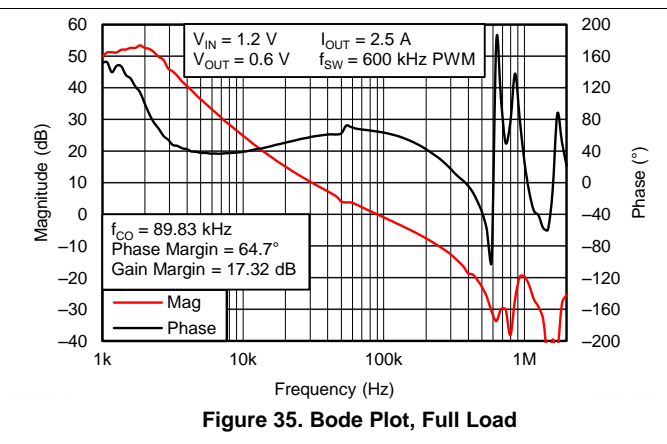
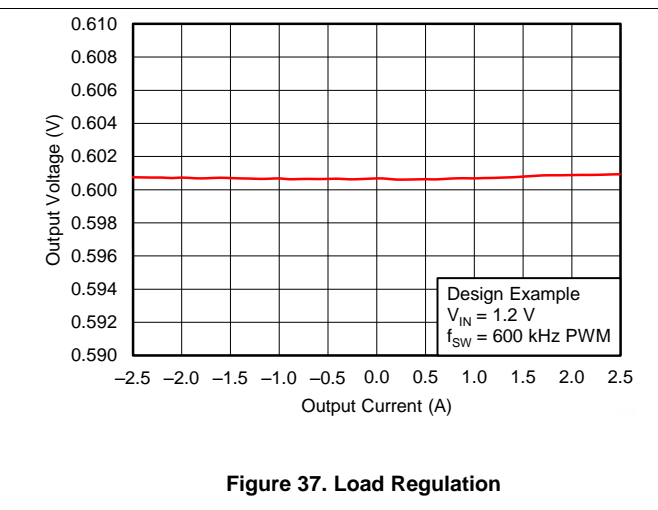
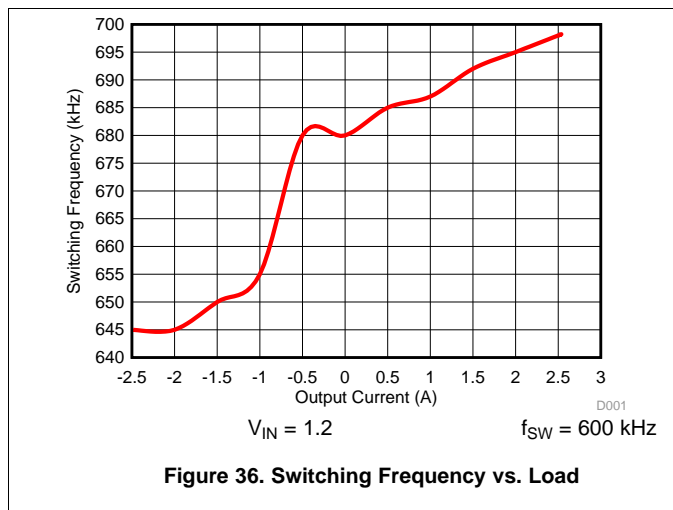

Figure 35. Bode Plot, Full Load

Typical Applications (continued)



8.2.2 DDR3 SDRAM Application

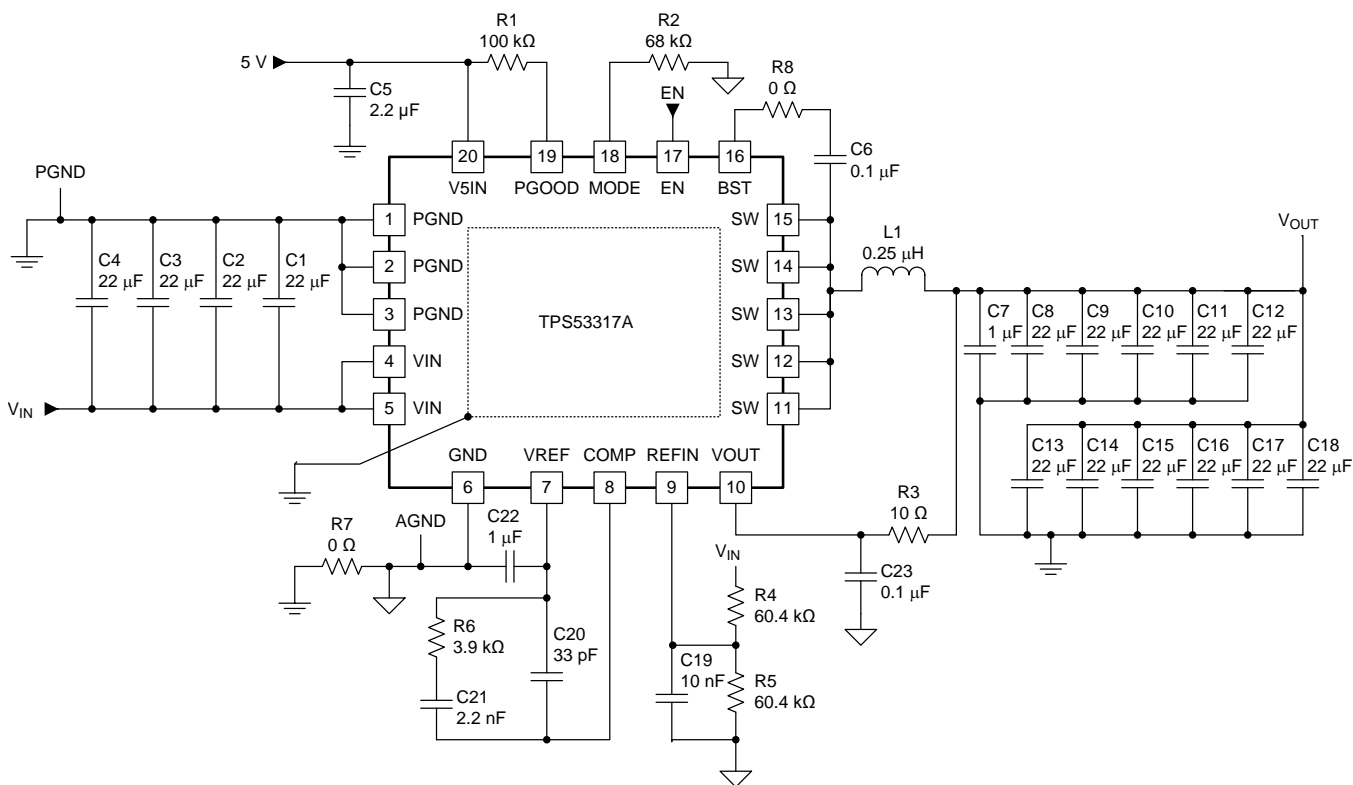

Figure 38. Typical Application Schematic, DDR3

8.2.2.1 Design Requirements

- $V_{IN} = 1.5\text{ V}$
- $V_{OUT} = 0.75\text{ V}$

Typical Applications (continued)

8.2.3 Non-Tracking Point-of-Load (POL) Application

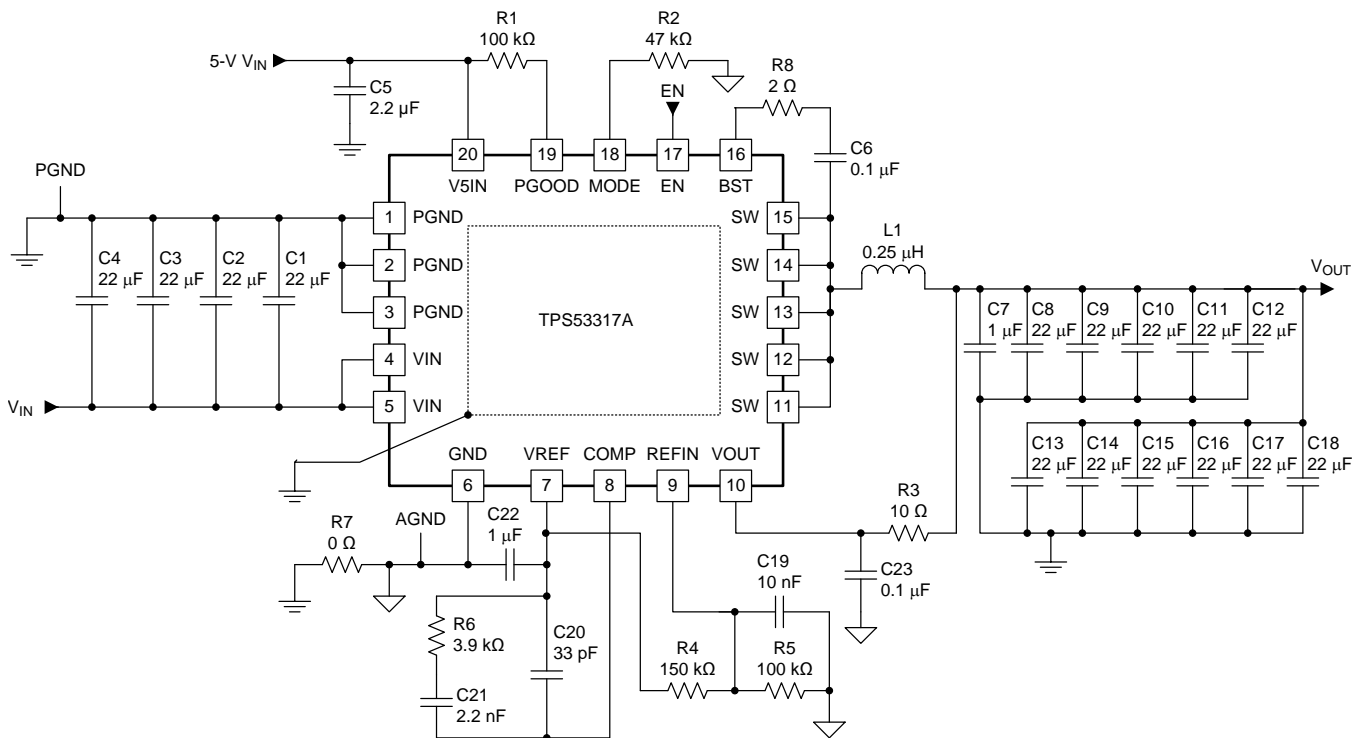

Figure 39. Typical Application Schematic, Non-Tracking Point-of-Load (POL)

8.2.3.1 Design Requirements

- $V_{IN} = 3.3\text{ V}$
- $V_{OUT} = 1.2\text{ V}$

8.2.3.2 Application Curves

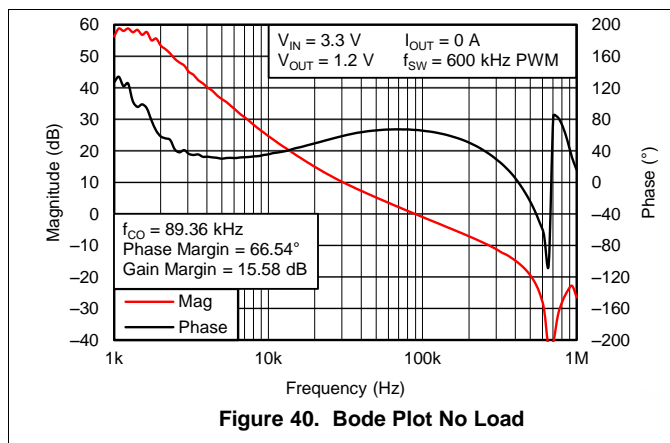

Figure 40. Bode Plot No Load

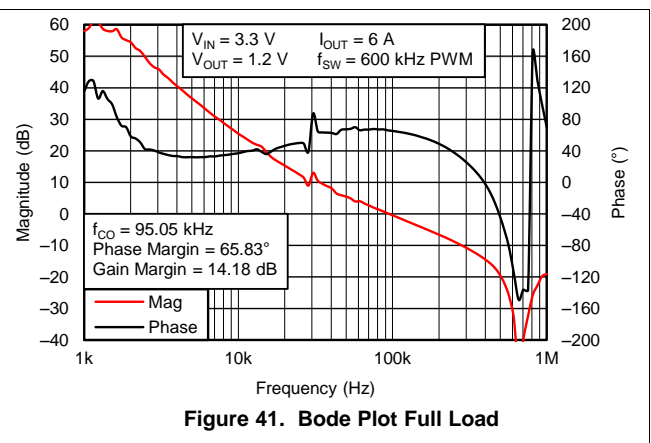

Figure 41. Bode Plot Full Load

9 Power Supply Recommendations

This device operates from an input voltage supply between 0.9 V and 6 V. This device requires a separate 5-V power supply for analog circuits and gate drive. Use the proper bypass capacitors for both the input supply and the 5-V supply in order to filter noise and to ensure proper device operation.

10 Layout

10.1 Layout Guidelines

Stable power supply operation depends on proper layout. Follow these guidelines for an optimized PCB layout.

- Connect PGND pins to the thermal pad underneath the device. Use four vias to connect the thermal pad to internal ground planes.
- Place VIN, V5IN and VREF decoupling capacitors as close to the device as possible.
- Use wide traces for the VIN, PGND and SW pins. These nodes carry high current and also serve as heat sinks.
- Place feedback and compensation components as close to the device as possible.
- Place COMP and VOUT analog signal traces away from noisy signals (SW, BST).
- The GND pin should connect to the PGND in only one place, through a via or a 0-Ω resistor.

10.2 Layout Example

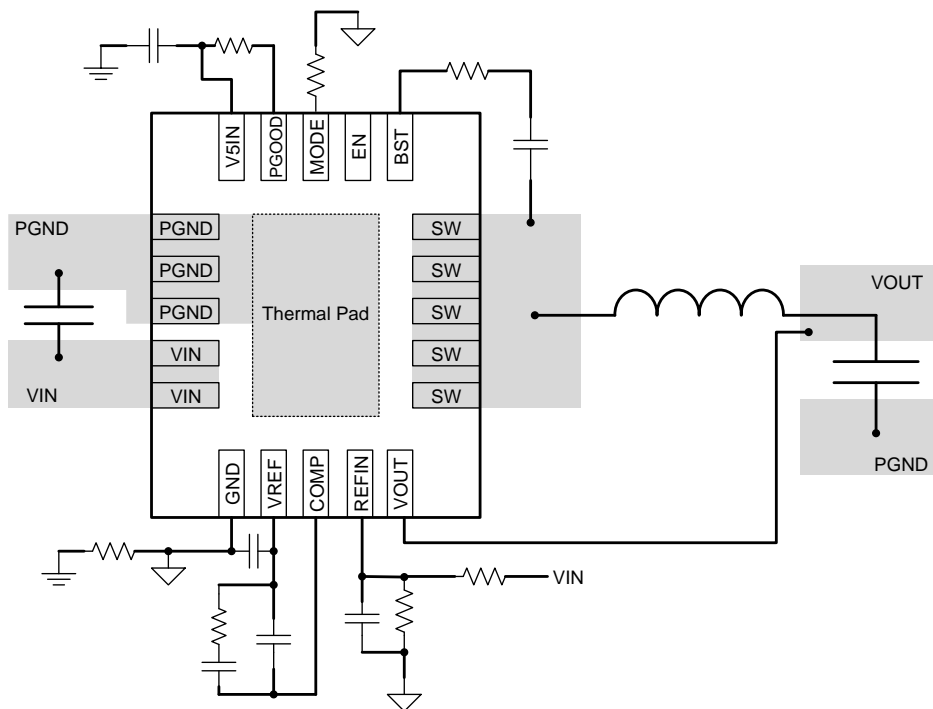

Figure 42. TPS53317A Board Layout

10.3 Mounting and Thermal Profile Recommendation

Proper mounting technique adequately covers the exposed thermal tab with solder. Excessive heat during the reflow process can affect electrical performance. Figure 43 shows the recommended reflow oven thermal profile. Proper post-assembly cleaning is also critical to device performance. See SLUA271 for more information.

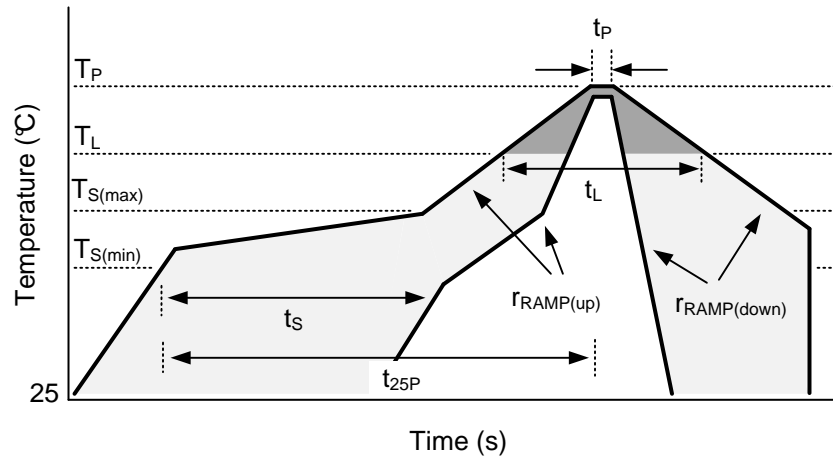

Figure 43. Recommended Reflow Oven Thermal Profile

Table 2. Recommended Thermal Profile Parameters

PARAMETER		MIN	TYP	MAX	UNIT
RAMP UP AND RAMP DOWN					
$r_{RAMP(up)}$	Average ramp-up rate, $T_{S(max)}$ to T_P		3		°C/s
$r_{RAMP(down)}$	Average ramp-down rate, T_P to $T_{S(max)}$		6		°C/s
PRE-HEAT					
T_S	Pre-Heat temperature	150	200		°C
t_s	Pre-heat time, $T_{S(min)}$ to $T_{S(max)}$	60	180		s
REFLOW					
T_L	Liquidus temperature		217		°C
T_P	Peak temperature			260	°C
t_L	Time maintained above liquidus temperature, T_L	60	150		s
t_p	Time maintained within 5 °C of peak temperature, T_P	20	40		s
t_{25P}	Total time from 25 °C to peak temperature, T_P			480	s

11 Device and Documentation Support

11.1 Community Resources

The following links connect to TI community resources. Linked contents are provided "AS IS" by the respective contributors. They do not constitute TI specifications and do not necessarily reflect TI's views; see TI's [Terms of Use](#).

TI E2E™ Online Community *TI's Engineer-to-Engineer (E2E) Community*. Created to foster collaboration among engineers. At e2e.ti.com, you can ask questions, share knowledge, explore ideas and help solve problems with fellow engineers.

Design Support *TI's Design Support* Quickly find helpful E2E forums along with design support tools and contact information for technical support.

11.2 Trademarks

D-CAP+, E2E are trademarks of Texas Instruments.
All other trademarks are the property of their respective owners.

11.3 Electrostatic Discharge Caution



These devices have limited built-in ESD protection. The leads should be shorted together or the device placed in conductive foam during storage or handling to prevent electrostatic damage to the MOS gates.

11.4 Glossary

[SLYZ022](#) — *TI Glossary*.

This glossary lists and explains terms, acronyms, and definitions.

12 Mechanical, Packaging, and Orderable Information

The following pages include mechanical, packaging, and orderable information. This information is the most current data available for the designated devices. This data is subject to change without notice and revision of this document. For browser-based versions of this data sheet, refer to the left-hand navigation.

PACKAGING INFORMATION

Orderable Device	Status (1)	Package Type	Package Drawing	Pins	Package Qty	Eco Plan (2)	Lead/Ball Finish (6)	MSL Peak Temp (3)	Op Temp (°C)	Device Marking (4/5)	Samples
TPS53317ARGBR	ACTIVE	VQFN	RGB	20	3000	Green (RoHS & no Sb/Br)	CU NIPDAU	Level-2-260C-1 YEAR	-40 to 125	53317A	Samples
TPS53317ARGBT	ACTIVE	VQFN	RGB	20	250	Green (RoHS & no Sb/Br)	CU NIPDAU	Level-2-260C-1 YEAR	-40 to 125	53317A	Samples

(1) The marketing status values are defined as follows:

ACTIVE: Product device recommended for new designs.

LIFEBUY: TI has announced that the device will be discontinued, and a lifetime-buy period is in effect.

NRND: Not recommended for new designs. Device is in production to support existing customers, but TI does not recommend using this part in a new design.

PREVIEW: Device has been announced but is not in production. Samples may or may not be available.

OBSOLETE: TI has discontinued the production of the device.

(2) Eco Plan - The planned eco-friendly classification: Pb-Free (RoHS), Pb-Free (RoHS Exempt), or Green (RoHS & no Sb/Br) - please check <http://www.ti.com/productcontent> for the latest availability information and additional product content details.

TBD: The Pb-Free/Green conversion plan has not been defined.

Pb-Free (RoHS): TI's terms "Lead-Free" or "Pb-Free" mean semiconductor products that are compatible with the current RoHS requirements for all 6 substances, including the requirement that lead not exceed 0.1% by weight in homogeneous materials. Where designed to be soldered at high temperatures, TI Pb-Free products are suitable for use in specified lead-free processes.

Pb-Free (RoHS Exempt): This component has a RoHS exemption for either 1) lead-based flip-chip solder bumps used between the die and package, or 2) lead-based die adhesive used between the die and leadframe. The component is otherwise considered Pb-Free (RoHS compatible) as defined above.

Green (RoHS & no Sb/Br): TI defines "Green" to mean Pb-Free (RoHS compatible), and free of Bromine (Br) and Antimony (Sb) based flame retardants (Br or Sb do not exceed 0.1% by weight in homogeneous material)

(3) MSL, Peak Temp. - The Moisture Sensitivity Level rating according to the JEDEC industry standard classifications, and peak solder temperature.

(4) There may be additional marking, which relates to the logo, the lot trace code information, or the environmental category on the device.

(5) Multiple Device Markings will be inside parentheses. Only one Device Marking contained in parentheses and separated by a "~" will appear on a device. If a line is indented then it is a continuation of the previous line and the two combined represent the entire Device Marking for that device.

(6) Lead/Ball Finish - Orderable Devices may have multiple material finish options. Finish options are separated by a vertical ruled line. Lead/Ball Finish values may wrap to two lines if the finish value exceeds the maximum column width.

Important Information and Disclaimer: The information provided on this page represents TI's knowledge and belief as of the date that it is provided. TI bases its knowledge and belief on information provided by third parties, and makes no representation or warranty as to the accuracy of such information. Efforts are underway to better integrate information from third parties. TI has taken and continues to take reasonable steps to provide representative and accurate information but may not have conducted destructive testing or chemical analysis on incoming materials and chemicals. TI and TI suppliers consider certain information to be proprietary, and thus CAS numbers and other limited information may not be available for release.

In no event shall TI's liability arising out of such information exceed the total purchase price of the TI part(s) at issue in this document sold by TI to Customer on an annual basis.

RGB (R-PVQFN-N20)

PLASTIC QUAD FLATPACK NO-LEAD

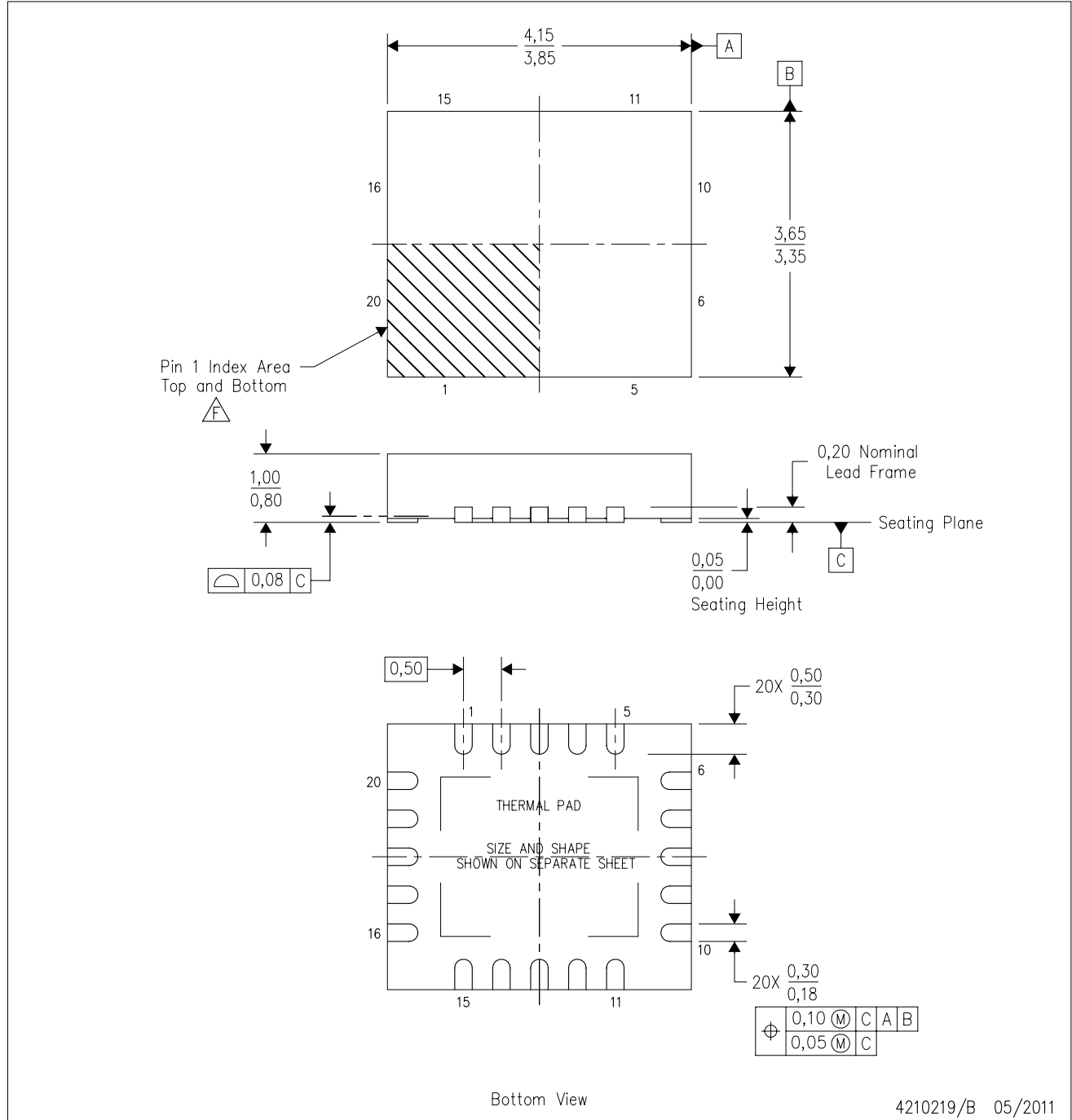

- NOTES:
- A. All linear dimensions are in millimeters. Dimensioning and tolerancing per ASME Y14.5M-1994.
 - B. This drawing is subject to change without notice.
 - C. QFN (Quad Flatpack No-Lead) package configuration.
 - D. The package thermal pad must be soldered to the board for thermal and mechanical performance.
 - E. See the additional figure in the Product Data Sheet for details regarding the exposed thermal pad features and dimensions.
-  Pin 1 identifiers are located on both top and bottom of the package and within the zone indicated. The Pin 1 identifiers are either a molded, marked, or metal feature.

THERMAL PAD MECHANICAL DATA

RGB (R-PVQFN-N20)

PLASTIC QUAD FLATPACK NO-LEAD

THERMAL INFORMATION

This package incorporates an exposed thermal pad that is designed to be attached directly to an external heatsink. The thermal pad must be soldered directly to the printed circuit board (PCB). After soldering, the PCB can be used as a heatsink. In addition, through the use of thermal vias, the thermal pad can be attached directly to the appropriate copper plane shown in the electrical schematic for the device, or alternatively, can be attached to a special heatsink structure designed into the PCB. This design optimizes the heat transfer from the integrated circuit (IC).

For information on the Quad Flatpack No-Lead (QFN) package and its advantages, refer to Application Report, QFN/SON PCB Attachment, Texas Instruments Literature No. SLUA271. This document is available at www.ti.com.

The exposed thermal pad dimensions for this package are shown in the following illustration.

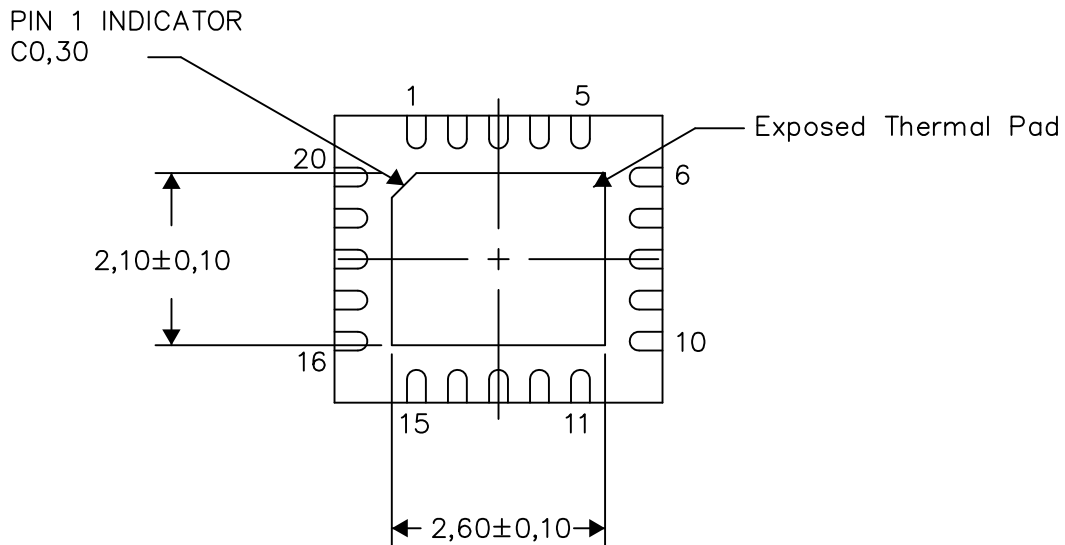

Bottom View

Exposed Thermal Pad Dimensions

4210242/C 05/12

NOTE: All linear dimensions are in millimeters

RGB (R-PVQFN-N20)

PLASTIC QUAD FLATPACK NO-LEAD

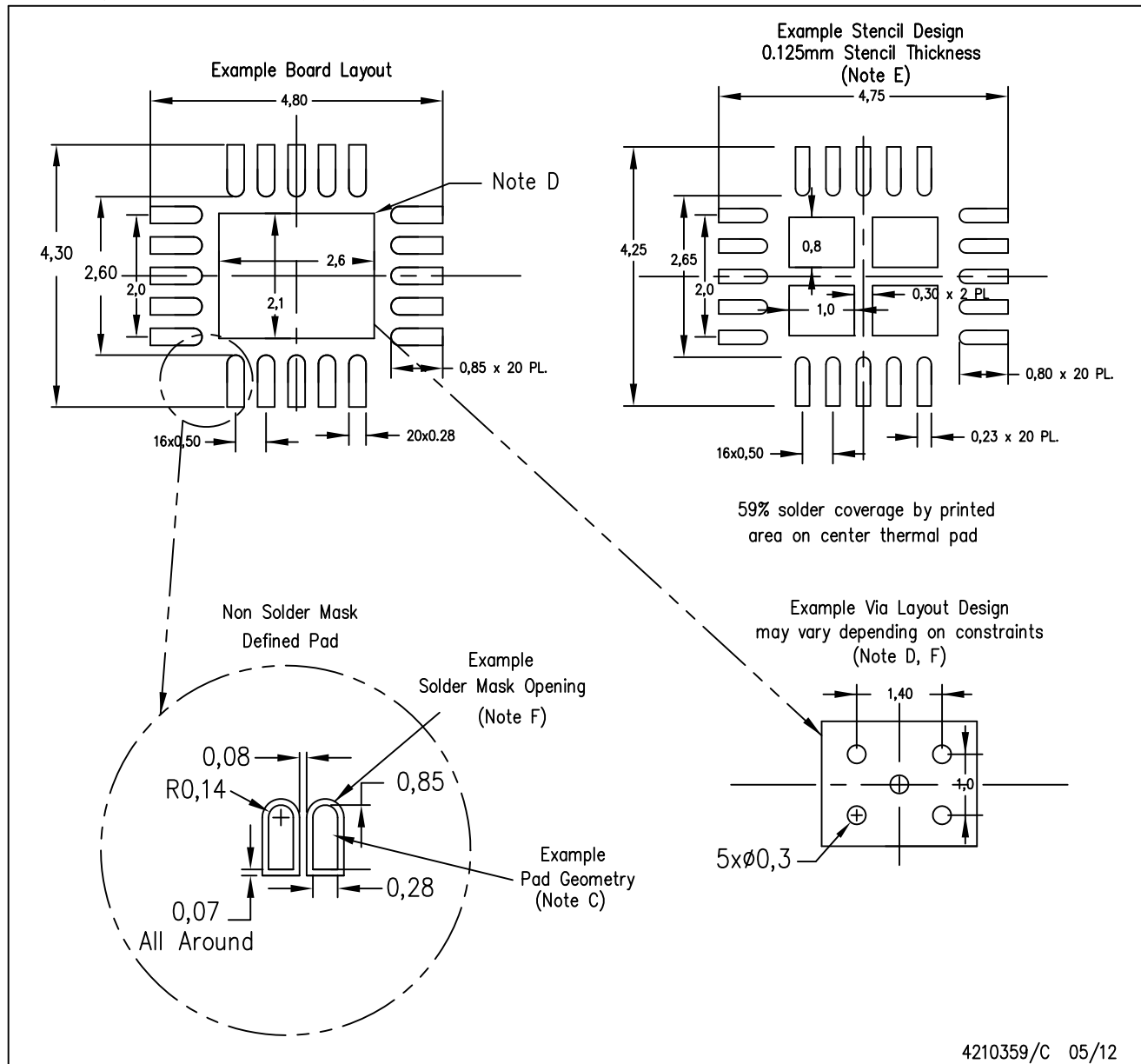

- NOTES:
- A. All linear dimensions are in millimeters.
 - B. This drawing is subject to change without notice.
 - C. Publication IPC-7351 is recommended for alternate designs.
 - D. This package is designed to be soldered to a thermal pad on the board. Refer to Application Note, Quad Flat-Pack QFN/SON PCB Attachment, Texas Instruments Literature No. SLUA271, and also the Product Data Sheets for specific thermal information, via requirements, and recommended board layout. These documents are available at www.ti.com <<http://www.ti.com>>.
 - E. Laser cutting apertures with trapezoidal walls and also rounding corners will offer better paste release. Customers should contact their board assembly site for stencil design recommendations. Refer to IPC 7525 for stencil design considerations.
 - F. Customers should contact their board fabrication site for minimum solder mask web tolerances between signal pads.

IMPORTANT NOTICE

Texas Instruments Incorporated and its subsidiaries (TI) reserve the right to make corrections, enhancements, improvements and other changes to its semiconductor products and services per JESD46, latest issue, and to discontinue any product or service per JESD48, latest issue. Buyers should obtain the latest relevant information before placing orders and should verify that such information is current and complete. All semiconductor products (also referred to herein as "components") are sold subject to TI's terms and conditions of sale supplied at the time of order acknowledgment.

TI warrants performance of its components to the specifications applicable at the time of sale, in accordance with the warranty in TI's terms and conditions of sale of semiconductor products. Testing and other quality control techniques are used to the extent TI deems necessary to support this warranty. Except where mandated by applicable law, testing of all parameters of each component is not necessarily performed.

TI assumes no liability for applications assistance or the design of Buyers' products. Buyers are responsible for their products and applications using TI components. To minimize the risks associated with Buyers' products and applications, Buyers should provide adequate design and operating safeguards.

TI does not warrant or represent that any license, either express or implied, is granted under any patent right, copyright, mask work right, or other intellectual property right relating to any combination, machine, or process in which TI components or services are used. Information published by TI regarding third-party products or services does not constitute a license to use such products or services or a warranty or endorsement thereof. Use of such information may require a license from a third party under the patents or other intellectual property of the third party, or a license from TI under the patents or other intellectual property of TI.

Reproduction of significant portions of TI information in TI data books or data sheets is permissible only if reproduction is without alteration and is accompanied by all associated warranties, conditions, limitations, and notices. TI is not responsible or liable for such altered documentation. Information of third parties may be subject to additional restrictions.

Resale of TI components or services with statements different from or beyond the parameters stated by TI for that component or service voids all express and any implied warranties for the associated TI component or service and is an unfair and deceptive business practice. TI is not responsible or liable for any such statements.

Buyer acknowledges and agrees that it is solely responsible for compliance with all legal, regulatory and safety-related requirements concerning its products, and any use of TI components in its applications, notwithstanding any applications-related information or support that may be provided by TI. Buyer represents and agrees that it has all the necessary expertise to create and implement safeguards which anticipate dangerous consequences of failures, monitor failures and their consequences, lessen the likelihood of failures that might cause harm and take appropriate remedial actions. Buyer will fully indemnify TI and its representatives against any damages arising out of the use of any TI components in safety-critical applications.

In some cases, TI components may be promoted specifically to facilitate safety-related applications. With such components, TI's goal is to help enable customers to design and create their own end-product solutions that meet applicable functional safety standards and requirements. Nonetheless, such components are subject to these terms.

No TI components are authorized for use in FDA Class III (or similar life-critical medical equipment) unless authorized officers of the parties have executed a special agreement specifically governing such use.

Only those TI components which TI has specifically designated as military grade or "enhanced plastic" are designed and intended for use in military/aerospace applications or environments. Buyer acknowledges and agrees that any military or aerospace use of TI components which have **not** been so designated is solely at the Buyer's risk, and that Buyer is solely responsible for compliance with all legal and regulatory requirements in connection with such use.

TI has specifically designated certain components as meeting ISO/TS16949 requirements, mainly for automotive use. In any case of use of non-designated products, TI will not be responsible for any failure to meet ISO/TS16949.

Products

Audio	www.ti.com/audio
Amplifiers	amplifier.ti.com
Data Converters	dataconverter.ti.com
DLP® Products	www.dlp.com
DSP	dsp.ti.com
Clocks and Timers	www.ti.com/clocks
Interface	interface.ti.com
Logic	logic.ti.com
Power Mgmt	power.ti.com
Microcontrollers	microcontroller.ti.com
RFID	www.ti-rfid.com
OMAP Applications Processors	www.ti.com/omap
Wireless Connectivity	www.ti.com/wirelessconnectivity

Applications

Automotive and Transportation	www.ti.com/automotive
Communications and Telecom	www.ti.com/communications
Computers and Peripherals	www.ti.com/computers
Consumer Electronics	www.ti.com/consumer-apps
Energy and Lighting	www.ti.com/energy
Industrial	www.ti.com/industrial
Medical	www.ti.com/medical
Security	www.ti.com/security
Space, Avionics and Defense	www.ti.com/space-avionics-defense
Video and Imaging	www.ti.com/video

TI E2E Community

e2e.ti.com

Looking for pricing, stock, or lifecycle information?

Click below to explore more details on WIN SOURCE:

 [View TPS53317ARGBT on WIN SOURCE](#)

 [Texas Instruments](#) Information

Optimize Your Supply Chain with WIN SOURCE Solutions

-  Global Sourcing Solution
-  Obsolete Management
-  Cost Control Management
-  Shortage Management
-  Alternative Solution
-  Excess Inventory Management