



THE DATASHEET OF SSF3341



Main Product Characteristics

V_{DSS}	-30V
$R_{DS(on)}$	42m Ω (typ.)
I_D	-4.2A ①

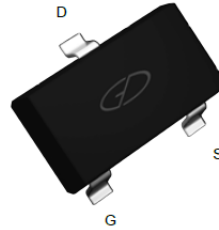

SOT-23

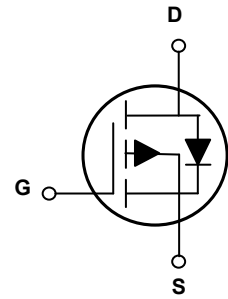

Schematic Diagram

Features and Benefits

- Advanced MOSFET process technology
- Ideal for PWM, load switching and general purpose applications
- Ultra low on-resistance with low gate charge
- Fast switching and reverse body recovery
- 150°C operating temperature



Description

The SSF3341 utilizes the latest processing techniques to achieve high cell density, low on-resistance and high repetitive avalanche rating. These features make this device extremely efficient and reliable for use in power switching applications and a wide variety of other applications.

Absolute Max Ratings (T_A=25°C unless otherwise specified)

Symbol	Parameter	Max.	Units
$I_D @ T_C = 25^\circ\text{C}$	Continuous Drain Current, $V_{GS} @ 10\text{V}$	-4.2 ①	A
$I_D @ T_C = 70^\circ\text{C}$	Continuous Drain Current, $V_{GS} @ 10\text{V}$	-3.5 ①	
I_{DM}	Pulsed Drain Current ②	-30	
$P_D @ T_C = 25^\circ\text{C}$	Power Dissipation ③	1.4	W
V_{DS}	Drain-Source Voltage	-30	V
V_{GS}	Gate-to-Source Voltage	± 12	V
$T_J \quad T_{STG}$	Operating Junction and Storage Temperature Range	-55 to +150	°C

Thermal Resistance

Symbol	Characteristics	Typ.	Max.	Units
$R_{\theta JA}$	Junction-to-ambient (t ≤ 10s) ④	—	90	°C/W

Electrical Characteristics ($T_A=25^\circ\text{C}$ unless otherwise specified)

Symbol	Parameter	Min.	Typ.	Max.	Units	Conditions
$V_{(BR)DSS}$	Drain-to-Source Breakdown Voltage	-30	—	—	V	$V_{GS} = 0V, I_D = -250\mu A$
$R_{DS(on)}$	Static Drain-to-Source On-resistance	—	42	50	m Ω	$V_{GS}=-10V, I_D = -4.2A$
		—	51	65		$V_{GS}=-4.5V, I_D = -4A$
		—	72	120		$V_{GS}=-2.5V, I_D = -1A$
$V_{GS(th)}$	Gate Threshold Voltage	-0.7	—	-1.3	V	$V_{DS} = V_{GS}, I_D = -250\mu A$
		—	-0.68	—		$T_J = 125^\circ\text{C}$
I_{DSS}	Drain-to-Source Leakage Current	—	—	-1	μA	$V_{DS} = -24V, V_{GS} = 0V$
		—	—	-50		$T_J = 125^\circ\text{C}$
I_{GSS}	Gate-to-Source Forward Leakage	—	—	100	nA	$V_{GS} = 12V$
		—	—	-100		$V_{GS} = -12V$
Q_g	Total Gate Charge	—	18	—	nC	$I_D = -4A,$ $V_{DS}=-25V,$ $V_{GS} = -10V$
Q_{gs}	Gate-to-Source Charge	—	2.1	—		
Q_{gd}	Gate-to-Drain("Miller") Charge	—	2.7	—		
$t_{d(on)}$	Turn-on Delay Time	—	7.5	—	ns	$V_{GS}=-10V, V_{DS}=-15V,$ $R_{GEN}=3\Omega,$
t_r	Rise Time	—	15	—		
$t_{d(off)}$	Turn-Off Delay Time	—	26	—		
t_f	Fall Time	—	3.7	—		
C_{iss}	Input Capacitance	—	712	—	pF	$V_{GS} = 0V,$ $V_{DS} = -15V,$ $f = 1\text{MHz}$
C_{oss}	Output Capacitance	—	82	—		
C_{rss}	Reverse Transfer Capacitance	—	67	—		

Source-Drain Ratings and Characteristics

Symbol	Parameter	Min.	Typ.	Max.	Units	Conditions
I_S	Continuous Source Current (Body Diode)	—	—	-4.2 ①	A	MOSFET symbol showing the integral reverse p-n junction diode.
I_{SM}	Pulsed Source Current (Body Diode)	—	—	-30	A	
V_{SD}	Diode Forward Voltage	—	-0.78	-1.0	V	$I_S=-1A, V_{GS}=0V$

Test Circuits and Waveforms

EAS Test Circuit:

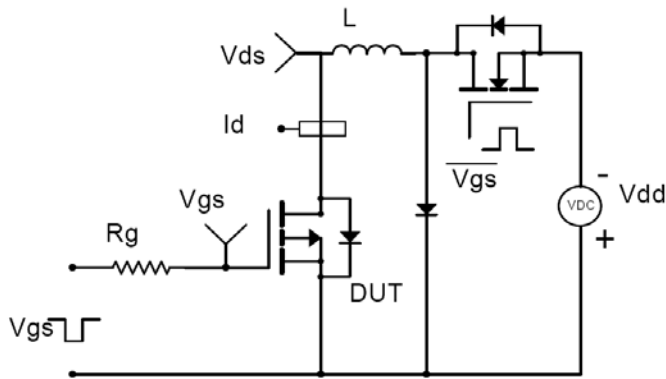

Gate Charge Test Circuit:

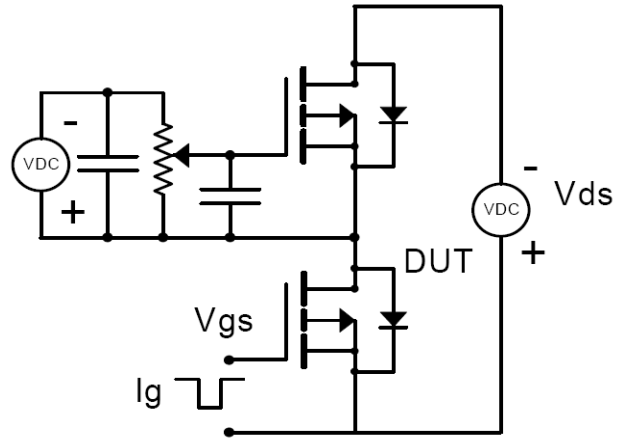

Switching Time Test Circuit:

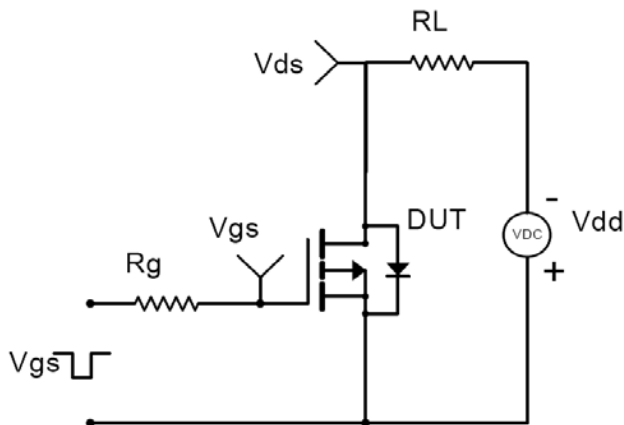

Switch Waveforms:

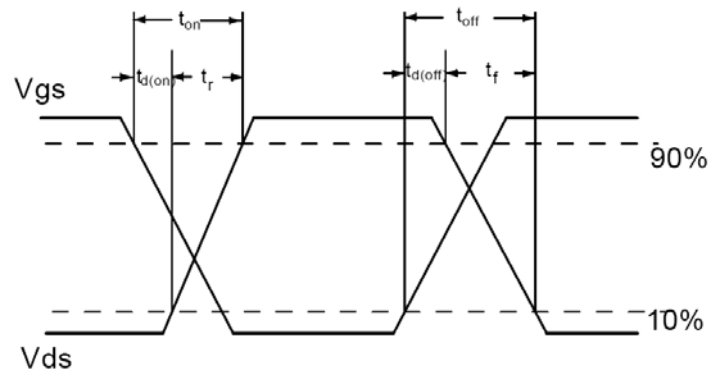

Notes:

- ① Calculated continuous current based on maximum allowable junction temperature.
- ② Repetitive rating; pulse width limited by max. junction temperature.
- ③ The power dissipation P_D is based on max. junction temperature, using junction-to-case thermal resistance.
- ④ The value of $R_{\theta JA}$ is measured with the device mounted on 1 in² FR-4 board with 2oz. Copper, in a still air environment with $T_A = 25^\circ\text{C}$.

Typical Electrical and Thermal Characteristics

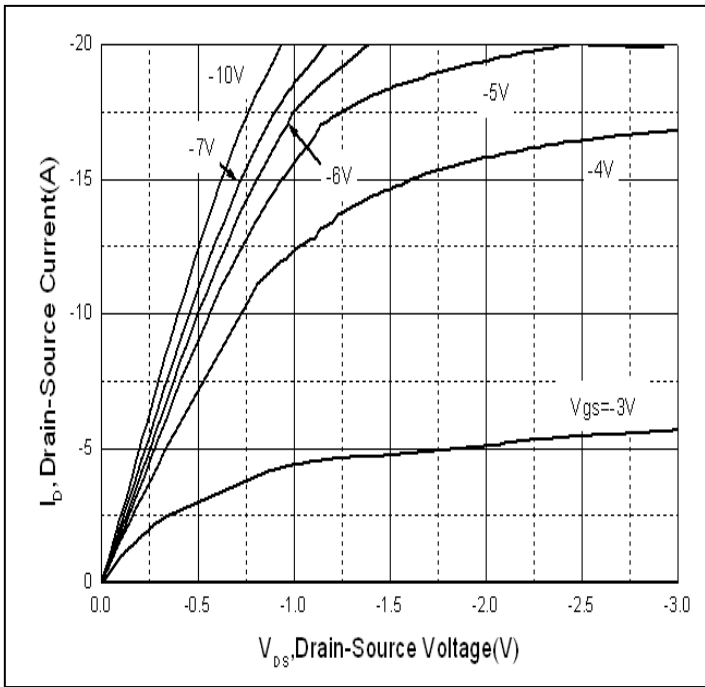

Figure 1. Typical Output Characteristics

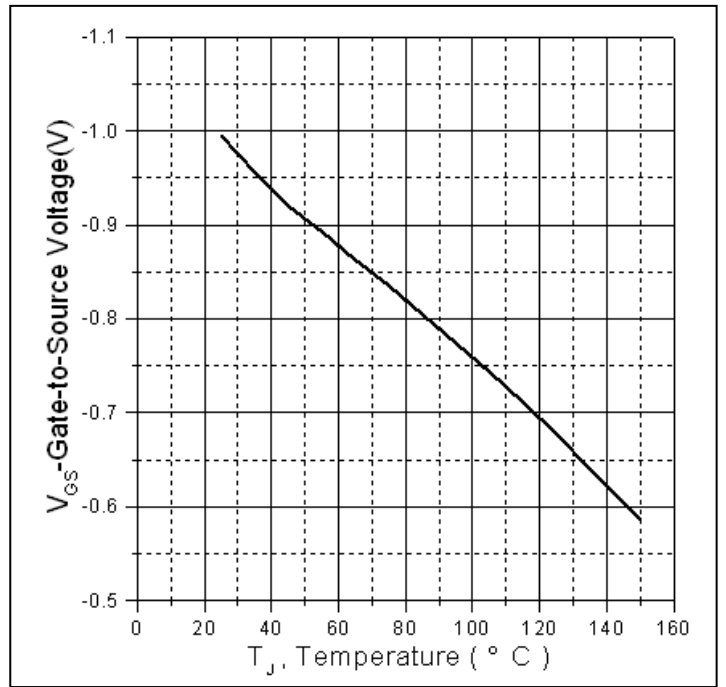

Figure 2. Gate to Source Cut-off Voltage

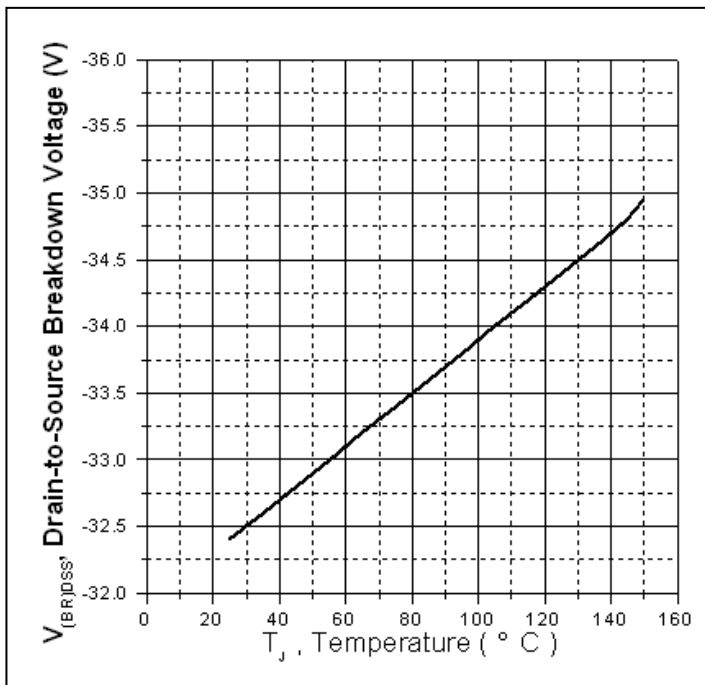

Figure 3. Drain-to-Source Breakdown Voltage Vs. Case Temperature

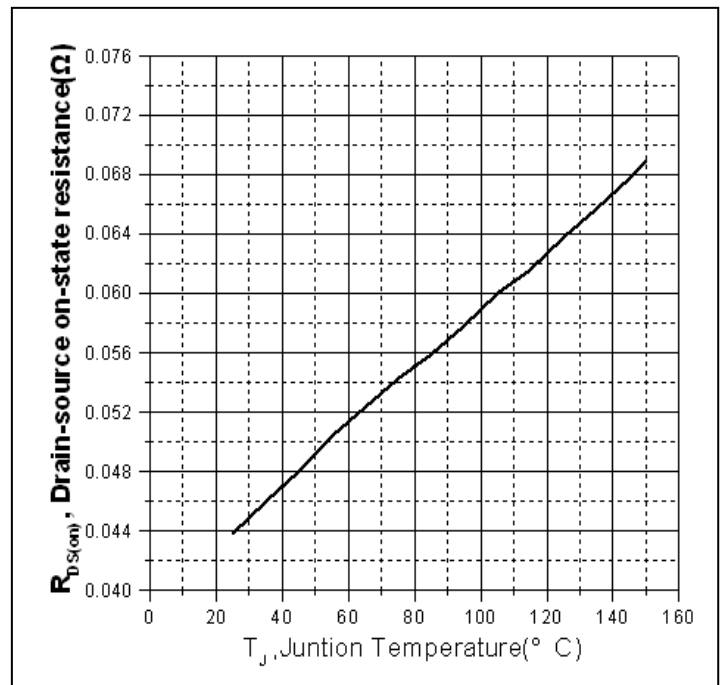

Figure 4. Normalized On-Resistance Vs. Case Temperature

Typical Electrical and Thermal Characteristics

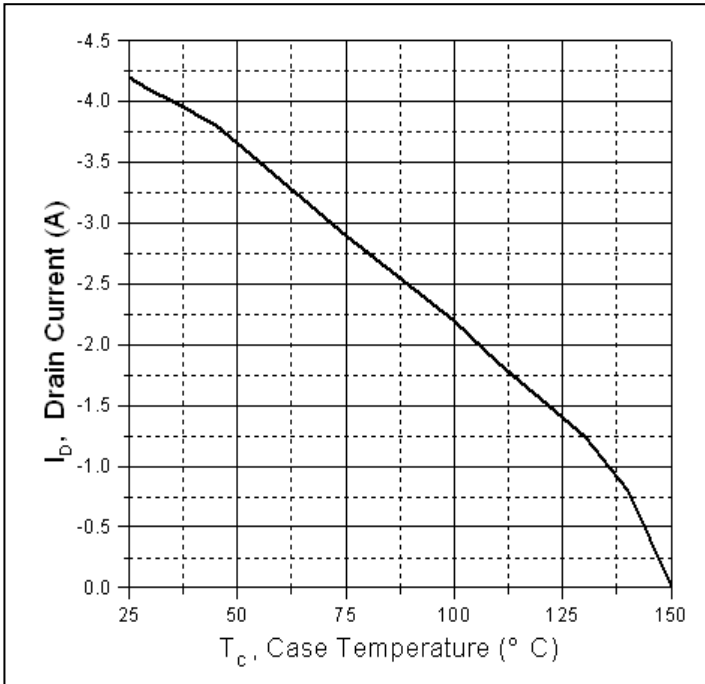

Figure 5. Maximum Drain Current Vs. Case Temperature

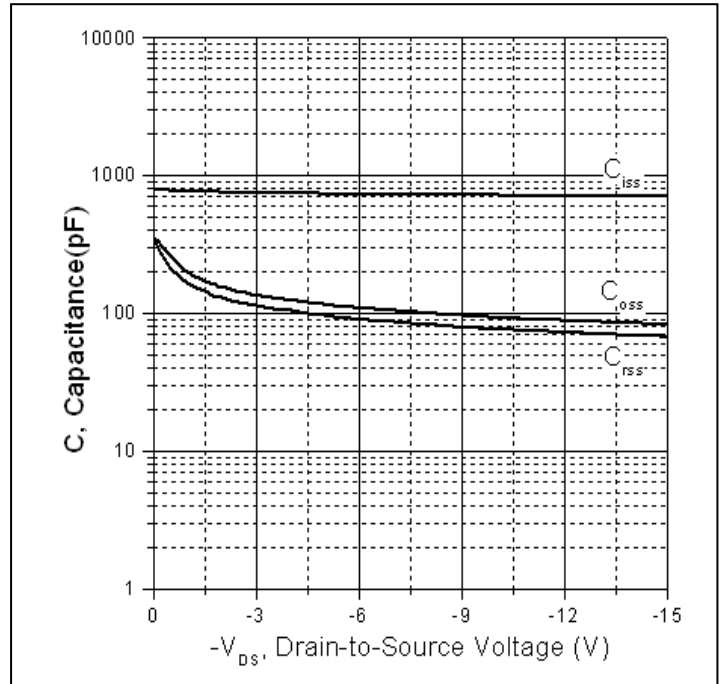

Figure 6. Typical Capacitance Vs. Drain-to-Source Voltage

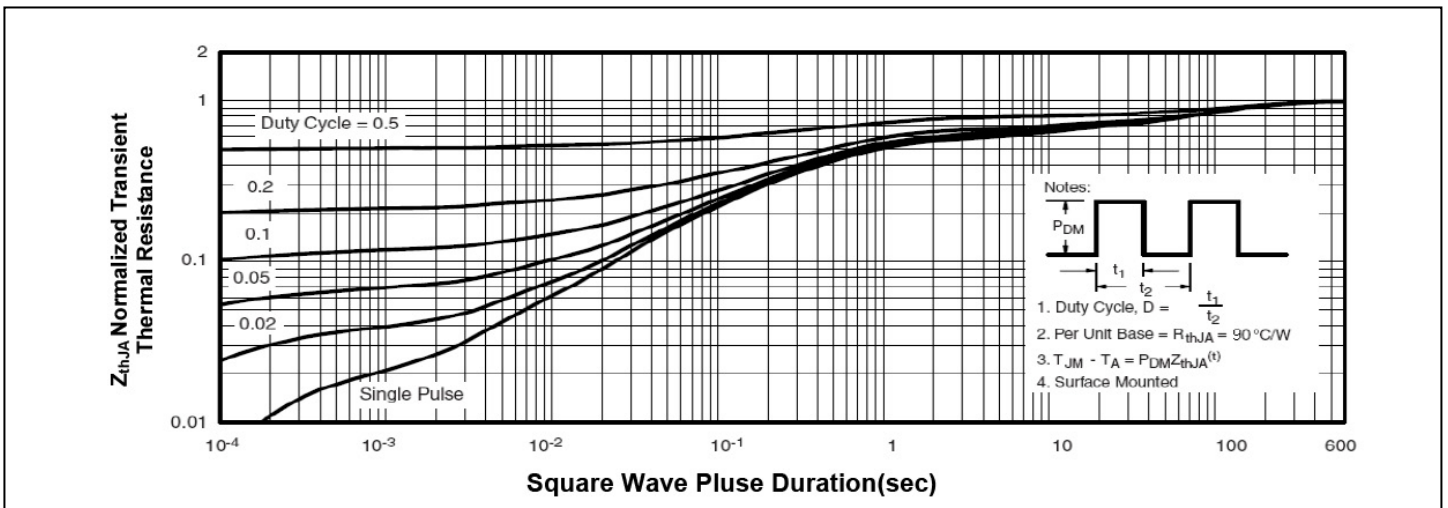
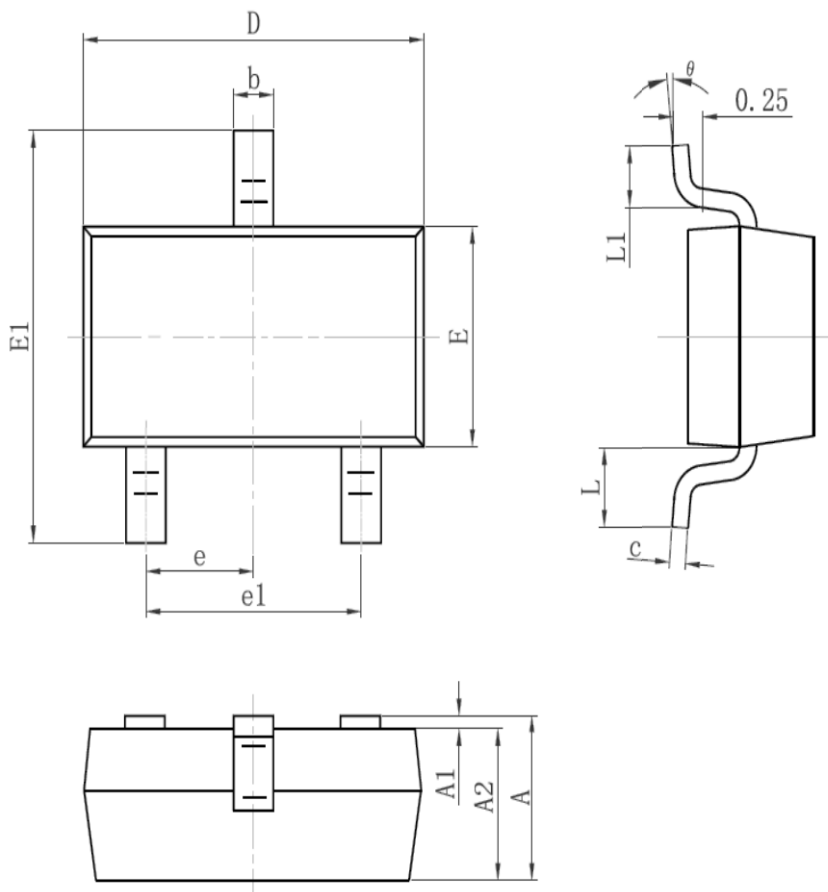

Figure 7. Maximum Effective Transient Thermal Impedance Junction-to-Case

Mechanical Data

SOT-23 PACKAGE OUTLINE DIMENSION



Symbol	Dimension In Millimeters		Dimension In Inches	
	Min	Max	Min	Max
A	0.900	1.150	0.035	0.045
A1	0.000	0.100	0.000	0.004
A2	0.900	1.050	0.035	0.041
b	0.300	0.500	0.012	0.020
c	0.080	0.150	0.003	0.006
D	2.800	3.000	0.110	0.118
E	1.200	1.400	0.047	0.055
E1	2.250	2.550	0.089	0.100
e	0.95TYP		0.037TYP	
e1	1.800	2.000	0.071	0.079
L	0.55REF		0.022REF	
L1	0.300	0.500	0.012	0.020
θ	0°	8°	0°	8°

Ordering and Marking Information

<p>Device Marking: 3341</p> <p>Package (Available) SOT-23</p> <p>Operating Temperature Range C : -55 to 150 °C</p>

Devices per Unit



Package Type	Units/ Tape	Tapes/ Inner Box	Units/ Inner Box	Inner Boxes/ Carton Box	Units/ Carton Box
SOT23	3000	10	30000	4	120000

Reliability Test Program







Test Item	Conditions	Duration	Sample Size
High Temperature Reverse Bias(HTRB)	T _j =125°C to 150°C @ 80% of Max V _{DSS} /V _{CES} /V _R	168 hours 500 hours 1000 hours	3 lots x 77 devices
High Temperature Gate Bias(HTGB)	T _j =150°C @ 100% of Max V _{GSS}	168 hours 500 hours 1000 hours	3 lots x 77 devices

Looking for pricing, stock, or lifecycle information?

Click below to explore more details on WIN SOURCE:

-  [View SSF3341](#) on WIN SOURCE
-  [GOOD-ARK Electronics](#) Information

Optimize Your Supply Chain with WIN SOURCE Solutions

-  Global Sourcing Solution
-  Obsolete Management
-  Cost Control Management
-  Shortage Management
-  Alternative Solution
-  Excess Inventory Management