



THE DATASHEET OF SSF2341E



Main Product Characteristics

V_{DSS}	-20V
$R_{DS(ON)}$	37m Ω (typ.)
I_D	-4A ①

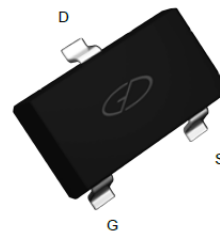

SOT-23

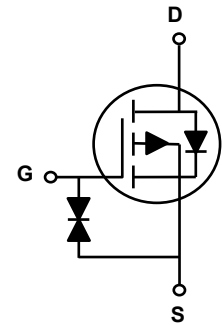

Schematic Diagram

Features and Benefit

- Advanced MOSFET process technology
- Ideal for PWM, load switching and general purpose applications
- Ultra low on-resistance with low gate charge
- Fast switching and reverse body recovery
- 150°C operating temperature



Description

The SSF2341E utilizes the latest techniques to achieve high cell density and low on-resistance. These features make this device extremely efficient and reliable for use in high efficiency switch mode power supply and a wide variety of other applications.

Absolute Max Ratings (T_A=25°C unless otherwise specified)

Symbol	Parameter	Max.	Unit
$I_D @ T_C = 25^\circ\text{C}$	Continuous Drain Current, $V_{GS} @ 10\text{V}$	-4 ①	A
$I_D @ T_C = 70^\circ\text{C}$	Continuous Drain Current, $V_{GS} @ 10\text{V}$	-2.4 ①	
I_{DM}	Pulsed Drain Current ②	-30	
$P_D @ T_C = 25^\circ\text{C}$	Power Dissipation ③	1.4	W
V_{DS}	Drain-Source Voltage	-20	V
V_{GS}	Gate-to-Source Voltage	± 8	V
$T_J \quad T_{STG}$	Operating Junction and Storage Temperature Range	-55 to +150	°C

Thermal Resistance

Symbol	Characteristics	Typ.	Max.	Unit
$R_{\theta JA}$	Junction-to-ambient (t ≤ 10s) ④	—	90	°C/W

Electrical Characteristics ($T_A=25^\circ\text{C}$ unless otherwise specified)

Symbol	Parameter	Min.	Typ.	Max.	Unit	Conditions
$V_{(BR)DSS}$	Drain-to-Source Breakdown Voltage	-20	—	—	V	$V_{GS} = 0V, I_D = -250\mu A$
$R_{DS(on)}$	Static Drain-to-Source On-resistance	—	37	43	m Ω	$V_{GS}=-4.5V, I_D = -4A$
		—	45	54		$V_{GS}=-2.5V, I_D = -4A$
		—	56	73		$V_{GS}=-1.8V, I_D = -2A$
$V_{GS(th)}$	Gate Threshold Voltage	-0.3	—	-1.0	V	$V_{DS} = V_{GS}, I_D = -250\mu A$
		—	-0.44	—		$T_J=125^\circ\text{C}$
I_{DSS}	Drain-to-Source Leakage Current	—	—	-1	μA	$V_{DS} = -16V, V_{GS} = 0V$
		—	—	-50		$T_J=125^\circ\text{C}$
I_{GSS}	Gate-to-Source Forward Leakage	—	—	10	μA	$V_{GS} = 8V$
		—	—	-10		$V_{GS} = -8V$
Q_g	Total Gate Charge	—	10	—	nC	$I_D = -4A,$ $V_{DS}=-10V$ $V_{GS} = -4.5V$
Q_{gs}	Gate-to-Source Charge	—	0.77	—		
Q_{gd}	Gate-to-Drain("Miller") Charge	—	3.5	—		
$t_{d(on)}$	Turn-on Delay Time	—	10	—	nS	$V_{GS}=-4.5V, V_{DS} = -10V,$ $R_{GEN}=3\Omega,$
t_r	Rise Time	—	8.6	—		
$t_{d(off)}$	Turn-Off Delay Time	—	29	—		
t_f	Fall Time	—	13	—		
C_{iss}	Input Capacitance	—	939	—	pF	$V_{GS} = 0V$ $V_{DS} = -10V$ $f = 1\text{MHz}$
C_{oss}	Output Capacitance	—	130	—		
C_{rss}	Reverse Transfer Capacitance	—	111	—		

Source-Drain Ratings and Characteristics

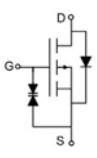
Symbol	Parameter	Min.	Typ.	Max.	Units	Conditions
I_S	Continuous Source Current (Body Diode)	—	—	-4 ①	A	MOSFET symbol showing the integral reverse p-n junction diode. 
I_{SM}	Pulsed Source Current (Body Diode)	—	—	-30	A	
V_{SD}	Diode Forward Voltage	—	-0.76	-1.0	V	$I_S=1A, V_{GS}=0V$
t_{rr}	Reverse Recovery Time	—	8.7	—	ns	$T_J = 25^\circ\text{C}, I_F = -4A$
Q_{rr}	Reverse Recovery Charge	—	2.3	—	nC	$di/dt = 100A/\mu s$

Test Circuits and Waveforms

E_{AS} Test Circuit:

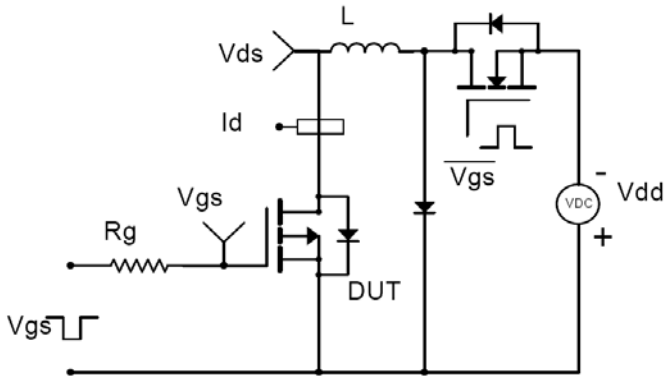

Gate Charge Test Circuit:

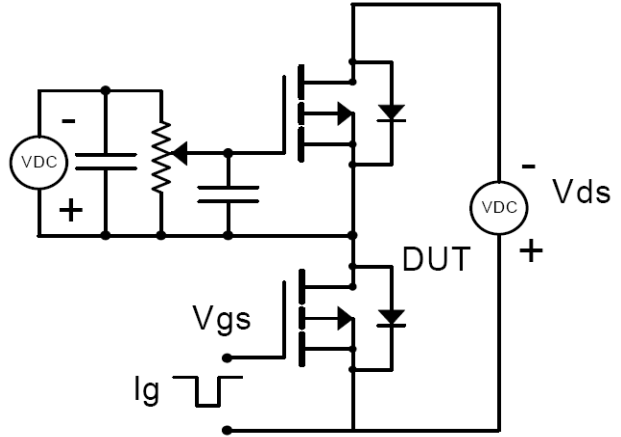

Switching Time Test Circuit:

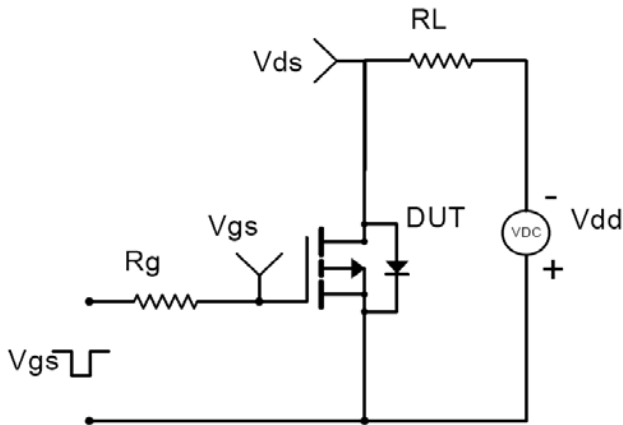

Switching Waveforms:

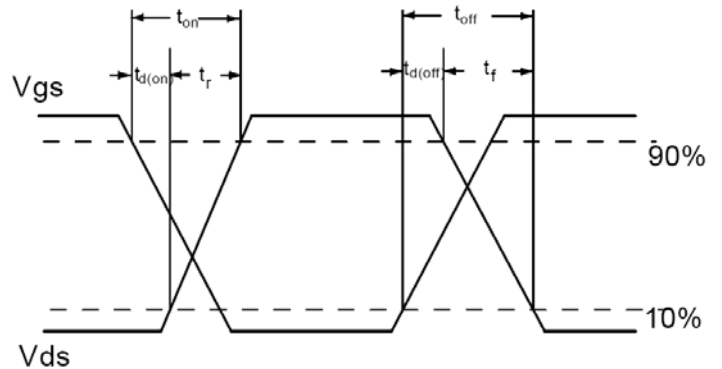

Notes:

- ① Calculated continuous current based on maximum allowable junction temperature.
- ② Repetitive rating; pulse width limited by max. junction temperature.
- ③ The power dissipation P_D is based on max. junction temperature, using junction-to-case thermal resistance.
- ④ The value of R_{θJA} is measured with the device mounted on 1 in² FR-4 board with 2oz. Copper, in a still air environment with T_A = 25°C

Typical Electrical and Thermal Characteristics

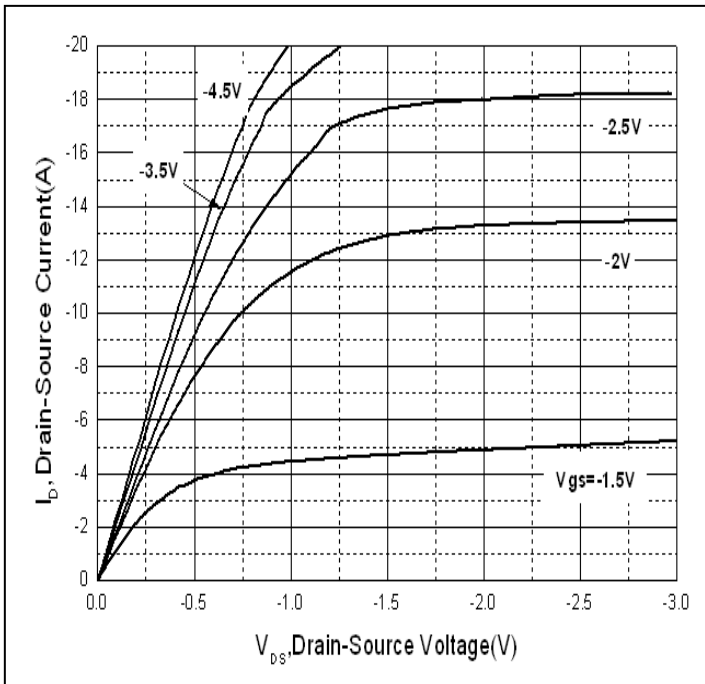

Figure 1. Typical Output Characteristics

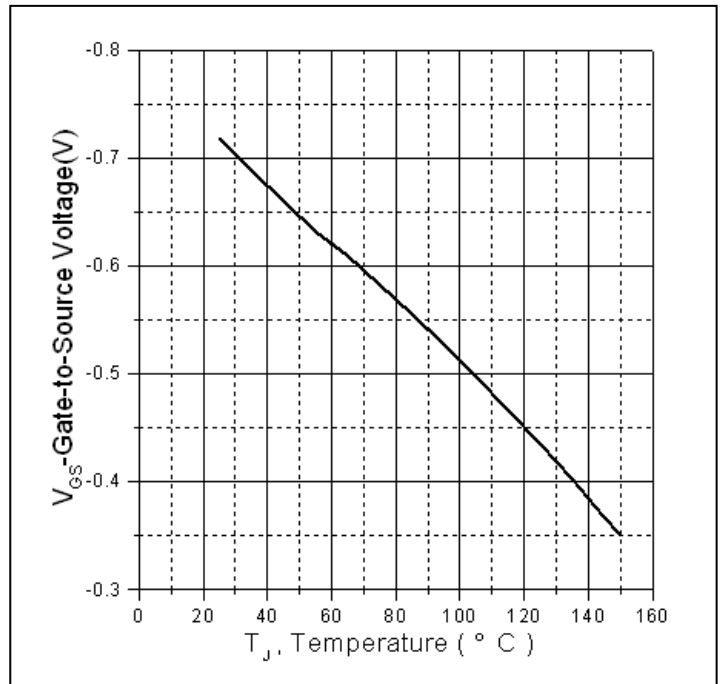

Figure 2. Gate to Source Cut-off Voltage

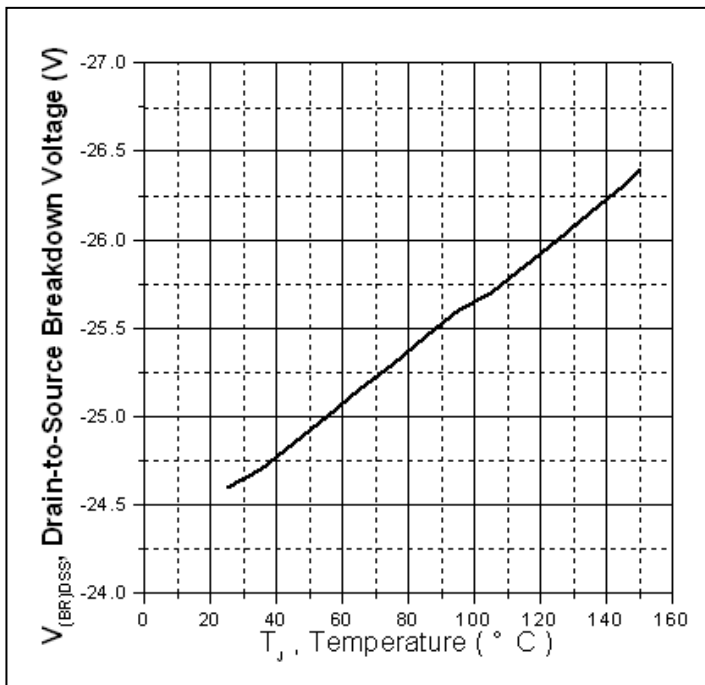

Figure 3. Drain-to-Source Breakdown Voltage Vs. Case Temperature

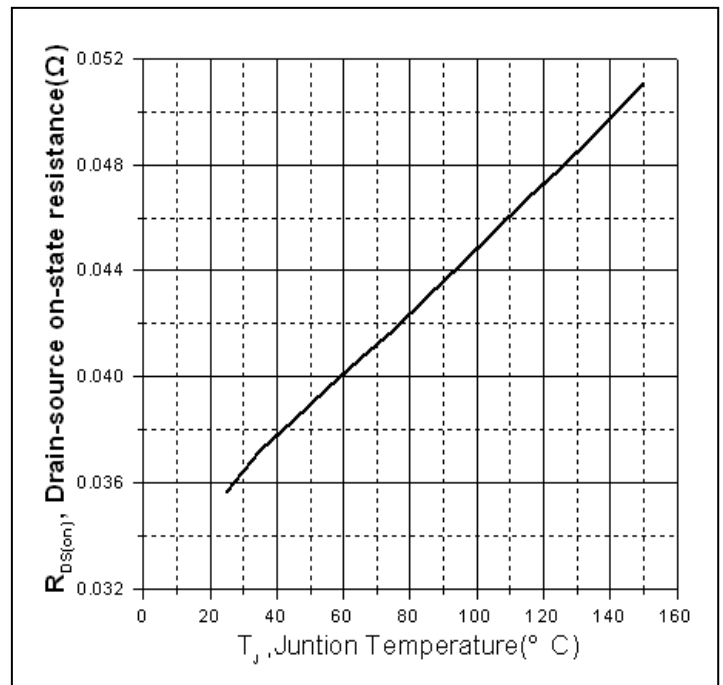

Figure 4. Normalized On-Resistance Vs. Case Temperature

Typical Electrical and Thermal Characteristics

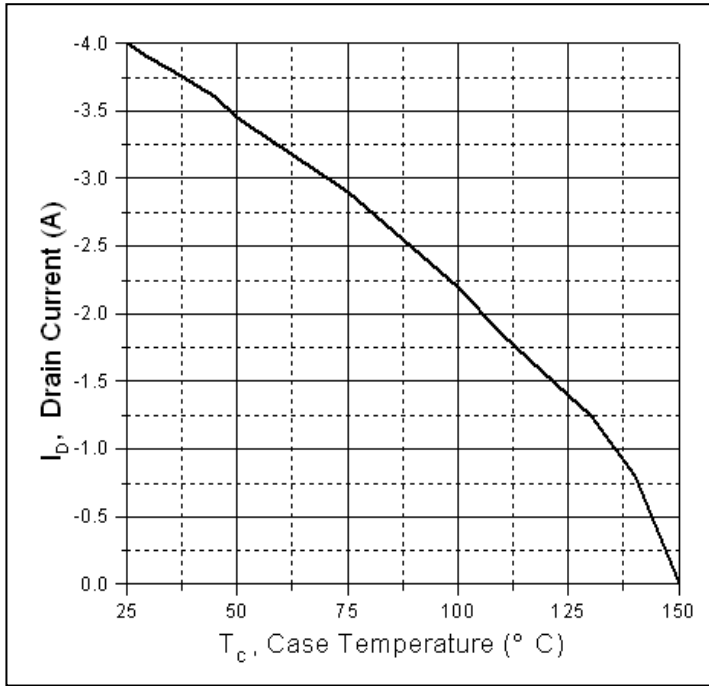

Figure 5. Maximum Drain Current Vs. Case Temperature

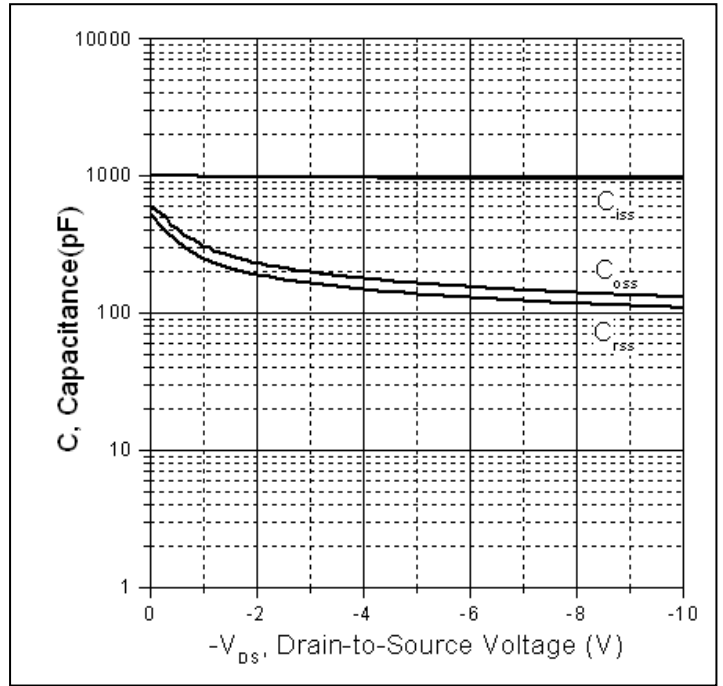

Figure 6. Typical Capacitance Vs. Drain-to-Source Voltage

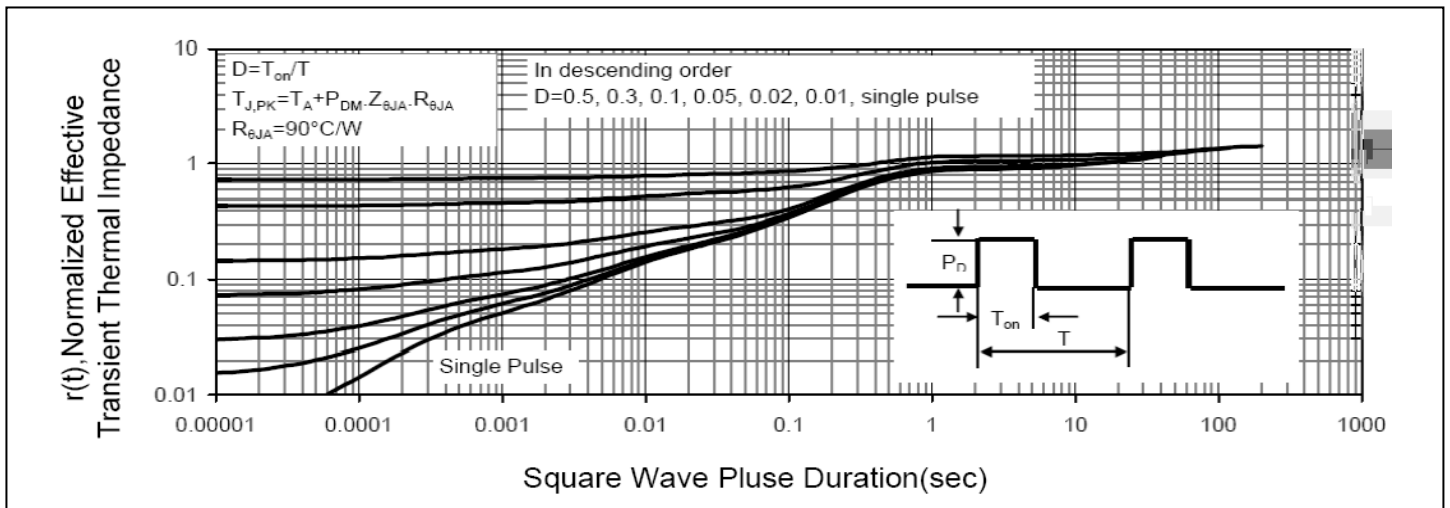
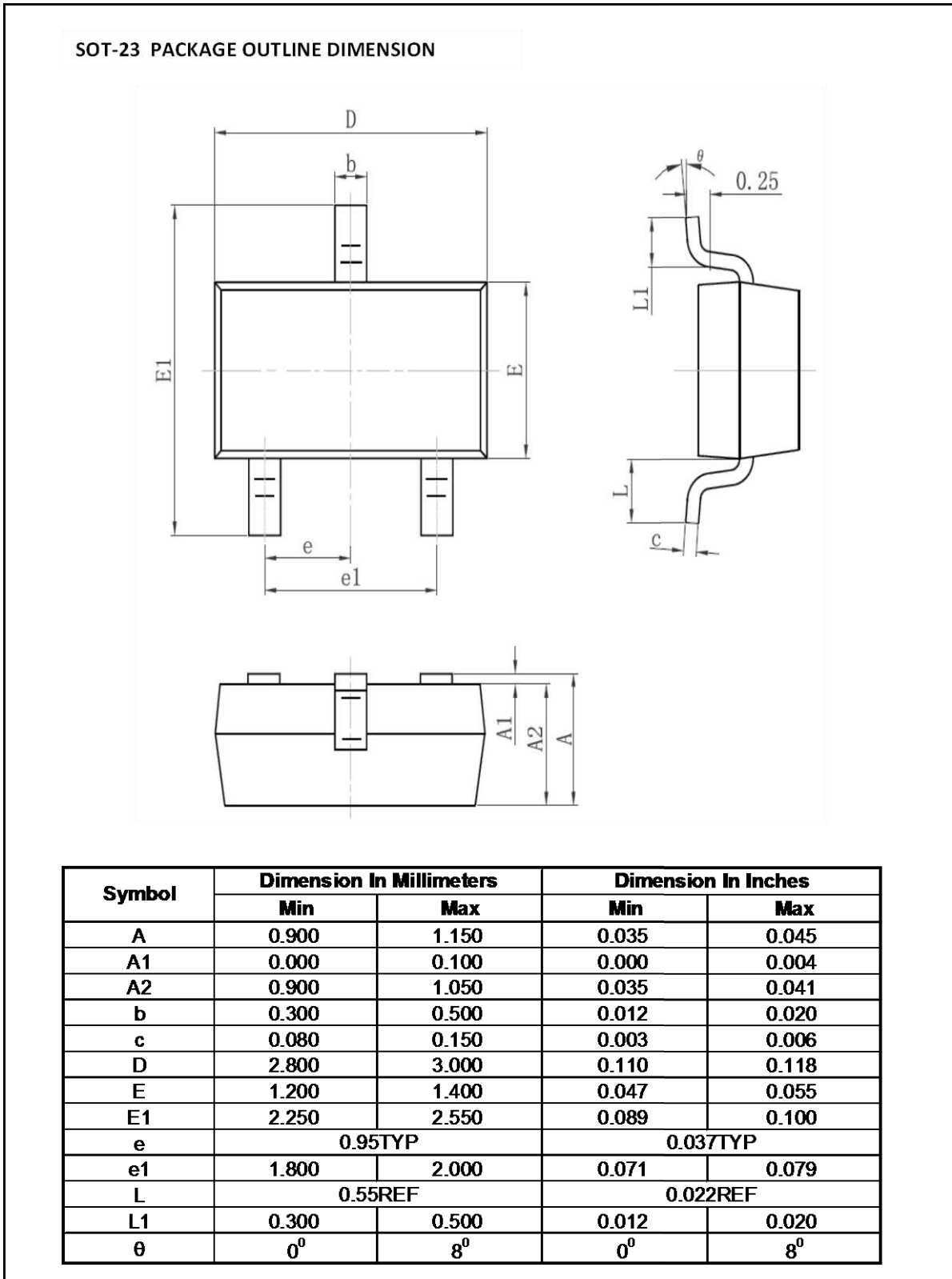

Figure 7. Maximum Effective Transient Thermal Impedance Junction-to-Case

Mechanical Data





Ordering and Marking Information

Device Marking: 2341E

Package (Available)
SOT-23
Operating Temperature Range
C : -55 to 150 °C

Devices per Unit



Package Type	Units/ Tape	Tapes/ Inner Box	Units/ Inner Box	Inner Boxes/ Carton Box	Units/ Carton Box
SOT23	3000	10	30000	4	120000

Reliability Test Program







Test Item	Conditions	Duration	Sample Size
High Temperature Reverse Bias(HTRB)	$T_j=125^{\circ}\text{C}$ to 150°C @ 80% of Max $V_{DSS}/V_{CES}/V_R$	168 hours 500 hours 1000 hours	3 lots x 77 devices
High Temperature Gate Bias(HTGB)	$T_j=150^{\circ}\text{C}$ @ 100% of Max V_{GSS}	168 hours 500 hours 1000 hours	3 lots x 77 devices

Looking for pricing, stock, or lifecycle information?

Click below to explore more details on WIN SOURCE:

-  [View SSF2341E on WIN SOURCE](#)
-  [GOOD-ARK Electronics Information](#)

Optimize Your Supply Chain with WIN SOURCE Solutions

-  Global Sourcing Solution
-  Obsolete Management
-  Cost Control Management
-  Shortage Management
-  Alternative Solution
-  Excess Inventory Management