



THE DATASHEET OF SEN013DG



SEN012-013 SENZero Family

Zero¹ Loss High Voltage Sense Signal Disconnect IC

Product Highlights

Features and Performance

- Eliminates significant standby losses
 - Disconnects unnecessary circuit blocks during standby, remote-off, or light-load conditions
- Ultra low leakage (maximum 1 μ A) 650 V MOSFETs
 - <0.5 mW per channel during standby
- Single component provides remote disconnect functionality
 - No external components or additional bias supply needed for remote-off
 - Integrates multiple disconnect MOSFETs, gate drive, and protection
 - Minimal component count provides higher reliability
- Protection features to help production/manufacturing yields
 - Pin-to-pin fault and ESD protection
- Triggerable via remote-off signal or load conditions
 - Integrated gate pull down circuit protects against loss of trigger signal fault
- Green package technology
 - RoHS compliant and halogen free
- Withstands high differential surge conditions
 - S1, S2 and S3 interface with controller pins up to 6.5 V above system ground

EcoSmart™— Energy Efficient

- <3 mW loss at 230 VAC in Off/standby mode

Applications

- ACDC converters with high-voltage resistive signal paths
- Ideal for all very low standby systems such as those meeting EuP Lot 6 and similar energy efficiency standards

Description

SENZero™ is a compact low-cost solution to eliminate losses in resistive signal paths connected between high-voltage rails and switching power supply controller(s). Examples include feed-forward or feedback signal paths connected to boost controllers in power factor corrected systems and feed-forward signal paths in two switch forward / LLC / half and full bridge converters.

The device is available in 2 (SEN012) and 3 (SEN013) channel versions according to the application's requirements. The internal gate drive and protection circuitry provides gate drive signals to the internal 650 V MOSFETs in response to the voltage applied to the VCC pin. This simple configuration provides easy integration into existing systems by using the system V_{CC} rail as an input to the SENZero.

The SENZero family uses a low cost compact SO-8 package to reduce PCB area while the pin configuration is designed to meet pin-pin fault conditions.



Figure 3. SO-8 D Package.

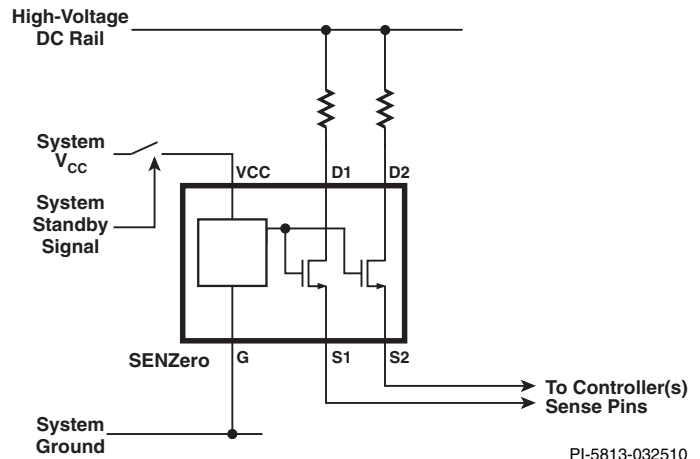

Figure 1. Typical Application SEN012.

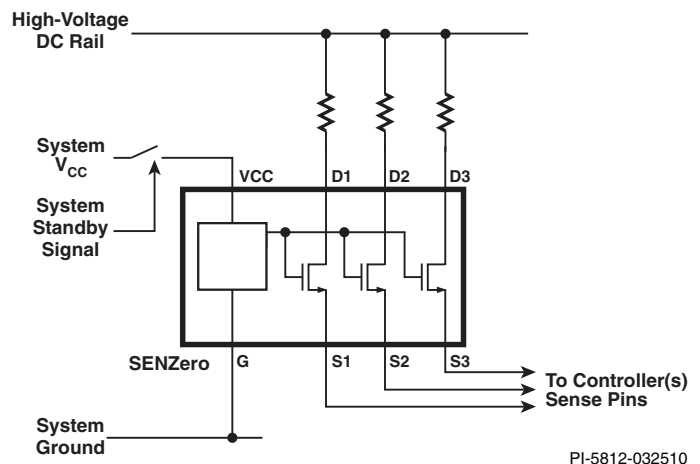

Figure 2. Typical Application SEN013.

Component Selection Table

Product ²	Integrated Disconnect MOSFETs	230 VAC Power Consumption in Standby
SEN012DG	2	<1 mW
SEN013DG	3	<1.5 mW

Table 1. Component Selection Table.

Notes:

1. IEC 16301 clause 4.5 rounds standby power use below 5 mW to zero.
2. Package: D: SO-8.

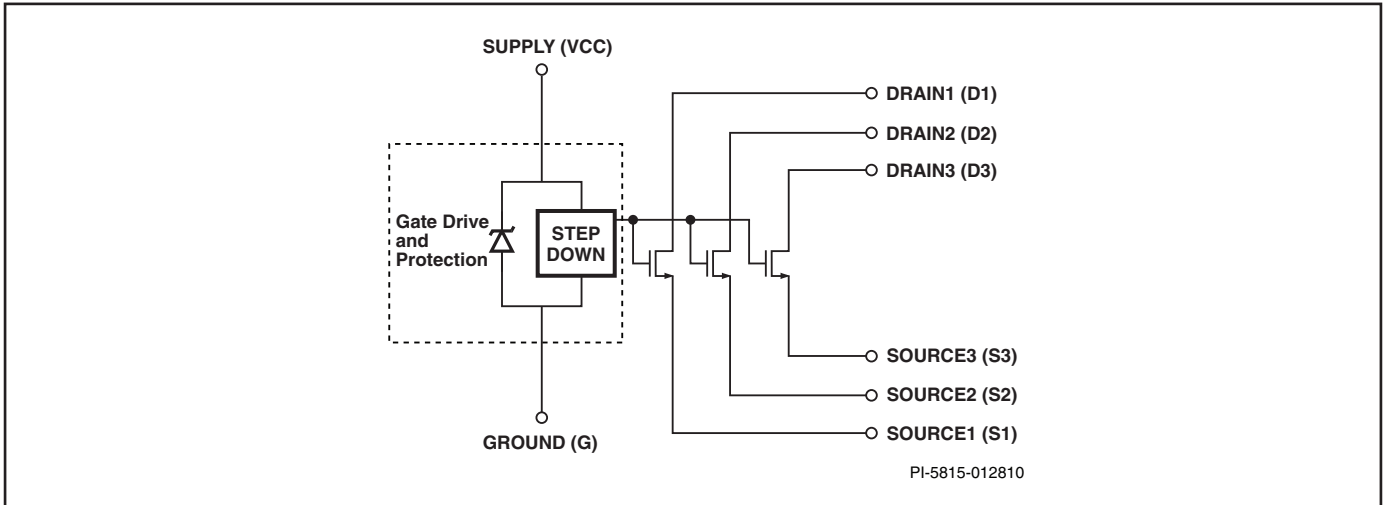

Figure 4. SENZero Functional Block Diagram

Pin Functional Description

SOURCE (S1, S2, S3) Pins:

Internally connect to the SOURCES of MOSFETs 1, 2 and 3 respectively.

DRAIN (D1, D2, D3) Pins:

Internally connect to the DRAINS of MOSFETs 1, 2 and 3 respectively.

VOLTAGE SUPPLY (VCC) Pin:

The internal MOSFETs are fully turned on when the VCC pin voltage is $V_{CC(ON)}$ (see parameter table) or more greater than their SOURCE voltage relative to GROUND. VCC pin should be connected to GROUND to turn the MOSFETs off.

GROUND (G) Pin:

This is the ground reference for all the SENZero pin voltages.

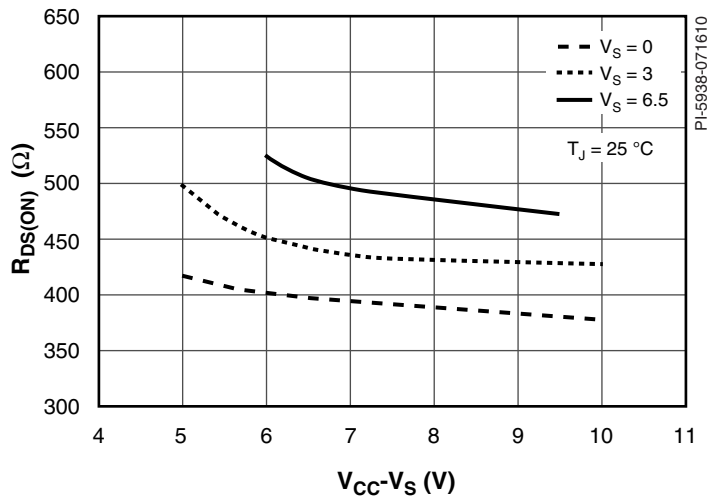

Figure 6. Typical $R_{DS(ON)}$ as a Function of $V_{CC}-V_S$ Voltage.

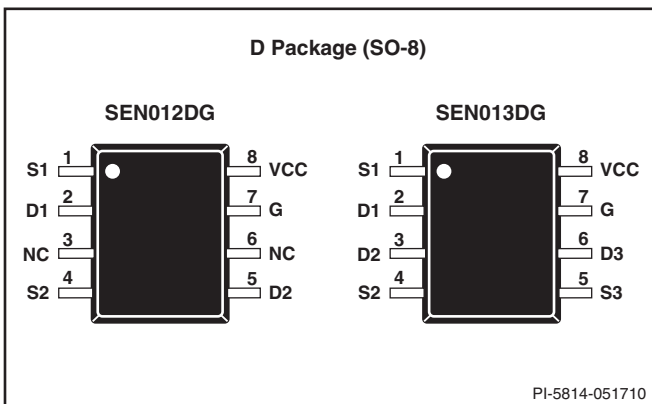

Figure 5. Pin Configuration.

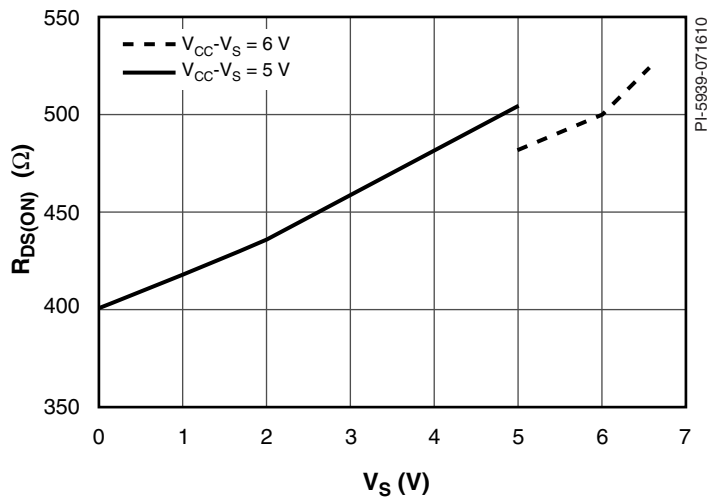

Figure 7. Typical $R_{DS(ON)}$ as a Function of V_S Voltage.

Applications Considerations

The maximum voltage that the device can sustain across the VOLTAGE SUPPLY and GROUND pin is 16 V. The maximum voltage that any of the source channels can be at with respect to the ground terminal is 6.5 V. SENZero has a typical on state resistance of approximately 500 Ω at room temperature. The device is therefore typically used in series with high ohmic value resistors where this on resistance is a small percentage of the total series impedance.

It is not necessary to provide a local bypass capacitor on the VOLTAGE SUPPLY pin.

Operating Configurations for the SENZero

One configuration to power up the SENZero is shown in Figure 8. In this circuit, SENZero is powered up from an unregulated bias winding through a simple series pass regulator formed by Q1, R_B and V_Z. This configuration ensures the VCC voltage is limited even if the maximum bias voltage exceeds 16 V. During power-down, as soon as the bias voltage falls below V_Z, SENZero will turn off.

The series pass transistor Q1 is necessary only if the bias winding voltage regulation is not tight enough (unregulated). If the voltage on the bias winding is regulated or is such that the voltage on the VOLTAGE SUPPLY pin can be maintained in the range 6 V < VCC < 16 V, then the series pass transistor (Q1, R_B and V_Z) can be eliminated.

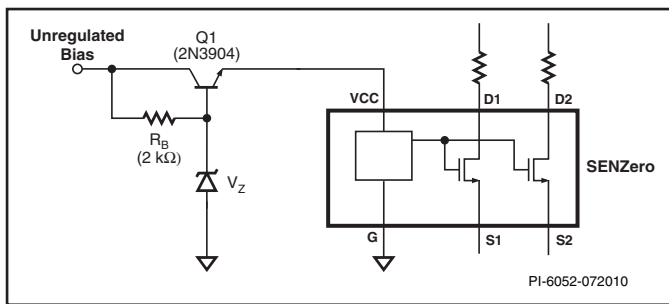

Figure 8. SENZero Powered from an Unregulated Bias Winding Through a Series Pass Regulator. Device is Enabled when Bias Voltage is Present.

A configuration that can be used to trigger remote-off functionality is shown in Figure 9. In this configuration, a regulated auxiliary output is used to power the IC. Transistor Q1 serves as the ON/OFF switch which is commanded by the Enable/Disable signal at its base.

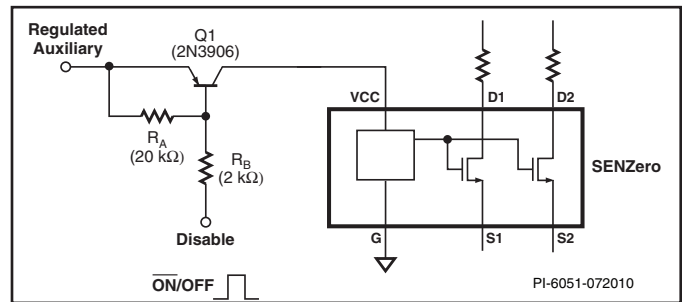

Figure 9. SENZero Powered from a Regulated Auxiliary Winding.

An alternative remote-off configuration is shown in Figure 10 where an unregulated bias voltage supplies the SENZero through a series pass regulator similar to the one shown in Figure 8. However the circuit of Figure 10 includes an ON/OFF transistor Q2. In other versions of this circuit Q2 can be replaced by an optocoupler allowing the ON/OFF disable signal to be communicated from a secondary of the power supply such as in PC power supplies.

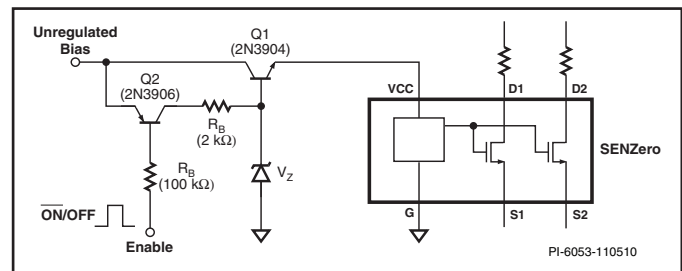

Figure 10. A Modified Version of an Unregulated Bias Winding Supplying Power Through a Series Pass Regulator. Transistor Q2 Provides Remote-Off Functionality.

Application Example

SENZero in PFC Bus Voltage Feedback Network

Commercial PFC IC's typically has a pin dedicated for sensing the output voltage of the PFC Stage. The information on this pin is typically used by the PFC IC for various major functions.

1. Output regulation – input to the non-inverting input of the error amplifier.
2. OVP detection – input to the OVP comparator.
3. Open-loop protection – used to detect open-loop conditions.

The last 2 functions were used for protecting the bus from overvoltage condition.

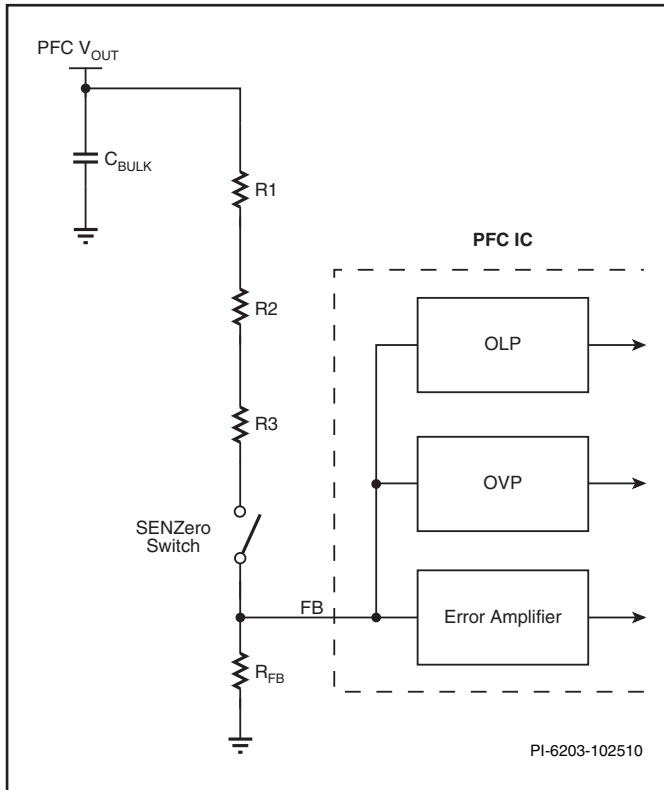

Figure 11. PFC Bus Voltage Sense Network.

The SENZero objective is to eliminate the losses associated with the sense resistors without affecting the functionality of the circuit. To keep the operation of the PFC IC unaffected, SENZero and PFC on and off event must follow the required timing sequence during power-up, power-down, remote-on, and remote-off event.

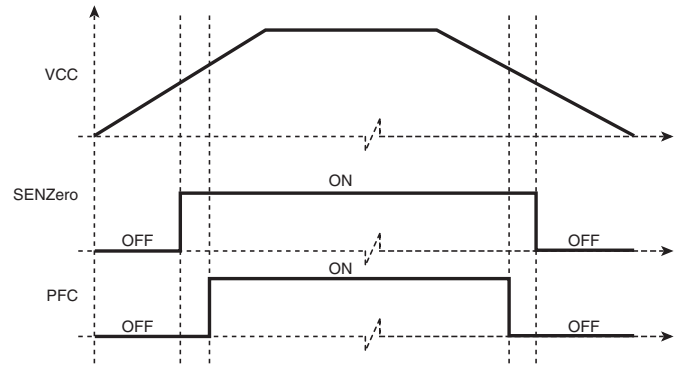

Figure 12. Timing between PFC IC and SENZero during Power-Up and Power-Down.

In case of shared VCC Connection, it must be ensure that SENZero have a lower turn-on and turn-off threshold voltage compared to the PFC IC.

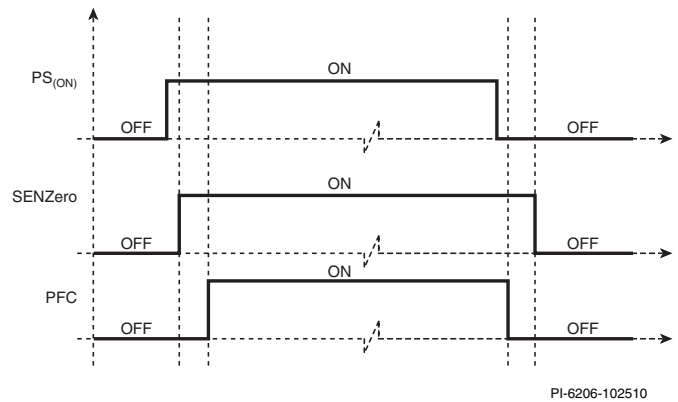

Figure 13. Timing between PFC IC and SENZero with $PS_{(ON)}$ Signal.

From off-state to on-state, SENZero must turn-on ahead of the PFC. From on-state to off-state, PFC must shutdown ahead of the SENZero. This is to ensure that whenever PFC is operating (switching), SENZero is invincible to the PFC. SENZero only disconnects the sense resistors when PFC is in off-condition and thus eliminates its associated losses during standby condition.

Absolute Maximum Ratings^(1,3)

DRAIN Pin Voltage (D1, D2, D3)	-0.3 V to 650 V
VOLTAGE SUPPLY Pin Voltage	-0.3 V to 16 V
Voltage on S1, S2, S3 Pins	-0.3 V to 6.5 V
Storage Temperature	-65 °C to 150 °C
Operating Junction Temperature	-40 °C to 125 °C
Lead Temperature ⁽²⁾	260 °C

Notes:

- All voltages referenced to Ground, $T_A = 25\text{ °C}$.
- 1/16 in. from case for 5 seconds.
- The Absolute Maximum Ratings specified may be applied one at a time without causing permanent damage to the product. Exposure to Absolute Maximum Rating conditions for extended periods of time may affect product reliability.

Thermal Resistance

Thermal Resistance: D Package⁽¹⁾:

(θ_{JA})	160 °C/W (Single layer JEDEC PCB)
(θ_{JC})	40 °C/W (Bottom)
(θ_{JC})	75 °C/W (Top)

Notes:

- Reference thermal resistance test conditions: JEDEC JESD51-3, SEMI Test Method #G43-87, and MIL-STD-883 Method 10121.1.

Parameter	Symbol	Conditions $T_A = -40\text{ °C to }105\text{ °C}$ (Unless Otherwise Specified)	Min	Typ	Max	Units	
Input							
VCC Pin Input Current	I_{VCC}	Measured at $V_{CC(MAX)}$			0.5	mA	
MOSFET ON-Drive Voltage ($V_{CC} - [\text{Max of } V_{S1}, V_{S2} \text{ and } V_{S3}]$)	$V_{CC(ON)}$	See Note A	$V_S < 5\text{ V}$	5		V	
			$V_S \geq 5\text{ V}$	6			
Output							
ON-State Resistance	$R_{DS(ON)}$	$V_S = 0\text{ V}$ $V_{CC(ON)} = 5\text{ V}$ $I_D = 1\text{ mA}$ See Note D	$T_J = 25\text{ °C}$		400	Ω	
			$T_J = 100\text{ °C}$		550		
		$V_S = 6.5\text{ V}$ $V_{CC(ON)} = 6\text{ V}$ $I_D = 1\text{ mA}$	$T_J = 25\text{ °C}$		525		650
			$T_J = 100\text{ °C}$		750		1000
OFF-State Drain Leakage	I_{DSS}	$V_{DS} = 325\text{ V}, T_J = 25\text{ °C}, V_{CC} = V_S = 0\text{ V}$ See Note B			1	μA	
Breakdown Voltage	BV_{DSS}	$T_J = 25\text{ °C}$ See Note C	650			V	
Q1, Q2 and Q3 Saturation Current	$I_{DS(ON)}$	$T_J = 100\text{ °C}, V_{CC(ON)} = 5\text{ V}$	1			mA	

NOTES:

- This is the minimum voltage difference required between V_{CC} and the highest of voltages V_{S1} , V_{S2} and V_{S3} to achieve the $R_{DS(ON)}$ specification in the parameter table. As an example, if S1 externally connects to a controller pin having a voltage of 4 V relative to GROUND pin, $V_{CC(ON)}$ of 5 V will be achieved by having at least $(5\text{ V} + 4\text{ V}) = 9\text{ V}$ applied to the SENZero VOLTAGE SUPPLY (VCC) pin relative to the GROUND pin.
- Per channel.
- Between Ground and Drain of individual MOSFET under test.
- Guaranteed by design.

SO-8 (D Package)

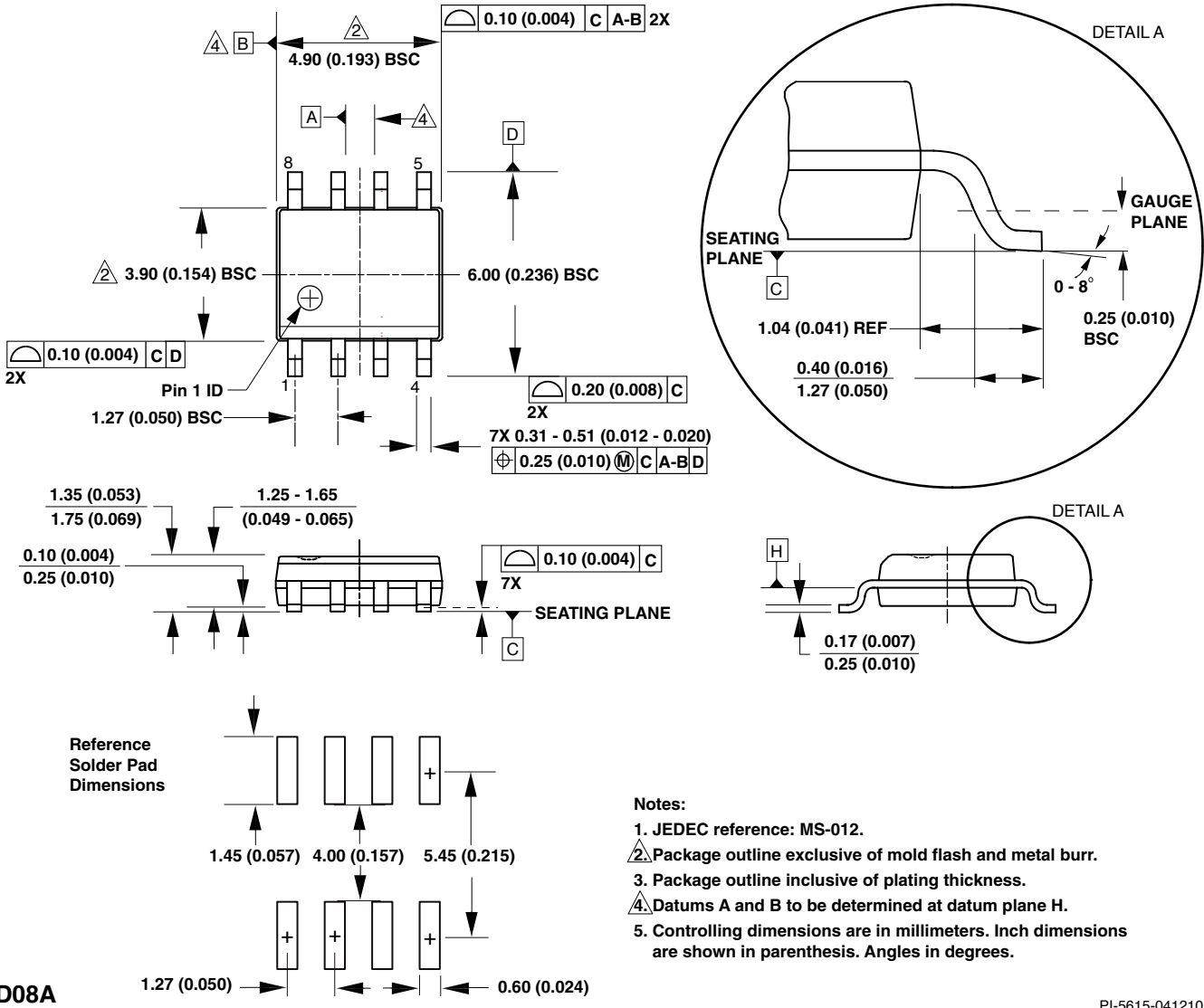

Part Ordering Information

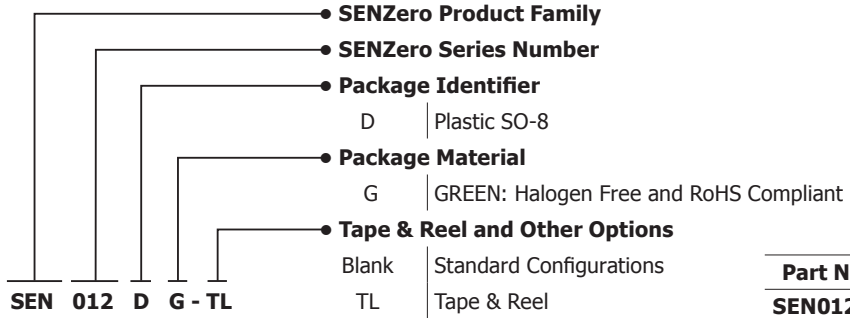

Part Number	Options	Quantity
SEN012DG	Tube	98
SEN012DG-TL	Tape and Reel	2500
SEN013DG	Tube	98
SEN013DG-TL	Tape and Reel	2500

Revision	Notes	Date
A	Initial Release.	08/18/10
B	Added Applications Example section, updated Figure 9.	11/05/10
B	Added Thermal Resistance section.	09/16/13
C	Updated with new Brand Style.	05/15/15

For the latest updates, visit our website: www.power.com

Power Integrations reserves the right to make changes to its products at any time to improve reliability or manufacturability. Power Integrations does not assume any liability arising from the use of any device or circuit described herein. POWER INTEGRATIONS MAKES NO WARRANTY HEREIN AND SPECIFICALLY DISCLAIMS ALL WARRANTIES INCLUDING, WITHOUT LIMITATION, THE IMPLIED WARRANTIES OF MERCHANTABILITY, FITNESS FOR A PARTICULAR PURPOSE, AND NON-INFRINGEMENT OF THIRD PARTY RIGHTS.

Patent Information

The products and applications illustrated herein (including transformer construction and circuits external to the products) may be covered by one or more U.S. and foreign patents, or potentially by pending U.S. and foreign patent applications assigned to Power Integrations. A complete list of Power Integrations patents may be found at www.power.com. Power Integrations grants its customers a license under certain patent rights as set forth at <http://www.power.com/ip.htm>.

Life Support Policy

POWER INTEGRATIONS PRODUCTS ARE NOT AUTHORIZED FOR USE AS CRITICAL COMPONENTS IN LIFE SUPPORT DEVICES OR SYSTEMS WITHOUT THE EXPRESS WRITTEN APPROVAL OF THE PRESIDENT OF POWER INTEGRATIONS. As used herein:

1. A Life support device or system is one which, (i) is intended for surgical implant into the body, or (ii) supports or sustains life, and (iii) whose failure to perform, when properly used in accordance with instructions for use, can be reasonably expected to result in significant injury or death to the user.
2. A critical component is any component of a life support device or system whose failure to perform can be reasonably expected to cause the failure of the life support device or system, or to affect its safety or effectiveness.

The PI logo, TOPSwitch, TinySwitch, LinkSwitch, LYTSwitch, InnoSwitch, DPA-Switch, PeakSwitch, CAPZero, SENZero, LinkZero, HiperPFS, HiperTFS, HiperLCS, Qspeed, EcoSmart, Clampless, E-Shield, Filterfuse, FluxLink, StakFET, PI Expert and PI FACTS are trademarks of Power Integrations, Inc. Other trademarks are property of their respective companies. ©2015, Power Integrations, Inc.

Power Integrations Worldwide Sales Support Locations

World Headquarters

5245 Hellyer Avenue
San Jose, CA 95138, USA.
Main: +1-408-414-9200
Customer Service:
Phone: +1-408-414-9665
Fax: +1-408-414-9765
e-mail: usasales@power.com

China (Shanghai)

Rm 2410, Charity Plaza, No. 88
North Caoxi Road
Shanghai, PRC 200030
Phone: +86-21-6354-6323
Fax: +86-21-6354-6325
e-mail: chinasales@power.com

China (Shenzhen)

17/F, Hivac Building, No. 2, Keji Nan
8th Road, Nanshan District,
Shenzhen, China, 518057
Phone: +86-755-8672-8689
Fax: +86-755-8672-8690
e-mail: chinasales@power.com

Germany

Lindwurmstrasse 114
80337 Munich
Germany
Phone: +49-895-527-39110
Fax: +49-895-527-39200
e-mail: eurosales@power.com

India

#1, 14th Main Road
Vasanthanagar
Bangalore-560052 India
Phone: +91-80-4113-8020
Fax: +91-80-4113-8023
e-mail: indiasales@power.com

Italy

Via Milanese 20, 3rd. Fl.
20099 Sesto San Giovanni (MI)
Italy
Phone: +39-024-550-8701
Fax: +39-028-928-6009
e-mail: eurosales@power.com

Japan

Kosei Dai-3 Bldg.
2-12-11, Shin-Yokohama,
Kohoku-ku
Yokohama-shi Kanagwan
222-0033 Japan
Phone: +81-45-471-1021
Fax: +81-45-471-3717
e-mail: japansales@power.com

Korea

RM 602, 6FL
Korea City Air Terminal B/D, 159-6
Samsung-Dong, Kangnam-Gu,
Seoul, 135-728, Korea
Phone: +82-2-2016-6610
Fax: +82-2-2016-6630
e-mail: koreasales@power.com

Singapore

51 Newton Road
#19-01/05 Goldhill Plaza
Singapore, 308900
Phone: +65-6358-2160
Fax: +65-6358-2015
e-mail: singaporesales@power.com

Taiwan

5F, No. 318, Nei Hu Rd., Sec. 1
Nei Hu Dist.
Taipei 11493, Taiwan R.O.C.
Phone: +886-2-2659-4570
Fax: +886-2-2659-4550
e-mail: taiwansales@power.com

UK

First Floor, Unit 15, Meadway Court,
Rutherford Close,
Stevenage, Herts. SG1 2EF
United Kingdom
Phone: +44 (0) 1252-730-141
Fax: +44 (0) 1252-727-689
e-mail: eurosales@power.com

Looking for pricing, stock, or lifecycle information?

Click below to explore more details on WIN SOURCE:

 [View SEN013DG on WIN SOURCE](#)

 [Power Integrations](#) Information

Optimize Your Supply Chain with WIN SOURCE Solutions

-  Global Sourcing Solution
-  Obsolete Management
-  Cost Control Management
-  Shortage Management
-  Alternative Solution
-  Excess Inventory Management