



**THE DATASHEET OF
MAX6501UKP125**



LMK62XX High-Performance Low Jitter Oscillator

1 Features

- Low noise, high performance
 - Jitter: 150 fs RMS typical Fout > 100 MHz
 - PSRR: –60 dBc, robust supply noise immunity
- Supported output format:
 - LVPECL, LVDS and HCSL up to 400 MHz
- Total frequency tolerance: ±50 ppm (LMK62X2) and ±25 ppm (LMK62X0)
- 3.3-V operating voltage
- Industrial temperature range: –40°C to +85°C
- 5-mm × 3.2-mm 6-pin package that is pin-compatible with industry standard 5032 XO package

2 Applications

- High-performance replacement for crystal-, SAW-, or silicon-based oscillators
- Switches, routers, network line cards, Base Band Units (BBU), servers, storage/SAN
- Test and measurement
- Medical imaging
- FPGA, processor attach

3 Description

The LMK62XX device is a low jitter oscillator that generates a commonly used reference clock. The device is pre-programmed in factory to support any reference clock frequency; supported output formats are LVPECL, LVDS and HCSL up to 400 MHz. Internal power conditioning provide excellent power supply ripple rejection (PSRR), reducing the cost and complexity of the power delivery network. The device operates from a single 3.3-V ±5% supply.

Device Information

PART NUMBER	OUTPUT FREQUENCY (MHz) AND FORMAT	TOTAL FREQUENCY STABILITY (ppm)	PACKAGE SIZE ^{(1) (2)}
LMK62E2-100M	100 LVPECL	±50	SIA (QFM, 6) 5.00 mm × 3.20 mm
LMK62E2-156M	156.25 LVPECL	±50	
LMK62E0-156M	156.25 LVPECL	±25	
LMK62A2-100M	100 LVDS	±50	
LMK62A2-150M	150 LVDS	±50	
LMK62A2-156M	156.25 LVDS	±50	
LMK62A2-200M	200 LVDS	±50	
LMK62A2-266M	266.66 LVDS	±50	
LMK62I0-100M	100 HCSL	±25	
LMK62I0-156M	156.25 HCSL	±25	

- (1) For all available packages, see [Section 10](#).
 (2) The package size (length × width) is a nominal value and includes pins, where applicable.

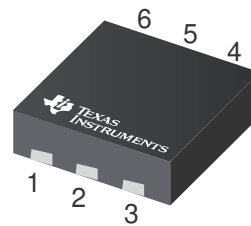
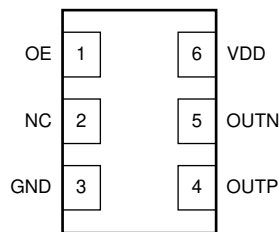

Pinout



Table of Contents

1 Features	1	5.13 PLL Clock Output Jitter Characteristics.....	6
2 Applications	1	5.14 Additional Reliability and Qualification.....	7
3 Description	1	6 Parameter Measurement Information	8
4 Pin Configuration and Functions	3	6.1 Device Output Configurations.....	8
5 Specifications	3	7 Application and Implementation	10
5.1 Absolute Maximum Ratings.....	3	7.1 Power Supply Recommendations.....	10
5.2 ESD Ratings.....	3	7.2 Layout.....	10
5.3 Recommended Operating Conditions.....	4	8 Device and Documentation Support	12
5.4 Thermal Information.....	4	8.1 Receiving Notification of Documentation Updates....	12
5.5 Electrical Characteristics - Power Supply.....	4	8.2 Support Resources.....	12
5.6 LVPECL Output Characteristics.....	4	8.3 Trademarks.....	12
5.7 LVDS Output Characteristics.....	5	8.4 Electrostatic Discharge Caution.....	12
5.8 HCSL Output Characteristics.....	5	8.5 Glossary.....	12
5.9 OE Input Characteristics.....	5	9 Revision History	12
5.10 Frequency Tolerance Characteristics.....	6	10 Mechanical, Packaging, and Orderable Information	12
5.11 Power-On/Reset Characteristics (VDD).....	6		
5.12 PSRR Characteristics.....	6		

4 Pin Configuration and Functions

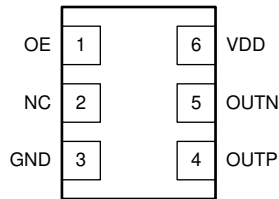

Figure 4-1. SIA Package 6-pin QFM Top View

Table 4-1. Pin Functions

PIN		I/O	DESCRIPTION
NAME	NO.		
POWER			
GND	3	Ground	Device ground
VDD	6	Analog	3.3-V power supply
OUTPUT BLOCK			
OUTP	4	Universal	Differential output pair (LVPECL, LVDS or HCSL).
OUTN	5		
DIGITAL CONTROL / INTERFACES			
NC	2	N/A	No connect
OE	1	LVC MOS	Output enable (internal pulldown). When set to low, output pair is disabled and set at high impedance. The recommended external pullup resistor value is 10 kΩ.

5 Specifications

5.1 Absolute Maximum Ratings

over operating free-air temperature range (unless otherwise noted)⁽¹⁾

		MIN	MAX	UNIT
VDD	Device supply voltage	-0.3	3.6	V
V _{IN}	Output voltage for logic inputs	-0.3	VDD + 0.3	V
V _{OUT}	Output voltage for clock outputs	-0.3	VDD + 0.3	V
T _J	Junction temperature		150	°C
T _{stg}	Storage temperature	-40	125	°C

- (1) Stresses beyond those listed under *Absolute Maximum Ratings* may cause permanent damage to the device. These are stress ratings only, which do not imply functional operation of the device at these or any other conditions beyond those indicated under *Recommended Operating Conditions*. Exposure to absolute maximum-rated conditions for extended periods may affect device reliability.

5.2 ESD Ratings

		VALUE	UNIT
V _(ESD)	Electrostatic discharge	Human-body model (HBM), per ANSI/ESDA/JEDEC JS-001 ⁽¹⁾	±2000
		Charged-device model (CDM), per JEDEC specification JESD22-C101 ⁽²⁾	±500

- (1) JEDEC document JEP155 states that 500-V HBM allows safe manufacturing with a standard ESD control process.
 (2) JEDEC document JEP157 states that 250-V CDM allows safe manufacturing with a standard ESD control process.

5.3 Recommended Operating Conditions

over operating free-air temperature range (unless otherwise noted)

		MIN	NOM	MAX	UNIT
VDD	Device supply voltage	3.135	3.3	3.465	V
T _A	Ambient temperature	-40	25	85	°C
T _J	Junction temperature			105	°C
t _{RAMP}	VDD power-up ramp time	0.1		100	ms

5.4 Thermal Information

THERMAL METRIC ⁽¹⁾		LMK62XX ⁽²⁾ ⁽³⁾ ⁽⁴⁾		UNIT
		SIA (QFM)		
		6 PINS		
		Airflow (LFM) 0		
R _{θJA}	Junction-to-ambient thermal resistance	94.5		°C/W
R _{θJC(top)}	Junction-to-case (top) thermal resistance	65.1		°C/W
R _{θJB}	Junction-to-board thermal resistance	59		°C/W
ψ _{JT}	Junction-to-top characterization parameter	23.3		°C/W
ψ _{JB}	Junction-to-board characterization parameter	64.1		°C/W
R _{θJC(bot)}	Junction-to-case (bottom) thermal resistance	n/a		°C/W

- (1) For more information about traditional and new thermal metrics, see the [Semiconductor and IC Package Thermal Metrics](#) application report.
- (2) The package thermal resistance is calculated on a 4-layer JEDEC board.
- (3) Connected to GND with 2 thermal vias (0.3-mm diameter).
- (4) ψ_{JB} (junction to board) is used when the main heat flow is from the junction to the GND pad. Please refer to Thermal Considerations section for more information on ensuring good system reliability and quality.

5.5 Electrical Characteristics - Power Supply

VDD = 3.3 V ± 5%, T_A = -40°C to 85°C⁽¹⁾

PARAMETER	TEST CONDITIONS	MIN	TYP	MAX	UNIT
IDD	Device current consumption	LVPECL ⁽²⁾	95	110	mA
		LVDS	85	100	
		HCSL ⁽³⁾	90	105	
IDD-PD	Device current consumption when output is disabled	OE = GND	70		mA

- (1) See [Parameter Measurement Information](#) for relevant test conditions.
- (2) On-chip power dissipation should exclude 40 mW, dissipated in the 150-Ω termination resistors, from total power dissipation.
- (3) Excludes load current.

5.6 LVPECL Output Characteristics

VDD = 3.3 V ± 5%, T_A = -40°C to 85°C⁽¹⁾

PARAMETER	TEST CONDITIONS	MIN	TYP	MAX	UNIT
f _{OUT}	Output frequency ⁽²⁾			400	MHz
V _{OD}	Output voltage swing (V _{OH} - V _{OL}) ⁽²⁾	700	950	1200	mV
V _{OUT, DIFF, PP}	Differential output peak-to-peak swing		2 × V _{OD}		V
V _{OS}	Output common-mode voltage		VDD - 1.45		V
t _R / t _F	Output rise/fall time (20% to 80%) ⁽³⁾		260	350	ps
ODC	Output duty cycle ⁽³⁾	45%		55%	

- (1) See [Parameter Measurement Information](#) for relevant test conditions.
- (2) An output frequency over f_{OUT} max spec is possible, but output swing may be less than V_{OD} min spec.

(3) Ensured by characterization.

5.7 LVDS Output Characteristics

VDD = 3.3 V ± 5%, T_A = –40°C to 85°C⁽¹⁾

PARAMETER	TEST CONDITIONS	MIN	TYP	MAX	UNIT
f _{OUT}	Output frequency ⁽¹⁾			400	MHz
V _{OD}	Output voltage swing (V _{OH} - V _{OL}) ⁽¹⁾	300	390	480	mV
V _{OUT, DIFF, PP}	Differential output peak-to-peak swing		2 x V _{OD}		V
V _{OS}	Output common-mode voltage	1.125	1.2	1.375	V
t _R / t _F	Output rise/fall time (20% to 80%) ⁽²⁾		260	350	ps
ODC	Output duty cycle ⁽²⁾	45%		55%	
R _{OUT}	Differential output impedance		107		Ω

(1) An output frequency over f_{OUT} max spec is possible, but output swing may be less than V_{OD} min spec.

(2) Ensured by characterization.

5.8 HCSL Output Characteristics

VDD = 3.3 V ± 5%, T_A = –40°C to 85°C⁽¹⁾

PARAMETER	TEST CONDITIONS	MIN	TYP	MAX	UNIT
f _{OUT}	Output frequency			400	MHz
V _{OH}	Output high voltage	660		900	mV
V _{OL}	Output low voltage	–100		100	mV
V _{CROSS}	Absolute crossing voltage ^{(2) (3)}	250		475	mV
V _{CROSS-DELTA}	Variation of V _{CROSS} ^{(2) (3)}	0		140	mV
dV/dt	Slew rate ⁽⁴⁾	1		3	V/ns
ODC	Output duty cycle ⁽⁴⁾	45%		55%	

(1) See [Parameter Measurement Information](#) for relevant test conditions.

(2) Measured from -150 mV to +150 mV on the differential waveform with the 300 mVpp measurement window centered on the differential zero crossing.

(3) Ensured by design.

(4) Ensured by characterization.

5.9 OE Input Characteristics

VDD = 3.3 V ± 5%, T_A = –40°C to 85°C

PARAMETER	TEST CONDITIONS	MIN	TYP	MAX	UNIT
V _{IH}	Input high voltage	1.4			V
V _{IL}	Input low voltage			0.6	V
I _{IH}	Input high current	V _{IH} = VDD		40	μA
I _{IL}	Input low current	V _{IL} = GND		40	μA
C _{IN}	Input capacitance		2		pF

5.10 Frequency Tolerance Characteristics

VDD = 3.3 V ± 5%, T_A = –40°C to 85°C⁽¹⁾

PARAMETER	TEST CONDITIONS	MIN	TYP	MAX	UNIT
f _T Total frequency tolerance	LMK62X2: All output formats, frequency bands and device junction temperature up to 105°C; includes initial freq tolerance, temperature & supply voltage variation, solder reflow and 5-year aging at 40°C	–50		50	ppm
	LMK62X0: All output formats, frequency bands and device junction temperature up to 105°C; includes initial freq tolerance, temperature & supply voltage variation, solder reflow and 5-year aging at 40°C	–25		25	ppm

(1) Ensured by characterization.

5.11 Power-On/Reset Characteristics (VDD)

VDD = 3.3 V ± 5%, T_A = –40°C to 85°C

PARAMETER	TEST CONDITIONS	MIN	TYP	MAX	UNIT
V _{THRESH} Threshold voltage ⁽¹⁾		2.85		3	V
V _{DRPOOP} Allowable voltage droop ⁽²⁾				0.1	V
t _{STARTUP} Start-up time ⁽¹⁾	Time elapsed from VDD at 3.135 V to output enabled			10	ms
t _{OE-EN} Output enable time ⁽²⁾	Time elapsed from OE at V _{IH} to output enabled			50	μs
t _{OE-DIS} Output disable time ⁽²⁾	Time elapsed from OE at V _{IL} to output disabled			50	μs

(1) Ensured by characterization.

(2) Ensured by design.

5.12 PSRR Characteristics

VDD = 3.3 V, T_A = 25°C⁽¹⁾

PARAMETER	TEST CONDITIONS	MIN	TYP	MAX	UNIT
PSRR Spurs induced by 50-mV power supply ripple ⁽²⁾ at 156.25-MHz output, all output types	Sine wave at 50 kHz		–60		dBc
	Sine wave at 100 kHz		–60		
	Sine wave at 500 kHz		–60		
	Sine wave at 1 MHz		–60		

(1) See [Parameter Measurement Information](#) for relevant test conditions.

(2) Measured max spur level with 50 mVpp sinusoidal signal between 50 kHz and 1 MHz applied on VDD pin

(3) DJ_{SPUR} (ps, pk-pk) = $[2 \cdot 10 \cdot (SPUR/20) / (\pi \cdot f_{OUT})] \cdot 1e6$, where PSRR or SPUR in dBc and f_{OUT} in MHz.

5.13 PLL Clock Output Jitter Characteristics

VDD = 3.3 V ± 5%, T_A = –40°C to 85°C⁽¹⁾ (3)

PARAMETER	TEST CONDITIONS	MIN	TYP	MAX	UNIT
RJ RMS phase jitter ⁽²⁾ (12 kHz – 20 MHz)	f _{OUT} ≥ 100 MHz, all output types		150	250	fs RMS

(1) See [Parameter Measurement Information](#) for relevant test conditions.

(2) Ensured by characterization.

(3) Phase jitter measured with Agilent E5052 signal source analyzer using a differential-to-single ended converter (balun or buffer).



5.14 Additional Reliability and Qualification

PARAMETER	CONDITION / TEST METHOD
Mechanical Shock	MIL-STD-202, Method 213
Mechanical Vibration	MIL-STD-202, Method 204
Moisture Sensitivity Level	J-STD-020, MSL3

6 Parameter Measurement Information

6.1 Device Output Configurations

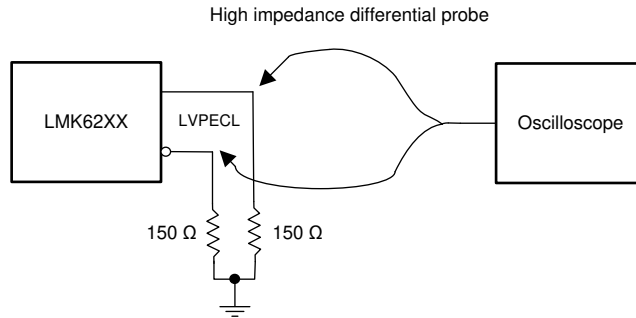

Copyright © 2017, Texas Instruments Incorporated

Figure 6-1. LVPECL Output DC Configuration During Device Test

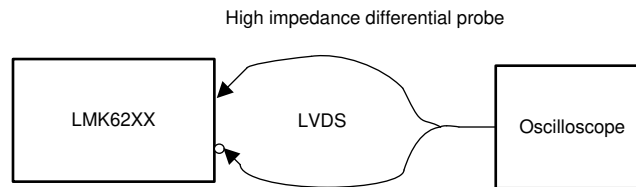

Copyright © 2017, Texas Instruments Incorporated

Figure 6-2. LVDS Output DC Configuration During Device Test

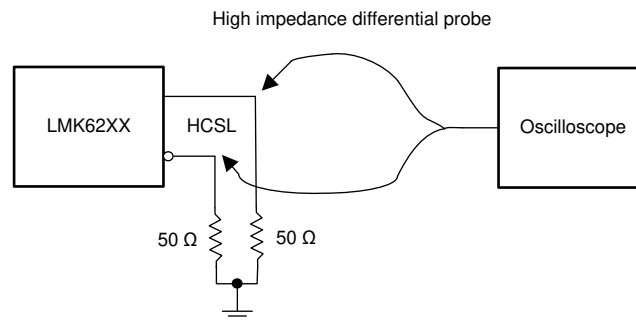

Copyright © 2017, Texas Instruments Incorporated

Figure 6-3. HCSL Output DC Configuration During Device Test ¹

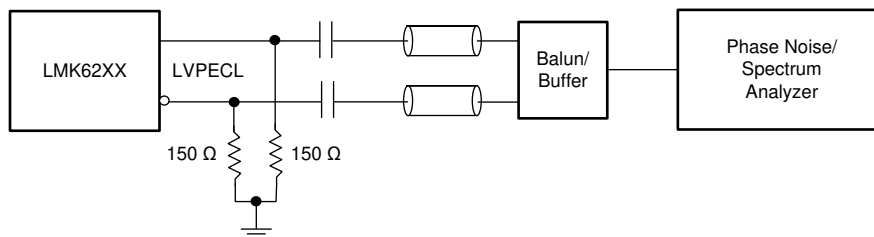

Copyright © 2017, Texas Instruments Incorporated

Figure 6-4. LVPECL Output AC Configuration During Device Test

¹ Also compatible with 85 Ω termination

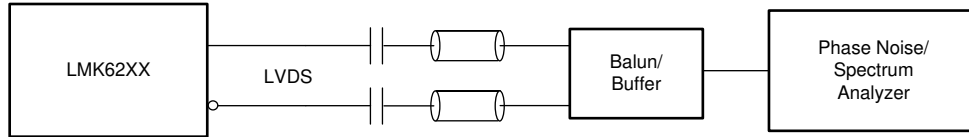

Copyright © 2017, Texas Instruments Incorporated

Figure 6-5. LVDS Output AC Configuration During Device Test

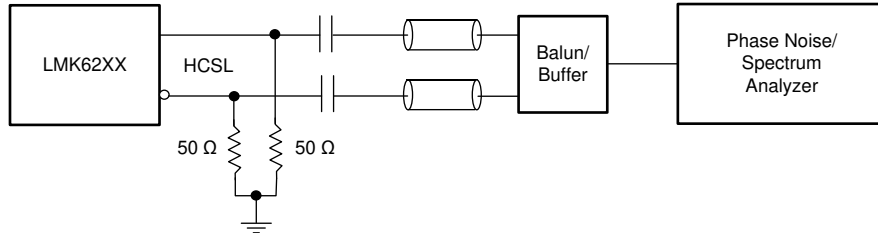

Copyright © 2017, Texas Instruments Incorporated

Figure 6-6. HCSL Output AC Configuration During Device Test

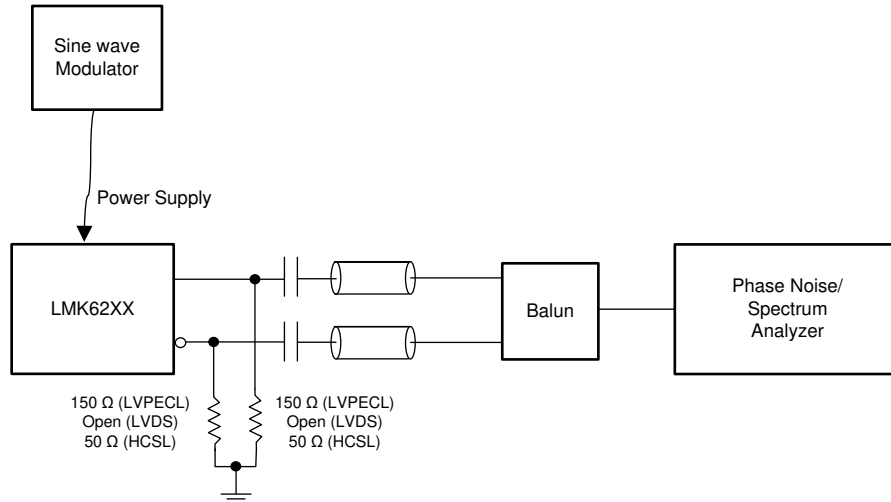

Copyright © 2017, Texas Instruments Incorporated

Figure 6-7. PSRR Test Setup

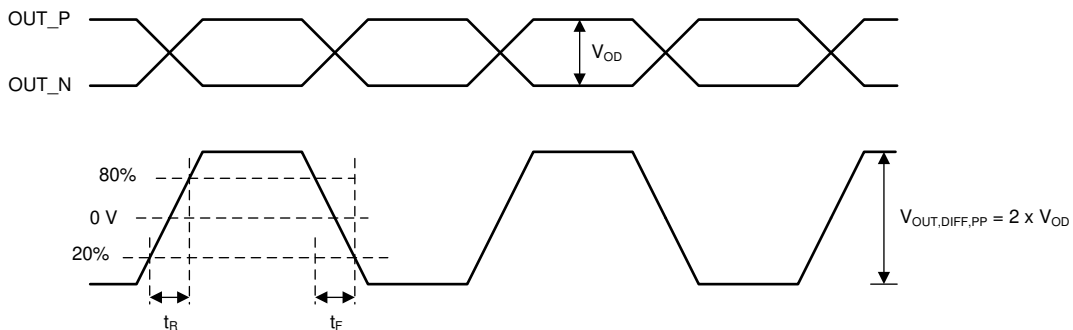

Figure 6-8. Differential Output Voltage and Rise/Fall Time

7 Application and Implementation

Note

Information in the following applications sections is not part of the TI component specification, and TI does not warrant its accuracy or completeness. TI's customers are responsible for determining suitability of components for their purposes, as well as validating and testing their design implementation to confirm system functionality.

7.1 Power Supply Recommendations

For best electrical performance of LMK62XX, TI recommends using a combination of 10 μ F, 1 μ F, and 0.1 μ F on the power-supply bypass network of the device. TI also recommends using component side mounting of the power-supply bypass capacitors and it is best to use 0201 or 0402 body size capacitors to facilitate signal routing. Keep the connections between the bypass capacitors and the power supply on the device as short as possible. Ground the other side of the capacitor using a low impedance connection to the ground plane. [Figure 7-1](#) shows the layout recommendation for power supply decoupling of LMK62XX.

7.2 Layout

7.2.1 Layout Guidelines

The following sections provides recommendations for board layout, solder reflow profile and power supply bypassing when using LMK62XX to ensure good thermal / electrical performance and overall signal integrity of entire system.

7.2.1.1 Ensuring Thermal Reliability

The LMK62XX is a high-performance device. Therefore, pay careful attention to the device configuration and printed-circuit board (PCB) layout with respect to power consumption. The ground pin must be connected to the ground plane of the PCB through three vias or more, as shown in [Figure 7-1](#), to maximize thermal dissipation out of the package.

[Equation 1](#) shows the relationship between the PCB temperature around the LMK62XX and the junction temperature.

$$T_B = T_J - \Psi_{JB} \times P \quad (1)$$

where

- T_B : PCB temperature around the LMK62XX
- T_J : Junction temperature of LMK62XX
- Ψ_{JB} : Junction-to-board thermal resistance parameter of LMK62XX (64.1°C/W without airflow)
- P : On-chip power dissipation of LMK62XX

To ensure that the maximum junction temperature of LMK62XX is below 105°C, it can be calculated that the maximum PCB temperature without airflow should be at 81°C or below when the device is optimized for best performance, resulting in maximum on-chip power dissipation of 0.36 W.

7.2.1.2 Best Practices for Signal Integrity

For best electrical performance and signal integrity of entire system with LMK62XX, TI recommends routing vias into decoupling capacitors and then into the LMK62XX. TI also recommends increasing the via count and width of the traces wherever possible. These steps ensure lowest impedance and shortest path for high frequency current flow. [Figure 7-1](#) shows the layout recommendation for LMK62XX.

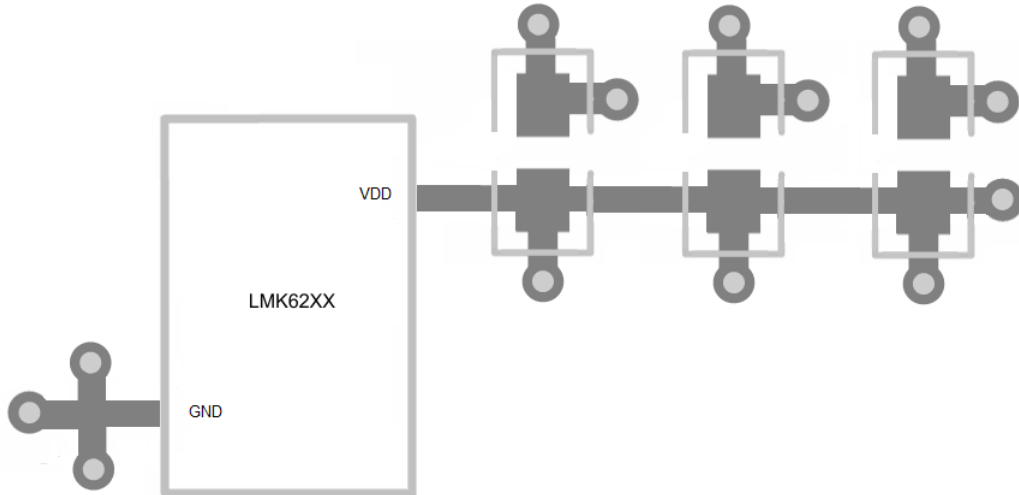

Figure 7-1. LMK62XX Layout Recommendation for Power Supply and Ground

7.2.1.3 Recommended Solder Reflow Profile

TI recommends following the recommendations set by the solder paste supplier to optimize flux activity and to achieve proper melting temperatures of the alloy within the guidelines of J-STD-20. Processing LMK62XX with the lowest peak temperature possible while also remaining below the components peak temperature rating as listed on the MSL label is preferred. The exact temperature profile would depend on several factors including maximum peak temperature for the component as rated on the MSL label, board thickness, PCB material type, PCB geometries, component locations, sizes, densities within PCB, as well as the recommended soldering profile from the manufacturer, and capability of the reflow equipment to as confirmed by the SMT assembly operation.

8 Device and Documentation Support

8.1 Receiving Notification of Documentation Updates

To receive notification of documentation updates, navigate to the device product folder on ti.com. Click on *Notifications* to register and receive a weekly digest of any product information that has changed. For change details, review the revision history included in any revised document.

8.2 Support Resources

TI E2E™ [support forums](#) are an engineer's go-to source for fast, verified answers and design help — straight from the experts. Search existing answers or ask your own question to get the quick design help you need.

Linked content is provided "AS IS" by the respective contributors. They do not constitute TI specifications and do not necessarily reflect TI's views; see TI's [Terms of Use](#).

8.3 Trademarks

TI E2E™ is a trademark of Texas Instruments.
 All trademarks are the property of their respective owners.

8.4 Electrostatic Discharge Caution



This integrated circuit can be damaged by ESD. Texas Instruments recommends that all integrated circuits be handled with appropriate precautions. Failure to observe proper handling and installation procedures can cause damage.

ESD damage can range from subtle performance degradation to complete device failure. Precision integrated circuits may be more susceptible to damage because very small parametric changes could cause the device not to meet its published specifications.

8.5 Glossary

[TI Glossary](#) This glossary lists and explains terms, acronyms, and definitions.

9 Revision History

NOTE: Page numbers for previous revisions may differ from page numbers in the current version.

Changes from Revision D (July 2018) to Revision E (December 2023)	Page
• Updated the numbering format for tables, figures, and cross-references throughout the document.....	1
• Changed the <i>Device Information</i> table.....	1
• Changed the OE pin description in the <i>Pin Functions</i> table.....	3
Changes from Revision C (December 2017) to Revision D (July 2018)	Page
• Added V_{OS} minimum and maximum values to the <i>LVDS Output Characteristics</i> table.....	5
Changes from Revision B (June 2017) to Revision C (December 2017)	Page
• Added the LMK62E2-100M, LMK62I0-100M, and LMK62I0-156M to device list	1
Changes from Revision A (April 2017) to Revision B (June 2017)	Page
• Added the LMK62E0-156M, LMK62A2-100M, LMK62A2-150M, LMK62A2-156M, LMK62A2-200M, and LMK62A2-266M to device list.....	1
Changes from Revision * (December 2016) to Revision A (April 2017)	Page
• Updated advanced information data sheet to production data	1

10 Mechanical, Packaging, and Orderable Information

The following pages include mechanical, packaging, and orderable information. This information is the most current data available for the designated devices. This data is subject to change without notice and revision of this document. For browser-based versions of this data sheet, refer to the left-hand navigation.

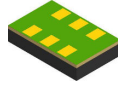

PACKAGE OUTLINE

SIA0006B

QFM - 1.1 mm max height

QUAD FLAT MODULE

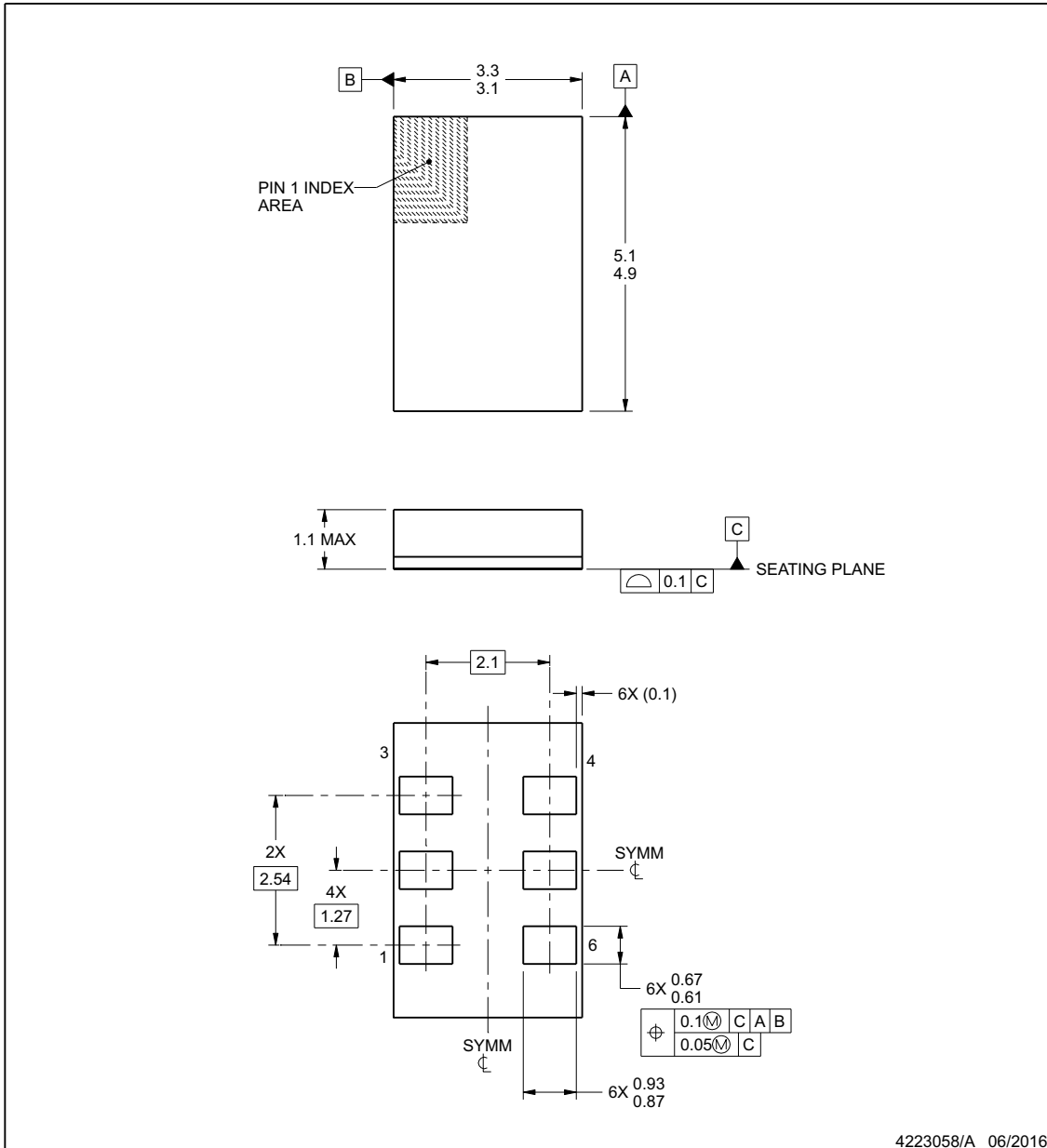

NOTES:

1. All linear dimensions are in millimeters. Any dimensions in parenthesis are for reference only. Dimensioning and tolerancing per ASME Y14.5M.
2. This drawing is subject to change without notice.

EXAMPLE BOARD LAYOUT

SIA0006B

QFM - 1.1 mm max height

QUAD FLAT MODULE

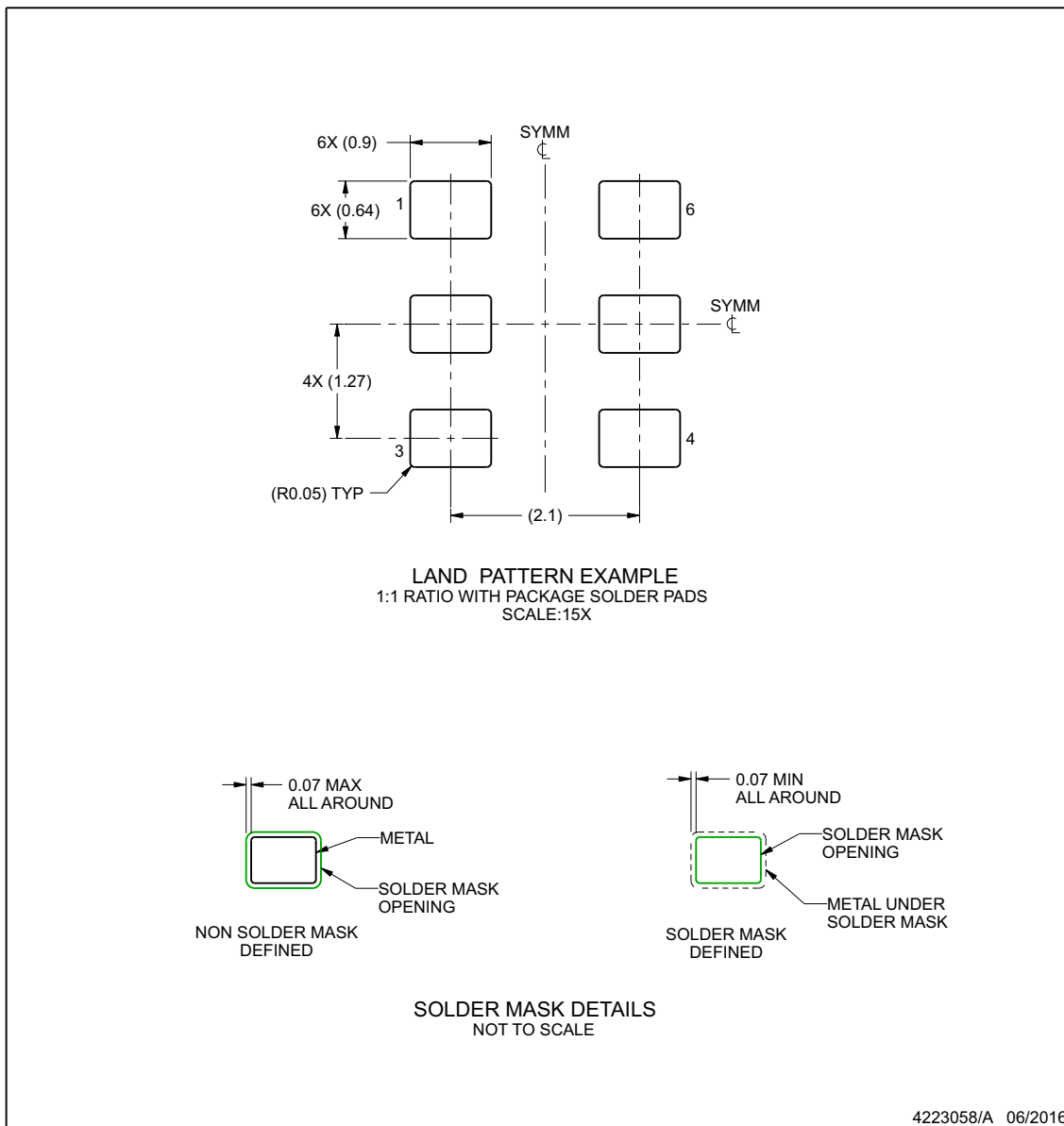

4223058/A 06/2016

NOTES: (continued)

3. For more information, see Texas Instruments literature number SLUA271 (www.ti.com/lit/slua271).

www.ti.com

EXAMPLE STENCIL DESIGN

SIA0006B

QFM - 1.1 mm max height

QUAD FLAT MODULE

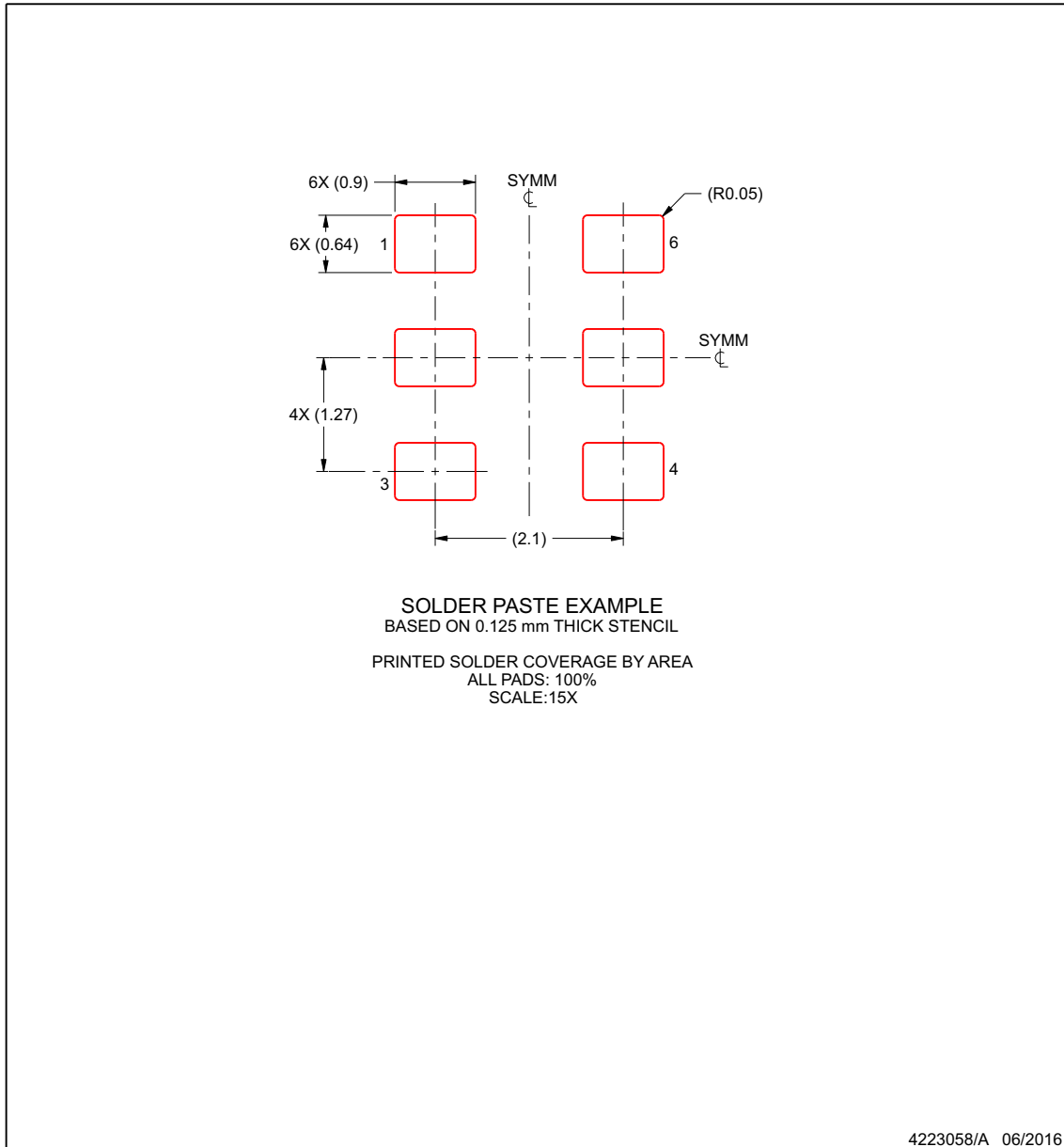

NOTES: (continued)

4. Laser cutting apertures with trapezoidal walls and rounded corners may offer better paste release. IPC-7525 may have alternate design recommendations.

www.ti.com

PACKAGING INFORMATION

Orderable Device	Status (1)	Package Type	Package Drawing	Pins	Package Qty	Eco Plan (2)	Lead finish/ Ball material (6)	MSL Peak Temp (3)	Op Temp (°C)	Device Marking (4/5)	Samples
LMK62A2-100M00SIAR	ACTIVE	QFM	SIA	6	2500	RoHS & Green	NIAU	Level-3-260C-168 HR	-40 to 85	62A2 10000	Samples
LMK62A2-100M00SIAT	ACTIVE	QFM	SIA	6	250	RoHS & Green	NIAU	Level-3-260C-168 HR	-40 to 85	62A2 10000	Samples
LMK62A2-150M00SIAR	ACTIVE	QFM	SIA	6	2500	RoHS & Green	NIAU	Level-3-260C-168 HR	-40 to 85	62A2 15000	Samples
LMK62A2-150M00SIAT	ACTIVE	QFM	SIA	6	250	RoHS & Green	NIAU	Level-3-260C-168 HR	-40 to 85	62A2 15000	Samples
LMK62A2-156M25SIAR	ACTIVE	QFM	SIA	6	2500	RoHS (In Work) & Green (In Work)	NIAU	Level-3-260C-168 HR	-40 to 85	62A2 15625	Samples
LMK62A2-156M25SIAT	ACTIVE	QFM	SIA	6	250	RoHS (In Work) & Green (In Work)	NIAU	Level-3-260C-168 HR	-40 to 85	62A2 15625	Samples
LMK62A2-200M00SIAR	ACTIVE	QFM	SIA	6	2500	RoHS & Green	NIAU	Level-3-260C-168 HR	-40 to 85	62A2 20000	Samples
LMK62A2-200M00SIAT	ACTIVE	QFM	SIA	6	250	RoHS & Green	NIAU	Level-3-260C-168 HR	-40 to 85	62A2 20000	Samples
LMK62A2-266M66SIAR	ACTIVE	QFM	SIA	6	2500	RoHS & Green	NIAU	Level-3-260C-168 HR	-40 to 85	62A2 26666	Samples
LMK62A2-266M66SIAT	ACTIVE	QFM	SIA	6	250	RoHS & Green	NIAU	Level-3-260C-168 HR	-40 to 85	62A2 26666	Samples
LMK62E0-156M25SIAR	ACTIVE	QFM	SIA	6	2500	RoHS (In Work) & Green (In Work)	NIAU	Level-3-260C-168 HR	-40 to 85	62E0 15625	Samples
LMK62E0-156M25SIAT	ACTIVE	QFM	SIA	6	250	RoHS & Green	NIAU	Level-3-260C-168 HR	-40 to 85	62E0 15625	Samples
LMK62E2-100M00SIAR	ACTIVE	QFM	SIA	6	2500	RoHS & Green	NIAU	Level-3-260C-168 HR	-40 to 85	62E2 10000	Samples
LMK62E2-100M00SIAT	ACTIVE	QFM	SIA	6	250	RoHS & Green	NIAU	Level-3-260C-168 HR	-40 to 85	62E2 10000	Samples
LMK62E2-156M25SIAR	ACTIVE	QFM	SIA	6	2500	RoHS & Green	NIAU	Level-3-260C-168 HR	-40 to 85	62E2 15625	Samples

Orderable Device	Status (1)	Package Type	Package Drawing	Pins	Package Qty	Eco Plan (2)	Lead finish/ Ball material (6)	MSL Peak Temp (3)	Op Temp (°C)	Device Marking (4/5)	Samples
LMK62E2-156M25SIAT	ACTIVE	QFM	SIA	6	250	RoHS & Green	NIAU	Level-3-260C-168 HR	-40 to 85	62E2 15625	Samples
LMK62I0-100M00SIAR	ACTIVE	QFM	SIA	6	2500	RoHS & Green	NIAU	Level-3-260C-168 HR	-40 to 85	62I0 10000	Samples
LMK62I0-100M00SIAT	ACTIVE	QFM	SIA	6	250	RoHS & Green	NIAU	Level-3-260C-168 HR	-40 to 85	62I0 10000	Samples
LMK62I0-156M25SIAR	ACTIVE	QFM	SIA	6	2500	RoHS & Green	NIAU	Level-3-260C-168 HR	-40 to 85	62I0 15625	Samples
LMK62I0-156M25SIAT	ACTIVE	QFM	SIA	6	250	RoHS & Green	NIAU	Level-3-260C-168 HR	-40 to 85	62I0 15625	Samples

(1) The marketing status values are defined as follows:

ACTIVE: Product device recommended for new designs.

LIFEBUY: TI has announced that the device will be discontinued, and a lifetime-buy period is in effect.

NRND: Not recommended for new designs. Device is in production to support existing customers, but TI does not recommend using this part in a new design.

PREVIEW: Device has been announced but is not in production. Samples may or may not be available.

OBSOLETE: TI has discontinued the production of the device.

(2) **RoHS:** TI defines "RoHS" to mean semiconductor products that are compliant with the current EU RoHS requirements for all 10 RoHS substances, including the requirement that RoHS substance do not exceed 0.1% by weight in homogeneous materials. Where designed to be soldered at high temperatures, "RoHS" products are suitable for use in specified lead-free processes. TI may reference these types of products as "Pb-Free".

RoHS Exempt: TI defines "RoHS Exempt" to mean products that contain lead but are compliant with EU RoHS pursuant to a specific EU RoHS exemption.

Green: TI defines "Green" to mean the content of Chlorine (Cl) and Bromine (Br) based flame retardants meet JS709B low halogen requirements of <=1000ppm threshold. Antimony trioxide based flame retardants must also meet the <=1000ppm threshold requirement.

(3) MSL, Peak Temp. - The Moisture Sensitivity Level rating according to the JEDEC industry standard classifications, and peak solder temperature.

(4) There may be additional marking, which relates to the logo, the lot trace code information, or the environmental category on the device.

(5) Multiple Device Markings will be inside parentheses. Only one Device Marking contained in parentheses and separated by a "~" will appear on a device. If a line is indented then it is a continuation of the previous line and the two combined represent the entire Device Marking for that device.

(6) Lead finish/Ball material - Orderable Devices may have multiple material finish options. Finish options are separated by a vertical ruled line. Lead finish/Ball material values may wrap to two lines if the finish value exceeds the maximum column width.

Important Information and Disclaimer: The information provided on this page represents TI's knowledge and belief as of the date that it is provided. TI bases its knowledge and belief on information provided by third parties, and makes no representation or warranty as to the accuracy of such information. Efforts are underway to better integrate information from third parties. TI has taken and continues to take reasonable steps to provide representative and accurate information but may not have conducted destructive testing or chemical analysis on incoming materials and chemicals. TI and TI suppliers consider certain information to be proprietary, and thus CAS numbers and other limited information may not be available for release.

In no event shall TI's liability arising out of such information exceed the total purchase price of the TI part(s) at issue in this document sold by TI to Customer on an annual basis.

TAPE AND REEL INFORMATION

QUADRANT ASSIGNMENTS FOR PIN 1 ORIENTATION IN TAPE

*All dimensions are nominal

Device	Package Type	Package Drawing	Pins	SPQ	Reel Diameter (mm)	Reel Width W1 (mm)	A0 (mm)	B0 (mm)	K0 (mm)	P1 (mm)	W (mm)	Pin1 Quadrant
LMK62A2-100M00SIAR	QFM	SIA	6	2500	330.0	12.4	3.5	5.3	1.3	8.0	12.0	Q1
LMK62A2-100M00SIAT	QFM	SIA	6	250	180.0	12.4	3.5	5.3	1.3	8.0	12.0	Q1
LMK62A2-150M00SIAR	QFM	SIA	6	2500	330.0	12.4	3.5	5.3	1.3	8.0	12.0	Q1
LMK62A2-150M00SIAT	QFM	SIA	6	250	180.0	12.4	3.5	5.3	1.3	8.0	12.0	Q1
LMK62A2-156M25SIAR	QFM	SIA	6	2500	330.0	12.4	3.5	5.3	1.3	8.0	12.0	Q1
LMK62A2-156M25SIAT	QFM	SIA	6	250	180.0	12.4	3.5	5.3	1.3	8.0	12.0	Q1
LMK62A2-200M00SIAR	QFM	SIA	6	2500	330.0	12.4	3.5	5.3	1.3	8.0	12.0	Q1
LMK62A2-200M00SIAT	QFM	SIA	6	250	180.0	12.4	3.5	5.3	1.3	8.0	12.0	Q1
LMK62A2-266M66SIAR	QFM	SIA	6	2500	330.0	12.4	3.5	5.3	1.3	8.0	12.0	Q1
LMK62A2-266M66SIAT	QFM	SIA	6	250	180.0	12.4	3.5	5.3	1.3	8.0	12.0	Q1
LMK62E0-156M25SIAR	QFM	SIA	6	2500	330.0	12.4	3.5	5.3	1.3	8.0	12.0	Q1
LMK62E0-156M25SIAT	QFM	SIA	6	250	180.0	12.4	3.5	5.3	1.3	8.0	12.0	Q1
LMK62E2-100M00SIAR	QFM	SIA	6	2500	330.0	12.4	3.5	5.3	1.3	8.0	12.0	Q1
LMK62E2-100M00SIAT	QFM	SIA	6	250	180.0	12.4	3.5	5.3	1.3	8.0	12.0	Q1
LMK62E2-156M25SIAR	QFM	SIA	6	2500	330.0	12.4	3.5	5.3	1.3	8.0	12.0	Q1
LMK62E2-156M25SIAT	QFM	SIA	6	250	180.0	12.4	3.5	5.3	1.3	8.0	12.0	Q1

Device	Package Type	Package Drawing	Pins	SPQ	Reel Diameter (mm)	Reel Width W1 (mm)	A0 (mm)	B0 (mm)	K0 (mm)	P1 (mm)	W (mm)	Pin1 Quadrant
LMK6210-100M00SIAR	QFM	SIA	6	2500	330.0	12.4	3.5	5.3	1.3	8.0	12.0	Q1
LMK6210-100M00SIAT	QFM	SIA	6	250	180.0	12.4	3.5	5.3	1.3	8.0	12.0	Q1
LMK6210-156M25SIAR	QFM	SIA	6	2500	330.0	12.4	3.5	5.3	1.3	8.0	12.0	Q1
LMK6210-156M25SIAT	QFM	SIA	6	250	180.0	12.4	3.5	5.3	1.3	8.0	12.0	Q1

TAPE AND REEL BOX DIMENSIONS

*All dimensions are nominal

Device	Package Type	Package Drawing	Pins	SPQ	Length (mm)	Width (mm)	Height (mm)
LMK62A2-100M00SIAR	QFM	SIA	6	2500	367.0	367.0	35.0
LMK62A2-100M00SIAT	QFM	SIA	6	250	210.0	185.0	35.0
LMK62A2-150M00SIAR	QFM	SIA	6	2500	346.0	346.0	33.0
LMK62A2-150M00SIAT	QFM	SIA	6	250	210.0	185.0	35.0
LMK62A2-156M25SIAR	QFM	SIA	6	2500	346.0	346.0	33.0
LMK62A2-156M25SIAT	QFM	SIA	6	250	210.0	185.0	35.0
LMK62A2-200M00SIAR	QFM	SIA	6	2500	346.0	346.0	33.0
LMK62A2-200M00SIAT	QFM	SIA	6	250	210.0	185.0	35.0
LMK62A2-266M66SIAR	QFM	SIA	6	2500	367.0	367.0	35.0
LMK62A2-266M66SIAT	QFM	SIA	6	250	210.0	185.0	35.0
LMK62E0-156M25SIAR	QFM	SIA	6	2500	367.0	367.0	35.0
LMK62E0-156M25SIAT	QFM	SIA	6	250	210.0	185.0	35.0
LMK62E2-100M00SIAR	QFM	SIA	6	2500	346.0	346.0	33.0
LMK62E2-100M00SIAT	QFM	SIA	6	250	210.0	185.0	35.0
LMK62E2-156M25SIAR	QFM	SIA	6	2500	346.0	346.0	33.0
LMK62E2-156M25SIAT	QFM	SIA	6	250	210.0	185.0	35.0
LMK62I0-100M00SIAR	QFM	SIA	6	2500	346.0	346.0	33.0
LMK62I0-100M00SIAT	QFM	SIA	6	250	210.0	185.0	35.0

Device	Package Type	Package Drawing	Pins	SPQ	Length (mm)	Width (mm)	Height (mm)
LMK6210-156M25SIAR	QFM	SIA	6	2500	346.0	346.0	33.0
LMK6210-156M25SIAT	QFM	SIA	6	250	210.0	185.0	35.0

IMPORTANT NOTICE AND DISCLAIMER

TI PROVIDES TECHNICAL AND RELIABILITY DATA (INCLUDING DATA SHEETS), DESIGN RESOURCES (INCLUDING REFERENCE DESIGNS), APPLICATION OR OTHER DESIGN ADVICE, WEB TOOLS, SAFETY INFORMATION, AND OTHER RESOURCES "AS IS" AND WITH ALL FAULTS, AND DISCLAIMS ALL WARRANTIES, EXPRESS AND IMPLIED, INCLUDING WITHOUT LIMITATION ANY IMPLIED WARRANTIES OF MERCHANTABILITY, FITNESS FOR A PARTICULAR PURPOSE OR NON-INFRINGEMENT OF THIRD PARTY INTELLECTUAL PROPERTY RIGHTS.

These resources are intended for skilled developers designing with TI products. You are solely responsible for (1) selecting the appropriate TI products for your application, (2) designing, validating and testing your application, and (3) ensuring your application meets applicable standards, and any other safety, security, regulatory or other requirements.

These resources are subject to change without notice. TI grants you permission to use these resources only for development of an application that uses the TI products described in the resource. Other reproduction and display of these resources is prohibited. No license is granted to any other TI intellectual property right or to any third party intellectual property right. TI disclaims responsibility for, and you will fully indemnify TI and its representatives against, any claims, damages, costs, losses, and liabilities arising out of your use of these resources.

TI's products are provided subject to [TI's Terms of Sale](#) or other applicable terms available either on [ti.com](https://www.ti.com) or provided in conjunction with such TI products. TI's provision of these resources does not expand or otherwise alter TI's applicable warranties or warranty disclaimers for TI products.

TI objects to and rejects any additional or different terms you may have proposed.

Mailing Address: Texas Instruments, Post Office Box 655303, Dallas, Texas 75265
Copyright © 2023, Texas Instruments Incorporated

Looking for pricing, stock, or lifecycle information?

Click below to explore more details on WIN SOURCE:

- ⊖ [View MAX6501UKP125 on WIN SOURCE](#)
- ⊖ [Maxim Integrated Information](#)

Optimize Your Supply Chain with WIN SOURCE Solutions

- ✓ Global Sourcing Solution
- ✓ Obsolete Management
- ✓ Cost Control Management
- ✓ Shortage Management
- ✓ Alternative Solution
- ✓ Excess Inventory Management