



**THE DATASHEET OF  
ADF7020BCPZ-RL**



## FEATURES

Low power, low IF transceiver

Frequency bands

431 MHz to 478 MHz

862 MHz to 956 MHz

Data rates supported

0.15 kbps to 200 kbps, FSK

0.15 kbps to 64 kbps, ASK

2.3 V to 3.6 V power supply

Programmable output power

-16 dBm to +13 dBm in 0.3 dBm steps

Receiver sensitivity

-119 dBm at 1 kbps, FSK

-112 dBm at 9.6 kbps, FSK

-106.5 dBm at 9.6 kbps, ASK

Low power consumption

19 mA in receive mode

26.8 mA in transmit mode (10 dBm output)

-3 dBm IIP3 in high linearity mode

On-chip VCO and fractional-N PLL

On-chip 7-bit ADC and temperature sensor

Fully automatic frequency control loop (AFC) compensates for  $\pm 25$  ppm crystal at 862 MHz to 956 MHz or  $\pm 50$  ppm at 431 MHz to 478 MHz

Digital RSSI

Integrated Tx/Rx switch

Leakage current of  $< 1 \mu\text{A}$  in power-down mode

## APPLICATIONS

Low cost wireless data transfer

Remote control/security systems

Wireless metering

Keyless entry

Home automation

Process and building control

Wireless voice

## FUNCTIONAL BLOCK DIAGRAM

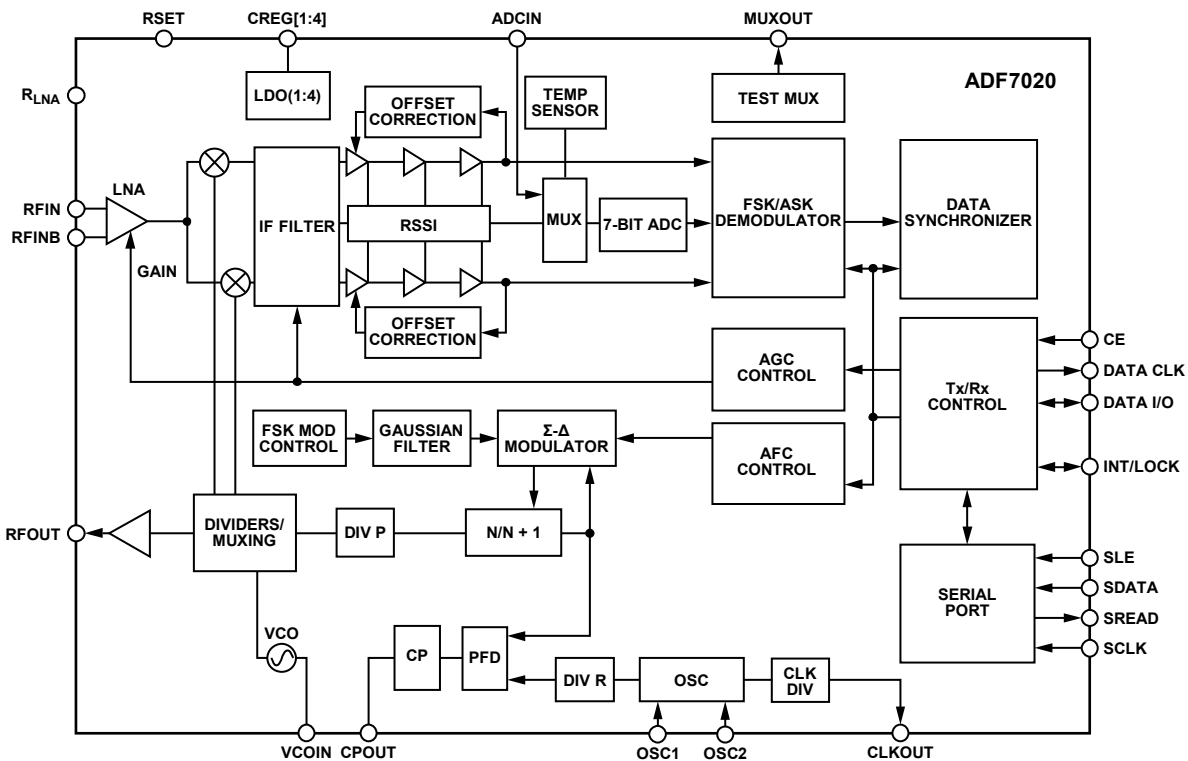

Figure 1.

06351-001

Rev. E

[Document Feedback](#)

Information furnished by Analog Devices is believed to be accurate and reliable. However, no responsibility is assumed by Analog Devices for its use, nor for any infringements of patents or other rights of third parties that may result from its use. Specifications subject to change without notice. No license is granted by implication or otherwise under any patent or patent rights of Analog Devices. Trademarks and registered trademarks are the property of their respective owners.

One Technology Way, P.O. Box 9106, Norwood, MA 02062-9106, U.S.A.  
Tel: 781.329.4700 ©2005–2016 Analog Devices, Inc. All rights reserved.  
[Technical Support](#) [www.analog.com](http://www.analog.com)

## TABLE OF CONTENTS

Features .....	1	Transmit Protocol and Coding Considerations .....	27
Applications .....	1	Device Programming after Initial Power-Up .....	27
Functional Block Diagram .....	1	Interfacing to Microcontroller/DSP .....	27
Revision History .....	3	Power Consumption and battery lifetime calculations .....	28
General Description .....	4	Serial Interface .....	31
Specifications .....	5	Readback Format .....	31
Timing Characteristics .....	8	Registers .....	32
Timing Diagrams .....	8	Register 0—N Register .....	32
Absolute Maximum Ratings .....	10	Register 1—Oscillator/Filter Register .....	33
ESD Caution .....	10	Register 2—Transmit Modulation Register (ASK/OOK Mode) .....	34
Pin Configuration and Function Descriptions .....	11	Register 2—Transmit Modulation Register (FSK Mode) .....	35
Typical Performance Characteristics .....	13	Register 2—Transmit Modulation Register (GFSK/GOOK Mode) .....	36
Frequency Synthesizer .....	15	Register 3—Receiver Clock Register .....	37
Reference Input .....	15	Register 4—Demodulator Setup Register .....	38
Choosing Channels for Best System Performance .....	17	Register 5—Sync Byte Register .....	39
Transmitter .....	18	Register 6—Correlator/Demodulator Register .....	40
RF Output Stage .....	18	Register 7—Readback Setup Register .....	41
Modulation Schemes .....	18	Register 8—Power-Down Test Register .....	42
Receiver .....	20	Register 9—AGC Register .....	43
RF Front End .....	20	Register 10—AGC 2 Register .....	44
RSSI/AGC .....	21	Register 11—AFC Register .....	44
FSK Demodulators on the ADF7020 .....	21	Register 12—Test Register .....	45
FSK Correlator/Demodulator .....	21	Register 13—Offset Removal and Signal Gain Register .....	46
Linear FSK Demodulator .....	23	Outline Dimensions .....	47
AFC .....	23	Ordering Guide .....	47
Automatic Sync Word Recognition .....	24		
Applications Information .....	25		
LNA/PA Matching .....	25		
Image Rejection Calibration .....	26		

**REVISION HISTORY****9/2016—Rev. D to Rev. E**

Changes to General Description Section .....	4
Changes to Interfacing to Microcontroller/DSP Section and Figure 37 .....	27

**8/2012—Rev. C to Rev. D**

Added EPAD Notation .....	11
Changed CP-48-3 Package to CP-48-5 Package.....	47
Updated Outline Dimensions.....	47
Changes to Ordering Guide.....	47

**5/2011—Rev. B to Rev. C**

Added Exposed Pad Notation to Outline Dimensions .....	47
Changes to Ordering Guide.....	47

**8/2007—Rev. A to Rev. B**

Changes to Features .....	1
Changes to General Description .....	4
Changes to Table 1 .....	5
Changes to Table 2 .....	8
Changes to Reference Input Section.....	15
Changes to N Counter Section .....	16
Changes to Choosing Channels for Best Performance Section	17
Changes to Table 5 .....	20
Changes to FSK Correlator Register Settings Section .....	22
Added Image Rejection Calibration Section .....	26
Added Figure 41 .....	30
Changes to Readback Format Section.....	31
Changes to Register 9—AGC Register Comments Section.....	43
Added Register 12—Test Register Comments Section .....	45

**4/2006—Rev. 0 to Rev. A**

Changes to Features .....	1
Changes to Table 1 .....	5
Changes to Figure 24 .....	17
Changes to the Setting Up the ADF7020 for GFSK Section .....	19
Changes to Table 6 .....	21
Changes to Table 9 .....	23
Changes to External AFC Section.....	23
Deleted Maximum AFC Range Section .....	23
Added AFC Performance Section.....	24
Changes to Internal Rx/Tx Switch Section .....	25
Changes to Figure 32 .....	25
Changes to Transmit Protocol and Coding Considerations Section .....	26
Added Text Relating to Figure 37 .....	27
Changes to Figure 41 .....	31
Changes to Register 1—Oscillator/Filter Register Comments.....	31
Changes to Figure 42 .....	32
Changes to Register 2—Transmit Modulation Register (FSK Mode) Comments .....	33
Changes to Figure 44 .....	34
Changes to Register 2—Transmit Modulation Register (GFSK/GOOK Mode) Comments .....	34
Changes to Register 4—Demodulator Setup Register Comments.....	36
Changes to Figure 51 .....	41
Changes to Figure 53 .....	42
Changes to Ordering Guide.....	45

**6/2005—Revision 0: Initial Version**

## GENERAL DESCRIPTION

The [ADF7020](#) is a low power, highly integrated FSK/ASK/OOK transceiver designed for operation in the license-free ISM bands at 433 MHz, 868 MHz, and 915 MHz, as well as the proposed Japanese RFID band at 950 MHz. A Gaussian data filter option is available to allow either GFSK or G-ASK modulation, which provides a more spectrally efficient modulation. In addition to these modulation options, the [ADF7020](#) can also be used to perform both MSK and GMSK modulation, where MSK is a special case of FSK with a modulation index of 0.5. The modulation index is calculated as twice the deviation divided by the data rate. MSK is spectrally equivalent to O-QPSK modulation with half-sinusoidal Tx baseband shaping, so the [ADF7020](#) can also support this modulation option by setting up the device in MSK mode.

This device is suitable for circuit applications that meet the European ETSI-300-220, the North American FCC (Part 15), or the Chinese Short Range Device regulatory standards. A complete transceiver can be built using a small number of external discrete components, making the [ADF7020](#) very suitable for price-sensitive and area-sensitive applications.

The transmitter block on the [ADF7020](#) contains a VCO and low noise fractional-N PLL with an output resolution of <1 ppm. This frequency agile PLL allows the [ADF7020](#) to be used in frequency-hopping spread spectrum (FHSS) systems. The VCO operates at twice the fundamental frequency to reduce spurious emissions and frequency-pulling problems.

The transmitter output power is programmable in 0.3 dB steps from -16 dBm to +13 dBm. The transceiver RF frequency and modulation are programmable using a simple 3-wire interface. The device operates with a power supply range of 2.3 V to 3.6 V and can be powered down when not in use.

A low IF architecture is used in the receiver (200 kHz), minimizing power consumption and the external component count and avoiding interference problems at low frequencies. The [ADF7020](#) supports a wide variety of programmable features, including Rx linearity, sensitivity, and IF bandwidth, allowing the user to trade off receiver sensitivity and selectivity against current consumption, depending on the application. The receiver also features a patent-pending automatic frequency control (AFC) loop, allowing the PLL to track out the frequency error in the incoming signal.

An on-chip ADC provides readback of an integrated temperature sensor, an external analog input, the battery voltage, or the RSSI signal, which provides savings on an ADC in some applications. The temperature sensor is accurate to  $\pm 10^{\circ}\text{C}$  over the full operating temperature range of  $-40^{\circ}\text{C}$  to  $+85^{\circ}\text{C}$ . This accuracy can be improved by doing a 1-point calibration at room temperature and storing the result in memory.

## SPECIFICATIONS

VDD = 2.3 V to 3.6 V, GND = 0 V, T<sub>A</sub> = T<sub>MIN</sub> to T<sub>MAX</sub>, unless otherwise noted. Typical specifications are at VDD = 3 V, T<sub>A</sub> = 25°C. All measurements are performed using the [EVAL-ADF7020DBZ1](#) through [EVAL-ADF7020DBZ3](#) using the PN9 data sequence, unless otherwise noted.

Table 1.

Parameter	Min	Typ	Max	Unit	Test Conditions
<b>RF CHARACTERISTICS</b>					
Frequency Ranges (Direct Output)	862		870	MHz	VCO adjust = 0, VCO bias = 10
	902		928	MHz	VCO adjust = 3, VCO bias = 10
	928		956	MHz	VCO adjust = 3, VCO bias = 12, VDD = 2.7 V to 3.6 V
Frequency Ranges (Divide-by-2 Mode)	431		440	MHz	VCO adjust = 0, VCO bias = 10
	440		478	MHz	VCO adjust = 3, VCO bias = 12
Phase Frequency Detector Frequency	RF/256		24	MHz	
<b>TRANSMISSION PARAMETERS</b>					
Data Rate					
FSK/GFSK	0.15		200	kbps	
OOK/ASK	0.15		64 <sup>1</sup>	kbps	
OOK/ASK	0.3		100	kbaud	Using Manchester encoding
Frequency Shift Keying					
GFSK/FSK Frequency Deviation <sup>2,3</sup>	1		110	kHz	PFD = 3.625 MHz
	4.88		620	kHz	PFD = 20 MHz
Deviation Frequency Resolution	100			Hz	PFD = 3.625 MHz
Gaussian Filter BT		0.5			
Amplitude Shift Keying					
ASK Modulation Depth			30	dB	
PA Off Feedthrough in OOK Mode		-50		dBm	
Transmit Power <sup>4</sup>	-20		+13	dBm	VDD = 3.0 V, T <sub>A</sub> = 25°C
Transmit Power Variation vs. Temperature		±1		dB	From -40°C to +85°C
Transmit Power Variation vs. VDD		±1		dB	From 2.3 V to 3.6 V at 915 MHz, T <sub>A</sub> = 25°C
Transmit Power Flatness		±1		dB	From 902 MHz to 928 MHz, 3 V, T <sub>A</sub> = 25°C
Programmable Step Size					
-20 dBm to +13 dBm		0.3125		dB	
Integer Boundary Reference		-55		dBc	50 kHz loop BW
		-65		dBc	
Harmonics					
Second Harmonic		-27		dBc	Unfiltered conductive
Third Harmonic		-21		dBc	
All Other Harmonics		-35		dBc	
VCO Frequency Pulling, OOK Mode		30		kHz rms	DR = 9.6 kbps
Optimum PA Load Impedance <sup>5</sup>		39 + j61		Ω	FRF = 915 MHz
		48 + j54		Ω	FRF = 868 MHz
		54 + j94		Ω	FRF = 433 MHz
<b>RECEIVER PARAMETERS</b>					
FSK/GFSK Input Sensitivity					At BER = 1E - 3, FRF = 915 MHz, LNA and PA matched separately <sup>6</sup>
Sensitivity at 1 kbps		-119.2		dBm	FDEV = 5 kHz, high sensitivity mode <sup>7</sup>
Sensitivity at 9.6 kbps		-112.8		dBm	FDEV = 10 kHz, high sensitivity mode
Sensitivity at 200 kbps		-100		dBm	FDEV = 50 kHz, high sensitivity mode
OOK Input Sensitivity					At BER = 1E - 3, FRF = 915 MHz
Sensitivity at 1 kbps		-116		dBm	High sensitivity mode
Sensitivity at 9.6 kbps		-106.5		dBm	High sensitivity mode

Parameter	Min	Typ	Max	Unit	Test Conditions
LNA and Mixer, Input IP3 <sup>7</sup>					
Enhanced Linearity Mode		-3		dBm	Pin = -20 dBm, 2 CW interferers FRF = 915 MHz, F1 = FRF + 3 MHz F2 = FRF + 6 MHz, maximum gain <1 GHz at antenna input >1 GHz at antenna input
Low Current Mode		-5		dBm	
High Sensitivity Mode		-24		dBm	
Rx Spurious Emissions <sup>8</sup>			-57	dBm	
			-47	dBm	
AFC					
Pull-In Range at 868 MHz/915 MHz		±50		kHz	IF_BW = 200 kHz
Pull-In Range at 433 MHz		±25		kHz	IF_BW = 200 kHz
Response Time		48		Bits	Modulation index = 0.875
Accuracy		1		kHz	
CHANNEL FILTERING					Desired signal 3 dB above the input sensitivity level, CW interferer power level increased until BER = 10 <sup>-3</sup> , image channel excluded
Adjacent Channel Rejection (Offset = ±1 × IF Filter BW Setting)		27		dB	IF filter BW settings = 100 kHz, 150 kHz, 200 kHz
Second Adjacent Channel Rejection (Offset = ±2 × IF Filter BW Setting)		50		dB	IF filter BW settings = 100 kHz, 150 kHz, 200 kHz
Third Adjacent Channel Rejection (Offset = ±3 × IF Filter BW Setting)		55		dB	IF filter BW settings = 100 kHz, 150 kHz, 200 kHz
Image Channel Rejection (Uncalibrated)		30		dB	Image at FRF = 400 kHz
Image Channel Rejection (Calibrated)		50		dB	Image at FRF = 400 kHz
CO-CHANNEL REJECTION		-2		dB	
Wideband Interference Rejection		70		dB	Swept from 100 MHz to 2 GHz, measured as channel rejection
BLOCKING					Desired signal 3 dB above the input sensitivity level, CW interferer power level increased until BER = 10 <sup>-2</sup>
±1 MHz		60		dB	FSK mode, BER = 10 <sup>-3</sup> FRF = 915 MHz, RFIN to GND FRF = 868 MHz FRF = 433 MHz
±5 MHz		68		dB	
±10 MHz		65		dB	
±10 MHz (High Linearity Mode)		72		dB	
Saturation (Maximum Input Level)		12		dBm	
LNA Input Impedance		24 - j60		Ω	
		26 - j63		Ω	
		71 - j128		Ω	
RSSI					
Range at Input		-110 to -24		dBm	
Linearity		±2		dB	
Absolute Accuracy		±3		dB	
Response Time		150		μs	See the RSSI/AGC section
PHASE-LOCKED LOOP					
VCO Gain		65		MHz/V	902 MHz to 928 MHz band, VCO adjust = 0, VCO_BIAS_SETTING = 10
		130		MHz/V	860 MHz to 870 MHz band, VCO adjust = 0
		65		MHz/V	433 MHz, VCO adjust = 0
Phase Noise (In-Band)		-89		dBc/Hz	PA = 0 dBm, VDD = 3.0 V, PFD = 10 MHz, FRF = 915 MHz, VCO_BIAS_SETTING = 10
Phase Noise (Out-of-Band)		-110		dBc/Hz	1 MHz offset
Residual FM		128		Hz	From 200 Hz to 20 kHz, FRF = 868 MHz
PLL Settling		40		μs	Measured for a 10 MHz frequency step to within 5 ppm accuracy, PFD = 20 MHz, LBW = 50 kHz

Parameter	Min	Typ	Max	Unit	Test Conditions
REFERENCE INPUT					
Crystal Reference	3.625		24	MHz	See crystal manufacturer's specification sheet 11.0592 MHz crystal, using 33 pF load capacitors Using 16 pF load capacitors See the Reference Input section
External Oscillator	3.625		24	MHz	
Load Capacitance		33		pF	
Crystal Start-Up Time		2.1		ms	
Input Level		1.0		ms CMOS levels	
ADC PARAMETERS					
INL		±1		LSB	From 2.3 V to 3.6 V, T <sub>A</sub> = 25°C
DNL		±1		LSB	From 2.3 V to 3.6 V, T <sub>A</sub> = 25°C
TIMING INFORMATION					
Chip Enabled to Regulator Ready		10		μs	C <sub>REG</sub> = 100 nF
Chip Enabled to RSSI Ready		3.0		ms	See Table 11 for more details
Tx to Rx Turnaround Time		150 μs + (5 × T <sub>BIT</sub> )			Time to synchronized data out, includes AGC settling; see the AGC Information and Timing section
LOGIC INPUTS					
Input High Voltage, V <sub>INH</sub>	0.7 × VDD			V	
Input Low Voltage, V <sub>INL</sub>			0.2 × VDD	V	
Input Current, I <sub>INH</sub> /I <sub>INL</sub>			±1	μA	
Input Capacitance, C <sub>IN</sub>			10	pF	
Control Clock Input			50	MHz	
LOGIC OUTPUTS					
Output High Voltage, V <sub>OH</sub>	DVDD – 0.4			V	I <sub>OH</sub> = 500 μA
Output Low Voltage, V <sub>OL</sub>			0.4	V	I <sub>OL</sub> = 500 μA
CLK <sub>OUT</sub> Rise/Fall			5	ns	
CLK <sub>OUT</sub> Load			10	pF	
TEMPERATURE RANGE, T <sub>A</sub>	–40		+85	°C	
POWER SUPPLIES					
Voltage Supply VDD	2.3		3.6	V	All VDD pins must be tied together
Transmit Current Consumption					FRF = 915 MHz, VDD = 3.0 V, PA is matched to 50 Ω
–20 dBm		14.8		mA	Combined PA and LNA matching network as on <a href="#">EVAL-ADF7020DBZ1</a> through <a href="#">EVAL-ADF7020DBZ3</a> boards, VCO_BIAS_SETTING = 12
–10 dBm		15.9		mA	
0 dBm		19.1		mA	
10 dBm		28.5		mA	
10 dBm		26.8		mA	
Receive Current Consumption					PA matched separately with external antenna switch, VCO_BIAS_SETTING = 12
Low Current Mode		19		mA	
High Sensitivity Mode		21		mA	
Power-Down Mode					
Low Power Sleep Mode		0.1	1	μA	

<sup>1</sup> Higher data rates are achievable, depending on local regulations.

<sup>2</sup> For the definition of frequency deviation, see the Register 2—Transmit Modulation Register (FSK Mode) section.

<sup>3</sup> For the definition of GFSK frequency deviation, see the Register 2—Transmit Modulation Register (GFSK/GOOK Mode) section.

<sup>4</sup> Measured as maximum unmodulated power. Output power varies with both supply and temperature.

<sup>5</sup> For matching details, see the LNA/PA Matching section and the [AN-764 Application Note](#).

<sup>6</sup> Sensitivity for combined matching network case is typically 2 dB less than separate matching networks.

<sup>7</sup> See Table 5 for a description of different receiver modes.

<sup>8</sup> Follow the matching and layout guidelines to achieve the relevant FCC/ETSI specifications.

### TIMING CHARACTERISTICS

VDD = 3 V ± 10%, VGND = 0 V, TA = 25°C, unless otherwise noted. Guaranteed by design, not production tested.

Table 2.

Parameter	Limit at T <sub>MIN</sub> to T <sub>MAX</sub>	Unit	Test Conditions/Comments
t <sub>1</sub>	>10	ns	SDATA to SCLK setup time
t <sub>2</sub>	>10	ns	SDATA to SCLK hold time
t <sub>3</sub>	>25	ns	SCLK high duration
t <sub>4</sub>	>25	ns	SCLK low duration
t <sub>5</sub>	>10	ns	SCLK to SLE setup time
t <sub>6</sub>	>20	ns	SLE pulse width
t <sub>8</sub>	<25	ns	SCLK to SREAD data valid, readback
t <sub>9</sub>	<25	ns	SREAD hold time after SCLK, readback
t <sub>10</sub>	>10	ns	SCLK to SLE disable time, readback

### TIMING DIAGRAMS

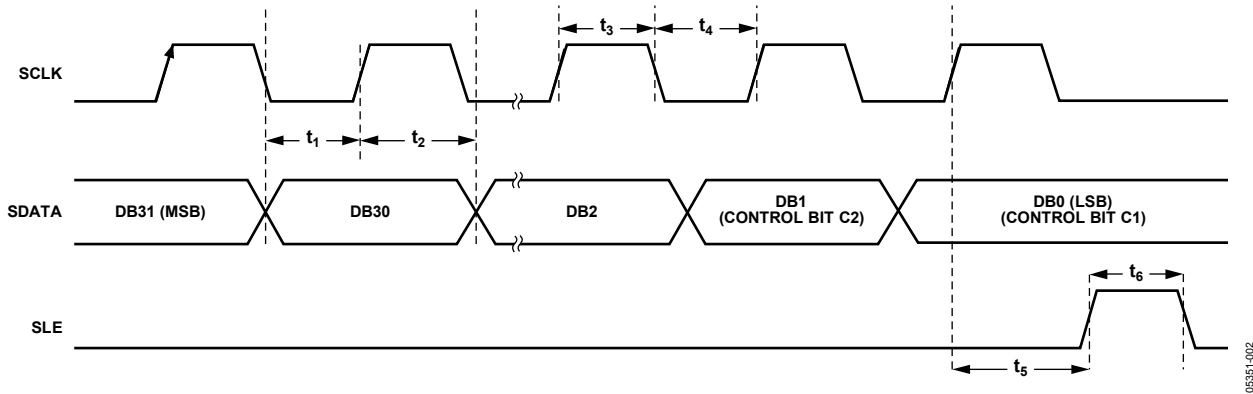

Figure 2. Serial Interface Timing Diagram

05351-002

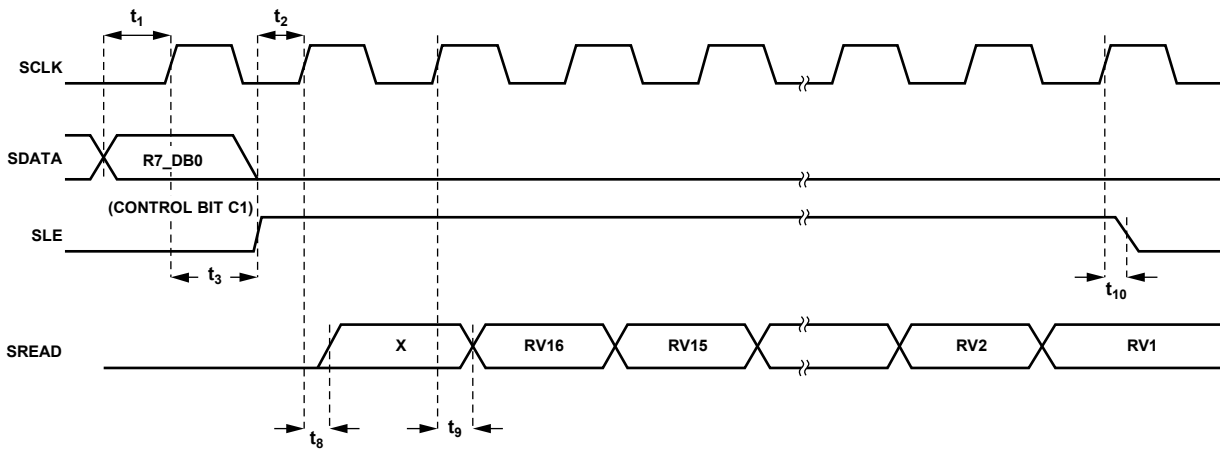

Figure 3. Readback Timing Diagram

05351-003

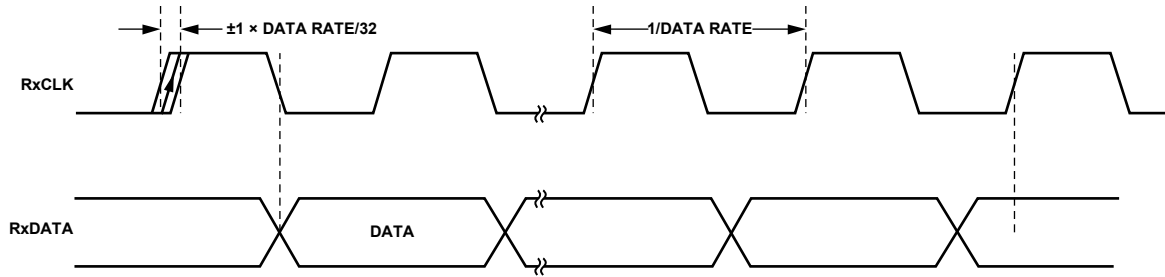
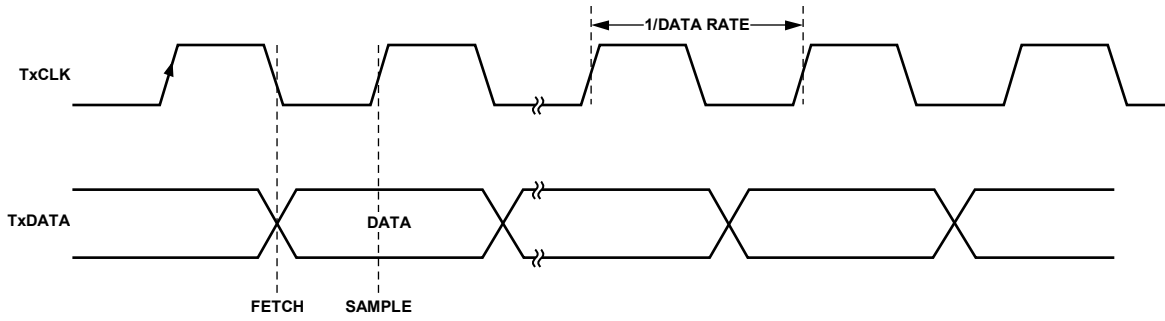

Figure 4. RxData/RxCLK Timing Diagram

05351-004



NOTES  
1. TxCLK ONLY AVAILABLE IN GFSK MODE.

Figure 5. TxData/TxCLK Timing Diagram

05351-005

## ABSOLUTE MAXIMUM RATINGS

$T_A = 25^\circ\text{C}$ , unless otherwise noted.

Table 3.

Parameter	Rating
VDD to GND <sup>1</sup>	-0.3 V to +5 V
Analog I/O Voltage to GND	-0.3 V to AVDD + 0.3 V
Digital I/O Voltage to GND	-0.3 V to DVDD + 0.3 V
Operating Temperature Range	
Industrial (B Version)	-40°C to +85°C
Storage Temperature Range	-65°C to +125°C
Maximum Junction Temperature	150°C
MLF $\theta_{JA}$ Thermal Impedance	26°C/W
Reflow Soldering	
Peak Temperature	260°C
Time at Peak Temperature	40 sec

<sup>1</sup> GND = GND1 = RFGND = GND4 = VCO GND = 0 V.

Stresses at or above those listed under Absolute Maximum Ratings may cause permanent damage to the product. This is a stress rating only; functional operation of the product at these or any other conditions above those indicated in the operational section of this specification is not implied. Operation beyond the maximum operating conditions for extended periods may affect product reliability.

This device is a high performance RF integrated circuit with an ESD rating of <2 kV, and is ESD sensitive. Proper precautions should be taken for handling and assembly.

### ESD CAUTION



**ESD (electrostatic discharge) sensitive device.** Charged devices and circuit boards can discharge without detection. Although this product features patented or proprietary protection circuitry, damage may occur on devices subjected to high energy ESD. Therefore, proper ESD precautions should be taken to avoid performance degradation or loss of functionality.

# PIN CONFIGURATION AND FUNCTION DESCRIPTIONS

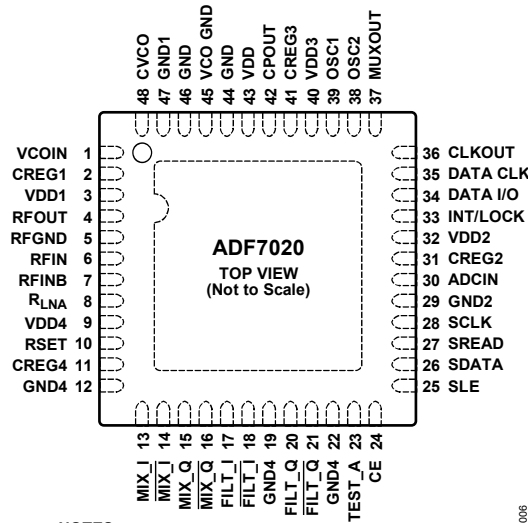

NOTES  
 1. EXPOSED PAD MUST BE CONNECTED TO GROUND.

Figure 6. Pin Configuration

Table 4. Pin Function Descriptions

Pin No.	Mnemonic	Description
1	VCOIN	The tuning voltage on this pin determines the output frequency of the voltage-controlled oscillator (VCO). The higher the tuning voltage, the higher the output frequency.
2	CREG1	Regulator Voltage for PA Block. A 100 nF in parallel with a 5.1 pF capacitor should be placed between this pin and ground for regulator stability and noise rejection.
3	VDD1	Voltage Supply for PA Block. Decoupling capacitors of 0.1 μF and 10 pF should be placed as close as possible to this pin. All VDD pins should be tied together.
4	RFOUT	The modulated signal is available at this pin. Output power levels are from -20 dBm to +13 dBm. The output should be impedance matched to the desired load using suitable components. See the Transmitter section.
5	RFGND	Ground for Output Stage of Transmitter. All GND pins should be tied together.
6	RFIN	LNA Input for Receiver Section. Input matching is required between the antenna and the differential LNA input to ensure maximum power transfer. See the LNA/PA Matching section.
7	RFINB	Complementary LNA Input. See the LNA/PA Matching section.
8	R <sub>LNA</sub>	External bias resistor for LNA. Optimum resistor is 1.1 kΩ with 5% tolerance.
9	VDD4	Voltage Supply for LNA/MIXER Block. This pin should be decoupled to ground with a 10 nF capacitor.
10	RSET	External Resistor to Set Charge Pump Current and Some Internal Bias Currents. Use 3.6 kΩ with 5% tolerance.
11	CREG4	Regulator Voltage for LNA/MIXER Block. A 100 nF capacitor should be placed between this pin and GND for regulator stability and noise rejection.
12	GND4	Ground for LNA/MIXER Block.
13 to 18	MIX_I, <u>MIX_I</u> , MIX_Q, <u>MIX_Q</u> , FILT_I, <u>FILT_I</u>	Signal Chain Test Pins. These pins are high impedance under normal conditions and should be left unconnected.
19, 22	GND4	Ground for LNA/MIXER Block.
20, 21, 23	FILT_Q, <u>FILT_Q</u> , TEST_A	Signal Chain Test Pins. These pins are high impedance under normal conditions and should be left unconnected.
24	CE	Chip Enable. Bringing CE low puts the <a href="#">ADF7020</a> into complete power-down. Register values are lost when CE is low, and the part must be reprogrammed once CE is brought high.
25	SLE	Load Enable, CMOS Input. When LE goes high, the data stored in the shift registers is loaded into one of the fourteen latches. A latch is selected using the control bits.
26	SDATA	Serial Data Input. The serial data is loaded MSB first with the two LSBs as the control bits. This pin is a high impedance CMOS input.

Pin No.	Mnemonic	Description
27	SREAD	Serial Data Output. This pin is used to feed readback data from the <a href="#">ADF7020</a> to the microcontroller. The SCLK input is used to clock each readback bit (AFC, ADC readback) from the SREAD pin.
28	SCLK	Serial Clock Input. This serial clock is used to clock in the serial data to the registers. The data is latched into the 24-bit shift register on the CLK rising edge. This pin is a digital CMOS input.
29	GND2	Ground for Digital Section.
30	ADCIN	Analog-to-Digital Converter Input. The internal 7-bit ADC can be accessed through this pin. Full scale is 0 V to 1.9 V. Readback is made using the SREAD pin.
31	CREG2	Regulator Voltage for Digital Block. A 100 nF in parallel with a 5.1 pF capacitor should be placed between this pin and ground for regulator stability and noise rejection.
32	VDD2	Voltage Supply for Digital Block. A decoupling capacitor of 10 nF should be placed as close as possible to this pin.
33	INT/LOCK	Bidirectional Pin. In output mode (interrupt mode), the <a href="#">ADF7020</a> asserts the INT/ LOCK pin when it has found a match for the preamble sequence. In input mode (lock mode), the microcontroller can be used to lock the demodulator threshold when a valid preamble has been detected. Once the threshold is locked, NRZ data can be reliably received. In this mode, a demodulation lock can be asserted with minimum delay.
34	DATA I/O	Transmit Data Input/Received Data Output. This is a digital pin, and normal CMOS levels apply.
35	DATA CLK	In receive mode, the pin outputs the synchronized data clock. The positive clock edge is matched to the center of the received data. In GFSK transmit mode, the pin outputs an accurate clock to latch the data from the microcontroller into the transmit section at the exact required data rate. See the Gaussian Frequency Shift Keying (GFSK) section.
36	CLKOUT	A Divided-Down Version of the Crystal Reference with Output Driver. The digital clock output can be used to drive several other CMOS inputs, such as a microcontroller clock. The output has a 50:50 mark-space ratio.
37	MUXOUT	This pin provides the LOCK_DETECT signal, which is used to determine if the PLL is locked to the correct frequency. Other signals include REGULATOR_READY, which is an indicator of the status of the serial interface regulator.
38	OSC2	The reference crystal should be connected between this pin and OSC1. A TCXO reference can be used by driving this pin with CMOS levels and disabling the crystal oscillator.
39	OSC1	The reference crystal should be connected between this pin and OSC2.
40	VDD3	Voltage Supply for the Charge Pump and PLL Dividers. This pin should be decoupled to ground with a 0.01 $\mu$ F capacitor.
41	CREG3	Regulator Voltage for Charge Pump and PLL Dividers. A 100 nF in parallel with a 5.1 pF capacitor should be placed between this pin and ground for regulator stability and noise rejection.
42	CPOUT	Charge Pump Output. This output generates current pulses that are integrated in the loop filter. The integrated current changes the control voltage on the input to the VCO.
43	VDD	Voltage Supply for VCO Tank Circuit. This pin should be decoupled to ground with a 0.01 $\mu$ F capacitor.
44 to 47	GND, GND1, VCO GND	Grounds for VCO Block.
48	CVCO EP	A 22 nF capacitor should be placed between this pin and CREG1 to reduce VCO noise. Exposed Pad. The exposed pad must be connected to ground.

# TYPICAL PERFORMANCE CHARACTERISTICS

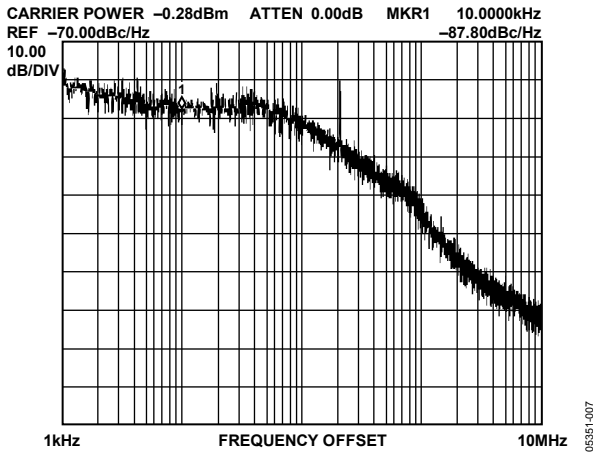

Figure 7. Phase Noise Response at 868.3 MHz, VDD = 3.0 V, ICP = 1.5 mA

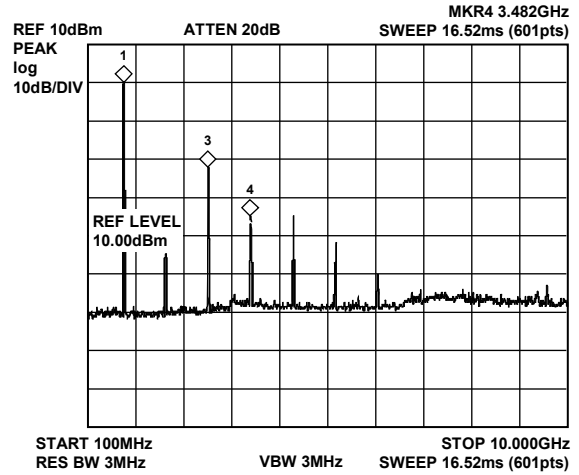

Figure 10. Harmonic Response, R<sub>FOUT</sub> Matched to 50 Ω, No Filter

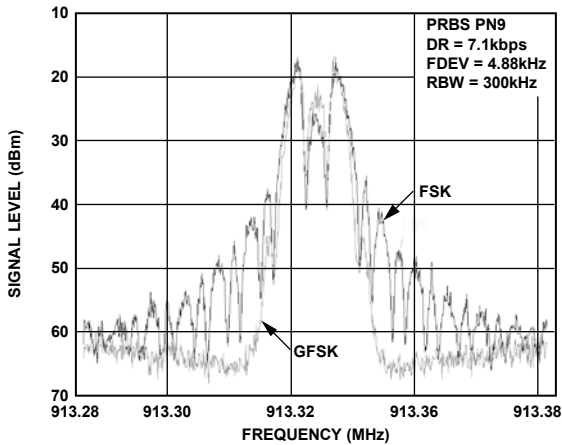

Figure 8. Output Spectrum in FSK and GFSK Modulation

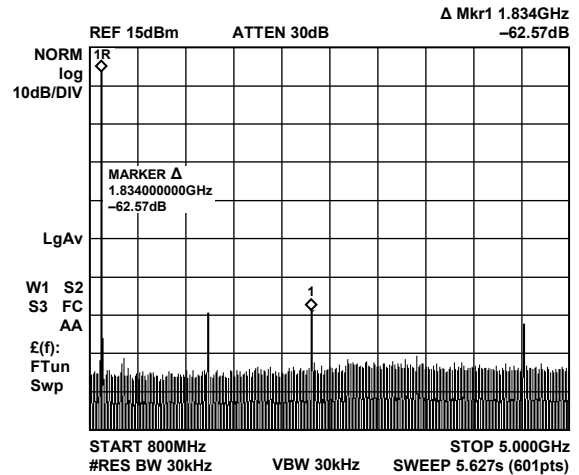

Figure 11. Harmonic Response, Murata Dielectric Filter

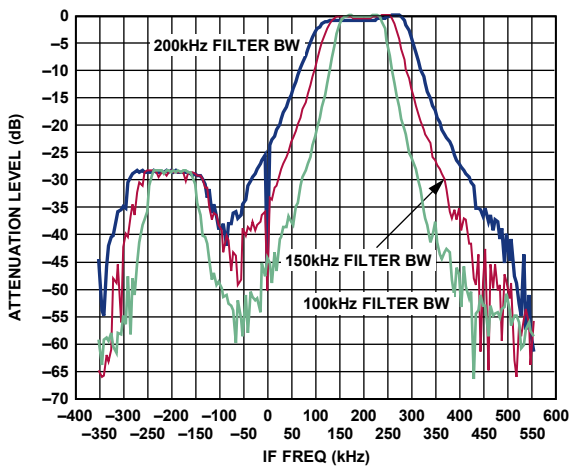

Figure 9. IF Filter Response

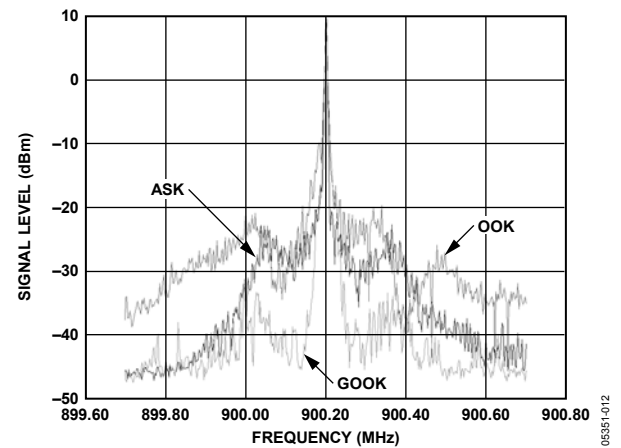

Figure 12. Output Spectrum in ASK, OOK, and GOOK Modes, DR = 10 kbps

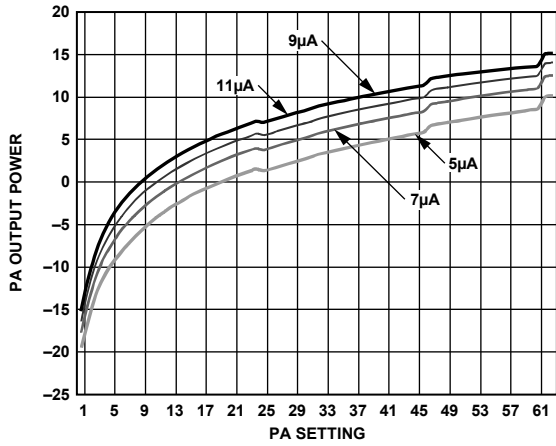

Figure 13. PA Output Power vs. Setting

05351-013

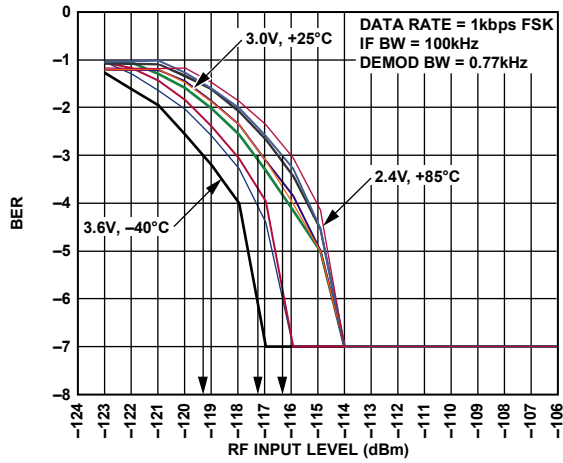

Figure 16. BER vs. VDD and Temperature

05351-016

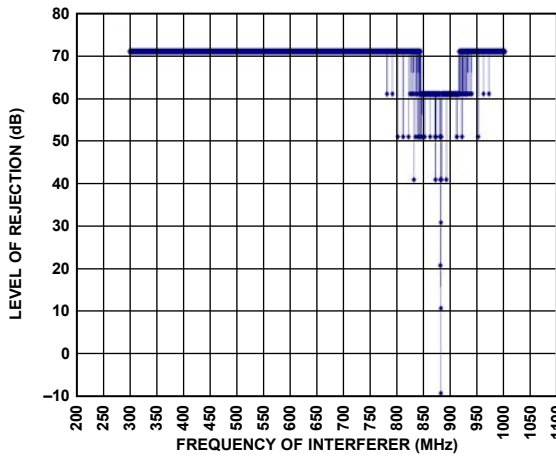

Figure 14. Wideband Interference Rejection; Wanted Signal (880 MHz) at 3 dB above Sensitivity Point Interferer = FM Jammer (9.76 kbps, 10 kHz Deviation)

05351-014

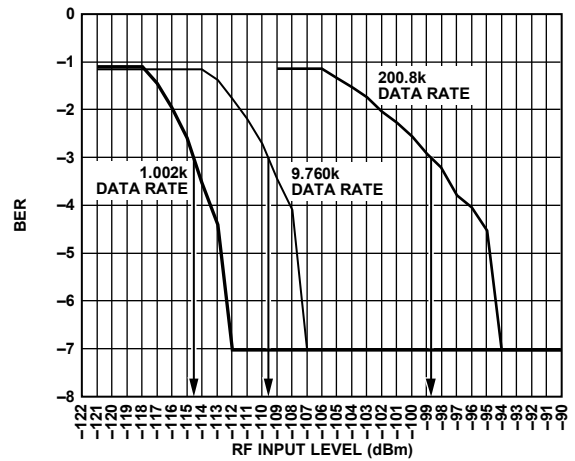

Figure 17. BER vs. Data Rate (Combined Matching Network) Separate LNA and PA Matching Paths Typically Improve Performance by 2 dB

05351-017

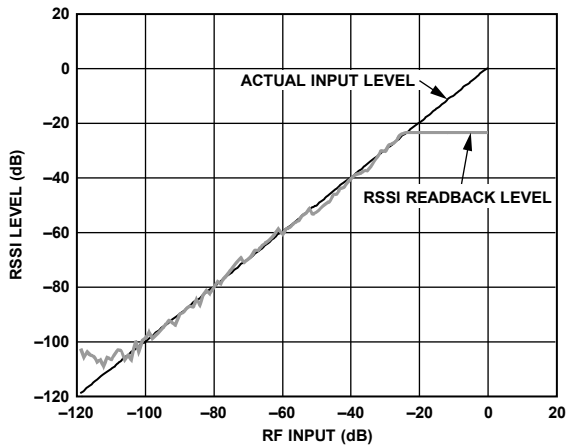

Figure 15. Digital RSSI Readback Linearity

05351-015

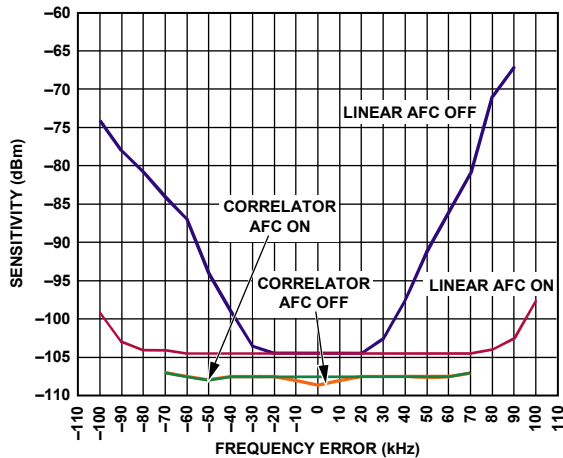

Figure 18. Sensitivity vs. Frequency Error with AFC On/Off

05351-018

# FREQUENCY SYNTHESIZER

## REFERENCE INPUT

The on-board crystal oscillator circuitry (see Figure 19) can use an inexpensive quartz crystal as the PLL reference. The oscillator circuit is enabled by setting R1\_DB12 high. It is enabled by default on power-up and is disabled by bringing CE low. Errors in the crystal can be corrected using the automatic frequency control (see the AFC section) feature or by adjusting the fractional-N value (see the N Counter section). A single-ended reference (TCXO, CXO) can also be used. The CMOS levels should be applied to OSC2 with R1\_DB12 set low.

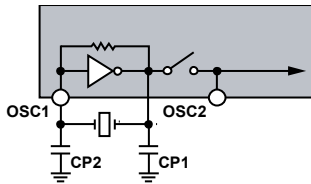

Figure 19. Oscillator Circuit on the ADF7020

Two parallel resonant capacitors are required for oscillation at the correct frequency; their values are dependent on the crystal specification. They should be chosen so that the series value of capacitance added to the PCB track capacitance adds up to the load capacitance of the crystal, usually 20 pF. PCB track capacitance values might vary from 2 pF to 5 pF, depending on board layout. Thus, calculate CP1 and CP2 using:

$$C_L = \frac{1}{\frac{1}{C_{P1}} + \frac{1}{C_{P2}}} + C_{PCB}$$

Where possible, choose capacitors that have a low temperature coefficient to ensure stable frequency operation over all conditions.

## CLKOUT Divider and Buffer

The CLKOUT circuit takes the reference clock signal from the oscillator section, shown in Figure 20, and supplies a divided down 50:50 mark-space signal to the CLKOUT pin. An even divide from 2 to 30 is available. This divide number is set in R1\_DB[8:11]. On power-up, the CLKOUT defaults to divide-by-8.

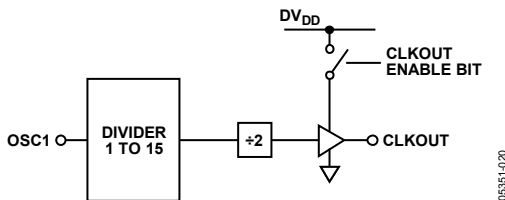

Figure 20. CLKOUT Stage

To disable CLKOUT, set the divide number to 0. The output buffer can drive up to a 20 pF load with a 10% rise time at 4.8 MHz. Faster edges can result in some spurious feedthrough to the output. A small series resistor (50 Ω) can be used to slow the clock edges to reduce these spurs at f<sub>CLK</sub>.

## R Counter

The 3-bit R counter divides the reference input frequency by an integer ranging from 1 to 7. The divided-down signal is presented as the reference clock to the phase frequency detector (PFD). The divide ratio is set in Register 1. Maximizing the PFD frequency reduces the N value. Every doubling of the PFD gives a 3 dB benefit in phase noise, as well as reducing occurrences of spurious components. The R register defaults to R = 1 on power-up.

$$PFD [Hz] = XTAL/R$$

## MUXOUT and Lock Detect

The MUXOUT pin allows the user to access various digital points in the ADF7020. The state of MUXOUT is controlled by Bits R0\_DB[29:31].

## Regulator Ready

Regulator ready is the default setting on MUXOUT after the transceiver has been powered up. The power-up time of the regulator is typically 50 μs. Because the serial interface is powered from the regulator, the regulator must be at its nominal voltage before the ADF7020 can be programmed. The status of the regulator can be monitored at MUXOUT. When the regulator ready signal on MUXOUT is high, programming of the ADF7020 can begin.

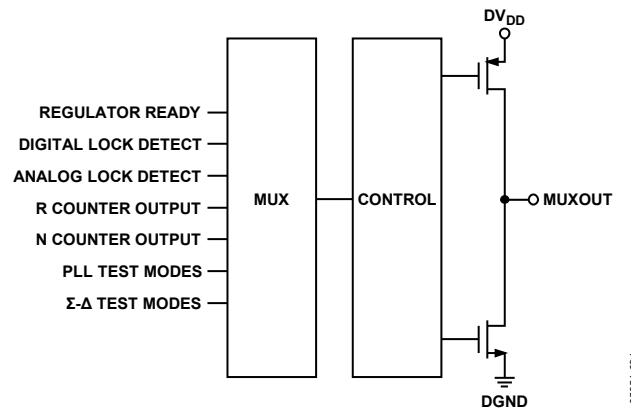

Figure 21. MUXOUT Circuit

## Digital Lock Detect

Digital lock detect is active high. The lock detect circuit is located at the PFD. When the phase error on five consecutive cycles is less than 15 ns, lock detect is set high. Lock detect remains high until 25 ns phase error is detected at the PFD. Because no external components are needed for digital lock detect, it is more widely used than analog lock detect.

## Analog Lock Detect

This N-channel open-drain lock detect should be operated with an external pull-up resistor of 10 kΩ nominal. When a lock has been detected, this output is high with narrow low going pulses.

**Voltage Regulators**

The ADF7020 contains four regulators to supply stable voltages to the part. The nominal regulator voltage is 2.3 V. Each regulator should have a 100 nF capacitor connected between CREGx and GND. When CE is high, the regulators and other associated circuitry are powered on, drawing a total supply current of 2 mA. Bringing the chip-enable pin low disables the regulators, reduces the supply current to less than 1 μA, and erases all values held in the registers. The serial interface operates off a regulator supply; therefore, to write to the part, the user must have CE high and the regulator voltage must be stabilized. Regulator status (CREG4) can be monitored using the regulator ready signal from MUXOUT.

**Loop Filter**

The loop filter integrates the current pulses from the charge pump to form a voltage that tunes the output of the VCO to the desired frequency. It also attenuates spurious levels generated by the PLL. A typical loop filter design is shown in Figure 22.

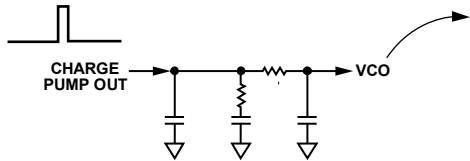

Figure 22. Typical Loop Filter Configuration

In FSK, the loop should be designed so that the loop bandwidth (LBW) is approximately one and a half times the data rate. Widening the LBW excessively reduces the time spent jumping between frequencies, but it can cause insufficient spurious attenuation.

For ASK systems, a wider LBW is recommended. The sudden large transition between two power levels can result in VCO pulling and can cause a wider output spectrum than is desired. By widening the LBW to more than 10 times the data rate, the amount of VCO pulling is reduced, because the loop settles quickly back to the correct frequency. The wider LBW can restrict the output power and data rate of ASK-based systems compared with FSK-based systems.

Narrow-loop bandwidths can result in the loop taking long periods of time to attain lock. Careful design of the loop filter is critical to obtaining accurate FSK/GFSK modulation.

For GFSK, it is recommended that an LBW of 1.0 to 1.5 times the data rate be used to ensure that sufficient samples are taken of the input data while filtering system noise. The free design tool ADIsimSRD Design Studio™ can be used to design loop filters for the ADF7020. It can also be used to view the effect of loop filter bandwidth on the spectrum of the transmitted signal for different combinations of modulation type, data rates, and modulation indices.

**N Counter**

The feedback divider in the ADF7020 PLL consists of an 8-bit integer counter and a 15-bit Σ-Δ fractional-N divider. The integer counter is the standard pulse-swallow type common in PLLs. This sets the minimum integer divide value to 31. The fractional divide value gives very fine resolution at the output, where the output frequency of the PLL is calculated as

$$f_{OUT} = PFD \times \left( INTEGER\_N + \frac{FRACTIONAL\_N}{2^{15}} \right)$$

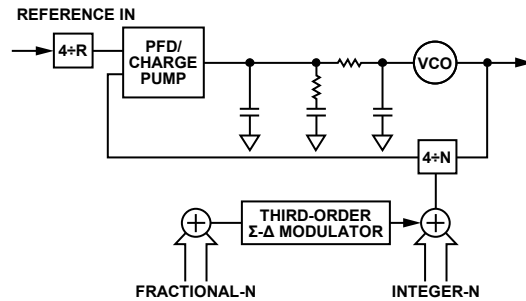

Figure 23. Fractional-N PLL

The maximum N divide value is the combination of the INTEGER\_N (maximum = 255) and the FRACTIONAL\_N (maximum = 32767/32768) and puts a lower limit on the minimum usable PFD.

$$PFD_{MIN} [Hz] = \text{Maximum Required Output Frequency} / (255 + 1)$$

For example, when operating in the European 868 MHz to 870 MHz band, PFD<sub>MIN</sub> equals 3.4 MHz. In the majority of cases, it is advisable to use as high a value of PFD as possible to obtain best phase noise performance.

**Voltage Controlled Oscillator (VCO)**

To minimize spurious emissions, the on-chip VCO operates from 1724 MHz to 1912 MHz. The VCO signal is then divided by 2 to give the required frequency for the transmitter and the required LO frequency for the receiver.

The VCO should be recentered, depending on the required frequency of operation, by programming the VCO Adjust Bits R1\_DB[20:21].

The VCO is enabled as part of the PLL by the PLL Enable bit, R0\_DB28.

A further frequency divide-by-2 block is included to allow operation in the lower 433 MHz and 460 MHz bands. To enable operation in these bands, R1\_DB13 should be set to 1. The VCO needs an external 22 nF between the VCO and the regulator to reduce internal noise.

**VCO Bias Current**

VCO bias current can be adjusted using Bit R1\_DB19 to Bit R1\_DB16. To ensure VCO oscillation, the minimum bias current setting under all conditions is 0xA.

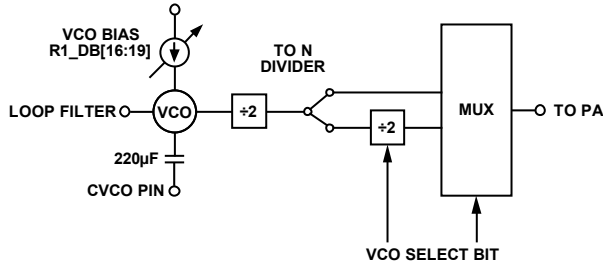

Figure 24. Voltage-Controlled Oscillator (VCO)

06351-024

**CHOOSING CHANNELS FOR BEST SYSTEM PERFORMANCE**

The fractional-N PLL allows the selection of any channel within 868 MHz to 956 MHz (and 433 MHz using divide-by-2) to a resolution of <300 Hz. This also facilitates frequency-hopping systems.

Careful selection of the XTAL frequency is important to achieve best spurious and blocking performance. The architecture of fractional-N causes some level of the nearest integer channel to couple directly to the RF output. This phenomenon is often referred to as integer boundary spurious. If the desired RF channel and the nearest integer channel are separated by a frequency of less than the PLL loop bandwidth (LBW), the integer boundary spurs are not attenuated by the loop.

Integer boundary spurs can be significantly reduced in amplitude by choosing XTAL values that place the wanted RF channel away from integer multiples of the PFD.

# TRANSMITTER

## RF OUTPUT STAGE

The PA of the ADF7020 is based on a single-ended, controlled current, open-drain amplifier that has been designed to deliver up to 13 dBm into a 50 Ω load at a maximum frequency of 956 MHz.

The PA output current and, consequently, the output power are programmable over a wide range. The PA configurations in FSK/GFSK and ASK/OOK modulation modes are shown in Figure 25 and Figure 26, respectively. In FSK/GFSK modulation mode, the output power is independent of the state of the DATA I/O pin. In ASK/OOK modulation mode, it is dependent on the state of the DATA I/O pin and Bit R2\_DB29, which selects the polarity of the TxData input. For each transmission mode, the output power can be adjusted as follows:

- FSK/GFSK  
The output power is set using Bits R2\_DB[9:14].
- ASK  
The output power for the inactive state of the TxData input is set by Bits R2\_DB[15:20]. The output power for the active state of the TxData input is set by Bits R2\_DB[9:14].
- OOK  
The output power for the active state of the TxData input is set by Bits R2\_DB[9:14]. The PA is muted when the TxData input is inactive.

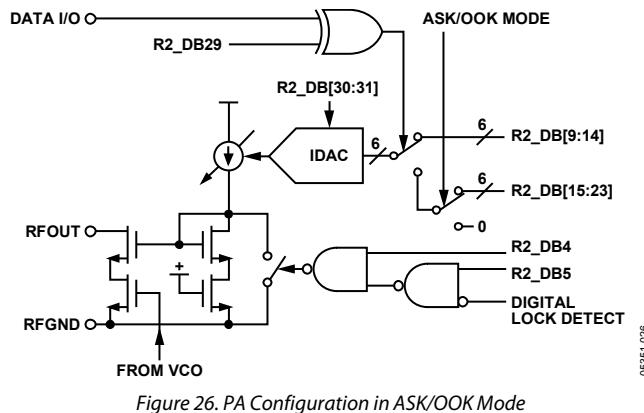
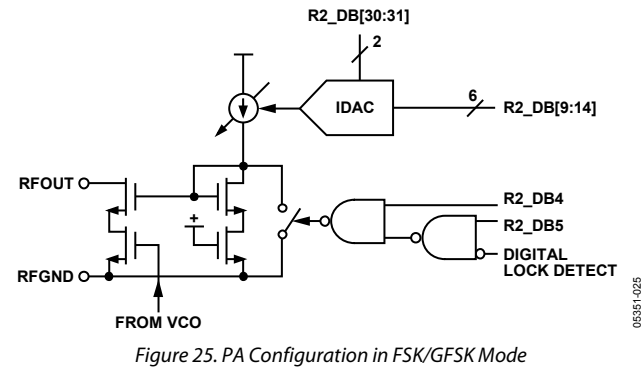

The PA is equipped with overvoltage protection, which makes it robust in severe mismatch conditions. Depending on the application, one can design a matching network for the PA to exhibit optimum efficiency at the desired radiated output power level for a wide range of different antennas, such as loop or monopole antennas. See the LNA/PA Matching section for details.

### PA Bias Currents

Control Bits R2\_DB[30:31] facilitate an adjustment of the PA bias current to further extend the output power control range, if necessary. If this feature is not required, the default value of 7 μA is recommended. The output stage is powered down by resetting Bit R2\_DB4. To reduce the level of undesired spurious emissions, the PA can be muted during the PLL lock phase by toggling this bit.

## MODULATION SCHEMES

### Frequency Shift Keying (FSK)

Frequency shift keying is implemented by setting the N value for the center frequency and then toggling this with the TxData line. The deviation from the center frequency is set using Bits R2\_DB[15:23]. The deviation from the center frequency in Hz is

$$FSK_{DEVIATION} [Hz] = \frac{PFD \times Modulation\ Number}{2^{14}}$$

where *Modulation Number* is a number from 1 to 511 (R2\_DB[15:23]).

Select FSK using Bits R2\_DB[6:8].

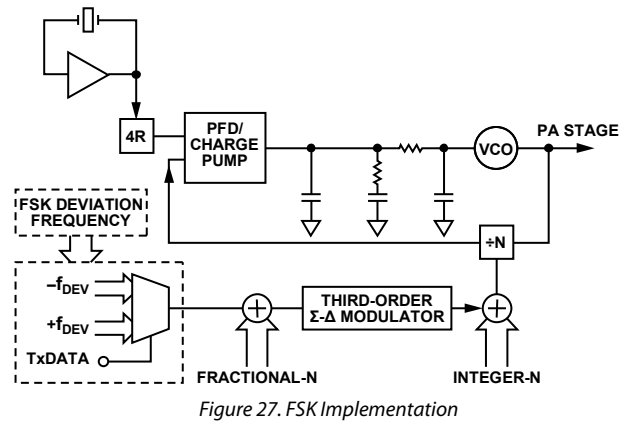

**Gaussian Frequency Shift Keying (GFSK)**

Gaussian frequency shift keying reduces the bandwidth occupied by the transmitted spectrum by digitally prefiltering the TxData. A TxCLK output line is provided from the ADF7020 for synchronization of TxData from the microcontroller. The TxCLK line can be connected to the clock input of a shift register that clocks data to the transmitter at the exact data rate.

**Setting Up the ADF7020 for GFSK**

To set up the frequency deviation, set the PFD and the modulation control bits.

$$GFSK_{DEVIATION}[\text{Hz}] = \frac{PFD \times 2^m}{2^{12}}$$

where  $m$  is GFSK\_MOD\_CONTROL, set using R2\_DB[24:26].

To set up the GFSK data rate,

$$DR[\text{bps}] = \frac{PFD}{DIVIDER\_FACTOR \times INDEX\_COUNTER}$$

The INDEX\_COUNTER variable controls the number of intermediate frequency steps between the low and high frequency. It is usually possible to achieve a given data rate with various combinations of DIVIDER\_FACTOR and INDEX\_COUNTER. Choosing a higher INDEX\_COUNTER can help in improving the spectral performance.

**Amplitude Shift Keying (ASK)**

Amplitude shift keying is implemented by switching the output stage between two discrete power levels. This is accomplished by toggling the DAC, which controls the output level between two 6-bit values set up in Register 2. A 0 TxData bit sends Bits R2\_DB[15:20] to the DAC. A high TxData bit sends Bits R2\_DB[9:14] to the DAC. A maximum modulation depth of 30 dB is possible.

**On-Off Keying (OOK)**

On-off keying is implemented by switching the output stage to a certain power level for a high TxData bit and switching the output stage off for a zero. For OOK, the transmitted power for a high input is programmed using Bits R2\_DB[9:14].

**Gaussian On-Off Keying (GOOK)**

Gaussian on-off keying represents a prefiltered form of OOK modulation. The usually sharp symbol transitions are replaced with smooth Gaussian filtered transitions, the result being a reduction in frequency pulling of the VCO. Frequency pulling of the VCO in OOK mode can lead to a wider than desired BW, especially if it is not possible to increase the loop filter BW > 300 kHz. The GOOK sampling clock samples data at the data rate (see the Setting Up the ADF7020 for GFSK section).

# RECEIVER

## RF FRONT END

The ADF7020 is based on a fully integrated, low IF receiver architecture. The low IF architecture facilitates a very low external component count and does not suffer from power line-induced interference problems.

Figure 28 shows the structure of the receiver front end. The many programming options allow users to trade off sensitivity, linearity, and current consumption against each other in the way best suitable for their applications. To achieve a high level of resilience against spurious reception, the LNA features a differential input. Switch SW2 shorts the LNA input when transmit mode is selected (R0\_DB27 = 0). This feature facilitates the design of a combined LNA/PA matching network, avoiding the need for an external Rx/Tx switch. See the LNA/PA Matching section for details on the design of the matching network.

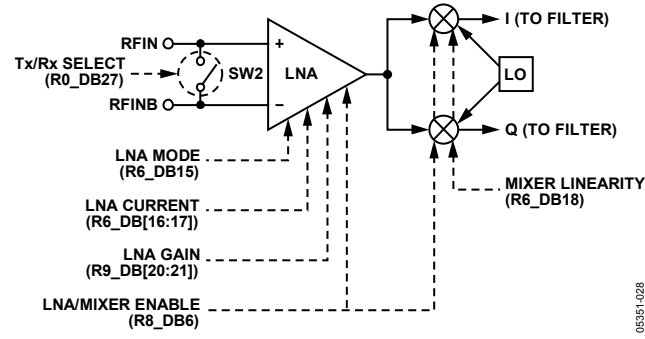

Figure 28. ADF7020 RF Front End

The LNA is followed by a quadrature down conversion mixer, that converts the RF signal to the IF frequency of 200 kHz. It is important to consider that the output frequency of the synthesizer must be programmed to a value 200 kHz below the center frequency of the received channel.

The LNA has two basic operating modes: high gain/low noise mode and low gain/low power mode. To switch between these two modes, use the LNA\_MODE bit, R6\_DB15. The mixer is also configurable between a low current and an enhanced linearity mode using the MIXER\_LINEARITY bit, R6\_DB18.

Based on the specific sensitivity and linearity requirements of the application, it is recommended to adjust control bits LNA\_MODE (R6\_DB15) and MIXER\_LINEARITY (R6\_DB18), as outlined in Table 5.

The gain of the LNA is configured by the LNA\_GAIN field, R9\_DB[20:21], and can be set by either the user or the automatic gain control (AGC) logic.

### IF Filter Settings/Calibration

Out-of-band interference is rejected by means of a fourth-order Butterworth polyphase IF filter centered around a frequency of 200 kHz. The bandwidth of the IF filter can be programmed between 100 kHz and 200 kHz by using Control Bits R1\_DB[22:23] and should be chosen as a compromise between interference rejection, attenuation of the desired signal, and the AFC pull-in range.

To compensate for manufacturing tolerances, the IF filter should be calibrated once after power-up. The IF filter calibration logic requires that the IF filter divider in Bits R6\_DB[20:28] be set as dependent on the crystal frequency. Once initiated by setting Bit R6\_DB19, the calibration is performed automatically without any user intervention. The calibration time is 200 μs, during which the ADF7020 should not be accessed. It is important not to initiate the calibration cycle before the crystal oscillator has fully settled. If the AGC loop is disabled, the gain of IF filter can be set to three levels using the FILTER\_GAIN field, R9\_DB[20:21]. The filter gain is adjusted automatically, if the AGC loop is enabled.

Table 5. LNA/Mixer Modes

Receiver Mode	LNA Mode (R6_DB15)	LNA Gain Value (R9_DB[20:21])	Mixer Linearity (R6_DB18)	Sensitivity (DR = 9.6 kbps, f <sub>DEV</sub> = 10 kHz)	Rx Current Consumption (mA)	Input IP3 (dBm)
High Sensitivity Mode (Default)	0	30	0	-110.5	21	-24
RxMode2	1	10	0	-104	20	-13.5
Low Current Mode	1	3	0	-94	19	-5
Enhanced Linearity Mode	1	3	1	-88	19	-3
RxMode5	1	10	1	-98	20	-10
RxMode6	0	30	1	-107	21	-20

**RSSI/AGC**

The RSSI is implemented as a successive compression log amp following the baseband channel filtering. The log amp achieves ±3 dB log linearity. It also doubles as a limiter to convert the signal-to-digital levels for the FSK demodulator. The RSSI itself is used for amplitude shift keying (ASK) demodulation. In ASK mode, extra digital filtering is performed on the RSSI value. Offset correction is achieved using a switched capacitor integrator in feedback around the log amp. This uses the baseband offset clock divide. The RSSI level is converted for user readback and digitally controlled AGC by an 80-level (7-bit) flash ADC. This level can be converted to input power in dBm.

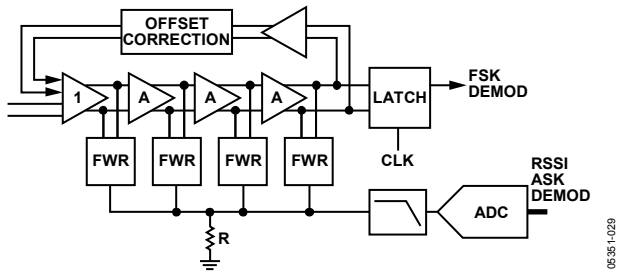

NOTES  
1. FWR = FULL WAVE RECTIFIER

Figure 29. RSSI Block Diagram

**RSSI Thresholds**

When the RSSI is above AGC\_HIGH\_THRESHOLD, the gain is reduced. When the RSSI is below AGC\_LOW\_THRESHOLD, the gain is increased. A delay (AGC\_DELAY) is programmed to allow for settling of the loop. The user programs the two threshold values (recommended defaults of 30 and 70) and the delay (default of 10). The default AGC setup values should be adequate for most applications. The threshold values must be chosen to be more than 30 apart for the AGC to operate correctly.

**Offset Correction Clock**

In Register 3, the user should set the BB offset clock divide bits R3\_DB[4:5] to give an offset clock between 1 MHz and 2 MHz.

$$BBOS\_CLK\ (Hz) = XTAL / (BBOS\_CLK\_DIVIDE)$$

where BBOS\_CLK\_DIVIDE can be set to 4, 8, or 16.

**AGC Information and Timing**

AGC is selected by default, and operates by selecting the appropriate LNA and filter gain settings for the measured RSSI level. It is possible to disable AGC by writing to Register 9 if entering one of the modes listed in Table 5 is desired, for example. The time for the AGC circuit to settle and, therefore, the time to take an accurate RSSI measurement is typically 150 μs, although this depends on how many gain settings the AGC circuit has to cycle through. After each gain change, the AGC loop waits for a programmed time to allow transients to settle.

This wait time can be adjusted to speed up this settling by adjusting the appropriate parameters.

$$AGC\_WAIT\_TIME = \frac{AGC\_DELAY \times SEQ\_CLK}{XTAL}$$

$$AGC\ Settling = AGC\_WAIT\_TIME \times Number\ of\ Gain\ Changes$$

Thus, in the worst case, if the AGC loop has to go through all 5 gain changes, AGC\_DELAY = 10, SEQ\_CLK = 200 kHz, AGC Settling = 10 × 5 μs × 5 = 250 μs. Minimum AGC\_WAIT\_TIME needs to be at least 25 μs.

**RSSI Formula (Converting to dBm)**

$$INPUT\_POWER\ [dBm] = -120\ dBm + (READBACK\_CODE + GAIN\_MODE\_CORRECTION) \times 0.5$$

where:

READBACK\_CODE is given by Bit RV7 to Bit RV1 in the readback register (see the Readback Format section). GAIN\_MODE\_CORRECTION is given by the values in Table 6.

LNA gain and filter gain (LG2/LG1, FG2/FG1) are also obtained from the readback register.

Table 6. Gain Mode Correction

LNA Gain (LG2, LG1)	Filter Gain (FG2, FG1)	Gain Mode Correction
H (1,1)	H (1,0)	0
M (1,0)	H (1,0)	24
M (1,0)	M (0,1)	45
M (1,0)	L (0,0)	63
L (0,1)	L (0,0)	90
EL (0,0)	L (0,0)	105

An additional factor should be introduced to account for losses in the front-end matching network/antenna.

**FSK DEMODULATORS ON THE ADF7020**

The two FSK demodulators on the ADF7020 are

- FSK correlator/demodulator
- Linear demodulator

Select these using the demodulator select bits, R4\_DB[4:5].

**FSK CORRELATOR/DEMODULATOR**

The quadrature outputs of the IF filter are first limited and then fed to a pair of digital frequency correlators that perform band-pass filtering of the binary FSK frequencies at (IF + f<sub>DEV</sub>) and (IF - f<sub>DEV</sub>). Data is recovered by comparing the output levels from each of the two correlators. The performance of this frequency discriminator approximates that of a matched filter detector, which is known to provide optimum detection in the presence of additive white Gaussian noise (AWGN).

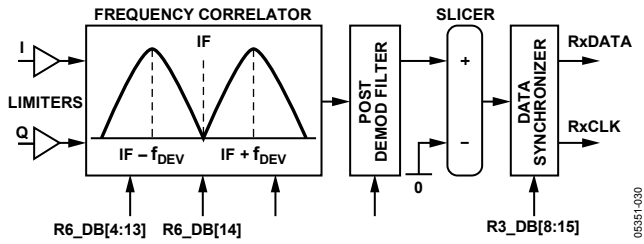

Figure 30. FSK Correlator/Demodulator Block Diagram

**Postdemodulator Filter**

A second-order, digital low-pass filter removes excess noise from the demodulated bit stream at the output of the discriminator. The bandwidth of this postdemodulator filter is programmable and must be optimized for the user’s data rate. If the bandwidth is set too narrow, performance is degraded due to intersymbol interference (ISI). If the bandwidth is set too wide, excess noise degrades the receiver’s performance. Typically, the 3 dB bandwidth of this filter is set at approximately 0.75 times the user’s data rate, using Bits R4\_DB[6:15].

**Bit Slicer**

The received data is recovered by the threshold detecting the output of the postdemodulator low-pass filter. In the correlator/demodulator, the binary output signal levels of the frequency discriminator are always centered on 0. Therefore, the slicer threshold level can be fixed at 0, and the demodulator performance is independent of the run-length constraints of the transmit data bit stream. This results in robust data recovery, which does not suffer from the classic baseline wander problems that exist in the more traditional FSK demodulators.

Frequency errors are removed by an internal AFC loop that measures the average IF frequency at the limiter output and applies a frequency correction value to the fractional-N synthesizer. This loop should be activated when the frequency errors are greater than approximately 40% of the transmit frequency deviation (see the AFC section).

**Data Synchronizer**

An oversampled digital PLL is used to resynchronize the received bit stream to a local clock. The oversampled clock rate of the PLL (CDR\_CLK) must be set at 32 times the data rate. See the Register 3—Receiver Clock Register Comments section for a definition of how to program. The clock recovery PLL can accommodate frequency errors of up to ±2%.

**FSK Correlator Register Settings**

To enable the FSK correlator/demodulator, Bits R4\_DB[5:4] should be set to 01. To achieve best performance, the bandwidth of the FSK correlator must be optimized for the specific deviation frequency that is used by the FSK transmitter.

The discriminator BW is controlled in Register 6 by Bit R6\_DB[4:13] and is defined as

$$DISCRIMINATOR\_BW = \frac{DEMOD\_CLK \times K}{800 \times 10^3}$$

where:

DEMOD\_CLK is as defined in the Register 3—Receiver Clock Register section, second comment.

$K = Round(200 \times 10^3 / FSK\ Deviation)$

To optimize the coefficients of the FSK correlator, two additional bits, R6\_DB14 and R6\_DB29, must be assigned. The value of these bits depends on whether K (as defined above) is odd or even. These bits are assigned according to Table 7 and Table 8.

**Table 7. When K Is Even**

K	K/2	R6_DB14	R6_DB29
Even	Even	0	0
Even	Odd	0	1

**Table 8. When K Is Odd**

K	(K + 1)/2	R6_DB14	R6_DB29
Odd	Even	1	0
Odd	Odd	1	1

**Postdemodulator Bandwidth Register Settings**

The 3 dB bandwidth of the postdemodulator filter is controlled by Bits R4\_DB[6:15] and is given by

$$POSTDEMOD\_BW\_SETTING = \frac{2^{10} \times 2\pi \times f_{CUTOFF}}{DEMOD\_CLK}$$

where  $f_{CUTOFF}$  is the target 3 dB bandwidth in Hz of the post-demodulator filter. This should typically be set to 0.75 times the data rate (DR).

Some sample settings for the FSK correlator/demodulator are

$$\begin{aligned} DEMOD\_CLK &= 5 \text{ MHz} \\ DR &= 9.6 \text{ kbps} \\ f_{DEV} &= 20 \text{ kHz} \end{aligned}$$

Therefore,

$$\begin{aligned} f_{CUTOFF} &= 0.75 \times 9.6 \times 10^3 \text{ Hz} \\ POSTDEMOD\_BW\_SETTING &= 2^{11} \pi 7.2 \times 10^3 \text{ Hz} / (5 \text{ MHz}) \\ POSTDEMOD\_BW\_SETTING &= Round(9.26) = 9 \end{aligned}$$

and

$$\begin{aligned} K &= Round(200 \text{ kHz}) / 20 \text{ kHz} = 10 \\ DISCRIMINATOR\_BW &= (5 \text{ MHz} \times 10) / (800 \times 10^3) = 62.5 = 63 \text{ (rounded to the nearest integer)} \end{aligned}$$

Table 9. Register Settings<sup>1</sup>

Setting Name	Register Address	Value
POSTDEMOD_BW_SETTING	R4_DB[6:15]	0x09
DISCRIMINATOR_BW	R6_DB[4:13]	0x3F
DOT_PRODUCT	R6_DB14	0
RXDATA_INVERT	R6_DB29	1

<sup>1</sup> The latest version of the [ADF7020](#) configuration software can aid in calculating register settings.

## LINEAR FSK DEMODULATOR

Figure 31 shows a block diagram of the linear FSK demodulator.

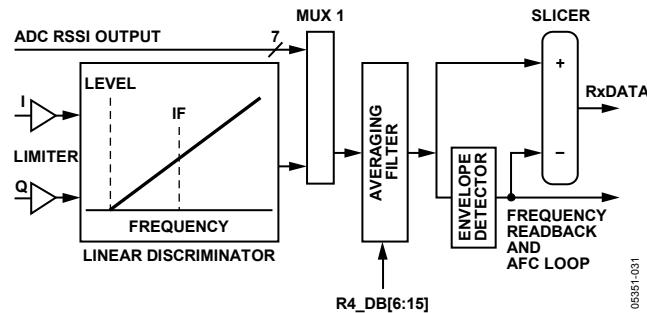

Figure 31. Block Diagram of Frequency Measurement System and ASK/OOK/Linear FSK Demodulator

This method of frequency demodulation is useful when very short preamble length is required, and the system protocol cannot support the overhead of the settling time of the internal feedback AFC loop settling.

A digital frequency discriminator provides an output signal that is linearly proportional to the frequency of the limiter outputs. The discriminator output is then filtered and averaged using a combined averaging filter and envelope detector. The demodulated FSK data is recovered by threshold-detecting the output of the averaging filter, (see Figure 31). In this mode, the slicer output shown in Figure 31 is routed to the data synchronizer PLL for clock synchronization. To enable the linear FSK demodulator, set Bits R4\_DB[4:5] to 00.

The 3 dB bandwidth of the postdemodulation filter is set in the same way as the FSK correlator/demodulator, which is set in R4\_DB[6:15] and is defined as

$$POSTDEMOD\_BW\_SETTING = \frac{2^{10} \times 2\pi \times f_{CUTOFF}}{DEMOM\_CLK}$$

where  $f_{CUTOFF}$  is the target 3 dB bandwidth in Hz of the postdemodulator filter. DEMOD\_CLK is as defined in the Register 3—Receiver Clock Register section, second comment.

## ASK/OOK Operation

ASK/OOK demodulation is activated by setting Bits R4\_DB[4:5] to 10.

Digital filtering and envelope detecting the digitized RSSI input via MUX 1, as shown in Figure 31, performs ASK/OOK demodulation. The bandwidth of the digital filter must be optimized to remove any excess noise without causing ISI in the received ASK/OOK signal.

The 3 dB bandwidth of this filter is typically set at approximately 0.75 times the user data rate and is assigned by R4\_DB[6:15] as

$$POSTDEMOD\_BW\_SETTING = \frac{2^{10} \times 2\pi \times f_{CUTOFF}}{DEMOM\_CLK}$$

where  $f_{CUTOFF}$  is the target 3 dB bandwidth in Hz of the postdemodulator filter.

It is also recommended to adjust the peak response factor to 6 in Register 10 for robust operation over the full input range. This improves the receiver's AM immunity performance.

## AFC

The [ADF7020](#) supports a real-time AFC loop, which is used to remove frequency errors that can arise due to mismatches between the transmit and receive crystals. This uses the frequency discriminator block, as described in the Linear FSK Demodulator section (see Figure 31). The discriminator output is filtered and averaged to remove the FSK frequency modulation, using a combined averaging filter and envelope detector. In FSK mode, the output of the envelope detector provides an estimate of the average IF frequency.

Two methods of AFC, external and internal, are supported on the [ADF7020](#) (in FSK mode only).

### External AFC

The user reads back the frequency information through the [ADF7020](#) serial port and applies a frequency correction value to the fractional-N synthesizer's N divider.

The frequency information is obtained by reading the 16-bit signed AFC\_READBACK, as described in the Readback Format section, and applying the following formula:

$$FREQ\_RB \text{ [Hz]} = (AFC\_READBACK \times DEMOM\_CLK)/2^{15}$$

Note that while the AFC\_READBACK value is a signed number, under normal operating conditions, it is positive. The frequency error can be calculated from

$$FREQ\_ERROR \text{ [Hz]} = FREQ\_RB \text{ (Hz)} - 200 \text{ kHz}$$

Thus, in the absence of frequency errors, the FREQ\_RB value is equal to the IF frequency of 200 kHz.

**Internal AFC**

The ADF7020 supports a real-time internal automatic frequency control loop. In this mode, an internal control loop automatically monitors the frequency error and adjusts the synthesizer N divider using an internal PI control loop.

The internal AFC control loop parameters are controlled in Register 11. The internal AFC loop is activated by setting R11\_DB20 to 1. A scaling coefficient must also be entered, based on the crystal frequency in use. This is set up in Bits R11\_DB[4:19] and should be calculated using

$$AFC\_SCALING\_COEFFICIENT = (500 \times 2^{24})/XTAL$$

Therefore, using a 10 MHz XTAL yields an AFC scaling coefficient of 839.

**AFC Performance**

The improved sensitivity performance of the Rx when AFC is enabled and in the presence of frequency errors is shown in Figure 18. The maximum AFC frequency range is  $\pm 50$  kHz, which corresponds to  $\pm 58$  ppm at 868 MHz. This is the total error tolerance allowed in the link. For example, in a point-to-point system, AFC can compensate for two  $\pm 29$  ppm crystals or one  $\pm 50$  ppm crystal and one  $\pm 8$  ppm TCXO.

AFC settling typically takes 48 bits to settle within  $\pm 1$  kHz. This can be improved by increasing the postdemodulator bandwidth in Register 4 at the expense of Rx sensitivity.

When AFC errors have been removed using either the internal or external AFC, further improvement in the receiver's sensitivity can be obtained by reducing the IF filter bandwidth using Bits R1\_DB[22:23].

**AUTOMATIC SYNC WORD RECOGNITION**

The ADF7020 also supports automatic detection of the sync or ID fields. To activate this mode, the sync (or ID) word must be preprogrammed into the ADF7020. In receive mode, this preprogrammed word is compared to the received bit stream and, when a valid match is identified, the external pin INT/LOCK is asserted by the ADF7020.

This feature can be used to alert the microprocessor that a valid channel has been detected. It relaxes the computational requirements of the microprocessor and reduces the overall power consumption. The INT/LOCK is automatically deasserted again after nine data clock cycles.

The automatic sync/ID word detection feature is enabled by selecting Demodulator Mode 2 or Demodulator Mode 3 in the demodulator setup register. Do this by setting Bits R4\_DB[25:23] = 010 or 011. Bits R5\_DB[4:5] are used to set the length of the sync/ID word, which can be 12, 16, 20, or 24 bits long. The transmitter must transmit the MSB of the sync byte first and the LSB last to ensure proper alignment in the receiver sync byte detection hardware.

For systems using forward error correction (FEC), an error tolerance parameter can also be programmed that accepts a valid match when up to three bits of the word are incorrect. The error tolerance value is assigned in Bits R5\_DB[6:7].

## APPLICATIONS INFORMATION

### LNA/PA MATCHING

The ADF7020 exhibits optimum performance in terms of sensitivity, transmit power, and current consumption only if its RF input and output ports are properly matched to the antenna impedance. For cost-sensitive applications, the ADF7020 is equipped with an internal Rx/Tx switch that facilitates the use of a simple combined passive PA/LNA matching network.

Alternatively, an external Rx/Tx switch, such as the Analog Devices ADG919, can be used. It yields a slightly improved receiver sensitivity and lower transmitter power consumption.

### External Rx/Tx Switch

Figure 32 shows a configuration using an external Rx/Tx switch. This configuration allows an independent optimization of the matching and filter network in the transmit and receive path and is, therefore, more flexible and less difficult to design than the configuration using the internal Rx/Tx switch. The PA is biased through Inductor L1, while C1 blocks dc current. Both elements, L1 and C1, also form the matching network, which transforms the source impedance into the optimum PA load impedance,  $Z_{OPT\_PA}$ .

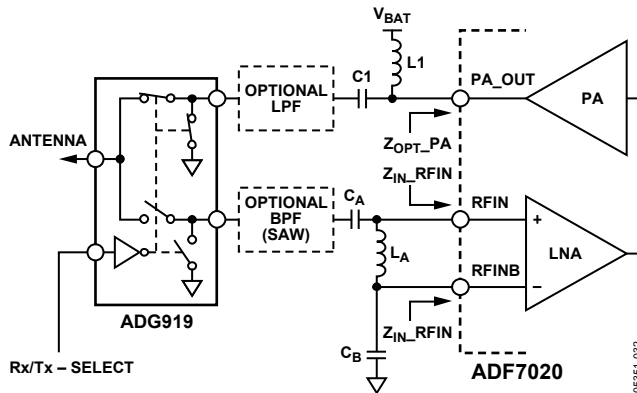

Figure 32. ADF7020 with External Rx/Tx Switch

$Z_{OPT\_PA}$  depends on various factors, such as the required output power, the frequency range, the supply voltage range, and the temperature range. Selecting an appropriate  $Z_{OPT\_PA}$  helps to minimize the Tx current consumption in the application. Application Note AN-767 contains a number of  $Z_{OPT\_PA}$  values for representative conditions. Under certain conditions, however, it is recommended that a suitable  $Z_{OPT\_PA}$  value be obtained by means of a load-pull measurement.

Due to the differential LNA input, the LNA matching network must be designed to provide both a single-ended-to-differential conversion and a complex conjugate impedance match. The network with the lowest component count that can satisfy these requirements is the configuration shown in Figure 32, which consists of two capacitors and one inductor.

A first-order implementation of the matching network can be obtained by understanding the arrangement as two L type matching networks in a back-to-back configuration. Due to the asymmetry of the network with respect to ground, a compromise between the input reflection coefficient and the maximum differential signal swing at the LNA input must be established. The use of appropriate CAD software is strongly recommended for this optimization.

Depending on the antenna configuration, the user may need a harmonic filter at the PA output to satisfy the spurious emission requirement of the applicable government regulations. The harmonic filter can be implemented in various ways, such as a discrete LC pi or T-stage filter. Dielectric low-pass filter components, such as the LFL18924MTC1A052 (for operation in the 915 MHz and 868 MHz band) by Murata Manufacturing, Co., Ltd., represent an attractive alternative to discrete designs. Application Note AN-917 describes how to replace the Murata dielectric filter with an LC filter if desired.

The immunity of the ADF7020 to strong out-of-band interference can be improved by adding a band-pass filter in the Rx path. Apart from discrete designs, SAW or dielectric filter components, such as the SAFCH869MAM0T00 or SAFCH915MAL0N00, both by Murata, are well suited for this purpose. Alternatively, the ADF7020 blocking performance can be improved by selecting the high linearity mode, as described in Table 5.

### Internal Rx/Tx Switch

Figure 33 shows the ADF7020 in a configuration where the internal Rx/Tx switch is used with a combined LNA/PA matching network. This is the configuration used in the EVAL-ADF7020DBZ1 through EVAL-ADF7020DBZ3 evaluation boards. For most applications, the slight performance degradation of 1 dB to 2 dB caused by the internal Rx/Tx switch is acceptable, allowing the user to take advantage of the cost saving potential of this solution. The design of the combined matching network must compensate for the reactance presented by the networks in the Tx and the Rx paths, taking the state of the Rx/Tx switch into consideration.

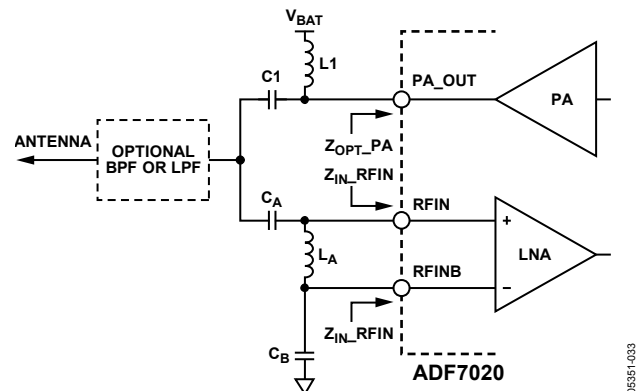

Figure 33. ADF7020 with Internal Rx/Tx Switch

The procedure typically requires several iterations until an acceptable compromise is reached. The successful implementation of a combined LNA/PA matching network for the ADF7020 is critically dependent on the availability of an accurate electrical model for the PC board. In this context, the use of a suitable CAD package is strongly recommended. To avoid this effort, however, a small form-factor reference design for the ADF7020 is provided, including matching and harmonic filter components. Gerber files and schematics are available on the product page at: [www.analog.com/ADF7020](http://www.analog.com/ADF7020).

**IMAGE REJECTION CALIBRATION**

The image channel in the ADF7020 is 400 kHz below the desired signal. The polyphase filter rejects this image with an asymmetric frequency response. The image rejection performance of the receiver is dependent on how well matched the I and Q signals are in amplitude, and how well matched the quadrature is between them (that is, how close to 90° apart they are.) The uncalibrated image rejection performance is approximately 30 dB. However, it is possible to improve this performance by as much as 20 dB by finding the optimum I/Q gain and phase adjust settings.

**Calibration Procedure and Setup**

The image rejection calibration works by connecting an external RF signal to the RF input port. The external RF signal should be set at the image frequency and the filter rejection measured by monitoring the digital RSSI readback. As the image rejection is improved by adjusting the I/Q Gain and phase, the RSSI reading reduces.

The magnitude of the phase adjust is set by using the IR\_PHASE\_ADJUST bits (R10\_DB[24:27]). This correction can be applied to either the I channel or Q channel, by toggling bit (R10\_DB28).

The magnitude of the I/Q gain is adjusted by the IR\_GAIN\_ADJUST bits (R10\_DB[16:20]). This correction can be applied to either the I or Q channel using bit (R10\_DB22), while the GAIN/ATTENUATE bit (R10\_DB21) sets whether the gain adjustment defines a gain or attenuation adjust.

The calibration results are valid over changes in the ADF7020 supply voltage. However, there is some variation with temperature. A typical plot of variation in image rejection over temperature after initial calibrations at +25°C, -40°C, and +85°C is shown in Figure 34. The internal temperature sensor on the ADF7020 can be used to determine if a new IR calibration is required.

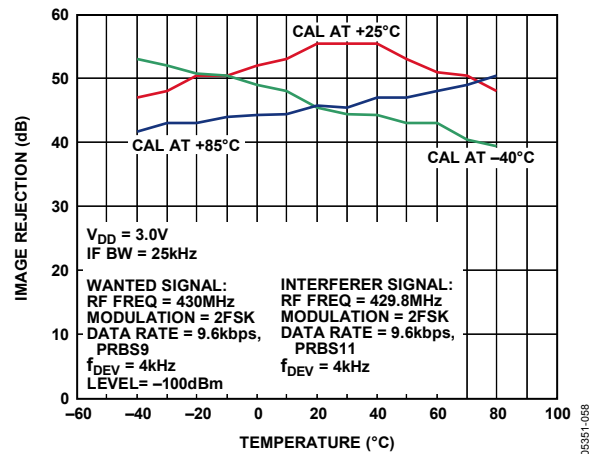

Figure 34. Image Rejection Variation with Temperature after Initial Calibrations at +25°C, -40°C, and +85°C

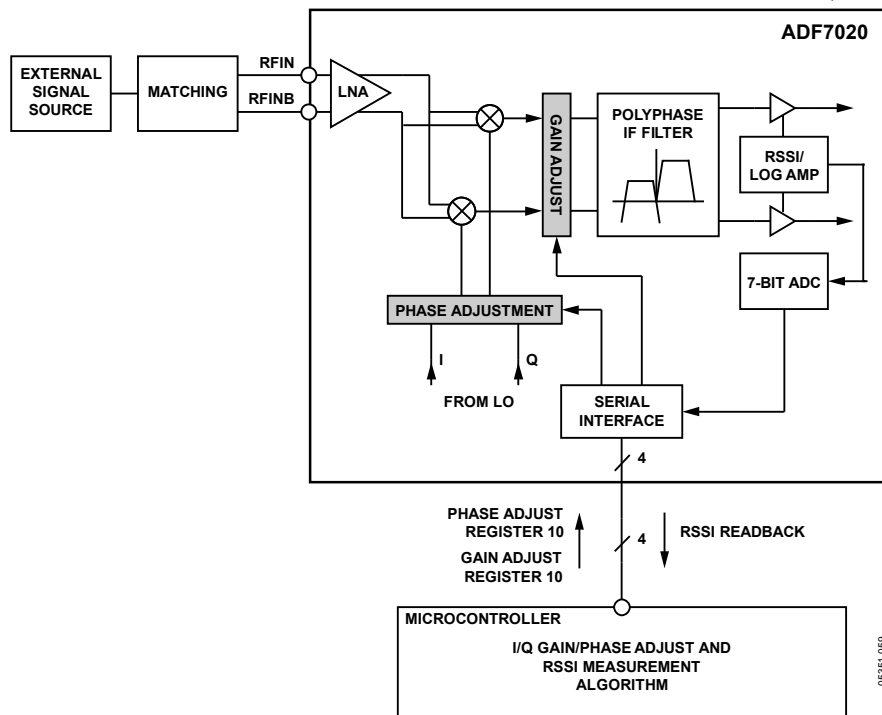

Figure 35. Image Rejection Calibration Using the Internal Calibration Source and a Microcontroller

**TRANSMIT PROTOCOL AND CODING CONSIDERATIONS**

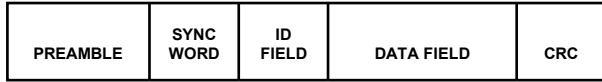

Figure 36. Typical Format of a Transmit Protocol

A dc-free preamble pattern is recommended for FSK/GFSK/ASK/OOK demodulation. The recommended preamble pattern is a dc-balanced pattern such as a 10101010... sequence.

Preamble patterns with longer run-length constraints such as 11001100... can also be used. However, this results in a longer synchronization time of the received bit stream in the receiver.

The remaining fields that follow the preamble header do not have to use dc-free coding. For these fields, the ADF7020 can accommodate coding schemes with a run-length of up to several bytes without any performance degradation, for example several bytes of 0x00 or 0xFF. To help minimize bit errors when receiving these long runs of continuous 0s or 1s, it is important to choose a data rate and XTAL combination that minimizes the error between the actual data rate and the on-board CDR\_CLK/32. For example, if a 9.6 kbps data rate is desired, then using an 11.0592 MHz XTAL gives a 0% nominal error between the desired data rate and CDR\_CLK/32. Application Note AN-915 gives more details on supporting long run lengths on the ADF7020.

The ADF7020 can also support Manchester-encoded data for the entire protocol. Manchester decoding needs to be done on the companion microcontroller, however. In this case, the ADF7020 should be set up at the Manchester chip or baud rate, which is twice the effective data rate.

**DEVICE PROGRAMMING AFTER INITIAL POWER-UP**

Table 10 lists the minimum number of writes needed to set up the ADF7020 in either Tx or Rx mode after CE is brought high. Additional registers can also be written to tailor the part to a particular application, such as setting up sync byte detection or enabling AFC. When going from Tx to Rx or vice versa, the user needs to write only to the N Register to alter the LO by 200 kHz and to toggle the Tx/Rx bit.

Table 10. Minimum Register Writes Required for Tx/Rx Setup

Mode	Register				
Tx	Reg. 0	Reg. 1	Reg. 2		
Rx (OOK)	Reg. 0	Reg. 1	Reg. 3	Reg. 4	Reg. 6
Rx (G/FSK)	Reg. 0	Reg. 1	Reg. 3	Reg. 4	Reg. 6
Tx ↔ Rx	Reg. 0				

Figure 39 and Figure 40 show the recommended programming sequence and associated timing for power-up from standby mode.

**INTERFACING TO MICROCONTROLLER/DSP**

Low level device drivers are available for interfacing the ADF7020 to the Analog Devices ADuC841 analog microcontroller, or the Blackfin® ADSP-BF533 DSP, using the hardware connections shown in Figure 37 and Figure 38.

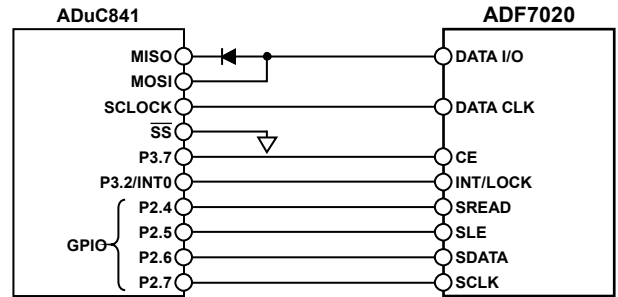

Figure 37. ADuC841 to ADF7020 Connection Diagram

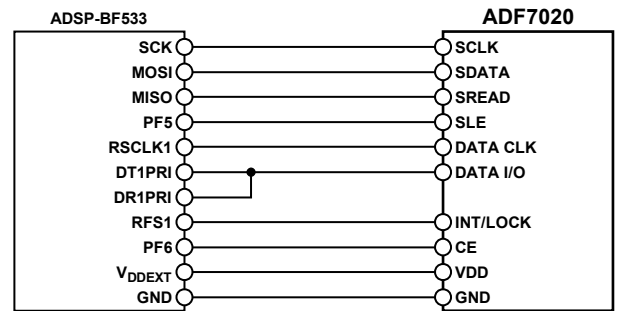

Figure 38. ADSP-BF533 to ADF7020 Connection Diagram

**POWER CONSUMPTION AND BATTERY LIFETIME CALCULATIONS**

Average Power Consumption can be calculated using

$$\text{Average Power Consumption} = (t_{ON} \times I_{AVG\_ON} + t_{OFF} \times I_{POWERDOWN}) / (t_{ON} + t_{OFF})$$

Using a sequenced power-on routine like that illustrated in Figure 39 can reduce the  $I_{AVG\_ON}$  current and, hence, reduce the overall power consumption. When used in conjunction with a large duty-cycle or large  $t_{OFF}$ , this can result in significantly increased battery life. Analog Devices, Inc., free design tool, [ADIsimSRD Design Studio](#), can assist in these calculations.

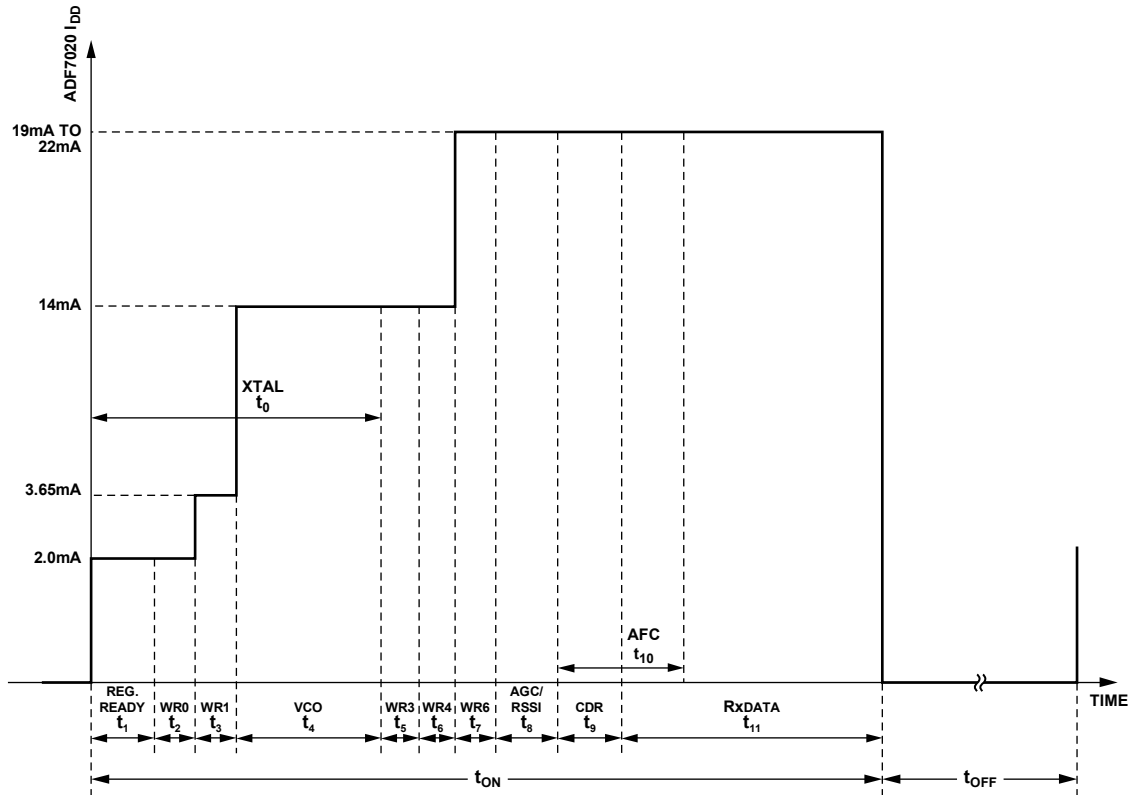

Figure 39. Rx Programming Sequence and Timing Diagram

Table 11. Power-Up Sequence Description

Parameter	Value	Description	Signal to Monitor
$t_0$	2 ms	Crystal starts power-up after CE is brought high. This typically depends on the crystal type and the load capacitance specified.	CLKOUT pin
$t_1$	10 $\mu$ s	Time for regulator to power up. The serial interface can be written to after this time.	MUXOUT pin
$t_2, t_3, t_5, t_6, t_7$	$32 \times 1/SPI\_CLK$	Time to write to a single register. Maximum SPI_CLK is 25 MHz.	
$t_4$	1 ms	The VCO can power-up in parallel with the crystal. This depends on the CVCO capacitance value used. A value of 22 nF is recommended as a trade-off between phase noise performance and power-up time.	CVCO pin
$t_8$	150 $\mu$ s	This depends on the number of gain changes the AGC loop needs to cycle through and AGC settings programmed. This is described in more detail in the AGC Information and Timing section.	Analog RSSI on TEST_A pin (Available by writing 0x3800 000C)
$t_9$	$5 \times BIT\_PERIOD$	This is the time for the clock and data recovery circuit to settle. This typically requires 5-bit transitions to acquire sync and is usually covered by the preamble.	
$t_{10}$	$48 \times BIT\_PERIOD$	This is the time for the automatic frequency control circuit to settle. This typically requires 48-bit transitions to acquire lock and is usually covered by an appropriate length preamble.	
$t_{11}$	Packet Length	Number of bits in payload by the bit period.	

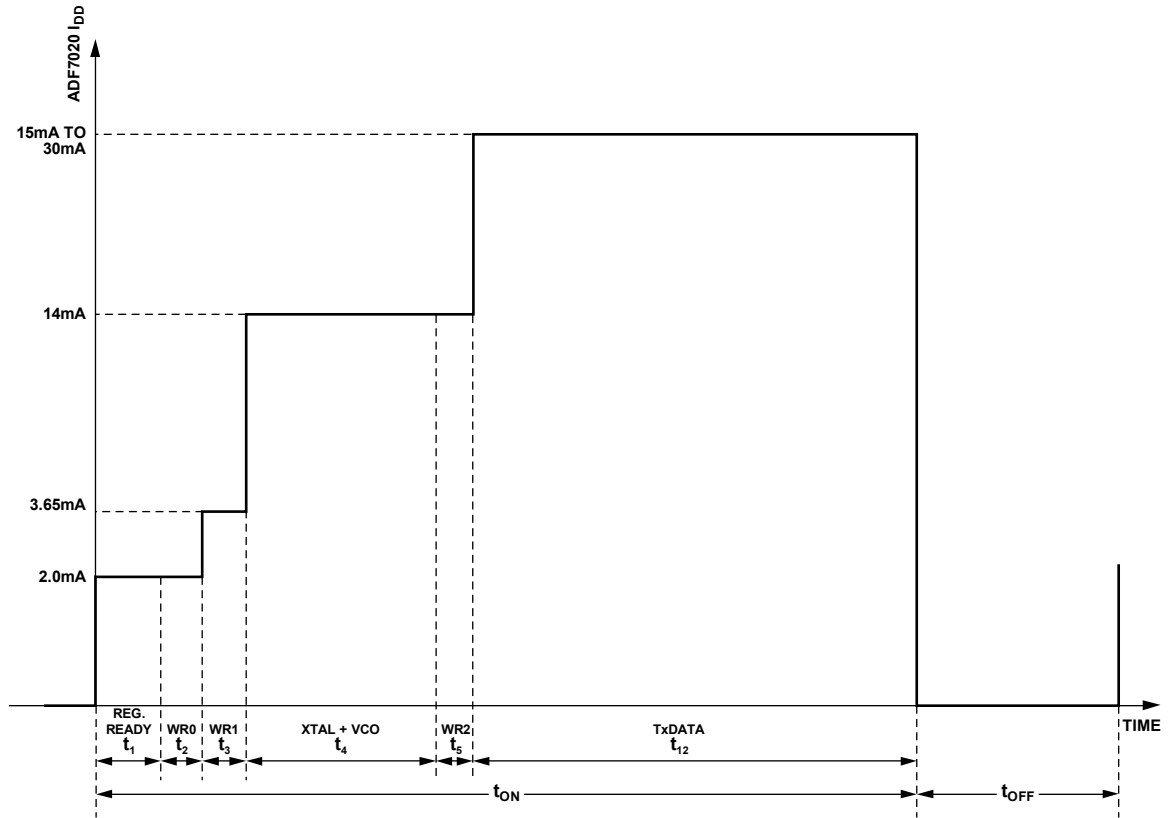

Figure 40. Tx Programming Sequence and Timing Diagram

06351-038

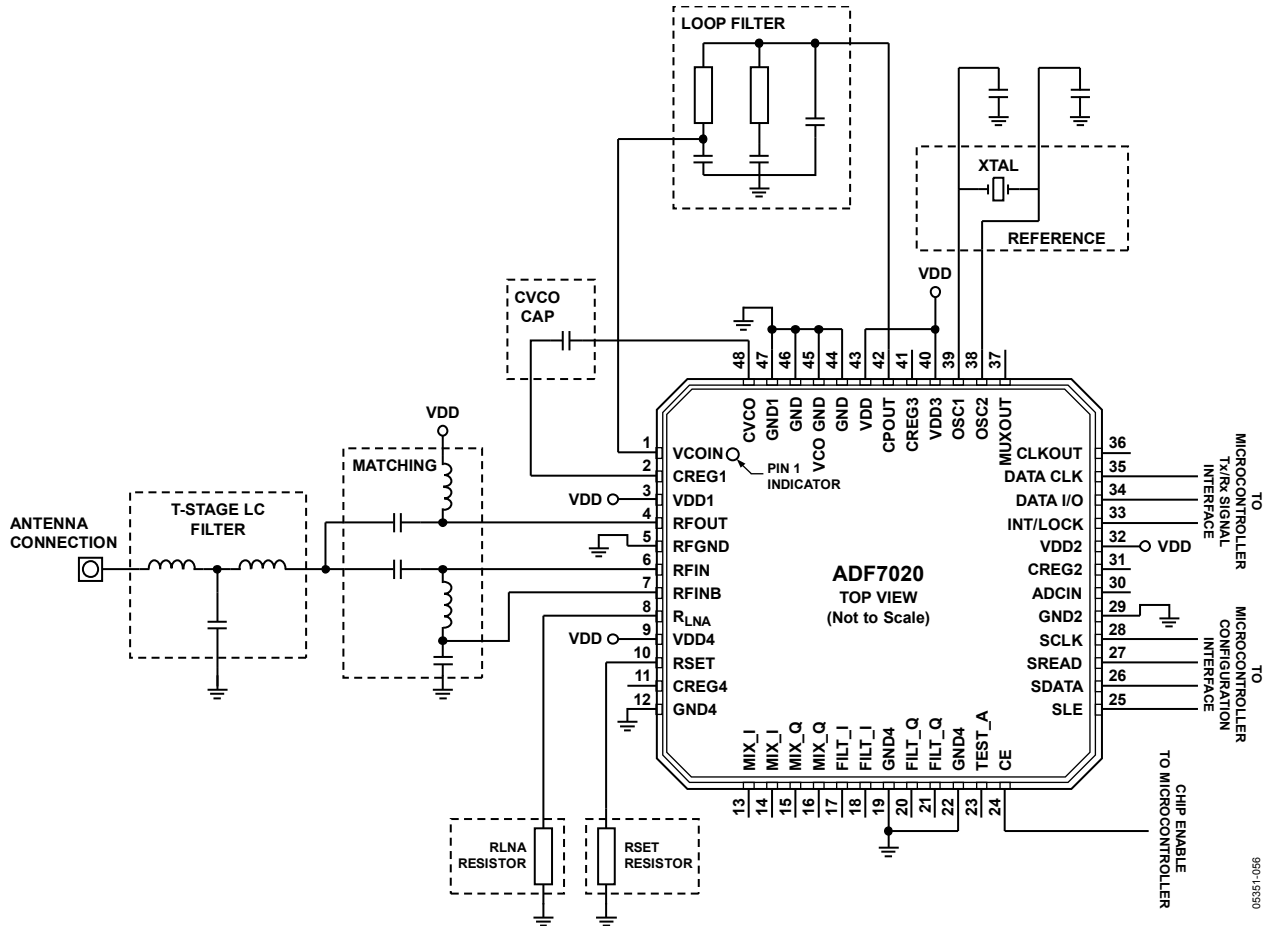

Figure 41. Application Circuit

96551-06

## SERIAL INTERFACE

The serial interface allows the user to program the fourteen 32-bit registers using a 3-wire interface (SCLK, SDATA, and SLE). Signals should be CMOS compatible. The serial interface is powered by the regulator and, therefore, is inactive when CE is low.

Data is clocked into the register, MSB first, on the rising edge of each clock (SCLK). Data is transferred to one of fourteen latches on the rising edge of SLE. The destination latch is determined by the value of the four control bits (C4 to C1). These are the bottom four LSBs, DB3 to DB0, as shown in the timing diagram in Figure 3.

### READBACK FORMAT

The readback operation is initiated by writing a valid control word to the readback register and setting the readback enable bit (R7\_DB8 = 1). The readback can begin after the control word has been latched with the SLE signal. SLE must be kept high while the data is being read out. Each active edge at the SCLK pin clocks the readback word out successively at the SREAD pin (see Figure 42), starting with the MSB first. The data appearing at the first clock cycle following the latch operation must be ignored. The last (eighteenth) SCLK edge puts the SREAD pin back in three-state.

#### AFC Readback

The AFC readback is valid only during the reception of FSK signals with either the linear or correlator demodulator active. The AFC readback value is formatted as a signed 16-bit integer comprising Bit RV1 to Bit RV16 and is scaled according to the following formula:

$$FREQ\_RB [Hz] = (AFC\_READBACK \times DEMOD\_CLK) / 2^{15}$$

In the absence of frequency errors, the FREQ\_RB value is equal to the IF frequency of 200 kHz. Note that, for the AFC readback to yield a valid result, the down-converted input signal must not fall outside the bandwidth of the analog IF filter. At low input signal levels, the variation in the readback value can be improved by averaging.

#### RSSI Readback

The RSSI readback operation yields valid results in Rx mode with ASK or FSK signals. The format of the readback word is shown in Figure 42. It comprises the RSSI level information (Bit RV1 to Bit RV7), the current filter gain (FG1, FG2), and the current LNA gain (LG1, LG2) setting. The filter and LNA gain are coded in accordance with the definitions in Register 9. With the reception of ASK modulated signals, averaging of the measured RSSI values improves accuracy. The input power can be calculated from the RSSI readback value as outlined in the RSSI/AGC section.

#### Battery Voltage/ADCIN/Temperature Sensor Readback

These three ADC readback values are valid by just enabling the ADC in Register 8 without writing to the other registers. The battery voltage is measured at Pin VDD4. The readback information is contained in Bit RV1 to Bit RV7. This also applies for the readback of the voltage at the ADCIN pin and the temperature sensor. From the readback information, the battery, ADCIN voltage or temperature can be obtained using

$$V_{BATTERY} = (BATTERY\_VOLTAGE\_READBACK) / 21.1$$

$$V_{ADCIN} = (ADCIN\_VOLTAGE\_READBACK) / 42.1$$

$$\text{Temperature} = -40^{\circ}\text{C} + (68.4 - \text{TEMPERATURE\_SENSOR\_READBACK}) \times 9.32$$

#### Silicon Revision Readback

The silicon revision word is coded with four quartets in BCD format. The product code (PC) is coded with three quartets extending from Bit RV5 to Bit RV16. The revision code (RV) is coded with one quartet extending from Bit RV1 to Bit RV4. The product code for the ADF7020 should read back as PC = 0x200. The current revision code should read as RV = 0x8.

#### Filter Calibration Readback

The filter calibration readback word is contained in Bit RV1 to Bit RV8 and is for diagnostic purposes only. Using the automatic filter calibration function, accessible through Register 6, is recommended. Before filter calibration is initiated, decimal 32 should be read back as the default value.

READBACK MODE	READBACK VALUE															
	DB15	DB14	DB13	DB12	DB11	DB10	DB9	DB8	DB7	DB6	DB5	DB4	DB3	DB2	DB1	DB0
AFC READBACK	RV16	RV15	RV14	RV13	RV12	RV11	RV10	RV9	RV8	RV7	RV6	RV5	RV4	RV3	RV2	RV1
RSSI READBACK	X	X	X	X	X	LG2	LG1	FG2	FG1	RV7	RV6	RV5	RV4	RV3	RV2	RV1
BATTERY VOLTAGE/ADCIN/TEMP. SENSOR READBACK	X	X	X	X	X	X	X	X	X	RV7	RV6	RV5	RV4	RV3	RV2	RV1
SILICON REVISION	RV16	RV15	RV14	RV13	RV12	RV11	RV10	RV9	RV8	RV7	RV6	RV5	RV4	RV3	RV2	RV1
FILTER CAL READBACK	0	0	0	0	0	0	0	0	RV8	RV7	RV6	RV5	RV4	RV3	RV2	RV1

Figure 42. Readback Value Table

05351-039

# REGISTERS

## REGISTER 0—N REGISTER

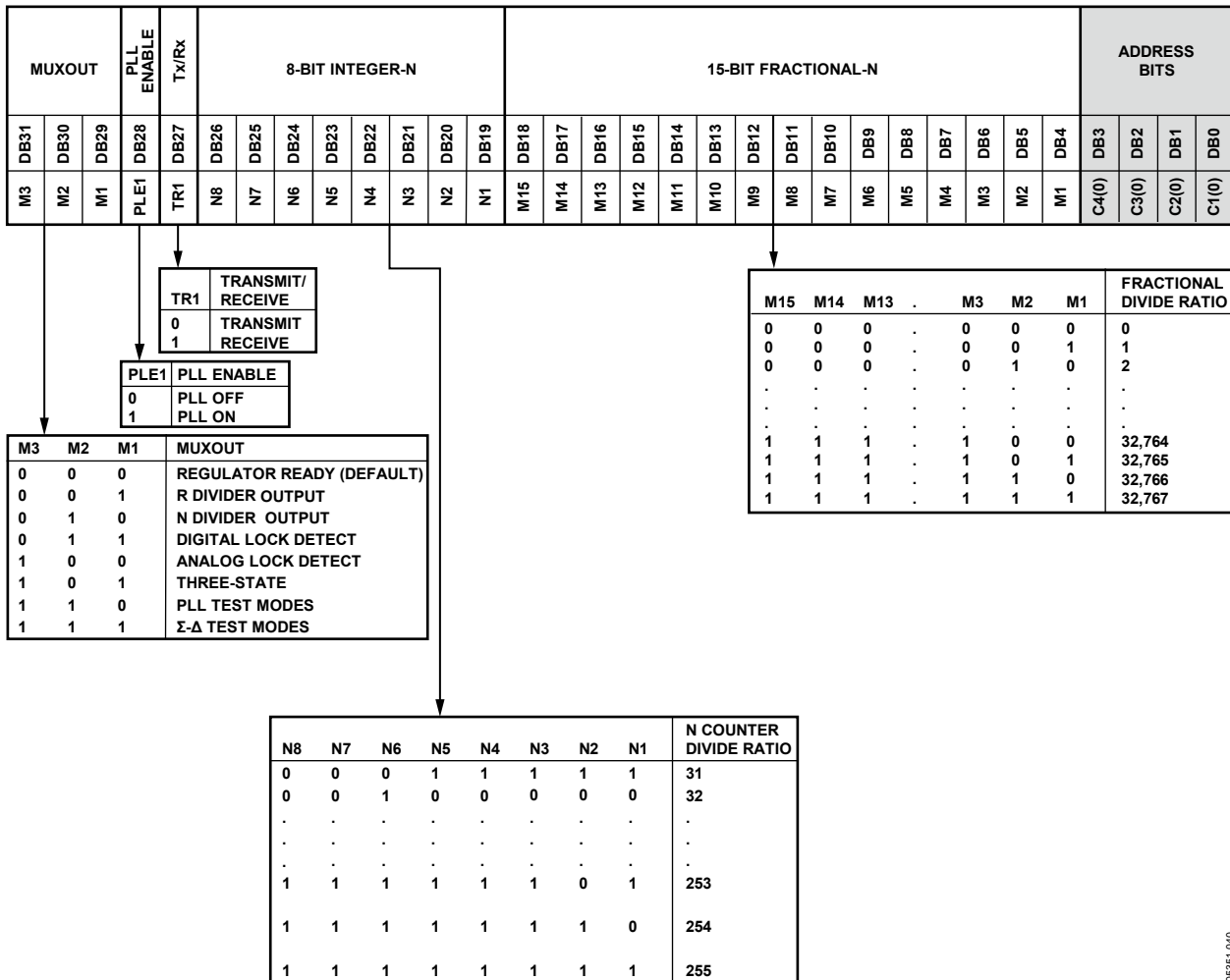

Figure 43. Register 0—N Register

### Register 0—N Register Comments

- The Tx/Rx bit (R0\_DB27) configures the part in Tx or Rx mode and controls the state of the internal Tx/Rx switch.
- $$f_{OUT} = \frac{XTAL}{R} \times \left( INTEGER\_N + \frac{FRACTIONAL\_N}{2^{15}} \right)$$
- If operating in 433 MHz band, with the VCO band bit set, the desired frequency,  $f_{OUT}$ , should be programmed to be twice the desired operating frequency, due to removal of the divide-by-2 stage in the feedback path.

REGISTER 1—OSCILLATOR/FILTER REGISTER

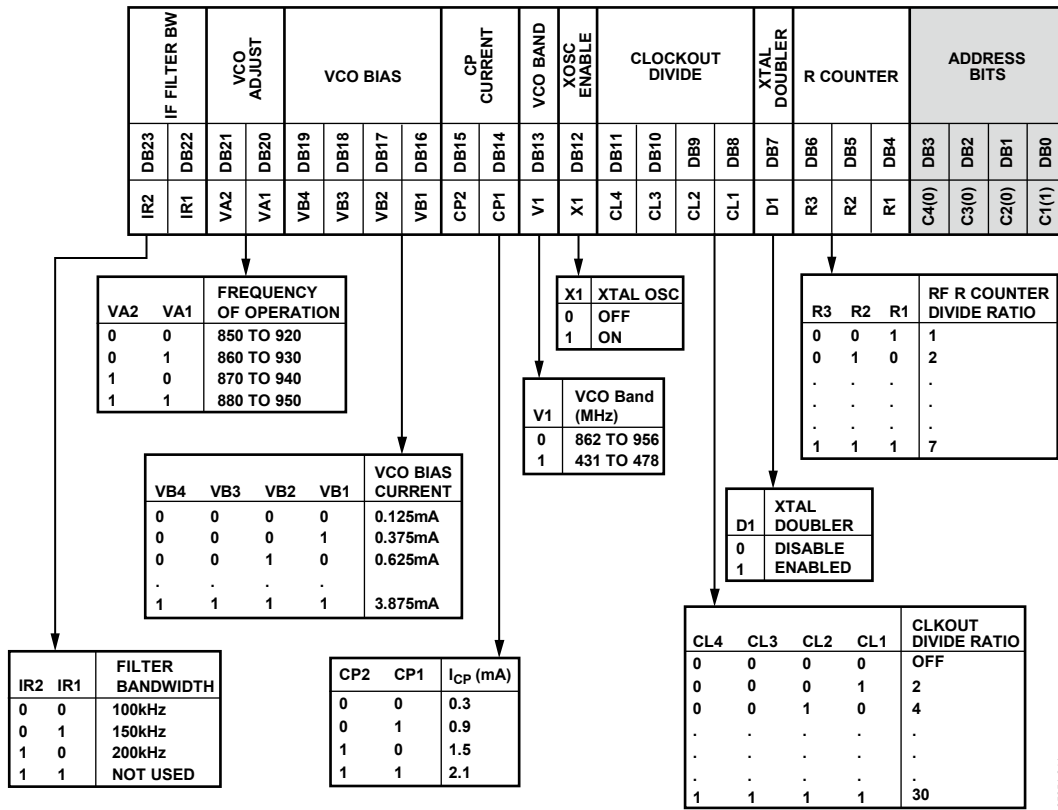
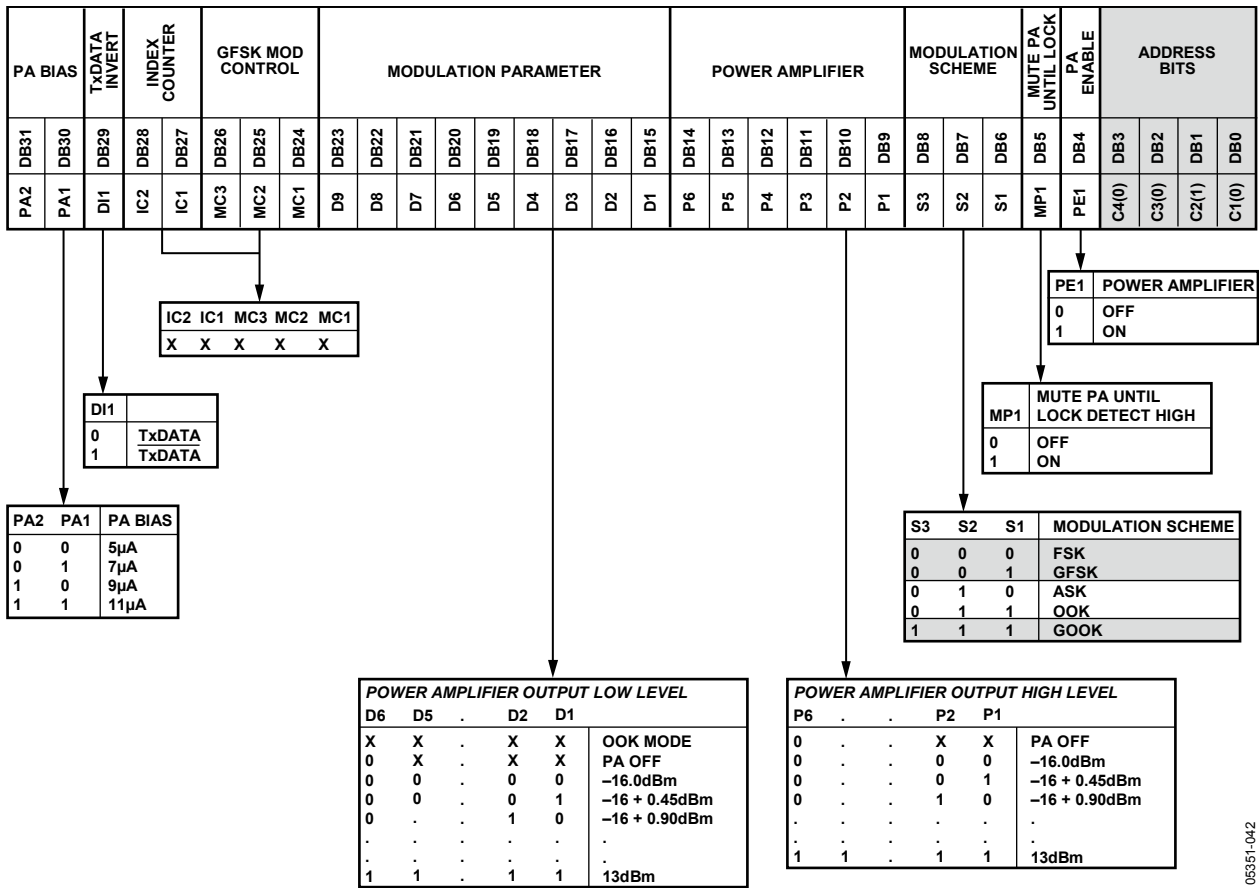

Figure 44. Register 1—Oscillator/Filter Register

Register 1—Oscillator/Filter Register Comments

- The VCO Adjust Bits R1\_DB[20:21] should be set to 0 for operation in the 862 MHz to 870 MHz band and set to 3 for operation in the 902 MHz to 928 MHz band.
- The VCO bias setting should be 0xA for operation in the 862 MHz to 870 MHz and 902 MHz to 928 MHz bands. All VCO gain numbers are specified for these VCO Adjust and Bias settings.

REGISTER 2—TRANSMIT MODULATION REGISTER (ASK/OOK MODE)



06351-042

Figure 45. Register 2—Transmit Modulation Register (ASK/OOK Mode)

Register 2—Transmit Modulation Register (ASK/OOK Mode) Comments

- See the Transmitter section for a description of how the PA bias affects the power amplifier level. The default level is 9 µA. If maximum power is needed, program this value to 11 µA.
- See Figure 13.
- D7, D8, and D9 are don't care bits.

**REGISTER 2—TRANSMIT MODULATION REGISTER (FSK MODE)**

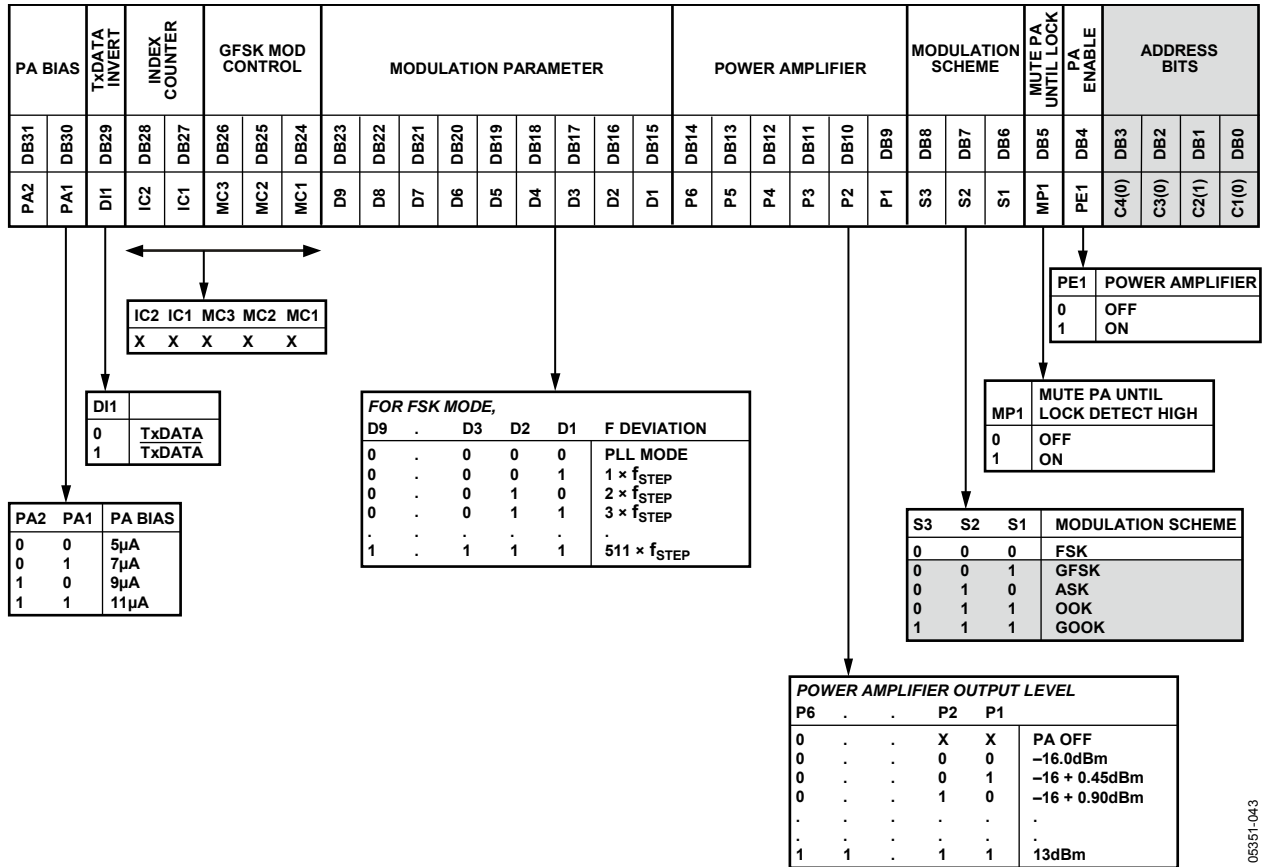

06351-043

Figure 46. Register 2—Transmit Modulation Register (FSK Mode)

**Register 2—Transmit Modulation Register (FSK Mode) Comments**

- $f_{STEP} = PFD/2^{14}$ .
- When operating in the 431 MHz to 478 MHz band,  $f_{STEP} = PFD/2^{15}$ .
- PA bias default = 9 µA.

REGISTER 2—TRANSMIT MODULATION REGISTER (GFSK/GOOK MODE)

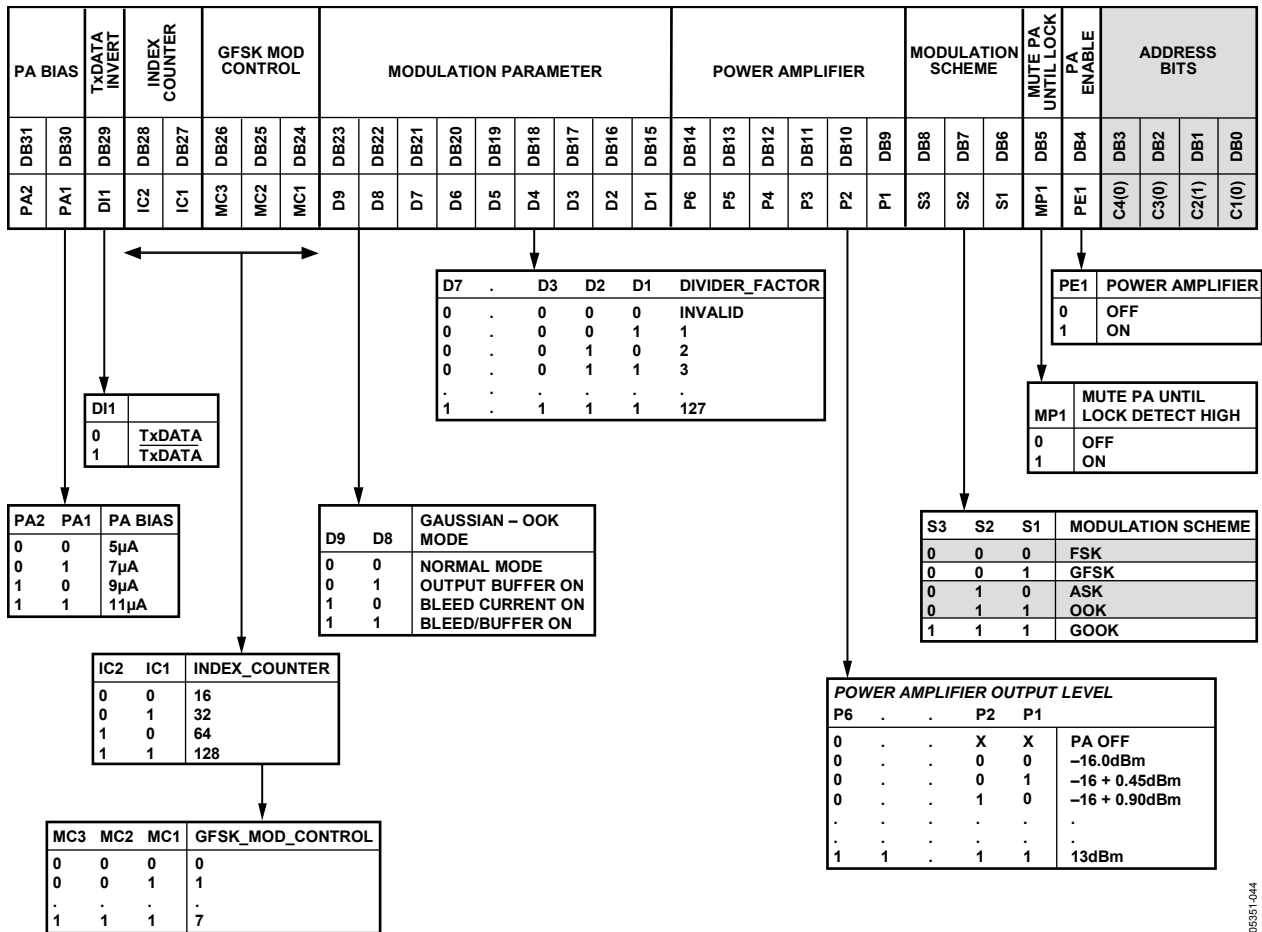

Figure 47. Register 2—Transmit Modulation Register (GFSK/GOOK Mode)

Register 2—Transmit Modulation Register (GFSK/GOOK Mode) Comments

- $GFSK\_DEVIATION = (2^{GFSK\_MOD\_CONTROL} \times PFD) / 2^{12}$ .
- When operating in the 431 MHz to 478 MHz band,  $GFSK\_DEVIATION = (2^{GFSK\_MOD\_CONTROL} \times PFD) / 2^{13}$ .
- $Data\ Rate = PFD / (INDEX\_COUNTER \times DIVIDER\_FACTOR)$ .
- PA Bias default = 9 µA.

**REGISTER 3—RECEIVER CLOCK REGISTER**

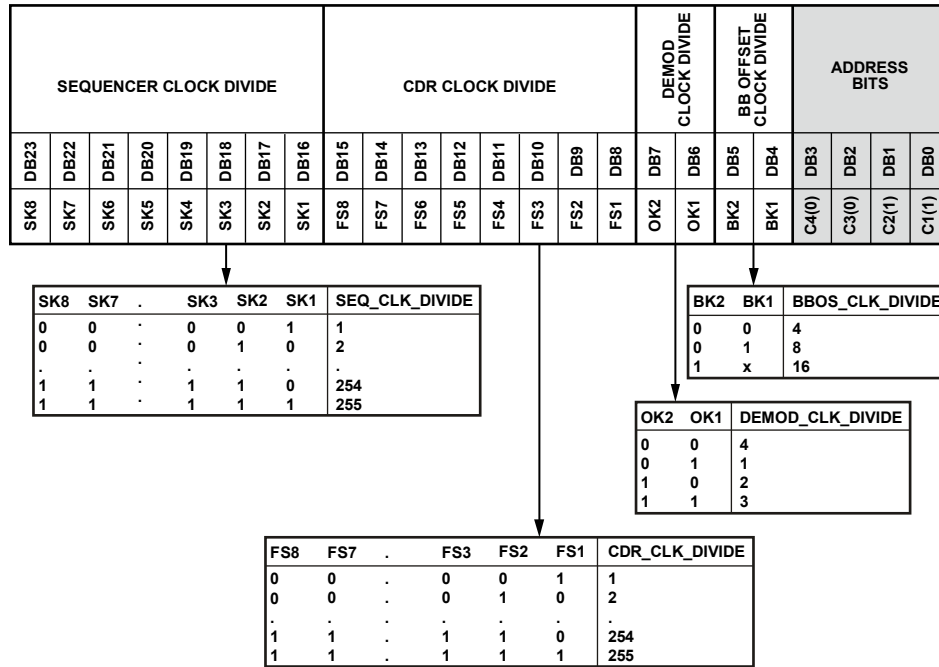

Figure 48. Register 3—Receiver Clock Register

05381-045

**Register 3—Receiver Clock Register Comments**

- Baseband offset clock frequency (BBOS\_CLK) must be greater than 1 MHz and less than 2 MHz, where

$$BBOS\_CLK = \frac{XTAL}{BBOS\_CLK\_DIVIDE}$$

- The demodulator clock (DEMOD\_CLK) must be <12 MHz for FSK and <6 MHz for ASK, where

$$DEMOD\_CLK = \frac{XTAL}{DEMOD\_CLK\_DIVIDE}$$

- Data/clock recovery frequency (CDR\_CLK) should be within 2% of (32 × data rate), where

$$CDR\_CLK = \frac{DEMOD\_CLK}{CDR\_CLK\_DIVIDE}$$

Note that this can affect your choice of XTAL, depending on the desired data rate.

- The sequencer clock (SEQ\_CLK) supplies the clock to the digital receive block. It should be close to 100 kHz for FSK and close to 40 kHz for ASK.

$$SEQ\_CLK = \frac{XTAL}{SEQ\_CLK\_DIVIDE}$$

REGISTER 4—DEMODULATOR SETUP REGISTER

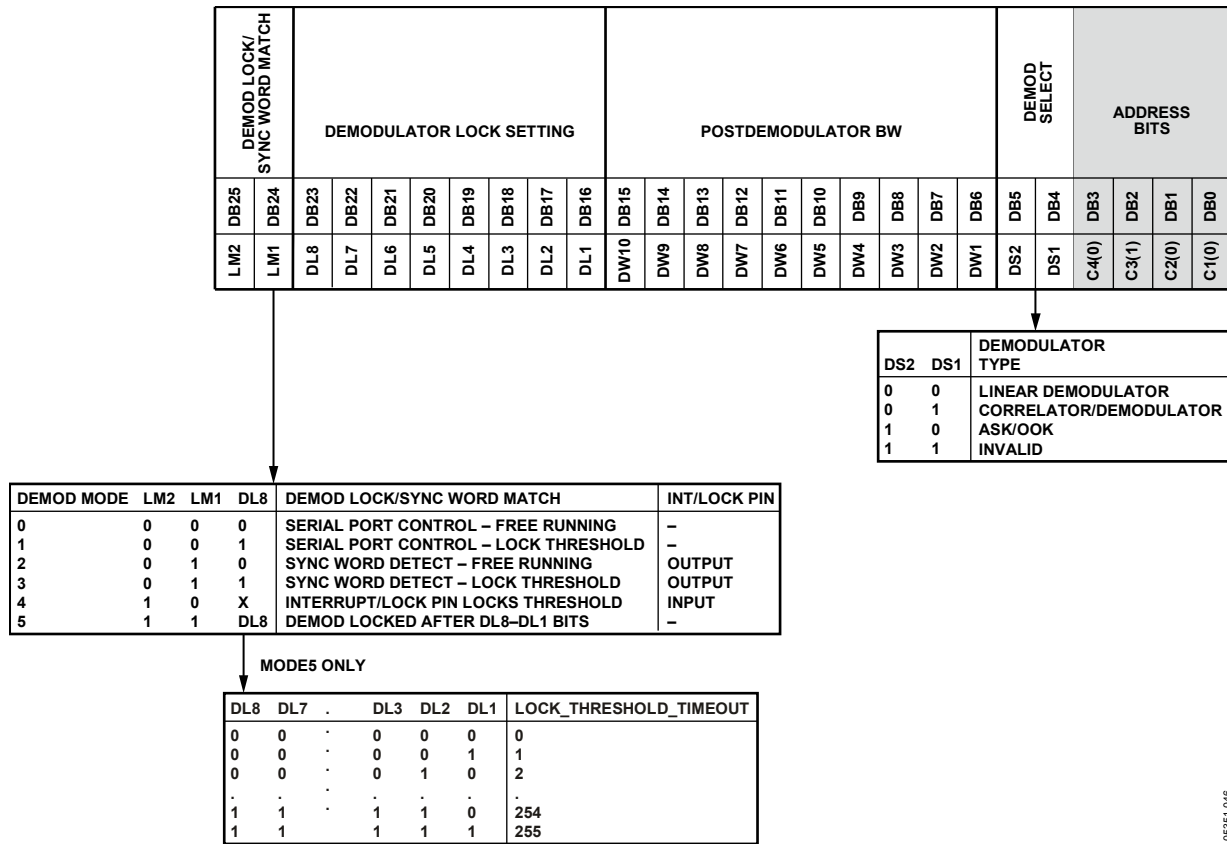

Figure 49. Register 4—Demodulator Setup Register

**Register 4—Demodulator Setup Register Comments**

- Demodulator Mode 1, Demodulator Mode 3, Demodulator Mode 4, and Demodulator Mode 5 are modes that can be activated to allow the ADF7020 to demodulate data-encoding schemes that have run-length constraints greater than 7, when using the linear demodulator.
- $$POSTDEMODO\_BW = \frac{2^{11} \times \pi \times f_{CUTOFF}}{DEMODO\_CLK}$$
 where the cutoff frequency ( $f_{CUTOFF}$ ) of the postdemodulator filter should typically be 0.75 times the data rate.
- For Mode 5,  $Timeout\ Delay\ to\ Lock\ Threshold = (LOCK\_THRESHOLD\_SETTING)/SEQ\_CLK$  where  $SEQ\_CLK$  is defined in the Register 3—Receiver Clock Register section.

05351-046

**REGISTER 5—SYNC BYTE REGISTER**

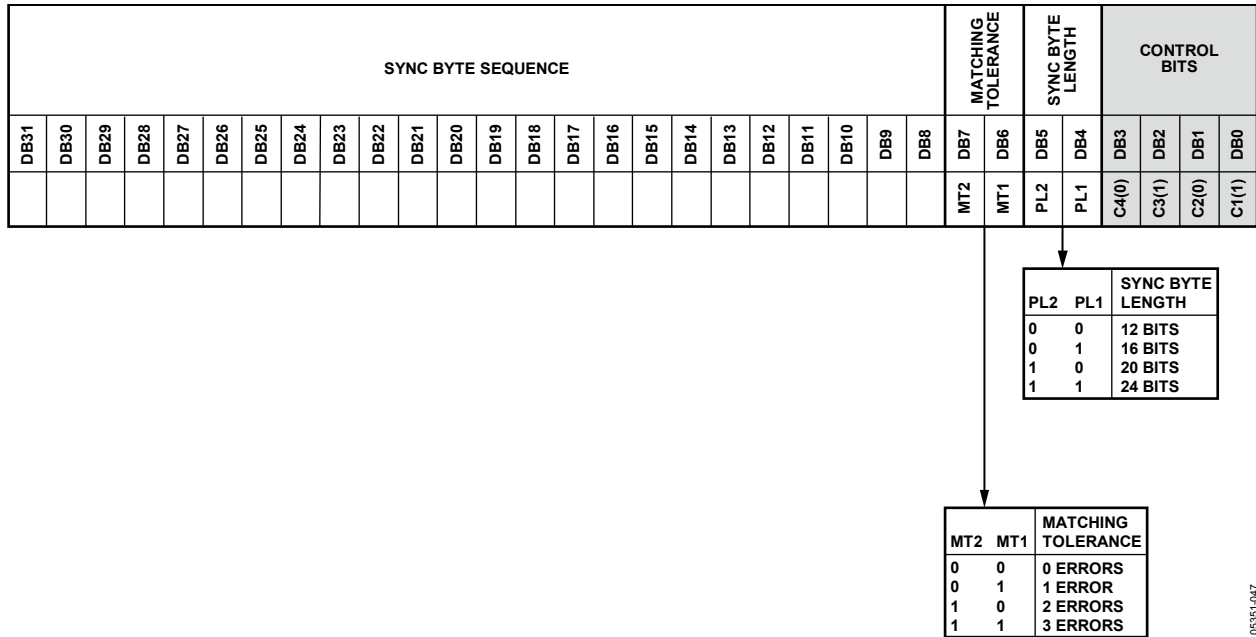

Figure 50. Register 5—Sync Byte Register

0351-1047

**Register 5—Sync Byte Register Comments**

- Sync byte detect is enabled by programming Bits R4\_DB[25:23] to 010 or 011.
- This register allows a 24-bit sync byte sequence to be stored internally. If the sync byte detect mode is selected, then the INT/LOCK pin goes high when the sync byte is detected in Rx mode. Once the sync word detect signal goes high, it goes low again after nine data bits.
- The transmitter must transmit the MSB of the sync byte first and the LSB last to ensure proper alignment in the receiver sync byte detection hardware.
- Choose a sync byte pattern that has good autocorrelation properties, for example, 0x123456.

REGISTER 6—CORRELATOR/DEMODULATOR REGISTER

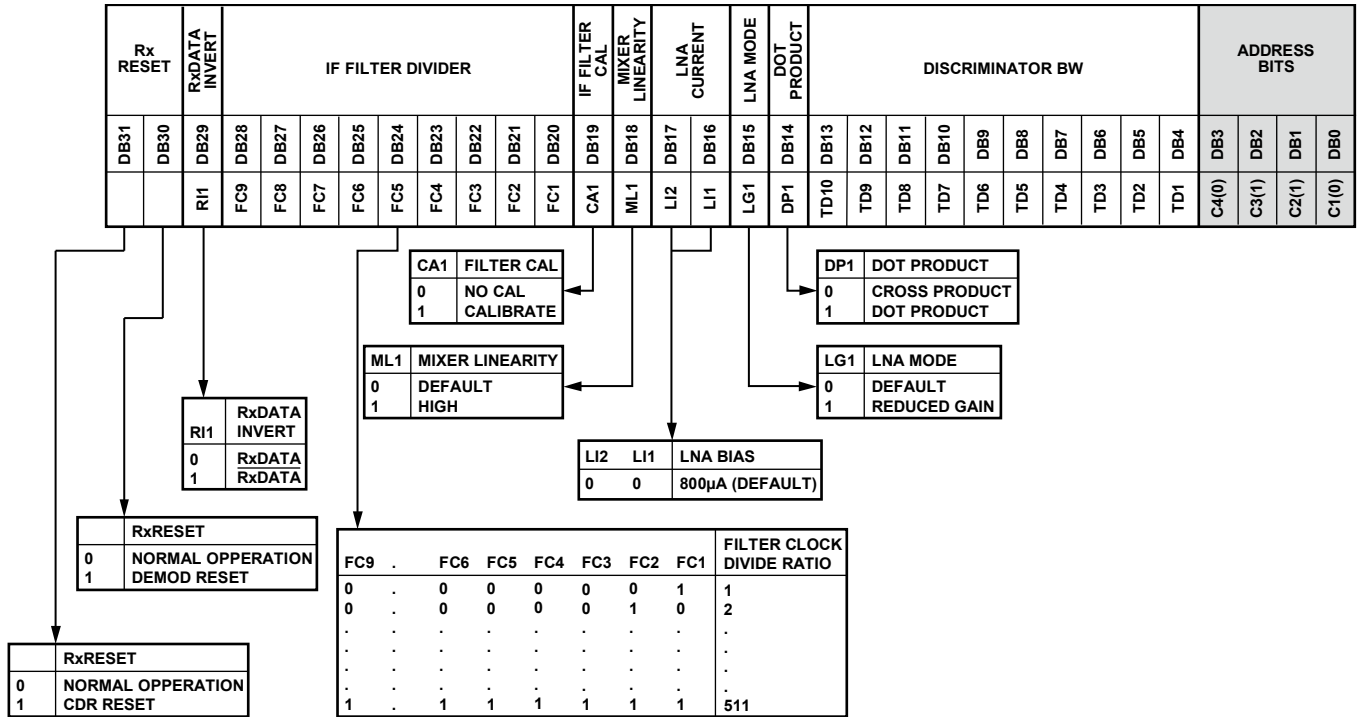

Figure 51. Register 6—Correlator/Demodulator Register

Register 6—Correlator/Demodulator Register Comments

- See the FSK Correlator/Demodulator section for an example of how to determine register settings.
- Nonadherence to correlator programming guidelines results in poorer sensitivity.
- The filter clock is used to calibrate the IF filter. The filter clock divide ratio should be adjusted so that the frequency is 50 kHz. The formula is XTAL/FILTER\_CLOCK\_DIVIDE.
- The filter should be calibrated only when the crystal oscillator is settled. The filter calibration is initiated every time Bit R6\_DB19 is set high.
- $DISCRIMINATOR\_BW = (DEMOM\_CLK \times K) / (800 \times 10^3)$ . See the FSK Correlator/Demodulator section. *Maximum value* = 600.
- When LNA mode = 1 (reduced gain mode), the Rx is prevented from selecting the highest LNA gain setting. This can be used when linearity is a concern. See Table 5 for details of the different Rx modes.

05351-046

**REGISTER 7—READBACK SETUP REGISTER**

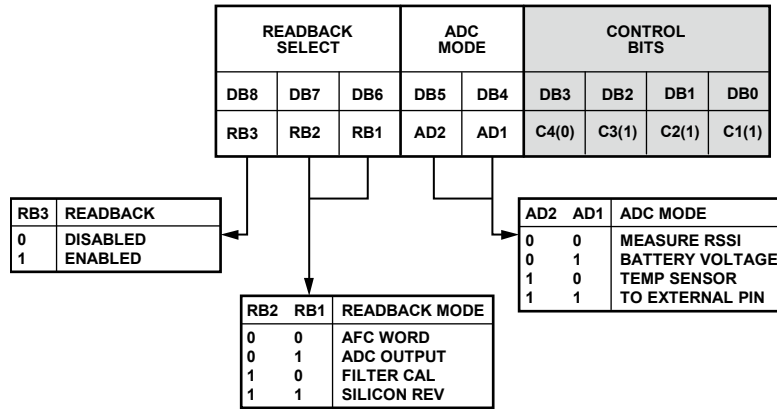

Figure 52. Register 7—Readback Setup Register

**Register 7—Readback Setup Register Comments**

- Readback of the measured RSSI value is valid only in Rx mode. To enable readback of the battery voltage, the temperature sensor, or the voltage at the external pin in Rx mode, AGC function in Register 9 must be disabled. To read back these parameters in Tx mode, the ADC must first be powered up using Register 8 because this is off by default in Tx mode to save power. This is the recommended method of using the battery readback function because most configurations typically require AGC.
- Readback of the AFC word is valid in Rx mode only if either the linear demodulator or the correlator/demodulator is active.
- See the Readback Format section for more information.

REGISTER 8—POWER-DOWN TEST REGISTER

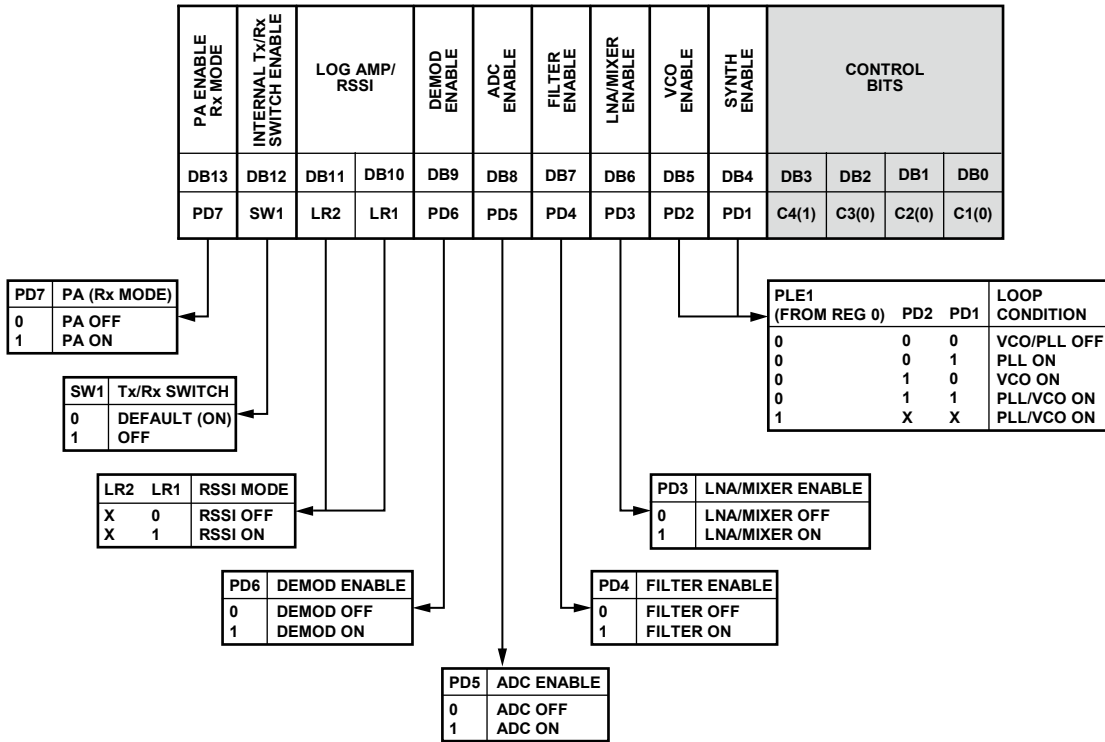

Figure 53. Register 8—Power-Down Test Register

05351-050

**Register 8—Power-Down Test Register Comments**

- For a combined LNA/PA matching network, Bit R8\_DB12 should always be set to 0. This is the power-up default condition.
- It is not necessary to write to this register under normal operating conditions.

REGISTER 9—AGC REGISTER

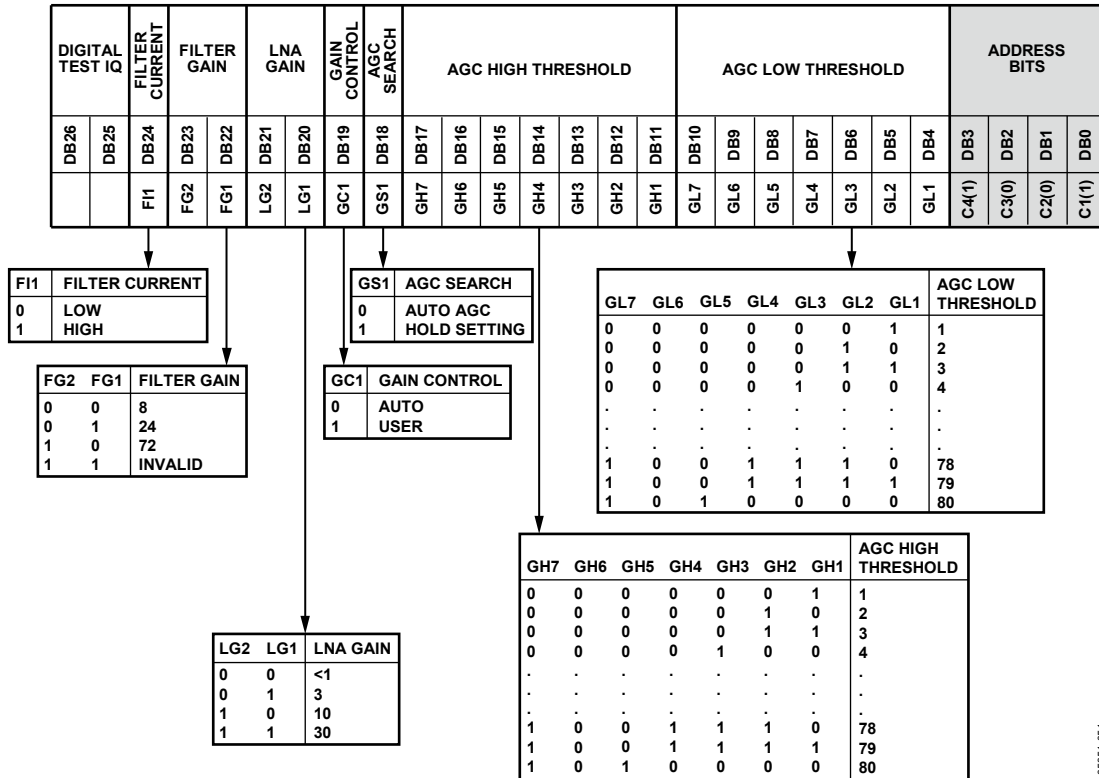

05351-061

Figure 54. Register 9—AGC Register

Register 9—AGC Register Comments

- This register does not need to be programmed in normal operation. Default AGC\_LOW\_THRESHOLD = 30, default AGC\_HIGH\_THRESHOLD = 70. See the RSSI/AGC section for details. Default register setting = 0xB2 31E9.
- AGC high and low settings must be more than 30 apart to ensure correct operation.
- LNA gain of 30 is available only if LNA mode, R6\_DB15, is set to 0.

**REGISTER 10—AGC 2 REGISTER**

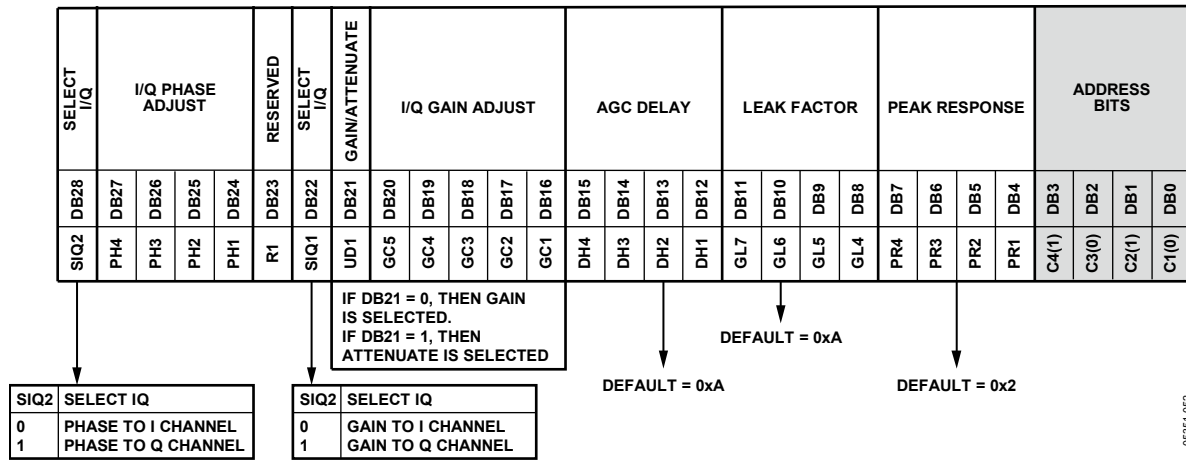

Figure 55. Register 10—AGC 2 Register

**Register 10—AGC 2 Register Comments**

- This register is not used under normal operating conditions.
- For ASK/OOK modulation, the recommended settings for operation over the full input range are peak response = 2, leak factor = 10 (default), and AGC delay = 10 (default). Bit DB31 to Bit DB16 should be cleared. For bit-rates below 4 kbps the AGC\_WAIT\_TIME can be increased by setting the AGC\_DELAY to 15. The SEQ\_CLK should also be set at a minimum.

**REGISTER 11—AFC REGISTER**

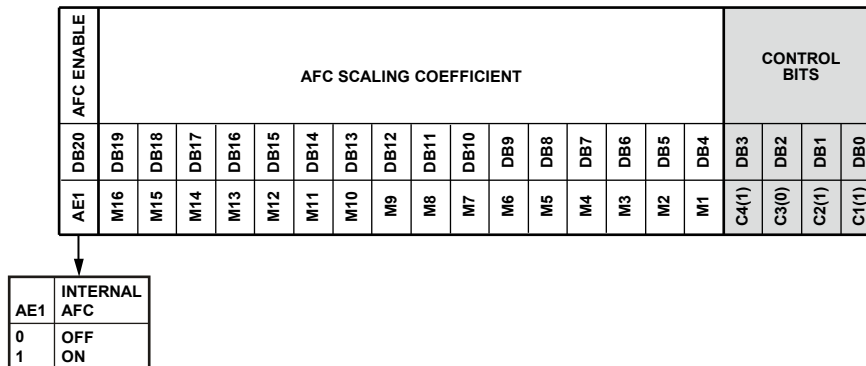

Figure 56. Register 11—AFC Register

**Register 11—AFC Register Comments**

- See the Internal AFC section to program the AFC scaling coefficient bits.
- The AFC scaling coefficient bits can be programmed using the following formula:

$$AFC\_SCALING\_COEFFICIENT = Round((500 \times 2^{24})/XTAL)$$

REGISTER 12—TEST REGISTER

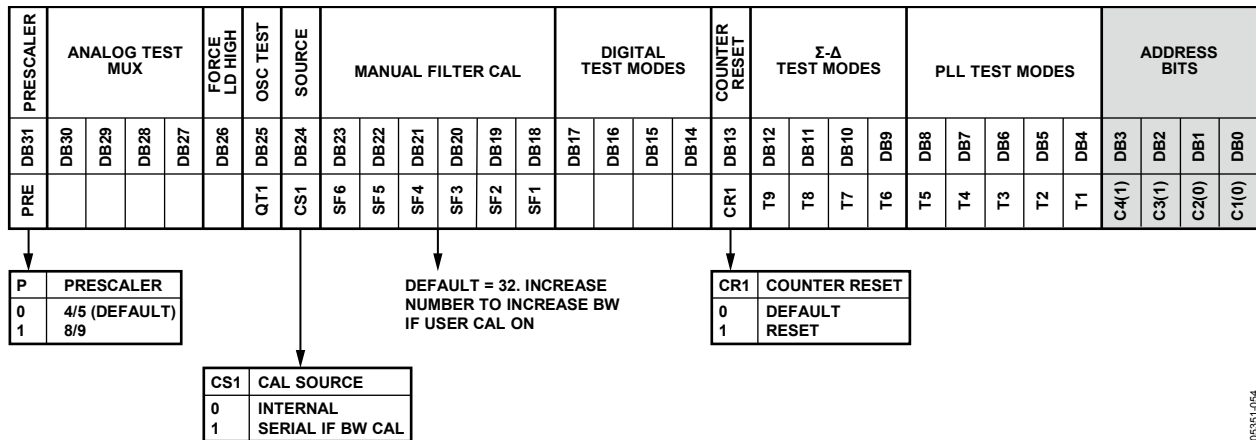

Figure 57. Register 12—Test Register

05351-054

**Register 12—Test Register Comments**

This register does not need to be written to in normal operation. The default test mode is 0x0000 000C, which puts the part in normal operation.

**Using the Test DAC on the ADF7020 to Implement Analog FM Demodulation and Measuring of SNR**

The test DAC allows the output of the postdemodulator filter for both the linear and correlator/demodulators (see Figure 30 and Figure 31) to be viewed externally. It takes the 16-bit filter output and converts it to a high frequency, single-bit output using a second-order Σ-Δ converter. The output can be viewed on the CLKOUT pin. This signal, when filtered appropriately, can then be used to

- Monitor the signals at the FSK/ASK postdemodulator filter output. This allows the demodulator output SNR to be measured. Eye diagrams can also be constructed of the received bit stream to measure the received signal quality.
- Provide analog FM demodulation.

While the correlators and filters are clocked by DEMOD\_CLK, CDR\_CLK clocks the test DAC. Note that although the test DAC functions in a regular user mode, the best performance is achieved when the CDR\_CLK is increased up to or above the frequency of DEMOD\_CLK. The CDR block does not function when this condition exists.

Programming the test register, Register 12, enables the test DAC. In correlator mode, this can be done by writing to Digital Test Mode 7 or 0x0001C00C.

To view the test DAC output when using the linear demodulator, the user must remove a fixed offset term from the signal using Register 13. This offset is nominally equal to the IF frequency. The user can determine the value to program by using the frequency error readback to determine the actual IF and then programming half this value into the offset removal field. It also has a signal gain term to allow the usage of the maximum dynamic range of the DAC.

**Setting Up the Test DAC**

- Digital test modes = 7: enables the test DAC, with no offset removal (0x0001 C00C).
- Digital test modes = 10: enables the test DAC, with offset removal (needed for linear demodulation only, 0x02 800C).

The output of the active demodulator drives the DAC, that is, if the FSK correlator/demodulator is selected, the correlator filter output drives the DAC.

The evaluation boards for the ADF7020 contain land patterns for placement of an RC filter on the CLKOUT line. This is typically designed so that the cut-off frequency of the filter is above the demodulated data rate.

**REGISTER 13—OFFSET REMOVAL AND SIGNAL GAIN REGISTER**

TEST DAC GAIN						TEST DAC OFFSET REMOVAL						PULSE EXTENSION				KI				KP				CONTROL BITS											
DB31	DB30	DB29	DB28	DB27	DB26	DB25	DB24	DB23	DB22	DB21	DB20	DB19	DB18	DB17	DB16	DB15	DB14	DB13	DB12	DB11	DB10	DB9	DB8	DB7	DB6	DB5	DB4	DB3	DB2	DB1	DB0				
																PE4	PE3	PE2	PE1													C4(1)	C3(1)	C2(0)	C1(1)
																KI DEFAULT = 3				KP DEFAULT = 2															

PE4	PE3	PE2	PE1	PULSE EXTENSION
0	0	0	0	NORMAL PULSE WIDTH
0	0	0	1	2 × PULSE WIDTH
0	0	1	0	3 × PULSE WIDTH
.	.	.	.	.
.	.	.	.	.
1	1	1	1	16 × PULSE WIDTH

Figure 58. Register 13—Offset Removal and Signal Gain Register

**Register 13—Offset Removal and Signal Gain Register Comments**

- Because the linear demodulator’s output is proportional to frequency, it usually consists of an offset combined with a relatively low signal. The offset can be removed, up to a maximum of 1.0, and gained to use the full dynamic range of the DAC:  
 $DAC\_INPUT = (2^{TEST\_DAC\_GAIN}) \times (Signal - TEST\_DAC\_OFFSET\_REMOVAL/4096)$
- Ki (default) = 3. Kp (default) = 2.

06351-085

# OUTLINE DIMENSIONS

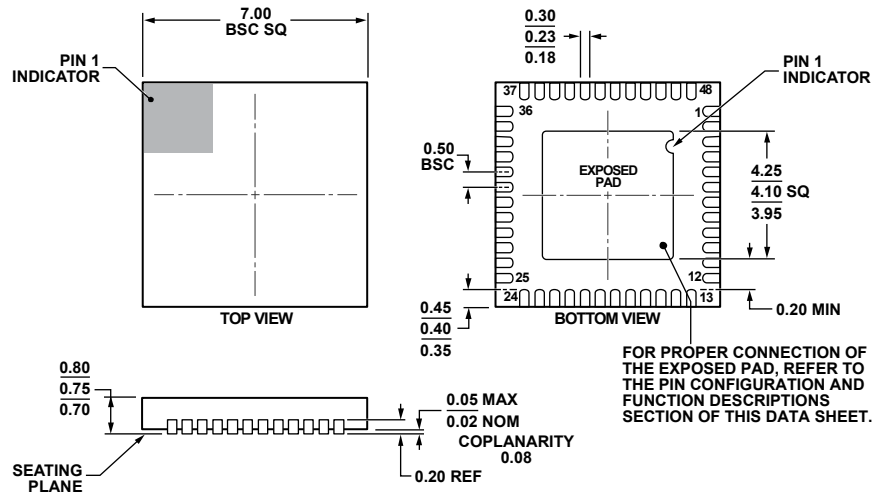

COMPLIANT TO JEDEC STANDARDS MO-220-WKKD.

Figure 59. 48-Lead Lead Frame Chip Scale Package [LFCS<sub>P</sub>\_WQ]  
 7 mm × 7 mm Body, Very Very Thin Quad  
 (CP-48-5)  
 Dimensions shown in millimeters

08-16-2010-B

## ORDERING GUIDE

Model <sup>1</sup>	Temperature Range	Package Description	Package Option <sup>2</sup>
ADF7020BCPZ	-40°C to +85°C	48-Lead Lead Frame Chip Scale Package [LFCS <sub>P</sub> _WQ]	CP-48-5
ADF7020BCPZ-RL	-40°C to +85°C	48-Lead Lead Frame Chip Scale Package [LFCS <sub>P</sub> _WQ]	CP-48-5
EVAL-ADF70xxMBZ2		Evaluation Platform	
EVAL-ADF7020DBZ1		902 MHz to 928 MHz Daughter Board	
EVAL-ADF7020DBZ2		860 MHz to 870 MHz Daughter Board	
EVAL-ADF7020DBZ3		430 MHz to 445 MHz Daughter Board	

<sup>1</sup> Z = RoHS Compliant Part.  
<sup>2</sup> Formerly CP-48-3 package.

## Looking for pricing, stock, or lifecycle information?

Click below to explore more details on WIN SOURCE:

 [View ADF7020BCPZ-RL on WIN SOURCE](#)

 [Analog Devices Inc. Information](#)

## Optimize Your Supply Chain with WIN SOURCE Solutions

-  Global Sourcing Solution
-  Obsolete Management
-  Cost Control Management
-  Shortage Management
-  Alternative Solution
-  Excess Inventory Management