



**THE DATASHEET OF  
ADG1436YRUZ**





### FEATURES

- 1.5 Ω on resistance
- 0.3 Ω on-resistance flatness
- 0.1 Ω on-resistance match between channels
- Continuous current per channel
  - LFCSP package: up to 400 mA
  - TSSOP package: up to 260 mA
- Fully specified at +12 V, ±15 V, and ±5 V
- No V<sub>L</sub> supply required
- 3 V logic-compatible inputs
- Rail-to-rail operation
- 16-lead TSSOP and 4 mm × 4 mm, 16-lead LFCSP packages

### APPLICATIONS

- Automatic test equipment
- Data acquisition systems
- Battery-powered systems
- Sample-and-hold systems
- Audio signal routing
- Communication systems
- Relay replacement

### GENERAL DESCRIPTION

The ADG1436 is a monolithic CMOS device containing two independently selectable SPDT switches. An EN input on the LFCSP package enables or disables the device. When disabled, all channels are switched off. Each switch conducts equally well in both directions when on and has an input signal range that extends to the supplies. In the off condition, signal levels up to the supplies are blocked. Both switches exhibit break-before-make switching action for use in multiplexer applications.

The ADG1436 is designed on an iCMOS® process. iCMOS (industrial-CMOS) is a modular manufacturing process combining high voltage CMOS (complementary metal-oxide semiconductor) and bipolar technologies. It enables the development of a wide range of high performance analog ICs capable of 33 V operation in a footprint that no previous generation of high voltage parts has been able to achieve. Unlike analog ICs using conventional

### FUNCTIONAL BLOCK DIAGRAMS

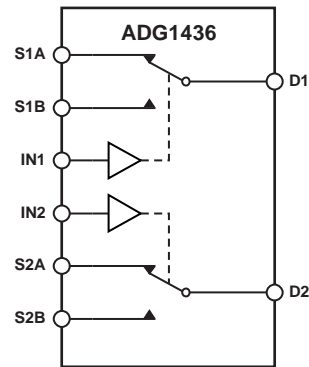

SWITCHES SHOWN FOR A ONE-INPUT LOGIC.

Figure 1. TSSOP Package

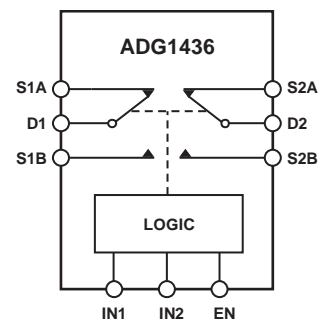

SWITCHES SHOWN FOR A ONE-INPUT LOGIC.

Figure 2. LFCSP Package

CMOS processes, iCMOS components can tolerate high supply voltages while providing increased performance, dramatically lower power consumption, and reduced package size.

The on-resistance profile is very flat over the full analog input range, ensuring excellent linearity and low distortion when switching audio signals. iCMOS construction ensures ultralow power dissipation, making the part ideally suited for portable and battery-powered instruments.

### PRODUCT HIGHLIGHTS

1. 2.6 Ω maximum on resistance over temperature.
2. Minimum distortion.
3. Ultralow power dissipation: <0.03 μW.
4. 16-lead TSSOP and 16-lead 4 mm × 4 mm LFCSP packages.

Rev. B

[Document Feedback](#)

Information furnished by Analog Devices is believed to be accurate and reliable. However, no responsibility is assumed by Analog Devices for its use, nor for any infringements of patents or other rights of third parties that may result from its use. Specifications subject to change without notice. No license is granted by implication or otherwise under any patent or patent rights of Analog Devices. Trademarks and registered trademarks are the property of their respective owners.

**TABLE OF CONTENTS**

Features .....	1	Continuous Current per Channel.....	6
Applications.....	1	Absolute Maximum Ratings .....	7
Functional Block Diagrams.....	1	ESD Caution.....	7
General Description .....	1	Pin Configurations and Function Descriptions .....	8
Product Highlights .....	1	Truth Table For Switches .....	8
Revision History .....	2	Typical Performance Characteristics .....	9
Specifications.....	3	Terminology .....	12
15 V Dual Supply.....	3	Test Circuits.....	13
12 V Single Supply.....	4	Outline Dimensions .....	16
5 V Dual Supply.....	5	Ordering Guide .....	16

**REVISION HISTORY**

**9/2016—Rev. A to Rev. B**

Changes to Figure 4.....	8
Updated Outline Dimensions.....	16
Changes to Ordering Guide .....	16

**3/2009—Rev. 0 to Rev. A**

Change to I <sub>DD</sub> Parameter, Table 1 .....	3
Change to I <sub>DD</sub> Parameter, Table 2 .....	4

**7/2008—Revision 0: Initial Version**

## SPECIFICATIONS

## 15 V DUAL SUPPLY

$V_{DD} = 15\text{ V} \pm 10\%$ ,  $V_{SS} = -15\text{ V} \pm 10\%$ , GND = 0 V, unless otherwise noted.

Table 1.

Parameter	25°C	-40°C to +85°C	-40°C to +125°C	Unit	Test Conditions/Comments
<b>ANALOG SWITCH</b>					
Analog Signal Range			$V_{DD}$ to $V_{SS}$	V	
On Resistance ( $R_{ON}$ )	1.5			$\Omega$ typ	$V_S = \pm 10\text{ V}$ , $I_S = -10\text{ mA}$ ; see Figure 23
	1.8	2.3	2.6	$\Omega$ max	$V_{DD} = +13.5\text{ V}$ , $V_{SS} = -13.5\text{ V}$
On-Resistance Match Between Channels ( $\Delta R_{ON}$ )	0.1			$\Omega$ typ	$V_S = \pm 10\text{ V}$ , $I_S = -10\text{ mA}$
	0.18	0.19	0.21	$\Omega$ max	
On-Resistance Flatness ( $R_{FLAT(ON)}$ )	0.28			$\Omega$ typ	$V_S = \pm 10\text{ V}$ , $I_S = -10\text{ mA}$
	0.36	0.4	0.45	$\Omega$ max	
<b>LEAKAGE CURRENTS</b>					
Source Off Leakage, $I_S$ (Off)	$\pm 0.04$			nA typ	$V_{DD} = +16.5\text{ V}$ , $V_{SS} = -16.5\text{ V}$
	$\pm 0.55$	$\pm 2$	$\pm 12.5$	nA max	$V_S = \pm 10\text{ V}$ , $V_D = \pm 10\text{ V}$ ; see Figure 24
Drain Off Leakage, $I_D$ (Off)	$\pm 0.04$			nA typ	
	$\pm 0.55$	$\pm 2$	$\pm 12.5$	nA max	$V_S = \pm 10\text{ V}$ , $V_D = \pm 10\text{ V}$ ; see Figure 24
Channel On Leakage, $I_D$ , $I_S$ (On)	$\pm 0.1$			nA typ	$V_S = V_D = \pm 10\text{ V}$ ; see Figure 25
	$\pm 2$	$\pm 4$	$\pm 35$	nA max	
<b>DIGITAL INPUTS</b>					
Input High Voltage, $V_{INH}$			2.0	V min	
Input Low Voltage, $V_{INL}$			0.8	V max	
Input Current, $I_{INL}$ or $I_{INH}$	0.005			$\mu\text{A}$ typ	$V_{IN} = V_{GND}$ or $V_{DD}$
			$\pm 0.1$	$\mu\text{A}$ max	
Digital Input Capacitance, $C_{IN}$	3.5			pF typ	
<b>DYNAMIC CHARACTERISTICS<sup>1</sup></b>					
Transition Time, $t_{TRANSITION}$	125			ns typ	$R_L = 300\ \Omega$ , $C_L = 35\text{ pF}$
	170	215	245	ns max	$V_S = +10\text{ V}$ ; see Figure 30
$t_{ON}$ (EN)	95			ns typ	$R_L = 300\ \Omega$ , $C_L = 35\text{ pF}$
	120	140	155	ns max	$V_S = 10\text{ V}$ ; see Figure 30
$t_{OFF}$ (EN)	105			ns typ	$R_L = 300\ \Omega$ , $C_L = 35\text{ pF}$
	130	150	170	ns max	$V_S = 10\text{ V}$ ; see Figure 30
Break-Before-Make Time Delay, $t_{BBM}$	20			ns typ	$R_L = 300\ \Omega$ , $C_L = 35\text{ pF}$
			10	ns min	$V_{S1} = V_{S2} = +10\text{ V}$ ; see Figure 31
Charge Injection	-20			pC typ	$V_S = 0\text{ V}$ , $R_S = 0\ \Omega$ , $C_L = 1\text{ nF}$ ; see Figure 33
Off Isolation	-80			dB typ	$R_L = 50\ \Omega$ , $C_L = 5\text{ pF}$ , $f = 100\text{ kHz}$ ; see Figure 26
Channel-to-Channel Crosstalk	-80			dB typ	$R_L = 50\ \Omega$ , $C_L = 5\text{ pF}$ , $f = 100\text{ kHz}$ ; see Figure 27
Total Harmonic Distortion + Noise	0.011			% typ	$R_L = 110\ \Omega$ , $15\text{ V p-p}$ , $f = 20\text{ Hz to } 20\text{ kHz}$ ; see Figure 29
-3 dB Bandwidth	110			MHz typ	$R_L = 50\ \Omega$ , $C_L = 5\text{ pF}$ ; see Figure 28
Insertion Loss	-0.18			dB typ	$R_L = 50\ \Omega$ , $C_L = 5\text{ pF}$ , $f = 1\text{ MHz}$ ; see Figure 28
$C_S$ (Off)	23			pF typ	$f = 1\text{ MHz}$ , $V_S = 0\text{ V}$
$C_D$ (Off)	50			pF typ	$f = 1\text{ MHz}$ , $V_S = 0\text{ V}$
$C_D$ , $C_S$ (On)	120			pF typ	$f = 1\text{ MHz}$ , $V_S = 0\text{ V}$
<b>POWER REQUIREMENTS</b>					
$I_{DD}$	0.001			$\mu\text{A}$ typ	$V_{DD} = +16.5\text{ V}$ , $V_{SS} = -16.5\text{ V}$
			1	$\mu\text{A}$ max	Digital Inputs = 0 V or $V_{DD}$
$I_{DD}$	170			$\mu\text{A}$ typ	Digital Input = 5 V
			285	$\mu\text{A}$ max	
$I_{SS}$	0.001			$\mu\text{A}$ typ	Digital Inputs = 0 V, 5 V, or $V_{DD}$
			1.0	$\mu\text{A}$ max	
$V_{DD}/V_{SS}$			$\pm 4.5/\pm 16.5$	V min/max	GND = 0 V

<sup>1</sup> Guaranteed by design, not subject to production test.

**12 V SINGLE SUPPLY**

$V_{DD} = 12\text{ V} \pm 10\%$ ,  $V_{SS} = 0\text{ V}$ ,  $GND = 0\text{ V}$ , unless otherwise noted.

**Table 2.**

Parameter	25°C	−40°C to +85°C	−40°C to +125°C	Unit	Test Conditions/Comments
<b>ANALOG SWITCH</b>					
Analog Signal Range			0 V to $V_{DD}$	V	
On Resistance ( $R_{ON}$ )	2.8 3.5	4.3	4.8	$\Omega$ typ $\Omega$ max	$V_S = 0\text{ V to }10\text{ V}$ , $I_S = -10\text{ mA}$ ; see Figure 23 $V_{DD} = +10.8\text{ V}$ , $V_{SS} = 0\text{ V}$
On-Resistance Match Between Channels ( $\Delta R_{ON}$ )	0.13			$\Omega$ typ	$V_S = 0\text{ V to }10\text{ V}$ , $I_S = -10\text{ mA}$
On-Resistance Flatness ( $R_{FLAT(ON)}$ )	0.21 0.6	0.23	0.25	$\Omega$ max $\Omega$ typ	$V_S = 0\text{ V to }10\text{ V}$ , $I_S = -10\text{ mA}$
	1.1	1.2	1.3	$\Omega$ max	
<b>LEAKAGE CURRENTS</b>					
Source Off Leakage, $I_S$ (Off)	$\pm 0.04$ $\pm 0.55$	$\pm 2$	$\pm 12.5$	nA typ nA max	$V_{DD} = 13.2\text{ V}$ , $V_{SS} = 0\text{ V}$ $V_S = 1\text{ V}/10\text{ V}$ , $V_D = 10\text{ V}/1\text{ V}$ ; see Figure 24
Drain Off Leakage, $I_D$ (Off)	$\pm 0.04$ $\pm 0.55$	$\pm 2$	$\pm 12.5$	nA typ nA max	$V_S = 1\text{ V}/10\text{ V}$ , $V_D = 10\text{ V}/1\text{ V}$ ; see Figure 24
Channel On Leakage, $I_D$ , $I_S$ (On)	$\pm 0.1$ $\pm 1$	$\pm 4$	$\pm 35$	nA typ nA max	$V_S = V_D = 1\text{ V or }10\text{ V}$ ; see Figure 25
<b>DIGITAL INPUTS</b>					
Input High Voltage, $V_{INH}$			2.0	V min	
Input Low Voltage, $V_{INL}$			0.8	V max	
Input Current, $I_{INL}$ or $I_{INH}$	0.001		$\pm 0.1$	$\mu\text{A}$ typ $\mu\text{A}$ max	$V_{IN} = V_{GND}$ or $V_{DD}$
Digital Input Capacitance, $C_{IN}$	3.5			pF typ	
<b>DYNAMIC CHARACTERISTICS<sup>1</sup></b>					
Transition Time, $t_{TRANSITION}$	200 270	320	350	ns typ ns max	$R_L = 300\ \Omega$ , $C_L = 35\text{ pF}$ $V_S = 8\text{ V}$ ; see Figure 30
$t_{ON}$ (EN)	175 235	280	310	ns typ ns max	$R_L = 300\ \Omega$ , $C_L = 35\text{ pF}$ $V_S = 8\text{ V}$ ; see Figure 30
$t_{OFF}$ (EN)	105 145	175	195	ns typ ns max	$R_L = 300\ \Omega$ , $C_L = 35\text{ pF}$ $V_S = 8\text{ V}$ ; see Figure 30
Break-Before-Make Time Delay, $t_{BBM}$	70		10	ns typ ns min	$R_L = 300\ \Omega$ , $C_L = 35\text{ pF}$ $V_{S1} = V_{S2} = 8\text{ V}$ ; see Figure 31
Charge Injection	30			pC typ	$V_S = 6\text{ V}$ , $R_S = 0\ \Omega$ , $C_L = 1\text{ nF}$ ; see Figure 33
Off Isolation	−80			dB typ	$R_L = 50\ \Omega$ , $C_L = 5\text{ pF}$ , $f = 100\text{ kHz}$ ; see Figure 26;
Channel-to-Channel Crosstalk	−80			dB typ	$R_L = 50\ \Omega$ , $C_L = 5\text{ pF}$ , $f = 100\text{ kHz}$ ; see Figure 27
−3 dB Bandwidth	78			MHz typ	$R_L = 50\ \Omega$ , $C_L = 5\text{ pF}$ ; see Figure 28
Insertion Loss	−0.3			dB typ	$R_L = 50\ \Omega$ , $C_L = 5\text{ pF}$ , $f = 1\text{ MHz}$ ; see Figure 28
$C_S$ (Off)	40			pF typ	$f = 1\text{ MHz}$ , $V_S = 6\text{ V}$
$C_D$ (Off)	80			pF typ	$f = 1\text{ MHz}$ , $V_S = 6\text{ V}$
$C_D$ , $C_S$ (On)	140			pF typ	$f = 1\text{ MHz}$ , $V_S = 6\text{ V}$
<b>POWER REQUIREMENTS</b>					
$I_{DD}$	0.001		1.0	$\mu\text{A}$ typ $\mu\text{A}$ max	$V_{DD} = 13.2\text{ V}$ Digital inputs = 0 V or $V_{DD}$
$I_{DD}$	170		285	$\mu\text{A}$ typ $\mu\text{A}$ max	Digital inputs = 5 V
$V_{DD}$			5/16.5	V min/max	$GND = 0\text{ V}$ , $V_{SS} = 0\text{ V}$

<sup>1</sup> Guaranteed by design, not subject to production test.

**5 V DUAL SUPPLY**

$V_{DD} = 5\text{ V} \pm 10\%$ ,  $V_{SS} = -5\text{ V} \pm 10\%$ ,  $GND = 0\text{ V}$ , unless otherwise noted.

**Table 3.**

Parameter	25°C	-40°C to +85°C	-40°C to +125°C	Unit	Test Conditions/Comments
<b>ANALOG SWITCH</b>					
Analog Signal Range			$V_{DD}$ to $V_{SS}$	V	
On Resistance ( $R_{ON}$ )	3.3 4	4.9	5.4	$\Omega$ typ $\Omega$ max	$V_S = \pm 4.5\text{ V}$ , $I_S = -10\text{ mA}$ ; see Figure 23 $V_{DD} = +4.5\text{ V}$ , $V_{SS} = -4.5\text{ V}$
On-Resistance Match Between Channels ( $\Delta R_{ON}$ )	0.13			$\Omega$ typ	$V_S = \pm 4.5\text{ V}$ , $I_S = -10\text{ mA}$
On-Resistance Flatness ( $R_{FLAT(ON)}$ )	0.22	0.23	0.25	$\Omega$ max	$V_S = \pm 4.5\text{ V}$ , $I_S = -10\text{ mA}$
	0.9			$\Omega$ typ	
	1.1	1.24	1.31	$\Omega$ max	
<b>LEAKAGE CURRENTS</b>					
Source Off Leakage, $I_S$ (Off)	$\pm 0.03$			nA typ	$V_{DD} = +5.5\text{ V}$ , $V_{SS} = -5.5\text{ V}$ $V_S = \pm 4.5\text{ V}$ , $V_D = \mp 4.5\text{ V}$ ; see Figure 24
	$\pm 0.2$	$\pm 1$	$\pm 12.5$	nA max	
Drain Off Leakage, $I_D$ (Off)	$\pm 0.03$			nA typ	$V_S = \pm 4.5\text{ V}$ , $V_D = \mp 4.5\text{ V}$ ; see Figure 24
	$\pm 0.2$	$\pm 1$	$\pm 12.5$	nA max	
Channel On Leakage, $I_D$ , $I_S$ (On)	$\pm 0.05$ $\pm 0.25$	$\pm 1$ $\pm 1.5$	$\pm 12.5$ $\pm 35$	nA typ nA max	$V_S = V_D = \pm 4.5\text{ V}$ ; see Figure 25
<b>DIGITAL INPUTS</b>					
Input High Voltage, $V_{INH}$			2.0	V min	
Input Low Voltage, $V_{INL}$			0.8	V max	
Input Current, $I_{INL}$ or $I_{INH}$	0.001			$\mu\text{A}$ typ $\mu\text{A}$ max	$V_{IN} = V_{GND}$ or $V_{DD}$
			$\pm 0.1$	$\mu\text{A}$ max	
Digital Input Capacitance, $C_{IN}$	3.5			pF typ	
<b>DYNAMIC CHARACTERISTICS<sup>1</sup></b>					
Transition Time, $t_{TRANSITION}$	310 445	510	565	ns typ ns max	$R_L = 300\ \Omega$ , $C_L = 35\text{ pF}$ $V_S = 3\text{ V}$ ; see Figure 30
$t_{ON}$ (EN)	255 355	415	460	ns typ ns max	$R_L = 300\ \Omega$ , $C_L = 35\text{ pF}$ $V_S = 3\text{ V}$ ; see Figure 30
$t_{OFF}$ (EN)	215 305	355	400	ns typ ns max	$R_L = 300\ \Omega$ , $C_L = 35\text{ pF}$ $V_S = 3\text{ V}$ ; see Figure 30
Break-Before-Make Time Delay, $t_{BBM}$	80		10	ns typ ns min	$R_L = 300\ \Omega$ , $C_L = 35\text{ pF}$ $V_{S1} = V_{S2} = 3\text{ V}$ ; see Figure 31
Charge Injection	30			pC typ	$V_S = 0\text{ V}$ , $R_S = 0\ \Omega$ , $C_L = 1\text{ nF}$ ; see Figure 33
Off Isolation	-80			dB typ	$R_L = 50\ \Omega$ , $C_L = 5\text{ pF}$ , $f = 100\text{ kHz}$ ; see Figure 26
Channel-to-Channel Crosstalk	-80			dB typ	$R_L = 50\ \Omega$ , $C_L = 5\text{ pF}$ , $f = 100\text{ kHz}$ ; see Figure 27
Total Harmonic Distortion + Noise	0.03			% typ	$R_L = 110\ \Omega$ , 2.5 V pp, $f = 20\text{ Hz}$ to 20 kHz; see Figure 29
-3 dB Bandwidth	85			MHz typ	$R_L = 50\ \Omega$ , $C_L = 5\text{ pF}$ ; see Figure 28
Insertion Loss	-0.28			dB typ	$R_L = 50\ \Omega$ , $C_L = 5\text{ pF}$ , $f = 1\text{ MHz}$ ; see Figure 28
$C_S$ (Off)	33			pF typ	$V_S = 0\text{ V}$ , $f = 1\text{ MHz}$
$C_D$ (Off)	65			pF typ	$V_S = 0\text{ V}$ , $f = 1\text{ MHz}$
$C_D$ , $C_S$ (On)	145			pF typ	$V_S = 0\text{ V}$ , $f = 1\text{ MHz}$
<b>POWER REQUIREMENTS</b>					
$I_{DD}$	0.001			$\mu\text{A}$ typ	$V_{DD} = +5.5\text{ V}$ , $V_{SS} = -5.5\text{ V}$ Digital inputs = 0 V or $V_{DD}$
			1.0	$\mu\text{A}$ max	
$I_{SS}$	0.001			$\mu\text{A}$ typ	Digital inputs = 0 V or $V_{DD}$
			1.0	$\mu\text{A}$ max	
$V_{DD}/V_{SS}$			$\pm 4.5/\pm 16.5$	V min/max	$GND = 0\text{ V}$

<sup>1</sup> Guaranteed by design, not subject to production test.

**CONTINUOUS CURRENT PER CHANNEL**

Table 4.

Parameter	25°C	85°C	125°C	Unit	Test Conditions/Comments
CONTINUOUS CURRENT PER CHANNEL <sup>1</sup>					
15 V Dual Supply					$V_{DD} = +13.5\text{ V}, V_{SS} = -13.5\text{ V}$
ADG1436 TSSOP	260	170	100	mA max	
ADG1436 LFCSP	400	250	120	mA max	
12 V Single Supply					$V_{DD} = 10.8\text{ V}, V_{SS} = 0\text{ V}$
ADG1436 TSSOP	240	160	100	mA max	
ADG1436 LFCSP	350	240	120	mA max	
5 V Dual Supply					$V_{DD} = +4.5\text{ V}, V_{SS} = -4.5\text{ V}$
ADG1436 TSSOP	240	160	100	mA max	
ADG1436 LFCSP	300	240	120	mA max	

<sup>1</sup> Guaranteed by design, not subject to production test.

## ABSOLUTE MAXIMUM RATINGS

$T_A = 25^\circ\text{C}$ , unless otherwise noted.

Table 5.

Parameter	Ratings
$V_{DD}$ to $V_{SS}$	35 V
$V_{DD}$ to GND	-0.3 V to +25 V
$V_{SS}$ to GND	+0.3 V to -25 V
Analog Inputs <sup>1</sup>	$V_{SS} - 0.3\text{ V}$ to $V_{DD} + 0.3\text{ V}$ or 30 mA, whichever occurs first
Digital Inputs <sup>1</sup>	GND - 0.3 V to $V_{DD} + 0.3\text{ V}$ or 30 mA, whichever occurs first
Peak Current, S or D	600 mA (pulsed at 1 ms, 10% duty cycle maximum)
Continuous Current per Channel, S or D <sup>2</sup>	Data + 15%
Operating Temperature Range Automotive (Y Version)	-40°C to +125°C
Storage Temperature Range	-65°C to +150°C
Junction Temperature	150°C
16-Lead TSSOP, $\theta_{JA}$ Thermal Impedance (4-Layer Board)	112°C/W
16-Lead LFCSP, $\theta_{JA}$ Thermal Impedance	30.4°C/W
Reflow Soldering Peak Temperature, Pb Free	260(+0/-5)°C

<sup>1</sup> Over voltages at IN, S, and D are clamped by internal diodes. Current must be limited to the maximum ratings given.

<sup>2</sup> See data given in Table 4.

Stresses at or above those listed under Absolute Maximum Ratings may cause permanent damage to the product. This is a stress rating only; functional operation of the product at these or any other conditions above those indicated in the operational section of this specification is not implied. Operation beyond the maximum operating conditions for extended periods may affect product reliability.

### ESD CAUTION



**ESD (electrostatic discharge) sensitive device.** Charged devices and circuit boards can discharge without detection. Although this product features patented or proprietary protection circuitry, damage may occur on devices subjected to high energy ESD. Therefore, proper ESD precautions should be taken to avoid performance degradation or loss of functionality.

# PIN CONFIGURATIONS AND FUNCTION DESCRIPTIONS

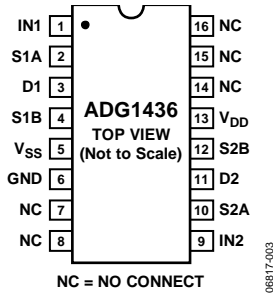
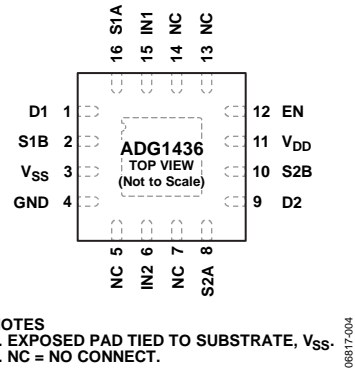

Figure 3. TSSOP Pin Configuration



NOTES  
 1. EXPOSED PAD TIED TO SUBSTRATE, V<sub>SS</sub>.  
 2. NC = NO CONNECT.

Figure 4. LFCSP Pin Configuration

Table 6. Pin Function Descriptions

Pin No.		Mnemonic	Function
TSSOP	LFCSP		
1	15	IN1	Logic Control Input.
2	16	S1A	Source Terminal. Can be an input or output.
3	1	D1	Drain Terminal. Can be an input or output.
4	2	S1B	Source Terminal. Can be an input or output.
5	3	V <sub>SS</sub>	Most Negative Power Supply Potential.
6	4	GND	Ground (0 V) Reference.
7, 8, 14 to 16	5, 7, 13, 14	NC	No Connect.
9	6	IN2	Logic Control Input.
10	8	S2A	Source Terminal. Can be an input or output.
11	9	D2	Drain Terminal. Can be an input or output.
12	10	S2B	Source Terminal. Can be an input or output.
13	11	V <sub>DD</sub>	Most Positive Power Supply Potential.
N/A	12	EN	Active High Digital Input. When this pin is low, the device is disabled and all switches are off. When this pin is high, IN <sub>x</sub> logic inputs determine the on switches.

## TRUTH TABLE FOR SWITCHES

Table 7. ADG1436 TSSOP Truth Table

IN <sub>x</sub>	S <sub>x</sub> A	S <sub>x</sub> B
0	Off	On
1	On	Off

Table 8. ADG1436 LFCSP Truth Table

EN	IN <sub>x</sub>	S <sub>x</sub> A	S <sub>x</sub> B
0	X	Off	Off
1	0	Off	On
1	1	On	Off

TYPICAL PERFORMANCE CHARACTERISTICS

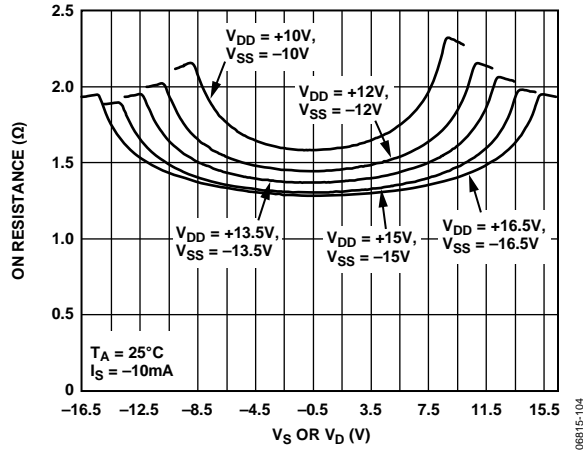

Figure 5. On Resistance vs.  $V_D$  or  $V_S$ , Dual Supply

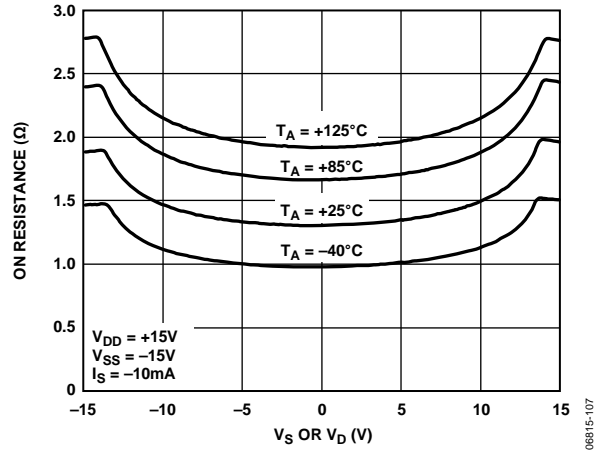

Figure 8. On Resistance vs.  $V_D$  or  $V_S$  for Different Temperatures, 15 V Dual Supply

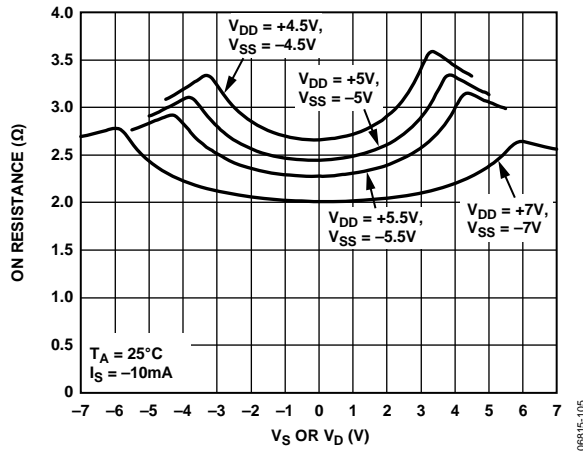

Figure 6. On Resistance vs.  $V_D$  or  $V_S$ , Dual Supply

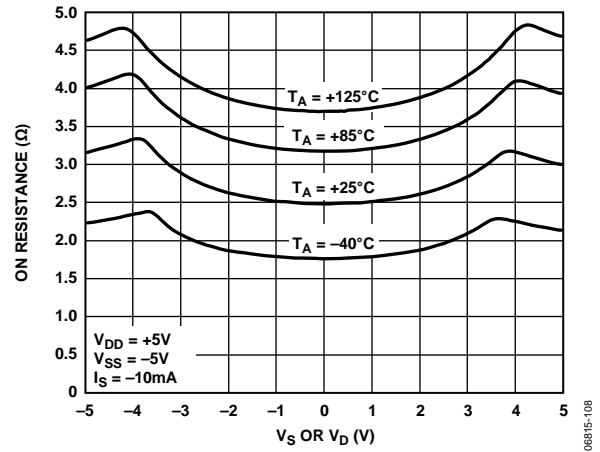

Figure 9. On Resistance vs.  $V_D$  or  $V_S$  for Different Temperatures, 5 V Dual Supply

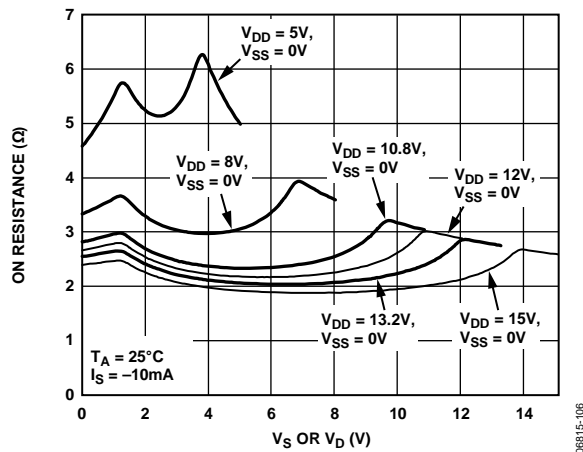

Figure 7. On Resistance vs.  $V_D$  or  $V_S$ , Single Supply

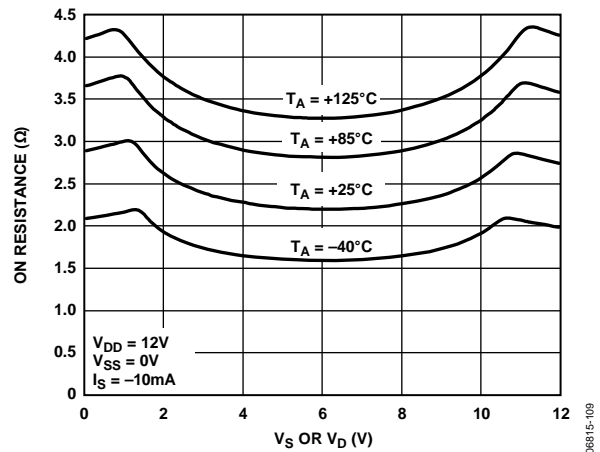

Figure 10. On Resistance vs.  $V_D$  or  $V_S$  for Different Temperatures, Single Supply

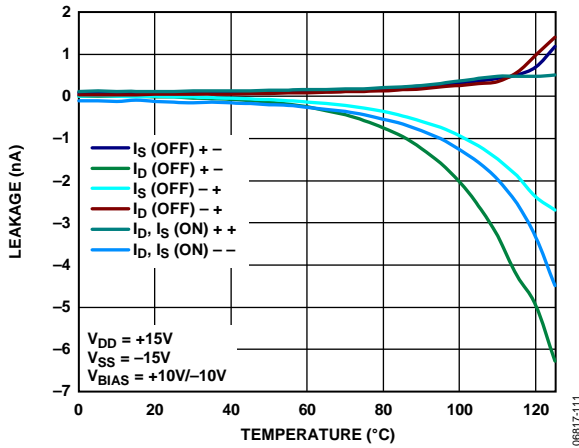

Figure 11. Leakage Currents vs. Temperature, 15 V Dual Supply

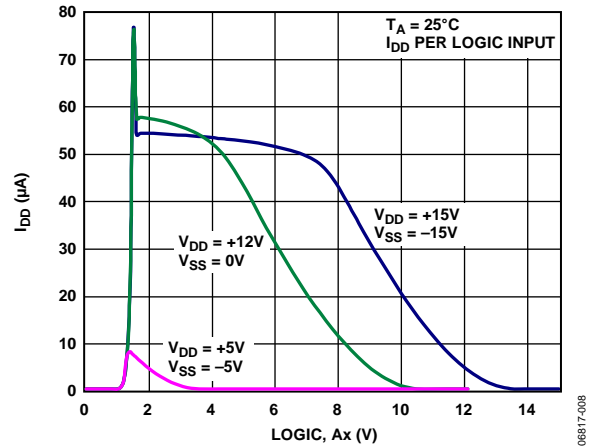

Figure 14.  $I_{DD}$  vs. Logic Level

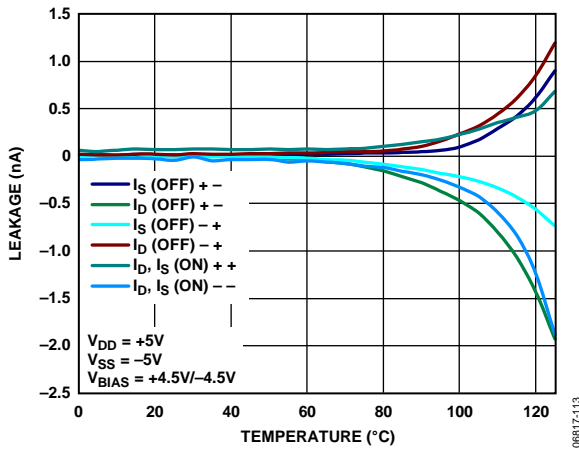

Figure 12. Leakage Currents vs. Temperature, 5 V Dual Supply

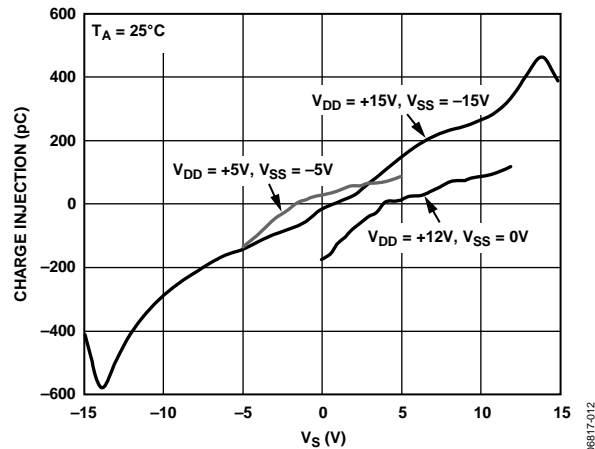

Figure 15. Charge Injection vs. Source Voltage

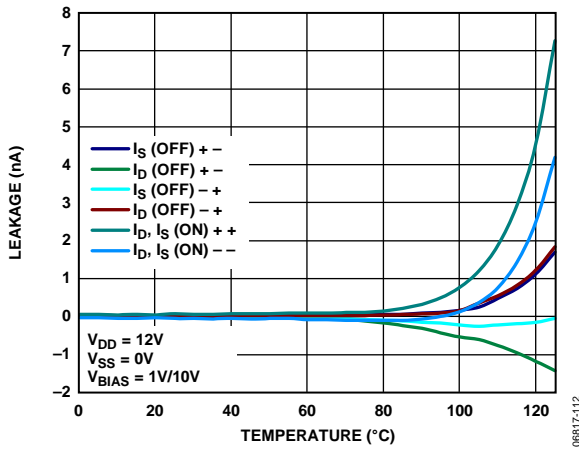

Figure 13. Leakage Currents vs. Temperature, 12 V Single Supply

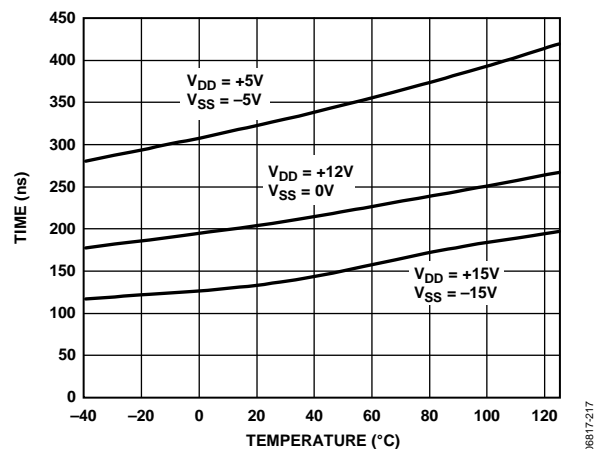

Figure 16.  $t_{TRANSITION}$  Time vs. Temperature

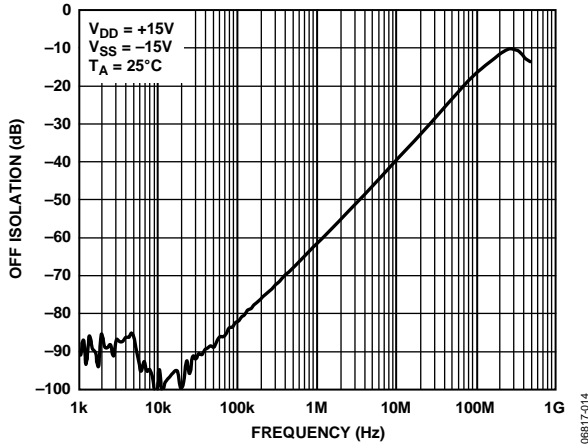

Figure 17. Off Isolation vs. Frequency

06817-014

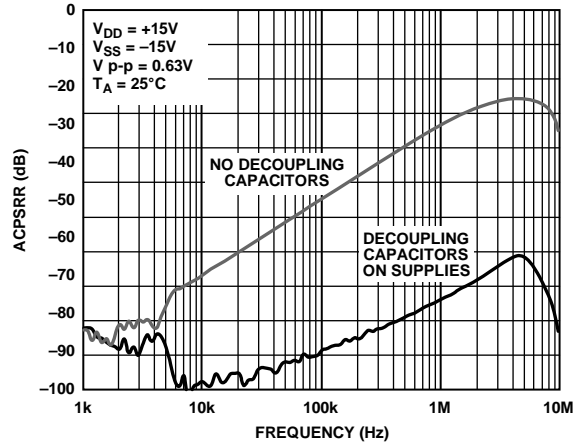

Figure 20. ACPSRR vs. Frequency

06817-017

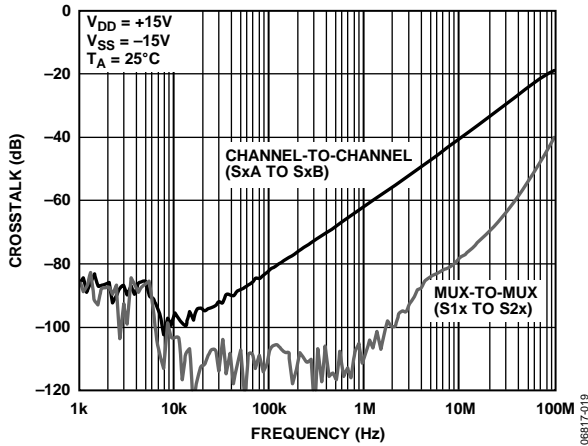

Figure 18. Crosstalk vs. Frequency

06817-019

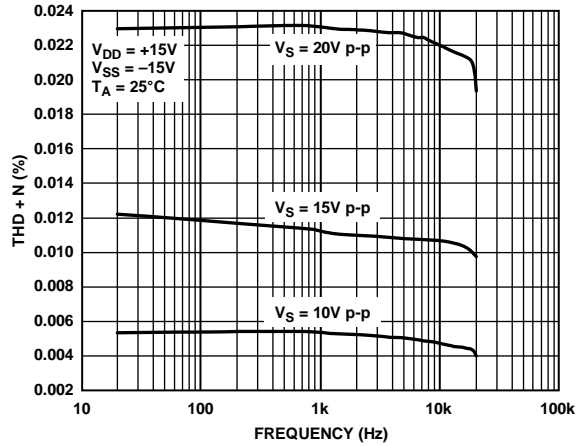

Figure 21. THD + N vs. Frequency, 15 V Dual Supply

06817-117

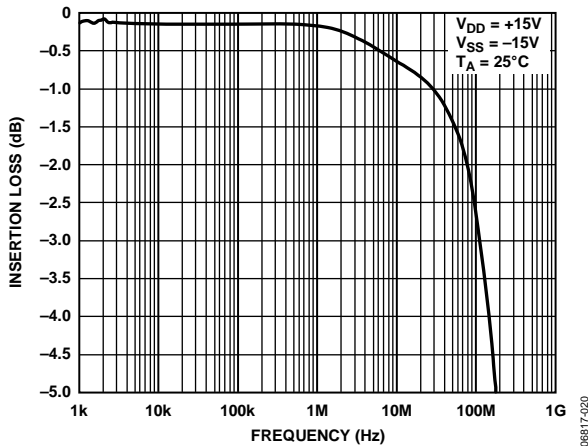

Figure 19. On Response vs. Frequency

06817-020

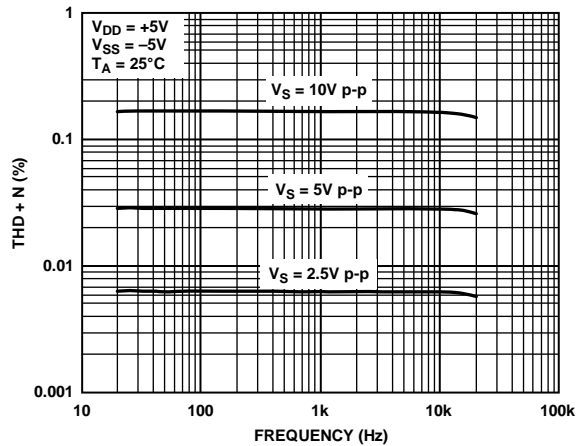

Figure 22. THD + N vs. Frequency, 5 V Dual Supply

06817-118

## TERMINOLOGY

**I<sub>DD</sub>**

The positive supply current.

**I<sub>SS</sub>**

The negative supply current.

**V<sub>D</sub>, V<sub>S</sub>**

The analog voltage on Terminal D and Terminal S.

**R<sub>ON</sub>**

The ohmic resistance between Terminal D and Terminal S.

**R<sub>FLAT(ON)</sub>**

Flatness that is defined as the difference between the maximum and minimum value of on resistance measured over the specified analog signal range.

**I<sub>S</sub> (Off)**

The source leakage current with the switch off.

**I<sub>D</sub> (Off)**

The drain leakage current with the switch off.

**I<sub>D</sub>, I<sub>S</sub> (On)**

The channel leakage current with the switch on.

**V<sub>INL</sub>**

The maximum input voltage for Logic 0.

**V<sub>INH</sub>**

The minimum input voltage for Logic 1.

**I<sub>INL</sub>, I<sub>INH</sub>**

The input current of the digital input.

**C<sub>S</sub> (Off)**

The off-switch source capacitance, which is measured with reference to ground.

**C<sub>D</sub> (Off)**

The off-switch drain capacitance, which is measured with reference to ground.

**C<sub>D</sub>, C<sub>S</sub> (On)**

The on-switch capacitance, which is measured with reference to ground.

**C<sub>IN</sub>**

The digital input capacitance.

**t<sub>TRANSITION</sub>**

The delay time between the 50% and 90% points of the digital input and switch on condition when switching from one address state to another.

**Charge Injection**

A measure of the glitch impulse transferred from the digital input to the analog output during switching.

**Off Isolation**

A measure of unwanted signal coupling through an off switch.

**Crosstalk**

A measure of unwanted signal that is coupled through from one channel to another as a result of parasitic capacitance.

**Bandwidth**

The frequency at which the output is attenuated by 3 dB.

**On Response**

The frequency response of the on switch.

**Insertion Loss**

The loss due to the on resistance of the switch.

**THD + N**

The ratio of the harmonic amplitude plus noise of the signal to the fundamental.

TEST CIRCUITS

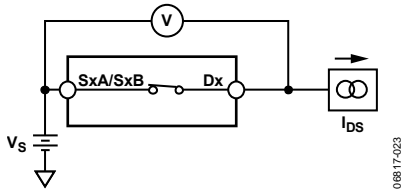

Figure 23. On Resistance

06817-023

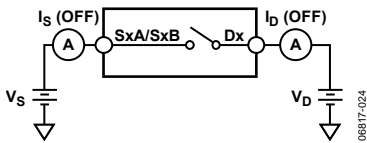

Figure 24. Off Leakage

06817-024

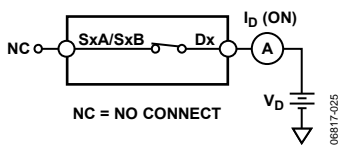
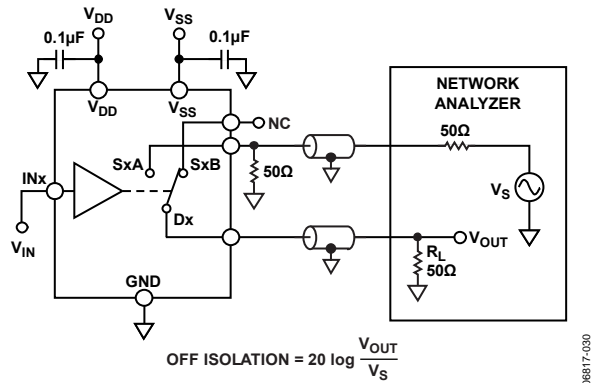

Figure 25. On Leakage

06817-025



$$\text{OFF ISOLATION} = 20 \log \frac{V_{\text{OUT}}}{V_{\text{S}}}$$

Figure 26. Off Isolation

06817-030

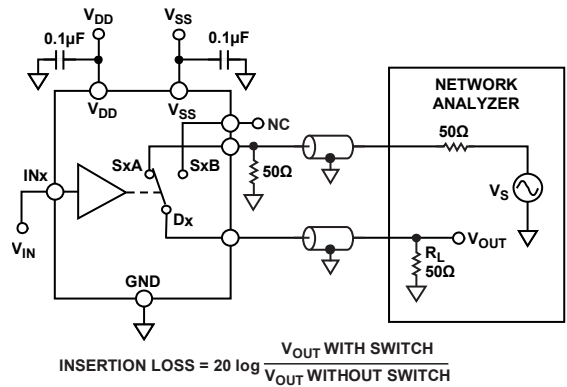

$$\text{INSERTION LOSS} = 20 \log \frac{V_{\text{OUT WITH SWITCH}}}{V_{\text{OUT WITHOUT SWITCH}}}$$

Figure 27. Channel-to-Channel Crosstalk

06817-031

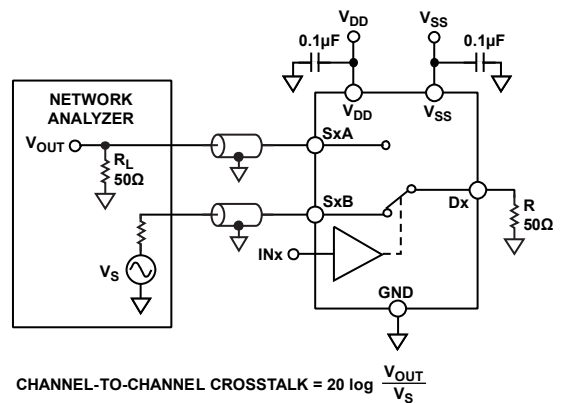

$$\text{CHANNEL-TO-CHANNEL CROSSTALK} = 20 \log \frac{V_{\text{OUT}}}{V_{\text{S}}}$$

Figure 28. Bandwidth

06817-032

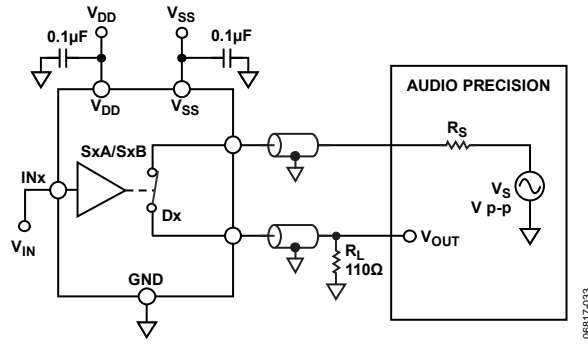

Figure 29. THD + Noise

06817-033

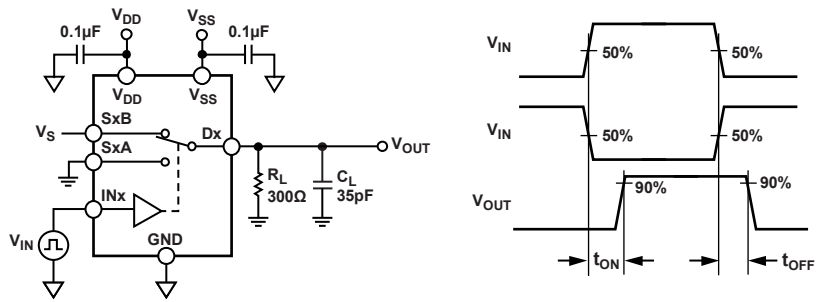

Figure 30. Switching Times

06817-026

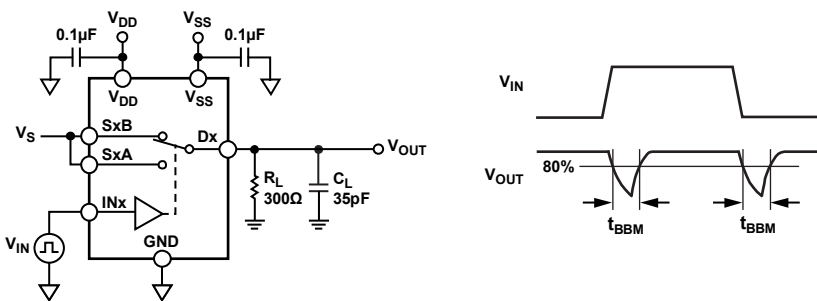

Figure 31. Break-Before-Make Time Delay

06817-027

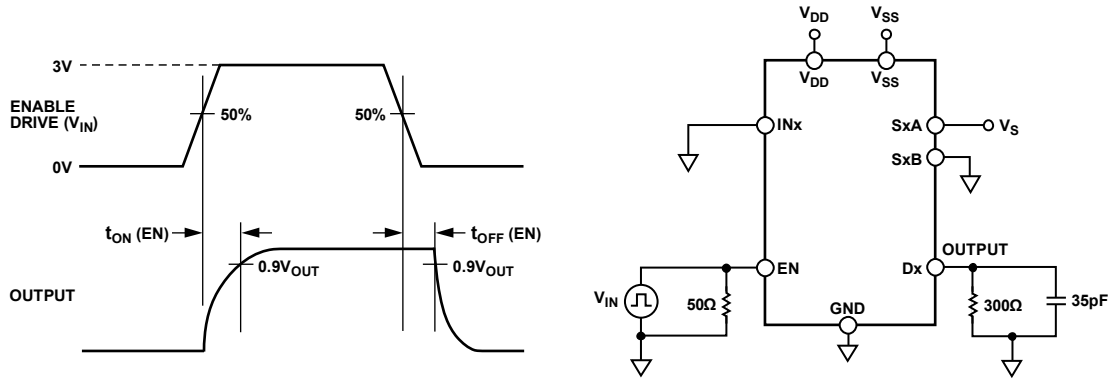

Figure 32. Enable Delay,  $t_{ON}(EN)$ ,  $t_{OFF}(EN)$

06817-028

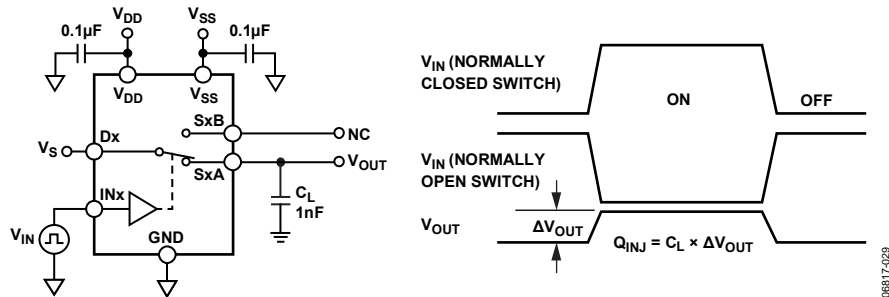
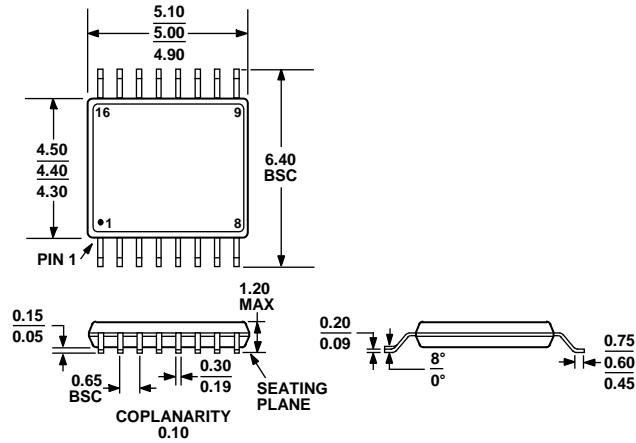

Figure 33. Charge Injection

06817-029

OUTLINE DIMENSIONS



COMPLIANT TO JEDEC STANDARDS MO-153-AB

Figure 34. 16-Lead Thin Shrink Small Outline Package [TSSOP] (RU-16)

Dimensions shown in millimeters

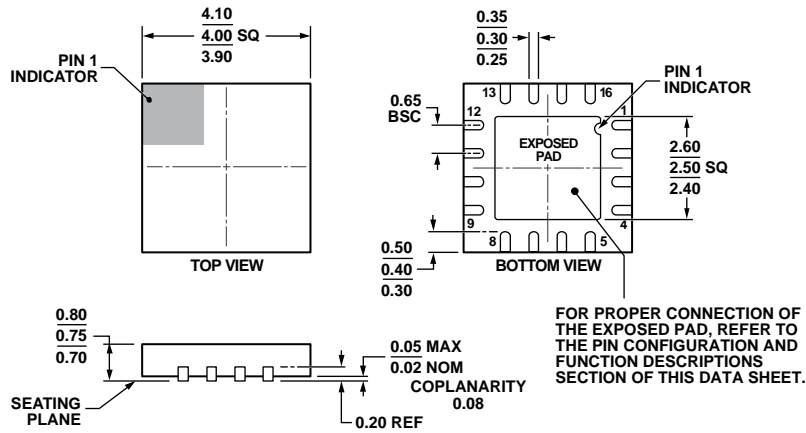

COMPLIANT TO JEDEC STANDARDS MO-220-WGGC.

Figure 35. 16-Lead Lead Frame Chip Scale Package [LFCSP] 4 mm x 4 mm Body and 0.75 mm Package Height (CP-16-26)

Dimensions shown in millimeters

ORDERING GUIDE

Model <sup>1</sup>	Temperature Range	Package Description	Package Option
ADG1436YRUZ	-40°C to +125°C	16-Lead Thin Shrink Small Outline Package [TSSOP]	RU-16
ADG1436YRUZ-REEL7	-40°C to +125°C	16-Lead Thin Shrink Small Outline Package [TSSOP]	RU-16
ADG1436YCPZ-REEL	-40°C to +125°C	16-Lead Lead Frame Chip Scale Package [LFCSP]	CP-16-26
ADG1436YCPZ-REEL7	-40°C to +125°C	16-Lead Lead Frame Chip Scale Package [LFCSP]	CP-16-26

<sup>1</sup> Z = RoHS Compliant Part.

## Looking for pricing, stock, or lifecycle information?

Click below to explore more details on WIN SOURCE:

 [View ADG1436YRUZ on WIN SOURCE](#)

 [Analog Devices Inc. Information](#)

## Optimize Your Supply Chain with WIN SOURCE Solutions

-  Global Sourcing Solution
-  Obsolete Management
-  Cost Control Management
-  Shortage Management
-  Alternative Solution
-  Excess Inventory Management