



**THE DATASHEET OF
ADG738BRUZ**



FEATURES

3-wire serial interface
 2.7 V to 5.5 V single supply
 2.5 Ω on resistance
 0.75 Ω on-resistance flatness
 100 pA leakage currents
 Single 8-to-1 multiplexer **ADG738**
 Dual 4-to-1 multiplexer **ADG739**
 Power-on reset
 TTL/CMOS-compatible
 Qualified for automotive applications

APPLICATIONS

Data acquisition systems
 Communication systems
 Relay replacement
 Audio and video switching

GENERAL DESCRIPTION

The **ADG738** and **ADG739** are CMOS analog matrix switches with a serially-controlled 3-wire interface. The **ADG738** is an 8-channel matrix switch, while the **ADG739** is a dual 4-channel matrix switch. On resistance is closely matched between switches and very flat over the full signal range.

The **ADG738** and **ADG739** utilize a 3-wire serial interface that is compatible with SPI™, QSPI™, MICROWIRE®, and some DSP interface standards. The output of the input shift register, DOUT, enables a number of these parts to be daisy-chained. On power-up, the internal input shift register contains all zeros and all switches are in the off state.

Each switch conducts equally well in both directions when on, making these parts suitable for both multiplexing and demultiplexing applications. As each switch is turned on or off by a separate bit, these parts can also be configured as a type of switch array, where any, all, or none of the eight switches may be closed at any time. The input signal range extends to the supply rails.

Rev. A

[Document Feedback](#)

Information furnished by Analog Devices is believed to be accurate and reliable. However, no responsibility is assumed by Analog Devices for its use, nor for any infringements of patents or other rights of third parties that may result from its use. Specifications subject to change without notice. No license is granted by implication or otherwise under any patent or patent rights of Analog Devices. Trademarks and registered trademarks are the property of their respective owners.

FUNCTIONAL BLOCK DIAGRAMS

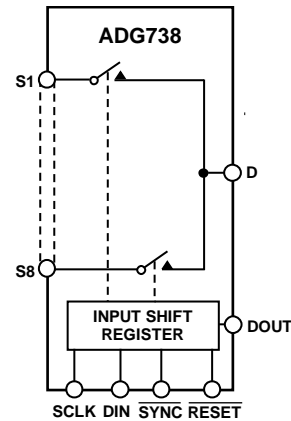

Figure 1.

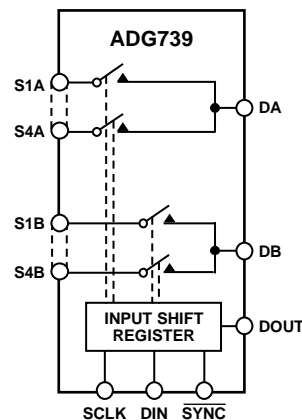

Figure 2.

All channels exhibit break-before-make switching action, preventing momentary shorting when switching channels.

The **ADG738** and **ADG739** are available in 16-lead TSSOP packages.

PRODUCT HIGHLIGHTS

- 3-Wire Serial Interface.
- Single Supply Operation. The **ADG738/ADG739** are fully specified and guaranteed with 3 V and 5 V supply rails.
- Low On Resistance, 2.5 Ω typical.
- Any configuration of switches may be on or off at any one time.
- Guaranteed Break-Before-Make Switching Action.
- Small 16-lead TSSOP Package.

TABLE OF CONTENTS

Features	1	Theory of Operation	15
Applications.....	1	Power-On Reset.....	15
General Description	1	Serial Interface	15
Functional Block Diagrams.....	1	Microprocessor Interfacing.....	15
Product Highlights	1	ADSP-21xx to ADG738/ADG739	15
Revision History	2	8051 Interface to ADG738/ADG739.....	16
Specifications.....	3	MC68HC11 Interface to ADG738/ADG739.....	16
Timing Characteristics	5	Applications Information	17
Absolute Maximum Ratings.....	6	Expand the Number of Selectable Serial Devices Using an	
ESD Caution.....	6	ADG739.....	17
Pin Configurations and Function Descriptions	7	Daisy-Chaining Multiple ADG738s	17
Typical Performance Characteristics	9	Outline Dimensions	18
Test Circuits.....	12	Ordering Guide	18
Terminology	14	Automotive Products.....	18

REVISION HISTORY

11/12—Rev. 0 to Rev. A

Updated Format.....	Universal
Changes to Features Section.....	1
Added W Version Specifications to Table 1	3
Added W Version Specifications to Table 2	4
Changes to Table 4.....	6
Changes to Figure 7, Figure 8, and Figure 11	9
Changes to Figure 12.....	10
Deleted Figure 22.....	12
Updated Outline Dimensions	19
Changes to Ordering Guide	19

4/00—Revision 0: Initial Version

SPECIFICATIONS

$V_{DD} = 5\text{ V} \pm 10\%$, GND = 0 V, unless otherwise noted.

Table 1.

Parameter	25°C	B Version –40°C to +85°C	W Version –40°C to +105°C	Unit	Test Conditions/Comments
ANALOG SWITCH					
Analog Signal Range			0 V to V_{DD}	V	
On Resistance (R_{ON})	2.5 4.5	5	6	Ω typ Ω max	$V_S = 0\text{ V to }V_{DD}$, $I_S = 10\text{ mA}$; see Figure 19
On-Resistance Match Between Channels (ΔR_{ON})		0.4		Ω typ	$V_S = 0\text{ V to }V_{DD}$, $I_S = 10\text{ mA}$
On-Resistance Flatness ($R_{FLAT(ON)}$)	0.75	0.8	1	Ω max Ω typ	$V_S = 0\text{ V to }V_{DD}$, $I_S = 10\text{ mA}$
		1.2	1.5	Ω max	
LEAKAGE CURRENTS					
Source Off Leakage I_S (Off)	± 0.01 ± 0.1	± 0.3	± 0.6	nA typ nA max	$V_{DD} = 5.5\text{ V}$ $V_D = 4.5\text{ V}/1\text{ V}$, $V_S = 1\text{ V}/4.5\text{ V}$; see Figure 20
Drain Off Leakage I_D (Off)	± 0.01 ± 0.1	± 1	± 1.3	nA typ nA max	$V_D = 4.5\text{ V}/1\text{ V}$, $V_S = 1\text{ V}/4.5\text{ V}$
Channel On Leakage I_D , I_S (On)	± 0.01 ± 0.1	± 1	± 1.3	nA typ nA max	$V_D = V_S = 1\text{ V}/4.5\text{ V}$, see Figure 21
DIGITAL INPUTS					
Input High Voltage, V_{INH}			2.4	V min	
Input Low Voltage, V_{INL}			0.8	V max	
Input Current, I_{INL} or I_{INH}	0.005	± 0.1	± 0.1	μA typ μA max	$V_{IN} = V_{INL}$ or V_{INH}
C_{IN} , Digital Input Capacitance	3			pF typ	
DIGITAL OUTPUT					
Output Low Voltage		0.4		max	$I_{SINK} = 6\text{ mA}$
C_{OUT} , Digital Output Capacitance	4			pF typ	
DYNAMIC CHARACTERISTICS¹					
t_{ON}	20	32	35	ns typ ns max	$R_L = 300\ \Omega$, $C_L = 35\text{ pF}$, see Figure 22; $V_{S1} = 3\text{ V}$
t_{OFF}	10	17	20	ns typ ns max	$R_L = 300\ \Omega$, $C_L = 35\text{ pF}$, see Figure 22; $V_{S1} = 3\text{ V}$
Break-Before-Make Time Delay, t_D	9	1	1	ns typ ns min	$R_L = 300\ \Omega$, $C_L = 35\text{ pF}$; $V_{S1} = V_{S8} = 3\text{ V}$, see Figure 22
Charge Injection	± 3			pC typ	$V_S = 2.5\text{ V}$, $R_S = 0\ \Omega$, $C_L = 1\text{ nF}$; see Figure 23
Off Isolation	–55 –75			dB typ dB typ	$R_L = 50\ \Omega$, $C_L = 5\text{ pF}$, $f = 10\text{ MHz}$
Channel-to-Channel Crosstalk	–55 –75			dB typ dB typ	$R_L = 50\ \Omega$, $C_L = 5\text{ pF}$, $f = 10\text{ MHz}$
–3 dB Bandwidth				dB typ	$R_L = 50\ \Omega$, $C_L = 5\text{ pF}$, $f = 1\text{ MHz}$; see Figure 24
ADG738	65			MHz typ	$R_L = 50\ \Omega$, $C_L = 5\text{ pF}$, see Figure 25
ADG739	100			MHz typ	
C_S (Off)	13			pF typ	
C_D (Off)				pF typ	
ADG738	85			pF typ	
ADG739	42			pF typ	
C_D , C_S (On)				pF typ	
ADG738	96			pF typ	
ADG739	48			pF typ	
POWER REQUIREMENTS					
I_{DD}	10	20	20	μA typ μA max	$V_{DD} = 5.5\text{ V}$ Digital Inputs = 0 V or 5.5 V

¹ Guaranteed by design, not subject to production test.

$V_{DD} = 3\text{ V} \pm 10\%$, $GND = 0\text{ V}$, unless otherwise noted.

Table 2.

Parameter	25°C	B Version –40°C to +85°C	W Version –40°C to +105°C	Unit	Test Conditions/Comments
ANALOG SWITCH					
Analog Signal Range			0 V to V_{DD}	V	
On Resistance (R_{ON})	6 11	12	16	Ω typ Ω max	$V_S = 0\text{ V to }V_{DD}$, $I_S = 10\text{ mA}$; see Figure 19
On-Resistance Match Between Channels (ΔR_{ON})		0.4		Ω typ	$V_S = 0\text{ V to }V_{DD}$, $I_S = 10\text{ mA}$
On-Resistance Flatness ($R_{FLAT(ON)}$)	3.5	1.2	1.4	Ω max Ω typ	$V_S = 0\text{ V to }V_{DD}$, $I_S = 10\text{ mA}$
LEAKAGE CURRENTS					
Source Off Leakage I_S (Off)	± 0.01 ± 0.1	± 0.3	± 0.6	nA typ nA max	$V_{DD} = 3.3\text{ V}$ $V_S = 3\text{ V}/1\text{ V}$, $V_D = 1\text{ V}/3\text{ V}$; see Figure 20
Drain Off Leakage I_D (Off)	± 0.01 ± 0.1	± 1	± 1.3	nA typ nA max	$V_D = 3\text{ V}/1\text{ V}$, $V_D = 1\text{ V}/3\text{ V}$
Channel On Leakage I_D , I_S (On)	± 0.01 ± 0.1	± 1	± 1.3	nA typ nA max	$V_D = V_S = 3\text{ V}/1\text{ V}$, see Figure 21
DIGITAL INPUTS					
Input High Voltage, V_{INH}			2.0	V min	
Input Low Voltage, V_{INL}			0.4	V max	
Input Current, I_{INL} or I_{INH}	0.005	± 0.1	± 0.1	μA typ μA max	$V_{IN} = V_{INL}$ or V_{INH}
C_{IN} , Digital Input Capacitance	3			pF typ	
DIGITAL OUTPUT					
Output Low Voltage		0.4		max	$I_{SINK} = 6\text{ mA}$
C_{OUT} , Digital Output Capacitance	4			pF typ	
DYNAMIC CHARACTERISTICS¹					
t_{ON}	40	70	75	ns typ ns max	$R_L = 300\ \Omega$, $C_L = 35\text{ pF}$, see Figure 22; $V_{S1} = 2\text{ V}$
t_{OFF}	14	25	40	ns typ ns max	$R_L = 300\ \Omega$, $C_L = 35\text{ pF}$, see Figure 22; $V_{S1} = 2\text{ V}$
Break-Before-Make Time Delay, t_D	12	1	1	ns typ ns min	$R_L = 300\ \Omega$, $C_L = 35\text{ pF}$; $V_S = 2\text{ V}$, see Figure 22
Charge Injection	± 3			pC typ	$V_S = 1.5\text{ V}$, $R_S = 0\ \Omega$, $C_L = 1\text{ nF}$; see Figure 23
Off Isolation	–55 –75			dB typ dB typ	$R_L = 50\ \Omega$, $C_L = 5\text{ pF}$, $f = 10\text{ MHz}$ $R_L = 50\ \Omega$, $C_L = 5\text{ pF}$, $f = 1\text{ MHz}$; see Figure 25
Channel-to-Channel Crosstalk	–55 –75			dB typ dB typ	$R_L = 50\ \Omega$, $C_L = 5\text{ pF}$, $f = 10\text{ MHz}$ $R_L = 50\ \Omega$, $C_L = 5\text{ pF}$, $f = 1\text{ MHz}$; see Figure 24
–3 dB Bandwidth				MHz typ MHz typ	
ADG738	65			MHz typ	$R_L = 50\ \Omega$, $C_L = 5\text{ pF}$, see Figure 25
ADG739	100			MHz typ	
C_S (Off)	13			pF typ	
C_D (Off)				pF typ pF typ	
ADG738	85			pF typ	
ADG739	42			pF typ	
C_D , C_S (On)				pF typ pF typ	
ADG738	96			pF typ	
ADG739	48			pF typ	
POWER REQUIREMENTS					
I_{DD}	10	20	20	μA typ μA max	$V_{DD} = 3.3\text{ V}$ Digital Inputs = 0 V or 3.3 V

¹ Guaranteed by design, not subject to production test.

TIMING CHARACTERISTICS

$V_{DD} = 2.7\text{ V to }5.5\text{ V}$. All specifications $-40^{\circ}\text{C to }+105^{\circ}\text{C}$, unless otherwise noted.

Table 3.

Parameter ^{1,2}	Limit at T_{MIN} / T_{MAX}		Unit	Test Conditions/Comments
	Min	Max		
f_{SCLK}		30	MHz	SCLK cycle frequency
t_1	33		ns	SCLK cycle time
t_2	13		ns	SCLK high time
t_3	13		ns	SCLK low time
t_4	0		ns	\overline{SYNC} to SCLK active edge setup time
t_5	5		ns	Data setup time
t_6	4.5		ns	Data hold time
t_7	0		ns	SCLK falling edge to \overline{SYNC} rising edge
t_8	33		ns	Minimum \overline{SYNC} high time
t_9^3	20		ns min	SCLK rising edge to DOUT valid

¹ See Figure 3.

² All input signals are specified with $t_r = t_f = 5\text{ ns}$ (10% to 90% of V_{DD}) and timed from a voltage level of $(V_{IL} + V_{IH})/2$.

³ $C_L = 20\text{ pF}$, $R_L = 1\text{ k}\Omega$.

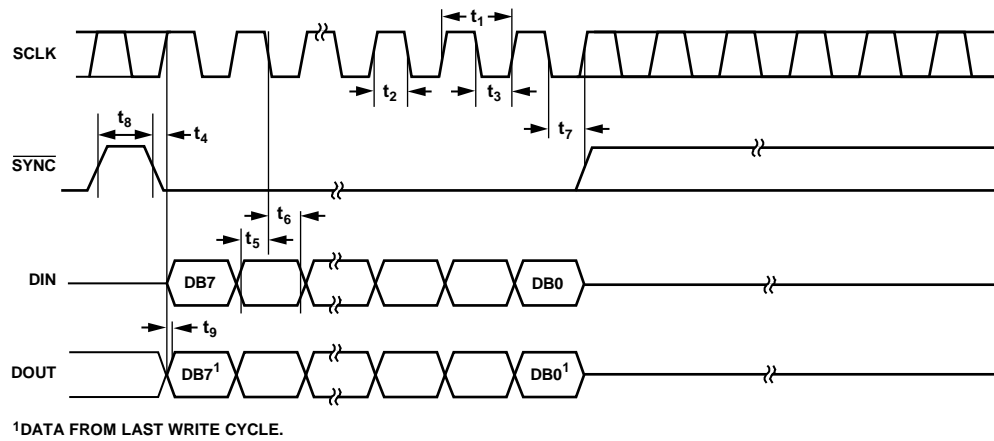

Figure 3. 3-Wire Serial Interface Timing Diagram

107558-003

ABSOLUTE MAXIMUM RATINGS

$T_A = 25^\circ\text{C}$ unless otherwise noted.

Table 4.

Parameter	Rating
V_{DD} to GND	-0.3 V to +7 V
Analog, Digital Inputs ¹	-0.3 V to $V_{DD} + 0.3$ V or 30 mA, Whichever Occurs First
Peak Current, S or D	100 mA (Pulsed at 1 ms, 10% Duty Cycle Max)
Continuous Current, Each S	30 mA
Continuous Current D	80 mA
ADG739	120 mA
ADG738	
Operating Temperature Range	
Industrial (B Version)	-40°C to +85°C
Industrial (W Version)	-40°C to +105°C
Storage Temperature Range	-65°C to +150°C
Junction Temperature	150°C
TSSOP Package	
θ_{JA} Thermal Impedance	150.4°C/W
θ_{JC} Thermal Impedance	27.6°C/W
Lead Temperature, Soldering	As per JEDEC J-STD-020

¹ Overvoltages at IN, S, or D are clamped by internal diodes. Limit current to the maximum ratings given.

Stresses above those listed under Absolute Maximum Ratings may cause permanent damage to the device. This is a stress rating only; functional operation of the device at these or any other conditions above those indicated in the operational section of this specification is not implied. Exposure to absolute maximum rating conditions for extended periods may affect device reliability.

ESD CAUTION



ESD (electrostatic discharge) sensitive device. Charged devices and circuit boards can discharge without detection. Although this product features patented or proprietary protection circuitry, damage may occur on devices subjected to high energy ESD. Therefore, proper ESD precautions should be taken to avoid performance degradation or loss of functionality.

PIN CONFIGURATIONS AND FUNCTION DESCRIPTIONS

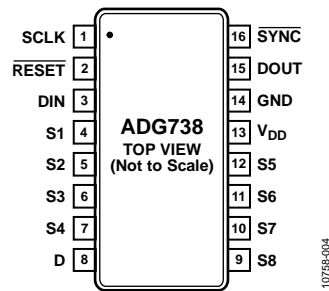

Figure 4. ADG738 Pin Configuration

Table 5. ADG738 Pin Function Descriptions

Pin No.	Mnemonic	Description
1	SCLK	Serial Clock Input. Data is clocked into the input shift register on the falling edge of the serial clock input. These devices can accommodate serial input rates of up to 30 MHz.
2	$\overline{\text{RESET}}$	Active Low Control Input. This pin clears the input register and turns all switches to the off condition.
3	DIN	Serial Data Input. Data is clocked into the 8-bit input register on the falling edge of the serial clock input.
4, 5, 6, 7	S1, S2, S3, S4	Source. May be an input or output.
8	D	Drain. May be an input or output.
9, 10, 11, 12	S8, S7, S6, S5	Source. May be an input or output.
13	V _{DD}	Power Supply Input. These parts can be operated from a supply of 2.7 V to 5.5 V.
14	GND	Ground Reference.
15	DOUT	Data Output. This allows a number a parts to be daisy-chained. Data is clocked out of the input shift register on the rising edge of SCLK. This is an open drain output, which should be pulled to the supply with an external resistor.
16	$\overline{\text{SYNC}}$	Active Low Control Input. This is the frame synchronization signal for the input data. When $\overline{\text{SYNC}}$ goes low, it powers on the SCLK and DIN buffers and the input shift register is enabled. Data is transferred on the falling edges of the following clocks. Taking $\overline{\text{SYNC}}$ high updates the switch conditions.

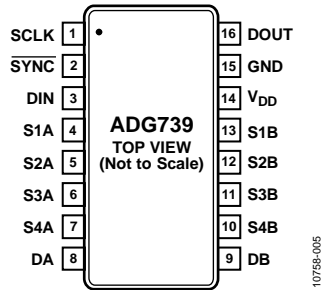

Figure 5. ADG739 Pin Configuration

Table 6. ADG739 Pin Function Descriptions

Pin No.	Mnemonic	Description
1	SCLK	Serial Clock Input. Data is clocked into the input shift register on the falling edge of the serial clock input. These devices can accommodate serial input rates of up to 30 MHz.
2	$\overline{\text{SYNC}}$	Active Low Control Input. This is the frame synchronization signal for the input data. When $\overline{\text{SYNC}}$ goes low, it powers on the SCLK and DIN buffers and the input shift register is enabled. Data is transferred on the falling edges of the following clocks. Taking $\overline{\text{SYNC}}$ high updates the switch conditions.
3	DIN	Serial Data Input. Data is clocked into the 8-bit input register on the falling edge of the serial clock input.
4, 5, 6, 7	S1A, S2A, S3A, S4A	Source. May be an input or output.
8, 9	DA, DB	Drain. May be an input or output.
10, 11, 12, 13	S4B, S3B, S2B, S1B	Source. May be an input or output.
14	V _{DD}	Power Supply Input. These parts can be operated from a supply of 2.7 V to 5.5 V.
15	GND	Ground Reference.
16	DOUT	Data Output. This allows a number a parts to be daisy-chained. Data is clocked out of the input shift register on the rising edge of SCLK. This is an open drain output, which should be pulled to the supply with an external resistor.

TYPICAL PERFORMANCE CHARACTERISTICS

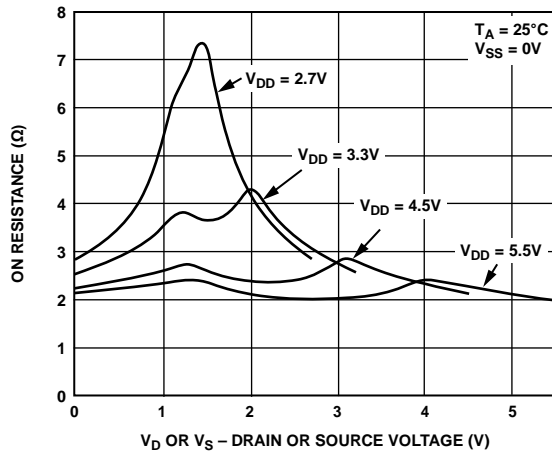

Figure 6. On Resistance as a Function of V_D (V_S)

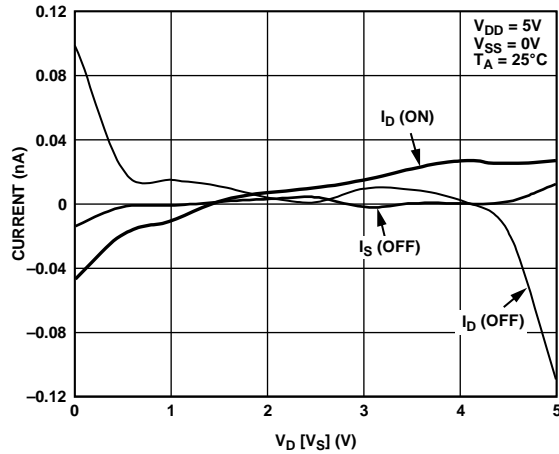

Figure 9. Leakage Currents as a Function of V_D (V_S), $V_{DD} = 5V$

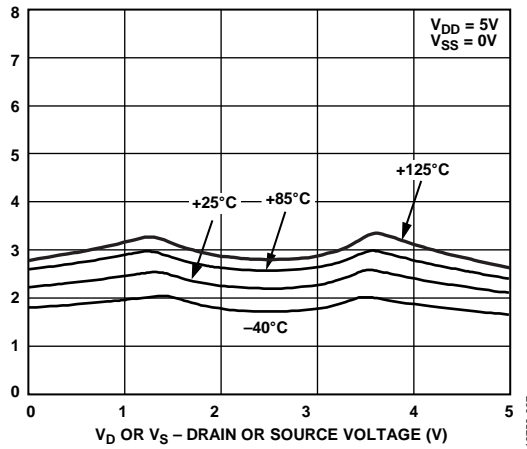

Figure 7. On Resistance as a Function of V_D (V_S) for Different Temperatures, $V_{DD} = 5V$

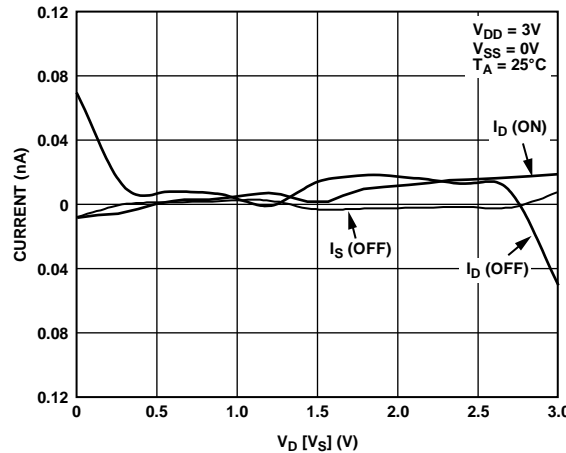

Figure 10. Leakage Currents as a Function of V_D (V_S), $V_{DD} = 3V$

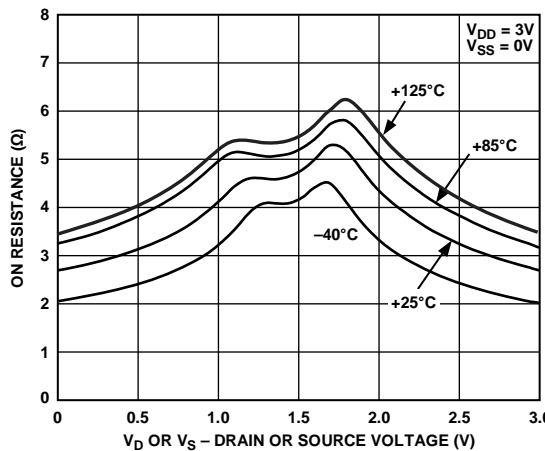

Figure 8. On Resistance as a Function of V_D (V_S) for Different Temperatures, $V_{DD} = 3V$

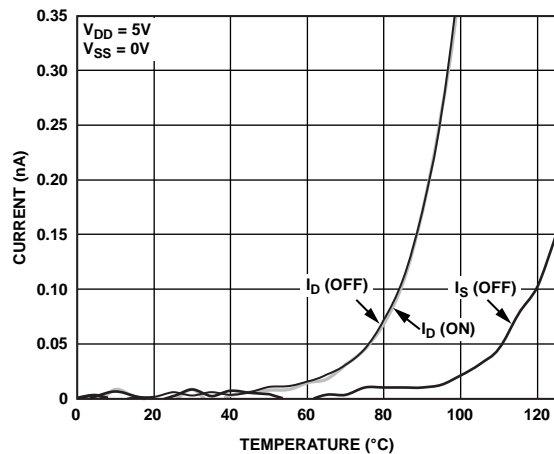

Figure 11. Leakage Currents as a Function of Temperature, $V_{DD} = 5V$

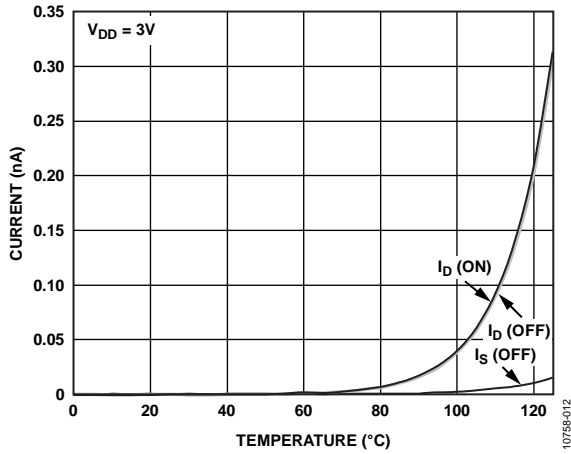

Figure 12. Leakage Currents as a Function of Temperature, $V_{DD} = 3V$

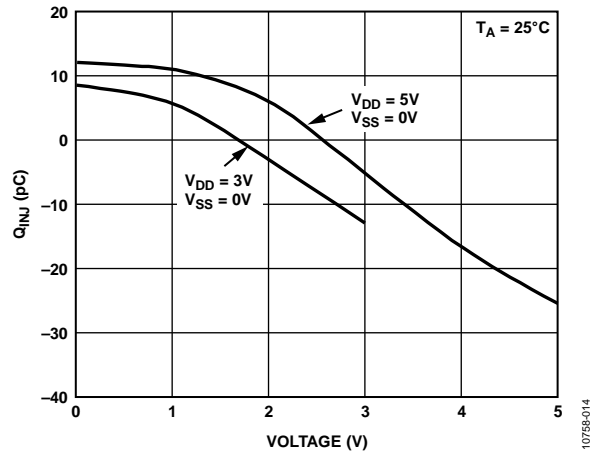

Figure 14. Charge Injection vs. Source Voltage

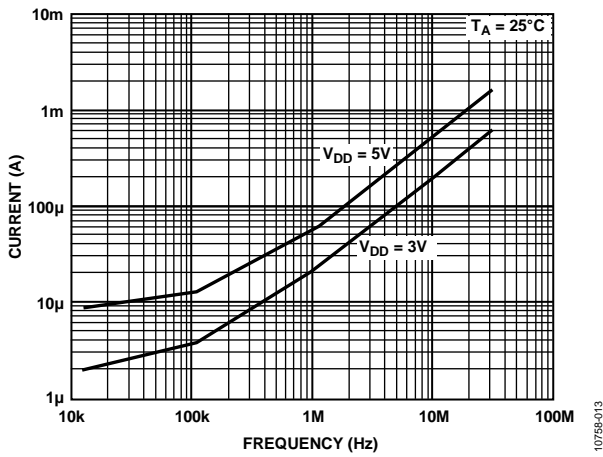

Figure 13. Input Currents vs. Switching Frequency

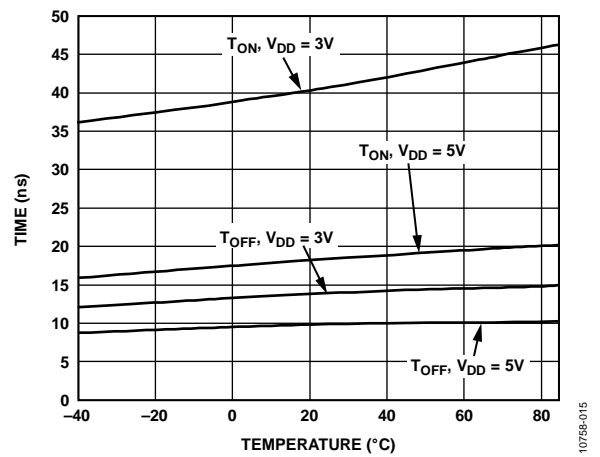

Figure 15. T_{ON}/T_{OFF} Times vs. Temperature

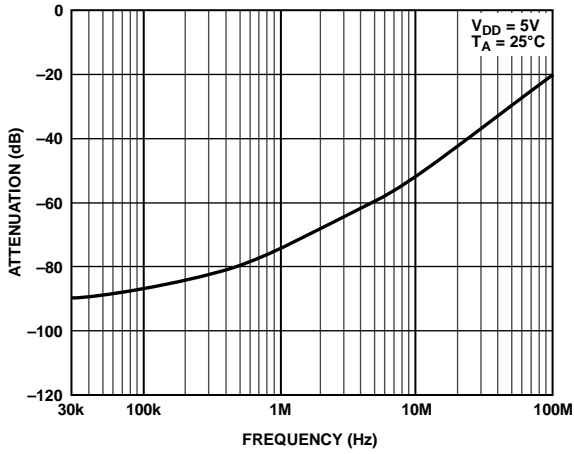

Figure 16. Off Isolation vs. Frequency

10758-016

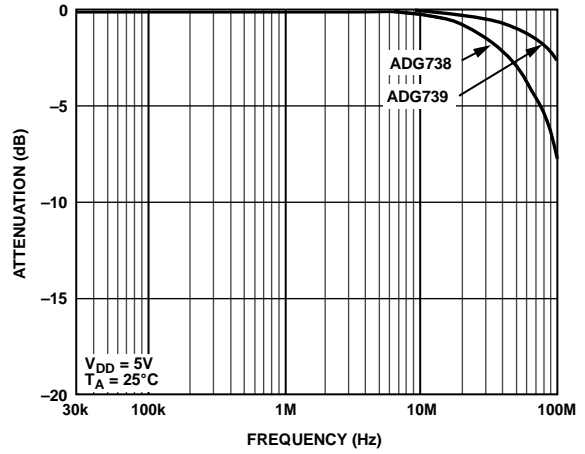

Figure 18. On Response vs. Frequency

10758-018

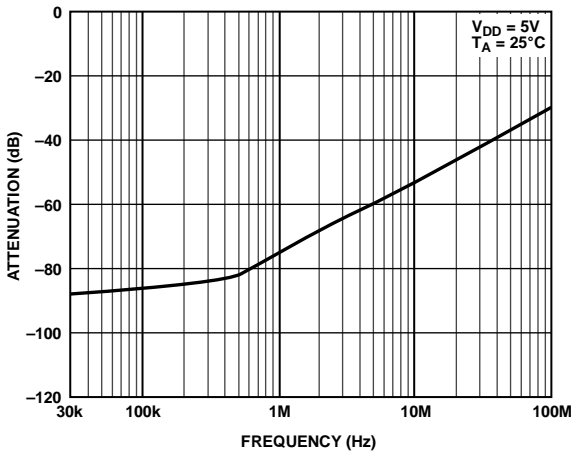

Figure 17. Crosstalk vs. Frequency

10758-017

TEST CIRCUITS

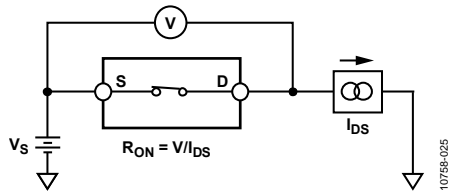

Figure 19. On Resistance

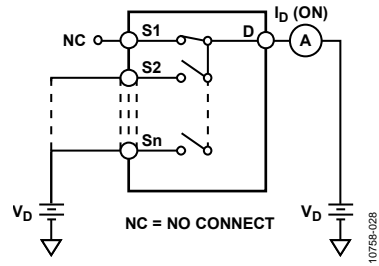

Figure 21. I_S, I_D (On)

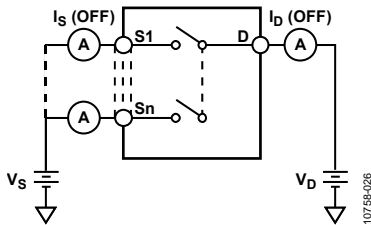
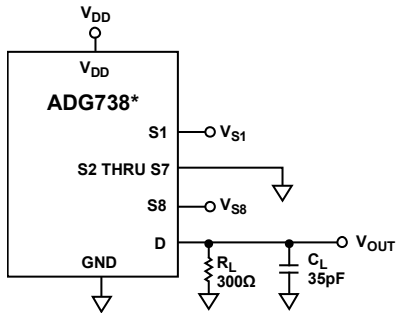

Figure 20. I_D (Off), I_S (Off)



*SIMILAR CONNECTION FOR ADG739.

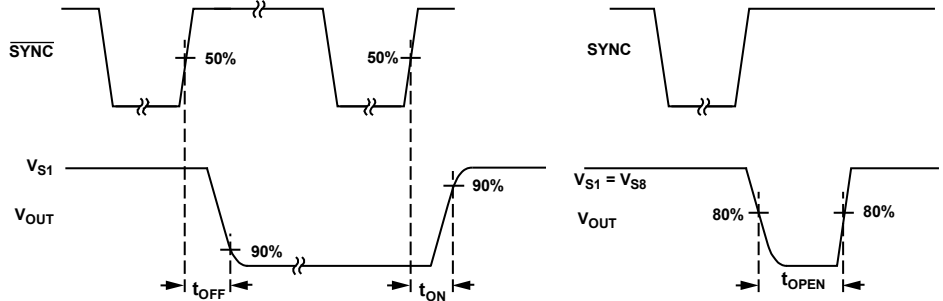
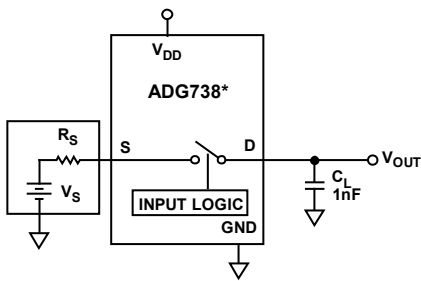
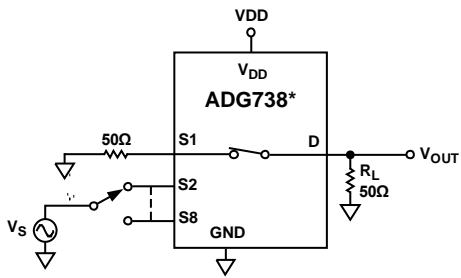

Figure 22. Switching Times and Break-Before-Make Times



*SIMILAR CONNECTION FOR ADG739.

Figure 23. Charge Injection



*SIMILAR CONNECTION FOR ADG739.

$$\text{CHANNEL-TO-CHANNEL CROSSTALK} = 20\text{LOG}_{10} (V_{\text{OUT}}/V_{\text{S}})$$

Figure 24. Channel-to-Channel Crosstalk

10758-031

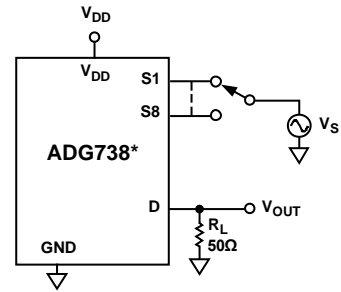

*SIMILAR CONNECTION FOR ADG739.

S1 IS SWITCHED OFF FOR OFF ISOLATION MEASUREMENTS AND ON FOR BANDWIDTH MEASUREMENTS

$$\text{OFF ISOLATION} = 20\text{LOG}_{10} (V_{\text{OUT}}/V_{\text{S}})$$

$$\text{INSERTION LOSS} = 20\text{LOG}_{10} \left(\frac{V_{\text{OUT WITH SWITCH}}}{V_{\text{OUT WITHOUT SWITCH}}} \right)$$

Figure 25. Off Isolation and Bandwidth

10758-032

TERMINOLOGY

V_{DD}

Most positive power supply potential.

I_{DD}

Positive supply current.

GND

Ground (0 V) reference.

S

Source terminal. May be an input or output.

D

Drain terminal. May be an input or output.

$V_D (V_S)$

Analog voltage on Terminal D, Terminal S.

R_{ON}

Ohmic resistance between D and S.

ΔR_{ON}

On resistance match between any two channels, that is, $R_{ON,max} - R_{ON,min}$.

$R_{FLAT(ON)}$

Flatness is defined as the difference between the maximum and minimum value of on resistance as measured over the specified analog signal range.

I_S (Off)

Source leakage current with the switch off.

I_D (Off)

Drain leakage current with the switch off.

I_D, I_S (On)

Channel leakage current with the switch on.

V_{INL}

Maximum input voltage for Logic 0.

V_{INH}

Minimum input voltage for Logic 1.

$I_{INL} (I_{INH})$

Input current of the digital input.

C_S (Off)

Off switch source capacitance. Measured with reference to ground.

C_D (Off)

Off switch drain capacitance. Measured with reference to ground.

C_D, C_S (On)

On switch capacitance. Measured with reference to ground.

C_{IN}

Digital input capacitance.

t_{ON}

Delay time between the 50% and 90% points of the \overline{SYNC} rising edge and the switch on condition.

t_{OFF}

Delay time between the 50% and 90% points of the \overline{SYNC} rising edge and the switch off condition.

t_D

Off time measured between the 80% points of both switches when switching from one switch to another.

Charge Injection

A measure of the glitch impulse transferred from the digital input to the analog output during switching.

Off Isolation

A measure of unwanted signal coupling through an off switch.

Crosstalk

A measure of unwanted signal which is coupled through from one channel to another as a result of parasitic capacitance.

Bandwidth

The frequency at which the output is attenuated by 3 dB.

On Response

The frequency response of the on switch.

Insertion Loss

The loss due to the on resistance of the switch.

THEORY OF OPERATION

The [ADG738](#) and [ADG739](#) are serially controlled, 8-channel and dual 4-channel matrix switches, respectively. While providing the normal multiplexing and demultiplexing functions, these parts also provide the user with more flexibility as to where their signal may be routed. Each bit of the 8-bit serial word corresponds to one switch of the part. A Logic 1 in the particular bit position turns on the switch, while a Logic 0 turns the switch off. Because each switch is independently controlled by an individual bit, this provides the option of having any, all, or none of the switches on. This feature may be particularly useful in the demultiplexing application where the user may wish to direct one signal from the drain to a number of outputs (sources). Take care, however, in the multiplexing situation where a number of inputs may be shorted together (separated only by the small on resistance of the switch).

When changing the switch conditions, a new 8-bit word is written to the input shift register. Some of the bits may be the same as the previous write cycle, as the user may not wish to change the state of some switches. To minimize glitches on the output of these switches, the part cleverly compares the state of switches from the previous write cycle. If the switch is already in the on condition, and is required to stay on, there will be minimal glitches on the output of the switch.

POWER-ON RESET

During device power-up, all switches will be in the off condition and the internal input shift register is filled with zeros and remains so until a valid write takes place.

SERIAL INTERFACE

The [ADG738](#) and [ADG739](#) have a 3-wire serial interface (SYNC, SCLK, and DIN), which is compatible with SPI, QSPI, MICROWIRE interface standards and most DSPs. Figure 3 shows the timing diagram of a typical write sequence.

Data is written to the 8-bit input shift register via DIN under the control of the SYNC and SCLK signals. Data may be written to the input shift register in more or less than eight bits. In each case, the input shift register retains the last eight bits that were written.

When $\overline{\text{SYNC}}$ goes low, the input shift register is enabled. Data from DIN is clocked into the input shift register on each falling edge of SCLK. Each bit of the 8-bit word corresponds to one of the eight switches. Figure 26 shows the contents of the input shift register. Data appears on the DOUT pin on the rising edge of SCLK suitable for daisy-chaining, delayed, of course, by eight bits. When all eight bits have been written into the shift register, the SYNC line is brought high again. The switches are updated with the new configuration and the input shift register is disabled. With $\overline{\text{SYNC}}$ held high, any further data or noise on the DIN line has no effect on the shift register.

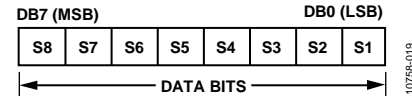

Figure 26. Input Shift Register Contents

MICROPROCESSOR INTERFACING

Microprocessor interfacing to the [ADG738/ADG739](#) is via a serial bus that uses a standard protocol compatible with microcontrollers and DSP processors. The communications channel is a 3-wire (minimum) interface consisting of a clock signal, a data signal, and a synchronization signal. The [ADG738/ADG739](#) requires an 8-bit data word with data valid on the falling edge of SCLK.

Data from the previous write cycle is available on the DOUT pin. The following sections illustrate simple 3-wire interfaces with popular microcontrollers and DSPs.

ADSP-21xx TO ADG738/ADG739

An interface between the [ADG738/ADG739](#) and the ADSP-21xx is shown in Figure 27. In the interface example shown, SPORT0 is used to transfer data to the matrix switch. The SPORT control register should be configured as follows: internal clock operation, alternate framing mode; active low framing signal.

Transmission is initiated by writing a word to the Tx register after the SPORT has been enabled. As the data is clocked out of the DSP on the rising edge of SCLK, no glue logic is required to interface the DSP to the matrix switch. The update of each switch condition takes place automatically when TFS is taken high.

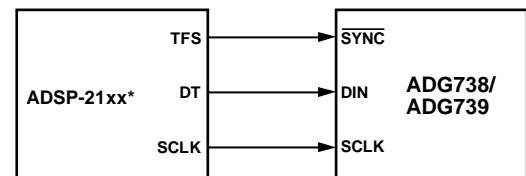

*ADDITIONAL PINS OMITTED FOR CLARITY.

Figure 27. ADSP-21xx to [ADG738/ADG739](#) Interface

8051 INTERFACE TO ADG738/ADG739

A serial interface between the ADG738/ADG739 and the 8051 is shown in Figure 28. TXD of the 8051 drives SCLK of the ADG738/ADG739, while RXD drives the serial data line, DIN. P3.3 is a bit-programmable pin on the serial port and is used to drive SYNC.

The 8051 provides the LSB of its SBUF register as the first bit in the data stream. The user has to ensure that the data in the SBUF register is arranged correctly as the switch expects MSB first.

When data is to be transmitted to the matrix switch, P3.3 is taken low. Data on RXD is clocked out of the microcontroller on the rising edge of TXD and is valid on the falling edge. As a result no glue logic is required between the ADG738/ADG739 and microcontroller interface.

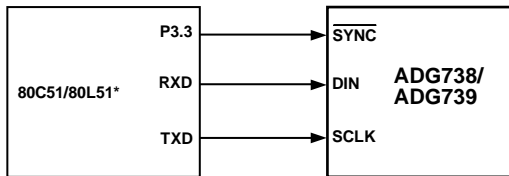

*ADDITIONAL PINS OMITTED FOR CLARITY.

Figure 28. 8051 Interface to ADG738/ADG739

10758-021

MC68HC11 INTERFACE TO ADG738/ADG739

Figure 29 shows an example of a serial interface between the ADG738/ADG739 and the MC68HC11 microcontroller. SCK of the 68HC11 drives the SCLK of the matrix switch, while the MOSI output drives the serial data line, DIN. SYNC is driven from one of the port lines, in this case PC7.

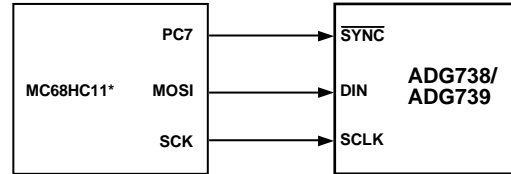

*ADDITIONAL PINS OMITTED FOR CLARITY.

Figure 29. MC68HC11 Interface to ADG738/ADG739

10758-022

The 68HC11 is configured for master mode; MSTR = 1, CPOL = 0, and CPHA = 1. When data is transferred to the part, PC7 is taken low, data is transmitted MSB first. Data appearing on the MOSI output is valid on the falling edge of SCK.

If the user wishes to verify the data previously written to the input shift register, the DOUT line could be connected to MISO of the MC68HC11, and with SYNC low, the input shift register would clock data out on the rising edges of SCLK.

APPLICATIONS INFORMATION

EXPAND THE NUMBER OF SELECTABLE SERIAL DEVICES USING AN ADG739

The dual 4-channel [ADG739](#) multiplexer can be used to multiplex a single chip select line to provide chip selects for up to four devices on the SPI bus. Figure 30 illustrates the [ADG739](#) in such a typical configuration. All devices receive the same serial clock and serial data, but only one device receives the SYNC signal at any one time. The [ADG739](#) is a serially controlled device also. One bit programmable pin of the microcontroller is used to enable the [ADG739](#) via SYNC2, while another bit programmable pin is used as the chip select for the other serial devices, SYNC1. Driving SYNC2 low enables changes to be made to the addressed serial devices. By bringing SYNC1 low, the selected serial device hanging from the SPI bus is enabled and data will be clocked into its input shift register on the falling edges of SCLK. The convenient design of the matrix switch allows for different combinations of the four serial devices to be addressed at any one time. If more devices need to be addressed via one chip select line, the [ADG738](#) is an 8-channel device and would allow further expansion of the chip select scheme. There may be some digital feedthrough from the digital input lines because SCLK and DIN are permanently connected to each device. Using a burst clock minimizes the effects of digital feedthrough on the analog channels.

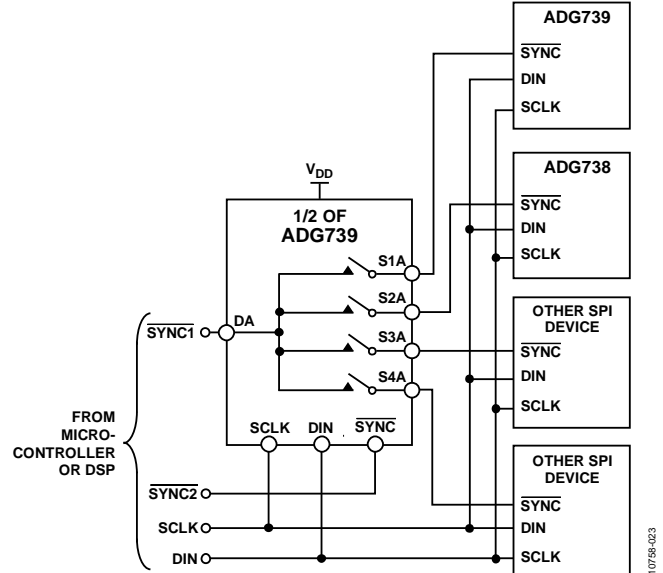

Figure 30. Addressing Multiple Serial Devices Using an [ADG739](#)

DAISY-CHAINING MULTIPLE ADG738S

A number of [ADG738](#) matrix switches may be daisy-chained simply by using the DOUT pin. DOUT is an open-drain output that should be pulled to the supply with an external resistor. Figure 31 shows a typical implementation. The SYNC pin of all three parts in the example are tied together. When SYNC is brought low, the input shift registers of all parts are enabled, data is written to the parts via DIN, and clocked through the shift registers. When the transfer is complete, SYNC is brought high and all switches are updated simultaneously. Further shift registers may be added in series.

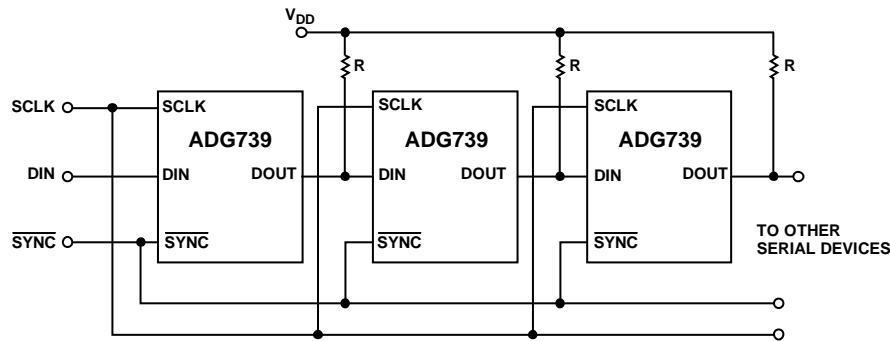
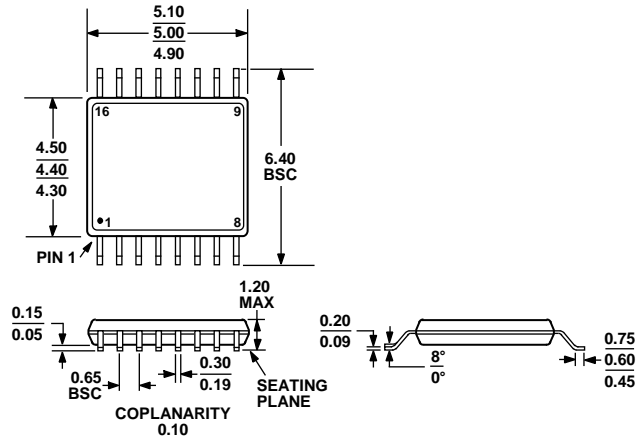

Figure 31. Multiple [ADG739](#) Devices in a Daisy-Chained Configuration

OUTLINE DIMENSIONS



COMPLIANT TO JEDEC STANDARDS MO-153-AB

Figure 32. 16-Lead Thin Shrink Small Outline Package [TSSOP] (RU-16)

Dimensions shown in millimeters

ORDERING GUIDE

Model ^{1,2}	Temperature Range	Package Description	Package Option
ADG738BRU	-40°C to +85°C	16-Lead Thin Shrink Small Outline Package [TSSOP]	RU-16
ADG738BRUZ	-40°C to +85°C	16-Lead Thin Shrink Small Outline Package [TSSOP]	RU-16
ADG738BRUZ-REEL	-40°C to +85°C	16-Lead Thin Shrink Small Outline Package [TSSOP]	RU-16
ADG738BRUZ-REEL7	-40°C to +85°C	16-Lead Thin Shrink Small Outline Package [TSSOP]	RU-16
ADG738WBRUZ-REEL	-40°C to +105°C	16-Lead Thin Shrink Small Outline Package [TSSOP]	RU-16
ADG739BRU	-40°C to +85°C	16-Lead Thin Shrink Small Outline Package [TSSOP]	RU-16
ADG739BRUZ-REEL7	-40°C to +85°C	16-Lead Thin Shrink Small Outline Package [TSSOP]	RU-16
ADG739BRUZ	-40°C to +85°C	16-Lead Thin Shrink Small Outline Package [TSSOP]	RU-16
ADG739BRUZ-REEL	-40°C to +85°C	16-Lead Thin Shrink Small Outline Package [TSSOP]	RU-16
ADG739BRUZ-REEL7	-40°C to +85°C	16-Lead Thin Shrink Small Outline Package [TSSOP]	RU-16

¹ Z = RoHS Compliant Part.

² W = Qualified for Automotive Applications.

AUTOMOTIVE PRODUCTS

The ADG738W model is available with controlled manufacturing to support the quality and reliability requirements of automotive applications. Note that this automotive model may have specifications that differ from the commercial models; therefore, designers should review the Specifications section of this data sheet carefully. Only the automotive grade products shown are available for use in automotive applications. Contact your local Analog Devices account representative for specific product ordering information and to obtain the specific Automotive Reliability reports for these models.

NOTES

NOTES

Looking for pricing, stock, or lifecycle information?

Click below to explore more details on WIN SOURCE:

 [View ADG738BRUZ on WIN SOURCE](#)

 [Analog Devices Inc. Information](#)

Optimize Your Supply Chain with WIN SOURCE Solutions

-  Global Sourcing Solution
-  Obsolete Management
-  Cost Control Management
-  Shortage Management
-  Alternative Solution
-  Excess Inventory Management