



**THE DATASHEET OF
LM101AJ**



LM101A/LM201A/LM301A Operational Amplifiers

 Check for Samples: [LM101A-N](#), [LM201A-N](#), [LM301A-N](#)

FEATURES

- Improved Specifications include:
- Offset Voltage 3 mV Maximum Over Temperature (LM101A/LM201A)
- Input Current 100 nA Maximum Over Temperature (LM101A/LM201A)
- Offset Current 20 nA Maximum Over Temperature (LM101A/LM201A)
- Specified Drift Characteristics
- Offsets Specified Over Entire Common Mode and Supply Voltage Ranges
- Slew Rate of 10V/μs as a Summing Amplifier

DESCRIPTION

The LM101A series are general purpose operational amplifiers which feature improved performance over industry standards like the LM709. Advanced processing techniques make possible an order of magnitude reduction in input currents, and a redesign of the biasing circuitry reduces the temperature drift of input current.

This amplifier offers many features which make its application nearly foolproof: Overload protection on the input and output, no latch-up when the common mode range is exceeded, and freedom from oscillations and compensation with a single 30 pF Capacitor. It has advantages over internally compensated amplifiers in that the frequency compensation can be tailored to the particular application. For example, in low frequency circuits it can be overcompensated for increased stability margin or the compensation can be optimized to give more than a factor of ten improvement in high frequency performance for most applications.

In Addition, the device provides better accuracy and lower noise in high impedance circuitry. The low input currents also make it particularly well suited for long interval integrators or timers, sample and hold circuits and low frequency waveform generators. Further, replacing circuits where matched transistor pairs buffer the inputs of conventional IC op amps, It can give lower offset voltage and a drift at a lower cost.

The LM101A is ensured over a temperature range of -55°C to +125°C, the LM201A from -25°C to +85°C, and the LM301A from 0°C to +70°C.

Fast AC-DC Converter

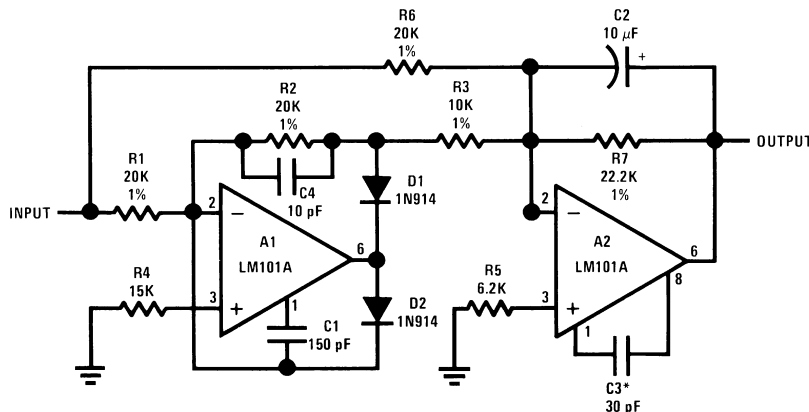

Feedforward compensation can be used to make a fast full wave rectifier without a filter.



Please be aware that an important notice concerning availability, standard warranty, and use in critical applications of Texas Instruments semiconductor products and disclaimers thereto appears at the end of this data sheet.



These devices have limited built-in ESD protection. The leads should be shorted together or the device placed in conductive foam during storage or handling to prevent electrostatic damage to the MOS gates.

Absolute Maximum Ratings⁽¹⁾⁽²⁾

	LM101A/LM201A	LM301A
Supply Voltage	±22V	±18V
Differential Input Voltage	±30V	±30V
Input Voltage ⁽³⁾	±15V	±15V
Output Short Circuit Duration ⁽⁴⁾	Continuous	Continuous
Operating Ambient Temp. Range	-55°C to +125°C (LM101A)	0°C to +70°C
	-25°C to +85°C (LM201A)	
T _J Max		
LMC0008C Package	150°C	100°C
P0008E Package	150°C	100°C
NAB0008A, J0014A Package	150°C	100°C
Power Dissipation at T _A = 25°C		
LMC0008C-Package (Still Air) (400 LF/Min Air Flow)	500 mW	300 mW
	1200 mW	700 mW
P0008E Package	900 mW	500 mW
NAB0008A, J0014A Package	1000 mW	650 mW
Thermal Resistance (Typical) θ _{JA}		
LMC0008C Package (Still Air) (400 LF/Min Air Flow)	165°C/W	165°C/W
	67°C/W	67°C/W
P0008E Package	135°C/W	135°C/W
NAB0008A, J0014A Package	110°C/W	110°CmW
(Typical) θ _{JC}		
LMC0008C Package	25°C/W	25°C/W
Storage Temperature Range	-65°C to +150°C	-65°C to +150°C
Lead Temperature (Soldering, 10 sec.)		
LMC0008C or NAB0008A, J0014A, NAD0010A	300°C	300°C
P0008E	260°C	260°C
ESD Tolerance ⁽⁵⁾	2000V	2000V

- (1) Absolute Maximum Ratings indicate limits beyond which damage to the device may occur. Operating ratings indicate for which the device is functional, but do not ensure specific performance limits. Electrical Characteristics state DC and AC electrical specifications under particular test conditions which ensure specific limits. This assumes that the device is within the Operating Ratings. Specifications are not ensured for parameters where no limit is given, however, the typical value is a good indication of device performance.
- (2) If Military/Aerospace specified devices are required, please contact the Texas Instruments Sales Office/Distributors for availability and specifications.
- (3) For supply voltages less than ±15V, the absolute maximum input voltage is equal to the supply voltage.
- (4) Continuous short circuit is allowed for case temperatures to 125°C and ambient temperatures to 75°C for LM101A/LM201A, and 70°C and 55°C respectively for LM301A.
- (5) Human body model, 100 pF discharged through 1.5 kΩ.

Electrical Characteristics⁽¹⁾

$T_A = T_J$

Parameter	Test Conditions	LM101A/LM201A			LM301A			Units	
		Min	Typ	Max	Min	Typ	Max		
Input Offset Voltage	$T_A = 25^\circ\text{C}$, $R_S \leq 50\text{ k}\Omega$		0.7	2.0		2.0	7.5	mV	
Input Offset Current	$T_A = 25^\circ\text{C}$		1.5	10		3.0	50	nA	
Input Bias Current	$T_A = 25^\circ\text{C}$		30	75		70	250	nA	
Input Resistance	$T_A = 25^\circ\text{C}$	1.5	4.0		0.5	2.0		M Ω	
Supply Current	$T_A = 25^\circ\text{C}$	$V_S = \pm 20\text{V}$		1.8	3.0				mA
		$V_S = \pm 15\text{V}$					1.8	3.0	mA
Large Signal Voltage Gain	$T_A = 25^\circ\text{C}$, $V_S = \pm 15\text{V}$ $V_{\text{OUT}} = \pm 10\text{V}$, $R_L \geq 2\text{ k}\Omega$	50	160		25	160		V/mV	
Input Offset Voltage	$R_S \leq 50\text{ k}\Omega$			3.0			10	mV	
Average Temperature Coefficient of Input Offset Voltage	$R_S \leq 50\text{ k}\Omega$		3.0	15		6.0	30	$\mu\text{V}/^\circ\text{C}$	
Input Offset Current				20			70	nA	
Average Temperature Coefficient of Input Offset Current	$25^\circ\text{C} \leq T_A \leq T_{\text{MAX}}$ $T_{\text{MIN}} \leq T_A \leq 25^\circ\text{C}$		0.01	0.1		0.01	0.3	nA/ $^\circ\text{C}$	
			0.02	0.2		0.02	0.6	nA/ $^\circ\text{C}$	
Input Bias Current				0.1			0.3	μA	
Supply Current	$T_A = T_{\text{MAX}}$, $V_S = \pm 20\text{V}$		1.2	2.5				mA	
Large Signal Voltage Gain	$V_S = \pm 15\text{V}$, $V_{\text{OUT}} = \pm 10\text{V}$ $R_L \geq 2\text{ k}\Omega$	25			15			V/mV	
Output Voltage Swing	$V_S = \pm 15\text{V}$	$R_L = 10\text{ k}\Omega$	± 12	± 14		± 12	± 14	V	
		$R_L = 2\text{ k}\Omega$	± 10	± 13		± 10	± 13	V	
Input Voltage Range	$V_S = \pm 20\text{V}$	± 15						V	
	$V_S = \pm 15\text{V}$		+15, -13		± 12	+15, -13		V	
Common-Mode Rejection Ratio	$R_S \leq 50\text{ k}\Omega$	80	96		70	90		dB	
Supply Voltage Rejection Ratio	$R_S \leq 50\text{ k}\Omega$	80	96		70	96		dB	

(1) Unless otherwise specified, these specifications apply for $C_1 = 30\text{ pF}$, $\pm 5\text{V} \leq V_S \leq \pm 20\text{V}$ and $-55^\circ\text{C} \leq T_A \leq +125^\circ\text{C}$ (LM101A), $\pm 5\text{V} \leq V_S \leq \pm 20\text{V}$ and $-25^\circ\text{C} \leq T_A \leq +85^\circ\text{C}$ (LM201A), $\pm 5\text{V} \leq V_S \leq \pm 15\text{V}$ and $0^\circ\text{C} \leq T_A \leq +70^\circ\text{C}$ (LM301A).

Typical Performance Characteristics

LM101A/LM201A

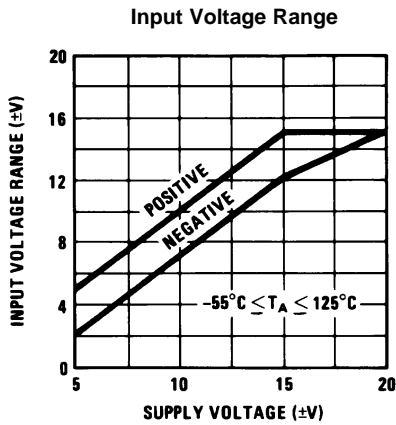

Figure 1.

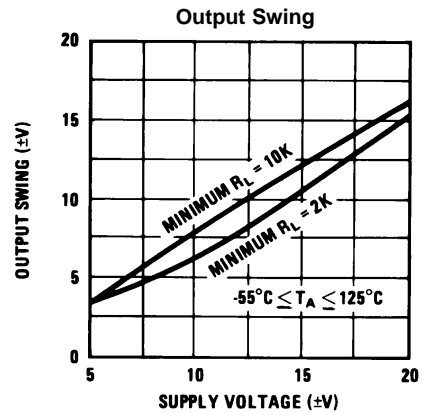

Figure 2.

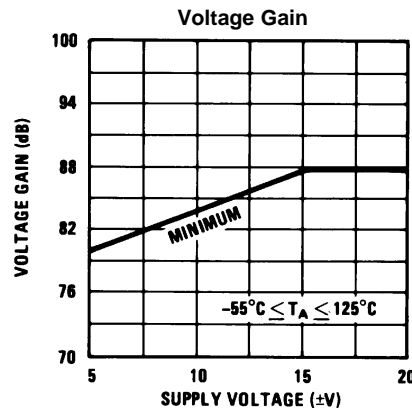

Figure 3.

Performance Characteristics

LM301A

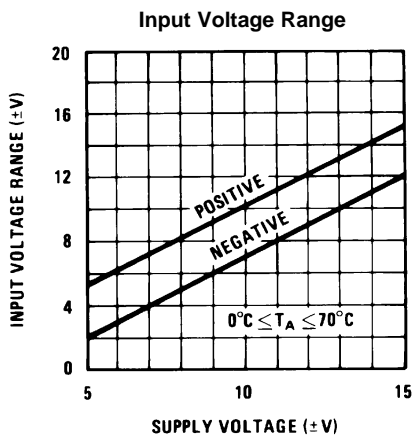

Figure 4.

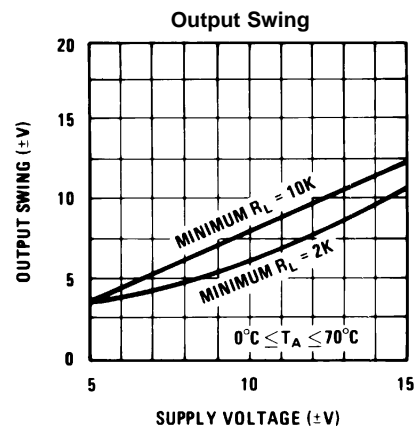

Figure 5.

Performance Characteristics (continued)

LM301A

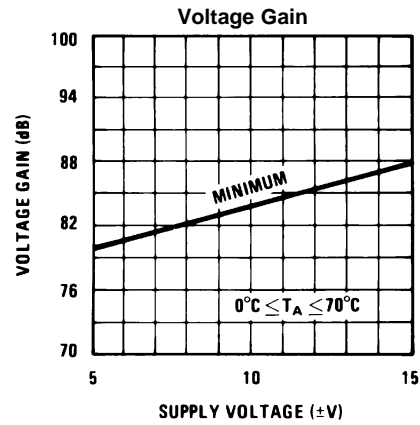

Figure 6.

Typical Performance Characteristics

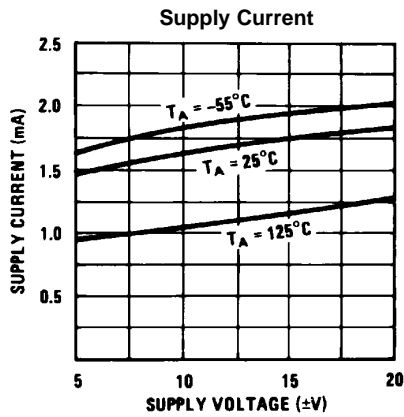

Figure 7.

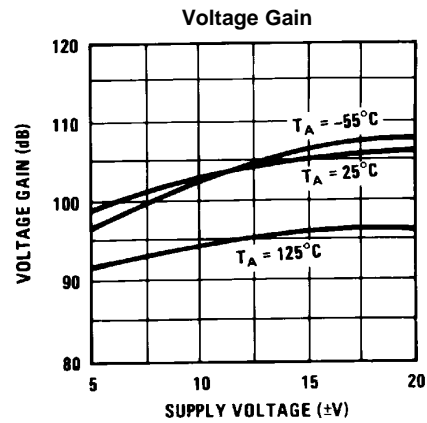

Figure 8.

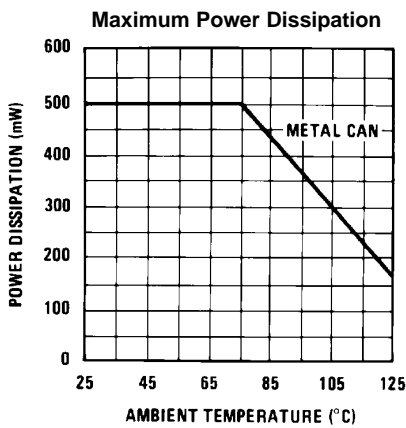

Figure 9.

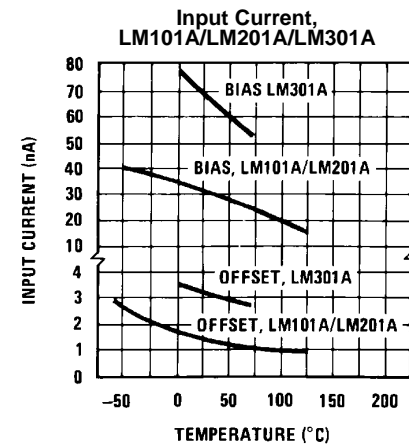

Figure 10.

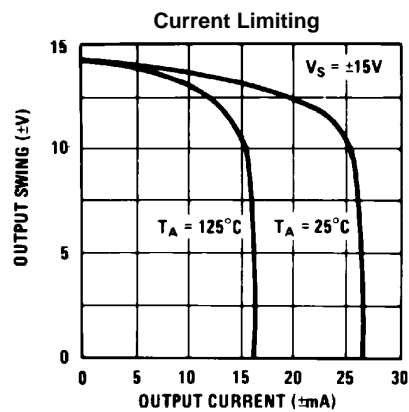

Figure 11.

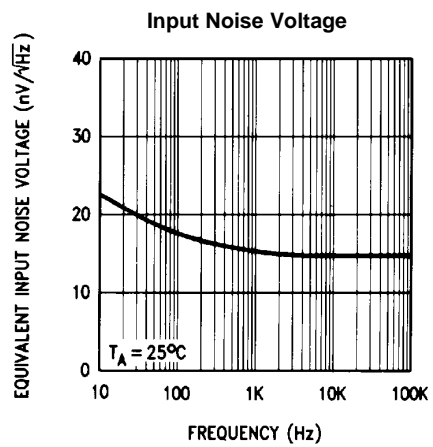
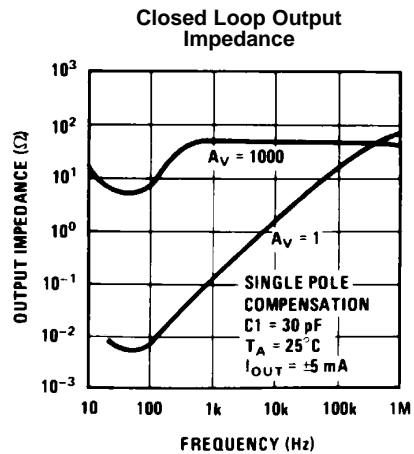
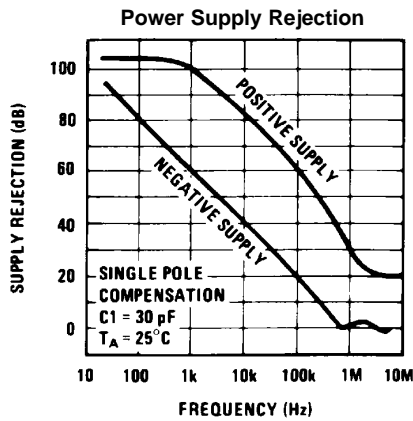
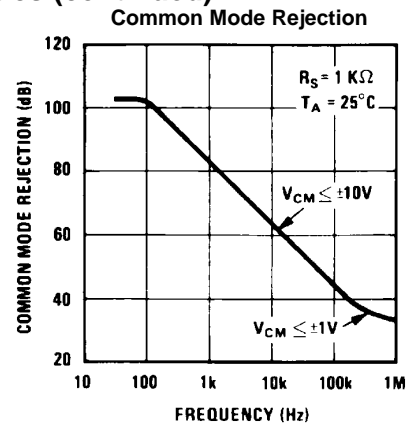
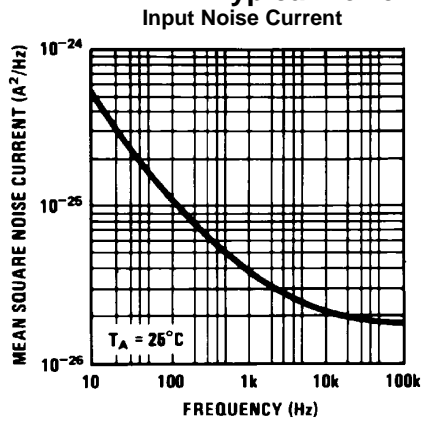

Figure 12.

Typical Performance Characteristics (continued)



Typical Performance Characteristics for Various Compensation Circuits

Pin connections shown are for 8-pin packages.

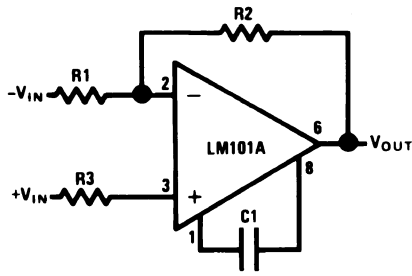

$$C1 \geq \frac{R1 C_S}{R1 + R2}$$

$$C_S = 30 \text{ pF}$$

Figure 17. Single Pole Compensation

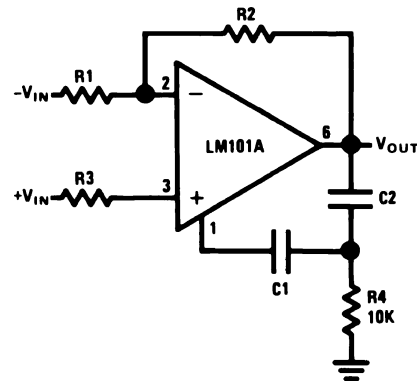

$$C1 \geq \frac{R1 C_S}{R1 + R2}$$

$$C_S = 30 \text{ pF}$$

$$C2 = 10 C1$$

Figure 18. Two Pole Compensation

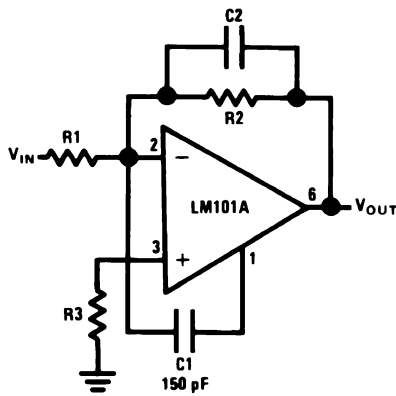

$$C2 = \frac{1}{2\pi f_0 R2}$$

$$f_0 = 3 \text{ MHz}$$

Figure 19. Feedforward Compensation

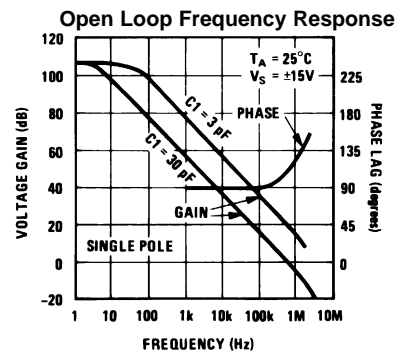

Figure 20.

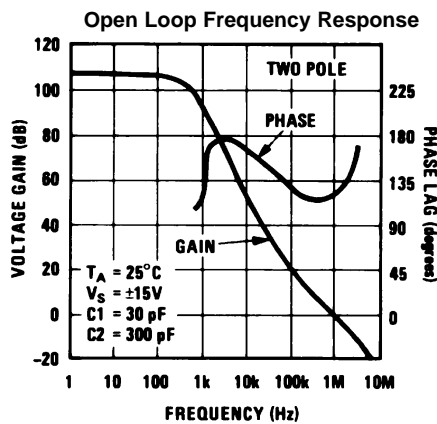

Figure 21.

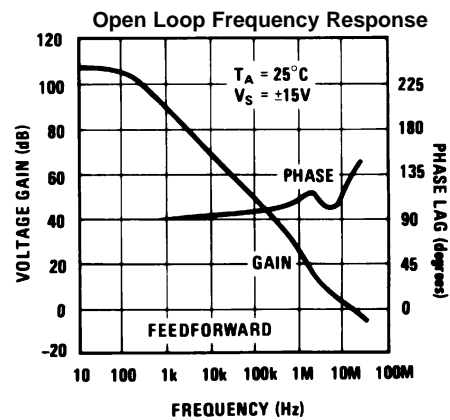

Figure 22.

Typical Performance Characteristics for Various Compensation Circuits (continued)

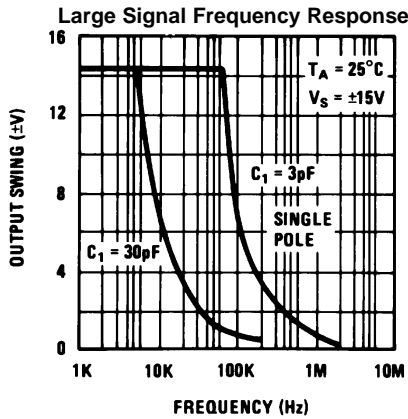

Figure 23.

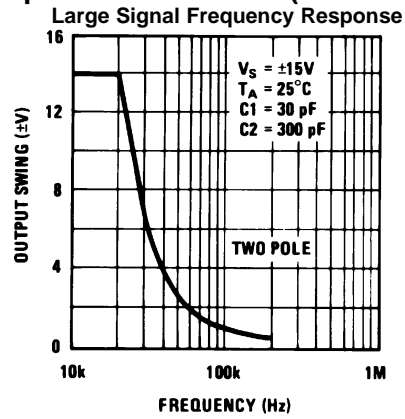

Figure 24.

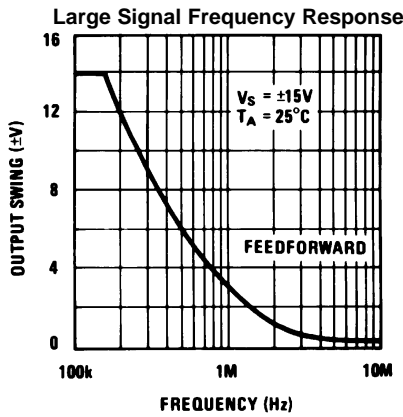

Figure 25.

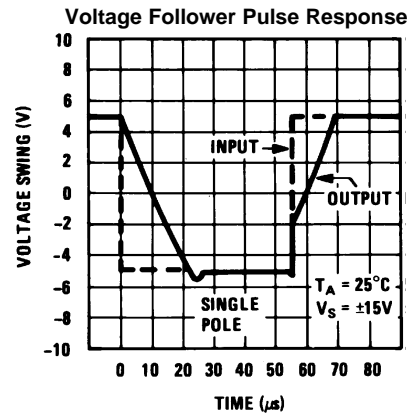

Figure 26.

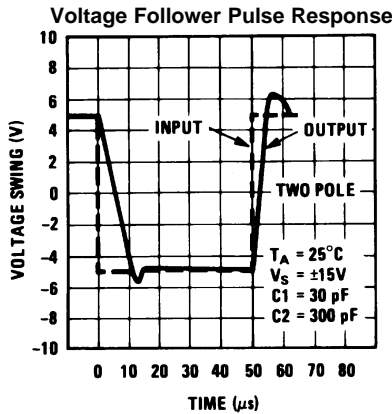

Figure 27.

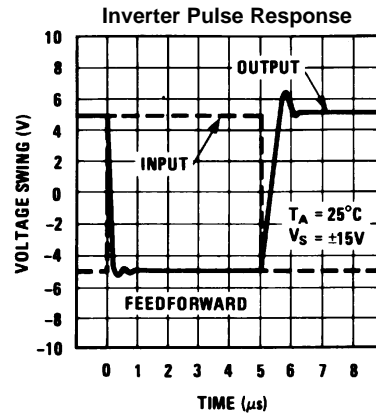
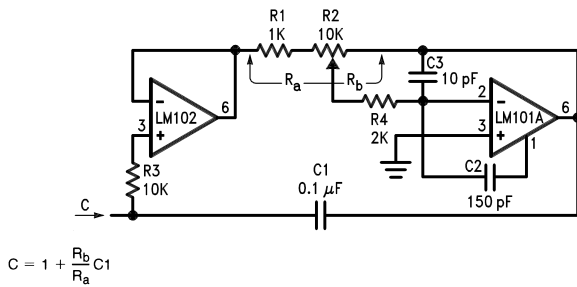

Figure 28.

TYPICAL APPLICATIONS

Pin connections shown are for 8-pin packages



$$C = 1 + \frac{R_b}{R_a} C_1$$

Figure 29. Variable Capacitance Multiplier

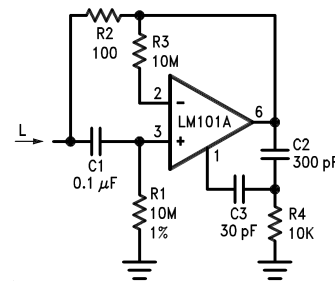

$$L = R_1 R_2 C_1$$

$$R_S = R_2$$

$$R_P = R_1$$

Figure 30. Simulated Inductor

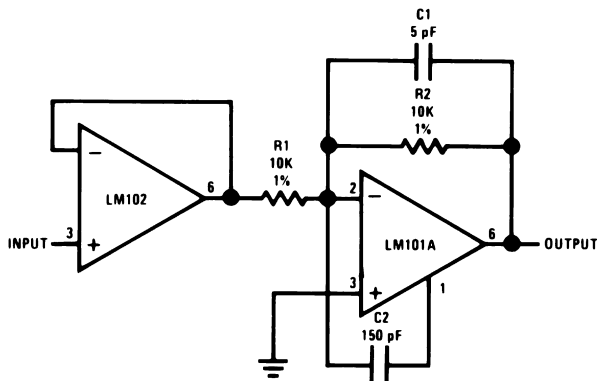
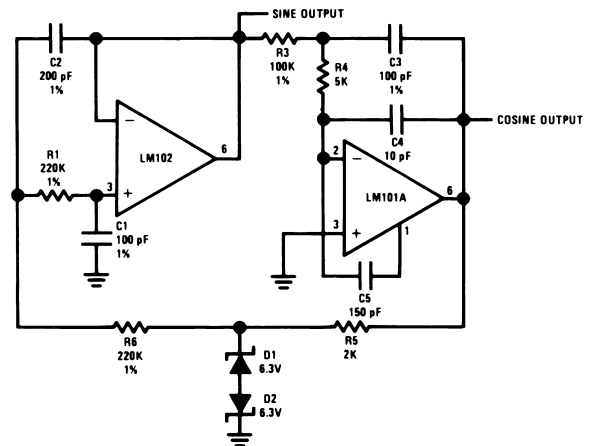
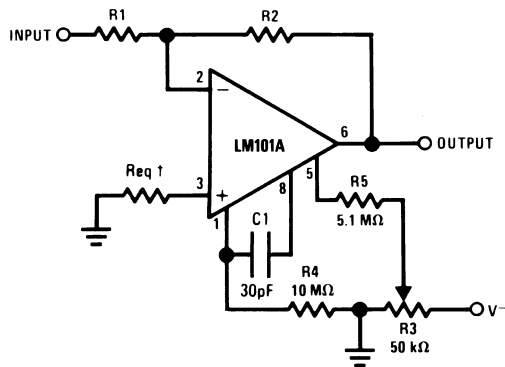

Figure 31. Fast Inverting Amplifier with High Input Impedance



f_o = 10 kHz

Figure 33. Sine Wave Oscillator



†May be zero or equal to parallel combination of R1 and R2 for minimum offset.

Figure 32. Inverting Amplifier with Balancing Circuit

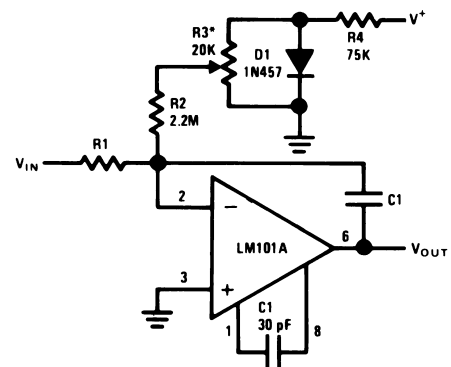

*Adjust for zero integrator drift. Current drift typically 0.1 nA/°C over -55°C to +125°C temperature range.

Figure 34. Integrator with Bias Current Compensation

Application Hints

Pin connections shown are for 8-pin packages.

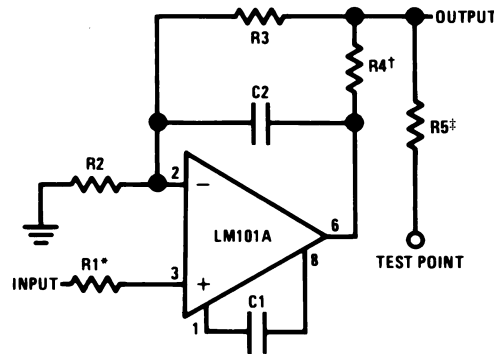

*Protects input

†Protects output

‡Protects output—not needed when R4 is used.

Figure 35. Protecting Against Gross Fault Conditions

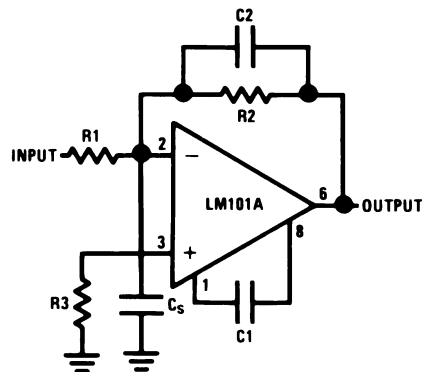

$$C_2 = \frac{R_1 C_s}{R_2}$$

Figure 36. Compensating for Stray Input Capacitances or Large Feedback Resistor

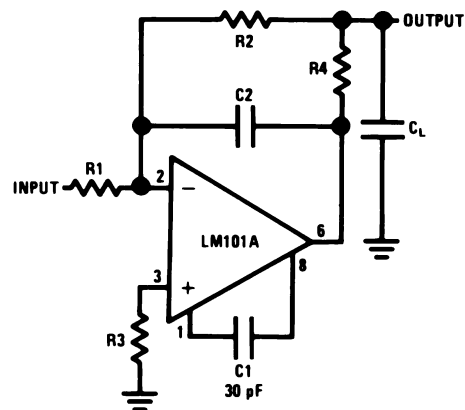

Figure 37. Isolating Large Capacitive Loads

Although the LM101A is designed for trouble free operation, experience has indicated that it is wise to observe certain precautions given below to protect the devices from abnormal operating conditions. It might be pointed out that the advice given here is applicable to practically any IC op amp, although the exact reason why may differ with different devices.

When driving either input from a low-impedance source, a limiting resistor should be placed in series with the input lead to limit the peak instantaneous output current of the source to something less than 100 mA. This is especially important when the inputs go outside a piece of equipment where they could accidentally be connected to high voltage sources. Large capacitors on the input (greater than 0.1 μF) should be treated as a low source impedance and isolated with a resistor. Low impedance sources do not cause a problem unless their output voltage exceeds the supply voltage. However, the supplies go to zero when they are turned off, so the isolation is usually needed.

The output circuitry is protected against damage from shorts to ground. However, when the amplifier output is connected to a test point, it should be isolated by a limiting resistor, as test points frequently get shorted to bad places. Further, when the amplifier drives a load external to the equipment, it is also advisable to use some sort of limiting resistance to preclude mishaps.

Precautions should be taken to insure that the power supplies for the integrated circuit never become reversed—even under transient conditions. With reverse voltages greater than 1V, the IC will conduct excessive current, fusing internal aluminum interconnects. If there is a possibility of this happening, clamp diodes with a high peak current rating should be installed on the supply lines. Reversal of the voltage between V^+ and V^- will always cause a problem, although reversals with respect to ground may also give difficulties in many circuits.

The minimum values given for the frequency compensation capacitor are stable only for source resistances less than 10 k Ω , stray capacitances on the summing junction less than 5 pF and capacitive loads smaller than 100 pF. If any of these conditions are not met, it becomes necessary to overcompensate the amplifier with a larger compensation capacitor. Alternately, lead capacitors can be used in the feedback network to negate the effect of stray capacitance and large feedback resistors or an RC network can be added to isolate capacitive loads.

Although the LM101A is relatively unaffected by supply bypassing, this cannot be ignored altogether. Generally it is necessary to bypass the supplies to ground at least once on every circuit card, and more bypass points may be required if more than five amplifiers are used. When feed-forward compensation is employed, however, it is advisable to bypass the supply leads of each amplifier with low inductance capacitors because of the higher frequencies involved.

Typical Applications

Pin connections shown are for 8-pin packages.

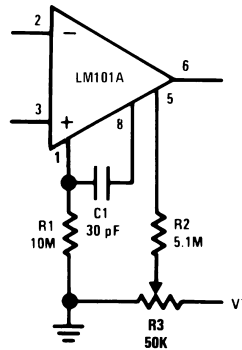
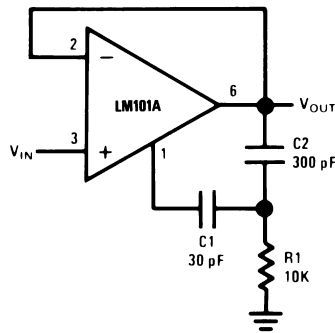
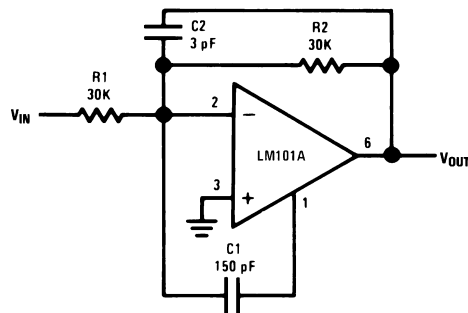

Figure 38. Standard Compensation and Offset Balancing Circuit



Power Bandwidth: 15 kHz
Slew Rate: 1V/ μ s

Figure 39. Fast Voltage Follower



Power Bandwidth: 250 kHz
Small Signal Bandwidth: 3.5 MHz
Slew Rate: 10V/ μ s

Figure 40. Fast Summing Amplifier

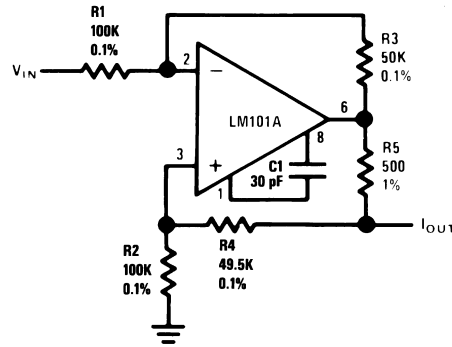

$$I_{OUT} = \frac{R3 V_{IN}}{R1 R5}$$

$$R3 = R4 + R5$$

$$R1 = R2$$

Figure 41. Bilateral Current Source

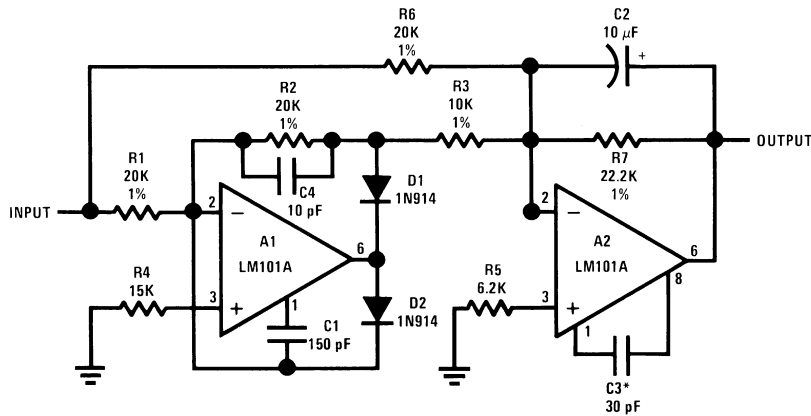
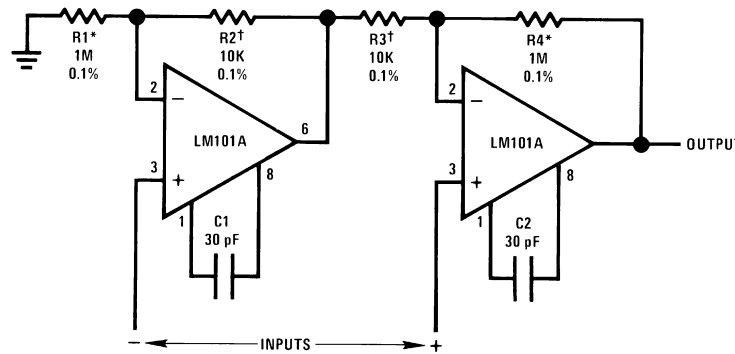

Figure 42. Fast AC/DC Converter⁽¹⁾



$$R1 = R4; R2 = R3$$

$$A_v = 1 + \frac{R1}{R2}$$

* † Matching determines CMRR.

Figure 43. Instrumentation Amplifier

(1) Feedforward compensation can be used to make a fast full wave rectifier without a filter

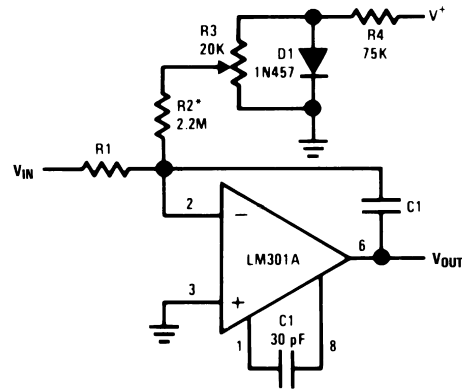

*Adjust for zero integrator drift. Current drift typically 0.1 nA/°C over 0°C to +70°C temperature range.

Figure 44. Integrator with Bias Current Compensation

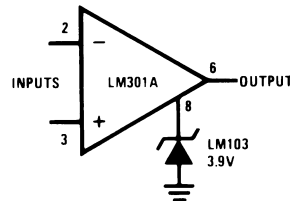

Figure 45. Voltage Comparator for Driving RTL Logic or High Current Driver

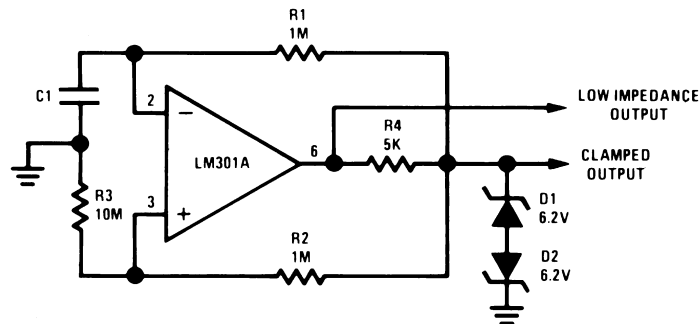
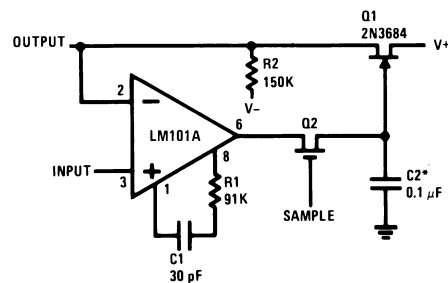

Figure 46. Low Frequency Square Wave Generator



*Polycarbonate-dielectric capacitor

Figure 47. Low Drift Sample and Hold

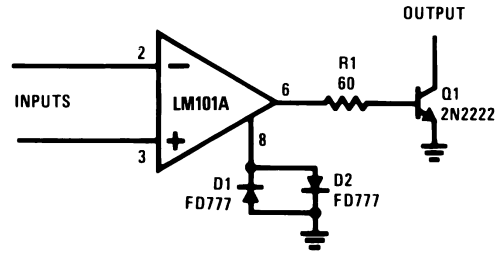
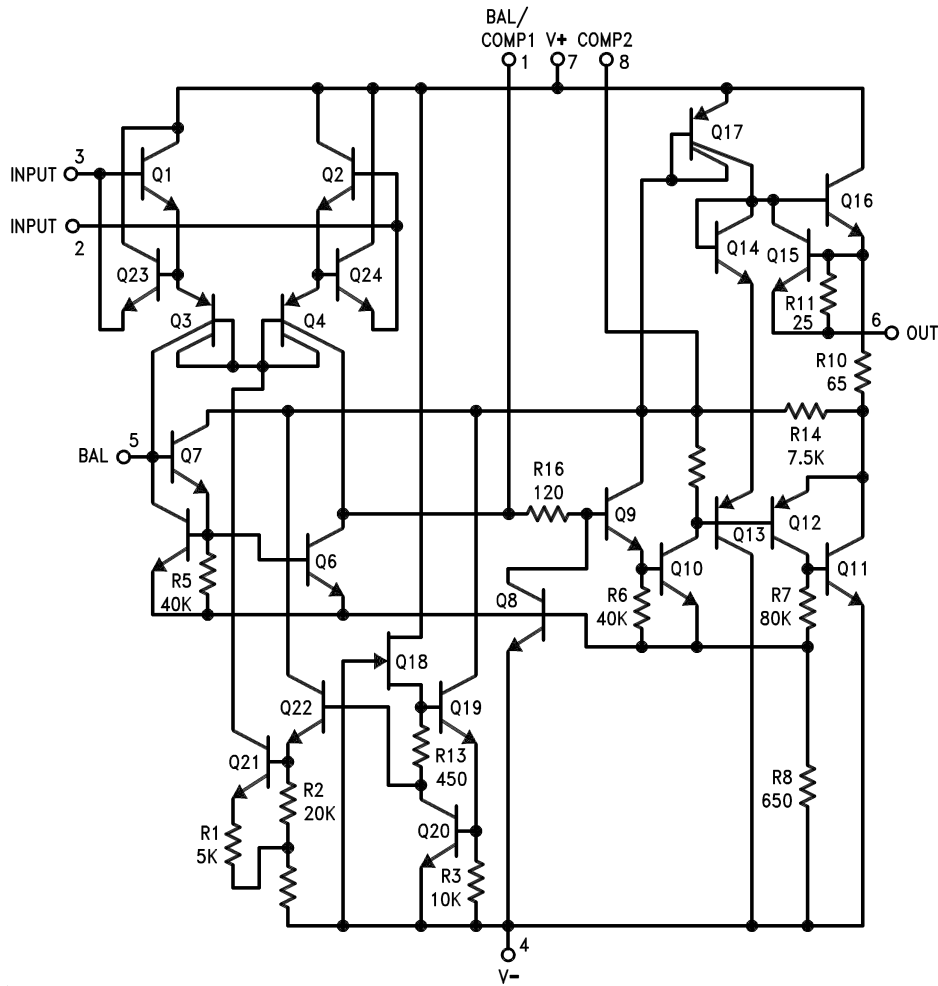

Figure 48. Voltage Comparator for Driving DTL or TTL Integrated Circuits

Schematic



Pin connections shown are for 8-pin packages.

Connection Diagrams

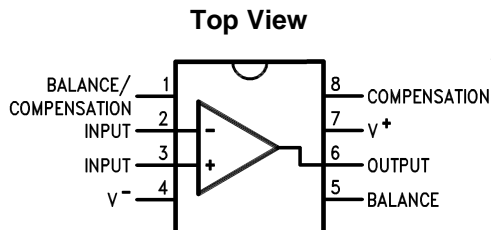

Figure 49. CDIP and PDIP Packages
Package Number NAB0008A or P0008E

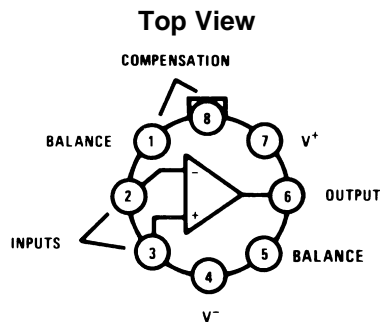

Figure 51. TO-99 Package
See Package Number LMC0008C

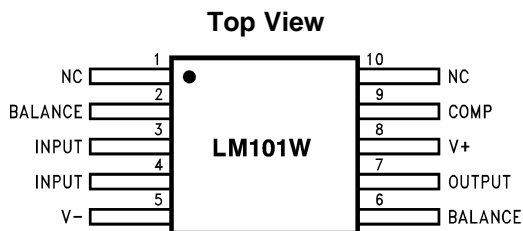

Figure 50. CLGA Package
Package Number NAD0010A

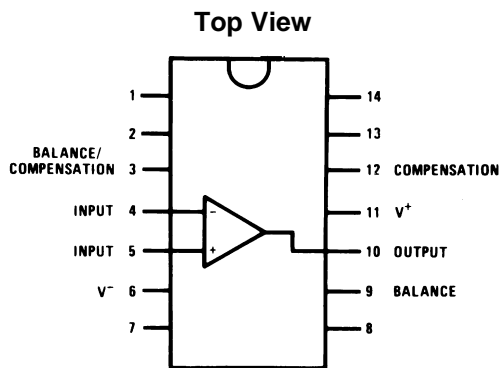

Figure 52. CDIP Package
See Package Number J0014A,

REVISION HISTORY

Changes from Revision C (March 2013) to Revision D

Page

-
- Changed layout of National Data Sheet to TI format [17](#)
-

PACKAGING INFORMATION

Orderable Device	Status (1)	Package Type	Package Drawing	Pins	Package Qty	Eco Plan (2)	Lead/Ball Finish (6)	MSL Peak Temp (3)	Op Temp (°C)	Device Marking (4/5)	Samples
LM101AH	ACTIVE	TO-99	LMC	8	500	TBD	Call TI	Call TI	-55 to 125	(LM101AH, LM101AH)	Samples
LM101AH/NOPB	ACTIVE	TO-99	LMC	8	500	Green (RoHS & no Sb/Br)	Call TI	Level-1-NA-UNLIM	-55 to 125	(LM101AH, LM101AH)	Samples
LM101AJ	ACTIVE	CDIP	NAB	8	40	TBD	Call TI	Call TI	-55 to 125	LM101AJ	Samples
LM201AH	ACTIVE	TO-99	LMC	8	500	TBD	Call TI	Call TI	-40 to 85	(LM201AH, LM201AH)	Samples
LM201AH/NOPB	ACTIVE	TO-99	LMC	8	500	Green (RoHS & no Sb/Br)	Call TI	Level-1-NA-UNLIM	-40 to 85	(LM201AH, LM201AH)	Samples
LM301AH	ACTIVE	TO-99	LMC	8	500	TBD	Call TI	Call TI	0 to 70	(LM301AH, LM301AH)	Samples
LM301AH/NOPB	ACTIVE	TO-99	LMC	8	500	Green (RoHS & no Sb/Br)	Call TI	Level-1-NA-UNLIM	0 to 70	(LM301AH, LM301AH)	Samples

(1) The marketing status values are defined as follows:

ACTIVE: Product device recommended for new designs.

LIFEBUY: TI has announced that the device will be discontinued, and a lifetime-buy period is in effect.

NRND: Not recommended for new designs. Device is in production to support existing customers, but TI does not recommend using this part in a new design.

PREVIEW: Device has been announced but is not in production. Samples may or may not be available.

OBSOLETE: TI has discontinued the production of the device.

(2) **RoHS:** TI defines "RoHS" to mean semiconductor products that are compliant with the current EU RoHS requirements for all 10 RoHS substances, including the requirement that RoHS substance do not exceed 0.1% by weight in homogeneous materials. Where designed to be soldered at high temperatures, "RoHS" products are suitable for use in specified lead-free processes. TI may reference these types of products as "Pb-Free".

RoHS Exempt: TI defines "RoHS Exempt" to mean products that contain lead but are compliant with EU RoHS pursuant to a specific EU RoHS exemption.

Green: TI defines "Green" to mean the content of Chlorine (Cl) and Bromine (Br) based flame retardants meet JS709B low halogen requirements of <=1000ppm threshold. Antimony trioxide based flame retardants must also meet the <=1000ppm threshold requirement.

(3) MSL, Peak Temp. - The Moisture Sensitivity Level rating according to the JEDEC industry standard classifications, and peak solder temperature.

(4) There may be additional marking, which relates to the logo, the lot trace code information, or the environmental category on the device.

(5) Multiple Device Markings will be inside parentheses. Only one Device Marking contained in parentheses and separated by a "~" will appear on a device. If a line is indented then it is a continuation of the previous line and the two combined represent the entire Device Marking for that device.

⁽⁶⁾ Lead/Ball Finish - Orderable Devices may have multiple material finish options. Finish options are separated by a vertical ruled line. Lead/Ball Finish values may wrap to two lines if the finish value exceeds the maximum column width.

Important Information and Disclaimer: The information provided on this page represents TI's knowledge and belief as of the date that it is provided. TI bases its knowledge and belief on information provided by third parties, and makes no representation or warranty as to the accuracy of such information. Efforts are underway to better integrate information from third parties. TI has taken and continues to take reasonable steps to provide representative and accurate information but may not have conducted destructive testing or chemical analysis on incoming materials and chemicals. TI and TI suppliers consider certain information to be proprietary, and thus CAS numbers and other limited information may not be available for release.

In no event shall TI's liability arising out of such information exceed the total purchase price of the TI part(s) at issue in this document sold by TI to Customer on an annual basis.

LMC (O-MBCY-W8)

METAL CYLINDRICAL PACKAGE

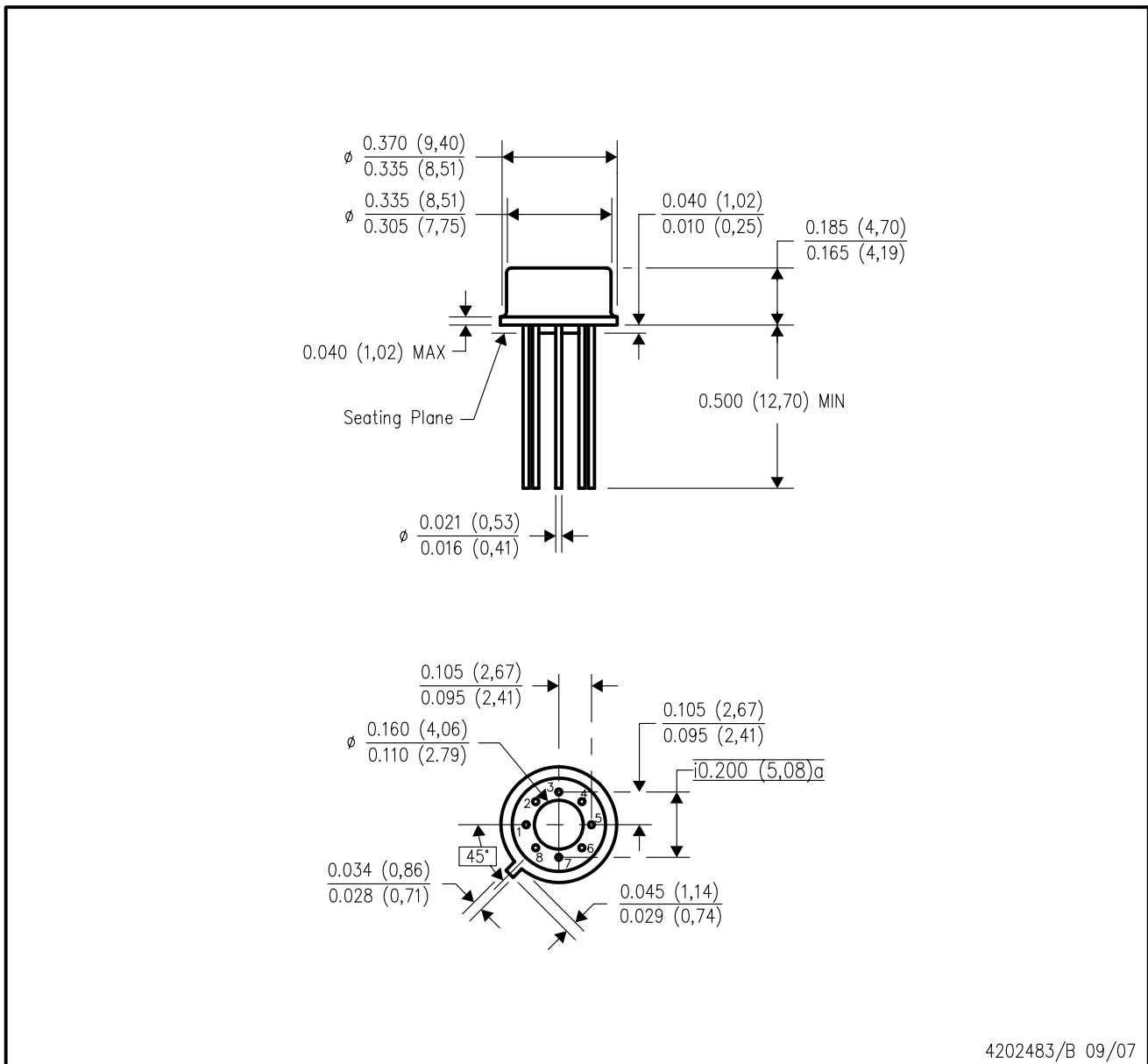

- NOTES:
- A. All linear dimensions are in inches (millimeters).
 - B. This drawing is subject to change without notice.
 - C. Leads in true position within 0.010 (0,25) R @ MMC at seating plane.
 - D. Pin numbers shown for reference only. Numbers may not be marked on package.
 - E. Falls within JEDEC MO-002/TO-99.

NAB0008A

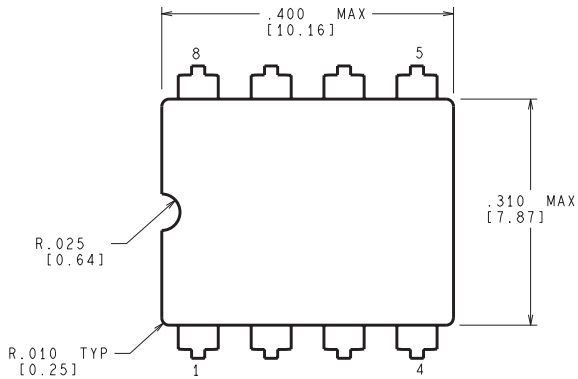

CONTROLLING DIMENSION IS INCH
VALUES IN [] ARE MILLIMETERS

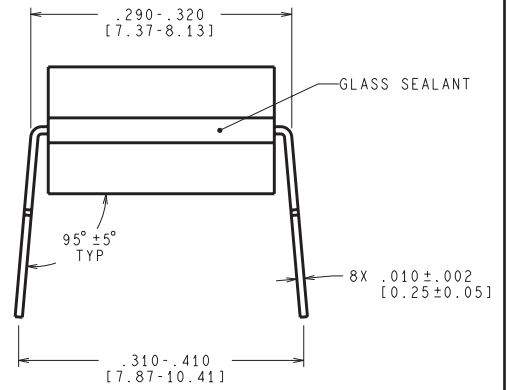
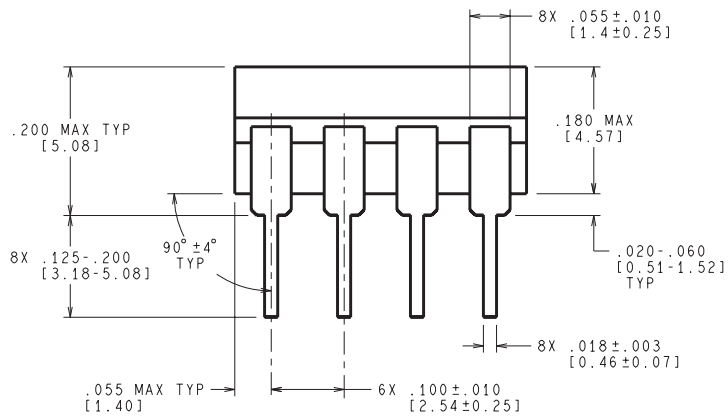

J08A (Rev M)

IMPORTANT NOTICE AND DISCLAIMER

TI PROVIDES TECHNICAL AND RELIABILITY DATA (INCLUDING DATASHEETS), DESIGN RESOURCES (INCLUDING REFERENCE DESIGNS), APPLICATION OR OTHER DESIGN ADVICE, WEB TOOLS, SAFETY INFORMATION, AND OTHER RESOURCES "AS IS" AND WITH ALL FAULTS, AND DISCLAIMS ALL WARRANTIES, EXPRESS AND IMPLIED, INCLUDING WITHOUT LIMITATION ANY IMPLIED WARRANTIES OF MERCHANTABILITY, FITNESS FOR A PARTICULAR PURPOSE OR NON-INFRINGEMENT OF THIRD PARTY INTELLECTUAL PROPERTY RIGHTS.

These resources are intended for skilled developers designing with TI products. You are solely responsible for (1) selecting the appropriate TI products for your application, (2) designing, validating and testing your application, and (3) ensuring your application meets applicable standards, and any other safety, security, or other requirements. These resources are subject to change without notice. TI grants you permission to use these resources only for development of an application that uses the TI products described in the resource. Other reproduction and display of these resources is prohibited. No license is granted to any other TI intellectual property right or to any third party intellectual property right. TI disclaims responsibility for, and you will fully indemnify TI and its representatives against, any claims, damages, costs, losses, and liabilities arising out of your use of these resources.

TI's products are provided subject to TI's Terms of Sale (www.ti.com/legal/termsofsale.html) or other applicable terms available either on ti.com or provided in conjunction with such TI products. TI's provision of these resources does not expand or otherwise alter TI's applicable warranties or warranty disclaimers for TI products.

Mailing Address: Texas Instruments, Post Office Box 655303, Dallas, Texas 75265
Copyright © 2019, Texas Instruments Incorporated

Looking for pricing, stock, or lifecycle information?

Click below to explore more details on WIN SOURCE:

 [View LM101AJ](#) on WIN SOURCE

 [Texas Instruments](#) Information

Optimize Your Supply Chain with WIN SOURCE Solutions

-  Global Sourcing Solution
-  Obsolete Management
-  Cost Control Management
-  Shortage Management
-  Alternative Solution
-  Excess Inventory Management