

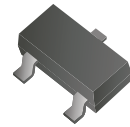

**THE DATASHEET OF  
MMBT3906-G**



## MMBT3906-G (PNP) RoHS Device



### Features

- Epitaxial planar die construction
- As complementary type, the NPN transistor MMBT3904-G is recommended

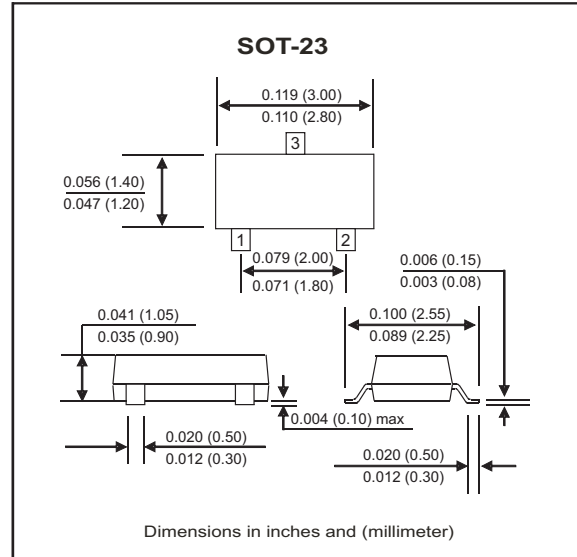
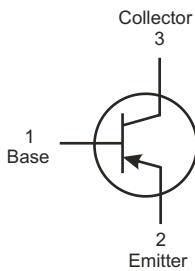

### Maximum Ratings (at TA=25°C unless otherwise noted)

Parameter	Symbol	Min	Typ	Max	Unit
Collector-Base voltage	V <sub>CB0</sub>			-40	V
Collector-Emitter voltage	V <sub>CE0</sub>			-40	V
Emitter-Base voltage	V <sub>EB0</sub>			-5	V
Collector current-Continuous	I <sub>C</sub>			-0.2	A
Collector dissipation	P <sub>C</sub>			0.2	W
Storage temperature and junction temperature	T <sub>STG</sub> , T <sub>J</sub>	-55		+150	°C

### Electrical Characteristics (at TA=25°C unless otherwise noted)

Parameter	Conditions	Symbol	Min	Max	Unit
Collector-Base breakdown voltage	I <sub>C</sub> = -100μA , I <sub>E</sub> = 0	V <sub>(BR)CB0</sub>	-40		V
Collector-Emitter breakdown voltage	I <sub>C</sub> = -1mA , I <sub>B</sub> = 0	V <sub>(BR)CE0</sub>	-40		V
Emitter-Base breakdown voltage	I <sub>E</sub> = -100μA , I <sub>C</sub> = 0	V <sub>(BR)EB0</sub>	-5		V
Collector cut-off current	V <sub>CB</sub> = -40V , I <sub>E</sub> = 0	I <sub>CB0</sub>		-0.1	μA
Collector cut-off current	V <sub>CE</sub> = -40V , I <sub>B</sub> = 0	I <sub>CE0</sub>		-0.1	μA
Emitter cut-off current	V <sub>EB</sub> = -5V , I <sub>C</sub> = 0	I <sub>EB0</sub>		-0.1	μA
DC current gain	V <sub>CE</sub> = -1V , I <sub>C</sub> = -10mA	h <sub>FE(1)</sub>	100	300	
	V <sub>CE</sub> = -1V , I <sub>C</sub> = -50mA	h <sub>FE(2)</sub>	60		
	V <sub>CE</sub> = -1V , I <sub>C</sub> = -100mA	h <sub>FE(3)</sub>	30		
Collector-Emitter saturation voltage	I <sub>C</sub> = -50mA , I <sub>B</sub> = -5mA	V <sub>CE(sat)</sub>		-0.4	V
Base-Emitter saturation voltage	I <sub>C</sub> = -50mA , I <sub>B</sub> = -5mA	V <sub>BE(sat)</sub>		-0.95	V
Transition frequency	V <sub>CE</sub> = -20V , I <sub>C</sub> = -10mA f = 100MHz	f <sub>T</sub>	300		Mhz
Delay time	V <sub>CC</sub> = -3.0V , V <sub>BE</sub> = -0.5V	t <sub>d</sub>		35	nS
Rise time	I <sub>C</sub> = -10mA , I <sub>B1</sub> = -1.0mA	t <sub>r</sub>		35	nS
Storage time	V <sub>CC</sub> = -3.0V <sub>dc</sub> , I <sub>C</sub> = -10mA	t <sub>s</sub>		225	nS
Fall time	I <sub>B1</sub> = I <sub>B2</sub> = -1.0mA	t <sub>f</sub>		75	nS

## RATING AND CHARACTERISTIC CURVES (MMBT3906-G)

Fig.1 - Static Characteristic

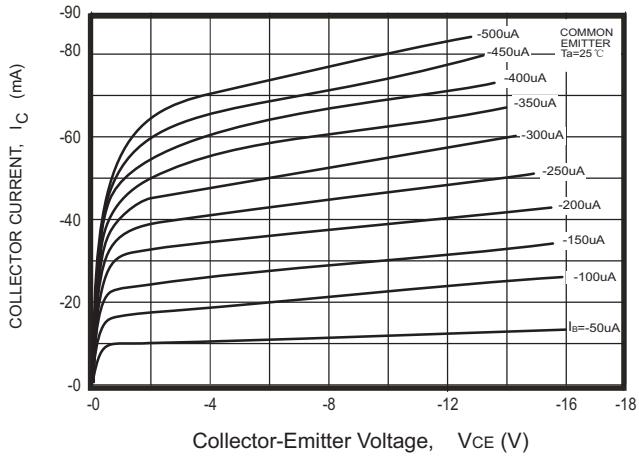

Fig.2 -  $h_{FE} - I_C$

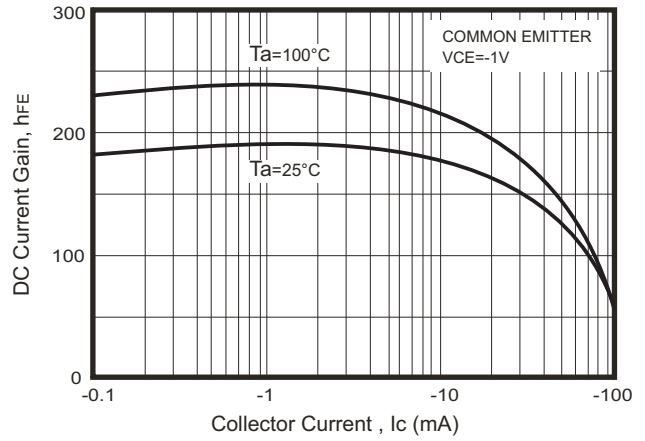

Fig.3 -  $V_{CEsat} - I_C$

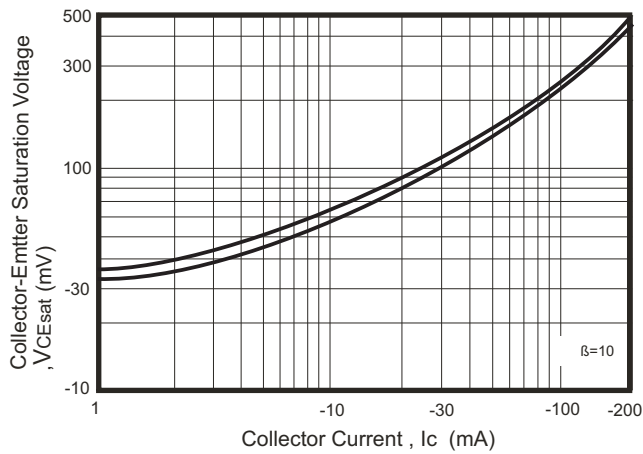

Fig.4 -  $V_{BEsat} - I_C$

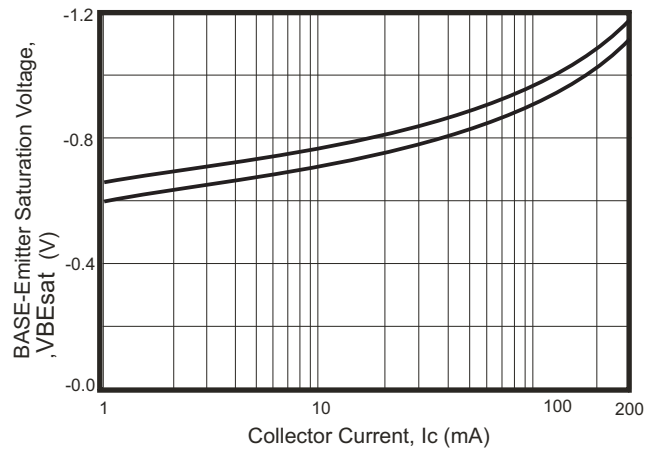

Fig.5 -  $I_C - V_{BE}$

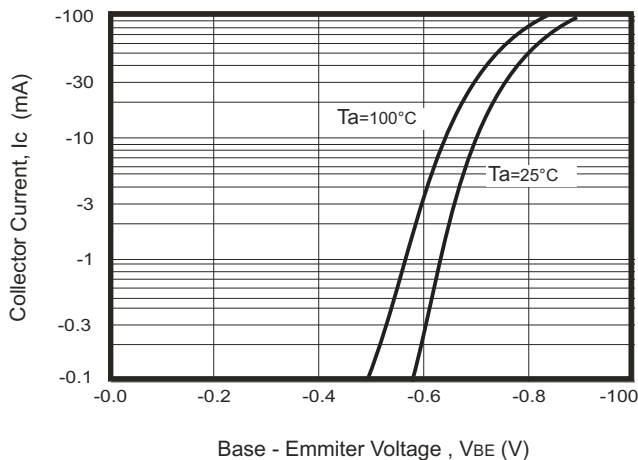
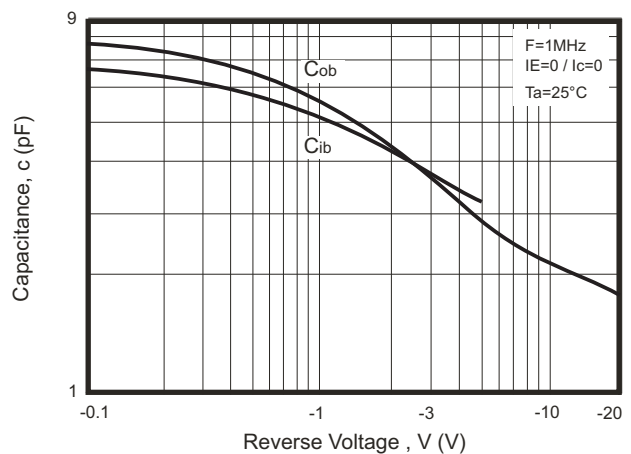

Fig.6 -  $C_{ob}/C_{ib} - V_{CB}/V_{EB}$



## RATING AND CHARACTERISTIC CURVES (MMBT3906-G)

Fig.7 -  $f_T$  —  $I_C$

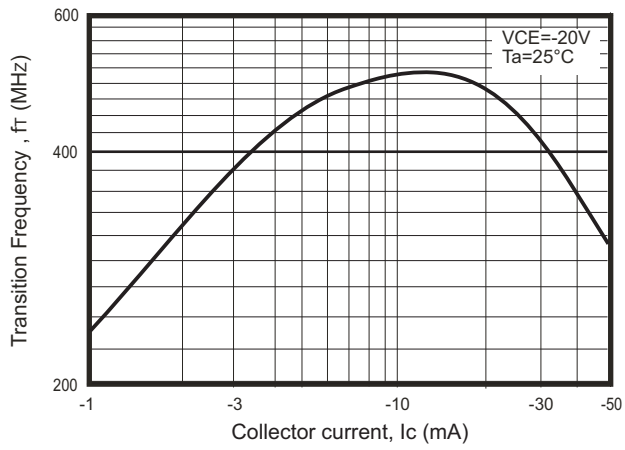
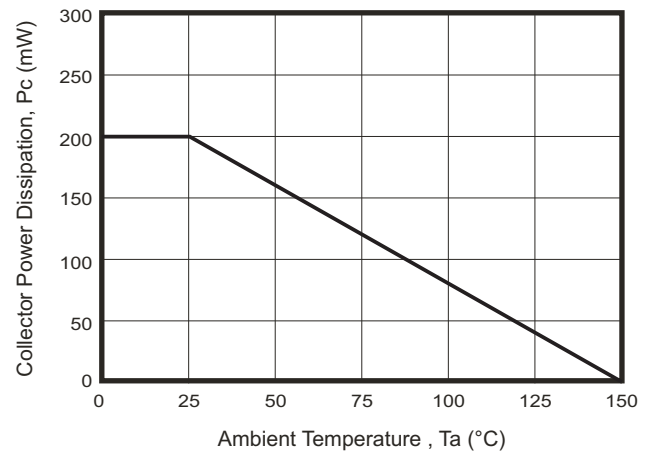
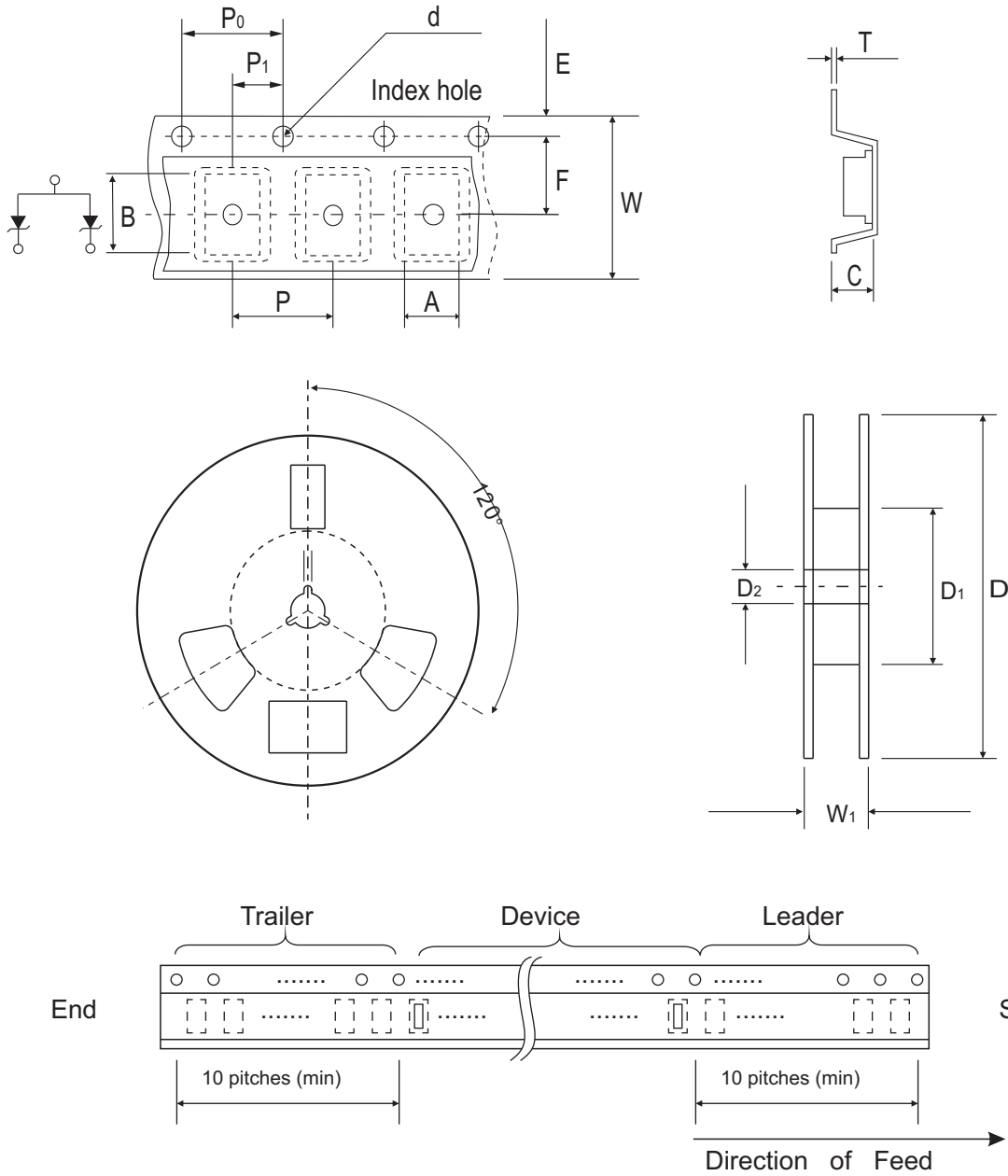

Fig.8 -  $P_C$  —  $T_a$



## Reel Taping Specification



SOT-23	SYMBOL	A	B	C	d	D	D1	D2
	(mm)	3.15 ± 0.10	2.77 ± 0.10	1.22 ± 0.10	1.50 ± 0.10	178 ± 1.00	54.40 ± 0.40	13.00 ± 0.20
	(inch)	0.124 ± 0.004	0.109 ± 0.004	0.048 ± 0.004	0.059 ± 0.004	7.008 ± 0.039	2.142 ± 0.016	0.512 ± 0.008

SOT-23	SYMBOL	E	F	P	P0	P1	W	W1
	(mm)	1.75 ± 0.10	3.50 ± 0.05	4.00 ± 0.10	4.00 ± 0.10	2.00 ± 0.10	8.00 + 0.30 / - 0.10	9.50 ± 1.00
	(inch)	0.069 ± 0.004	0.138 ± 0.002	0.157 ± 0.004	0.157 ± 0.004	0.079 ± 0.004	0.315 + 0.012 / - 0.004	0.374 ± 0.039

## Marking Code

Code: Per A. D.

Part Number	Marking Code
MMBT3906-G	2A

Year(odd)-Month	Code	Year(Even)-Month	Code
XXX1-01	J	XXX2-01	W
XXX1-02	O	XXX2-02	N
XXX1-03	L	XXX2-03	Y
XXX1-04	C	XXX2-04	T
XXX1-05	K	XXX2-05	R
XXX1-06	B	XXX2-06	H
XXX1-07	P	XXX2-07	A
XXX1-08	D	XXX2-08	I
XXX1-09	M	XXX2-09	U
XXX1-010	E	XXX2-010	X
XXX1-011	G	XXX2-011	Z
XXX1-012	F	XXX2-012	S

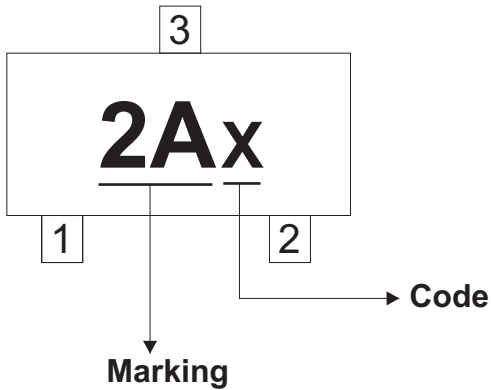

## Suggested PAD Layout

SIZE	SOT-23	
	(mm)	(inch)
A	0.80	0.031
B	1.90	0.075
C	2.02	0.080
D	2.82	0.111

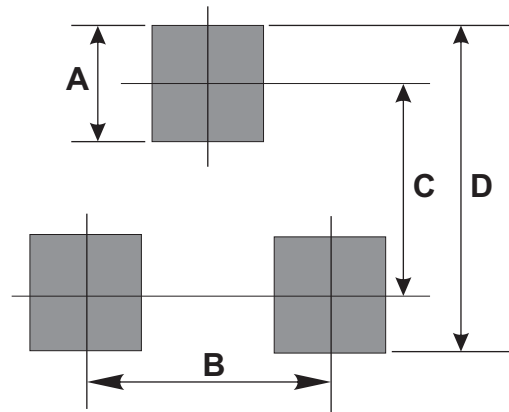

## Standard Packaging

Case Type	REEL PACK	
	REEL ( pcs )	Reel Size (inch)
SOT-23	3,000	7

## Looking for pricing, stock, or lifecycle information?

Click below to explore more details on WIN SOURCE:

- [View MMBT3906-G on WIN SOURCE](#)
- [Comchip Technology Information](#)

## Optimize Your Supply Chain with WIN SOURCE Solutions

- ✓ Global Sourcing Solution
- ✓ Obsolete Management
- ✓ Cost Control Management
- ✓ Shortage Management
- ✓ Alternative Solution
- ✓ Excess Inventory Management