



THE DATASHEET OF CY25560SXIT



Spread Spectrum Clock Generator

Features

- 25 MHz to 100 MHz operating frequency range
- Nine different spread select options
- Accepts clock and crystal inputs
- Low power dissipation:
 - 56 mW at Fin = 25 MHz
 - 89 mW at Fin = 65 MHz
 - 139 mW at Fin = 100 MHz
- Frequency spread disable function
- Center spread modulation
- Low cycle-to-cycle jitter
- 8-pin SOIC package
- Commercial and industrial temperature ranges

Applications

- Desktop, notebook, and tablet PCs
- VGA controllers
- LCD panels and monitors
- Printers and multifunction devices (MFP)

Benefits

- Peak electromagnetic interference (EMI) reduction by 8 to 16 dB
- Fast time to market
- Cost reduction

Functional Description

For a complete list of related documentation, click [here](#).

Logic Block Diagram

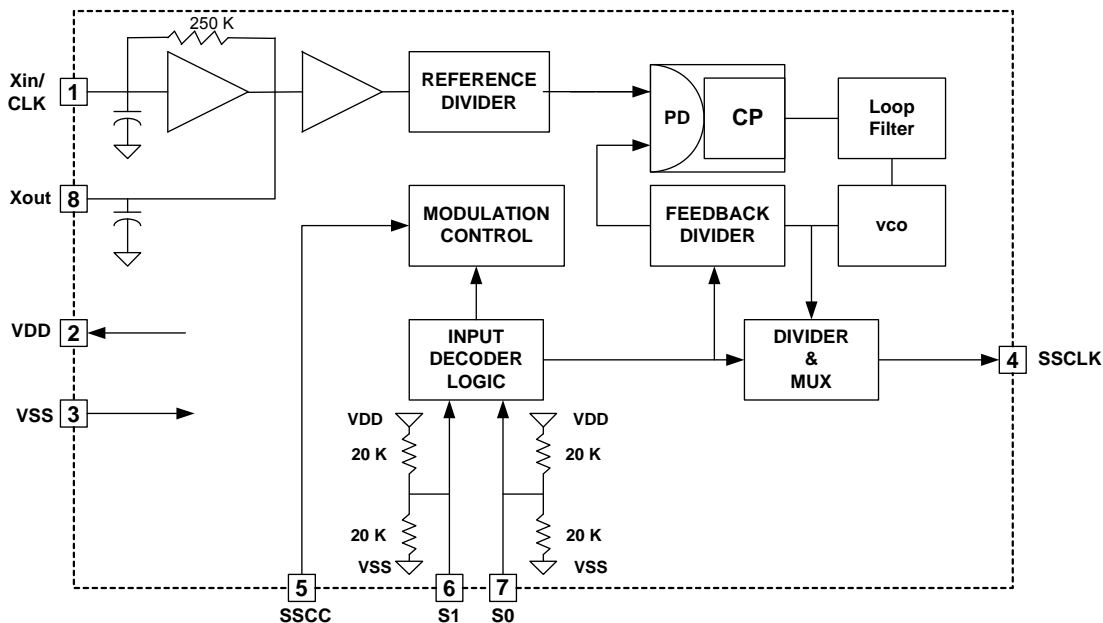

Contents

Pinouts	3	DC Electrical Characteristics	8
Pin Description	3	Electrical Timing Characteristics	8
General Description	3	Thermal Resistance	8
Frequency and Spread% Selection		Ordering Information	9
(Center Spread)	4	Ordering Code Definitions	9
Tri-Level Logic	4	Package Drawing and Dimensions	10
SSCG Theory of Operation	4	Acronyms	11
EMI	4	Document Conventions	11
SSCG	5	Units of Measure	11
Modulation Rate	5	Document History Page	12
CY25560 Application Schematic	6	Sales, Solutions, and Legal Information	13
Absolute Maximum Ratings	7	Worldwide Sales and Design Support	13
DC Electrical Characteristics	7	Products	13
XIN/CLK DC Specifications	7	PSoC@Solutions	13
Electrical Timing Characteristics	7	Cypress Developer Community	13
Absolute Maximum Conditions	8	Technical Support	13

Pinouts

Figure 1. 8-pin SOIC pinout

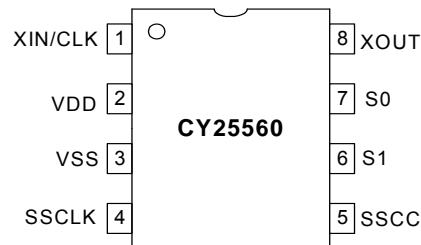

Pin Description

Pin Number	Pin Name	Type	Pin Description
1	Xin/CLK	I	Clock or crystal connection input. See the Table on page 4 for input frequency range selection.
2	VDD	P	Positive power supply.
3	GND	P	Power supply ground.
4	SSCLK	O	Modulated clock output, that is the same frequency as the input clock or the crystal frequency.
5	SSCC	I	Spread spectrum clock control (enable/disable) function. SSCG function is enabled when input is high and disabled when input is low. This pin is pulled high internally.
6	S1	I	Tri-level logic input control pin used to select input frequency range and spread percent. See the Tri-Level Logic on page 4 for programming details. Pin 6 has an internal resistor divider network to V _{DD} and V _{SS} . See the Logic Block Diagram on page 1 .
7	S0	I	Tri-level logic input control pin used to select input frequency range and spread percent. See the Tri-Level Logic on page 4 for programming details. Pin 7 has an internal resistor divider network to V _{DD} and V _{SS} . See the Logic Block Diagram on page 1 .
8	Xout	O	Oscillator output pin connected to crystal. Leave this pin unconnected if an external clock is used to drive xin/clk input (Pin 1).

General Description

The Cypress CY25560 is a spread spectrum clock generator (SSCG) IC used to reduce the EMI found in today's high-speed digital electronic systems.

The CY25560 uses Cypress's proprietary phase-locked loop (PLL) and spread spectrum clock (SSC) technology to synthesize and frequency modulate the input frequency of the reference clock. By frequency modulating the clock, the measured EMI at the fundamental and harmonic frequencies of clock (SSCLK) is greatly reduced.

This reduction in radiated energy can significantly reduce the cost of complying with regulatory requirements and time to market without degrading system performance.

The CY25560 is a very simple and versatile device to use. The frequency and spread% range is selected by programming S0 and S1 digital inputs. These inputs use three (3) logic states including High (H), Low (L), and Middle (M) logic levels to select

one of the nine available spread% ranges. See the [Frequency and Spread% Selection \(Center Spread\) on page 4](#) for programming details.

CY25560 is optimized for SVGA (40 MHz) and XVGA (65 MHz) controller clocks and also suitable for applications where the frequency range is 25 MHz to 100 MHz.

A wide range of digitally selectable spread percentages is made possible by using three-level (High, Low, and Middle) logic at the S0 and S1 digital control inputs.

The output spread (frequency modulation) is symmetrically centered on the input frequency.

Spread spectrum clock control (SSCC) function enables or disables the frequency spread and is provided for easy comparison of system performance during EMI testing.

The CY25560 is available in an 8-pin SOIC package with 0 °C to 70 °C Commercial and -40 °C to 85 °C Industrial operating temperature ranges.

Frequency and Spread% Selection (Center Spread)

25 – 50 MHz (Low Range)

Input Frequency (MHz)	S1=M S0=M (%)	S1=M S0=0 (%)	S1=1 S0=0 (%)	S1=0 S0=0 (%)	S1=0 S0=M (%)
25 – 35	4.3	3.8	3.4	2.9	2.8
35 – 40	3.9	3.5	3.1	2.5	2.4
40 – 45	3.7	3.3	2.8	2.4	2.3
45 – 50	3.4	3.1	2.6	2.2	2.1

Select the Frequency and Center Spread % desired and then set S1, S0 as indicated.

50 – 100 MHz (High Range)

Input Frequency (MHz)	S1=1 S0=M (%)	S1=0 S0=1 (%)	S1=1 S0=1 (%)	S1=M S0=1 (%)
50 – 60	2.9	2.1	1.5	1.2
60 – 70	2.8	2.0	1.4	1.1
70 – 80	2.6	1.8	1.3	1.1
80 – 100	2.4	1.7	1.2	1.0

Select the Frequency and Center Spread % desired and then set S1, S0 as indicated.

Tri-Level Logic

With binary logic, four states can be programmed with two control lines, whereas three-level logic can program nine logic states using two control lines. Three-level logic in the CY25560 is implemented by defining a third logic state in addition to the standard logic '1' and '0'. Pins 6 and 7 of the CY25560 recognize a logic state by the voltage applied to their respective pin. These states are defined as '0' (Low), 'M' (Middle), and '1' (One). Each

of these states have a defined voltage range that is interpreted by the CY25560 as a '0', 'M', or '1' logic state. See the [DC Electrical Characteristics on page 7](#) for voltage ranges for each logic state. The CY25560 has two equal value resistor dividers connected internally to Pins 6 and 7 that produce the default 'M' (Middle) state if these pins are left unconnected (NC). Pins 6 and/or 7 can be tied directly to ground or V_{DD} to program a logic '0' or '1' state, respectively.

Figure 2. Three-Level Logic Examples

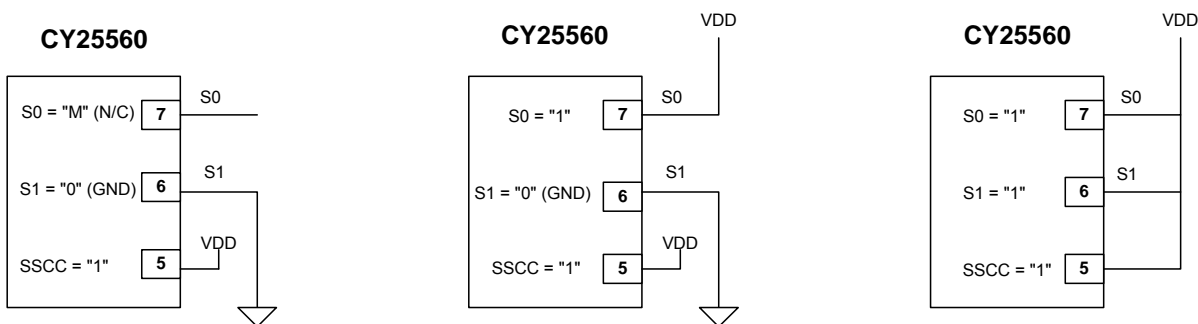

SSCG Theory of Operation

The CY25560 is a PLL-type clock generator using a proprietary Cypress design. By precisely controlling the bandwidth of the output clock, the CY25560 becomes a low-EMI clock generator. The theory and detailed operation of the CY25560 is discussed in the following sections.

EMI

All digital clocks generate unwanted energy in their harmonics. Conventional digital clocks are square waves with a duty cycle that is very close to 50 percent. Because of this 50/50 duty cycle, digital clocks generate most of their harmonic energy in the odd harmonics, i.e., third, fifth, seventh, and so on. It is possible to reduce the amount of energy contained in the fundamental and odd harmonics by increasing the bandwidth of the fundamental clock frequency. Conventional digital clocks have a very high Q factor, that means that all of the energy at that frequency is

concentrated in a very narrow bandwidth, consequently, higher energy peaks. Regulatory agencies test electronic equipment by the amount of peak energy radiated from the equipment. By reducing the peak energy at the fundamental and harmonic frequencies, the equipment under test is able to satisfy agency requirements for EMI. Conventional methods of reducing EMI have been to use shielding, filtering, multilayer PCBs, and so on. The CY25560 uses the approach of reducing the peak energy in the clock by increasing the clock bandwidth, and lowering the Q factor.

SSCG

SSCG uses a patented technology of modulating the clock over a very narrow bandwidth and controlled rate of change, both peak and cycle-to-cycle. The CY25560 takes a narrow band digital reference clock in the range of 25 to 100 MHz and produces a clock that sweeps between a controlled start and stop frequency and precise rate of change. To understand what happens to a clock when SSCG is applied, consider a 65 MHz clock with a 50 percent duty cycle. From a 65 MHz clock we know the following:

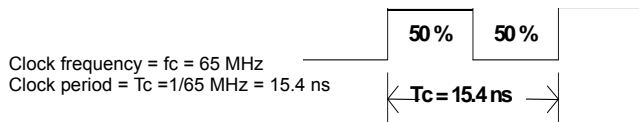

If this clock is applied to the Xin/CLK pin of CY25560, the output clock at Pin 4 (SSCLK) sweeps back and forth between two frequencies. These two frequencies, F1 and F2, are used to

calculate to total amount of spread or bandwidth applied to the reference clock at Pin 1. As the clock is making the transition from F1 to F2, the amount of time and sweep waveform play a very important role in the amount of EMI reduction realized from an SSCG clock.

The modulation domain analyzer is used to visualize the sweep waveform and sweep period. Figure 3 shows the modulation profile of a 65 MHz SSCG clock. Notice that the actual sweep waveform is not a simple sine or sawtooth waveform. Figure 3 also shows a scan of the same SSCG clock using a spectrum analyzer. In this scan you can see a 6.48 dB reduction in the peak RF energy when using the SSCG clock.

Modulation Rate

SSCGs utilize frequency modulation (FM) to distribute energy over a specific band of frequencies. The maximum frequency of the clock (Fmax) and minimum frequency of the clock (Fmin) determine this band of frequencies. The time required to transition from Fmin to Fmax and back to Fmin is the period of the Modulation Rate, Tmod. Modulation Rates of SSCG clocks are generally referred to in terms of frequency or $F_{mod} = 1/T_{mod}$.

The input clock frequency, Fin, and the internal divider count, Cdiv, determine the Modulation Rate. In some SSCG clock generators, the selected range determines the internal divider count. In other SSCG clocks, the internal divider count is fixed over the operating range of the device. The CY25560 has a fixed divider count of 1166.

Figure 3. SSCG Clock, CY25560, Fin = 65 MHz

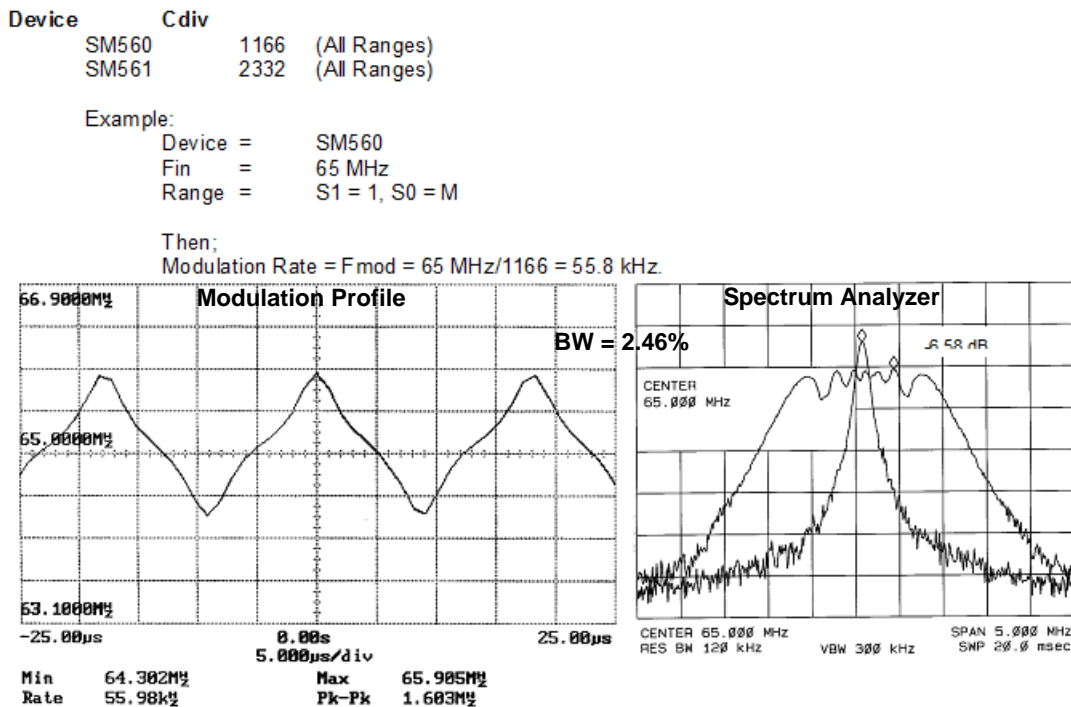

CY25560 Application Schematic

The schematic in [Figure 4](#) demonstrates how the CY25560 is configured in a typical application. This application is shown as using a 30 MHz fundamental crystal. In most applications, an external reference clock is used. Apply the external clock signal at Xin (Pin 1) and leave Xout (Pin 8) unconnected (see [Pin Description on page 3](#) for pin descriptions).

Contact Cypress if higher order crystal is to be used.

Figure 4. Application Schematic

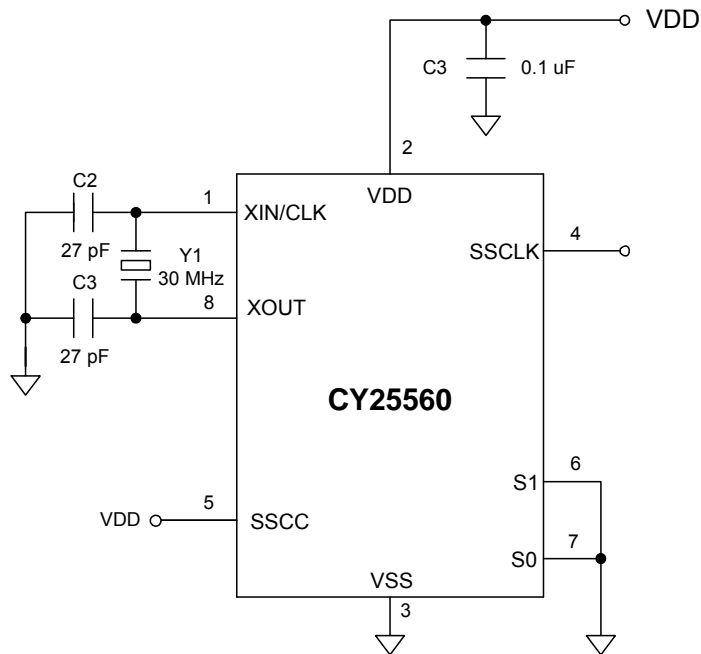

Absolute Maximum Ratings

Commercial Grade [1, 2]

Supply Voltage (V_{DD}) -0.5 V to +6.0 V

DC Input Voltage -0.5 V to $V_{DD} + 0.5$ V

Junction Temperature -40 °C to +140 °C

Operating Temperature 0 °C to 70 °C

Storage Temperature -65 °C to +150 °C

Static Discharge Voltage (ESD) 2,000 V-Min

DC Electrical Characteristics

$V_{DD} = 3.3$ V \pm 10%, $T = 0$ °C to 70 °C and C_L (Pin 4) = 15 pF, Unless Otherwise Noted

Parameter	Description	Conditions	Min	Typ	Max	Unit
V_{DD}	Power supply range	$\pm 10\%$	2.97	3.3	3.63	V
V_{IH}	Input high voltage	S0 and S1 only	$0.85 \times V_{DD}$	V_{DD}	V_{DD}	V
V_{IM}	Input middle voltage	S0 and S1 only	$0.40 \times V_{DD}$	$0.50 \times V_{DD}$	$0.60 \times V_{DD}$	V
V_{IL}	Input low voltage	S0 and S1 only	0.0	0.0	$0.15 \times V_{DD}$	V
V_{OH}	Output high voltage	$I_{OH} = 6$ mA	2.4	–	–	V
V_{OL}	Output low voltage	$I_{OH} = 6$ mA	–	–	0.4	V
C_{in1}	Input capacitance	Xin/CLK (Pin 1)	3	4	5	pF
C_{in2}	Input capacitance	Xout (Pin 8)	6	8	10	pF
C_{in2}	Input capacitance	S0, S1, SSCC (Pins 7, 6, 5)	3	4	5	pF
I_{DD1}	Power supply current	FIN = 25 MHz, CL = 0	–	17	23	mA
I_{DD2}	Power supply current	FIN = 65 MHz, CL = 0	–	27	41	mA
I_{DD3}	Power supply current	FIN = 100 MHz, CL = 0	–	42	59	mA

X_{IN} /CLK DC Specifications

Parameter	Description	Conditions	Min	Max	Units
$V_{IH(X)}$	Input high voltage, X_{IN} Clock Input	$F \leq 100$ MHz	80	–	% of V_{DD}
$V_{IL(X)}$	Input low voltage, X_{IN} Clock Input		–	15	% of V_{DD}

Electrical Timing Characteristics

$V_{DD} = 3.3$ V \pm 10%, $T = 0$ °C to 70 °C and C_L (Pin 4) = 15 pF, Unless Otherwise Noted

Parameter	Description	Conditions	Min	Typ	Max	Unit
f_{CLKFR}	Input clock frequency range	$V_{DD} = 3.30$ V	25	–	100	MHz
t_F	Clock rise time (Pin 4)	SSCLK at 0.4 V–2.4 V	1.0	1.8	2.8	ns
t_R	Clock fall time (Pin 4)	SSCLK at 0.4 V–2.4 V	1.0	1.8	2.8	ns
D_{TYin}	Input clock duty cycle	XIN/CLK (Pin 1)	25	50	75	%
D_{TYout}	Output clock duty cycle	SSCLK (Pin 4)	45	50	55	%
J_{CC1}	Cycle-to-cycle jitter	Fin = 25 MHz–50 MHz, SSCC = 1	–	150	300	ps
J_{CC2}	Cycle-to-cycle jitter	Fin = 50 MHz–100 MHz, SSCC = 1	–	130	200	ps

Notes

1. Operation at any Absolute Maximum Rating is not implied.
2. Single Power Supply: The voltage on any input or I/O pin cannot exceed the power pin during power-up.

Absolute Maximum Conditions

Industrial Grade [3, 4]

Supply Voltage (V_{DD})-0.5 V to +6.0 V

DC Input Voltage-0.5 V to V_{DD}+0.5 V

Junction Temperature -40 °C to +140 °C

Operating Temperature -40 °C to 85 °C

Storage Temperature -65 °C to +150 °C

Static Discharge Voltage (ESD) 2,000 V-Min

DC Electrical Characteristics

V_{DD} = 3.3 V ± 10%, T= -40 °C to 85 °C and C_L (Pin 4) = 15 pF, Unless Otherwise Noted

Parameter	Description	Conditions	Min	Typ	Max	Unit
V _{DD}	Power supply range	±10%	2.97	3.3	3.63	V
V _{IH}	Input high voltage	S0 and S1 only	0.85 × V _{DD}	V _{DD}	V _{DD}	V
V _{IM}	Input middle voltage	S0 and S1 only	0.40 × V _{DD}	0.50 × V _{DD}	0.60 × V _{DD}	V
V _{IL}	Input low voltage	S0 and S1 only	0.0	0.0	0.15 × V _{DD}	V
V _{OH}	Output high voltage	I _{OH} = 6 mA	2.2	–	–	V
V _{OL}	Output low voltage	I _{OH} = 6 mA	–	–	0.4	V
C _{in1}	Input capacitance	Xin/CLK (Pin 1)	3	4	5	pF
C _{in2}	Input capacitance	Xout (Pin 8)	6	8	10	pF
C _{in2}	Input capacitance	S0, S1, SSCC (Pins 7, 6, 5)	3	4	5	pF
I _{DD1}	Power supply current	FIN = 25 MHz, CL= 0	–	17	24	mA
I _{DD2}	Power supply current	FIN = 65 MHz, CL= 0	–	27	41	mA
I _{DD3}	Power supply current	FIN = 100 MHz, CL= 0	–	42	61	mA

Electrical Timing Characteristics

V_{DD} = 3.3 V ± 10%, T= -40 °C to 85 °C and C_L (Pin 4) = 15 pF, Unless Otherwise Noted

Parameter	Description	Conditions	Min	Typ	Max	Unit
I _{CLKFR}	Input clock frequency range	V _{DD} = 3.30 V	25	–	100	MHz
t _F	Clock rise time (Pin 4)	SSCLK at 0.4 V–2.4 V	1.0	1.8	3.0	ns
t _R	Clock fall time (Pin 4)	SSCLK at 0.4 V–2.4 V	1.0	1.8	3.0	ns
D _{TYin}	Input clock duty cycle	XIN/CLK (Pin 1)	25	50	75	%
D _{TYout}	Output clock duty cycle	SSCLK (Pin 4)	45	50	55	%
J _{CC1}	Cycle-to-cycle jitter	Fin = 25 MHz–50 MHz, SSCC = 1	–	150	300	ps
J _{CC2}	Cycle-to-cycle jitter	Fin = 50 MHz–100 MHz, SSCC = 1	–	130	200	ps

Thermal Resistance

Parameter [5]	Description	Test Conditions	8-pin SOIC	Unit
θ _{JA}	Thermal resistance (junction to ambient)	Test conditions follow standard test methods and procedures for measuring thermal impedance, in accordance with EIA/JESD51.	131	°C/W
θ _{JC}	Thermal resistance (junction to case)		41	°C/W

Notes

- 3. Operation at any Absolute Maximum Rating is not implied.
- 4. Single Power Supply: The voltage on any input or I/O pin cannot exceed the power pin during power-up.
- 5. These parameters are guaranteed by design and are not tested.

Ordering Information

Part Number	Package Type	Product Flow
Pb-free		
CY25560SXC	8-pin SOIC	Commercial, 0 °C to 70 °C
CY25560SXCT	8-pin SOIC – Tape and Reel	Commercial, 0 °C to 70 °C
CY25560SXI	8-pin SOIC	Industrial, –40 °C to 85 °C
CY25560SXIT	8-pin SOIC – Tape and Reel	Industrial, –40 °C to 85 °C

Ordering Code Definitions

CY 25560 S X X X

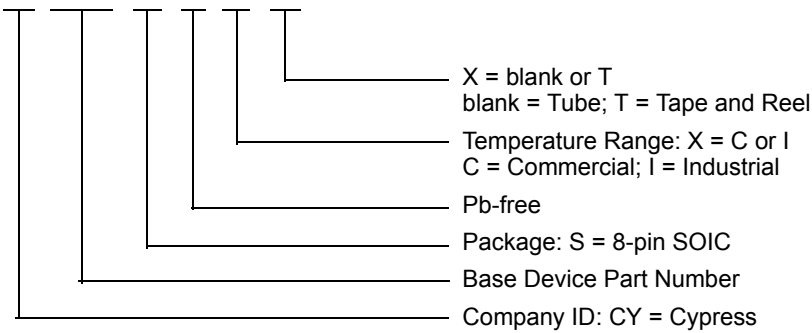

Package Drawing and Dimensions

Figure 5. 8-pin SOIC (150 Mils) S0815/SZ815/SW815 Package Outline, 51-85066

1. DIMENSIONS IN INCHES[MM] MIN. MAX.
2. PIN 1 ID IS OPTIONAL.
ROUND ON SINGLE LEADFRAME
RECTANGULAR ON MATRIX LEADFRAME
3. REFERENCE JEDEC MS-012
4. PACKAGE WEIGHT 0.07gms

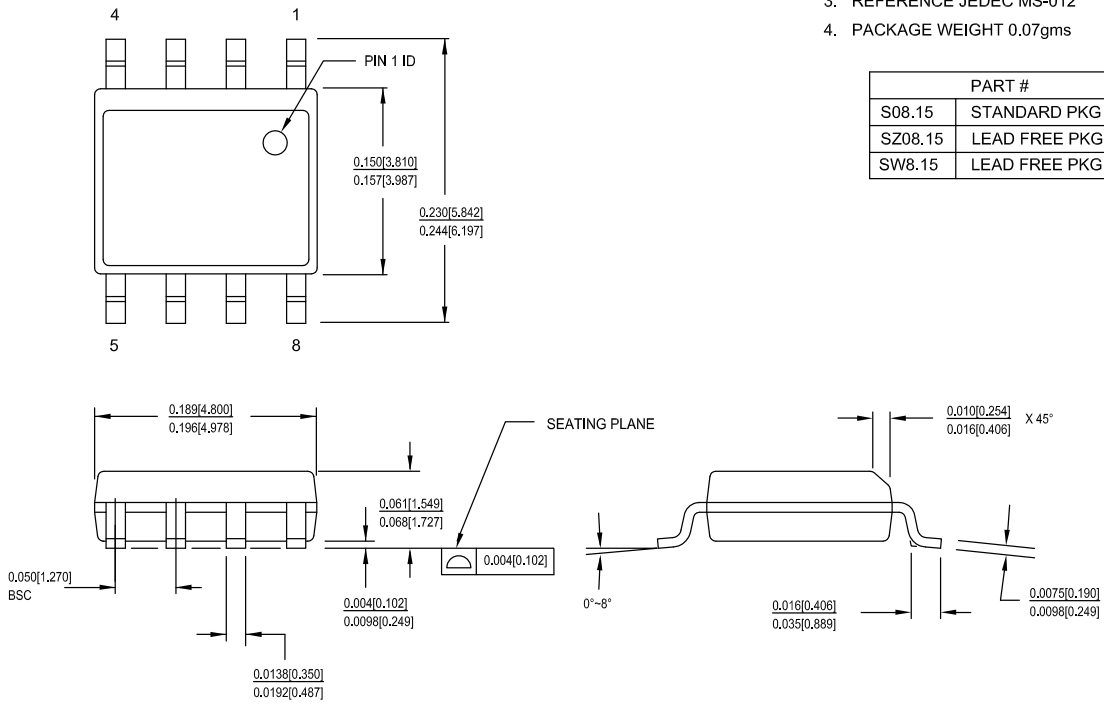

PART #	
S08.15	STANDARD PKG
SZ08.15	LEAD FREE PKG
SW8.15	LEAD FREE PKG

51-85066 *H

Acronyms

Acronym	Description
EMI	Electromagnetic Interference
ESD	Electrostatic Discharge
PLL	Phase Locked Loop
SOIC	Small Outline Integrated Circuit
SSC	Spread Spectrum Clock
SSCG	Spread Spectrum Clock Generator
SVGA	Super Video Graphics Array
XVGA	Extended Video Graphics Array

Document Conventions

Units of Measure

Symbol	Unit of Measure
°C	degree Celsius
MHz	megahertz
mA	milliampere
ns	nanosecond
%	percent
pF	picofarad
ps	picosecond
W	watt

Document History Page

Document Title: CY25560, Spread Spectrum Clock Generator Document Number: 38-07425				
Revision	ECN	Orig. of Change	Submission Date	Description of Change
**	115261	OXC	06/12/02	New data sheet.
*A	119441	RGL	10/17/02	Corrected the values in the Absolute Maximum Ratings to match the device.
*B	122704	RBI	12/30/02	Added power up requirements to maximum ratings information.
*C	125549	RGL	05/15/03	Added Industrial Temperature Range to the device. Removed V_{OL2} and V_{OH2} spec in the DC specs table Changed IDD Values from 11/17/25 typ and 14/22/34max to 17/27/42 typ and 23/41/59 max Changed T_F/T_R values from 1.3/1.3 typ and 1.6/1.6 max to 1.8/1.8 typ and 2.8/2.8 max in the Electrical Char. table. Changed $J_{CC1/2}$ values from 200/250 typ and 250/300 max to 150/130 typ to 300/200 max in the Electrical Char. table. Changed the low power dissipation from 36/56/82mW to 56/89/139mW respectively. Changed the low cycle-to-cycle jitter from 195/175/100ps-typ to 450/225/150 ps-max
*D	314293	RGL	See ECN	Updated Ordering Information : Added Pb-free devices.
*E	2762435	CXQ / HMT	09/11/09	Updated SSCG Theory of Operation : Updated SSCG : Fixed the frequency in figure. Updated Ordering Information : Removed Pb devices.
*F	2819309	VED	12/01/09	Minor change - updated revision number and corrected the document number at the beginning of this table.
*G	3343531	PURU	08/12/2011	Added Ordering Code Definitions . Added Acronyms and Units of Measure . Updated Package Drawing and Dimensions .
*H	4511394	TAVA	09/26/2014	Added XIN/CLK DC Specifications . Updated Package Drawing and Dimensions : spec 51-85066 – Changed revision from *E to *F. Updated to new template. Completing Sunset Review.
*I	4586478	TAVA	03/12/2014	Updated Functional Description : Added “For a complete list of related documentation, click here .” at the end.
*J	5270202	PSR	05/13/2016	Updated SSCG Theory of Operation : Updated SSCG : Updated Figure 3 . Added Thermal Resistance . Updated Package Drawing and Dimensions : spec 51-85066 – Changed revision from *F to *H. Updated to new template.

Sales, Solutions, and Legal Information

Worldwide Sales and Design Support

Cypress maintains a worldwide network of offices, solution centers, manufacturer's representatives, and distributors. To find the office closest to you, visit us at [Cypress Locations](#).

Products

ARM® Cortex® Microcontrollers	cypress.com/arm
Automotive	cypress.com/automotive
Clocks & Buffers	cypress.com/clocks
Interface	cypress.com/interface
Lighting & Power Control	cypress.com/powerpsoc
Memory	cypress.com/memory
PSoC	cypress.com/psoc
Touch Sensing	cypress.com/touch
USB Controllers	cypress.com/usb
Wireless/RF	cypress.com/wireless

PSoC® Solutions

[PSoC 1](#) | [PSoC 3](#) | [PSoC 4](#) | [PSoC 5LP](#)

Cypress Developer Community

[Forums](#) | [Projects](#) | [Video](#) | [Blogs](#) | [Training](#) | [Components](#)

Technical Support

cypress.com/support



© Cypress Semiconductor Corporation, 2005-2016. This document is the property of Cypress Semiconductor Corporation and its subsidiaries, including Spansion LLC ("Cypress"). This document, including any software or firmware included or referenced in this document ("Software"), is owned by Cypress under the intellectual property laws and treaties of the United States and other countries worldwide. Cypress reserves all rights under such laws and treaties and does not, except as specifically stated in this paragraph, grant any license under its patents, copyrights, trademarks, or other intellectual property rights. If the Software is not accompanied by a license agreement and you do not otherwise have a written agreement with Cypress governing the use of the Software, then Cypress hereby grants you a personal, non-exclusive, nontransferable license (without the right to sublicense) (1) under its copyright rights in the Software (a) for Software provided in source code form, to modify and reproduce the Software solely for use with Cypress hardware products, only internally within your organization, and (b) to distribute the Software in binary code form externally to end users (either directly or indirectly through resellers and distributors), solely for use on Cypress hardware product units, and (2) under those claims of Cypress's patents that are infringed by the Software (as provided by Cypress, unmodified) to make, use, distribute, and import the Software solely for use with Cypress hardware products. Any other use, reproduction, modification, translation, or compilation of the Software is prohibited.

TO THE EXTENT PERMITTED BY APPLICABLE LAW, CYPRESS MAKES NO WARRANTY OF ANY KIND, EXPRESS OR IMPLIED, WITH REGARD TO THIS DOCUMENT OR ANY SOFTWARE OR ACCOMPANYING HARDWARE, INCLUDING, BUT NOT LIMITED TO, THE IMPLIED WARRANTIES OF MERCHANTABILITY AND FITNESS FOR A PARTICULAR PURPOSE. To the extent permitted by applicable law, Cypress reserves the right to make changes to this document without further notice. Cypress does not assume any liability arising out of the application or use of any product or circuit described in this document. Any information provided in this document, including any sample design information or programming code, is provided only for reference purposes. It is the responsibility of the user of this document to properly design, program, and test the functionality and safety of any application made of this information and any resulting product. Cypress products are not designed, intended, or authorized for use as critical components in systems designed or intended for the operation of weapons, weapons systems, nuclear installations, life-support devices or systems, other medical devices or systems (including resuscitation equipment and surgical implants), pollution control or hazardous substances management, or other uses where the failure of the device or system could cause personal injury, death, or property damage ("Unintended Uses"). A critical component is any component of a device or system whose failure to perform can be reasonably expected to cause the failure of the device or system, or to affect its safety or effectiveness. Cypress is not liable, in whole or in part, and you shall and hereby do release Cypress from any claim, damage, or other liability arising from or related to all Unintended Uses of Cypress products. You shall indemnify and hold Cypress harmless from and against all claims, costs, damages, and other liabilities, including claims for personal injury or death, arising from or related to any Unintended Uses of Cypress products.

Cypress, the Cypress logo, Spansion, the Spansion logo, and combinations thereof, PSoC, CapSense, EZ-USB, F-RAM, and Traveo are trademarks or registered trademarks of Cypress in the United States and other countries. For a more complete list of Cypress trademarks, visit cypress.com. Other names and brands may be claimed as property of their respective owners.

Looking for pricing, stock, or lifecycle information?

Click below to explore more details on WIN SOURCE:

-  [View CY25560SXIT on WIN SOURCE](#)
-  [Cypress Semiconductor Corp](#) Information

Optimize Your Supply Chain with WIN SOURCE Solutions

-  Global Sourcing Solution
-  Obsolete Management
-  Cost Control Management
-  Shortage Management
-  Alternative Solution
-  Excess Inventory Management