



**THE DATASHEET OF  
ADP2323ACPZ-R7**



### FEATURES

- Input voltage: 4.5 V to 20 V**
- ±1% output accuracy**
- Integrated 90 mΩ typical high-side MOSFET**
- Flexible output configuration**
  - Dual output: 3 A/3 A
  - Parallel single output: 6 A
- Programmable switching frequency: 250 kHz to 1.2 MHz**
- External synchronization input with programmable phase shift, or internal clock output**
- Selectable PWM or PFM mode operation**
- Adjustable current limit for small inductor**
- External compensation and soft start**
- Startup into precharged output**
- Supported by ADIsimPower™ design tool**

### APPLICATIONS

- Communications infrastructure
- Networking and servers
- Industrial and instrumentation
- Healthcare and medical
- Intermediate power rail conversion
- DC-to-dc point of load applications

### GENERAL DESCRIPTION

The ADP2323 is a full featured, dual output, step-down dc-to-dc regulator based on current-mode architecture. The ADP2323 integrates two high-side power MOSFETs and two low-side drivers for the external N-channel MOSFETs. The two pulse-width modulation (PWM) channels can be configured to deliver dual 3 A outputs or a parallel-to-single 6 A output. The regulator operates from input voltages of 4.5 V to 20 V, and the output voltage can be as low as 0.6 V.

The switching frequency can be programmed between 250 kHz and 1.2 MHz, or synchronized to an external clock to minimize interference in multirail applications. The dual PWM channels run 180° out of phase, thereby reducing input current ripple as well as reducing the size of the input capacitor.

The bidirectional synchronization pin can be programmed at a 60°, 90°, or 120° phase shift, providing the possibility for a stackable multiphase power solution.

The ADP2323 can be set to operate in pulse-frequency modulation (PFM) mode at a light load for higher efficiency or in forced PWM for noise sensitive applications. External compensation and soft start provide design flexibility. Independent enable

### TYPICAL APPLICATION CIRCUIT

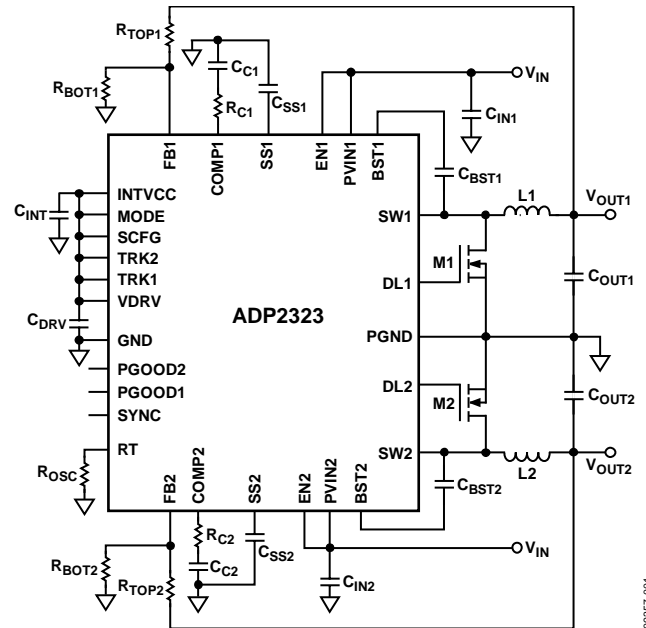

Figure 1.

inputs and power good outputs provide reliable power sequencing. To enhance system reliability, the device also includes undervoltage lockout (UVLO), overvoltage protection (OVP), overcurrent protection (OCP), and thermal shutdown (TSD).

The ADP2323 operates over the -40°C to +125°C junction temperature range and is available in a 32-lead LFCSP\_WQ package.

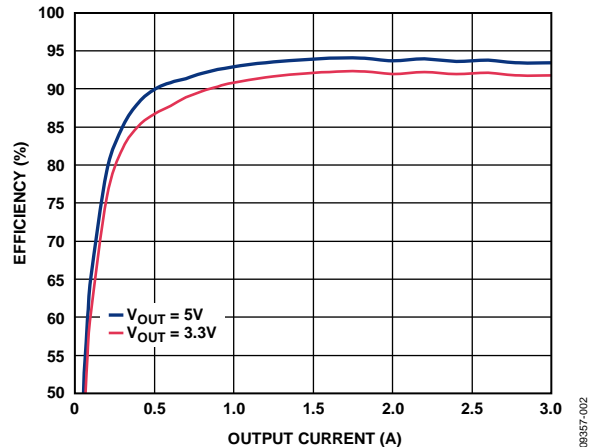

Figure 2. Efficiency vs. Output Current at  $V_{IN} = 12\text{ V}$ ,  $f_{SW} = 600\text{ kHz}$

### Rev. A

Information furnished by Analog Devices is believed to be accurate and reliable. However, no responsibility is assumed by Analog Devices for its use, nor for any infringements of patents or other rights of third parties that may result from its use. Specifications subject to change without notice. No license is granted by implication or otherwise under any patent or patent rights of Analog Devices. Trademarks and registered trademarks are the property of their respective owners.

**TABLE OF CONTENTS**

Features .....	1	Overvoltage Protection.....	17
Applications.....	1	Undervoltage Lockout .....	18
Typical Application Circuit .....	1	Thermal Shutdown .....	18
General Description .....	1	Applications Information .....	19
Revision History .....	2	ADIsimPower Design Tool .....	19
Functional Block Diagram .....	3	Input Capacitor Selection.....	19
Specifications.....	4	Output Voltage Setting .....	19
Absolute Maximum Ratings.....	6	Voltage Conversion Limitations.....	19
Thermal Resistance .....	6	Current-Limit Setting.....	19
ESD Caution.....	6	Inductor Selection .....	20
Pin Configuration and Function Descriptions.....	7	Output Capacitor Selection.....	20
Typical Performance Characteristics .....	9	Low-Side Power Device Selection.....	21
Theory of Operation .....	15	Programming UVLO Input .....	21
Control Scheme .....	15	Compensation Components Design .....	21
PWM Mode.....	15	Design Example .....	23
PFM Mode.....	15	Output Voltage Setting .....	23
Precision Enable/Shutdown .....	15	Current-Limit Setting.....	23
Separate Input Voltages .....	15	Frequency Setting.....	23
Internal Regulator (INTVCC).....	15	Inductor Selection .....	23
Bootstrap Circuitry .....	16	Output Capacitor Selection.....	23
Low-Side Driver.....	16	Low-Side MOSFET Selection .....	24
Oscillator .....	16	Compensation Components.....	24
Synchronization.....	16	Soft Start Time Programming .....	24
Soft Start .....	16	Input Capacitor Selection.....	24
Peak Current-Limit and Short-Circuit Protection.....	16	External Components Recommendation.....	25
Voltage Tracking.....	17	Typical Application Circuits .....	26
Parallel Operation.....	17	Outline Dimensions .....	31
Power Good.....	17	Ordering Guide .....	31

**REVISION HISTORY**

<b>6/12—Rev. 0 to Rev. A</b>	
Change to Features Section .....	1
Added ADIsimPower Design Tool Section.....	19

**7/11—Revision 0: Initial Version**

# FUNCTIONAL BLOCK DIAGRAM

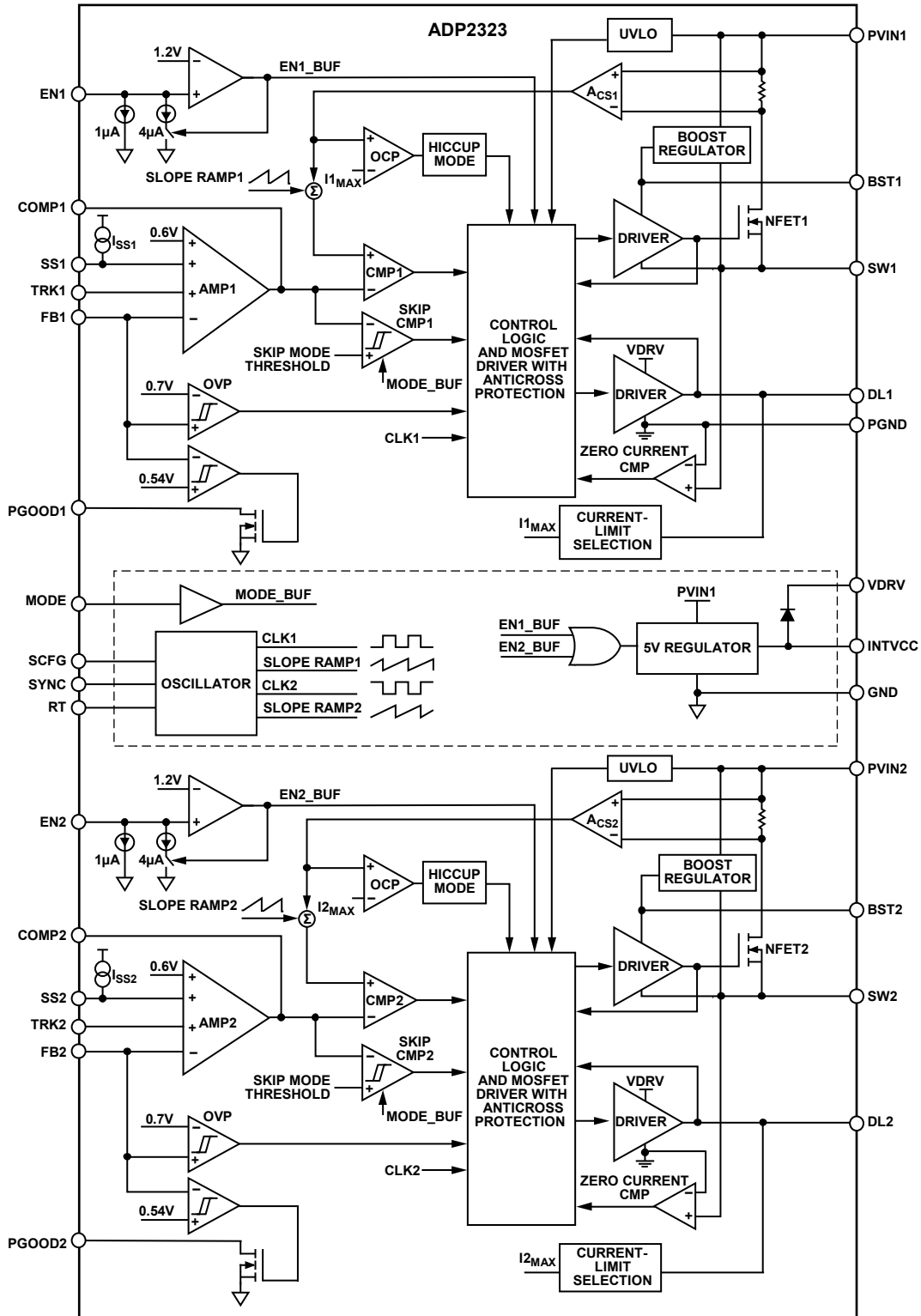

Figure 3. Functional Block Diagram

09357-042

## SPECIFICATIONS

PVIN1 = PVIN2 = 12 V at  $T_j = -40^\circ\text{C}$  to  $+125^\circ\text{C}$ , unless otherwise noted.

Table 1.

Parameters	Symbol	Test Conditions/Comments	Min	Typ	Max	Units
<b>POWER INPUT (PVINx PINS)</b>						
Power Input Voltage Range	$V_{PVIN}$		4.5		20	V
Quiescent Current (PVIN1 + PVIN2)	$I_Q$	MODE = GND, no switching		3	5	mA
Shutdown Current (PVIN1 + PVIN2)	$I_{SHDN}$	EN1 = EN2 = GND		50	100	$\mu\text{A}$
PVINx Undervoltage Lockout Threshold	UVLO			4.3	4.5	V
PVINx Rising			3.5	3.8		V
PVINx Falling						
<b>FEEDBACK (FBx PINS)</b>						
FBx Regulation Voltage <sup>1</sup>	$V_{FB}$	PVINx = 4.5 V to 20 V	0.594	0.6	0.606	V
FBx Bias Current	$I_{FB}$			0.01	0.1	$\mu\text{A}$
<b>ERROR AMPLIFIER (COMPx PINS)</b>						
Transconductance	$g_m$		230	300	370	$\mu\text{S}$
EA Source Current	$I_{SOURCE}$		25	45	65	$\mu\text{A}$
EA Sink Current	$I_{SINK}$		25	45	65	$\mu\text{A}$
<b>INTERNAL REGULATOR (INTVCC PIN)</b>						
INTVCC Voltage			4.75	5	5.25	V
Dropout Voltage		$I_{INTVCC} = 30\text{ mA}$		400		mV
Regulator Current Limit			40	75	120	mA
<b>SWITCH NODE (SWx PINS)</b>						
High-Side On Resistance <sup>2</sup>		$V_{BST}$ to $V_{SW} = 5\text{ V}$		90	130	m $\Omega$
SWx Peak Current Limit		$R_{ILIM} = \text{floating}, V_{BST}$ to $V_{SW} = 5\text{ V}$	4	4.8	5.8	A
		$R_{ILIM} = 47\text{ k}\Omega, V_{BST}$ to $V_{SW} = 5\text{ V}$	2.3	3	3.7	A
		$R_{ILIM} = 15\text{ k}\Omega, V_{BST}$ to $V_{SW} = 5\text{ V}$	0.8	1.5	2.2	A
SWx Minimum On Time <sup>3</sup>	$t_{MIN\_ON}$			130		ns
SWx Minimum Off Time <sup>3</sup>	$t_{MIN\_OFF}$			150		ns
<b>LOW-SIDE DRIVER (DLx PINS)</b>						
Rising Time <sup>3</sup>		$C_{DL} = 2.2\text{ nF}$ , see Figure 19		20		ns
Falling Time <sup>3</sup>		$C_{DL} = 2.2\text{ nF}$ , see Figure 22		10		ns
Sourcing Resistor				4	6	$\Omega$
Sinking Resistor				2	4.5	$\Omega$
<b>OSCILLATOR (RT PIN)</b>						
PWM Switching Frequency	$f_{SW}$	$R_{OSC} = 100\text{ k}\Omega$	530	600	670	kHz
PWM Frequency Range			250		1200	kHz
<b>SYNCHRONIZATION (SYNC PIN)</b>						
SYNC Input		SYNC configured as input				
Synchronization Range			300		1200	kHz
Minimum On Pulse Width			100			ns
Minimum Off Pulse Width			100			ns
High Threshold			1.3			V
Low Threshold					0.4	V
SYNC Output		SYNC configured as output				
Frequency on SYNC Pin	$f_{CLKOUT}$			$f_{SW}$		kHz
Positive Pulse Time			100			ns
<b>SOFT START (SSx PINS)</b>						
SSx Pin Source Current	$I_{SS}$		2.5	3.5	4.5	$\mu\text{A}$

Parameters	Symbol	Test Conditions/Comments	Min	Typ	Max	Units
TRACKING INPUT (TRKx PINS)						
TRKx Input Voltage Range			0		600	mV
TRKx-to-FBx Offset Voltage		TRKx = 0 mV to 500 mV	-10		+10	mV
TRKx Input Bias Current					100	nA
POWER GOOD (PGOODx PINS)						
Power Good Rising Threshold			87	90	93	%
Power Good Hysteresis				5		%
Power Good Deglitch Time		From FBx to PGOODx		16		Clock cycle
PGOODx Leakage Current		$V_{PGOOD} = 5\text{ V}$		0.1	1	$\mu\text{A}$
PGOODx Output Low Voltage		$I_{PGOOD} = 1\text{ mA}$		50	100	mV
ENABLE (ENx PINS)						
ENx Rising Threshold				1.2	1.28	V
ENx Falling Threshold			1.02	1.1		V
ENx Source Current		EN voltage below falling threshold		5		$\mu\text{A}$
		EN voltage above rising threshold		1		$\mu\text{A}$
MODE (MODE PIN)						
Input High Voltage			1.3			V
Input Low Voltage					0.4	V
THERMAL						
Thermal Shutdown Threshold				150		$^{\circ}\text{C}$
Thermal Shutdown Hysteresis				15		$^{\circ}\text{C}$

<sup>1</sup> Tested in a feedback loop that adjusts  $V_{FB}$  to achieve a specified voltage on the COMPx pin.

<sup>2</sup> Pin-to-pin measurements.

<sup>3</sup> Guaranteed by design.

## ABSOLUTE MAXIMUM RATINGS

Table 2.

Parameter	Rating
PVIN1, PVIN2, EN1, EN2	-0.3 V to +22 V
SW1, SW2	-1 V to +22 V
BST1, BST2	$V_{SW} + 6$ V
FB1, FB2, SS1, SS2, COMP1, COMP2, PGOOD1, PGOOD2, TRK1, TRK2, SCFG, SYNC, RT, MODE	-0.3 V to +6 V
INTVCC, VDRV, DL1, DL2	-0.3 V to +6 V
PGND to GND	-0.3 V to +0.3 V
Temperature Range	
Operating (Junction)	-40°C to +125°C
Storage	-65°C to +150°C
Soldering Conditions	JEDEC J-STD-020

Stresses above those listed under Absolute Maximum Ratings may cause permanent damage to the device. This is a stress rating only; functional operation of the device at these or any other conditions above those indicated in the operational section of this specification is not implied. Exposure to absolute maximum rating conditions for extended periods may affect device reliability.

## THERMAL RESISTANCE

$\theta_{JA}$  is specified for the worst-case conditions, that is, a device soldered in a circuit board for surface-mount packages.

### Boundary Condition

$\theta_{JA}$  is measured using natural convection on a JEDEC 4-layer board, and the exposed pad is soldered to the printed circuit board (PCB) with thermal vias.

Table 3. Thermal Resistance

Package Type	$\theta_{JA}$	Unit
32-Lead LFCSP_WQ	32.7	°C/W

## ESD CAUTION



### ESD (electrostatic discharge) sensitive device.

Charged devices and circuit boards can discharge without detection. Although this product features patented or proprietary protection circuitry, damage may occur on devices subjected to high energy ESD. Therefore, proper ESD precautions should be taken to avoid performance degradation or loss of functionality.

## PIN CONFIGURATION AND FUNCTION DESCRIPTIONS

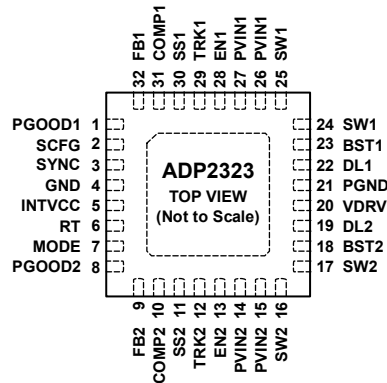

## NOTES

1. THE EXPOSED PAD SHOULD BE SOLDERED TO AN EXTERNAL GND PLANE.

09357-003

Figure 4. Pin Configuration (Top View)

Table 4. Pin Function Descriptions

Pin No.	Mnemonic	Description
1	PGOOD1	Power-Good Output (Open Drain) for Channel 1. A pull-up resistor of 10 kΩ to 100 kΩ is recommended.
2	SCFG	Synchronization Configuration Input. The SCFG pin configures the SYNC pin as an input or output. Connect SCFG to INTVCC to configure SYNC as an output. Using a resistor to pull down to GND configures SYNC as an input with various phase shift degrees.
3	SYNC	Synchronization. This pin can be configured as an input or an output. When configured as an output, it provides a clock at the switching frequency. When configured as an input, this pin accepts an external clock to which the regulators are synchronized and the phase shift is configured by SCFG. Note that when SYNC is configured as an input, the PFM mode is disabled and the device works only in continuous conduction mode (CCM).
4	GND	Analog Ground. Connect to the ground plane.
5	INTVCC	Internal 5 V Regulator Output. The IC control circuits are powered from this voltage. Place a 1 μF ceramic capacitor between INTVCC and GND.
6	RT	Connect a resistor between RT and GND to program the switching frequency between 250 kHz and 1.2 MHz.
7	MODE	Mode Selection. When this pin is connected to INTVCC, the PFM mode is disabled and the regulator works only in CCM. When this pin is connected to ground, the PFM mode is enabled. If the low-side device is a diode, the MODE pin must be connected to ground.
8	PGOOD2	Power-Good Output (Open Drain) for Channel 2. A pull-up resistor of 10 kΩ to 100 kΩ is recommended.
9	FB2	Feedback Voltage Sense Input for Channel 2. Connect to a resistor divider from the Channel 2 output voltage, $V_{OUT2}$ . Connect FB2 to INTVCC for parallel applications.
10	COMP2	Error Amplifier Output for Channel 2. Connect an RC network from COMP2 to GND. Connect COMP1 and COMP2 together for parallel applications.
11	SS2	Soft Start Control for Channel 2. Connect a capacitor from SS2 to GND to program the soft start time. For parallel applications, SS2 remains open.
12	TRK2	Tracking Input for Channel 2. To track a master voltage, drive this pin from a voltage divider from the master voltage. If the tracking function is not used, connect TRK2 to INTVCC.
13	EN2	Enable Pin for Channel 2. An external resistor divider can be used to set the turn-on threshold. When not using the enable pin, connect EN2 to PVIN2.
14, 15	PVIN2	Power Input for Channel 2. Connect PVIN2 to the input power source, and connect a bypass capacitor between PVIN2 and ground.
16, 17	SW2	Switch Node for Channel 2.
18	BST2	Supply Rail for the Gate Drive of Channel 2. Place a 0.1 μF capacitor between SW2 and BST2.
19	DL2	Low-Side Gate Driver Output for Channel 2. Connect a resistor between DL2 and PGND to program the current-limit threshold of Channel 2.
20	VDRV	Low-Side Driver Supply Input. Connect VDRV to INTVCC. Place a 1 μF ceramic capacitor between the VDRV pin and PGND.
21	PGND	Driver Power Ground. Connect to the source of the synchronous N-channel MOSFET.
22	DL1	Low-Side Gate Driver Output for Channel 1. Connect a resistor between this pin and PGND to program the current-limit threshold of Channel 1.

Pin No.	Mnemonic	Description
23	BST1	Supply Rail for the Gate Drive of Channel 1. Place a 0.1 $\mu$ F capacitor between SW1 and BST1.
24, 25	SW1	Switch Node for Channel 1.
26, 27	PVIN1	Power Input for Channel 1. This pin is the power input for Channel 1 and provides power for the internal regulator. Connect to the input power source and connect a bypass capacitor between PVIN1 and ground.
28	EN1	Enable Pin for Channel 1. An external resistor divider can be used to set the turn-on threshold. When not using the enable pin, connect the EN1 pin to PVIN1.
29	TRK1	Tracking Input for Channel 1. To track a master voltage, drive this pin from a voltage divider from the master voltage. If the tracking function is not used, connect TRK1 to INTVCC.
30	SS1	Soft Start Control for Channel 1. To program the soft start time, connect a capacitor from SS1 to GND.
31	COMP1	Error Amplifier Output for Channel 1. Connect an RC network from COMP1 to GND. Connect COMP1 and COMP2 together for a parallel application.
32	FB1	Feedback Voltage Sense Input for Channel 1. Connect to a resistor divider from the Channel 1 output voltage, $V_{OUT1}$ .
	Exposed Pad	Solder the exposed pad to an external GND plane.

# TYPICAL PERFORMANCE CHARACTERISTICS

Operating conditions:  $T_A = 25^\circ\text{C}$ ,  $V_{IN} = 12\text{ V}$ ,  $V_{OUT} = 3.3\text{ V}$ ,  $L = 4.7\ \mu\text{H}$ ,  $C_{OUT} = 2 \times 47\ \mu\text{F}$ ,  $f_{SW} = 600\text{ kHz}$ , unless otherwise noted.

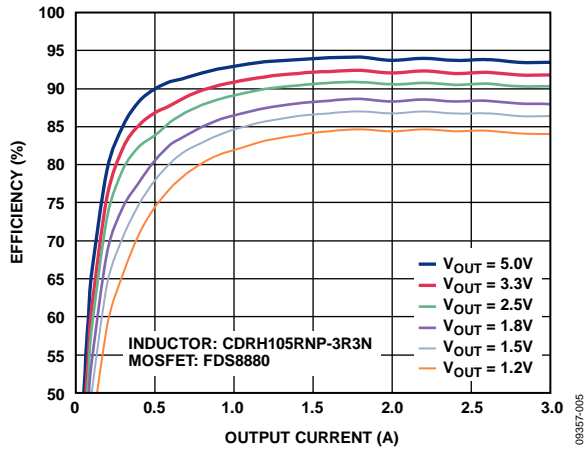

Figure 5. Efficiency at  $V_{IN} = 12\text{ V}$ ,  $f_{SW} = 600\text{ kHz}$ , FPWM

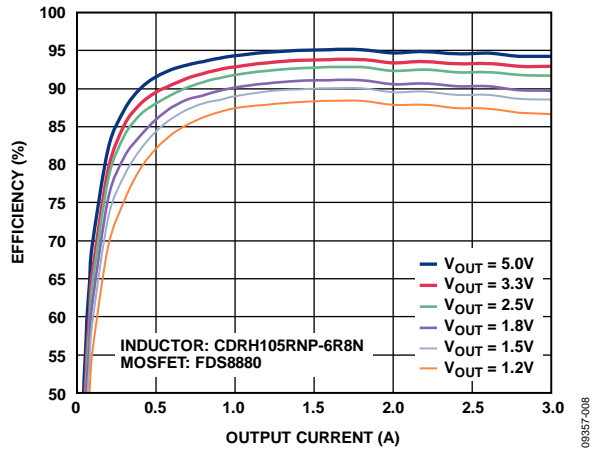

Figure 8. Efficiency at  $V_{IN} = 12\text{ V}$ ,  $f_{SW} = 300\text{ kHz}$ , FPWM

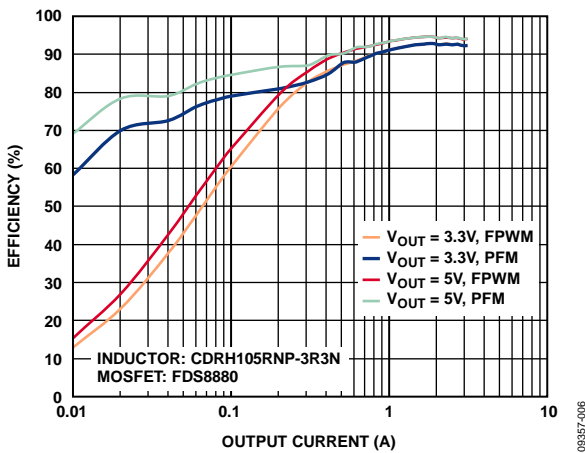

Figure 6. Efficiency at  $V_{IN} = 12\text{ V}$ ,  $f_{SW} = 600\text{ kHz}$ , PFM

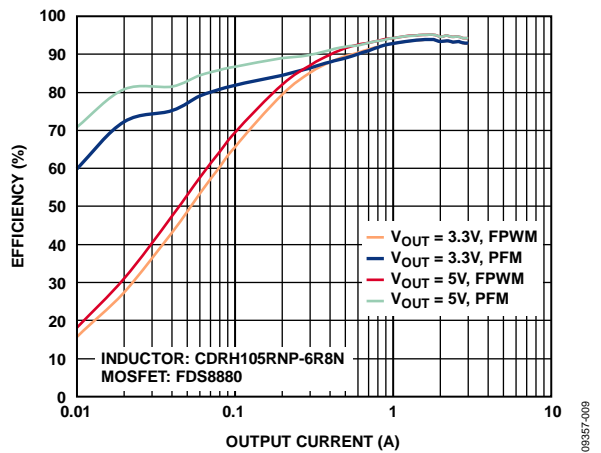

Figure 9. Efficiency at  $V_{IN} = 12\text{ V}$ ,  $f_{SW} = 300\text{ kHz}$ , PFM

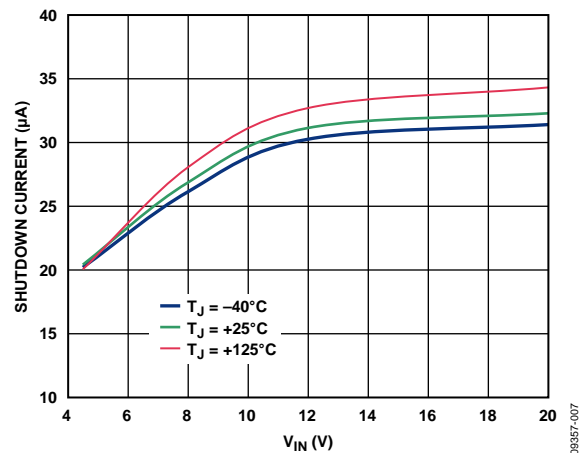

Figure 7. Shutdown Current vs.  $V_{IN}$

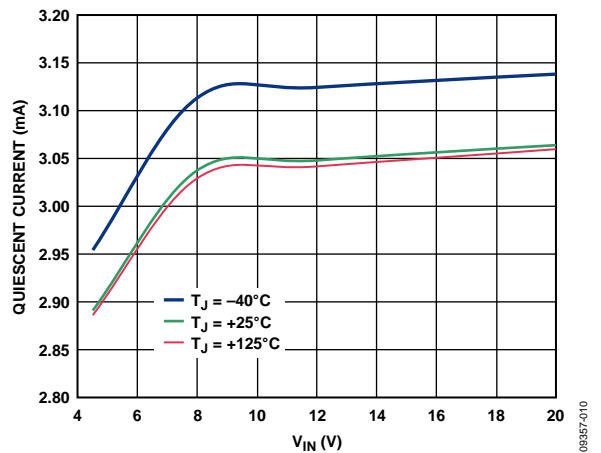

Figure 10. Quiescent Current vs.  $V_{IN}$

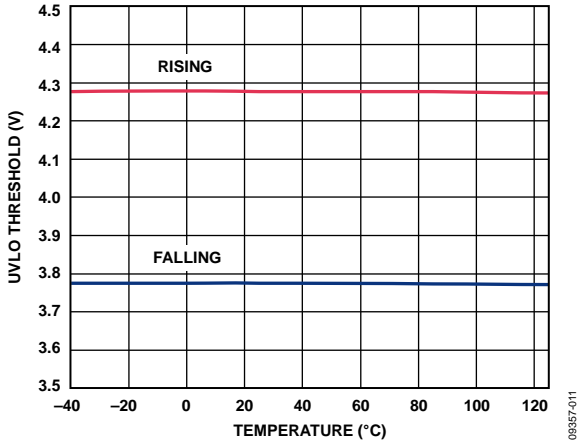

Figure 11. UVLO Threshold vs. Temperature

09357-011

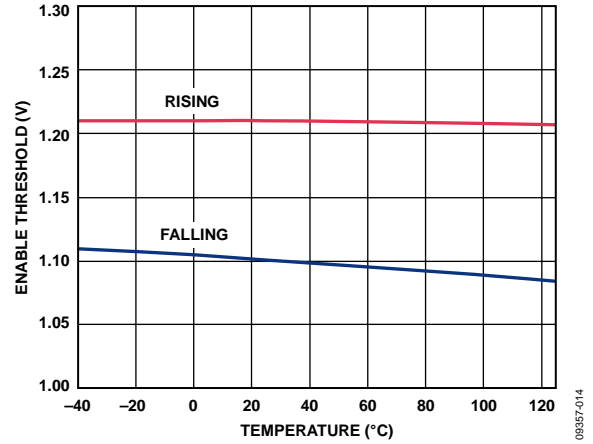

Figure 14. EN Threshold vs. Temperature

09357-014

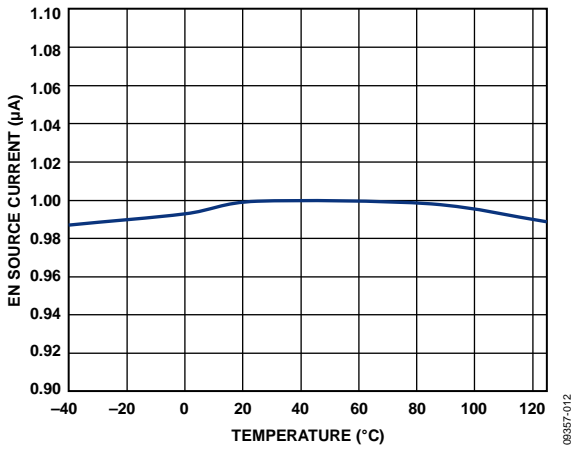

Figure 12. EN Source Current at  $V_{EN} = 1.5 V$

09357-012

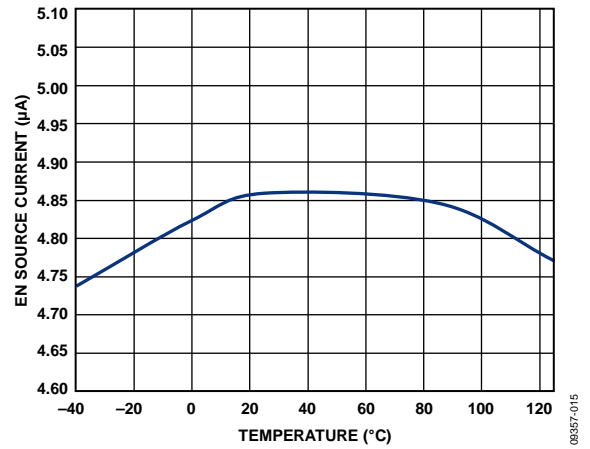

Figure 15. EN Source Current at  $V_{EN} = 1 V$

09357-015

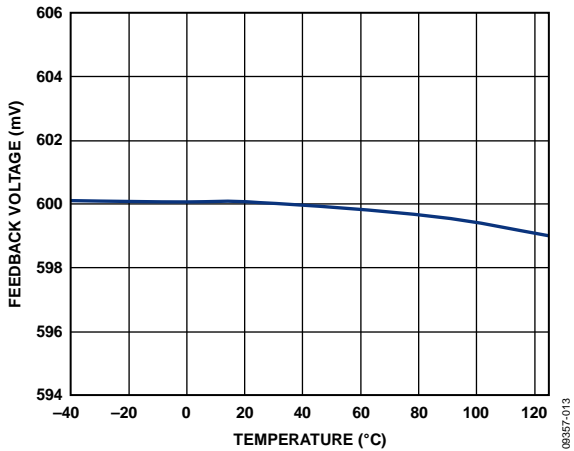

Figure 13. FB Voltage vs. Temperature

09357-013

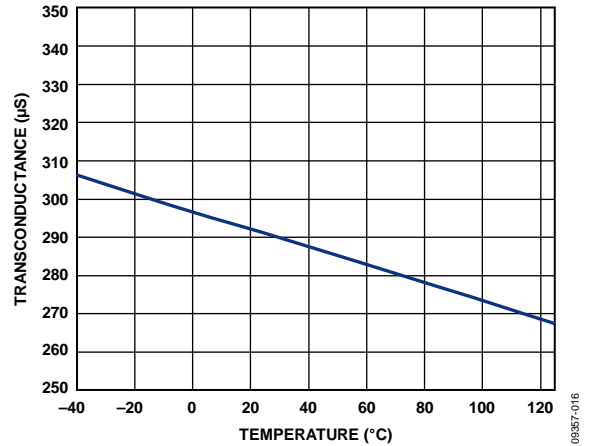

Figure 16.  $g_m$  vs. Temperature

09357-016

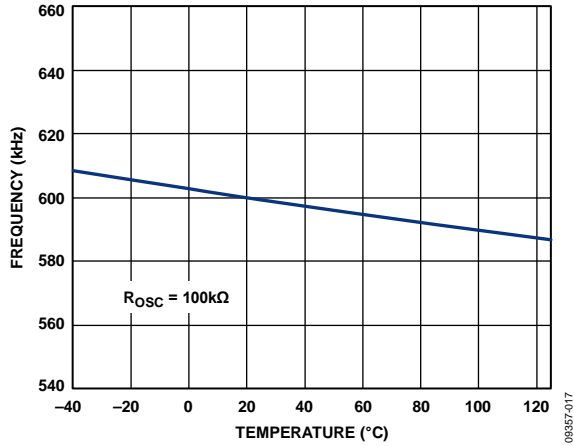

Figure 17. Frequency vs. Temperature

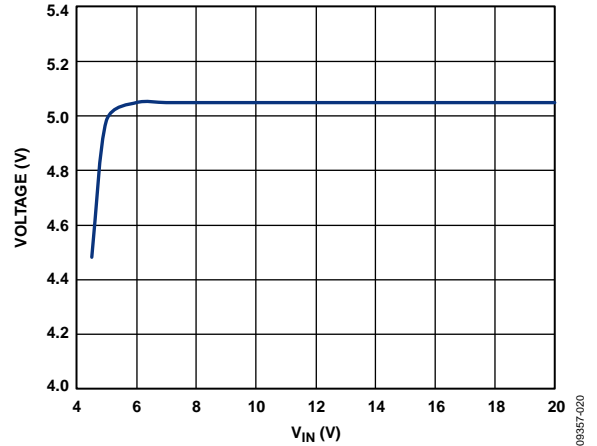

Figure 20. INTVCC Voltage vs. V<sub>IN</sub>

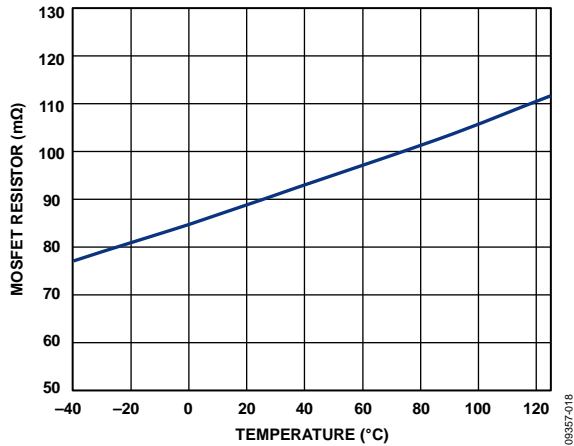

Figure 18. MOSFET R<sub>DS(on)</sub> vs. Temperature

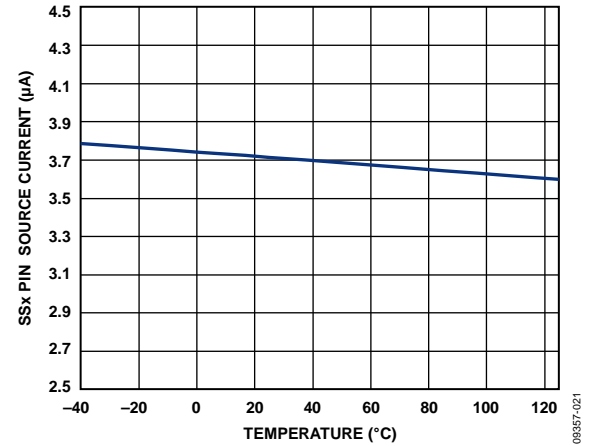

Figure 21. SSx Pin Source Current vs. Temperature

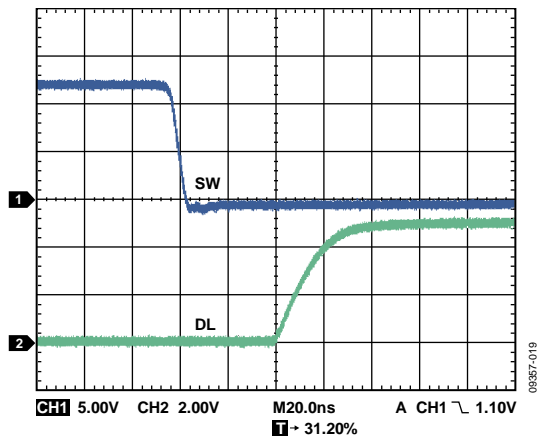

Figure 19. Low-Side Driver Rising Edge Waveform, C<sub>DL</sub> = 2.2 nF

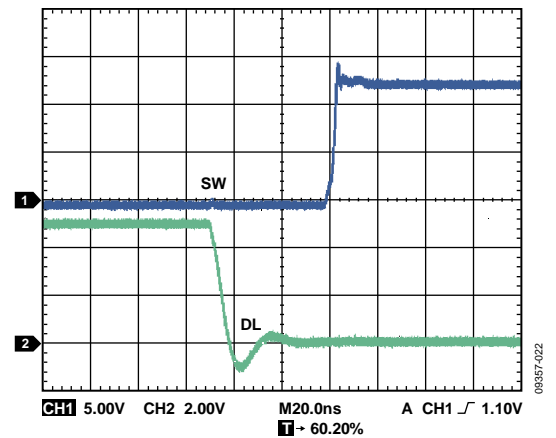

Figure 22. Low-Side Driver Falling Edge Waveform, C<sub>DL</sub> = 2.2 nF

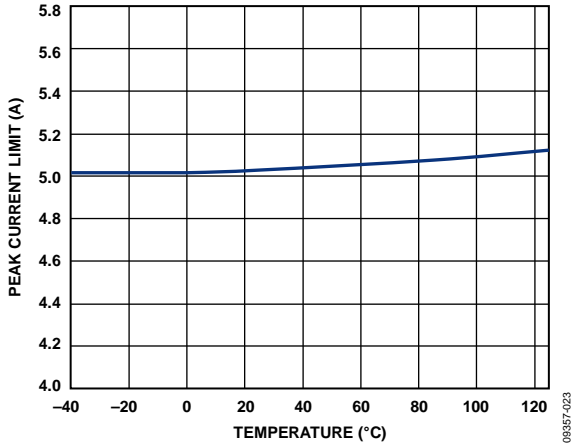

Figure 23. Current-Limit Threshold vs. Temperature,  $R_{ILIM} = \text{Floating}$

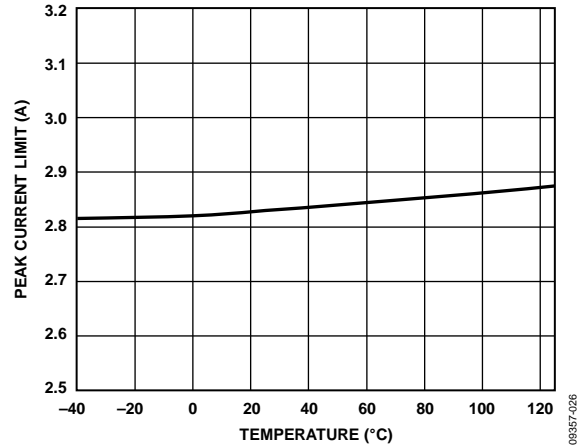

Figure 26. Current-Limit Threshold vs. Temperature,  $R_{ILIM} = 47 \text{ k}\Omega$

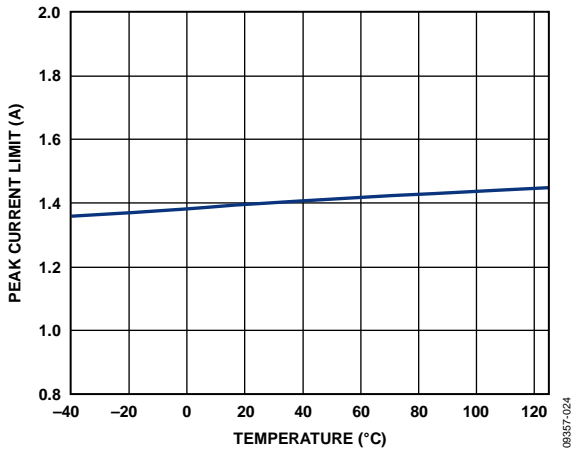

Figure 24. Current-Limit Threshold vs. Temperature,  $R_{ILIM} = 15 \text{ k}\Omega$

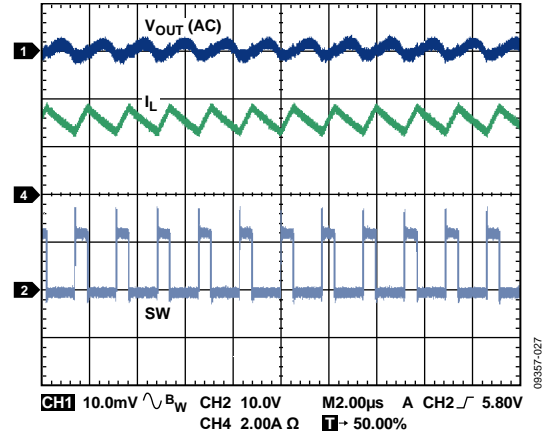

Figure 27. Continuous Conduction Mode (CCM)

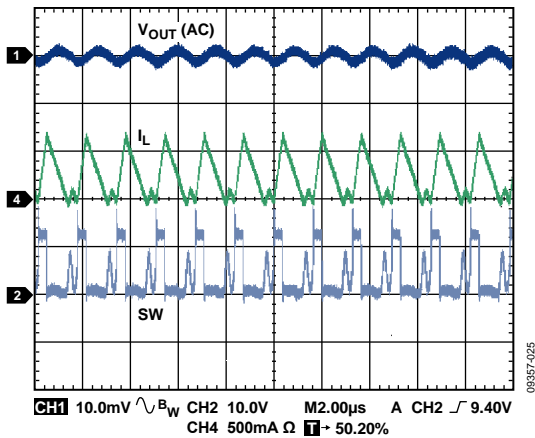

Figure 25. Discontinuous Conduction Mode (DCM)

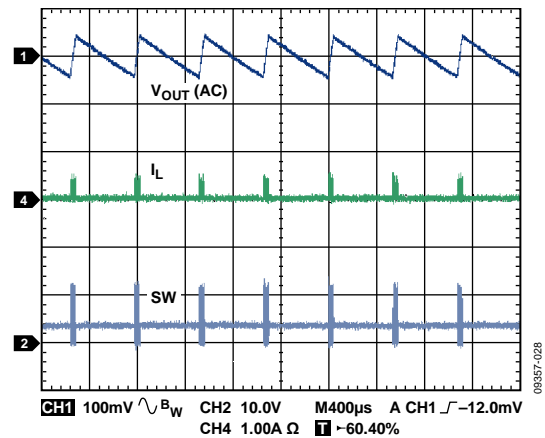

Figure 28. Power Saving Mode

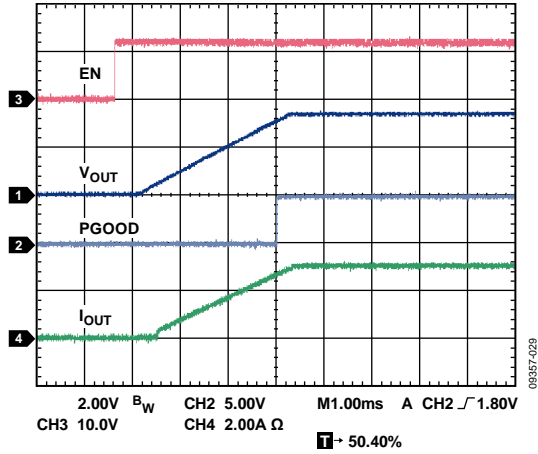

Figure 29. Soft Start With Full Load

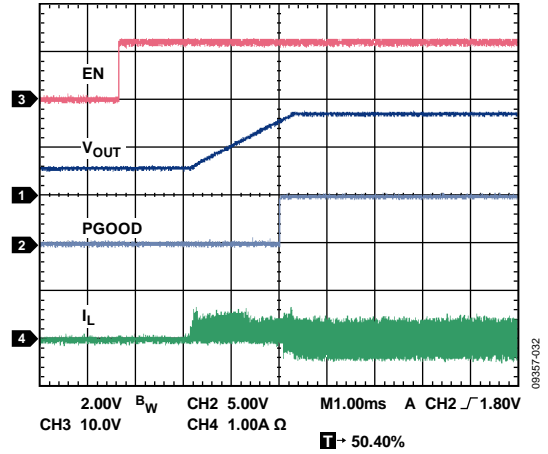

Figure 32. Precharged Output

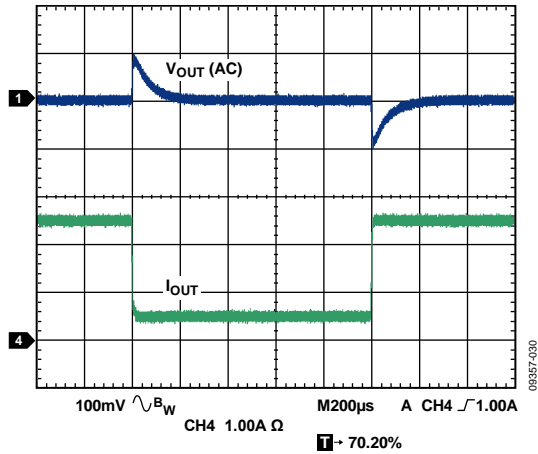

Figure 30. Load Transient Response, 0.5 A to 2.5 A

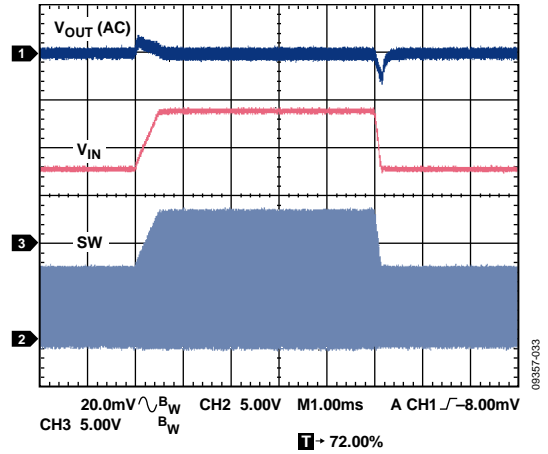

Figure 33. Line Transient Response,  $V_{IN}$  from 8 V to 14 V,  $I_{OUT} = 3$  A

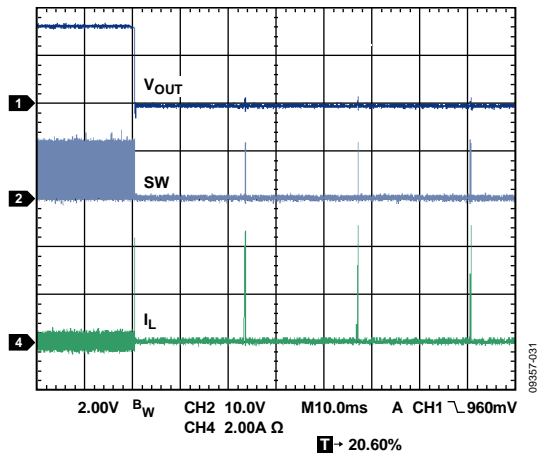

Figure 31. Output Short

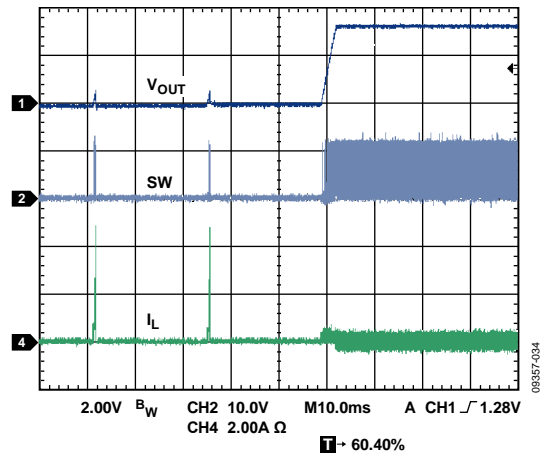

Figure 34. Output Short Recovery

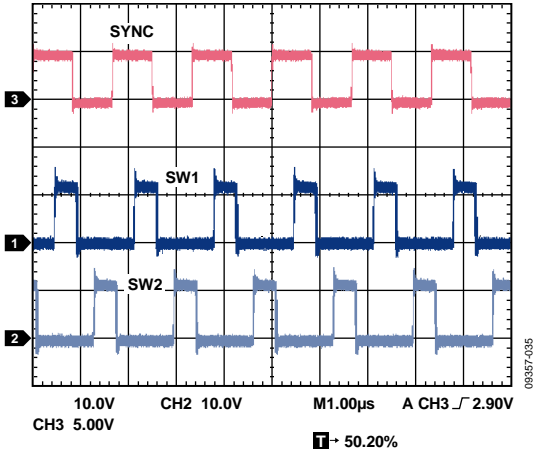

Figure 35. External Synchronization with 60° Phase Shift

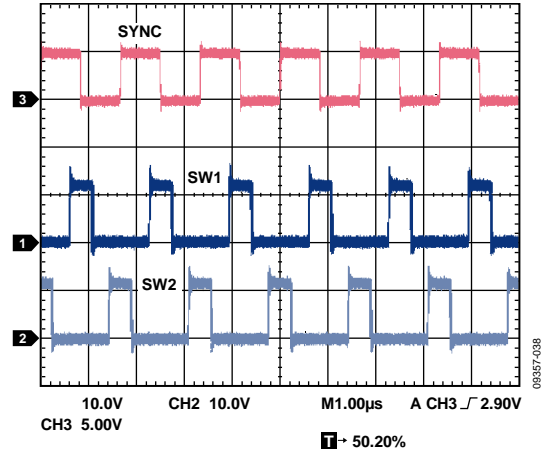

Figure 38. External Synchronization with 90° Phase Shift

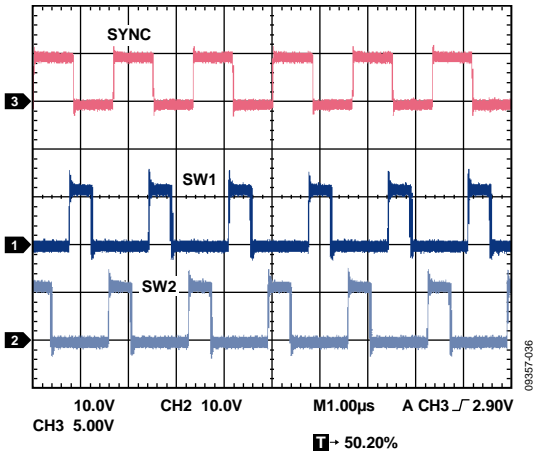

Figure 36. External Synchronization with 120° Phase Shift

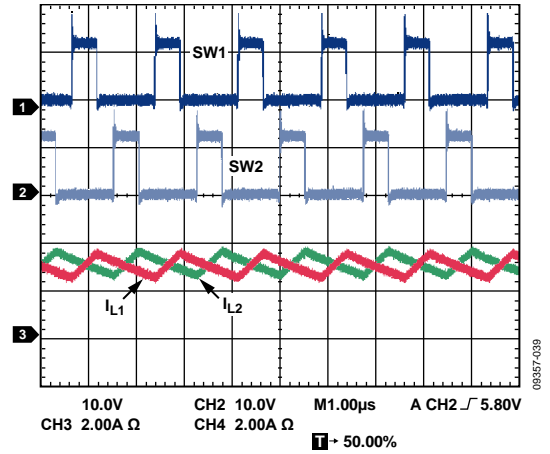

Figure 39. Dual Phase, Single Output,  $V_{OUT} = 3.3V$ ,  $I_{OUT} = 6A$

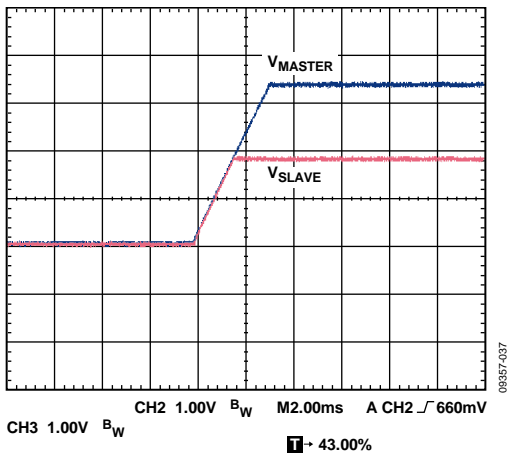

Figure 37. Coincident Tracking

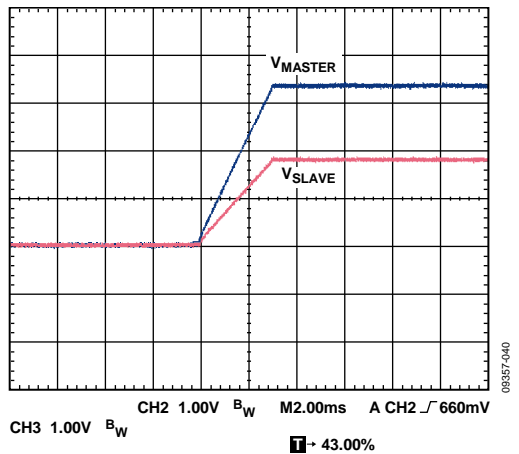

Figure 40. Ratiometric Tracking

## THEORY OF OPERATION

The **ADP2323** is a full featured, dual output, step-down dc-to-dc regulator based on current-mode architecture. It integrates two high-side power MOSFETs and two low-side drivers for external MOSFETs. The **ADP2323** targets high performance applications that require high efficiency and design flexibility.

The **ADP2323** can operate with an input voltage from 4.5 V to 20 V, and can regulate the output voltage down to 0.6 V. Additional features for flexible design include programmable switching frequency, programmable soft start, external compensation, independent enable inputs, and power good outputs.

### CONTROL SCHEME

The **ADP2323** uses a fixed frequency, current-mode PWM control architecture during medium to full loads, but shifts to a power save mode (PFM) at light loads when the PFM mode is enabled. The power save mode reduces switching losses and boosts efficiency under light loads. When operating in the fixed frequency PWM mode, the duty cycle of the integrated N-channel MOSFET (referred to interchangeably as NFET or MOSFET) is adjusted, which, in turn, regulates the output voltage. When operating in power save mode, the switching frequency is adjusted to regulate the output voltage.

### PWM MODE

In PWM mode, the **ADP2323** operates at a fixed frequency that is set by an external resistor. At the start of each oscillator cycle, the high-side NFET turns on, placing a positive voltage across the inductor. The inductor current increases until the current sense signal crosses the peak inductor current threshold that turns off the high-side NFET and turns on the low-side NFET (diode). This places a negative voltage across the inductor causing the inductor current to reduce. The low-side NFET (diode) stays on for the remainder of the cycle or until the inductor current reaches zero.

### PFM MODE

Pull the MODE pin to ground to enable the PFM mode. When the COMPx voltage is below the PFM threshold voltage, the device enters the PFM mode.

When the device enters the PFM mode, it monitors the FBx voltage to regulate the output voltage. Because the high-side and low-side NFETs are turned off, the output voltage drops due to the load current discharging the output capacitor. When the FBx voltage drops below 0.605 V, the device starts switching and the output voltage increases as the output capacitor is charged by the inductor current. When the FBx voltage exceeds 0.62 V, the device turns off both the high-side and low-side NFETs until the FBx voltage drops to 0.605 V. In the PFM mode, the output voltage ripple is larger than the ripple in the PWM mode.

### PRECISION ENABLE/SHUTDOWN

The **ADP2323** has two independent enable pins (EN1 and EN2) for each channel. The ENx pin has an internal pull-down current source (5  $\mu$ A) that provides default turn off when an ENx pin is open.

When the voltage on the EN1 or EN2 pin exceeds 1.2 V (typical), Channel 1 or Channel 2 is enabled and the internal pull-down current source at the EN1 or EN2 pin is reduced to 1  $\mu$ A, which allows the user to program the input voltage undervoltage lockout (UVLO).

When the voltage on the EN1 or EN2 pin drops below 1.1 V (typical), Channel 1 or Channel 2 turns off. When EN1 and EN2 are both below 1.1 V, all of the internal circuits turn off and the device enters the shutdown mode.

### SEPARATE INPUT VOLTAGES

The **ADP2323** supports two separate input voltages. This means that the PVIN1 and PVIN2 voltages can be connected to two different supply voltages. In these types of applications, the PVIN1 voltage needs to be above the UVLO voltage before the PVIN2 voltage begins to rise because the PVIN1 voltage provides the power supply for the internal regulator and control circuitry.

This feature makes it possible for a cascading supply operation as shown in Figure 41, where PVIN2 is sourced from the Channel 1 output. In this configuration, the Channel 1 output voltage needs to be high enough to maintain Channel 2 in regulation, and the Channel 1 output voltage needs to be higher than the input voltage UVLO threshold.

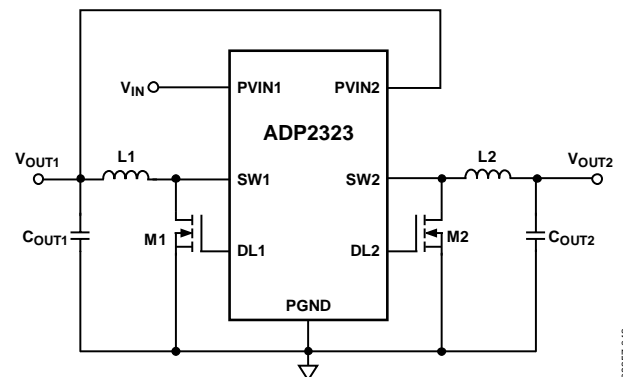

Figure 41. Cascading Supply Operation

### INTERNAL REGULATOR (INTVCC)

The internal regulator provides a stable voltage supply for the internal control circuits and bias voltage for the low-side gate drivers. A 1  $\mu$ F ceramic capacitor is recommended to be placed between INTVCC and GND. The internal regulator also includes a current-limit circuit for protection.

The internal regulator is active when either one of the channels is enabled. The PVIN1 pin provides power for the internal regulator that is used by both channels.

**BOOTSTRAP CIRCUITRY**

The ADP2323 integrates the boot regulators to provide the gate drive voltage for the high-side NFETs. The regulators generate 5 V bootstrap voltages between the BSTx pin and the SWx pin.

It is recommended that an X7R or an X5R, 0.1 μF ceramic capacitor be placed between the BSTx and the SWx pins.

**LOW-SIDE DRIVER**

The DLx pin provides the gate drive for the low-side N-channel MOSFET. Internal circuitry monitors the gate driver signal to ensure break-before-make switching to prevent cross conduction.

The VDRV pin provides the power supply to the low-side drivers. It is limited to a 5.5 V maximum input, and placing a 1 μF ceramic capacitor close to this pin is recommended.

**OSCILLATOR**

A resistor from RT to GND programs the switching frequency according to the following equation:

$$f_{sw} \text{ [kHz]} = \frac{60,000}{R_{osc} \text{ [k}\Omega\text{]}}$$

A 200 kΩ resistor sets the frequency to 300 kHz, and a 100 kΩ resistor sets the frequency to 600 kHz. Figure 42 shows the typical relationship between  $f_{sw}$  and  $R_{osc}$ .

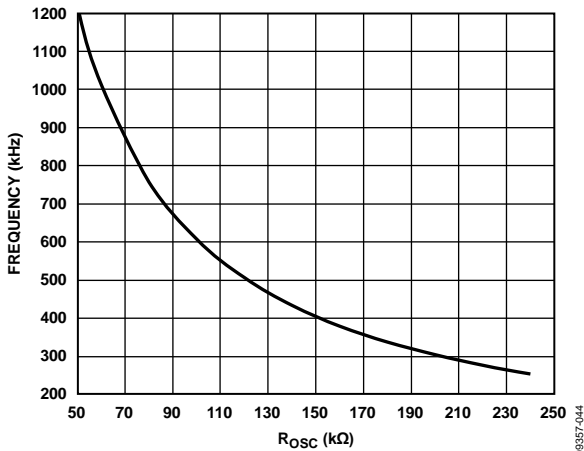

Figure 42.  $f_{sw}$  vs.  $R_{osc}$

**SYNCHRONIZATION**

The SYNC pin can be configured as an input or an output by setting the SCFG pin as shown in Table 5.

Table 5. SCFG Configuration

SCFG	SYNC	Phase Shift
High	Output	0°
GND	Input	90°
180 kΩ to GND	Input	120°
100 kΩ to GND	Input	60°

When the SYNC pin is configured as an output, it generates a clock with a frequency that is equal to the internal switching frequency.

When the SYNC pin is configured as an input, the ADP2323 synchronizes to the external clock that is applied to the SYNC pin, and the internal clock must be programmed lower than the external clock. The phase shift can be programmed by the SCFG pin.

When working in synchronization mode, the ADP2323 disables the PFM mode and works only in the CCM mode.

**SOFT START**

The SSx pins are used to program the soft start time. Place a capacitor between SSx and GND; an internal current charges this capacitor to establish the soft start ramp. The soft start time can be calculated using the following equation:

$$T_{ss} = \frac{0.6 V \times C_{ss}}{I_{ss}}$$

where:

$C_{ss}$  is the soft start capacitance.

$I_{ss}$  is the soft start pull-up current (3.5 μA).

If the output voltage is precharged prior to power up, the ADP2323 prevents the low-side MOSFET from turning on until the soft start voltage exceeds the voltage on the FBx pin.

During soft start, the ADP2323 uses frequency foldback to prevent output current runaway. The switching frequency is reduced according to the voltage present at the FBx pin, which allows more time for the inductor to discharge. The correlation between the switching frequency and the FBx pin voltage is listed in Table 6.

Table 6. FBx Pin Voltage and Switching Frequency

FBx Pin Voltage	Switching Frequency
$V_{FB} \geq 0.4 V$	$f_{sw}$
$0.4 V > V_{FB} \geq 0.2 V$	$1/2 f_{sw}$
$V_{FB} < 0.2 V$	$1/4 f_{sw}$

**PEAK CURRENT-LIMIT AND SHORT-CIRCUIT PROTECTION**

The ADP2323 uses a peak current-limit protection circuit to prevent current runaway. Place a resistor between DLx and PGND to program the current-limit value listed in Table 7. The programmable current-limit threshold feature allows for the use of a small size inductor for low current applications.

Table 7. Peak Current-Limit Threshold Setting

R <sub>ILIM</sub>	Peak Current-Limit Threshold
Floating	4.8 A
47 kΩ	3 A
15 kΩ	1.5 A

The ADP2323 uses hiccup mode for overcurrent protection. When the peak inductor current reaches the current-limit threshold, the high-side MOSFET turns off and the low-side driver turns on until the next cycle while the overcurrent counter increments.

If the overcurrent counter reaches 10, or the FBx pin voltage falls to 0.51 V after the soft start, the device enters hiccup mode. During this mode, the high-side MOSFET and low-side driver are both turned off. The device remains in this mode for seven soft start times and then attempts to restart from soft start. If the current-limit fault is cleared, the device resumes normal operation; otherwise, it reenters hiccup mode.

In some cases, the input voltage (PVIN) ramp rate is too slow or the output capacitor is too large to support the setting regulation voltage during the soft start causing the device to enter the hiccup mode. To avoid such cases, use a resistor divider at the ENx pin to program the input voltage UVLO or use a longer soft start time.

**VOLTAGE TRACKING**

The ADP2323 has a tracking input, TRKx, that allows the output voltage to track an external (master) voltage. It allows power sequencing applicable to FPGAs, DSPs, and ASICs, which may require a power sequence between the core and the I/O voltages.

The internal error amplifier includes three positive inputs: the internal reference voltage, the soft start voltage, and the tracking input voltage. The error amplifier regulates the feedback voltage to the lowest of the three voltages. To track a master voltage, tie the TRKx pin to a resistor divider from the master voltage as shown in Figure 43.

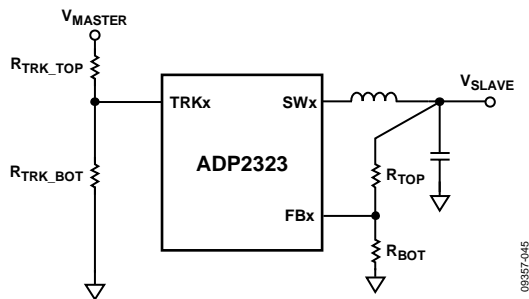

Figure 43. Voltage Tracking

A common application is coincident tracking, which is shown in Figure 44. Coincident tracking limits the slave output voltage to be the same as the master voltage until it reaches regulation. For coincident tracking, set  $R_{TRK\_TOP} = R_{TOP}$  and  $R_{TRK\_BOT} = R_{BOT}$ .

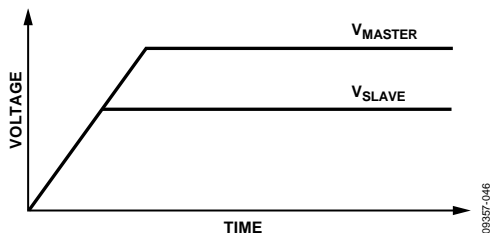

Figure 44. Coincident Tracking

Ratiometric tracking is shown in Figure 45. The slave output is limited to a fraction of the master voltage. In this application, the slave and master voltages reach the final value at the same time.

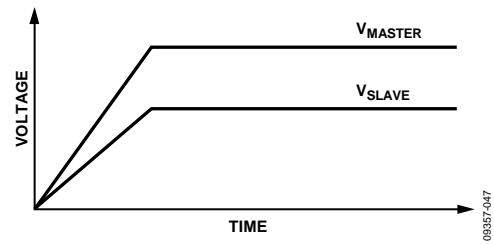

Figure 45. Ratiometric Tracking

The ratio of the slave output voltage to the master voltage is a function of the two dividers, as follows:

$$\frac{V_{SLAVE}}{V_{MASTER}} = \frac{1 + \frac{R_{TOP}}{R_{BOT}}}{1 + \frac{R_{TRK\_TOP}}{R_{TRK\_BOT}}}$$

The final TRKx pin voltage must be higher than 0.54 V. If the TRK function is not used, connect the TRKx pin to INTVCC.

**PARALLEL OPERATION**

ADP2323 supports a two phase parallel operation to provide a single output of 6 A. To configure the ADP2323 as a two phase single output

1. Connect the FB2 pin to INTVCC, thereby disabling the Channel 2 error amplifier.
2. Connect COMP1 to COMP2 and connect EN1 to EN2.
3. Use SS1 to set the soft start time and keep SS2 open.

During parallel operation, the voltages of PVIN1 and PVIN2 should be the same.

**POWER GOOD**

The power good (PGOODx) pin is an active high, open drain output that indicates if the regulator output voltage is within regulation. High indicates that the voltage at an FBx pin (and, hence, the output voltage) is above 90% of the reference voltage. Low indicates that the voltage at an FBx pin (and, hence, the output voltage) is below 85% of the reference voltage. There is a 16-cycle deglitch time between FBx and PGOODx.

**OVERVOLTAGE PROTECTION**

The ADP2323 provides an overvoltage protection (OVP) feature to protect the system against the output shorting to a higher voltage supply or when a strong load transient occurs. If the feedback voltage increases to 0.7 V, the internal high-side MOSFET and low-side driver turn off until the voltage at the FBx pin reduces to 0.63 V, at which time the ADP2323 resumes normal operation.

**UNDERVOLTAGE LOCKOUT**

The undervoltage lockout (UVLO) threshold is 4.2 V with 0.5 V hysteresis to prevent the device from power-on glitches. When the PVIN1 or PVIN2 voltage rises above 4.2 V, Channel 1 or Channel 2 is enabled and the soft start period initiates. When either PVIN1 or PVIN2 drops below 3.7 V, it turns off Channel 1 or Channel 2, respectively.

**THERMAL SHUTDOWN**

In the event that the [ADP2323](#) junction temperature exceeds 150°C, the thermal shutdown circuit turns off the regulator. A 15°C hysteresis is included so that the [ADP2323](#) does not recover from thermal shutdown until the on-chip temperature drops below 135°C. Upon recovery, soft start is initiated prior to normal operation.

## APPLICATIONS INFORMATION

### ADIsimPower DESIGN TOOL

The ADP2323 is supported by the [ADIsimPower](#) design tool set. [ADIsimPower](#) is a collection of tools that produce complete power designs optimized for a specific design goal. The tools enable the user to generate a full schematic and bill of materials, and calculate performance in minutes. [ADIsimPower](#) can optimize designs for cost, area, efficiency, and parts count while taking into consideration the operating conditions and limitations of the IC and all real external components. For more information about [ADIsimPower](#) design tools, refer to [www.analog.com/ADIsimPower](http://www.analog.com/ADIsimPower). The tool set is available from this website, and users can request an unpopulated board through the tool.

### INPUT CAPACITOR SELECTION

The input decoupling capacitor attenuates high frequency noise on the input and acts as an energy reservoir. This capacitor should be a ceramic capacitor in the range of 10  $\mu\text{F}$  to 47  $\mu\text{F}$  and must be placed close to the PVINx pin. The loop composed of this input capacitor, high-side NFET, and low-side NFET must be kept as small as possible. The voltage rating of the input capacitor must be greater than the maximum input voltage. The rms current rating of the input capacitor should be larger than the following equation:

$$I_{C_{IN\_rms}} = I_{OUT} \times \sqrt{D \times (1-D)}$$

### OUTPUT VOLTAGE SETTING

The output voltage of the [ADP2323](#) can be set by an external resistive divider using the following equation:

$$V_{OUT} = 0.6 \times \left( 1 + \frac{R_{TOP}}{R_{BOT}} \right)$$

To limit output voltage accuracy degradation due to FBx pin bias current (0.1  $\mu\text{A}$  maximum) to less than 0.5% (maximum), ensure that  $R_{BOT}$  is less than 30  $\text{k}\Omega$ .

Table 8 provides the recommended resistive divider for various output voltage options.

**Table 8. Resistive Divider for Various Output Voltages**

$V_{OUT}$ (V)	$R_{TOP}$ , $\pm 1\%$ (k $\Omega$ )	$R_{BOT}$ , $\pm 1\%$ (k $\Omega$ )
1.0	10	15
1.2	10	10
1.5	15	10
1.8	20	10
2.5	47.5	15
3.3	10	2.21
5.0	22	3

### VOLTAGE CONVERSION LIMITATIONS

The minimum output voltage for a given input voltage and switching frequency is constrained by the minimum on time. The minimum on time of the [ADP2323](#) is typically 130 ns. The minimum output voltage in CCM mode at a given input voltage and frequency can be calculated by using the following equation:

$$V_{OUT\_MIN} = V_{IN} \times t_{MIN\_ON} \times f_{SW} - (R_{DSON1} - R_{DSON2}) \times I_{OUT\_MIN} \times t_{MIN\_ON} \times f_{SW} - (R_{DSON2} + R_L) \times I_{OUT\_MIN}$$

where:

$V_{OUT\_MIN}$  is the minimum output voltage.

$t_{MIN\_ON}$  is the minimum on time.

$I_{OUT\_MIN}$  is the minimum output current.

$f_{SW}$  is the switching frequency.

$R_{DSON1}$  is the high-side MOSFET on resistance.

$R_{DSON2}$  is the low-side MOSFET on resistance.

$R_L$  is the series resistance of output inductor.

The maximum output voltage for a given input voltage and switching frequency is constrained by the minimum off time and the maximum duty cycle. The minimum off time is typically 150 ns and the maximum duty is typically 90% in the [ADP2323](#).

The maximum output voltage that is limited by the minimum off time at a given input voltage and frequency can be calculated using the following equation:

$$V_{OUT\_MAX} = V_{IN} \times (1 - t_{MIN\_OFF} \times f_{SW}) - (R_{DSON1} - R_{DSON2}) \times I_{OUT\_MAX} \times (1 - t_{MIN\_OFF} \times f_{SW}) - (R_{DSON2} + R_L) \times I_{OUT\_MAX}$$

where:

$V_{OUT\_MAX}$  is the maximum output voltage.

$t_{MIN\_OFF}$  is the minimum off time.

$I_{OUT\_MAX}$  is the maximum output current.

The maximum output voltage limited by the maximum duty cycle at a given input voltage can be calculated by using the following equation:

$$V_{OUT\_MAX} = D_{MAX} \times V_{IN}$$

where  $D_{MAX}$  is the maximum duty.

As the previous equations show, reducing the switching frequency alleviates the minimum on time and minimum off time limitation.

### CURRENT-LIMIT SETTING

The [ADP2323](#) has three selectable current-limit thresholds. Make sure that the selected current-limit value is larger than the peak current of the inductor,  $I_{PEAK}$ .

## INDUCTOR SELECTION

The inductor value is determined by the operating frequency, input voltage, output voltage, and inductor ripple current. Using a small inductor leads to a faster transient response but degrades efficiency due to larger inductor ripple current, whereas a large inductor value leads to smaller ripple current and better efficiency but results in a slower transient response. Thus, there is a trade-off between the transient response and efficiency. As a guideline, the inductor ripple current,  $\Delta I_L$ , is typically set to 1/3 of the maximum load current. The inductor value can be calculated using the following equation:

$$L = \frac{(V_{IN} - V_{OUT}) \times D}{\Delta I_L \times f_{SW}}$$

where:

$V_{IN}$  is the input voltage.

$V_{OUT}$  is the output voltage.

$\Delta I_L$  is the inductor ripple current.

$f_{SW}$  is the switching frequency.

$D$  is the duty cycle.

$$D = \frac{V_{OUT}}{V_{IN}}$$

The ADP2323 uses adaptive slope compensation in the current loop to prevent subharmonic oscillations when the duty cycle is larger than 50%. The internal slope compensation limits the minimum inductor value.

For a duty cycle that is larger than 50%, the minimum inductor value is determined by the following equation:

$$\frac{V_{OUT} \times (1 - D)}{2 \times f_{SW}}$$

The inductor peak current is calculated using the following equation:

$$I_{PEAK} = I_{OUT} + \frac{\Delta I_L}{2}$$

The saturation current of the inductor must be larger than the peak inductor current. For the ferrite core inductors with a quick saturation characteristic, the saturation current rating of the inductor should be higher than the current-limit threshold of the switch to prevent the inductor from getting into saturation.

The rms current of the inductor can be calculated by the following equation:

$$I_{RMS} = \sqrt{I_{OUT}^2 + \frac{\Delta I_L^2}{12}}$$

Shielded ferrite core materials are recommended for low core loss and low EMI.

Table 9. Recommended Inductors

Vendor	Part No.	Value [μH]	I <sub>SAT</sub> [A]	I <sub>RMS</sub> [A]	DCR [mΩ]
Sumida	CDRH105RNP-1R5N	1.5	10.5	8.3	5.8
	CDRH105RNP-2R2N	2.2	9.25	7.5	7.2
	CDRH105RNP-3R3N	3.3	7.8	6.5	10.4
	CDRH105RNP-4R7N	4.7	6.4	6.1	12.3
	CDRH105RNP-6R8N	6.8	5.4	5.4	18
Coilcraft	MSS1048-152NL	1.5	10.5	10.8	5.8
	MSS1048-222NL	2.2	8.4	9.78	7.2
	MSS1048-332NL	3.3	7.38	7.22	10.4
	MSS1048-472NL	4.7	6.46	6.9	12.3
	MSS1048-682NL	6.8	5.94	6.01	18
Würth Elektronik	7447797180	1.8	13.3	7.3	16
	7447797300	3.0	10.5	7.0	18
	7447797470	4.7	8.0	5.8	27
	7447797620	6.2	7.5	5.5	30

## OUTPUT CAPACITOR SELECTION

The output capacitor selection affects both the output voltage ripple and the loop dynamics of the regulator. For example, during load step transient on the output, when the load is suddenly increased, the output capacitor supplies the load until the control loop has a chance to ramp up the inductor current, which causes an undershoot of the output voltage.

Use the following equation to calculate the output capacitance that is required to meet the voltage droop requirement:

$$C_{OUT\_UV} = \frac{K_{UV} \times \Delta I_{STEP}^2 \times L}{2 \times (V_{IN} - V_{OUT}) \times \Delta V_{OUT\_UV}}$$

where:

$\Delta I_{STEP}$  is the load step.

$\Delta V_{OUT\_UV}$  is the allowable undershoot on the output voltage.

$K_{UV}$  is a factor, typically setting  $K_{UV} = 2$ .

Another case is when a load is suddenly removed from the output and the energy stored in the inductor rushes into the output capacitor, which causes the output to overshoot. The output capacitance required to meet the overshoot requirement can be calculated using the following equation:

$$C_{OUT\_OV} = \frac{K_{OV} \times \Delta I_{STEP}^2 \times L}{(V_{OUT} + \Delta V_{OUT\_OV})^2 - V_{OUT}^2}$$

where:

$\Delta V_{OUT\_OV}$  is the allowable overshoot on the output voltage.

$K_{OV}$  is a factor, typically setting  $K_{OV} = 2$ .

The output ripple is determined by the ESR of the output capacitor and its capacitance value. Use the following equation to select a capacitor that can meet the output ripple requirements:

$$C_{OUT\_RIPPLE} = \frac{\Delta I_L}{8 \times f_{SW} \times \Delta V_{OUT\_RIPPLE}}$$

$$R_{ESR} = \frac{\Delta V_{OUT\_RIPPLE}}{\Delta I_L}$$

where:

$\Delta V_{OUT\_RIPPLE}$  is the allowable output voltage ripple.

$R_{ESR}$  is the equivalent series resistance of the output capacitor.

Select the largest output capacitance given by  $C_{OUT\_UV}$ ,  $C_{OUT\_OV}$ , and  $C_{OUT\_RIPPLE}$  to meet both load transient and output ripple performance.

The selected output capacitor voltage rating must be greater than the output voltage. The minimum rms current rating of the output capacitor is determined by the following equation:

$$I_{C_{OUT\_rms}} = \frac{\Delta I_L}{\sqrt{12}}$$

### LOW-SIDE POWER DEVICE SELECTION

The ADP2323 has integrated low-side MOSFET drivers, which can drive the low-side N-channel MOSFETs (NFETs). The selection of the low-side N-channel MOSFET affects the dc-to-dc regulator performance.

The selected MOSFET must meet the following requirements:

- Drain source voltage ( $V_{DS}$ ) must be higher than  $1.2 \times V_{IN}$ .
- Drain current ( $I_D$ ) must be greater than the  $1.2 \times I_{LIMIT\_MAX}$ , where  $I_{LIMIT\_MAX}$  is the selected maximum current-limit threshold.

The ADP2323 low-side gate drive voltage is 5 V. Make sure that the selected MOSFET can be fully turned on at 5 V.

Total gate charge (Qg at 5 V) must be less than 30 nC. Lower Qg characteristics constitute higher efficiency.

When the high-side MOSFET is turned off, the low-side MOSFET carries the inductor current. For low duty cycle applications, the low-side MOSFET carries the current for most of the period. To achieve higher efficiency, it is important to select a low on-resistance MOSFET. The power conduction loss for the low-side MOSFET can be calculated using the following equation:

$$P_{FET\_LOW} = I_{OUT}^2 \times R_{DS(on)} \times (1 - D)$$

where  $R_{DS(on)}$  is the on resistance of the low-side MOSFET.

Make sure that the MOSFET can handle the thermal dissipation due to the power loss.

In some cases, efficiency is not critical for the system; therefore, the diode can be selected as the low-side power device. The average current of the diode can be calculated using the following equation:

$$I_{DIODE(AVG)} = (1 - D) \times I_{OUT}$$

The reverse breakdown voltage rating of the diode must be greater than the input voltage with an appropriate margin to allow for ringing, which may be present at the SWx node. A Schottky diode is recommended because it has low forward voltage drop and fast switching speed.

If a diode is used for the low-side device, the ADP2323 must enable the PFM mode by connecting the MODE pin to ground.

Table 10. Recommended MOSFETs

Vendor	Part No.	$V_{DS}$	$I_D$	$R_{DS(on)}$	Qg
Fairchild	FDS8880	30 V	10.7 A	12 m $\Omega$	12 nC
Fairchild	FDMS7578	25 V	14 A	8 m $\Omega$	8 nC
Fairchild	FDS6898A	20 V	9.4 A	14 m $\Omega$	16 nC
Vishay	Si4804CDY	30 V	7.9 A	27 m $\Omega$	7 nC
Vishay	SiA430DJ	20 V	10.8 A	18.5 m $\Omega$	5.3 nC
AOS	AON7402	30 V	39 A	15 m $\Omega$	7.1 nC
AOS	AO4884L	40 V	10 A	16 m $\Omega$	13.6 nC

### PROGRAMMING UVLO INPUT

The precision enable input can be used to program the UVLO threshold and hysteresis of the input voltage as shown in Figure 46.

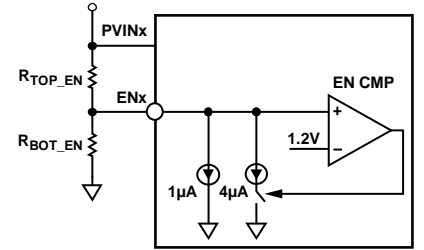

Figure 46. Programming UVLO Input

Use the following equation to calculate  $R_{TOP\_EN}$  and  $R_{BOT\_EN}$ :

$$R_{TOP\_EN} = \frac{1.1 V \times V_{IN\_RISING} - 1.2 V \times V_{IN\_FALLING}}{1.1 V \times 5 \mu A - 1.2 V \times 1 \mu A}$$

$$R_{BOT\_EN} = \frac{1.2 V \times R_{TOP\_EN}}{V_{IN\_RISING} - R_{TOP\_EN} \times 5 \mu A - 1.2 V}$$

where:

$V_{IN\_RISING}$  is the  $V_{IN}$  rising threshold.

$V_{IN\_FALLING}$  is the  $V_{IN}$  falling threshold.

### COMPENSATION COMPONENTS DESIGN

For peak current-mode control, the power stage can be simplified as a voltage controlled current source supplying current to the output capacitor and load resistor. It is composed of one domain pole and a zero contributed by the output capacitor ESR. The control-to-output transfer function is shown in the following equations:

$$G_{vd}(s) = \frac{V_{OUT}(s)}{V_{COMP}(s)} = A_{VI} \times R \times \left( \frac{1 + \frac{s}{2 \times \pi \times f_z}}{1 + \frac{s}{2 \times \pi \times f_p}} \right)$$

$$f_z = \frac{1}{2 \times \pi \times R_{ESR} \times C_{OUT}}$$

$$f_p = \frac{1}{2 \times \pi \times (R + R_{ESR}) \times C_{OUT}}$$

where:

$A_{VI} = 5 A/V$

$R$  is the load resistance.

$C_{OUT}$  is the output capacitance.

$R_{ESR}$  is the equivalent series resistance of the output capacitor.

The ADP2323 uses a transconductance amplifier for the error amplifier to compensate the system. Figure 47 shows the simplified peak current-mode control small signal circuit.

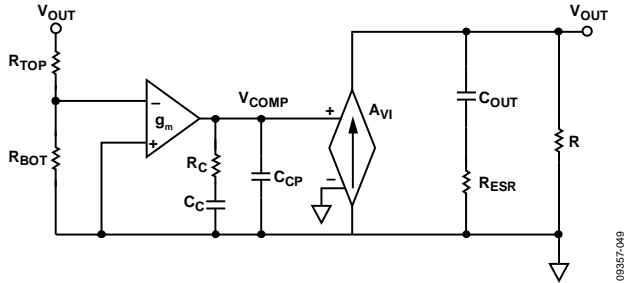

Figure 47. Simplified Peak Current-Mode Control Small Signal Circuit

The compensation components,  $R_C$  and  $C_C$ , contribute a zero, and the optional  $C_{CP}$  and  $R_C$  contribute an optional pole.

The closed-loop transfer equation is as follows:

$$T_V(s) = \frac{R_{BOT}}{R_{BOT} + R_{TOP}} \times \frac{-g_m}{C_C + C_{CP}} \times \frac{1 + R_C \times C_C \times s}{s \times \left( 1 + \frac{R_C \times C_C \times C_{CP} \times s}{C_C + C_{CP}} \right)} \times G_{vd}(s)$$

The following design guideline shows how to select the compensation components,  $R_C$ ,  $C_C$ , and  $C_{CP}$ , for ceramic output capacitor applications.

1. Determine the cross frequency ( $f_C$ ). Generally, the  $f_C$  is between  $f_{SW}/12$  and  $f_{SW}/6$ .
2.  $R_C$  can be calculated using the following equation:

$$R_C = \frac{2 \times \pi \times V_{OUT} \times C_{OUT} \times f_C}{0.6 \text{ V} \times g_m \times A_{VI}}$$

3. Place the compensation zero at the domain pole ( $f_p$ ).  $C_C$  can be determined by

$$C_C = \frac{(R + R_{ESR}) \times C_{OUT}}{R_C}$$

4.  $C_{CP}$  is optional. It can be used to cancel the zero caused by the ESR of the output capacitor.

$$C_{CP} = \frac{R_{ESR} \times C_{OUT}}{R_C}$$

The ADP2323 has a 10 pF capacitor internally at the COMPx pin; therefore, if  $C_{CP}$  is smaller than 10 pF, no external capacitor is needed.

## DESIGN EXAMPLE

This section explains design procedure and component selection as shown in Figure 50; Table 11 provides a list of the required settings.

**Table 11. Dual Step-Down DC-to-DC Regulator Requirements**

Parameter	Specification
<b>Channel 1</b>	
Input Voltage	$V_{IN1} = 12.0\text{ V} \pm 10\%$
Output Voltage	$V_{OUT1} = 1.2\text{ V}$
Output Current	$I_{OUT1} = 3\text{ A}$
Output Voltage Ripple	$\Delta V_{OUT1\_RIPPLE} = 12\text{ mV}$
Load Transient	$\pm 5\%$ , 0.5 A to 3A, 1 A/ $\mu\text{s}$
<b>Channel 2</b>	
Input Voltage	$V_{IN2} = 12.0\text{ V} \pm 10\%$
Output Voltage	$V_{OUT2} = 3.3\text{ V}$
Output Current	$I_{OUT2} = 3\text{ A}$
Output Voltage Ripple	$\Delta V_{OUT2\_RIPPLE} = 33\text{ mV}$
Load Transient	$\pm 5\%$ , 0.5 A to 3 A, 1 A/ $\mu\text{s}$
Switching Frequency	$f_{SW} = 500\text{ kHz}$

### OUTPUT VOLTAGE SETTING

Choose a 10 k $\Omega$  top feedback resistor ( $R_{TOP}$ ); calculate the bottom feedback resistor by using the following equation:

$$R_{BOT} = R_{TOP} \times \left( \frac{0.6}{V_{OUT} - 0.6} \right)$$

To set the output voltage to 1.2 V, the resistor values are  $R_{TOP1} = 10\text{ k}\Omega$  and  $R_{BOT1} = 10\text{ k}\Omega$ . To set the output voltage to 3.3 V, the resistors values are  $R_{TOP2} = 10\text{ k}\Omega$  and  $R_{BOT2} = 2.21\text{ k}\Omega$ .

### CURRENT-LIMIT SETTING

For 3 A output current operation, the typical peak current limit is 4.8 A. In this case, no  $R_{ILIM}$  is required.

### FREQUENCY SETTING

To set the switching frequency to 500 kHz, use the following equation to calculate the resistor value,  $R_{OSC}$ :

$$R_{OSC} (\text{k}\Omega) = \frac{60,000}{f_{SW} (\text{kHz})}$$

Therefore,  $R_{OSC} = 100\text{ k}\Omega$ .

### INDUCTOR SELECTION

The peak-to-peak inductor ripple current,  $\Delta I_L$ , is set to 30% of the maximum output current. Use the following equation to estimate the value of the inductor:

$$L = \frac{(V_{IN} - V_{OUT}) \times D}{\Delta I_L \times f_{SW}}$$

For  $V_{OUT1} = 1.2\text{ V}$ , Inductor L1 = 2.4  $\mu\text{H}$ , and for  $V_{OUT2} = 3.3\text{ V}$ , Inductor L2 = 5.3  $\mu\text{H}$ .

Select the standard inductor value of 2.2  $\mu\text{H}$  and 4.7  $\mu\text{H}$  for the 1.2 V and 3.3 V rails.

Calculate the peak-to-peak inductor ripple current as follows:

$$\Delta I_L = \frac{(V_{IN} - V_{OUT}) \times D}{L \times f_{SW}}$$

For  $V_{OUT1} = 1.2\text{ V}$ ,  $\Delta I_{L1} = 0.98\text{ A}$ . For  $V_{OUT2} = 3.3\text{ V}$ ,  $\Delta I_{L2} = 1.02\text{ A}$ .

Find the peak inductor current by using the following equation:

$$I_{PEAK} = I_{OUT} + \frac{\Delta I_L}{2}$$

For the 1.2 V rail, the peak inductor current is 3.49 A, and for the 3.3 V rail, the peak inductor current is 3.51 A.

The rms current through the inductor can be estimated by

$$I_{RMS} = \sqrt{I_{OUT}^2 + \frac{\Delta I_L^2}{12}}$$

The rms current of the inductor for both 1.2 V and 3.3 V is approximately 3.01 A.

For the 1.2 V rail, select an inductor with a minimum rms current rating of 3.01 A and a minimum saturation current rating of 3.49 A. For the 3.3 V rail, select an inductor with a minimum rms current rating of 3.01 A and a minimum saturation current rating of 3.51 A.

Based on these requirements, for the 1.2 V rail, select a 2.2  $\mu\text{H}$  inductor, such as the Sumida CDRH105RNP-2R2N, with a DCR = 7.2 m $\Omega$ ; for the 3.3 V rail, select a 4.7  $\mu\text{H}$  inductor, such as the Sumida CDRH105RNP-4R7N, with a DCR = 12.3 m $\Omega$ .

### OUTPUT CAPACITOR SELECTION

The output capacitor is required to meet the output voltage ripple and load transient requirement. To meet the output voltage ripple requirement, use the following equation to calculate the ESR and capacitance:

$$C_{OUT\_RIPPLE} = \frac{\Delta I_L}{8 \times f_{SW} \times \Delta V_{OUT\_RIPPLE}}$$

$$R_{ESR} = \frac{\Delta V_{OUT\_RIPPLE}}{I_L}$$

For  $V_{OUT1} = 1.2\text{ V}$ ,  $C_{OUT\_RIPPLE1} = 20\text{ }\mu\text{F}$  and  $R_{ESR1} = 12\text{ m}\Omega$ . For  $V_{OUT2} = 3.3\text{ V}$ ,  $C_{OUT\_RIPPLE2} = 7.7\text{ }\mu\text{F}$  and  $R_{ESR2} = 32\text{ m}\Omega$ .

To meet the  $\pm 5\%$  overshoot and undershoot requirement, use the following equation to calculate the capacitance:

$$C_{OUT\_OV} = \frac{K_{OV} \times \Delta I_{STEP}^2 \times L}{(V_{OUT} + \Delta V_{OUT\_OV})^2 - V_{OUT}^2}$$

$$C_{OUT\_UV} = \frac{K_{UV} \times \Delta I_{STEP}^2 \times L}{2 \times (V_{IN} - V_{OUT}) \times \Delta V_{OUT\_UV}}$$

For estimation purposes, use  $K_{OV} = K_{UV} = 2$ . For  $V_{OUT1} = 1.2\text{ V}$ , use  $C_{OUT\_OV1} = 191\text{ }\mu\text{F}$  and  $C_{OUT\_UV1} = 21\text{ }\mu\text{F}$ . For  $V_{OUT2} = 3.3\text{ V}$ , use  $C_{OUT\_OV2} = 54\text{ }\mu\text{F}$  and  $C_{OUT\_UV2} = 20\text{ }\mu\text{F}$ .

For the 1.2 V rail, the output capacitor ESR needs to be smaller than 12 mΩ, and the output capacitance needs to be larger than 191 μF. It is recommended that three pieces of 100 μF/X5R/6.3 V ceramic capacitor be used, such as the GRM32ER60J107ME20 from Murata, with an ESR = 2 mΩ.

For the 3.3 V rail, the ESR of the output capacitor must be smaller than 32 mΩ and the output capacitance must be larger than 54 μF. It is recommended that two pieces of 47 μF/X5R/6.3 V ceramic capacitor be used, such as the Murata GRM32ER60J476ME20, with an ESR = 2 mΩ.

### LOW-SIDE MOSFET SELECTION

A low  $R_{DS(ON)}$  N-channel MOSFET is selected for high efficiency solutions. The MOSFET breakdown voltage needs to be greater than  $1.2 \text{ V} \times V_{IN}$ , and the drain current needs to be greater than  $1.2 \text{ V} \times I_{LIMIT}$ .

It is recommended that a 30 V, N-channel MOSFET be used, such as the FDS8880 from Fairchild. The  $R_{DS(ON)}$  of the FDS8880 at a 4.5 V driver voltage is 12 mΩ, and the total gate charge is 12 nC.

### COMPENSATION COMPONENTS

For better load transient and stability performance, set the cross frequency,  $f_c$ , to  $f_{SW}/10$ . In this case,  $f_{SW}$  is running at 500 kHz; therefore, the  $f_c$  is set to 50 kHz.

For the 1.2 V rail, the 100 μF ceramic output capacitor has a derated value of 64 μF.

$$R_{C1} = \frac{2 \times \pi \times 1.2 \text{ V} \times 3 \times 64 \mu\text{F} \times 50 \text{ kHz}}{0.6 \text{ V} \times 300 \mu\text{s} \times 5 \text{ A/V}} = 80.4 \text{ k}\Omega$$

$$C_{C1} = \frac{(0.4 \Omega + 0.001 \Omega) \times 3 \times 64 \mu\text{F}}{80.4 \text{ k}\Omega} = 957 \text{ pF}$$

$$C_{CP1} = \frac{0.001 \Omega \times 3 \times 64 \mu\text{F}}{80.4 \text{ k}\Omega} = 2.4 \text{ pF}$$

Choose standard components,  $R_{C1} = 82 \text{ k}\Omega$  and  $C_{C1} = 1000 \text{ pF}$ . No  $C_{CP1}$  is needed.

Figure 48 shows the 1.2 V rail bode plot at 3 A. The cross frequency is 49 kHz and the phase margin is 59°.

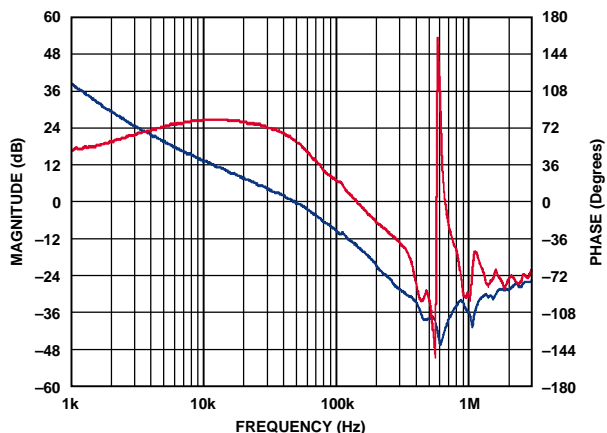

Figure 48. Bode Plot for 1.2 V Rail

For the 3.3 V rail, the 47 μF ceramic output capacitor has a derated value of 32 μF.

$$R_{C2} = \frac{2 \times \pi \times 3.3 \text{ V} \times 2 \times 32 \mu\text{F} \times 50 \text{ kHz}}{0.6 \text{ V} \times 300 \mu\text{s} \times 5 \text{ A/V}} = 73.7 \text{ k}\Omega$$

$$C_{C2} = \frac{(1.1 \Omega + 0.001 \Omega) \times 2 \times 32 \mu\text{F}}{73.7 \text{ k}\Omega} = 956 \text{ pF}$$

$$C_{CP2} = \frac{0.001 \Omega \times 2 \times 32 \mu\text{F}}{73.7 \text{ k}\Omega} = 1 \text{ pF}$$

Choose standard component values of  $R_{C2} = 75 \text{ k}\Omega$  and  $C_{C2} = 1000 \text{ pF}$ . No  $C_{CP2}$  is needed.

Figure 49 shows the 3.3 V rail bode plot at 3 A. The cross frequency is 59 kHz and phase margin is 61°.

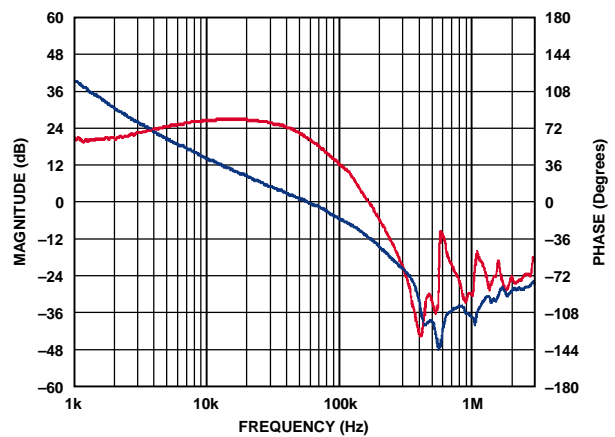

Figure 49. Bode Plot for 3.3 V Rail

### SOFT START TIME PROGRAMMING

The soft start feature allows the output voltage to ramp up in a controlled manner, eliminating output voltage overshoot during soft start and limiting inrush current. The soft start time is set to 3 ms.

$$C_{SS} = \frac{I_{SS} \times T_{SS}}{0.6 \text{ V}} = \frac{3.5 \mu\text{A} \times 3 \text{ ms}}{0.6 \text{ V}} = 17.5 \text{ nF}$$

Choose a standard component value of  $C_{SS1} = C_{SS2} = 22 \text{ nF}$ .

### INPUT CAPACITOR SELECTION

A minimum 10 μF ceramic capacitor is required, placed near the PVINx pin. In this application, one piece of 10 μF, X5R, 25 V ceramic capacitor is recommended.

## EXTERNAL COMPONENTS RECOMMENDATION

Table 12. Recommended External Components for Typical Applications with 3 A Output Current

$f_{SW}$ (kHz)	$V_{IN}$ (V)	$V_{OUT}$ (V)	L ( $\mu$ H)	$C_{OUT}$ ( $\mu$ F) <sup>1</sup>	$R_{TOP}$ (k $\Omega$ )	$R_{BOT}$ (k $\Omega$ )	$R_C$ (k $\Omega$ )	$C_C$ (pF)	$C_{CP}$ (pF)
300	12	1	3.3	330	10	15	62	1500	33
	12	1.2	4.7	330	10	10	82	1500	22
	12	1.5	4.7	330	15	10	100	1500	22
	12	1.8	4.7	2 × 100	20	10	47	1500	4.7
	12	2.5	6.8	100 + 47	47.5	15	47	1500	4.7
	12	3.3	10	100 + 47	10	2.21	62	1500	3.3
	12	5	10	100	22	3	62	1500	2.2
	5	1	3.3	330	10	15	62	1500	33
	5	1.2	3.3	330	10	10	82	1500	22
	5	1.5	3.3	330	15	10	100	1500	22
	5	1.8	4.7	2 × 100	20	10	47	1500	4.7
	5	2.5	4.7	100 + 47	47.5	15	47	1500	4.7
	5	3.3	4.7	100	10	2.21	47	1500	3.3
	600	12	1.5	2.2	2 × 100	15	10	82	820
12		1.8	3.3	100 + 47	20	10	75	820	3.3
12		2.5	3.3	2 × 47	47.5	15	62	820	2.2
12		3.3	4.7	2 × 47	10	2.21	82	820	2.2
12		5	4.7	47	22	3	62	820	2.2
5		1	1.5	2 × 100	10	15	56	820	2.2
5		1.2	1.5	2 × 100	10	10	62	820	2.2
5		1.5	2.2	100 + 47	15	10	62	820	2.2
5		1.8	2.2	2 × 47	20	10	47	820	2.2
5		2.5	2.2	2 × 47	47.5	15	62	820	2.2
5		3.3	2.2	2 × 47	10	2.21	82	820	2.2
1000		12	1.8	1.5	100	20	10	82	470
	12	2.5	2.2	47	47.5	15	56	470	2.2
	12	3.3	2.2	47	10	2.21	68	470	2.2
	12	5	3.3	47	22	3	100	470	2.2
	5	1	1	2 × 100	10	15	82	470	2.2
	5	1.2	1	100 + 47	10	10	82	470	2.2
	5	1.5	1	2 × 47	15	10	68	470	2.2
	5	1.8	1	2 × 47	20	10	82	470	2.2
	5	2.5	1	47	47.5	15	56	470	2.2
	5	3.3	1	47	10	2.21	62	470	2.2

<sup>1</sup> 330  $\mu$ F: 6.3 V, Sanyo 6TPD330M; 100  $\mu$ F: 6.3 V, X5R, Murata GRM32ER60J107ME20; 47  $\mu$ F: 6.3 V, X5R, Murata GRM32ER60J476ME20.

TYPICAL APPLICATION CIRCUITS

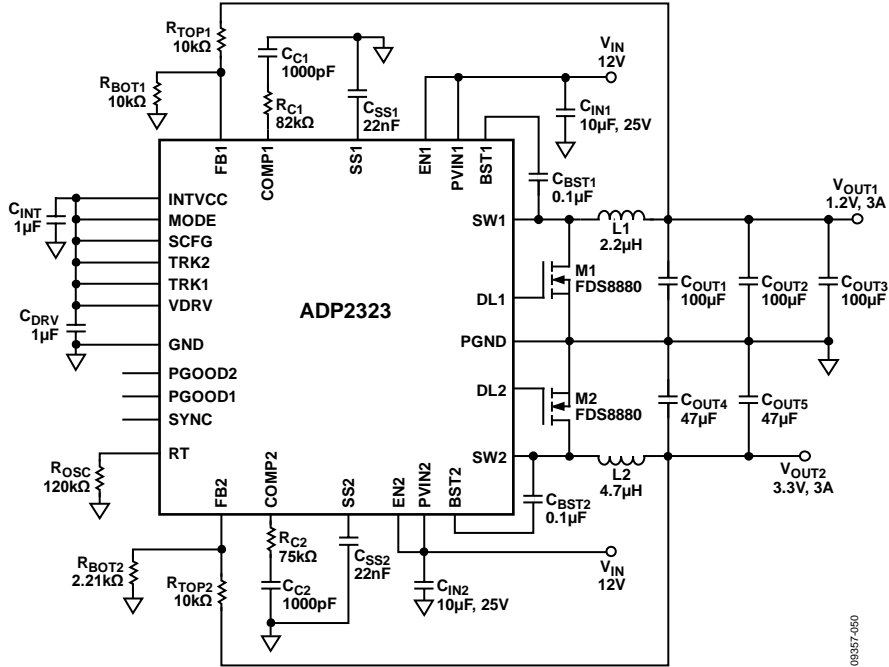

Figure 50. Using External MOSFET Application,  $V_{IN1} = V_{IN2} = 12\text{ V}$ ,  $V_{OUT1} = 1.2\text{ V}$ ,  $I_{OUT1} = 3\text{ A}$ ,  $V_{OUT2} = 3.3\text{ V}$ ,  $I_{OUT2} = 3\text{ A}$ ,  $f_{SW} = 500\text{ kHz}$

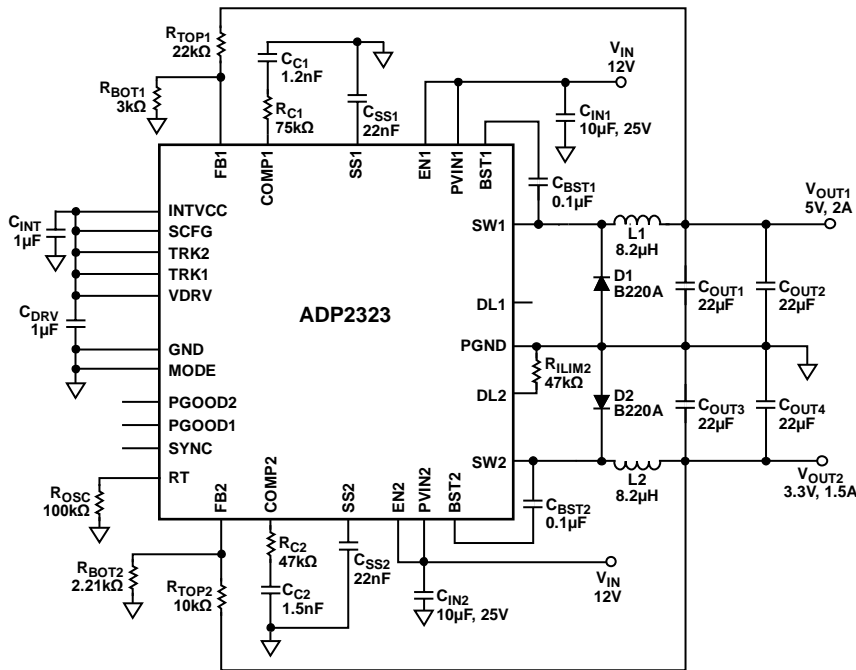

Figure 51. Using External Diode Application,  $V_{IN1} = V_{IN2} = 12\text{ V}$ ,  $V_{OUT1} = 5\text{ V}$ ,  $I_{OUT1} = 2\text{ A}$ ,  $V_{OUT2} = 3.3\text{ V}$ ,  $I_{OUT2} = 1.5\text{ A}$ ,  $f_{SW} = 600\text{ kHz}$

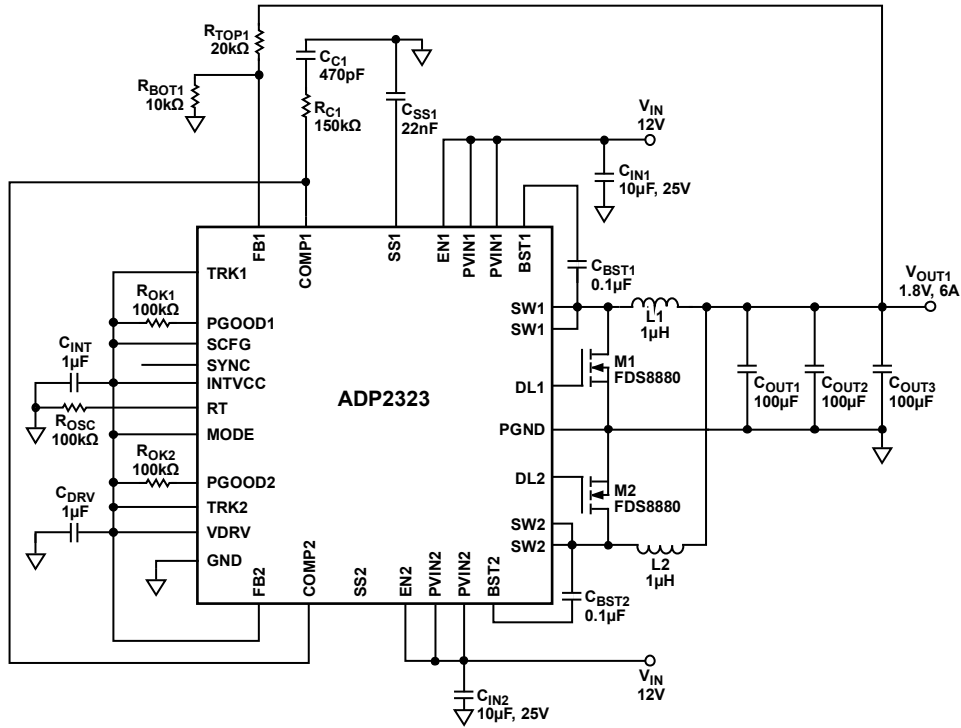

Figure 52. Parallel Single Output Application,  $V_{IN} = 12\text{ V}$ ,  $V_{OUT} = 1.8\text{ V}$ ,  $I_{OUT} = 6\text{ A}$ ,  $f_{SW} = 600\text{ kHz}$

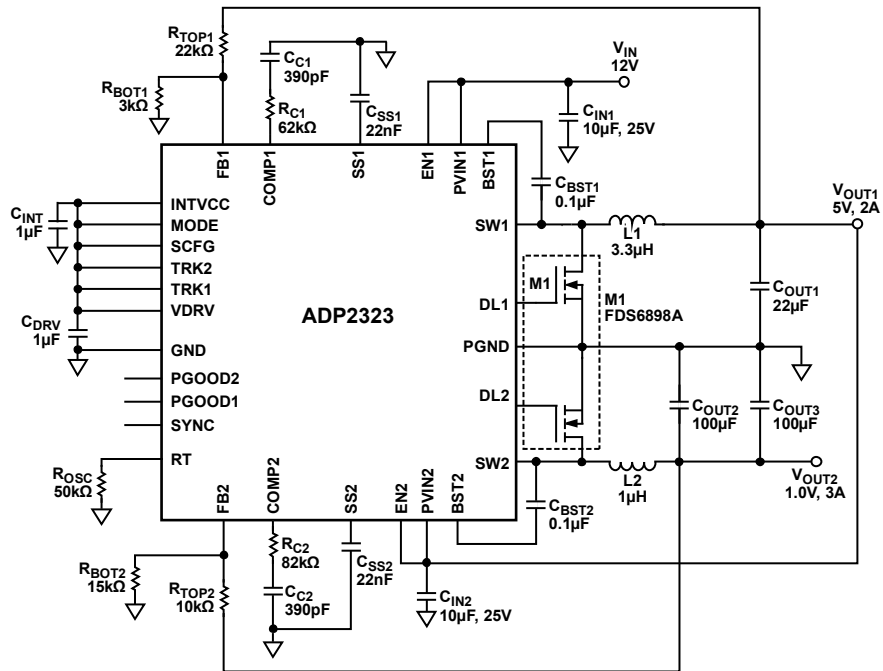

Figure 53. Cascading Supply Application,  $V_{IN1} = 12\text{ V}$ ,  $V_{OUT1} = 5\text{ V}$ ,  $I_{OUT1} = 2\text{ A}$ ,  $V_{OUT2} = 1\text{ V}$ ,  $I_{OUT2} = 3\text{ A}$ ,  $f_{SW} = 1.2\text{ MHz}$

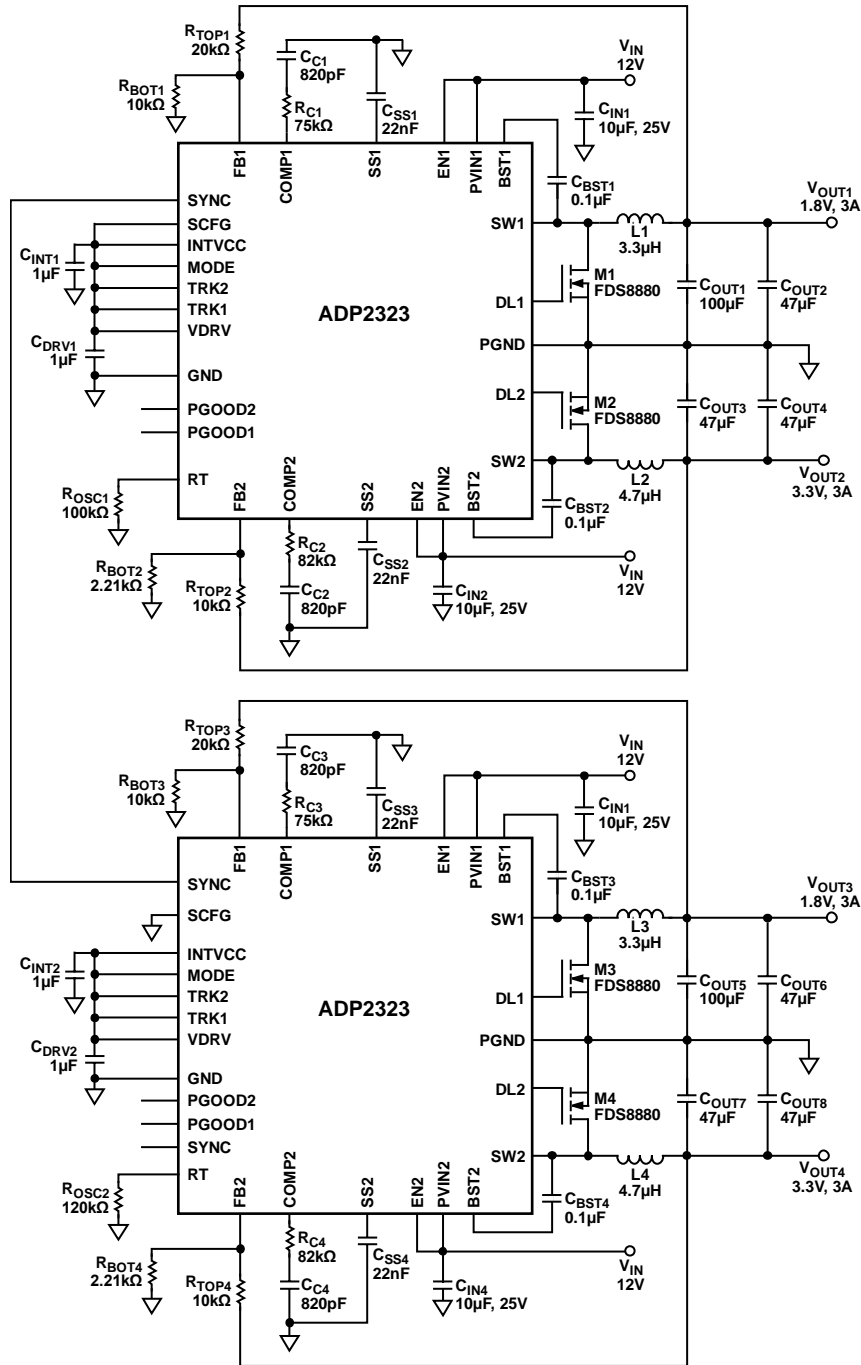

Figure 54. Synchronization with 90° Phase Shift Between Each Channel

09357-954

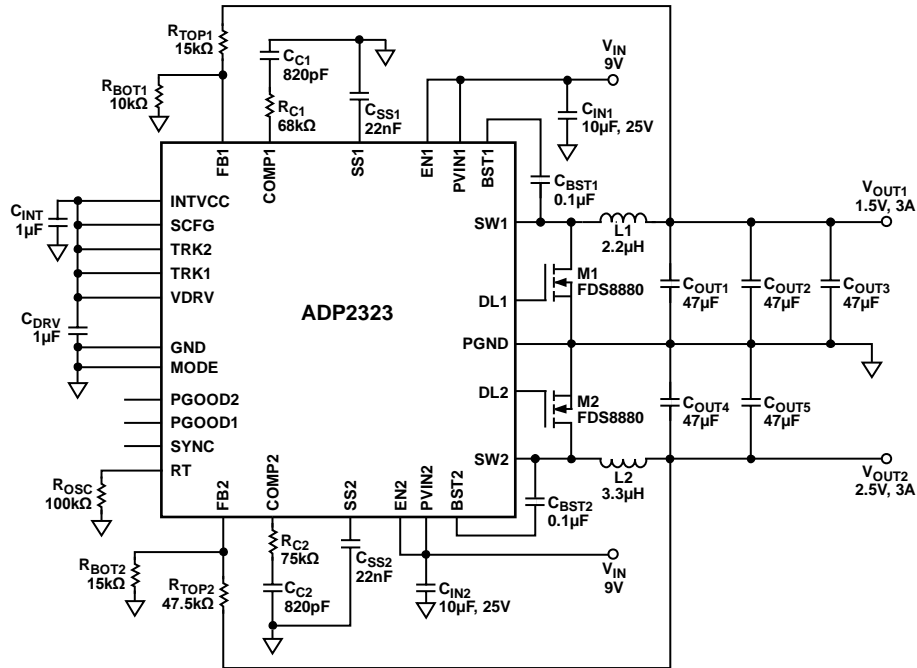

Figure 55. Enable PFM Mode with MODE Pin Pulled to GND,  $V_{IN1} = V_{IN2} = 9V$ ,  $V_{OUT1} = 1.5V$ ,  $I_{OUT1} = 3A$ ,  $V_{OUT2} = 2.5V$ ,  $I_{OUT2} = 3A$ ,  $f_{SW} = 600kHz$

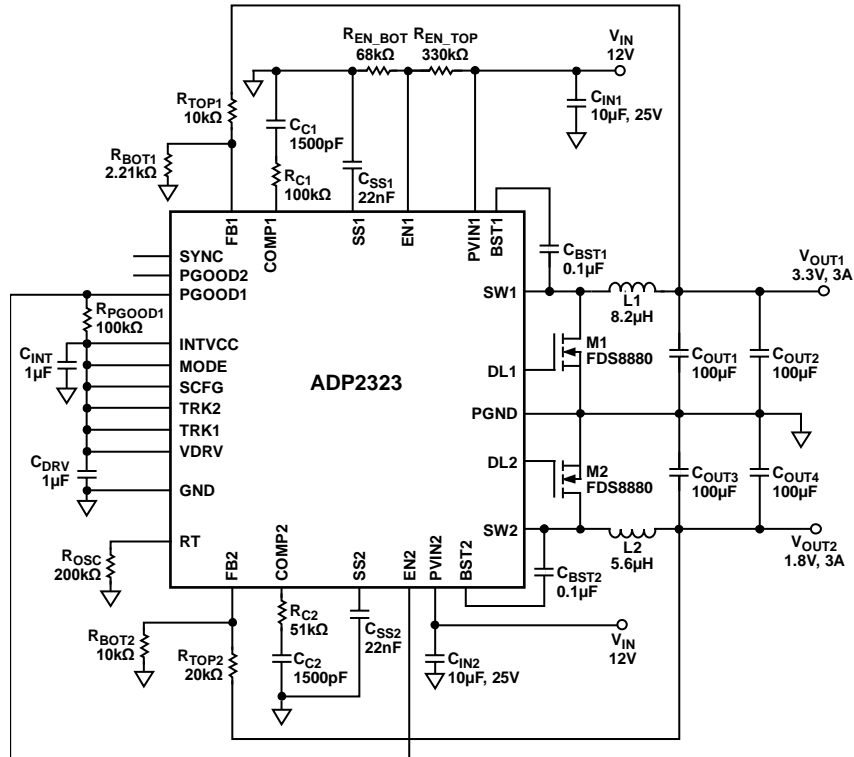
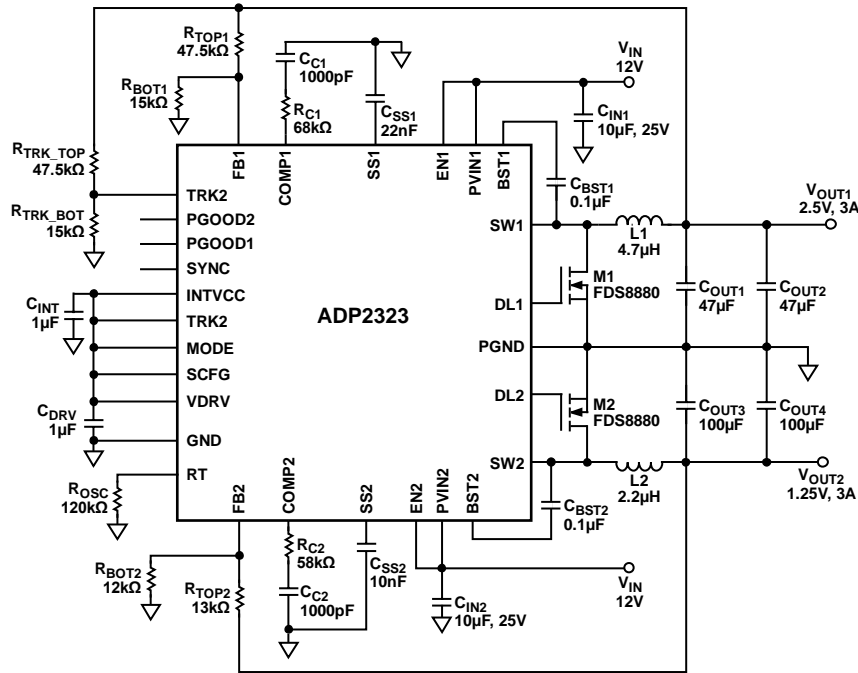

Figure 56. Programmable  $V_{IN\_RISING} = 8.7V$ ,  $V_{IN\_FALLING} = 6.7V$ , 3.3V Start Up Before 1.8V,  $V_{IN1} = V_{IN2} = 12V$ ,  $V_{OUT1} = 3.3V$ ,  $I_{OUT1} = 3A$ ,  $V_{OUT2} = 1.8V$ ,  $I_{OUT2} = 3A$ ,  $f_{SW} = 300kHz$



09S67-167

Figure 57. Channel 2 Tracking with Channel 1  
 $V_{IN1} = V_{IN2} = 12\text{ V}$ ,  $V_{OUT1} = 2.5\text{ V}$ ,  $I_{OUT1} = 3\text{ A}$ ,  $V_{OUT2} = 1.25\text{ V}$ ,  $I_{OUT2} = 3\text{ A}$ ,  $f_{SW} = 500\text{ kHz}$

### OUTLINE DIMENSIONS

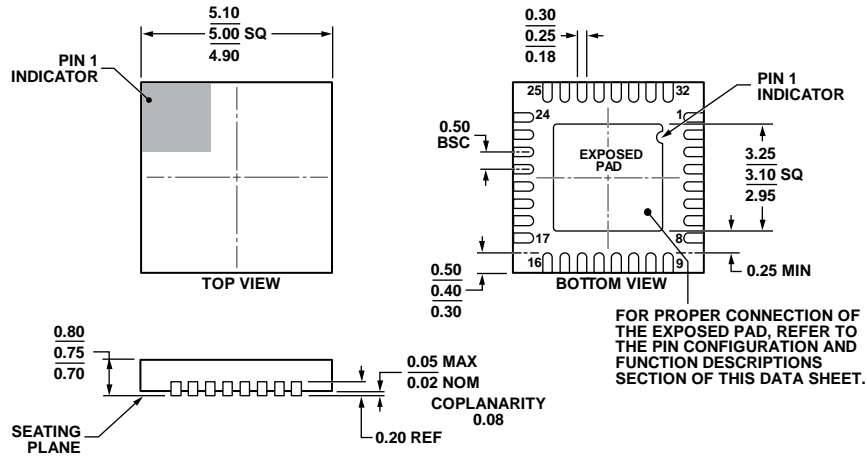

COMPLIANT TO JEDEC STANDARDS MO-220-WHHD.  
 Figure 58. 32-Lead Lead Frame Chip Scale Package [LFCSP\_WQ]  
 5 mm × 5 mm Body, Very Very Thin Quad  
 (CP-32-7)  
 Dimensions shown in millimeters

112408-A

### ORDERING GUIDE

Model <sup>1</sup>	Temperature Range	Output Voltage	Package Description	Package Option
ADP2323ACPZ-R7	-40°C to +125°C	Adjustable	32-Lead LFCSP_WQ	CP-32-7
ADP2323-EVALZ			Evaluation Board	

<sup>1</sup> Z = RoHS Compliant Part.

**NOTES**

## Looking for pricing, stock, or lifecycle information?

Click below to explore more details on WIN SOURCE:

 [View ADP2323ACPZ-R7 on WIN SOURCE](#)

 [Analog Devices Inc. Information](#)

## Optimize Your Supply Chain with WIN SOURCE Solutions

-  Global Sourcing Solution
-  Obsolete Management
-  Cost Control Management
-  Shortage Management
-  Alternative Solution
-  Excess Inventory Management