



THE DATASHEET OF ST3232BWR



3 to 5.5 V, low-power, up to 400 kbs RS-232 drivers and receivers

Datasheet - production data

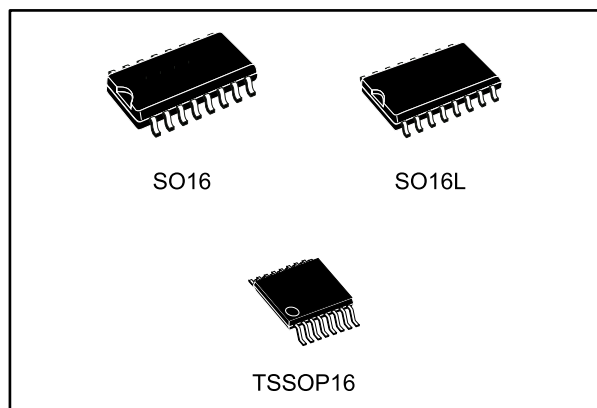

The ST3232B and ST3232C have two receivers and two drivers.

The devices are guaranteed to run at data rates of 250 kbps while maintaining RS-232 output levels. Typical applications are notebooks, subnotebooks and palmtop computers, battery-powered equipment, hand-held equipment, peripherals, and printers.

Table 1: Device summary

Order code	Temp. range	Package	Packaging
ST3232CDR	0 to 70 °C	SO16 (tape and reel)	2500 parts per reel
ST3232BDR	-40 to 85 °C		
ST3232CWR	0 to 70 °C	SO16L (tape and reel)	1000 parts per reel
ST3232BWR	-40 to 85 °C		
ST3232CTR	0 to 70 °C	TSSOP16 (tape and reel)	2500 parts per reel
ST3232BTR	-40 to 85 °C		

Features

- 300 μ A supply current
- 300 kbps minimum guaranteed data rate
- 6 V/ μ s minimum guaranteed slew rate
- Meets EIA/TIA-232 specifications down to 3 V
- Available in SO16, SO16L, and TSSOP16 packages

Description

The ST3232B and ST3232C devices are 3 V powered EIA/TIA-232 and V.28/V.24 communication interfaces with low power requirements and high data-rate capabilities.

These devices have a proprietary low dropout transmitter output stage providing true RS-232 performance from 3 to 5.5 V supplies. The devices require only four small 0.1 mF standard external capacitors for operation from a 3 V supply.

Contents

1 Pin configuration 3

2 Absolute maximum ratings..... 4

3 Electrical characteristics 5

4 Application information 7

5 Typical performance characteristics 8

6 Package information 10

 6.1 SO16 package information..... 11

 6.2 SO16L package information..... 12

 6.3 TSSOP16 package information..... 13

 6.4 SO16 tape and reel package information 14

 6.5 SO16L tape and reel package information 15

 6.6 TSSOP16 tape and reel package information 16

7 Revision history 17



1 Pin configuration

Figure 1: Pin connections

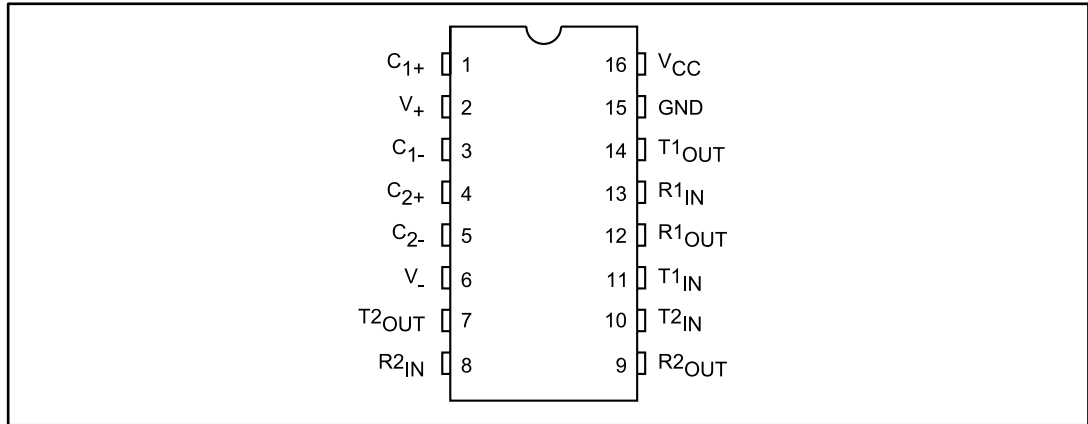

Table 2: Pin description

Pin n°	Symbol	Name and function
1	C_{1+}	Positive terminal for the first charge pump capacitor
2	V_{+}	Doubled voltage terminal
3	C_{1-}	Negative terminal for the first charge pump capacitor
4	C_{2+}	Positive terminal for the second charge pump capacitor
5	C_{2-}	Negative terminal for the second charge pump capacitor
6	V_{-}	Inverted voltage terminal
7	$T2_{OUT}$	Second transmitter output voltage
8	$R2_{IN}$	Second receiver input voltage
9	$R2_{OUT}$	Second receiver output voltage
10	$T2_{IN}$	Second transmitter input voltage
11	$T1_{IN}$	First transmitter input voltage
12	$R1_{OUT}$	First receiver output voltage
13	$R1_{IN}$	First receiver input voltage
14	$T1_{OUT}$	First transmitter output voltage
15	GND	Ground
16	V_{CC}	Supply voltage

2 Absolute maximum ratings

Table 3: Absolute maximum ratings

Symbol	Parameter	Value	Unit
V_{CC}	Supply voltage	-0.3 to 6	V
V+	Doubled voltage terminal	$(V_{CC} - 0.3)$ to 7	
V-	Inverted voltage terminal	0.3 to -7	
$V+ + V- $		13	
T_{IN}	Transmitter input voltage range	-0.3 to 6	
R_{IN}	Receiver input voltage range	± 25	
T_{OUT}	Transmitter output voltage range	± 13.2	
R_{OUT}	Receiver output voltage range	-0.3 to $(V_{CC} + 0.3)$	
t_{SHORT}	Transmitter output short to gnd time	Continuous	
T_{stg}	Storage temperature	-65 to 150	°C



Absolute maximum ratings are those values beyond which damage to the device may occur. Functional operation under these condition is not implied.

Externally applied V+ and V- can have a maximum magnitude of +7 V, but their absolute addition can not exceed 13 V.

Running on internal charge pump, intrinsic self limitation allows exceeding those values without any damage.

Startup voltage sequence (V_{CC} , then V+, then V-) is critical, therefore it is not recommended to use this device using externally applied voltage to V+ and V-.

3 Electrical characteristics

Table 4: Electrical characteristics (C1 - C4 = 0.1 μ F, VCC = 3 V to 5.5 V, TA = -40 to 85 °C, unless otherwise specified. Typical values are referred to TA = 25 °C)

Symbol	Parameter	Test conditions	Min.	Typ.	Max.	Unit
I _{SUPPLY}	V _{CC} power supply current	No load, V _{CC} = 3 V \pm 10 %, T _A = 25 °C		0.3	1	mA
		No load, V _{CC} = 5 V \pm 10 %, T _A = 25 °C		1	2	

Table 5: Logic input (C1 - C4 = 0.1 μ F, VCC = 3 V to 5.5 V, TA = -40 to 85 °C, unless otherwise specified. Typical values are referred to TA = 25 °C)

Symbol	Parameter	Test conditions	Min.	Typ.	Max.	Unit
V _{TIL}	Input logic threshold low	T-IN ⁽¹⁾			0.8	V
V _{TIH}	Input logic threshold high	V _{CC} = 3.3 V	2			
		V _{CC} = 5 V	2.4			
I _{IL}	Input leakage current	T-IN		\pm 0.01	\pm 1	μ A

Notes:

⁽¹⁾Transmitter input hysteresis is typically 250 mV.

Table 6: Transmitter (C1 - C4 = 0.1 μ F tested at 3.3 V \pm 10 %, VCC = 3 V to 5.5 V, TA = -40 to 85 °C, unless otherwise specified. Typical values are referred to TA = 25 °C)

Symbol	Parameter	Test conditions	Min.	Typ.	Max.	Unit
V _{TOUT}	Output voltage swing	All transmitter outputs are loaded with 3 k Ω to GND	\pm 5	\pm 5.4		V
R _{TOUT}	Transmitter output resistance	V _{CC} = V ₊ = V ₋ = 0 V, V _{OUT} = \pm 2 V	300	10 M		Ω
I _{TSC}	Output short circuit current	V _{CC} = 3 V or 5 V, V _{OUT} = \pm 12			\pm 60	mA

Table 7: Receiver (C1 - C4 = 0.1 μ F tested at 3.3 V \pm 10 %, VCC = 3 V to 5.5 V, TA = -40 to 85 °C, unless otherwise specified. Typical values are referred to TA = 25 °C)

Symbol	Parameter	Test conditions	Min.	Typ.	Max.	Unit
V _{RIN}	Receiver input voltage operating range		-25		25	V
V _{RIL}	RS-232 Input threshold low	T _A = 25 °C, V _{CC} = 3.3 V	0.6	1.1		
		T _A = 25 °C, V _{CC} = 5 V	0.8	1.5		
V _{RIH}	RS-232 Input threshold high	T _A = 25 °C, V _{CC} = 3.3 V		1.5	2.4	
		T _A = 25 °C, V _{CC} = 5 V		1.8	2.4	
V _{RIHYS}	Input hysteresis			0.3		
R _{RIN}	Input resistance	T _A = 25 °C	3	5	7	k Ω
V _{ROL}	TTL/CMOS output voltage low	I _{OUT} = 1.6 mA			0.4	V
V _{ROH}	TTL/CMOS output voltage high	I _{OUT} = -1 mA	V _{CC} - 0.6	V _{CC} - 0.1		

Table 8: Timing characteristics (C1 - C4 = 0.1 μ F tested at 3.3 V \pm 10 %, VCC = 3 V to 5.5 V, TA = -40 to 85 $^{\circ}$ C, unless otherwise specified. Typical values are referred to TA = 25 $^{\circ}$ C)

Symbol	Parameter	Test conditions	Min.	Typ.	Max.	Unit
D _R	Data transfer rate	R _L = 3 k Ω , C _{L2} = 1000 pF one transmitter switching	300	400		kbps
t _{PHLR} , t _{PLHR}	Propagation delay input to output	R _{XIN} = R _{XOUT} , C _L = 150 pF		0.2		μ s
t _{PHLT} - t _{THL}	Transmitter propagation delay difference	See ⁽¹⁾		100		ns
t _{PHLR} - t _{THR}	Receiver propagation delay difference			50		
S _{RT}	Transition slew rate	T _A = 25 $^{\circ}$ C, R _L = 3 k Ω to 7 k Ω , V _{CC} = 3.3 V measured from 3 V to -3 V or -3 V to 3 V, C _L = 150 pF to 1000 pF	6		30	V/ μ s
		T _A = 25 $^{\circ}$ C, R _L = 3 k Ω to 7 k Ω , V _{CC} = 3.3 V measured from 3 V to -3 V or -3 V to 3 V, C _L = 150 pF to 2500 pF	4		30	

Notes:

⁽¹⁾Transmitter skew is measured at the transmitter zero cross points

4 Application information

Figure 2: Application circuits

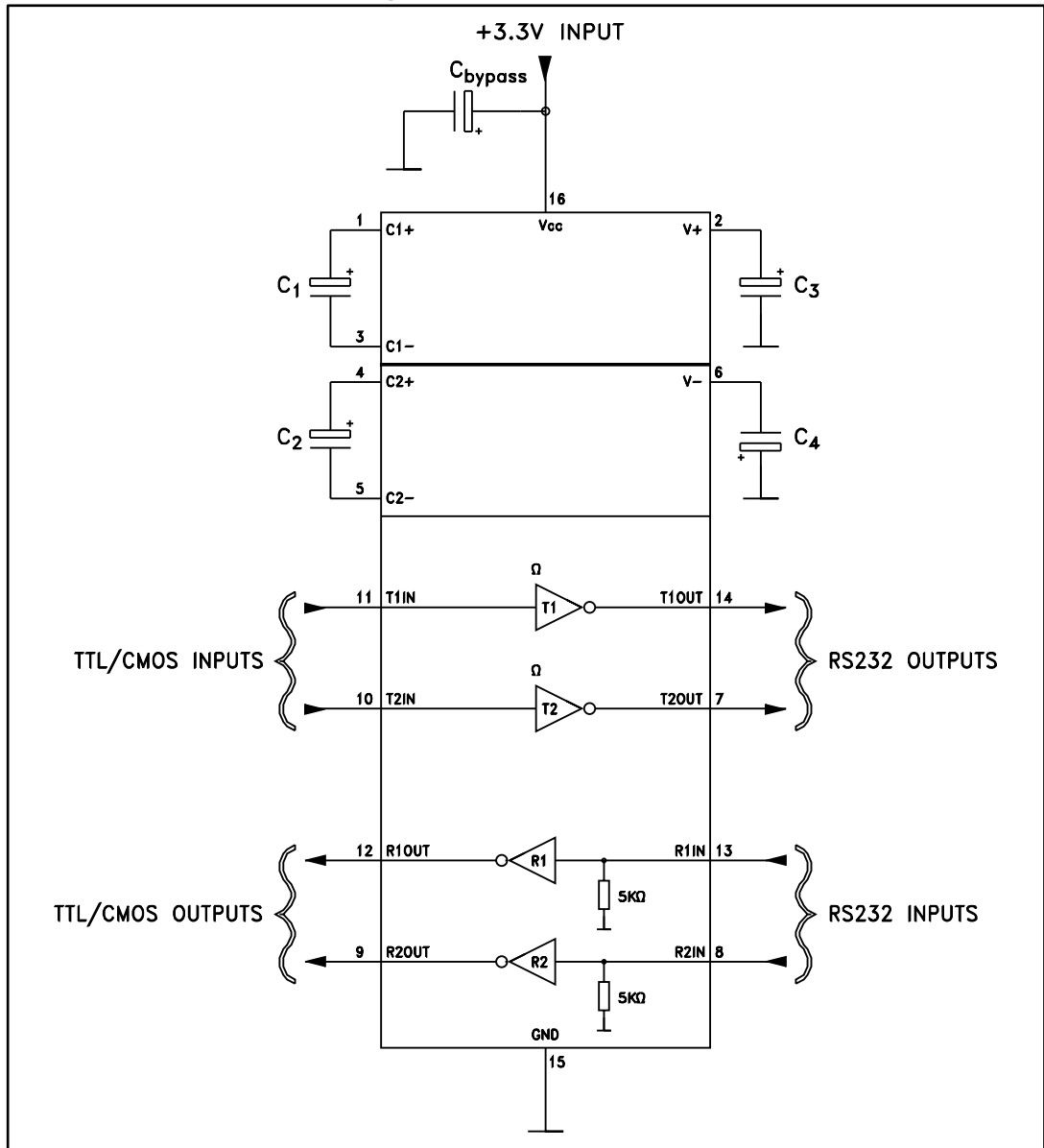

Table 9: Capacitance value (μF)

V_{CC}	C1	C2	C3	C4	C_{bypass}
3.0 to 3.6	0.1	0.1	0.1	0.1	0.1
4.5 to 5.5	0.047	0.33	0.33	0.33	0.33

5 Typical performance characteristics



Unless otherwise specified $T_J = 25\text{ }^\circ\text{C}$

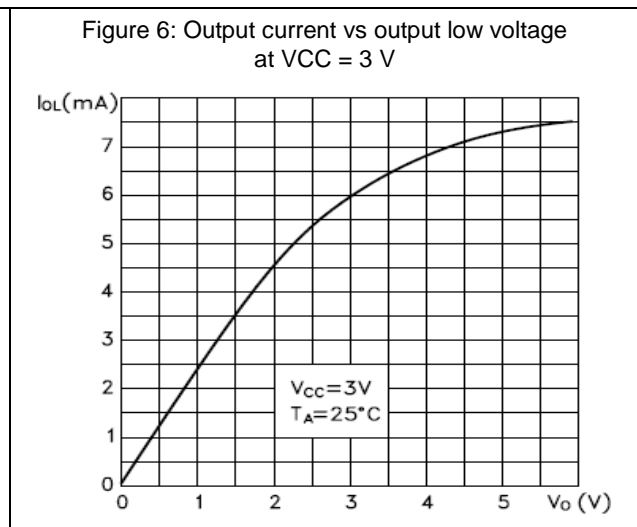
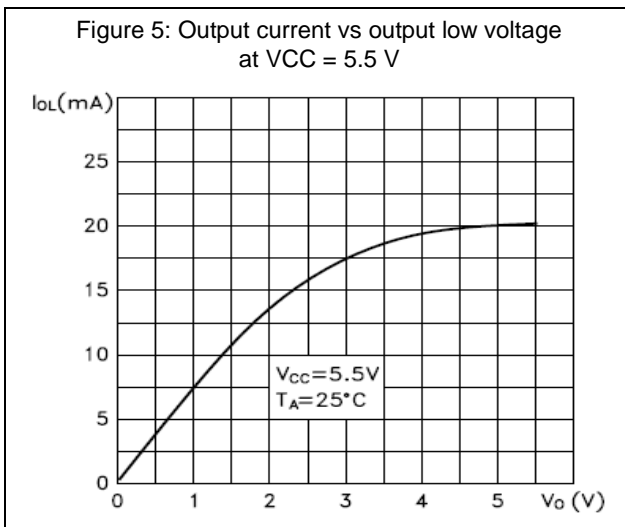
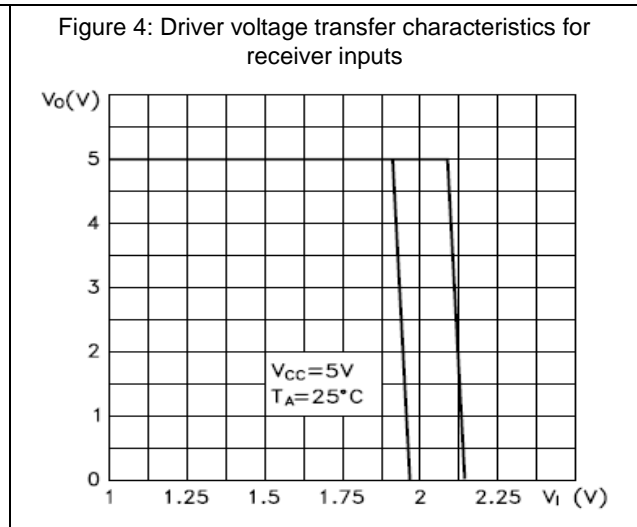
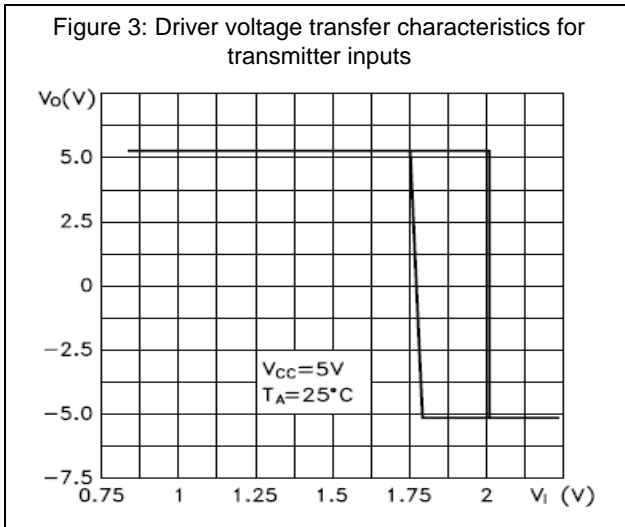

Figure 7: Output current vs output high voltage at VCC = 5.5 V

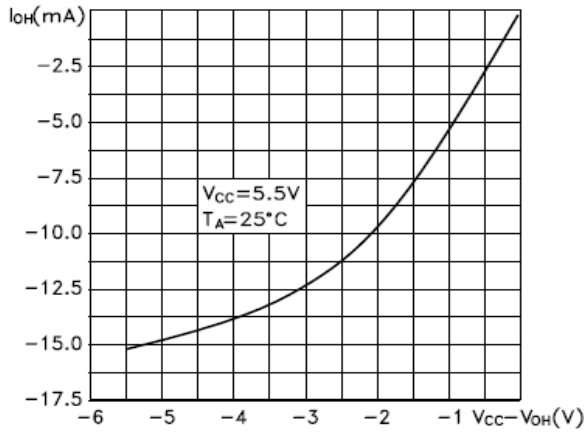

Figure 8: Output current vs output high voltage at VCC = 3 V

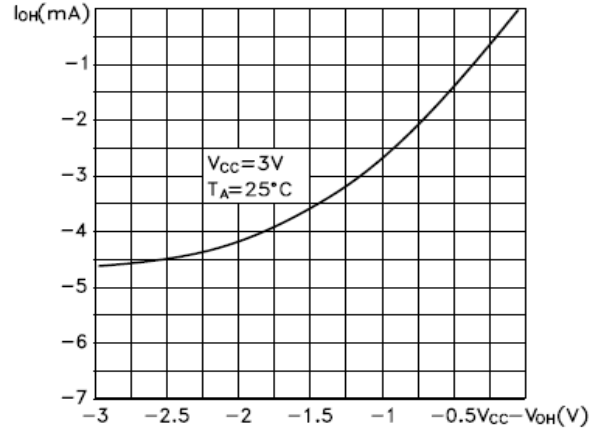
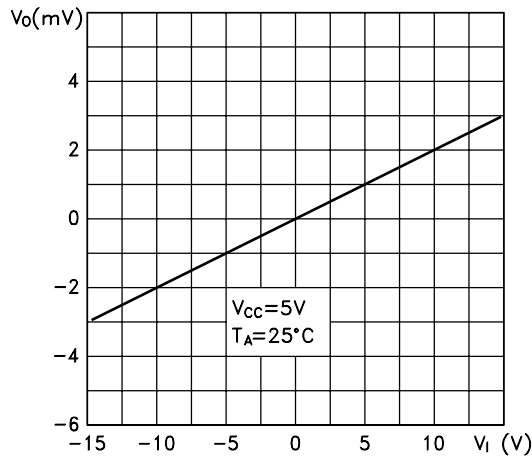

Figure 9: Receiver input resistance



6 Package information

In order to meet environmental requirements, ST offers these devices in different grades of ECOPACK[®] packages, depending on their level of environmental compliance. ECOPACK[®] specifications, grade definitions and product status are available at: www.st.com. ECOPACK[®] is an ST trademark.

6.1 SO16 package information

Figure 10: SO16 package outline

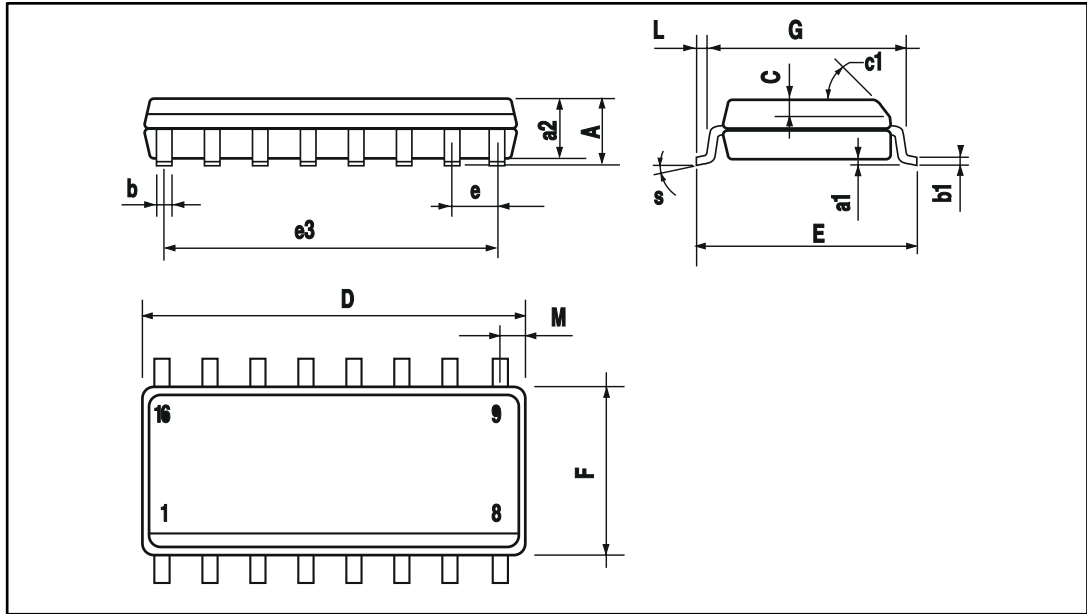

Table 10: SO16 mechanical data

Ref	Dimensions					
	Millimeters			Inches		
	Min.	Typ.	Max	Min.	Typ.	Max.
A			1.75			0.068
a1	0.1		0.25	0.004		0.010
a2			1.64			0.063
b	0.35		0.46	0.013		0.018
b1	0.19		0.25	0.007		0.010
C		0.5			0.019	
c1		45 °			45 °	
D	9.8		10	0.385		0.393
E	5.8		6.2	0.228		0.244
e		1.27			0.050	
e3		8.89			0.350	
F	3.8		4.0	0.149		0.157
G	4.6		5.3	0.181		0.208
L	0.5		1.27	0.019		0.050
M			0.62			0.024
S			8 °			8 °

6.2 SO16L package information

Figure 11: SO16L package outline

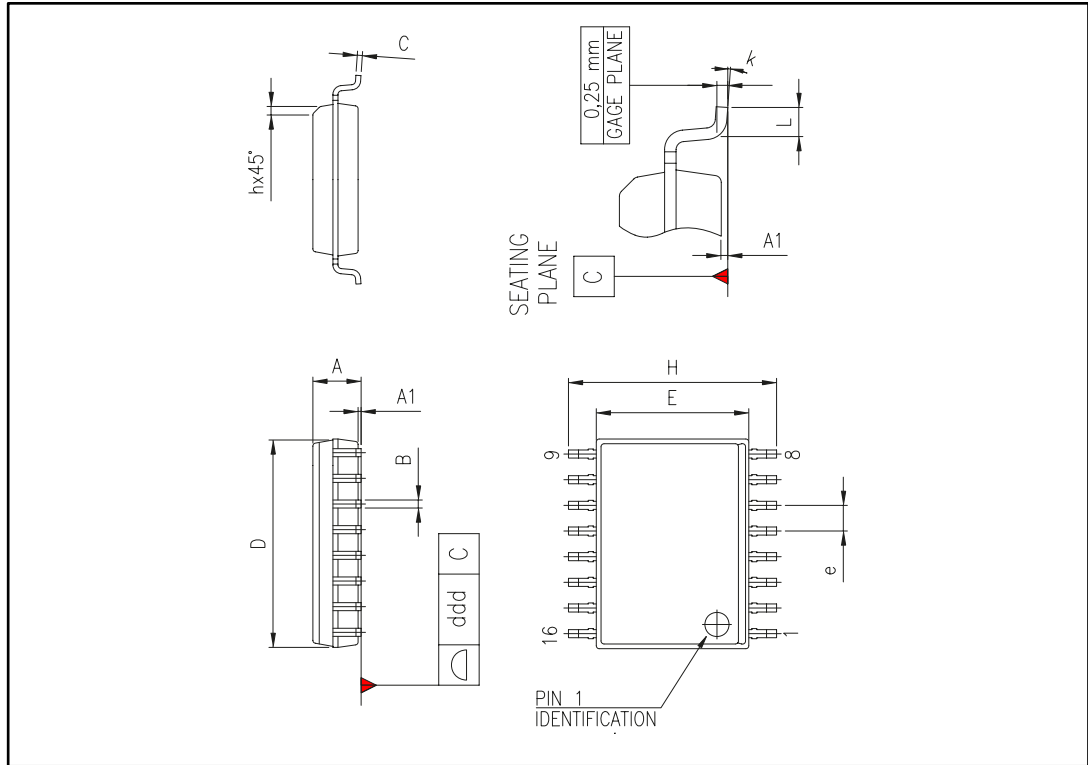

Table 11: SO16L mechanical data

Ref	Dimensions					
	Millimeters			Inches		
	Min.	Typ.	Max	Min.	Typ.	Max.
A	2.35		2.65	0.093		0.104
A1	0.1		0.3	0.004		0.012
B	0.33		0.51	0.013		0.02
C	0.23		0.32	0.009		0.013
D	10.1		10.5	0.398		0.413
E	7.4		7.6	0.291		0.299
e		1.27			0.05	
H	10		10.65	0.394		0.419
h	0.25		0.75	0.01		0.03
L	0.4		1.27	0.016		0.05
k	0 °		8 °	0 °		8 °
ddd			0.1			0.004

6.3 TSSOP16 package information

Figure 12: TSSOP16 package outline

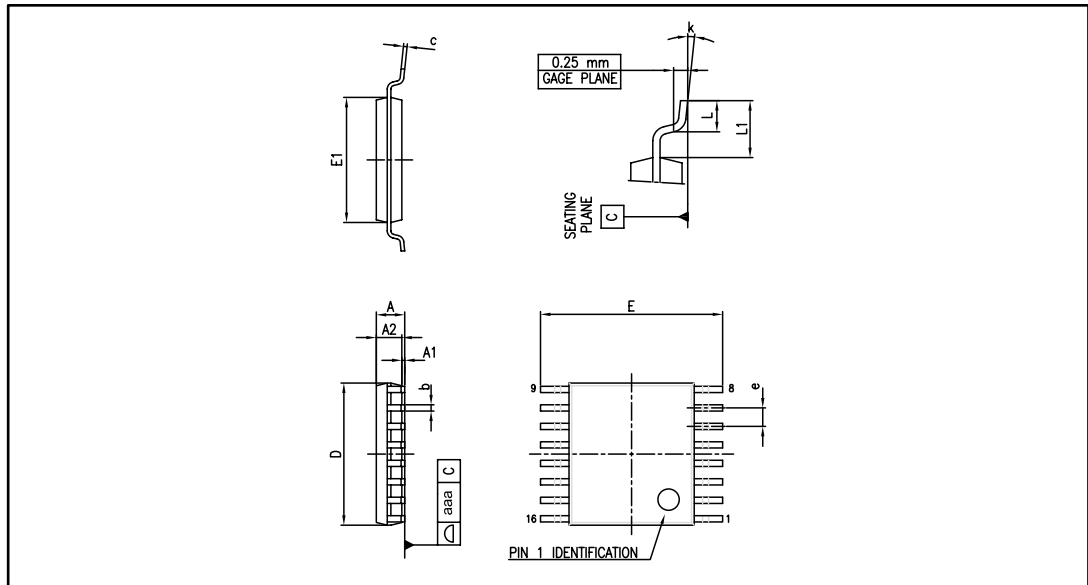
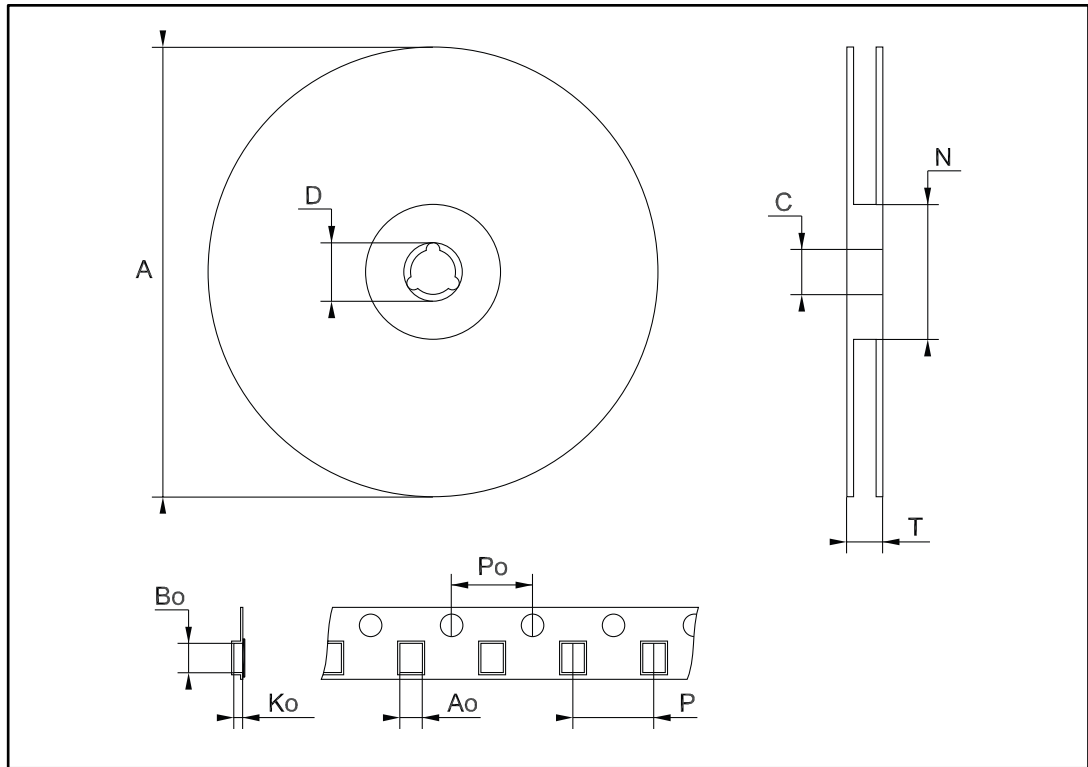

Table 12: TSSOP16 mechanical data

Ref	Dimensions					
	Millimeters			Inches		
	Min	Typ	Max	Min	Typ	Max
A			1.20			0.047
A1	0.05		0.15	0.002		0.006
A2	0.80	1.00	1.05	0.031	0.039	0.041
b	0.19		0.30	0.007		0.012
c	0.09		0.20	0.004		0.008
D	4.90	5.00	5.10	0.193	0.197	0.201
E	6.20	6.40	6.60	0.244	0.252	0.260
E1	4.30	4.40	4.50	0.169	0.173	0.177
e		0.65			0.026	
k	0°		8°	0°		8°
L	0.45	0.60	0.75	0.018	0.024	0.030
L1		1.00			0.039	
aaa			0.10			0.004

6.4 SO16 tape and reel package information

Figure 13: SO16 tape and reel package outline



1. Drawing not to scale

Table 13: SO16 tape and reel mechanical data

Ref	Dimensions					
	Millimeters			Inches		
	Min.	Typ.	Max	Min.	Typ.	Max.
A			330			12.992
C	12.8		13.2	0.504		0.519
D	20.2			0.795		
N	60			2.362		
T			22.4			0.882
Ao	6.45	—	6.65	0.254	—	0.262
Bo	10.3		10.5	0.406		0.414
Ko	2.1		2.3	0.082		0.090
Po	3.9		4.1	0.153		0.161
P	7.9		8.1	0.311		0.319

6.5 SO16L tape and reel package information

Figure 14: SO16L tape and reel package outline

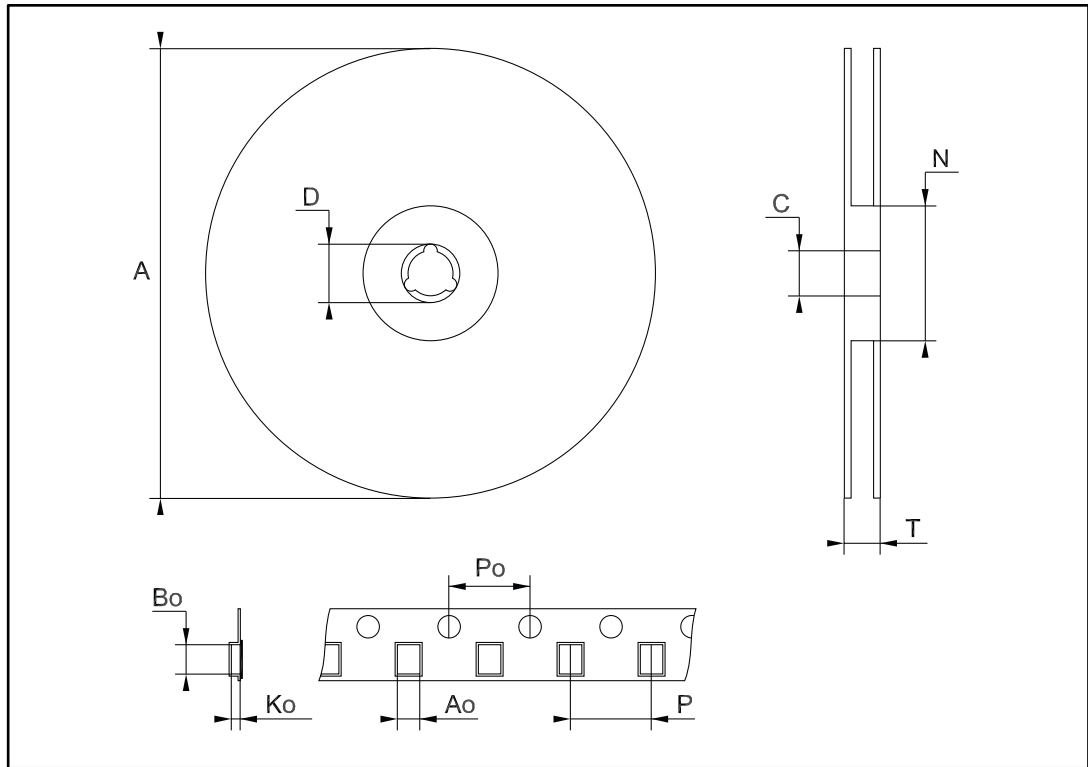

1. Drawing not to scale

Table 14: SO16L tape and reel mechanical data

Ref	Dimensions					
	Millimeters			Inches		
	Min.	Typ.	Max	Min.	Typ.	Max.
A			330			12.992
C	12.8		13.2	0.504		0.519
D	20.2			0.795		
N	60			2.362		
T			22.4			0.882
Ao	10.8	—	11.0	0.425	—	0.433
Bo	10.7		10.9	0.421		0.429
Ko	2.9		3.1	0.114		0.122
Po	3.9		4.1	0.153		0.161
P	11.9		12.1	0.468		0.476

6.6 TSSOP16 tape and reel package information

Figure 15: TSSOP16 tape and reel package outline

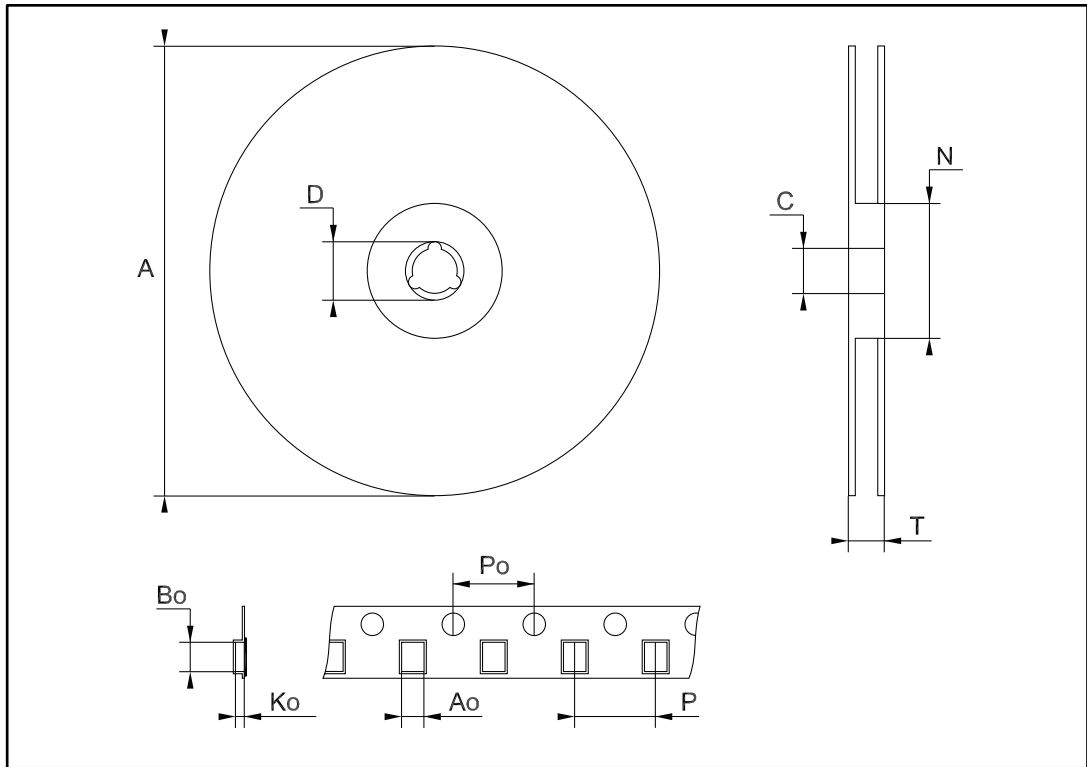

1. Drawing not to scale

Table 15: TSSOP16 tape and reel mechanical data

Ref	Dimensions					
	Millimeters			Inches		
	Min.	Typ.	Max	Min.	Typ.	Max.
A			330			12.992
C	12.8		13.2	0.504		0.519
D	20.2			0.795		
N	60			2.362		
T			22.4			0.882
Ao	6.7	—	6.9	0.264	—	0.272
Bo	5.3		5.5	0.209		0.217
Ko	1.6		1.8	0.063		0.071
Po	3.9		4.1	0.153		0.161
P	7.9		8.1	0.311		0.319

7 Revision history

Table 16: Document revision history

Date	Revision	Changes
06-Sep-2006	8	Order codes has been updated and new template.
25-Oct-2006	9	Order codes has been updated.
21-Jan-2008	10	Added note on Table 3.
08-Feb-2008	11	Modified: Table 1 on page 1.
25-Jan-2016	12	Updated document layout <i>Table 3: "Absolute maximum ratings"</i> : added T_{stg} Updated titles of <i>Figure 5</i> , <i>Figure 6</i> , <i>Figure 7</i> , and <i>Figure 8</i> <i>Section 6.2</i> : replaced SO16L package outline and mechanical data <i>Section 6.3</i> : removed A1 (typ: inches), updated E1 (max: mm and inches), added L1 and aaa.

IMPORTANT NOTICE – PLEASE READ CAREFULLY

STMicroelectronics NV and its subsidiaries ("ST") reserve the right to make changes, corrections, enhancements, modifications, and improvements to ST products and/or to this document at any time without notice. Purchasers should obtain the latest relevant information on ST products before placing orders. ST products are sold pursuant to ST's terms and conditions of sale in place at the time of order acknowledgement.

Purchasers are solely responsible for the choice, selection, and use of ST products and ST assumes no liability for application assistance or the design of Purchasers' products.

No license, express or implied, to any intellectual property right is granted by ST herein.

Resale of ST products with provisions different from the information set forth herein shall void any warranty granted by ST for such product.



ST and the ST logo are trademarks of ST. All other product or service names are the property of their respective owners.

Information in this document supersedes and replaces information previously supplied in any prior versions of this document.

© 2016 STMicroelectronics – All rights reserved

Looking for pricing, stock, or lifecycle information?

Click below to explore more details on WIN SOURCE:

-  [View ST3232BWR on WIN SOURCE](#)
-  [STMicroelectronics Information](#)

Optimize Your Supply Chain with WIN SOURCE Solutions

-  Global Sourcing Solution
-  Obsolete Management
-  Cost Control Management
-  Shortage Management
-  Alternative Solution
-  Excess Inventory Management