



THE DATASHEET OF ADP3166JRU-REEL



ADP3166—SPECIFICATIONS¹ (V_{CC} = 12 V, FBRTN = GND, T_A = 0°C to 85°C, unless otherwise noted.)

Parameter	Symbol	Conditions	Min	Typ	Max	Unit
ERROR AMPLIFIER						
Accuracy	V _{FB}	Referenced to FBRTN, CSSUM = CSCOMP, See Test Circuit 1	0.792	0.800	0.808	V
0.8 V Output						
1.175 V Output						
1.55 V Output		Referenced to FBRTN, CSSUM = CSCOMP, See Test Circuit 1	1.535	1.55	1.566	V
Line Regulation	ΔV _{FB}	V _{CC} = 10 V to 14 V		0.05		%
Input Bias Current	I _{FB}		-13	-15.5	-17	μA
FBRTN Current	I _{FBRTN}			100	200	μA
Output Current	I _{O(ERR)}	FB forced to V _{OUT} - 3%		500		μA
Gain Bandwidth Product	GBW _(ERR)	COMP = FB		20		MHz
Slew Rate		C _{COMP} = 10 pF		50		V/μs
VID INPUTS						
Input Low Voltage	V _{IL(VID)}	VID(X) = 0 V	2	20	26	0.8
Input High Voltage	V _{IH(VID)}					V
Input Current	I _{VID}					μA
Pull-Up Resistance	R _{VID}					kΩ
Internal Pull-Up Voltage			2.0	2.4	2.65	V
VID Transition Delay Time ²		VID code change to FB change	400			ns
No CPU Detection Turn-Off Delay Time ²		VID code change to 11111 to PWM going low	400			ns
OSCILLATOR						
Frequency Range ²	f _{OSC}	T _A = 25°C, R _T = 250 kΩ, 4-phase T _A = 25°C, R _T = 115 kΩ, 4-phase ² T _A = 25°C, R _T = 75 kΩ, 4-phase ²	0.25		4	MHz
Frequency Variation	f _{PHASE}		160	200	240	kHz
				400	600	kHz
Output Voltage	V _{RT}	R _T = 100 kΩ to GND	1.9	2.0	2.1	V
Timing Resistor Value					500	kΩ
RAMPADJ Voltage	V _{RAMPADJ}	RAMPADJ - FB	-50		+50	mV
RAMPADJ Input Current Range	I _{RAMPADJ}		0		50	μA
CURRENT SENSE AMPLIFIER						
Offset Voltage	V _{OS(CSA)}	CSSUM - CSREF, see Test Circuit 2	-3		+3	mV
Input Bias Current	I _{BIAS(CSA)}			20	100	nA
Gain Bandwidth Product	GBW _{CSA}			20		MHz
Slew Rate		C _{CSCOMP} = 10 pF		50		V/μs
Input Common-Mode Range		CSSUM and CSREF	0		3	V
Positioning Accuracy	ΔV _{FB}	See Test Circuit 3	-76	-80	-84	mV
Output Voltage Range		I _{CSCOMP} = ±100 μA	0.05		3.3	V
Output Current	I _{CSCOMP}			500		μA
CURRENT BALANCE CIRCUIT						
Common-Mode Range	V _{SW(X)CM}	SW(X) = 0 V	-600		+200	mV
Input Resistance	R _{SW(X)}		24	30	36	kΩ
Input Current	I _{SW(X)}		5	7	9	μA
Input Current Matching	ΔI _{SW(X)}		-5		+5	%
CURRENT LIMIT COMPARATOR						
Output Voltage	V _{ILIMIT(NM)} V _{ILIMIT(SD)}	EN > 2 V	2.9	3	3.1	V
Normal Mode		EN < 0.8 V, I _{ILIMIT} = -100 μA			400	mV
In Shutdown		EN > 2 V, R _{ILIMIT} = 250 kΩ		12		μA
Output Current, Normal Mode	I _{ILIMIT(NM)}	EN > 2 V	60			μA
Maximum Output Current						μA
Current Limit Threshold Voltage	V _{CL}	V _{CSREF} - V _{CSCOMP} , R _{ILIMIT} = 250 kΩ	105	125	145	mV
Current Limit Setting Ratio		V _{CL} /I _{ILIMIT}		10.4		mV/μA
Latch-Off Delay Threshold	V _{SET(DLY)}	In current limit	1.7	1.8	1.9	V
Latch-Off Delay Time	t _{SET(DLY)}	R _{DELAY} = 250 kΩ, C _{DELAY} = 4.7 nF		600		μs

Parameter	Symbol	Conditions	Min	Typ	Max	Unit
SOFT START Output Current, Soft Start Mode Soft Start Delay Time	$I_{\text{DELAY(SS)}}$ $t_{\text{DELAY(SS)}}$	During start-up, DELAY < 2.8 V $R_{\text{DELAY}} = 250 \text{ k}\Omega$, $C_{\text{DELAY}} = 4.7 \text{ nF}$ VID Code = 01111	15	20 350	25	μA μs
ENABLE INPUT Input Low Voltage Input High Voltage Input Current	$V_{\text{IL(EN)}}$ $V_{\text{IH(EN)}}$		2 -1		0.8 +1	V V μA
POWER GOOD COMPARATOR Undervoltage Threshold Overvoltage Threshold Output Low Voltage Off-State Leakage Current Delay Time VID Code Changing VID Code Static	$V_{\text{PWRGD(UV)}}$ $V_{\text{PWRGD(OV)}}$ $V_{\text{OL(PWRGD)}}$	Relative to nominal DAC output Relative to nominal DAC output $I_{\text{PWRGD(SINK)}} = 4 \text{ mA}$ $V_{\text{CSREF}} = V_{\text{DAC}}$	-200 200	-300 300 150	-400 400 400 50	mV mV mV μA μs ns
CROWBAR COMPARATOR Crowbar Trip Point Crowbar Reset Point Crowbar Response Time Overvoltage to PWM Low Overvoltage to CRWBR High Output Voltage Low Output Voltage High	V_{CROWBAR} t_{CROWBAR} $V_{\text{OL(CROWBAR)}}$ $V_{\text{OH(CROWBAR)}}$	$I_{\text{CROWBAR(SINK)}} = 100 \mu\text{A}$ $I_{\text{CROWBAR(SOURCE)}} = 100 \mu\text{A}$	2.0 300 4.0	2.1 400 400 100 5.0	2.2 500	V mV ns ns mV V
PWM OUTPUTS Output Voltage Low Output Voltage High	$V_{\text{OL(PWM)}}$ $V_{\text{OH(PWM)}}$	$I_{\text{PWM(SINK)}} = 400 \mu\text{A}$ $I_{\text{PWM(SOURCE)}} = 400 \mu\text{A}$	4.0	160 5.0	500	mV V
SUPPLY DC Supply Current UVLO Threshold Voltage UVLO Hysteresis	I_{CC} V_{UVLO}	VCC rising		7 6.5 0.7	10 7.3 1.1	mA V V

NOTES

¹All limits at temperature extremes are guaranteed via correlation using standard Statistical Quality Control (SQC).²Guaranteed by design, not tested in production.

Specifications subject to change without notice.

ADP3166

ABSOLUTE MAXIMUM RATINGS*

VCC	-0.3 V to +15 V
FBRTN	-0.3 V to +0.3 V
VID0 to VID4, EN, DELAY, ILIMIT, CSCOMP, RT, COMP, CROWBAR, PWM1 to PWM4	-0.3 V to +5.5 V
SW1 to SW4	-5 V to +25 V
All Other Inputs and Outputs	-0.3 V to VCC + 0.3 V
Operating Ambient Temperature Range	0°C to 85°C
Operating Junction Temperature	125°C
Storage Temperature Range	-65°C to +150°C
θ_{JA}	100°C/W

Lead Temperature (Soldering, 10 sec)	300°C
Vapor Phase (60 sec)	215°C
Infrared (15 sec)	220°C

*Stresses above those listed under Absolute Maximum Ratings may cause permanent damage to the device. This is a stress rating only. Functional operation of the device at these or any other conditions above those listed in the operational sections of this specification is not implied. Exposure to absolute maximum rating conditions for extended periods may affect device reliability. Absolute maximum ratings apply individually only, not in combination. Unless otherwise specified, all other voltages are referenced to GND.

ORDERING GUIDE

Model	Temperature Range	Package Options	Quantity per Reel
ADP3166JRU-REEL7	0°C to 85°C	RU-28 (TSSOP-28)	1000
ADP3166JRU-REEL	0°C to 85°C	RU-28 (TSSOP-28)	2500

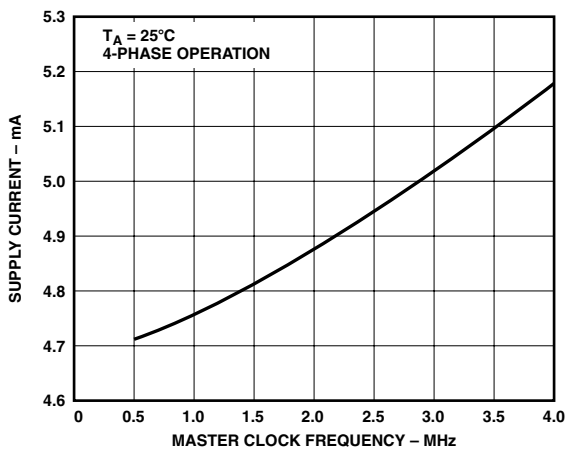

TPC 1. Supply Current vs. Master Clock Frequency

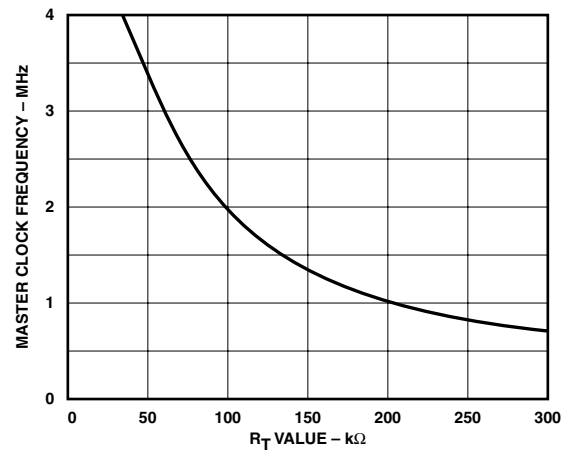

TPC 2. Master Clock Frequency vs. R_T

CAUTION

ESD (electrostatic discharge) sensitive device. Electrostatic charges as high as 4000 V readily accumulate on the human body and test equipment and can discharge without detection. Although the ADP3166 features proprietary ESD protection circuitry, permanent damage may occur on devices subjected to high energy electrostatic discharges. Therefore, proper ESD precautions are recommended to avoid performance degradation or loss of functionality.



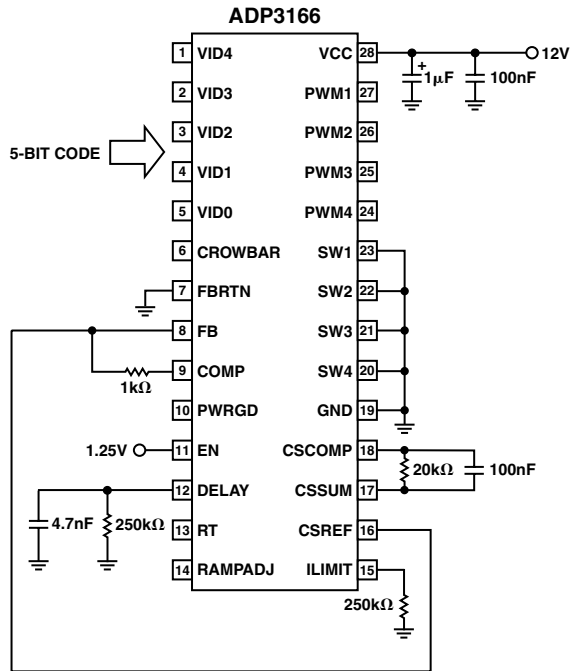

Test Circuit 1. Closed-Loop Output Voltage Accuracy

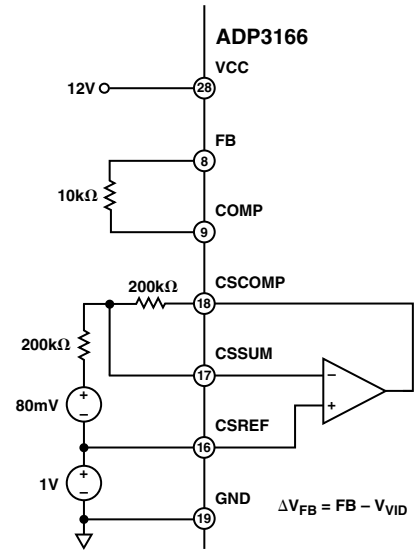

Test Circuit 3. Positioning Voltage Test Circuit

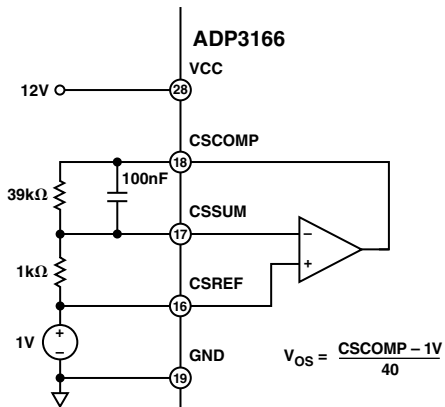

Test Circuit 2. Positioning Amplifier V_{OS} Test Circuit

ADP3166

PIN CONFIGURATION RU-28

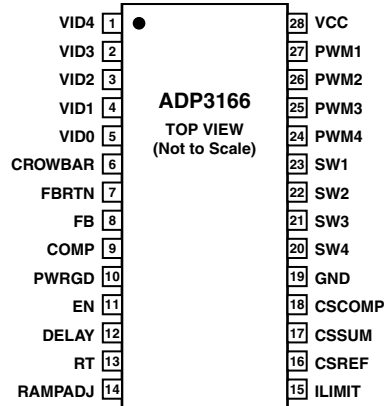

PIN FUNCTION DESCRIPTIONS

Pin No.	Mnemonic	Function
1–5	VID4–VID0	Voltage Identification DAC Inputs. These five pins are pulled up to an internal reference, providing a logic 1 if left open. When in normal operation mode, the DAC output programs the FB regulation voltage from 0.8 V to 1.55 V. Leaving VID4 through VID0 open results in the ADP3166 going into a “No CPU” mode, shutting off its PWM outputs.
6	CROWBAR	Crowbar Output. This logic-level output can be used to control an external device to short the 12 V supply to ground to protect the CPU from overvoltage if CSREF exceeds 2.1 V.
7	FBRTN	Feedback Return. VID DAC and error amplifier reference for remote sensing of the output voltage.
8	FB	Feedback Input. Error amplifier input for remote sensing of the output voltage. A resistor between this pin and the output voltage sets the no-load offset point.
9	COMP	Error Amplifier Output and Compensation Point.
10	PWRGD	Power Good Output. Open-drain output that pulls to GND when the output voltage is outside of the proper operating range.
11	EN	Power Supply Enable Input. Pulling this pin to GND disables the PWM outputs.
12	DELAY	Soft Start Delay and Current Limit Latch-Off Delay Setting Input. A resistor and capacitor connected between this pin and GND sets the soft start ramp-up time and the overcurrent latch-off delay time.
13	RT	Frequency Setting Resistor Input. An external resistor connected between this pin and GND sets the oscillator frequency of the device.
14	RAMPADJ	PWM Ramp Current Input. A resistor from the converter input voltage to this pin sets the internal PWM ramp.
15	ILIMIT	Current Limit Set Point/Enable Output. A resistor from this pin to GND sets the current limit threshold of the converter. This pin is actively pulled low when the ADP3166 EN input is low, or when VCC is below its UVLO threshold to signal to the driver IC that the driver high-side and low-side outputs should go low.
16	CSREF	Current Sense Reference Voltage Input. The voltage on this pin is used as the reference for the current sense amplifiers and the Power Good and Crowbar functions. This pin should be connected to the common point of the output inductors.
17	CSSUM	Current Sense Summing Node. Resistors from each switch node to this pin sum the average inductor currents together to measure the total output current.
18	CSCOMP	Current Sense Compensation Point. A resistor and capacitor from this pin to CSSUM determine the slope of the load line and the positioning loop response time.
19	GND	Ground. All internal biasing and the logic output signals of the device are referenced to this ground.
20–23	SW4–SW1	Current Balance Inputs. Inputs for measuring the current level in each phase. The SW pins of unused phases should be grounded.
24–27	PWM4–PWM1	Logic-Level PWM Outputs. Each output is connected to the input of an external MOSFET driver such as the ADP3413 or ADP3418. Connecting the PWM3 and/or PWM 4 outputs to GND will cause that phase to turn off, allowing the ADP3166 to operate as a 2-, 3-, or 4-phase controller.
28	VCC	Supply Voltage for the Device.

THEORY OF OPERATION

The ADP3166 combines a multimode, fixed frequency PWM control with multiphase logic outputs for use in 2-, 3-, and 4-phase synchronous buck CPU core supply power converters. The internal 5-bit VID DAC conforms to AMD's Hammer family power specifications. Multiphase operation is important for producing the high currents and low voltages demanded by today's microprocessors. Handling the high currents in a single-phase converter would place high thermal demands on the components in the system such as the inductors and MOSFETs.

The multimode control of the ADP3166 ensures a stable, high performance topology for

- Balancing currents and thermals between phases.
- High speed response at the lowest possible switching frequency and output decoupling.
- Minimizing thermal switching losses due to lower frequency operation.
- Tight load line regulation and accuracy.
- High current output from having up to 4-phase operation.
- Reduced output ripple utilizing multiphase cancellation.
- Immunity to board layout.
- Ease of use and design due to independent component selection.
- Flexibility in operation for tailoring design to low cost or high performance.

Number of Phases

The number of operational phases and their phase relationship are determined by internal circuitry that monitors the PWM outputs. Normally, the ADP3166 operates as a 4-phase PWM controller. Grounding the PWM 4 pin programs 3-phase operation, and grounding the PWM3 and PWM4 pins programs 2-phase operation.

When the ADP3166 is enabled, the controller outputs a voltage on PWM3 and PWM4 that is approximately 550 mV. An internal comparator checks each pin's voltage versus a threshold of 400 mV. If the pin is grounded, it will be below the threshold and the phase will be disabled. The output impedance of the PWM pin is approximately 5 k Ω . Any external pull-down resistance connected to the PWM pin should not be less than 25 k Ω to ensure proper operation. The phase detection is made during the first two clock cycles of the internal oscillator. After this time, if the PWM output was not grounded, it will switch between 0 V and 5 V. If the PWM output was grounded, it will remain off.

The PWM outputs are logic-level devices intended for driving external gate drivers such as the ADP3418. Since each phase is monitored independently, operation approaching 100% duty cycle is possible. Also, more than one output can be on at a time for overlapping phases.

Master Clock Frequency

The clock frequency of the ADP3166 is set with an external resistor connected from the RT pin to ground. The frequency follows the graph in TPC 1. To determine the frequency per phase, the clock is divided by the number of phases in use. If PWM4 is grounded, divide the master clock by 3 for the frequency of the remaining phases. If PWM3 and PWM4 are grounded, divide by 2. If all phases are in use, divide by 4.

Table I. VID Code vs. Output Voltage

VID4	VID3	VID2	VID1	VID0	V _{OUT(NOM)} (V)
1	1	1	1	1	No CPU
1	1	1	1	0	0.800
1	1	1	0	1	0.825
1	1	1	0	0	0.850
1	1	0	1	1	0.875
1	1	0	1	0	0.900
1	1	0	0	1	0.925
1	1	0	0	0	0.950
1	0	1	1	1	0.975
1	0	1	1	0	1.000
1	0	1	0	1	1.025
1	0	1	0	0	1.050
1	0	0	1	1	1.075
1	0	0	1	0	1.100
1	0	0	0	1	1.125
1	0	0	0	0	1.150
0	1	1	1	1	1.175
0	1	1	1	0	1.200
0	1	1	0	1	1.225
0	1	1	0	0	1.250
0	1	0	1	1	1.275
0	1	0	1	0	1.300
0	1	0	0	1	1.325
0	1	0	0	0	1.350
0	0	1	1	1	1.375
0	0	1	1	0	1.400
0	0	1	0	1	1.425
0	0	1	0	0	1.450
0	0	0	1	1	1.475
0	0	0	1	0	1.500
0	0	0	0	1	1.525
0	0	0	0	0	1.550

Output Voltage Differential Sensing

The ADP3166 combines differential sensing with a high accuracy VID DAC and reference and a low offset error amplifier to maintain a worst-case specification of $\pm 1\%$ differential sensing error over its full operating output voltage and temperature range. The output voltage is sensed between the FB and FBRTN pins. FB should be connected through a resistor to the regulation point, usually the remote sense pin of the microprocessor. FBRTN should be connected directly to the remote sense ground point. The internal VID DAC and precision reference are referenced to FBRTN, which has a minimal current of 100 μ A to allow accurate remote sensing. The internal error amplifier compares the output of the DAC to the FB pin to regulate the output voltage.

Output Current Sensing

The ADP3166 provides a dedicated current sense amplifier (CSA) to monitor the total output current for proper voltage positioning versus load current, and for current limit detection. Sensing the load current at the output gives the total average current being delivered to the load, which is an inherently more accurate method than peak current detection or sampling the current across a sense element such as the low-side MOSFET.

ADP3166

This amplifier can be configured several ways depending on the objectives of the system:

- Output inductor ESR sensing without thermistor for lowest cost
- Output inductor ESR sensing with thermistor for improved accuracy with tracking of inductor temperature
- Sense resistors for highest accuracy measurements

The positive input of the CSA is connected to the CSREF pin, which is connected to the output voltage. The inputs to the amplifier are summed together through resistors from the sensing element (such as the switch node side of the output inductors) to the inverting input, CSSUM. The feedback resistor between CSCOMP and CSSUM sets the gain of the amplifier, and a filter capacitor is placed in parallel with this resistor. The gain of the amplifier is programmable by adjusting the feedback resistor to set the load line required by the microprocessor. The current information is then given as the difference of CSREF – CSCOMP. This difference signal is used internally to offset the VID DAC for voltage positioning, and as a differential input for the current limit comparator.

To provide the best accuracy for the sensing of current, the CSA has been designed to have a low offset input voltage. Also, the sensing gain is determined by external resistors so that it can be made extremely accurate.

Active Impedance Control Mode

For controlling the dynamic output voltage droop as a function of output current, a signal proportional to the total output current at the CSCOMP pin can be scaled to be equal to the droop impedance of the regulator times the output current. This droop voltage is then used to set the input control voltage to the system. The droop voltage is subtracted from the DAC reference input voltage directly to tell the error amplifier where the output voltage should be. This differs from previous implementations and allows enhanced feed-forward response.

Voltage Control Mode

A high gain-bandwidth voltage mode error amplifier is used for the voltage mode control loop. The control input voltage to the positive input is set via the VID 5-bit logic code according to the voltages listed in Table I. This voltage is also offset by the droop voltage for active positioning of the output voltage as a function of current, commonly known as active voltage positioning. The output of the amplifier is the COMP pin, which sets the termination voltage for the internal PWM ramps.

The negative input (FB) is tied to the output sense location with a resistor, R_B , and is used for sensing and controlling the output voltage at this point. A current source from the FB pin flowing through R_B is used for setting the no-load offset voltage from the VID voltage. The no-load voltage will be positive with respect to the VID DAC. The main loop compensation is incorporated in the feedback network between FB and COMP.

Soft Start

The power-on ramp-up time of the output voltage is set with a capacitor and resistor in parallel from the DELAY pin to ground. The RC time constant also determines the current limit latch-off time, as explained in the following section. In UVLO or when

EN is a logic low, the DELAY pin is held at ground. After the UVLO threshold is reached and EN is a logic high, the DELAY capacitor is charged up with an internal 20 μ A current source. The output voltage follows the ramping voltage on the DELAY pin, limiting the inrush current. The soft start time depends on the value of VID DAC and C_{DLY} , with a secondary effect from R_{DLY} . Refer to the Applications section for detailed information on setting C_{DLY} .

When the PWRGD threshold is reached, the soft start cycle is stopped and the DELAY pin is pulled up to 3 V. This ensures that the output voltage is at the VID voltage when the PWRGD signals to the system that the output voltage is good. If EN is taken low or if VCC drops below UVLO, the DELAY capacitor is reset to ground to be ready for another soft start cycle.

Current Limit and Short-Circuit Protection

The ADP3166 compares a programmable current limit set point to the voltage on the output of the current sense amplifier at the CSCOMP pin. The level of current limit is set with the resistor from the ILIMIT pin to ground. During normal operation, the voltage on ILIMIT is 3 V. The current through the external resistor is internally scaled to give a current limit threshold of 10.4 mV/ μ A. If the difference in voltage between CSREF and CSCOMP drops below the current limit threshold, the internal current limit amplifier will control the internal COMP voltage to maintain the average output current at the limit.

After the limit is reached, the 3 V pull-up on the DELAY pin is disconnected, and the external delay capacitor is discharged through the external resistor. A comparator monitors the DELAY voltage and shuts off the controller when the voltage drops below 1.8 V. The current limit latch-off delay time is therefore set by the RC time constant discharging from 3 V to 1.8 V. The Applications section discusses the selection of R_{DLY} based on the C_{DLY} that has been chosen.

Because the controller continues to cycle the phases during the latch-off delay time, if the short is removed before the 1.8 V threshold is reached, the controller will return to normal operation. The recovery characteristic depends on the state of PWRGD. If the output voltage is within the PWRGD window, the controller resumes normal operation. However, if short circuit has caused the output voltage to drop below the PWRGD threshold, then a soft start cycle is initiated.

The latch-off function can be reset by either removing and reapplying VCC to the ADP3166, or by pulling the EN pin low for a short time. To disable the short-circuit latch-off function, the external resistor to ground should be left open, and a large (greater than 1 M Ω) resistor should be connected from VCC to DELAY. This prevents the DELAY capacitor from discharging so the 1.8 V threshold is never reached. The resistor will have an impact on the soft start time because the current through it will add to the internal 20 μ A current source.

During startup when the output voltage is below 200 mV, a secondary current limit is active. This is necessary because the voltage swing of CSCOMP cannot go below ground. This secondary current limit controls the internal COMP voltage to the PWM comparators to 2 V. This will limit the voltage drop across the low-side MOSFETs through the current balance circuitry.

Dynamic VID

The ADP3166 incorporates the ability to dynamically change the VID input while the controller is running. This allows the output voltage to change while the supply is running and supplying current to the load. This is commonly referred to as VID on-the-fly (OTF). A VID-OTF can occur under either light load or heavy load conditions. The processor signals the controller by changing the VID inputs in multiple steps from the start code to the finish code. This change can be either positive or negative.

When a VID input changes state, the ADP3166 detects the change and blanks the DAC for a minimum of 400 ns. This time is to prevent a false code due to logic skew while the six VID inputs are changing. Additionally, the first VID change initiates the PWRGD blanking function for a minimum of 100 μ s to prevent a false PWRGD event. Each VID change will reset the internal timer.

Power Good Monitoring

The power good comparator monitors the output voltage via the CSREF pin. The PWRGD pin is an open-drain output whose high level (when connected to a pull-up resistor) indicates that the output voltage is within the nominal limits specified previously, based on the VID voltage setting. PWRGD will go low if the output voltage is outside of this specified range. PWRGD is blanked during a VID-OTF event for a period of 100 μ s to prevent false signals during the time the output is changing.

Output Crowbar

As part of the protection for the load and output components of the supply, the PWM outputs are driven low (turning on the low-side MOSFETs) and the CROWBAR logic output goes high when the output voltage exceeds the upper power good threshold. This crowbar action releases once the output voltage has fallen back within specifications if no other faults are present. The release threshold is approximately 400 mV.

Turning on the low-side MOSFETs pulls down the output as the reverse current builds up in the inductors. If the output overvoltage is due to a short of the high-side MOSFET, this action current limits the input supply or blow its fuse, protecting the microprocessor from destruction.

The CROWBAR output can be used to signal an external input crowbar or other protection circuit.

Output Enable and UVLO

The input VCC must be higher than the UVLO threshold and the EN pin must be higher than its logic threshold for the ADP3166 to begin switching. If UVLO is less than the threshold or the EN pin is a logic low, the ADP3166 is disabled. This holds the PWM outputs at ground, shorts the DELAY capacitor to ground, and holds the ILIMIT pin at ground.

In the application circuit, the ILIMIT pin should be connected to the $\overline{\text{OD}}$ pins of the ADP3418 drivers. Because ILIMIT is grounded, this disables the drivers such that both DRVH and DRVL are grounded. This feature is important to prevent discharging of the output capacitors when the controller is shut off. If the driver outputs were not disabled, a negative voltage could be generated on the output due to the high current discharge of the output capacitors through the inductors.

APPLICATION INFORMATION

The design parameters for a typical AMD K8 compliant CPU application are as follows:

- Input voltage (V_{IN}) = 12 V
- VID setting voltage (V_{VID}) = 1.500 V
- Duty cycle (D) = 0.125
- Maximum static output voltage error ($\pm V_{\text{SERR}}$) = ± 50 mV
- Maximum dynamic output voltage error ($\pm V_{\text{DERR}}$) = ± 70 mV
- Error voltage allowed for controller and ripple ($\pm V_{\text{RERR}}$) = ± 20 mV
- Maximum output current (I_{O}) = 56 A
- Maximum output current step (ΔI_{O}) = 24 A
- Static output droop resistance (R_{O}) based on:

a) No load output voltage set at upper output voltage limit.

$$V_{\text{ONL}} = V_{\text{VID}} + V_{\text{SERR}} - V_{\text{RERR}} = 1.530 \text{ V}$$

b) Full load output voltage set at lower output voltage limit.

- $V_{\text{OFL}} = V_{\text{VID}} - V_{\text{SERR}} + V_{\text{RERR}} = 1.470 \text{ V}$
- $R_{\text{O}} = (V_{\text{ONL}} - V_{\text{OFL}}) / (I_{\text{O}}) = (1.530 \text{ V} - 1.470 \text{ V}) / (56 \text{ A}) = 1.1 \text{ m}\Omega$

- Dynamic output droop resistance (R_{OD}) based on:

a) Output current step to no load with output voltage set at upper output dynamic voltage limit.

$$V_{\text{ONLD}} = V_{\text{VID}} + V_{\text{DERR}} - V_{\text{RERR}} = 1.550 \text{ V}$$

b) Output voltage prior to load change (at $I_{\text{OUT}} = \Delta I_{\text{O}}$).

- $V_{\text{OL}} = V_{\text{ONLD}} - (\Delta I_{\text{O}} \times R_{\text{O}}) = 1.504 \text{ V}$
- $R_{\text{OD}} = (V_{\text{ONLD}} - V_{\text{OL}}) / (\Delta I_{\text{O}}) = (1.550 \text{ V} - 1.504 \text{ V}) / (24 \text{ A}) = 1.9 \text{ m}\Omega$
- Number of phases (n) = 3
- Switching frequency per phase (f_{SW}) = 330 kHz

Setting the Clock Frequency

The ADP3166 uses a fixed-frequency control architecture. The frequency is set by an external timing resistor (R_{T}). The clock frequency and the number of phases determine the switching frequency per phase, which relates directly to switching losses and the sizes of the inductors and input and output capacitors. With n = 3 for three phases, a clock frequency of 990 kHz sets the switching frequency of each phase, f_{SW} , to 330 kHz, which represents a practical trade-off between the switching losses and the sizes of the output filter components. Figure 1 shows that to achieve a 990 kHz oscillator frequency, the correct value for R_{T} is 200 k Ω . Alternatively, the value for R_{T} can be calculated using

$$R_{\text{T}} = \frac{1}{(n \times f_{\text{SW}} \times 5.83 \text{ pF}) - \frac{1}{1.5 \text{ M}\Omega}} \quad (1)$$

where 5.83 pF and 1.5 M Ω are internal IC component values.

For good initial accuracy and frequency stability, it is recommended to use a 1% resistor.

ADP3166

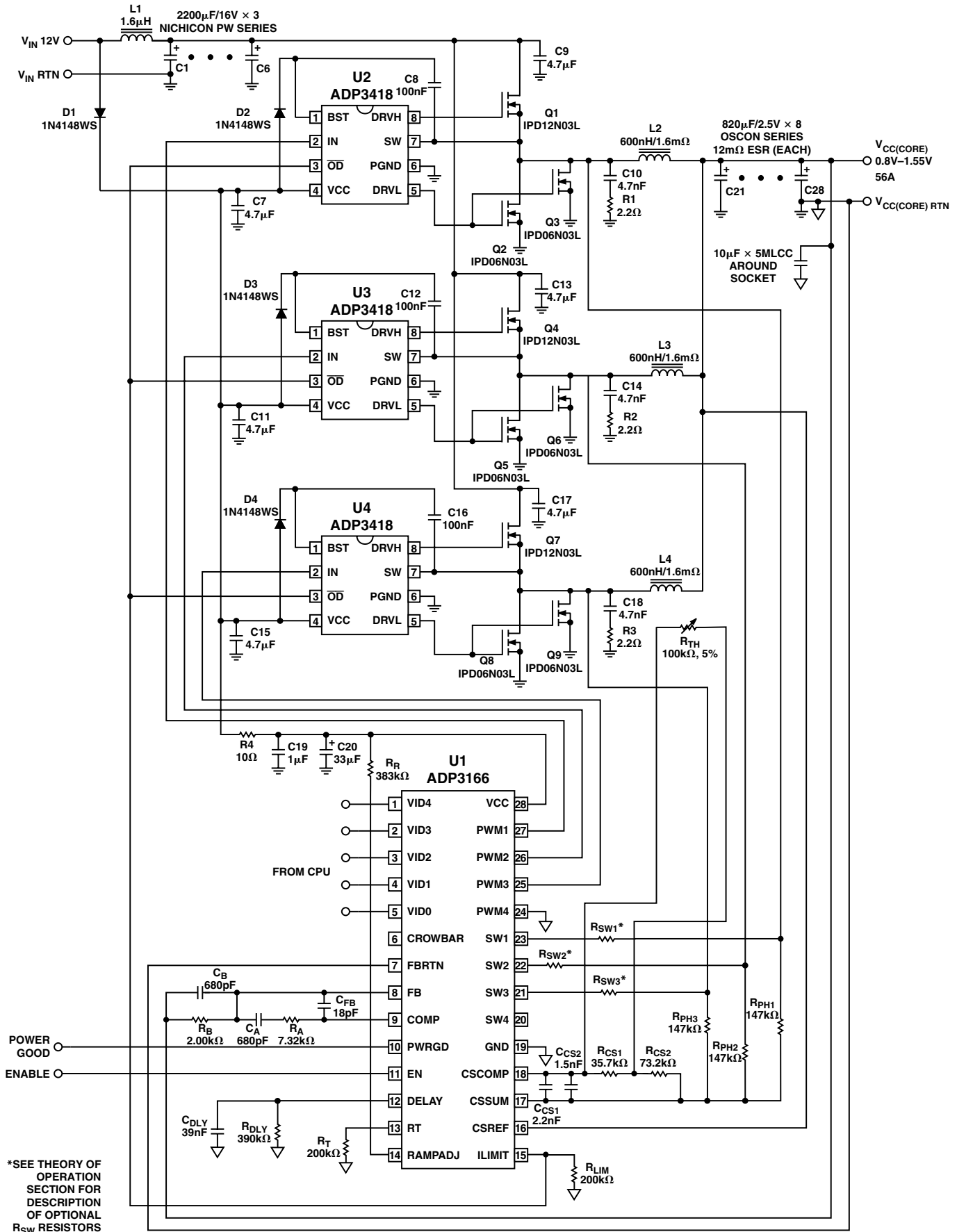

*SEE THEORY OF OPERATION SECTION FOR DESCRIPTION OF OPTIONAL R_{SW} RESISTORS

Figure 1. 56 AMD K8 CPU Supply Circuit

Soft Start and Current Limit Latch-Off Delay Times

Because the soft start and current limit latch-off delay functions share the DELAY pin, these two parameters must be considered together. The first step is to set C_{DLY} for the soft start ramp. This ramp is generated with a 20 μA internal current source. The value of R_{DLY} will have a second order impact on the soft-start time because it sinks part of the current source to ground. However, as long as R_{DLY} is kept greater than 200 k Ω , this effect is minor. The value for C_{DLY} can be approximated using

$$C_{DLY} = \left(20\mu\text{A} - \frac{V_{VID}}{2 \times R_{DLY}} \right) \times \frac{t_{SS}}{V_{VID}} \quad (2)$$

where t_{SS} is the desired soft start time. Assuming an R_{DLY} of 390 k Ω and a desired a soft start time of 3 ms, C_{DLY} is 36 nF.

The closest standard value for C_{CS} is 39 nF. Once C_{DLY} has been chosen, R_{DLY} can be calculated for the current limit latch off time using

$$R_{DLY} = \frac{1.96 \times t_{DLY}}{C_{DLY}} \quad (3)$$

If the result for R_{DLY} is less than 200 k Ω , then a smaller soft start time should be considered by recalculating the equation for C_{DLY} or a longer latch-off time should be used. In no case should R_{DLY} be less than 200 k Ω . In this example, a delay time of 8 ms makes $R_{DLY} = 402$ k Ω . The closest standard 5% value is 390 k Ω .

Inductor Selection

The choice of inductance for the inductor determines the ripple current in the inductor. Less inductance leads to more ripple current, which increases the output ripple voltage and conduction losses in the MOSFETs but allows using smaller-size inductors and, for a specified peak-to-peak transient deviation, less total output capacitance. Conversely, a higher inductance means lower ripple current and reduced conduction losses, but requires larger-size inductors and more output capacitance for the same peak-to-peak transient deviation. In any multiphase converter, a practical value for the peak-to-peak inductor ripple current is less than 50% of the maximum dc current in the same inductor. Equation 4 shows the relationship between the inductance, oscillator frequency, and peak-to-peak ripple current in the inductor. Equation 5 can be used to determine the minimum inductance based on a given output ripple voltage:

$$I_R = \frac{V_{VID} \times (1 - D)}{f_{SW} \times L} \quad (4)$$

$$L \geq \frac{V_{VID} \times R_{OD} \times (1 - (n \times D))}{f_{SW} \times V_{RIPPLE}} \quad (5)$$

Solving Equation 5 for a 10 mV p-p output ripple voltage yields

$$L \geq \frac{1.5 \text{ V} \times 1.9 \text{ m}\Omega \times (1 - 0.375)}{330 \text{ kHz} \times 10 \text{ mV}} = 540 \text{ nH}$$

If the ripple voltage is less than that designed for, the inductor can be made smaller until the ripple value is met. This will allow optimal transient response and minimum output decoupling.

The smallest possible inductor should be used to minimize the number of output capacitors. A 600 nH inductor is a good choice for a starting point, and it gives a calculated ripple current of 6.6 A. The inductor should not saturate at the peak current of 22 A, and should be able to handle the sum of the power dissipation caused by the average current of 18.7 A in the winding and the core loss.

Another important factor in the inductor design is the DCR, which is used for measuring the phase currents. A large DCR will cause excessive power losses, while too small a value will lead to increased measurement error. A good rule is to have the DCR be about 1 to 1 1/2 times the static droop resistance (R_0). For our example, we are using an inductor with a DCR of 1.6 m Ω .

Designing an Inductor

Once the inductance and DCR are known, the next step is either to design an inductor or to find a standard inductor that comes as close as possible to meeting the overall design goals. It is also important to have the inductance and DCR tolerance specified to keep the accuracy of the system controlled. Using 20% for the inductance and 8% for the DCR (at room temperature) are reasonable tolerances that most manufacturers can meet.

The first decision in designing the inductor is to choose the core material. There are several possibilities for providing low core loss at high frequencies. Two examples are the powder cores (e.g., Kool-Mu[®] from Magnetics, Inc. or Micrometals) and the gapped soft ferrite cores (e.g., 3F3 or 3F4 from Philips). Low frequency powdered iron cores should be avoided due to their high core loss, especially when the inductor value is relatively low and the ripple current is high.

The best choices for a core geometry are closed-loop types, such as pot cores, PQ, U, and E cores, or toroids. A good compromise between price and performance are cores with a toroidal shape.

There are many useful references for quickly designing a power inductor, such as

- Magnetic Designer Software
Intusoft (<http://www.intusoft.com>)
- Designing Magnetic Components for High-Frequency DC-DC Converters
McLyman, Kg Magnetics
ISBN 1-883107-00-8

ADP3166

Selecting a Standard Inductor

The following companies can provide design consultation and deliver power inductors optimized for high power applications upon request.

- Coilcraft
(847) 639-6400
<http://www.coilcraft.com>
- Coiltronics
(561) 752-5000
<http://www.coiltronics.com>
- Sumida Electric Company
(510) 668-0660
<http://www.sumida.com>
- Vishay Intertechnology
(402) 563-6866
<http://www.vishay.com>

Output Droop Resistance

The design requires that the regulator output voltage measured at the CPU pins drops when the output current increases. The specified voltage drop corresponds to the static output droop resistance (R_O).

The output current is measured by summing together the voltage across each inductor and then passing the signal through a low-pass filter. This summer-filter is the CS amplifier configured with resistors $R_{PH(X)}$ (summers) and R_{CS} , and C_{CS} (filter). The output resistance of the regulator is set by the following equations, where R_L is the DCR of the output inductors:

$$R_O = \frac{R_{CS}}{R_{PH(X)}} \times R_L \quad (6)$$

$$C_{CS} = \frac{L}{R_L \times R_{CS}} \quad (7)$$

One has the flexibility of choosing either R_{CS} or $R_{PH(X)}$. It is best to select R_{CS} equal to 100 k Ω , and then solve for $R_{PH(X)}$ by rearranging Equation 6.

$$R_{PH(X)} = \frac{R_L}{R_O} \times R_{CS}$$

$$R_{PH(X)} = \frac{1.6 \text{ m}\Omega}{1.1 \text{ m}\Omega} \times 100 \text{ k}\Omega = 145.5 \text{ k}\Omega$$

Next, use Equation 7 to solve for C_{CS} :

$$C_{CS} = \frac{600 \text{ nH}}{1.6 \text{ m}\Omega \times 100 \text{ k}\Omega} = 3.75 \text{ nF}$$

It is best to have a dual location for C_{CS} in the layout so standard values can be used in parallel to get as close to the value desired. For this example, choosing C_{CS} to be a 1.5 nF and 2.2 nF in parallel is a good choice. For best accuracy, C_{CS} should be a 10% capacitor. The closest standard 1% value for $R_{PH(X)}$ is 147 k Ω .

Inductor DCR Temperature Correction

With the inductor's DCR being used as the sense element and copper wire being the source of the DCR, one needs to compensate for temperature changes of the inductor's winding. Fortunately, copper has a well known temperature coefficient (T_C) of 0.39%/°C.

If R_{CS} is designed to have an opposite and equal percentage change in resistance to that of the wire, it will cancel the temperature variation of the inductor's DCR. Due to the nonlinear nature of NTC thermistors, resistors R_{CS1} and R_{CS2} (see Figure 2) are needed to linearize the NTC and produce the desired temperature tracking.

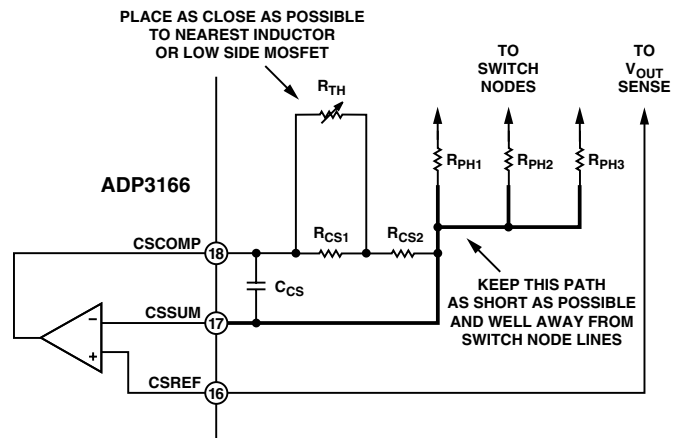

Figure 2. Temperature Compensation Circuit Values

The following procedure and expressions will yield values to use for R_{CS1} , R_{CS2} , and R_{TH} (the thermistor value at 25°C) for a given R_{CS} value.

1. Select an NTC based on type and value. Since we do not have a value yet, start with a thermistor with a value close to R_{CS} . The NTC should also have an initial tolerance of better than 5%.
2. Based on the type of NTC, find its relative resistance value at two temperatures. The temperatures to use that work well are 50°C and 90°C. We will call these resistance values A (A is $R_{TH(50^\circ\text{C})}/R_{TH(25^\circ\text{C})}$) and B (B is $R_{TH(90^\circ\text{C})}/R_{TH(25^\circ\text{C})}$). Note that the NTC's relative value is always 1 at 25°C.
3. Next, find the relative value of R_{CS} required for each of these temperatures. This is based on the percentage change needed, which we will initially make 0.39%/°C. We will call these r_1 (r_1 is $1/(1 + TC \times (T_1 - 25))$) and r_2 (r_2 is $1/(1 + TC \times (T_2 - 25))$), where $T_C = 0.0039$, $T_1 = 50^\circ\text{C}$ and $T_2 = 90^\circ\text{C}$.

4. Compute the relative values for R_{CS1} , R_{CS2} , and R_{TH} using

$$R_{CS2} = \frac{(A-B) \times r_1 \times r_2 - A \times (1-B) \times r_2 + B \times (1-A) \times r_1}{A \times (1-B) \times r_1 - B \times (1-A) \times r_2 - (A-B)}$$

$$R_{CS1} = \frac{(1-A)}{\frac{1}{1-R_{CS2}} - \frac{A}{r_1 - R_{CS2}}}$$

$$R_{TH} = \frac{1}{\frac{1}{1-R_{CS2}} - \frac{1}{R_{CS1}}}$$
(8)

5. Calculate $R_{TH} = r_{TH} \times R_{CS}$, then select the closest value of thermistor available. Also compute a scaling factor k based on the ratio of the actual thermistor value used relative to the computed one:

$$k = \frac{R_{TH(ACTUAL)}}{R_{TH(CALCULATED)}} \quad (9)$$

6. Finally, calculate values for R_{CS1} and R_{CS2} using the following:

$$R_{CS1} = R_{CS} \times k \times R_{CS1}$$

$$R_{CS2} = R_{CS} \times ((1-k) + (k \times R_{CS2})) \quad (10)$$

For this example, R_{CS} has been chosen to be 100 k Ω , so we start with a thermistor value of 100 k Ω . Looking through available 0603 size thermistors, we find a Vishay NTHS0603N01N1003JR NTC thermistor with $A = 0.3602$ and $B = 0.09174$. From these we compute $R_{CS1} = 0.3796$, $R_{CS2} = 0.7195$ and $R_{TH} = 1.0751$. Solving for R_{TH} yields 107.51 k Ω , so we choose 100 k Ω , making $k = 0.9302$. Finally, we find R_{CS1} and R_{CS2} to be 35.3 k Ω and 73.9 k Ω . Choosing the closest 1% resistor values yields a choice of 35.7 k Ω and 73.2 k Ω .

Output Offset

AMD's specification requires that at no load, the nominal output voltage of the regulator be offset to a higher value than the nominal voltage corresponding to the VID code. The offset is set by a constant current source flowing out of the FB pin (I_{FB}) and flowing through R_B . The value of R_B can be found using Equation 11:

$$R_B = \frac{V_{ONL} - V_{VID}}{I_{FB}}$$

$$R_B = \frac{1.53V - 1.5V}{15\mu A} = 2.00k\Omega \quad (11)$$

The closest standard 1% resistor value is 2.00 k Ω .

C_{OUT} Selection

The required output decoupling for the regulator is typically recommended by AMD for various processors and platforms. One can also use some simple design guidelines to determine what is required. These guidelines are based on having both bulk and ceramic capacitors in the system.

The first thing is to select the total amount of ceramic capacitance, which is based on the number and type of capacitor to be used. The best location for ceramics is inside the socket. Others can be placed along the outer edge of the socket as well.

Combined ceramic values of 30 μ F to 100 μ F are recommended, usually made up of multiple ceramic capacitors. Select the number of ceramics and find the total ceramic capacitance (C_Z).

Next, there is an upper limit imposed on the total amount of bulk capacitance (C_X) when one considers the VID on-the-fly voltage stepping of the output (voltage step V_V in time t_V with error of V_{ERR}) and a lower limit based on meeting the critical capacitance for load release for a given maximum load step ΔI_O :

$$C_{X(MIN)} \geq \left(\frac{L \times \Delta I_O}{n \times R_{OD} \times V_{VID}} - C_Z \right) \quad (12)$$

$$C_{X(MAX)} \leq \frac{L}{n \times K^2 \times R_O^2} \times \left[\frac{V_V}{V_{VID}} \left(\sqrt{1 + \left(t_V \times \frac{V_{VID}}{V_V} \times \frac{n \times K \times R_O}{L} \right)^2} - 1 \right) - C_Z \right] \quad (13)$$

where $K = \ln \left(\frac{V_{ERR}}{V_V} \right)$

To meet the conditions of these expressions and transient response, the ESR of the bulk capacitor bank (R_X) should be less than or equal to the dynamic droop resistance, R_{OD} . If the $C_{X(MIN)}$ is larger than $C_{X(MAX)}$, the system will not meet the VID on-the-fly specification and may require the use of a smaller inductor or more phases (and may have to increase the switching frequency to keep the output ripple the same).

For our example, a combination of MLCC capacitors ($C_Z = 50 \mu$ F) was used. The VID on-the-fly step change is from 1.5 V to 0.8 V (making $V_V = 700$ mV) in 100 μ s with a setting error of 3%. Solving for the bulk capacitance yields

$$C_{X(MIN)} \geq \left(\frac{600 nH \times 24 A}{3 \times 1.9 m\Omega \times 1.5 V} - 50 \mu F \right) = 1.63 mF$$

$$C_{X(MAX)} \leq \frac{600 nH \times 700 mV}{3 \times 3.5^2 \times 1.5 V} \times \left[\frac{100 ms \times 1.5 V \times 3 \times 3.5 \times 1.1 m\Omega}{700 mV \times 600 nH} - 1 \right] - 50 mF = 20.4 mF$$

where $K = 3.5$.

Using eight 820 μ F OSCONs with a typical ESR of 12 m Ω each yields $C_X = 6.56$ mF with an $R_X = 1.5$ m Ω .

One last check should be made to ensure that the ESL of the bulk capacitors (L_X) is low enough to limit the initial high frequency transient spike. This is tested using

$$L_X \geq 2 \times C_Z \times R_{OD}^2$$

$$L_X \geq 2 \times 50 mF \times 1.9 mW^2 = 361 pH \quad (14)$$

ADP3166

In this example, L_X is 375 pH for the eight OSCON capacitors, which basically satisfies this limitation. If the L_X of the chosen bulk capacitor bank is too large, the number of capacitors must be increased.

One should note for this multimode control technique, all-ceramic designs can be used as long as the conditions of Equations 12, 13, and 14 are satisfied.

Power MOSFETs

For this example, the N-channel power MOSFETs have been selected for one high-side switch and two low-side switches per phase. The main selection parameters for the power MOSFETs are $V_{GS(TH)}$, Q_G , C_{ISS} , C_{RSS} , and $R_{DS(ON)}$. The minimum gate drive voltage (the supply voltage to the ADP3418) dictates whether standard threshold or logic-level threshold MOSFETs must be used. With $V_{GATE} \sim 10$ V, logic-level threshold MOSFETs ($V_{GS(TH)} < 2.5$ V) are recommended.

The maximum output current, I_O , determines the $R_{DS(ON)}$ requirement for the low-side (synchronous) MOSFETs. With the ADP3166, currents are balanced between phases, thus the current in each low-side MOSFET is the output current divided by the total number of MOSFETs (n_{SF}). With conduction losses being dominant, the following expression shows the total power being dissipated in each synchronous MOSFET in terms of the ripple current per phase (I_R) and average total output current (I_O):

$$P_{SF} = (1 - D) \times \left[\left(\frac{I_O}{n_{SF}} \right)^2 + \frac{1}{12} \times \left(\frac{n \times I_R}{n_{SF}} \right)^2 \right] \times R_{DS(SF)} \quad (15)$$

Knowing the maximum output current being designed for and the maximum allowed power dissipation, one can find the required $R_{DS(ON)}$ for the MOSFET. For D-PAK MOSFETs up to an ambient temperature of 50°C, a safe limit for P_{SF} is 1 W to 1.5 W at 120°C junction temperature. Thus, for our example (56 A maximum), we find $R_{DS(SF)}$ (per MOSFET) < 10 mΩ. This $R_{DS(SF)}$ is also at a junction temperature of about 120°C, so we need to make sure we account for this when making this selection. For our example, we selected two lower-side MOSFETs at 7 mΩ each at room temperature, which gives 8.4 mΩ at high temperature.

Another important factor for the synchronous MOSFET is the input capacitance and the feedback capacitance. The ratio of the feedback to input needs to be small (less than 10% is recommended) to prevent accidental turn-on of the synchronous MOSFETs when the switch node goes high.

Also, the time to switch off the synchronous MOSFETs should not exceed the nonoverlap dead time of the MOSFET driver (40 ns typical for the ADP3418). The output impedance of the driver is about 2 Ω and the typical MOSFET input gate resistances are about 1 Ω to 2 Ω, so a total gate capacitance of less than 6000 pF should be adhered to. Since there are two MOSFETs in parallel, we should limit the input capacitance for each synchronous MOSFET to 3000 pF.

The high-side (main) MOSFET must be able to handle two main power dissipation components: conduction and switching losses. The switching loss is related to the amount of time it

takes for the main MOSFET to turn on and off, and to the current and voltage that are being switched. Basing the switching speed on the rise and fall time of the gate driver impedance and MOSFET input capacitance, the following expression provides an approximate value for the switching loss per main MOSFET, where n_{MF} is the total number of main MOSFETs:

$$P_{S(MF)} = 2 \times f_{SW} \times \frac{V_{CC} \times I_O}{n_{MF}} \times R_G \times \frac{n_{MF}}{n} \times C_{ISS} \quad (16)$$

Here, R_G is the total gate resistance (2 Ω for the ADP3418 and about 1 Ω for typical high speed switching MOSFETs, making $R_G = 3$ Ω) and C_{ISS} is the input capacitance of the main MOSFET. It is interesting to note that adding more main MOSFETs (n_{MF}) does not really help the switching loss per MOSFET since the additional gate capacitance slows down switching. The best thing to reduce switching loss is to use lower gate capacitance devices.

The conduction loss of the main MOSFET is given by the following, where $R_{DS(MF)}$ is the on resistance of the MOSFET:

$$P_{C(MF)} = D \times \left[\left(\frac{I_O}{n_{MF}} \right)^2 + \frac{1}{12} \times \left(\frac{n \times I_R}{n_{MF}} \right)^2 \right] \times R_{DS(MF)} \quad (17)$$

Typically, for main MOSFETs, one wants the highest speed (low C_{ISS}) device, but these usually have higher on resistance. One must select a device that meets the total power dissipation (about 1.5 W for a single D-PAK) when combining the switching and conduction losses.

For our example, we have selected an Infineon IPD12N03L as the main MOSFET (three total; $n_{MF} = 3$), with a $C_{ISS} = 1460$ pF (max) and $R_{DS(MF)} = 14$ mΩ (max at $T_J = 120^\circ\text{C}$) and an Infineon IPD06N03L as the synchronous MOSFET (six total; $n_{SF} = 6$), with $C_{ISS} = 2370$ pF (max) and $R_{DS(SF)} = 8.4$ mΩ (max at $T_J = 120^\circ\text{C}$). The synchronous MOSFET C_{ISS} is less than 3000 pF, satisfying that requirement. Solving for the power dissipation per MOSFET at $I_O = 56$ A and $I_R = 6.6$ A yields 647 mW for each synchronous MOSFET and 1.26 W for each main MOSFET. These numbers work well considering there is usually more PCB area available for each main MOSFET versus each synchronous MOSFET.

One last thing to look at is the power dissipation in the driver for each phase. This is best described in terms of the Q_G for the MOSFETs and is given by the following, where Q_{GMF} is the total gate charge for each main MOSFET and Q_{GSF} is the total gate charge for each synchronous MOSFET:

$$P_{DRV} = \left[\frac{f_{SW}}{2 \times n} \times (n_{MF} \times Q_{GMF} + n_{SF} \times Q_{GSF}) + I_{CC} \right] \times V_{CC} \quad (18)$$

Also shown is the standby dissipation factor ($I_{CC} \times V_{CC}$) for the driver. For the ADP3418, the maximum dissipation should be less than 400 mW. For our example, with $I_{CC} = 7$ mA, $Q_{GMF} = 22.8$ nC and $Q_{GSF} = 34.3$ nC, we find 265 mW in each driver, which is below the 400 mW dissipation limit. See the ADP3418 data sheet for more details.

Ramp Resistor Selection

The ramp resistor (R_R) is used for setting the size of the internal PWM ramp. The value of this resistor is chosen to provide the best combination of thermal balance, stability, and transient response. The following expression is used for determining the optimum value:

$$R_R = \frac{A_R \times L}{3 \times A_D \times R_{DS} \times C_R}$$

$$R_R = \frac{0.2 \times 600 \text{ nH}}{3 \times 5 \times 4.2 \text{ m}\Omega \times 5 \text{ pF}} = 381 \text{ k}\Omega \quad (19)$$

where A_R is the internal ramp amplifier gain, A_D is the current balancing amplifier gain, R_{DS} is the total low-side MOSFET on resistance, and C_R is the internal ramp capacitor value. The closest standard 1% resistor value is 383 k Ω .

The internal ramp voltage magnitude can be calculated using

$$V_R = \frac{A_R \times (1-D) \times V_{VID}}{R_R \times C_R \times f_{SW}}$$

$$V_R = \frac{0.2 \times (1-0.125) \times 1.5 \text{ V}}{383 \text{ k}\Omega \times 5 \text{ pF} \times 330 \text{ kHz}} = 0.41 \text{ V} \quad (20)$$

The size of the internal ramp can be made larger or smaller. If it is made larger, stability and transient response will improve, but thermal balance will degrade. Conversely, if the ramp is made smaller, thermal balance will improve at the sacrifice of transient response and stability. The factor of three in the denominator of Equation 19 sets a ramp size that gives an optimal balance for good stability, transient response, and thermal balance.

COMP Pin Ramp

There is a ramp signal on the COMP pin due to the droop voltage and output voltage ramps. This ramp amplitude adds to the internal ramp to produce the following overall ramp signal at the PWM input.

$$V_{RT} = \frac{V_R}{1 - \frac{(R_O + R_{OD}) \times (1-nD)}{n \times f_{SW} \times C_X \times R_O \times R_{OD}}} \quad (21)$$

For this example, the overall ramp signal is found to be 0.48 V.

Current Limit Set Point

To select the current limit set point, we need to find the resistor value for R_{LIM} . The current limit threshold for the ADP3166 is set with a 3 V source (V_{LIM}) across R_{LIM} with a gain of 10.4 mV/ μ A (A_{LIM}). R_{LIM} can be found using the following:

$$R_{LIM} = \frac{A_{LIM} \times V_{LIM}}{I_{LIM} \times R_O} \quad (22)$$

For values of R_{LIM} greater than 500 k Ω , the current limit may be lower than expected, so some adjustment of R_{LIM} may be needed. Here, I_{LIM} is the average current limit for the output of the supply. For our example, choosing 75 A for I_{LIM} , we find R_{LIM} to be 378 k Ω , for which we choose 374 k Ω as the nearest 1% value.

The per phase current limit described earlier has its limit determined by the following:

$$I_{PHLIM} \cong \frac{V_{COMP(MAX)} - V_R - V_{BIAS}}{A_D \times R_{DS(MAX)}} - \frac{I_R}{2} \quad (23)$$

For the ADP3166, the maximum COMP voltage ($V_{COMP(MAX)}$) is 3.3 V, the COMP pin bias voltage (V_{BIAS}) is 1.2 V, and the current balancing amplifier gain (A_D) is 5. Using V_R of 0.48 V, and $R_{DS(MAX)}$ of 4.2 m Ω (low-side on resistance at 150°C), we find a per phase limit of 74 A.

This limit can be adjusted by changing the ramp voltage V_R . But make sure not to set the per phase limit lower than the average per phase current ($I_{LIM/n}$).

There is also a per phase initial duty cycle limit determined by:

$$D_{MAX} = D \times \frac{V_{COMP(MAX)} - V_{BIAS}}{V_{RT}} \quad (24)$$

For this example, the maximum duty cycle is found to be 0.55.

Feedback Loop Compensation Design

Optimized compensation of the ADP3166 allows the best possible response of the regulator's output to a load change. The basis for determining the optimum compensation is to make the regulator and output decoupling appear as an output impedance that is optimized over the widest possible frequency range, including dc, and equal to the droop resistances (R_O and R_{OD}). With the output impedance, the output voltage will respond in proportion with the load current; this ensures the optimal output positioning and allows the minimization of the output decoupling.

With the multimode feedback structure of the ADP3166, one needs to set the feedback compensation to make the converter's output impedance work in parallel with the output decoupling to meet this goal. There are several poles and zeros created by the output inductor and decoupling capacitors (output filter) that need to be compensated for.

ADP3166

The first step is to compute the time constants for all of the poles and zeros in the system:

$$R_e = n \times R_{OD} + A_D \times R_{DS} + \frac{R_L \times V_{RT}}{V_{VID}} + \frac{(R_O + R_{OD}) \times L \times (1 - n \times D) \times V_{RT}}{n \times C_X \times R_O \times R_{OD} \times V_{VID}}$$

$$R_e = 3 \times 1.9 \text{ m}\Omega + 5 \times 4.2 \text{ m}\Omega + \frac{1.6 \text{ m}\Omega \times 0.48 \text{ V}}{1.5 \text{ V}} + \frac{(1.1 \text{ m}\Omega + 1.9 \text{ m}\Omega) \times 600 \text{ nH} \times (1 - 0.375) \times 0.48 \text{ V}}{3 \times 6.56 \text{ mF} \times 1.1 \text{ m}\Omega \times 1.9 \text{ m}\Omega \times 1.5 \text{ V}} \quad (25)$$

$$R_e = 36.0 \text{ m}\Omega$$

$$T_a = C_X \times (R_{OD} - R') + \frac{L_X}{R_{OD}} \times \frac{R_{OD} - R'}{R_X}$$

$$T_a = 6.56 \text{ mF} \times (1.9 \text{ m}\Omega - 0.6 \text{ m}\Omega) + \frac{375 \text{ pH}}{1.5 \text{ m}\Omega} \times \frac{1.9 \text{ m}\Omega - 0.6 \text{ m}\Omega}{1.5 \text{ m}\Omega}$$

$$T_a = 8.70 \text{ }\mu\text{s} \quad (26)$$

$$T_b = (R_X + R' - R_{OD}) \times C_X$$

$$T_b = (1.5 \text{ m}\Omega + 0.6 \text{ m}\Omega - 1.9 \text{ m}\Omega) \times 6.56 \text{ mF} = 1.31 \text{ }\mu\text{s} \quad (27)$$

$$T_c = \frac{V_{RT} \times \left(L - \frac{A_D \times R_{DS}}{2 \times f_{SW}} \right)}{V_{VID} \times R_e}$$

$$T_c = \frac{0.48 \text{ V} \times \left(600 \text{ nH} - \frac{5 \times 4.2 \text{ m}\Omega}{2 \times 330 \text{ kHz}} \right)}{1.5 \text{ V} \times 36.0 \text{ m}\Omega} = 5.05 \text{ }\mu\text{s} \quad (28)$$

$$T_d = \frac{C_X \times C_Z \times R_{OD}^2}{C_X \times (R_O - R) + C_Z \times R_{OD}}$$

$$T_d = \frac{6.56 \text{ mF} \times 50 \text{ mF} \times 1.9 \text{ m}\Omega^2}{6.56 \text{ mF} \times (1.9 \text{ m}\Omega - 0.6 \text{ m}\Omega) + 50 \text{ mF} \times 1.9 \text{ m}\Omega} = 137 \text{ ns} \quad (29)$$

where, for the ADP3166, R' is the PCB resistance from the bulk capacitors to the ceramics and where R_{DS} is the total low-side MOSFET on resistance per phase. For this example, A_D is 5, V_{RT} equals 0.48 V, R' is approximately 0.6 m Ω (assuming a 4-layer motherboard), and L_X is 375 pH for the eight OSCON capacitors.

A type-three compensator on the voltage feedback is adequate for proper compensation of the output filter. The expressions that follow are intended to yield an optimal starting point for the design; some adjustments may be necessary to account for PCB and component parasitic effects (see the Tuning Procedure section).

The compensation values can then be solved using the following:

$$C_A = \frac{n \times R_{OD} \times T_a}{R_e \times R_B}$$

$$C_A = \frac{3 \times 1.9 \text{ m}\Omega \times 8.70 \text{ }\mu\text{s}}{36.0 \text{ m}\Omega \times 2.00 \text{ k}\Omega} = 689 \text{ pF} \quad (30)$$

$$C_B = \frac{T_b}{R_B} = \frac{1.31 \text{ }\mu\text{s}}{2.00 \text{ k}\Omega} = 655 \text{ pF} \quad (31)$$

$$C_B = \frac{T_b}{R_B} = \frac{1.31 \text{ }\mu\text{s}}{2.00 \text{ k}\Omega} = 655 \text{ pF} \quad (32)$$

$$C_{FB} = \frac{T_d}{R_A} = \frac{137 \text{ ns}}{7.33 \text{ k}\Omega} = 18.7 \text{ pF} \quad (33)$$

Choosing the closest standard values for these components yields: $C_A = 680 \text{ pF}$, $R_A = 7.32 \text{ k}\Omega$, $C_B = 680 \text{ pF}$, and $C_{FB} = 18 \text{ pF}$.

Figure 3 shows the typical transient response using the compensation values.

C_{IN} Selection and Input Current di/dt Reduction

In continuous inductor-current mode, the source current of the high-side MOSFET is approximately a square wave with a duty ratio equal to $n \times V_{OUT}/V_{IN}$ and an amplitude one-nth of the maximum output current. To prevent large voltage transients, a low ESR input capacitor sized for the maximum rms current must be used. The maximum rms capacitor current is given by

$$I_{CRMS} = D \times I_O \times \sqrt{\frac{1}{n \times D} - 1}$$

$$I_{CRMS} = 0.125 \times 56 \text{ A} \times \sqrt{\frac{1}{3 \times 0.125} - 1} = 9.05 \text{ A} \quad (34)$$

Note that the capacitor manufacturer's ripple current ratings are often based on only 2,000 hours of life. This makes it advisable

to further derate the capacitor, or to choose a capacitor rated at a higher temperature than required. Several capacitors may be placed in parallel to meet size or height requirements in the design. In this example, the input capacitor bank is formed by three 2200 μF , 16 V Nichicon capacitors with a ripple current rating of 3.5 A each.

To reduce the input-current di/dt to below the recommended maximum of 0.1 A/ μs , an additional small inductor ($L > 1 \mu\text{H}$ @ 15 A) should be inserted between the converter and the supply bus. That inductor also acts as a filter between the converter and the primary power source.

$$R_{CS2(NEW)} = R_{CS2(OLD)} \times \frac{(V_{NL} - V_{FLCOLD})}{(V_{NL} - V_{FLHOT})} \quad (35)$$

TUNING PROCEDURE FOR ADP3166

1. Build a circuit based on compensation values computed from the design spreadsheet.
2. Hook up the dc load to the circuit, turn it on, and verify its operation. Also check for jitter at no load and full load.

DC Loadline Setting

3. Measure the output voltage at no load (V_{NL}). Verify that it is within tolerance.
4. Measure the output voltage at full load cold (V_{FLCOLD}). Let the board set for a ~10 minutes at full load and measure output (V_{FLHOT}). If there is a change of more than a few millivolts, adjust R_{CS1} and R_{CS2} using Equations 35 and 37.
5. Repeat Step 4 until the cold and hot voltage measurements remain the same.
6. Measure the output voltage from no load to full load using 5 A steps. Compute the loadline slope for each change and then average them to get the overall loadline slope (R_{OMEAS}).
7. If R_{OMEAS} is off by more than 0.05 m Ω from R_O , use Equation 36 to adjust the R_{PH} values:

$$R_{PH(NEW)} = R_{PH(OLD)} \frac{R_{OMEAS}}{R_O} \quad (36)$$

8. Repeat Steps 6 and 7 to check the loadline and repeat the adjustments if necessary.
9. Once finished with dc loadline adjustment, do not change R_{PH} , R_{CS1} , R_{CS2} , or R_{TH} for the rest of the procedure.
10. Measure the output ripple at no load and at full load with a scope and make sure that it is within spec.

$$R_{CS2(NEW)} = \frac{1}{R_{CS1(OLD)} + R_{TH(25^\circ C)} \left(\frac{1}{R_{CS1(OLD)} \times R_{TH(25^\circ C)} + (R_{CS2(OLD)} - R_{CS2(NEW)}) \times (R_{CS1(OLD)} - R_{TH(25^\circ C)}) - \frac{1}{R_{TH(25^\circ C)}} \right)} \quad (37)$$

$$C_{CS(NEW)} = C_{CS(OLD)} \frac{V_{ACDRP}}{V_{DCDRP}} \quad (38)$$

AC Loadline Setting

11. Remove the dc load from the circuit and hook up the dynamic load.
12. Hook up the scope to the output voltage and set it to dc coupling with the time scale at 100 $\mu\text{s}/\text{div}$.
13. Set the dynamic load for a transient step of about 24 A at 1 kHz with 50% duty cycle.
14. Measure the output waveform (it might be necessary to use a dc offset on scope to see the waveform). Try to use a vertical scale of 100 mV/div or finer.
15. The waveform should look something like Figure 3. Use the horizontal cursors to measure V_{ACDRP} and V_{DCDRP} as shown. **DO NOT MEASURE THE UNDERSHOOT OR OVERTHOOT THAT HAPPENS IMMEDIATELY AFTER THE STEP.**

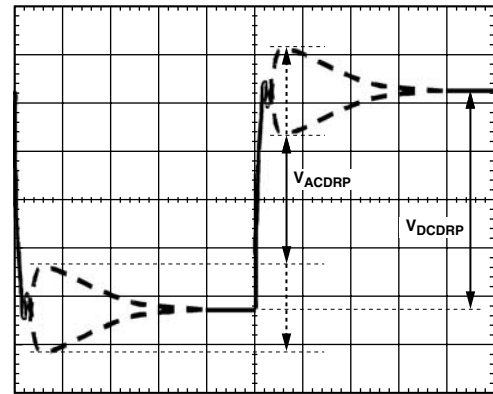

Figure 3. AC Loadline Waveform

16. If the V_{ACDRP} and V_{DCDRP} are different by more than a few millivolts, use the following to adjust C_{CS} . It might be necessary to parallel different values to get the right one since there are limited standard capacitor values available. (It is a good idea to have locations for two capacitors in the layout for this.)
17. Repeat Steps 11 to 13 and repeat adjustments if necessary. Once complete, do not change C_{CS} for the rest of the procedure.
18. Set the dynamic load step to maximum step size (do not use a step size larger than needed), and verify that the output waveform is square (meaning V_{ACDRP} and V_{DCDRP} are equal).

ADP3166

Initial Transient Setting

19. With dynamic load still set at maximum step size, expand scope time scale to see $2 \mu\text{s}/\text{div}$ to $5 \mu\text{s}/\text{div}$. The waveform may have two overshoots and one minor undershoot (see Figure 5). Here, V_{DROOP} is the final desired static value.

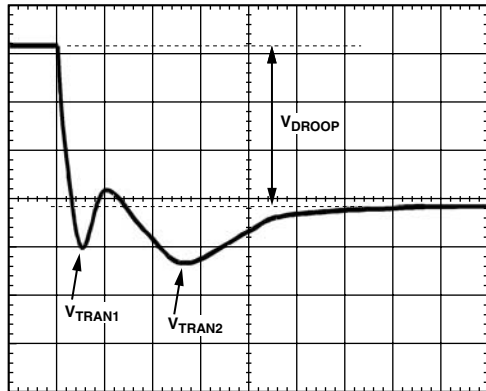

Figure 4. Transient Setting Waveform

20. If the overshoots are larger than desired, try making the following adjustments in this order (Note: if these adjustments do not change the response, you are limited by the output decoupling). Check the output response each time a change is made as well as the switching nodes (to make sure it is still stable).
- Make the ramp resistor larger by 25% (R_{RAMP}).
 - For V_{TRAN1} , increase CB or switching frequency.
 - For V_{TRAN2} , increase RA and decrease C_A by 25%.

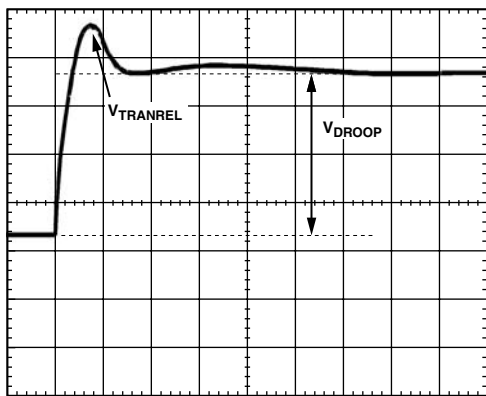

Figure 5. Transient Setting Waveform

21. For load release (see Figure 5), if V_{TRANREL} is larger than V_{TRAN1} (refer to Figure 4), there is not enough output capacitance. Either more capacitance is needed or it is necessary to make the inductor values smaller (if inductors are changed, it is necessary to start design over using the spreadsheet and this tuning guide).

LAYOUT AND COMPONENT PLACEMENT

The following guidelines are recommended for optimal performance of a switching regulator in a PC system. Key layout issues are illustrated in Figure 6.

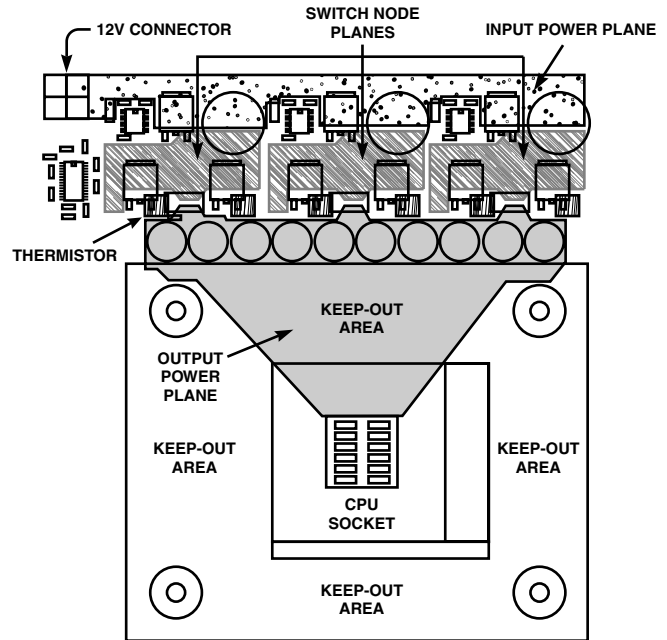

Figure 6. Layout Recommendations

General Recommendations

- For good results, at least a four-layer PCB is recommended. This should allow the needed versatility for control circuitry interconnections with optimal placement, power planes for ground, input and output power, and wide interconnection traces in the rest of the power delivery current paths. Keep in mind that each square unit of 1 ounce copper trace has a resistance of $\sim 0.53 \text{ m}\Omega$ at room temperature.
- Whenever high currents must be routed between PCB layers, vias should be used liberally to create several parallel current paths so that the resistance and inductance introduced by these current paths is minimized and the via current rating is not exceeded.
- If critical signal lines (including the output voltage sense lines of the ADP3166) must cross through power circuitry, it is best if a signal ground plane can be interposed between those signal lines and the traces of the power circuitry. This serves as a shield to minimize noise injection into the signals at the expense of making signal ground a bit noisier.
- An analog ground plane should be used around and under the ADP3166 for referencing the components associated with the controller. This plane should be tied to the nearest output decoupling capacitor ground and should not be tied to any other power circuitry to prevent power currents from flowing in it.
- The components around the ADP3166 should be located close to the controller with short traces. The most important traces to keep short and away from other traces are the FB and CSSUM pins. Refer to Figure 6 for more details on layout for the CSSUM node.
- The output capacitors should be connected as close as possible to the load (or connector) that receives the power (e.g., a microprocessor core). If the load is distributed, the capacitors should also be distributed, and generally in proportion to where the load tends to be more dynamic.
- Avoid crossing any signal lines over the switching power path loop, described below.

Power Circuitry

- The switching power path should be routed on the PCB to encompass the shortest possible length to minimize radiated switching noise energy (i.e., EMI) and conduction losses in the board. Failure to take proper precautions often results in EMI problems for the entire PC system as well as noise-related operational problems in the power converter control circuitry. The switching power path is the loop formed by the current path through the input capacitors and the power MOSFETs including all interconnecting PCB traces and planes. The use of short and wide interconnection traces is especially critical in this path for two reasons: it minimizes the inductance in the switching loop, which can cause high energy ringing, and it accommodates the high current demand with minimal voltage loss.
- Whenever a power dissipating component (e.g., a power MOSFET) is soldered to a PCB, the liberal use of vias, both directly on the mounting pad and immediately surrounding it, is recommended. Two important reasons for this are improved current rating through the vias, and improved thermal performance from vias extended to the opposite side of the PCB where a plane can more readily transfer the heat to the air. Make a mirror image of any pad being used to heatsink the MOSFETs on the opposite side of the PCB to achieve the best thermal dissipation to the air around the board. To further improve thermal performance, the largest possible pad area should be used.
- The output power path should also be routed to encompass a short distance. The output power path is formed by the current path through the inductor, the output capacitors, and the load.
- For best EMI containment, a solid power ground plane should be used as one of the inner layers extending fully under all the power components.

Signal Circuitry

- The output voltage is sensed and regulated between the FB pin and the FBRTN pin, which connects to the signal ground at the load. To avoid differential mode noise pickup in the sensed signal, the loop area should be small. Therefore the FB and FBRTN traces should be routed adjacent to each other on top of the power ground plane back to the controller.
- The feedback traces from the switch nodes should be connected as close as possible to the inductor. The CSREF signal should be connected to the output voltage at the inductor nearest to the controller.

OUTLINE DIMENSIONS

28-Lead Thin Shrink Small Outline Package [TSSOP] (RU-28)

Dimensions shown in millimeters

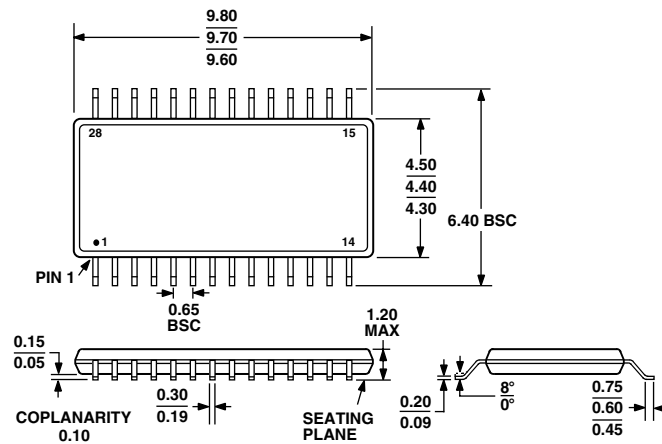

COMPLIANT TO JEDEC STANDARDS MO-153AE

Looking for pricing, stock, or lifecycle information?

Click below to explore more details on WIN SOURCE:

⊖ [View ADP3166JRU-REEL on WIN SOURCE](#)

⊖ [ON Semiconductor](#) Information

Optimize Your Supply Chain with WIN SOURCE Solutions

- ✓ Global Sourcing Solution
- ✓ Obsolete Management
- ✓ Cost Control Management
- ✓ Shortage Management
- ✓ Alternative Solution
- ✓ Excess Inventory Management