



**THE DATASHEET OF
ADP3193AJCPZ**



FEATURES

Selectable 2- or 3-phase operation at up to 1 MHz per phase
±7.7 mV worst-case differential sensing error over
temperature

Logic-level PWM outputs for interface to external high
power drivers

Fast enhanced PWM (FEPWM) flex mode for excellent load
transient performance

Active current balancing between all output phases

Built-in power-good/crowbar blanking supports on-the-fly
VID code changes

Digitally programmable 0.5 V to 1.6 V output supports both
VR10.x and VR11 specifications

Programmable short-circuit protection with programmable
latch-off delay

APPLICATIONS

Desktop PC power supplies for
Next generation Intel® processors
VRM modules

GENERAL DESCRIPTION

The ADP3193A¹ is a highly efficient, multiphase, synchronous buck switching regulator controller optimized for converting a 12 V main supply into the core supply voltage required by high performance Intel processors. It uses an internal 8-bit DAC to read a voltage identification (VID) code directly from the processor, which is used to set the output voltage between 0.5 V and 1.6 V.

This device uses a multimode PWM architecture to drive the logic-level outputs at a programmable switching frequency that can be optimized for VR size and efficiency. The phase relationship of the output signals can be programmed to provide 2- or 3-phase operation, allowing for the construction of up to three complementary buck switching stages.

The ADP3193A also includes programmable no load offset and slope functions to adjust the output voltage as a function of the load current, optimally positioning it for a system transient. The ADP3193A also provides accurate and reliable short-circuit protection, adjustable current limiting, and delayed power-good output that accommodates on-the-fly output voltage changes requested by the CPU.

FUNCTIONAL BLOCK DIAGRAM

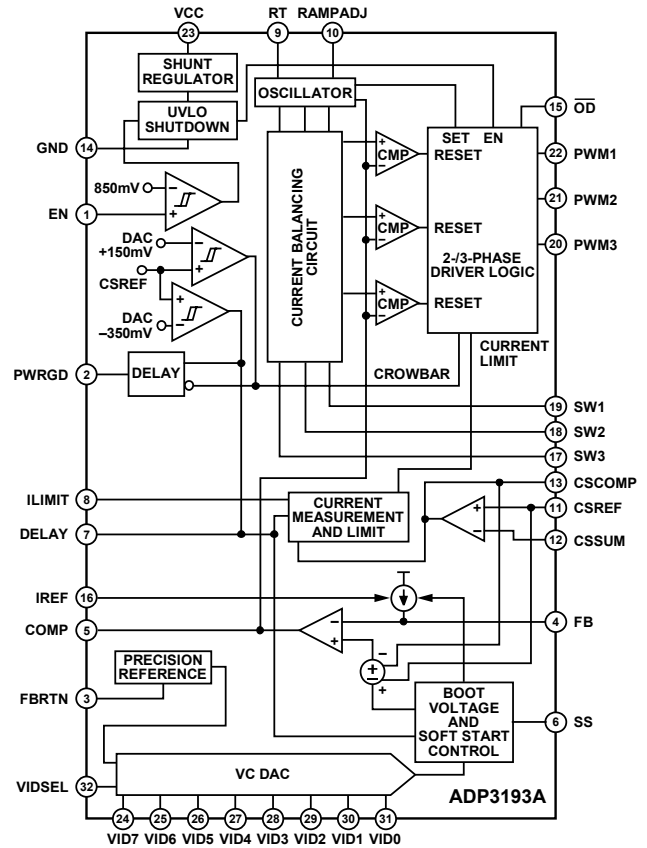

Figure 1.

The ADP3193A has a built-in shunt regulator that allows the part to be connected to the 12 V system supply through a series resistor.

The ADP3193A is specified over the extended commercial temperature range of 0°C to 85°C and is available in a 32-lead LFCSP.

¹ Protected by U.S. Patent Number 6,683,441; other patents pending.

Rev. 0

Information furnished by Analog Devices is believed to be accurate and reliable. However, no responsibility is assumed by Analog Devices for its use, nor for any infringements of patents or other rights of third parties that may result from its use. Specifications subject to change without notice. No license is granted by implication or otherwise under any patent or patent rights of Analog Devices. Trademarks and registered trademarks are the property of their respective owners.

TABLE OF CONTENTS

Features	1	Dynamic VID	12
Applications.....	1	Power-Good Monitoring.....	12
General Description.....	1	Output Crowbar	12
Functional Block Diagram	1	Output Enable and UVLO	13
Revision History	2	Application Information.....	19
Specifications.....	3	Setting the Clock Frequency.....	19
Absolute Maximum Ratings.....	5	Soft Start Delay Time.....	19
ESD Caution.....	5	Current-Limit Latch-Off Delay Times	19
Pin Configuration and Function Descriptions.....	6	Inductor Selection	19
Typical Performance Characteristics	7	Current Sense Amplifier.....	20
Test Circuits.....	8	Inductor DCR Temperature Correction	21
Theory of Operation	9	Output Offset.....	21
Start-Up Sequence.....	9	C _{OUT} Selection	22
Phase Detection Sequence.....	9	Power MOSFETs.....	23
Master Clock Frequency.....	10	Ramp Resistor Selection	24
Output Voltage Differential Sensing.....	10	COMP Pin Ramp	24
Output Current Sensing	10	Current-Limit Setpoint.....	24
Current Control Mode and Thermal Balance	10	Feedback Loop Compensation Design.....	25
Voltage Control Mode.....	10	C _{IN} Selection and Input Current di/dt Reduction.....	26
Current Reference	11	Shunt Resistor Design.....	26
Fast Enhanced PWM Mode	11	Tuning Procedure for ADP3193A.....	27
Delay Timer.....	11	Layout and Component Placement	29
Soft Start	11	Outline Dimensions	30
Current-Limit, Short-Circuit, and Latch-Off Protection.....	11	Ordering Guide	30

REVISION HISTORY

5/07—Revision 0: Initial Version

SPECIFICATIONS

VCC = 5 V, FBRTN = GND, T_A = 0°C to 85°C, unless otherwise noted.¹

Table 1.

Parameter	Symbol	Conditions	Min	Typ	Max	Unit
REFERENCE CURRENT						
Reference Bias Voltage	V _{IREF}			1.5		V
Reference Bias Current	I _{IREF}	R _{IREF} = 100 kΩ	14.25	15	15.75	μA
ERROR AMPLIFIER						
Output Voltage Range ²	V _{COMP}	Relative to nominal DAC output, referenced to FBRTN (see Figure 4)	0		4.4	V
Accuracy	V _{FB}		-7.7		+7.7	mV
	V _{FB(BOOT)}		In startup	1.092	1.1	1.108
Differential Nonlinearity			-1		+1	LSB
Input Bias Current	I _{FB}	I _{FB} = I _{IREF}	13.5	15	16.5	μA
FBRTN Current	I _{FBRTN}			65	200	μA
Output Current	I _{COMP}	FB forced to V _{OUT} - 3%		500		μA
Gain Bandwidth Product	GBW _(ERR)	COMP = FB		20		MHz
Slew Rate		COMP = FB		25		V/μs
Boot Voltage Hold Time	t _{BOOT}	C _{DELAY} = 10 nF		2		ms
VID INPUTS						
Input Low Voltage	V _{IL(VID)}	VID(x), VIDSEL			0.4	V
Input High Voltage	V _{IH(VID)}	VID(x), VIDSEL	0.8			V
Input Current	I _{IN(VID)}			-1		μA
VID Transition Delay Time ²		VID code change to FB change	400			ns
No CPU Detection Turn-Off Delay Time ²		VID code change to PWM going low	5			μs
OSCILLATOR						
Frequency Range ²	f _{OSC}		0.25		4	MHz
Frequency Variation	f _{PHASE}	T _A = 25°C, R _T = 210 kΩ, 3-phase	240	260	293	kHz
		T _A = 25°C, R _T = 100 kΩ, 3-phase		530		kHz
		T _A = 25°C, R _T = 40 kΩ, 3-phase		1000		kHz
Output Voltage	V _{RT}	R _T = 243 kΩ to GND	1.9	2.0	2.1	V
RAMPADJ Output Voltage	V _{RAMPADJ}	RAMPADJ - FB	-50		+50	mV
RAMPADJ Input Current Range	I _{RAMPADJ}		1		50	μA
CURRENT SENSE AMPLIFIER						
Offset Voltage	V _{OS(CSA)}	CSSUM - CSREF (see Figure 4)	-1.0		+1.0	mV
Input Bias Current	I _{BIAS(CSSUM)}		-10		+10	nA
Gain Bandwidth Product	GBW _(CSA)	CSSUM = CSCOMP		10		MHz
Slew Rate		C _{CSCOMP} = 10 pF		10		V/μs
Input Common-Mode Range		CSSUM and CSREF	0		3.5	V
Output Voltage Range			0.05		3.5	V
Output Current	I _{CSCOMP}			500		μA
Current Limit Latch-Off Delay Time	t _{OC(DELAY)}	C _{DELAY} = 10 nF		8		ms
CURRENT BALANCE AMPLIFIER						
Common-Mode Range	V _{SW(x)CM}		-600		+200	mV
Input Resistance	R _{SW(x)}	SW(x) = 0 V	10	17	26	kΩ
Input Current	I _{SW(x)}	SW(x) = 0 V	8	12	20	μA
Input Current Matching	ΔI _{SW(x)}	SW(x) = 0 V	-4		+4	%

ADP3193A

Parameter	Symbol	Conditions	Min	Typ	Max	Unit
CURRENT LIMIT COMPARATOR						
ILIMIT Bias Current	I _{LIMIT}	$I_{LIMIT} = 2/3 \times I_{REF}$	9	10	11	μA
ILIMIT Voltage	V _{LIMIT}	$R_{LIMIT} = 121 \text{ k}\Omega$ (V _{LIMIT} = (I _{LIMIT} × R _{LIMIT}))	1.09	1.21	1.33	V
Maximum Output Voltage			3			V
Current-Limit Threshold Voltage	V _{CL}	$V_{CSREF} - V_{CSCOMP}$, R _{LIMIT} = 121 kΩ	80	100	125	mV
Current-Limit Setting Ratio		V _{CL} /V _{LIMIT}		82.6		mV/V
DELAY TIMER						
Normal Mode Output Current	I _{DELAY}	$I_{DELAY} = I_{REF}$	12	15	18	μA
Output Current in Current Limit	I _{DELAY(CL)}	$I_{DELAY(CL)} = 0.25 \times I_{REF}$	3.0	3.75	4.5	μA
Threshold Voltage	V _{DELAY(TH)}		1.6	1.7	1.8	V
SOFT START						
Output Current	I _{SS}	During startup, I _{SS} = I _{REF}	12	15	18	μA
ENABLE INPUT						
Threshold Voltage	V _{TH(EN)}		800	850	900	mV
Hysteresis	V _{HYS(EN)}		80	100	125	mV
Input Current	I _{IN(EN)}			-1		μA
Delay Time	t _{DELAY(EN)}	EN > 950 mV, C _{DELAY} = 10 nF		2		ms
OD OUTPUT						
Output Low Voltage	V _{OL(OD)}			160	500	mV
Output High Voltage	V _{OH(OD)}		4	5		V
POWER-GOOD COMPARATOR						
Undervoltage Threshold	V _{PWRGD(UV)}	Relative to nominal DAC output	-400	-350	-300	mV
Overvoltage Threshold	V _{PWRGD(OV)}	Relative to nominal DAC output	100	150	200	mV
Output Low Voltage	V _{OL(PWRGD)}	I _{PWRGD(SINK)} = -4 mA		150	300	mV
Power-Good Delay Time						
During Soft Start ²		C _{DELAY} = 10 nF		2		ms
VID Code Changing			100	250		μs
VID Code Static				200		ns
Crowbar Trip Point	V _{CROWBAR}	Relative to nominal DAC output	100	150	200	mV
Crowbar Reset Point		Relative to FBRTN	320	375	430	mV
Crowbar Delay Time	t _{CROWBAR}	Overvoltage to PWM going low				
VID Code Changing			100	250		μs
VID Code Static				400		ns
PWM OUTPUTS						
Output Low Voltage	V _{OL(PWM)}	I _{PWM(SINK)} = -400 μA		160	500	mV
Output High Voltage	V _{OH(PWM)}	I _{PWM(SOURCE)} = 400 μA	4.0	5		V
SUPPLY						
VCC ²	VCC	V _{SYSTEM} = 12 V, R _{SHUNT} = 340 Ω (see Figure 4)	4.65	5	5.55	V
DC Supply Current	I _{VCC}	V _{SYSTEM} = 13.2 V, R _{SHUNT} = 340 Ω			25	mA
UVLO Turn-On Current				6.5	11	mA
UVLO Threshold Voltage	V _{UVLO}	VCC rising	9			V
UVLO Turn-Off Voltage		VCC falling		4.1		V

¹ All limits at temperature extremes are guaranteed via correlation using standard statistical quality control (SQC).

² Guaranteed by design or bench characterization, not tested in production.

ABSOLUTE MAXIMUM RATINGS

Table 2.

Parameter	Rating
VCC	-0.3 V to +6 V
FBRTN	-0.3 V to +0.3 V
PWM1 to PWM3, RAMPADJ	-0.3 V to VCC + 0.3 V
SW1 to SW3	-5 V to +25 V
<200 ns	-10 V to +25 V
All Other Inputs and Outputs	-0.3 V to VCC + 0.3 V
Storage Temperature Range	-65°C to +150°C
Operating Ambient Temperature Range	0°C to 85°C
Operating Junction Temperature	125°C
Thermal Impedance (θ_{JA})	32.6°C/W
Lead Temperature	
Soldering (10 sec)	300°C
Infrared (15 sec)	260°C

Stresses above those listed under Absolute Maximum Ratings may cause permanent damage to the device. This is a stress rating only; functional operation of the device at these or any other conditions above those indicated in the operational section of this specification is not implied. Exposure to absolute maximum rating conditions for extended periods may affect device reliability.

Absolute maximum ratings apply individually only, not in combination. Unless otherwise specified, all other voltages are referenced to GND.

ESD CAUTION



ESD (electrostatic discharge) sensitive device. Charged devices and circuit boards can discharge without detection. Although this product features patented or proprietary protection circuitry, damage may occur on devices subjected to high energy ESD. Therefore, proper ESD precautions should be taken to avoid performance degradation or loss of functionality.

PIN CONFIGURATION AND FUNCTION DESCRIPTIONS

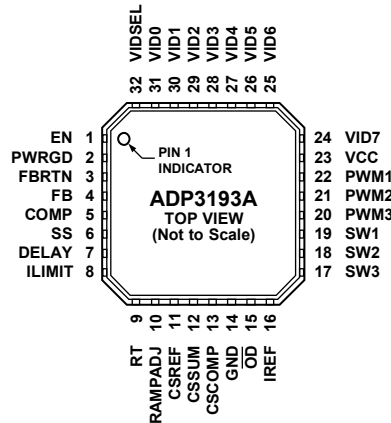

NOTES
 1. THE EXPOSED EPAD ON BOTTOM SIDE OF PACKAGE IS AN ELECTRICAL CONNECTION AND SHOULD BE SOLDERED TO GROUND.

086822-005

Figure 2. Pin Configuration

Table 3. Pin Function Descriptions

Pin No.	Mnemonic	Description
1	EN	Power Supply Enable Input. Pulling this pin to GND disables the PWM outputs and pulls the PWRGD output low.
2	PWRGD	Power-Good Output. Open-drain output that signals when the output voltage is outside of the proper operating range.
3	FBRTN	Feedback Return. VID DAC and error amplifier reference for remote sensing of the output voltage.
4	FB	Feedback Input. Error amplifier input for remote sensing of the output voltage. An external resistor between this pin and the output voltage sets the no load offset point.
5	COMP	Error Amplifier Output and Compensation Point.
6	SS	Soft Start Delay Setting Input. An external capacitor connected between this pin and GND sets the soft start ramp-up time.
7	DELAY	Delay Timer Setting Input. An external capacitor connected between this pin and GND sets the overcurrent latch-off delay time, boot voltage hold time, EN delay time, and PWRGD delay time.
8	ILIMIT	Current-Limit Set Point. An external resistor from this pin to GND sets the current-limit threshold of the converter.
9	RT	Frequency Setting Resistor Input. An external resistor connected between this pin and GND sets the oscillator frequency of the device.
10	RAMPADJ	PWM Ramp Current Input. An external resistor from the converter input voltage to this pin sets the internal PWM ramp.
11	CSREF	Current Sense Reference Voltage Input. The voltage on this pin is used as the reference for the current sense amplifier and the power-good and crowbar functions. This pin should be connected to the common point of the output inductors.
12	CSSUM	Current Sense Summing Node. External resistors from each switch node to this pin sum the average inductor currents to measure the total output current.
13	CSCOMP	Current Sense Compensation Point. A resistor and capacitor from this pin to CSSUM determines the gain of the current sense amplifier and the positioning loop response time.
14	GND	Ground. All internal biasing and the logic output signals of the device are referenced to this ground.
15	OD	Output Disable Logic Output. This pin is actively pulled low when the EN input is low or when VCC is below its UVLO threshold to signal to the driver IC that the driver high-side and low-side outputs should go low.
16	IREF	Current Reference Input. An external resistor from this pin to ground sets the reference current for I_{FB} , I_{DELAY} , I_{SS} , and I_{LIMIT} .
17 to 19	SW3 to SW1	Current Balance Inputs. Inputs for measuring the current level in each phase. The SW pins of unused phases should be left open.
20 to 22	PWM3 to PWM1	Logic-Level PWM Outputs. Each output is connected to the input of an external MOSFET driver, such as the ADP3120A. Connecting PWM3 output to VCC causes that phase to turn off, allowing the ADP3193A to operate as a 2- or 3-phase controller.
23	VCC	Supply Voltage. A 340 Ω resistor should be placed between the 12 V system supply and the VCC pin. The internal shunt regulator maintains VCC = 5 V.
24 to 31	VID7 to VID0	Voltage Identification DAC Inputs. These eight pins are pulled down to GND, providing a logic zero if left open. When in normal operation mode, the DAC output programs the FB regulation voltage from 0.5 V to 1.6 V (see Table 4).
32	VIDSEL	VID DAC Selection Pin. The logic state of this pin determines whether the internal VID DAC decodes VID0 to VID7 as extended VR10 or VR11 inputs.

TYPICAL PERFORMANCE CHARACTERISTICS

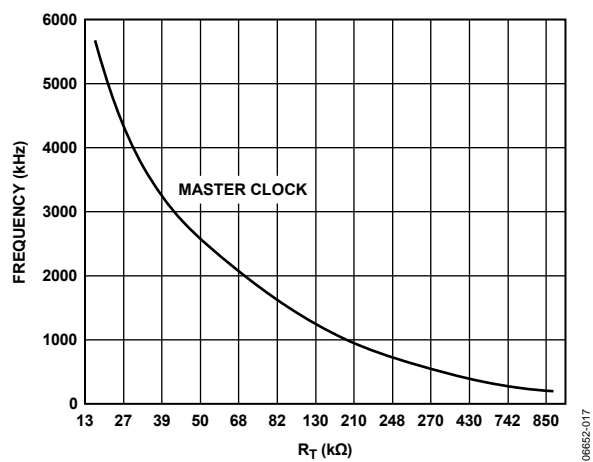

Figure 3. Master Clock Frequency vs. R_T

ADP3193A

TEST CIRCUITS

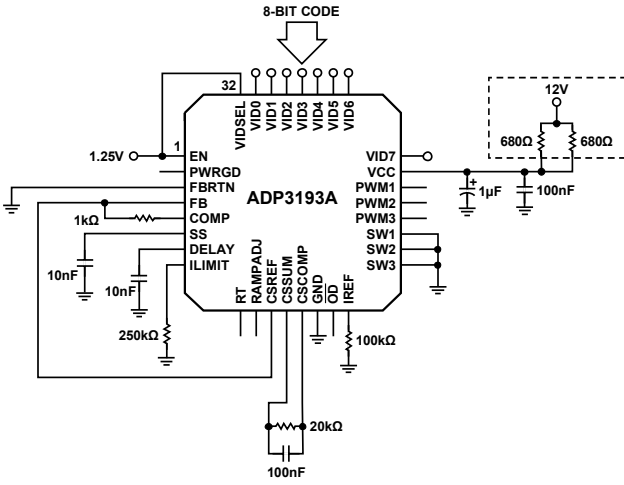

Figure 4. Closed-Loop Output Voltage Accuracy

06652-002

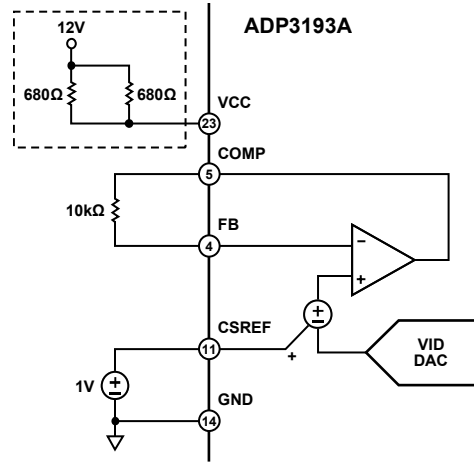

Figure 6. Positioning Voltage

06652-004

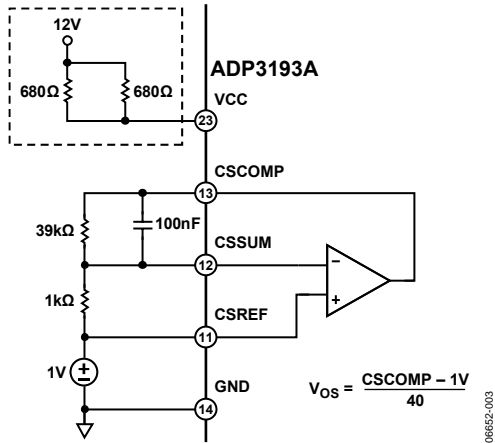

Figure 5. Current Sense Amplifier Offset Voltage (V_{OS})

$$V_{OS} = \frac{CSREF - 1V}{40}$$

06652-003

THEORY OF OPERATION

The ADP3193A combines a multimode, fixed-frequency PWM control with multiphase logic outputs for use in 2- and 3-phase synchronous buck CPU core supply power converters. The internal VID DAC is designed to interface with the Intel 8-bit VRD/VRM 11 and 7-bit VRD/VRM 10.x CPUs. Multiphase operation is important for producing the high currents and low voltages demanded by today's microprocessors. Handling the high currents in a single-phase converter increases thermal demands on the components in the system, such as the inductors and MOSFETs.

The multimode control of the ADP3193A ensures a stable, high performance topology for the following:

- Balancing currents and thermals between phases
- High speed response at the lowest possible switching frequency and output decoupling
- Minimizing thermal switching losses by using lower frequency operation
- Tight load line regulation and accuracy
- High current output due to 3-phase operation
- Reduced output ripple due to multiphase cancellation
- PC board layout noise immunity
- Ease of use and design due to independent component selection
- Flexibility in design by allowing optimization for either low cost or high performance

START-UP SEQUENCE

The ADP3193A follows the VR11 start-up sequence shown in Figure 7. After both the EN and UVLO conditions are met, the DELAY pin goes through one cycle (TD1). The first three clock cycles of TD2 are blanked from the PWM outputs and used for phase detection, as explained in the Phase Detection Sequence section. Then, the soft start ramp is enabled (TD2), and the output increases to the boot voltage of 1.1 V. The boot hold time is determined by the DELAY pin as it goes through a second cycle (TD3). During TD3, the processor VID pins settle to the required VID code. When TD3 is over, the ADP3193A soft starts either up or down to the final VID voltage (TD4). After TD4 has been completed and the PWRGD masking time (equal to VID on-the-fly masking) is completed, a third ramp on the DELAY pin sets the PWRGD blanking (TD5).

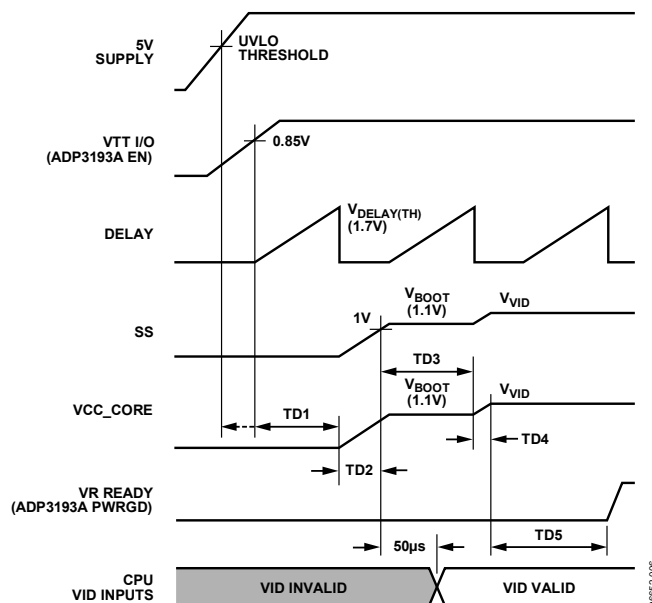

Figure 7. System Start-Up Sequence

PHASE DETECTION SEQUENCE

During startup, the number of operational phases and their phase relationship is determined by the internal circuitry that monitors the PWM outputs. Normally, the ADP3193A operates as a 3-phase PWM controller. Connecting the PWM3 pin to VCC programs 2-phase operation.

Prior to soft start, while EN is low, the PWM3 pin sinks approximately 100 μ A. An internal comparator checks the voltage on PWM3 and compares it with a threshold of 3 V. If the pin is tied to VCC, it is above the threshold. Otherwise, an internal current sink pulls the pin to GND, which is below the threshold. PWM1 and PWM2 are low during the phase detection interval that occurs during the first three clock cycles of TD2. After this time, if PWM3 is not pulled to VCC, the 100 μ A current sink is removed, and it functions as normal PWM output. If PWM3 is pulled to VCC, the 100 μ A current source is removed, and it is put into a high impedance state.

The PWM outputs are logic-level devices intended for driving external gate drivers such as the ADP3120A. Because each phase is monitored independently, operation approaching 100% duty cycle is possible. In addition, more than one output can be on at the same time to allow overlapping phases.

MASTER CLOCK FREQUENCY

The clock frequency of the ADP3193A is set with an external resistor connected from the RT pin to ground. The frequency follows the graph in Figure 3. To determine the frequency per phase, the clock is divided by the number of phases in use. If all phases are in use, divide by 3. If PWM3 is tied to VCC, divide the master clock by 2 for the frequency of the remaining phases.

OUTPUT VOLTAGE DIFFERENTIAL SENSING

The ADP3193A includes differential sensing, high accuracy VID DAC and reference, and a low offset error amplifier. This maintains a worst-case specification of ± 7.7 mV differential sensing error over its full operating output voltage and temperature range. The output voltage is sensed between the FB pin and the FBRTN pin. FB should be connected through a resistor to the regulation point, usually the remote sensing pin of the micro-processor. FBRTN should be connected directly to the remote sensing ground point. The internal VID DAC and precision reference are referenced to FBRTN, which has a minimal current of $65 \mu\text{A}$ to allow accurate remote sensing. The internal error amplifier compares the output of the DAC to the FB pin to regulate the output voltage.

OUTPUT CURRENT SENSING

The ADP3193A provides a dedicated current sense amplifier (CSA) to monitor the total output current for proper voltage positioning vs. load current and for current-limit detection. Sensing the load current at the output gives the total average current being delivered to the load, which is an inherently more accurate method than peak current detection or sampling the current across a sensing element, such as the low-side MOSFET. Depending on the objectives of the system, this amplifier can be configured in several ways:

- Output inductor DCR sensing without a thermistor for lowest cost.
- Output inductor DCR sensing with a thermistor for improved accuracy in tracking inductor temperature.
- Sensing resistor for highest accuracy measurements.

The positive input of the CSA is connected to the CSREF pin, which is connected to the output voltage. The inputs to the amplifier are summed together through resistors from the sensing element, such as the switch node side of the output inductors, to the inverting input CSSUM. The feedback resistor between CSCOMP and CSSUM sets the gain of the amplifier, and a filter capacitor is placed in parallel with this resistor. The gain of the amplifier is programmable by adjusting the feedback resistor.

The difference between CSREF and CSCOMP is also used as a differential input for the current-limit comparator.

To provide the best accuracy for sensing current, the CSA has a low offset input voltage and the sensing gain is set by the external resistor.

CURRENT CONTROL MODE AND THERMAL BALANCE

The ADP3193A has individual inputs (SW1 to SW3) for each phase that are used to monitor the current. This information is combined with an internal ramp to create a current-balancing feedback system that has been optimized for initial current balance accuracy and dynamic thermal balancing during operation. This current balance information is independent of the average output current information used for positioning, as described in the Output Current Sensing section.

The magnitude of the internal ramp can be set to optimize the transient response of the system. It also monitors the supply voltage for feedforward control for changes in the supply. A resistor connected from the power input voltage to the RAMPADJ pin determines the slope of the internal PWM ramp. External resistors can be placed in series with individual phases to create an intentional current imbalance, such as when one phase has better cooling and can support higher currents. Resistors $R_{\text{SW}1}$ through $R_{\text{SW}3}$ (see Figure 10) can be used for adjusting thermal balance in this 3-phase example. It is best to have the ability to add these resistors during the initial design; therefore, ensure that placeholders are provided in the layout.

To increase the current in any given phase, enlarge R_{SW} for that phase (make $R_{\text{SW}} = 0$ for the hottest phase, and do not change it during balancing). Increasing R_{SW} to only 500Ω results in a substantial increase in phase current. Increase each R_{SW} value by small amounts to achieve balance, starting with the coolest phase first.

VOLTAGE CONTROL MODE

A high gain, high bandwidth voltage mode error amplifier is used for the voltage mode control loop. The control input voltage to the positive input is set via the VID logic according to the voltages listed in Table 4.

This voltage is also offset by the droop voltage for active positioning of the output voltage as a function of current, commonly known as active voltage positioning. The output of the amplifier is the COMP pin, which sets the termination voltage for the internal PWM ramps.

The negative input (FB) is tied to the output sense location with Resistor R_B and is used for sensing and controlling the output voltage at this point. A current source (equal to I_{REF}) from the FB pin flowing through R_B is used for setting the no load offset voltage from the VID voltage. The no load voltage is negative with respect to the VID DAC. The main loop compensation is incorporated into the feedback network between FB and COMP pins.

CURRENT REFERENCE

The IREF pin is used to set an internal current reference. This reference current sets I_{FB} , I_{DELAY} , I_{SS} , and I_{LIMIT} . A resistor to ground programs the current based on the 1.5 V output.

$$I_{REF} = \frac{1.5 \text{ V}}{R_{IREF}}$$

Typically, R_{IREF} is set to 100 k Ω to program $I_{REF} = 15 \mu\text{A}$. Therefore,

$$I_{FB} = I_{REF} = 15 \mu\text{A}$$

$$I_{DELAY} = I_{REF} = 15 \mu\text{A}$$

$$I_{SS} = I_{REF} = 15 \mu\text{A}$$

$$I_{LIMIT} = 2/3 (I_{REF}) = 10 \mu\text{A}$$

FAST ENHANCED PWM MODE

Fast enhanced PWM mode is intended to improve the transient response of the ADP3193A to a load step-up. In previous generations of controllers, when a load step-up occurred, the controller could only respond to the load change after the PWM signal was turned on. Enhanced PWM mode allows the controller to immediately respond when a load step-up occurs. This allows the phases to respond more quickly when a load increase takes place.

DELAY TIMER

The delay times for the start-up timing sequence are set with a capacitor from the DELAY pin to ground. In UVLO or when EN is logic low, the DELAY pin is held at ground. After the UVLO and EN signals are asserted, the first delay time (TD1 in Figure 7) is initiated. A current flows out of the DELAY pin to charge C_{DLY} . This current is equal to IREF, which is normally 15 μA . A comparator monitors the DELAY voltage with a threshold of 1.7 V. The delay time is therefore set by the IREF current charging a capacitor from 0 V to 1.7 V. This DELAY pin is used for multiple delay timings (TD1, TD3, and TD5) during the start-up sequence. In addition, DELAY is used for timing the current-limit latch-off, as explained in the Current-Limit, Short-Circuit, and Latch-Off Protection section.

SOFT START

The soft start times for the output voltage are set with a capacitor from the SS pin to ground. After TD1 and the phase detection cycle have been completed, the SS time (TD2 in Figure 7) starts. The SS pin is disconnected from GND, and the capacitor is charged up to the 1.1 V boot voltage by the SS amplifier, which has an output current equal to IREF (normally 15 μA). The voltage at the FB pin follows the ramping voltage on the SS pin, limiting the inrush current during startup. The soft start time depends on the value of the boot voltage and C_{SS} .

When the SS voltage is within 100 mV of the boot voltage, the boot voltage delay time (TD3 in Figure 7) starts. The end of the boot voltage delay time signals the beginning of the second soft start time (TD4 in Figure 7). The SS voltage changes from the boot voltage to the programmed VID DAC voltage (either higher or lower) using the SS amplifier with the output current equal to IREF. The voltage of the FB pin follows the ramping voltage of the SS pin, limiting the inrush current during the transition from the boot voltage to the final DAC voltage. The second soft start time depends on the boot voltage, the programmed VID DAC voltage, and the C_{SS} .

If EN is taken low or if VCC drops below UVLO, DELAY and SS are reset to ground to be ready for another soft start cycle. Figure 8 shows typical start-up waveforms for the ADP3193A.

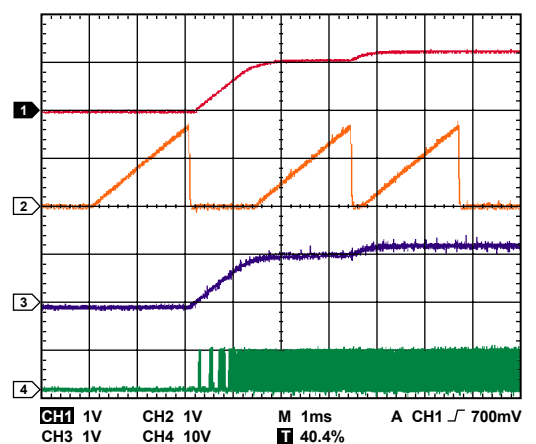

Figure 8. Typical Start-Up Waveforms
(Channel 1: CSREF, Channel 2: DELAY,
Channel 3: SS, Channel 4: Phase 1 Switch Node)

CURRENT-LIMIT, SHORT-CIRCUIT, AND LATCH-OFF PROTECTION

The ADP3193A compares a programmable current-limit setpoint to the voltage from the output of the current sense amplifier. The level of current limit is set with the resistor from the ILIMIT pin to ground. During operation, the current from ILIMIT is equal to 2/3 of IREF, resulting in 10 μA normally. This current through the external resistor sets the ILIMIT voltage, which is internally scaled to provide a current limit threshold of 82.6 mV/V. If the difference in voltage between CSREF and CSCOMP rises above the current-limit threshold, the internal current-limit amplifier controls the internal COMP voltage to maintain the average output current at the limit.

If the limit is reached and TD5 in Figure 7 has completed, a latch-off delay time starts, and the controller shuts down if the fault is not removed. The current-limit delay time shares the DELAY pin timing capacitor with the start-up sequence timing. However, during current limit, the DELAY pin current is reduced to IREF/4. A comparator monitors the DELAY voltage and shuts off the controller when the voltage reaches 1.7 V. Therefore,

ADP3193A

the current-limit latch-off delay time is set by the current of $I_{REF}/4$ charging the delay capacitor from 0 V to 1.7 V. This delay is four times longer than the delay time during the start-up sequence.

The current-limit delay time starts only after the TD5 is complete. If there is a current limit during startup, the ADP3193A goes through TD1 to TD5, and then starts the latch-off time. Because the controller continues to cycle the phases during the latch-off delay time, the controller returns to normal operation and the DELAY capacitor is reset to GND if the short is removed before the 1.7 V threshold is reached.

The latch-off function can be reset by either removing and reapplying the supply voltage to the ADP3193A or by briefly toggling the EN pin low. To disable the short-circuit latch-off function, an external resistor should be placed in parallel with C_{DLY} . This prevents the DELAY capacitor from charging up to the 1.7 V threshold. The addition of this resistor causes a slight increase in the delay times.

During startup, when the output voltage is below 200 mV, a secondary current limit is active. This is necessary because the voltage swing of CSCOMP cannot go below ground. This secondary current limit controls the internal COMP voltage to the PWM comparators to 1.5 V. This limits the voltage drop across the low-side MOSFETs through the current balance circuitry. An inherent per-phase current limit protects individual phases if one or more phases stop functioning because of a faulty component. This limit is based on the maximum normal mode COMP voltage. Typical overcurrent latch-off waveforms are shown in Figure 9.

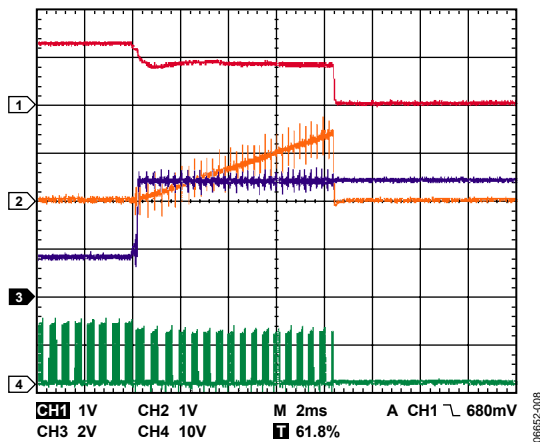

Figure 9. Overcurrent Latch-Off Waveforms
(Channel 1: CSREF, Channel 2: DELAY,
Channel 3: COMP, Channel 4: Phase 1 Switch Node)

DYNAMIC VID

The ADP3193A can dynamically change the VID inputs while the controller is running. This allows the output voltage to change while the supply is running and supplying current to the load. This is commonly referred to as VID on-the-fly (OTF). A VID OTF can occur under light or heavy load conditions. The processor signals the controller by changing the VID inputs in multiple steps from the start code to the finish code. This change can be positive or negative.

When a VID input changes state, the ADP3193A detects the change and ignores the DAC inputs for a minimum of 400 ns. This time prevents a false code due to logic skew while the eight VID inputs are changing. Additionally, the first VID change initiates the PWRGD and crowbar blanking functions for a minimum of 100 μ s to prevent a false PWRGD or crowbar event. Each VID change resets the internal timer.

POWER-GOOD MONITORING

The power-good comparator monitors the output voltage via the CSREF pin. The PWRGD pin is an open-drain output whose high level, when connected to a pull-up resistor, indicates that the output voltage is within the specified nominal limits, which are based on the VID voltage setting. PWRGD goes low if the output voltage is outside of this specified range, if the VID DAC inputs are in no CPU mode, or if the EN pin is pulled low. PWRGD is blanked during a VID OTF event for a period of 200 μ s to prevent false signals during the time the output is changing.

The PWRGD circuitry also incorporates an initial turn-on delay time (TD5) based on the DELAY timer. Prior to the SS voltage reaching the programmed VID DAC voltage and the PWRGD masking time finishing, the PWRGD pin is held low. When the SS pin is within 100 mV of the programmed DAC voltage, the capacitor on the DELAY pin begins to charge. A comparator monitors the DELAY voltage and enables PWRGD when the voltage reaches 1.7 V. The PWRGD delay time is, therefore, set by a current of I_{REF} charging a capacitor from 0 V to 1.7 V.

OUTPUT CROWBAR

To protect the load and output components of the supply, the PWM outputs are driven low, which turns on the low-side MOSFETs when the output voltage exceeds the upper crowbar threshold. This crowbar action stops when the output voltage falls below the release threshold of approximately 300 mV.

Turning on the low-side MOSFETs pulls down the output as the reverse current builds up in the inductors. If the output overvoltage is due to a short in the high-side MOSFET, this action current limits the input supply or blows its fuse, protecting the microprocessor from being destroyed.

OUTPUT ENABLE AND UVLO

For the ADP3193A to begin switching, the input supply (VCC) to the controller must be higher than the UVLO threshold and the EN pin must be higher than its 0.85 V threshold. This initiates a system start-up sequence. If either UVLO or EN is less than its respective threshold, the ADP3193A is disabled. This holds the PWM outputs at ground, shorts the DELAY capacitor to ground, and forces PWRGD and \overline{OD} signals low.

In the application circuit (see Figure 10), the \overline{OD} pin should be connected to the \overline{OD} inputs of the ADP3120A drivers. Grounding \overline{OD} disables the drivers such that both DRVH and DRVL are grounded. This feature is important in preventing the discharge of the output capacitors when the controller is shut off. If the driver outputs are not disabled, a negative voltage can be generated during output due to the high current discharge of the output capacitors through the inductors.

ADP3193A

Table 4. VR11 and VR10.x VID Codes for the ADP3193A

Output	VR11 DAC Codes: VIDSEL = High								VR10.x DAC Codes: VIDSEL = Low						
	VID7	VID6	VID5	VID4	VID3	VID2	VID1	VID0	VID4	VID3	VID2	VID1	VID0	VID5	VID6
Off	0	0	0	0	0	0	0	0	N/A						
Off	0	0	0	0	0	0	0	1	N/A						
1.60000	0	0	0	0	0	0	1	0	0	1	0	1	0	1	1
1.59375	0	0	0	0	0	0	1	1	0	1	0	1	0	1	0
1.58750	0	0	0	0	0	1	0	0	0	1	0	1	1	0	1
1.58125	0	0	0	0	0	1	0	1	0	1	0	1	1	0	0
1.57500	0	0	0	0	0	1	1	0	0	1	0	1	1	1	1
1.56875	0	0	0	0	0	1	1	1	0	1	0	1	1	1	0
1.56250	0	0	0	0	1	0	0	0	0	1	1	0	0	0	1
1.55625	0	0	0	0	1	0	0	1	0	1	1	0	0	0	0
1.55000	0	0	0	0	1	0	1	0	0	1	1	0	0	1	1
1.54375	0	0	0	0	1	0	1	1	0	1	1	0	0	1	0
1.53750	0	0	0	0	1	1	0	0	0	1	1	0	1	0	1
1.53125	0	0	0	0	1	1	0	1	0	1	1	0	1	0	0
1.52500	0	0	0	0	1	1	1	0	0	1	1	0	1	1	1
1.51875	0	0	0	0	1	1	1	1	0	1	1	0	1	1	0
1.51250	0	0	0	1	0	0	0	0	0	1	1	1	0	0	1
1.50625	0	0	0	1	0	0	0	1	0	1	1	1	0	0	0
1.50000	0	0	0	1	0	0	1	0	0	1	1	1	0	1	1
1.49375	0	0	0	1	0	0	1	1	0	1	1	1	0	1	0
1.48750	0	0	0	1	0	1	0	0	0	1	1	1	1	0	1
1.48125	0	0	0	1	0	1	0	1	0	1	1	1	1	0	0
1.47500	0	0	0	1	0	1	1	0	0	1	1	1	1	1	1
1.46875	0	0	0	1	0	1	1	1	0	1	1	1	1	1	0
1.46250	0	0	0	1	1	0	0	0	1	0	0	0	0	0	1
1.45625	0	0	0	1	1	0	0	1	1	0	0	0	0	0	0
1.45000	0	0	0	1	1	0	1	0	1	0	0	0	0	1	1
1.44375	0	0	0	1	1	0	1	1	1	0	0	0	0	1	0
1.43750	0	0	0	1	1	1	0	0	1	0	0	0	1	0	1
1.43125	0	0	0	1	1	1	0	1	1	0	0	0	1	0	0
1.42500	0	0	0	1	1	1	1	0	1	0	0	0	1	1	1
1.41875	0	0	0	1	1	1	1	1	1	0	0	0	1	1	0
1.41250	0	0	1	0	0	0	0	0	1	0	0	1	0	0	1
1.40625	0	0	1	0	0	0	0	1	1	0	0	1	0	0	0
1.40000	0	0	1	0	0	0	1	0	1	0	0	1	0	1	1
1.39375	0	0	1	0	0	0	1	1	1	0	0	1	0	1	0
1.38750	0	0	1	0	0	1	0	0	1	0	0	1	1	0	1
1.38125	0	0	1	0	0	1	0	1	1	0	0	1	1	0	0
1.37500	0	0	1	0	0	1	1	0	1	0	0	1	1	1	1
1.36875	0	0	1	0	0	1	1	1	1	0	0	1	1	1	0
1.36250	0	0	1	0	1	0	0	0	1	0	1	0	0	0	1
1.35625	0	0	1	0	1	0	0	1	1	0	1	0	0	0	0
1.35000	0	0	1	0	1	0	1	0	1	0	1	0	0	1	1
1.34375	0	0	1	0	1	0	1	1	1	0	1	0	0	1	0
1.33750	0	0	1	0	1	1	0	0	1	0	1	0	1	0	1
1.33125	0	0	1	0	1	1	0	1	1	0	1	0	1	0	0
1.32500	0	0	1	0	1	1	1	0	1	0	1	0	1	1	1
1.31875	0	0	1	0	1	1	1	1	1	0	1	0	1	1	0
1.31250	0	0	1	1	0	0	0	0	1	0	1	1	0	0	1
1.30625	0	0	1	1	0	0	0	1	1	0	1	1	0	0	0
1.30000	0	0	1	1	0	0	1	0	1	0	1	1	0	1	1
1.29375	0	0	1	1	0	0	1	1	1	0	1	1	0	1	0
1.28750	0	0	1	1	0	1	0	0	1	0	1	1	1	0	1
1.28125	0	0	1	1	0	1	0	1	1	0	1	1	1	0	0
1.27500	0	0	1	1	0	1	1	0	1	0	1	1	1	1	1
1.26875	0	0	1	1	0	1	1	1	1	0	1	1	1	1	0
1.26250	0	0	1	1	1	0	0	0	1	1	0	0	0	0	1

Output	VR11 DAC Codes: VIDSEL = High								VR10.x DAC Codes: VIDSEL = Low						
	VID7	VID6	VID5	VID4	VID3	VID2	VID1	VID0	VID4	VID3	VID2	VID1	VID0	VID5	VID6
1.25625	0	0	1	1	1	0	0	1	1	1	0	0	0	0	0
1.25000	0	0	1	1	1	0	1	0	1	1	0	0	0	1	1
1.24375	0	0	1	1	1	0	1	1	1	1	0	0	0	1	0
1.23750	0	0	1	1	1	1	0	0	1	1	0	0	1	0	1
1.23125	0	0	1	1	1	1	0	1	1	1	0	0	1	0	0
1.22500	0	0	1	1	1	1	1	0	1	1	0	0	1	1	1
1.21875	0	0	1	1	1	1	1	1	1	1	0	0	1	1	0
1.21250	0	1	0	0	0	0	0	0	1	1	0	1	0	0	1
1.20625	0	1	0	0	0	0	0	1	1	1	0	1	0	0	0
1.20000	0	1	0	0	0	0	1	0	1	1	0	1	0	1	1
1.19375	0	1	0	0	0	0	1	1	1	1	0	1	0	1	0
1.18750	0	1	0	0	0	1	0	0	1	1	0	1	1	0	1
1.18125	0	1	0	0	0	1	0	1	1	1	0	1	1	0	0
1.17500	0	1	0	0	0	1	1	0	1	1	0	1	1	1	1
1.16875	0	1	0	0	0	1	1	1	1	1	0	1	1	1	0
1.16250	0	1	0	0	1	0	0	0	1	1	1	0	0	0	1
1.15625	0	1	0	0	1	0	0	1	1	1	1	0	0	0	0
1.15000	0	1	0	0	1	0	1	0	1	1	1	0	0	1	1
1.14375	0	1	0	0	1	0	1	1	1	1	1	0	0	1	0
1.13750	0	1	0	0	1	1	0	0	1	1	1	0	1	0	1
1.13125	0	1	0	0	1	1	0	1	1	1	1	0	1	0	0
1.12500	0	1	0	0	1	1	1	0	1	1	1	0	1	1	1
1.11875	0	1	0	0	1	1	1	1	1	1	1	0	1	1	0
1.11250	0	1	0	1	0	0	0	0	1	1	1	1	0	0	1
1.10625	0	1	0	1	0	0	0	1	1	1	1	1	0	0	0
1.10000	0	1	0	1	0	0	1	0	1	1	1	1	0	1	1
1.09375	0	1	0	1	0	0	1	1	1	1	1	1	0	1	0
Off					N/A				1	1	1	1	1	0	1
Off					N/A				1	1	1	1	1	0	0
Off					N/A				1	1	1	1	1	1	1
Off					N/A				1	1	1	1	1	1	0
1.08750	0	1	0	1	0	1	0	0	0	0	0	0	0	0	1
1.08125	0	1	0	1	0	1	0	1	0	0	0	0	0	0	0
1.07500	0	1	0	1	0	1	1	0	0	0	0	0	0	1	1
1.06875	0	1	0	1	0	1	1	1	0	0	0	0	0	1	0
1.06250	0	1	0	1	1	0	0	0	0	0	0	0	1	0	1
1.05625	0	1	0	1	1	0	0	1	0	0	0	0	1	0	0
1.05000	0	1	0	1	1	0	1	0	0	0	0	0	1	1	1
1.04375	0	1	0	1	1	0	1	1	0	0	0	0	1	1	0
1.03750	0	1	0	1	1	1	0	0	0	0	0	1	0	0	1
1.03125	0	1	0	1	1	1	0	1	0	0	0	1	0	0	0
1.02500	0	1	0	1	1	1	1	0	0	0	0	1	0	1	1
1.01875	0	1	0	1	1	1	1	1	0	0	0	1	0	1	0
1.01250	0	1	1	0	0	0	0	0	0	0	0	1	1	0	1
1.00625	0	1	1	0	0	0	0	1	0	0	0	1	1	0	0
1.00000	0	1	1	0	0	0	1	0	0	0	0	1	1	1	1
0.99375	0	1	1	0	0	0	1	1	0	0	0	1	1	1	0
0.98750	0	1	1	0	0	1	0	0	0	0	1	0	0	0	1
0.98125	0	1	1	0	0	1	0	1	0	0	1	0	0	0	0
0.97500	0	1	1	0	0	1	1	0	0	0	1	0	0	1	1
0.96875	0	1	1	0	0	1	1	1	0	0	1	0	0	1	0
0.96250	0	1	1	0	1	0	0	0	0	0	1	0	1	0	1
0.95625	0	1	1	0	1	0	0	1	0	0	1	0	1	0	0
0.95000	0	1	1	0	1	0	1	0	0	0	1	0	1	1	1
0.94375	0	1	1	0	1	0	1	1	0	0	1	0	1	1	0
0.93750	0	1	1	0	1	1	0	0	0	0	1	1	0	0	1
0.93125	0	1	1	0	1	1	0	1	0	0	1	1	0	0	0
0.92500	0	1	1	0	1	1	1	0	0	0	1	1	0	1	1

ADP3193A

Output	VR11 DAC Codes: VIDSEL = High								VR10.x DAC Codes: VIDSEL = Low						
	VID7	VID6	VID5	VID4	VID3	VID2	VID1	VID0	VID4	VID3	VID2	VID1	VID0	VID5	VID6
0.91875	0	1	1	0	1	1	1	1	0	0	1	1	0	1	0
0.91250	0	1	1	1	0	0	0	0	0	0	1	1	1	0	1
0.90625	0	1	1	1	0	0	0	1	0	0	1	1	1	0	0
0.90000	0	1	1	1	0	0	1	0	0	0	1	1	1	1	1
0.89375	0	1	1	1	0	0	1	1	0	0	1	1	1	1	0
0.88750	0	1	1	1	0	1	0	0	0	1	0	0	0	0	1
0.88125	0	1	1	1	0	1	0	1	0	1	0	0	0	0	0
0.87500	0	1	1	1	0	1	1	0	0	1	0	0	0	1	1
0.86875	0	1	1	1	0	1	1	1	0	1	0	0	0	1	0
0.86250	0	1	1	1	1	0	0	0	0	1	0	0	1	0	1
0.85625	0	1	1	1	1	0	0	1	0	1	0	0	1	0	0
0.85000	0	1	1	1	1	0	1	0	0	1	0	0	1	1	1
0.84375	0	1	1	1	1	0	1	1	0	1	0	0	1	1	0
0.83750	0	1	1	1	1	1	0	0	0	1	0	1	0	0	1
0.83125	0	1	1	1	1	1	0	1	0	1	0	1	0	0	0
0.82500	0	1	1	1	1	1	1	0							N/A
0.81875	0	1	1	1	1	1	1	1							N/A
0.81250	1	0	0	0	0	0	0	0							N/A
0.80625	1	0	0	0	0	0	0	1							N/A
0.80000	1	0	0	0	0	0	1	0							N/A
0.79375	1	0	0	0	0	0	1	1							N/A
0.78750	1	0	0	0	0	1	0	0							N/A
0.78125	1	0	0	0	0	1	0	1							N/A
0.77500	1	0	0	0	0	1	1	0							N/A
0.76875	1	0	0	0	0	1	1	1							N/A
0.76250	1	0	0	0	1	0	0	0							N/A
0.75625	1	0	0	0	1	0	0	1							N/A
0.75000	1	0	0	0	1	0	1	0							N/A
0.74375	1	0	0	0	1	0	1	1							N/A
0.73750	1	0	0	0	1	1	0	0							N/A
0.73125	1	0	0	0	1	1	0	1							N/A
0.72500	1	0	0	0	1	1	1	0							N/A
0.71875	1	0	0	0	1	1	1	1							N/A
0.71250	1	0	0	1	0	0	0	0							N/A
0.70625	1	0	0	1	0	0	0	1							N/A
0.70000	1	0	0	1	0	0	1	0							N/A
0.69375	1	0	0	1	0	0	1	1							N/A
0.68750	1	0	0	1	0	1	0	0							N/A
0.68125	1	0	0	1	0	1	0	1							N/A
0.67500	1	0	0	1	0	1	1	0							N/A
0.66875	1	0	0	1	0	1	1	1							N/A
0.66250	1	0	0	1	1	0	0	0							N/A
0.65625	1	0	0	1	1	0	0	1							N/A
0.65000	1	0	0	1	1	0	1	0							N/A
0.64375	1	0	0	1	1	0	1	1							N/A
0.63750	1	0	0	1	1	1	0	0							N/A
0.63125	1	0	0	1	1	1	0	1							N/A
0.62500	1	0	0	1	1	1	1	0							N/A
0.61875	1	0	0	1	1	1	1	1							N/A
0.61250	1	0	1	0	0	0	0	0							N/A
0.60625	1	0	1	0	0	0	0	1							N/A
0.60000	1	0	1	0	0	0	1	0							N/A
0.59375	1	0	1	0	0	0	1	1							N/A
0.58750	1	0	1	0	0	1	0	0							N/A
0.58125	1	0	1	0	0	1	0	1							N/A
0.57500	1	0	1	0	0	1	1	0							N/A
0.56875	1	0	1	0	0	1	1	1							N/A
0.56250	1	0	1	0	1	0	0	0							N/A

Output	VR11 DAC Codes: VIDSEL = High								VR10.x DAC Codes: VIDSEL = Low						
	VID7	VID6	VID5	VID4	VID3	VID2	VID1	VID0	VID4	VID3	VID2	VID1	VID0	VID5	VID6
0.55625	1	0	1	0	1	0	0	1	N/A						
0.55000	1	0	1	0	1	0	1	0	N/A						
0.54375	1	0	1	0	1	0	1	1	N/A						
0.53750	1	0	1	0	1	1	0	0	N/A						
0.53125	1	0	1	0	1	1	0	1	N/A						
0.52500	1	0	1	0	1	1	1	0	N/A						
0.51875	1	0	1	0	1	1	1	1	N/A						
0.51250	1	0	1	1	0	0	0	0	N/A						
0.50625	1	0	1	1	0	0	0	1	N/A						
0.50000	1	0	1	1	0	0	1	0	N/A						
Off	1	1	1	1	1	1	1	0	1	1	1	1	1	1	0
Off	1	1	1	1	1	1	1	1	1	1	1	1	1	1	1

APPLICATION INFORMATION

The design parameters for a typical Intel VRD 11 compliant CPU application are as follows:

- Input voltage (V_{IN}) = 12 V
- VID setting voltage (V_{VID}) = 1.400 V
- Duty cycle (D) = 0.117
- Nominal output voltage at no load (V_{ONL}) = 1.381 V
- Nominal output voltage at 65 A load (V_{OFL}) = 1.316 V
- Static output voltage drop based on a 1.0 mΩ load line (R_O) from no load to full load (V_D) = $V_{ONL} - V_{OFL}$ = 1.381 V – 1.316 V = 65 mV
- Maximum output current (I_O) = 65 A
- Maximum output current step (ΔI_O) = 50 A
- Maximum output current slew rate (S_R) = 200 A/μs
- Number of phases (n) = 3
- Switching frequency per phase (f_{SW}) = 330 kHz

SETTING THE CLOCK FREQUENCY

The ADP3193A uses a fixed-frequency control architecture. The frequency is set by an external timing resistor (R_T). The clock frequency and the number of phases determine the switching frequency per phase, which relates directly to switching losses as well as to the sizes of the inductors, the input capacitors, and the output capacitors. With $n = 3$ for three phases, a clock frequency of 990 kHz sets the switching frequency (f_{SW}) of each phase to 330 kHz, which represents a practical trade-off between the switching losses and the sizes of the output filter components. Figure 3 shows that to achieve a 990 kHz oscillator frequency, the correct value for R_T is 169 kΩ (closest 1% resistor is 169 kΩ). Alternatively, the value for R_T can be calculated using

$$R_T = \frac{1}{n \times f_{SW} \times 6 \text{ pF}} \quad (1)$$

where 6 pF is the internal IC component values. For good initial accuracy and frequency stability, a 1% resistor is recommended.

SOFT START DELAY TIME

The value of C_{SS} sets the soft start time. The ramp is generated with a 15 μA internal current source. The value for C_{SS} can be found using

$$C_{SS} = 15 \mu\text{A} \times \frac{TD2}{V_{BOOT}} \quad (2)$$

where $TD2$ is the desired soft start time, and V_{BOOT} is internally set to 1.1 V.

Assuming a desired $TD2$ time of 1.4 ms, C_{SS} is 19 nF. The closest standard value for C_{SS} is 18 nF. Although C_{SS} also controls the time delay for $TD4$ (determined by the final VID voltage), the minimum specification for $TD4$ is 0 ns. This means that as long as the $TD2$ time requirement is met, $TD4$ is within the specification.

CURRENT-LIMIT LATCH-OFF DELAY TIMES

The start-up and current-limit delay times are determined by the capacitor connected to the DELAY pin. The first step is to set C_{DLY} for the $TD1$, $TD3$, and $TD5$ delay times (see Figure 7). The DELAY ramp (I_{DELAY}) is generated using a 15 μA internal current source. The value for C_{DLY} can be approximated using

$$C_{DLY} = I_{DELAY} \times \frac{TD(x)}{V_{DELAY(TH)}} \quad (3)$$

where:

$TD(x)$ is the desired delay time for $TD1$, $TD3$, and $TD5$.

$V_{DELAY(TH)}$ is the DELAY threshold voltage and is given as 1.7 V.

In this example, 2 ms is chosen for all three delay times, which meets Intel specifications. Solving for C_{DLY} results in a value of 17.6 nF. The closest standard value for C_{DLY} is 18 nF.

When the ADP3193A surpasses the current limit, the internal current source changes from 15 μA to 3.75 μA. As a result, the latch-off delay time becomes four times longer than the start-up delay time. Note that longer latch-off delay times can be achieved by placing a resistor in parallel with C_{DLY} .

INDUCTOR SELECTION

The choice of inductance for the inductor determines the ripple current in the inductor. Less inductance leads to more ripple current, which increases the output ripple voltage and conduction losses in the MOSFETs. However, using smaller inductors allows the converter to meet a specified peak-to-peak transient deviation with less total output capacitance. Conversely, a higher inductance means lower ripple current and reduced conduction losses, but more output capacitance is required to meet the same peak-to-peak transient deviation.

In any multiphase converter, a practical value for the peak-to-peak inductor ripple current is less than 50% of the maximum dc current in the same inductor. Equation 4 shows the relationship between the inductance, oscillator frequency, and peak-to-peak ripple current in the inductor.

$$I_R = \frac{V_{VID} \times (1-D)}{f_{SW} \times L} \quad (4)$$

Equation 5 can be used to determine the minimum inductance based on a given output ripple voltage.

$$L \geq \frac{V_{VID} \times R_O \times (1-(n \times D))}{f_{SW} \times V_{RIPPLE}} \quad (5)$$

Solving Equation 5 for an output ripple voltage of 10 mV p-p yields

$$L \geq \frac{1.4 \text{ V} \times 1.0 \text{ m}\Omega \times (1 - 0.35)}{330 \text{ kHz} \times 10 \text{ mV}} = 276 \text{ nH}$$

If the resulting ripple voltage is less than what is designed for, the inductor can be made smaller until the ripple value is met. This allows optimal transient response and minimum output decoupling.

The smallest possible inductor should be used to minimize the number of output capacitors. Choosing a 320 nH inductor is a good choice for a starting point, and it provides a calculated ripple current of 11.7 A. The inductor should not saturate at the peak current of 27.6 A, and it should be able to handle the sum of the power dissipation caused by the average current of 21.7 A in the winding and core loss.

Another important factor in the inductor design is the dc resistance (DCR), which is used for measuring the phase currents. Too large of a DCR causes excessive power losses, whereas too small of a value leads to increased measurement error. A good rule is to have the DCR (R_L) be about $1 \times$ to $1\frac{1}{2} \times$ the droop resistance (R_O). This example uses an inductor with a DCR of 1.4 m Ω .

Designing an Inductor

After the inductance and DCR are known, the next step is either to design an inductor or to find a standard inductor that best meets the overall design goals. It is also important to have the inductance and DCR tolerance specified to control the accuracy of the system. Reasonable tolerances that most manufacturers can meet are 20% inductance and 7% DCR at room temperature.

The first decision in designing the inductor is choosing the core material. Several possibilities for providing low core loss at high frequencies include the powder cores (from Micrometals, Inc., for example, or Kool-Mu[®] from Magnetics[®]) and the gapped soft ferrite cores (for example, 3F3 or 3F4 from Philips). Low frequency powdered iron cores should be avoided due to their high core loss, especially when the inductor value is relatively low and the ripple current is high.

The best choice for a core geometry is a closed-loop type of inductor, such as a potentiometer core; a PQ, U, or E core; or a toroid. A good compromise between price and performance is a core with a toroidal shape.

Many useful magnetics design references are available for quickly designing a power inductor, such as

- Magnetic Designer Software from Intusoft
- *Designing Magnetic Components for High Frequency DC-DC Converters*, by William T. McLyman, K G Magnetics, Inc., ISBN 1883107008

Selecting a Standard Inductor

The following power inductor manufacturers can provide design consultation and upon request deliver power inductors optimized for high power applications.

- Coilcraft, Inc.
- Coiltronics
- Sumida Corporation

CURRENT SENSE AMPLIFIER

Most designs require the regulator output voltage measured at the CPU pins to droop when the output current increases. The specified voltage drop corresponds to a dc output resistance (R_O), also referred to as a load line.

The output current is measured by summing the voltage across each inductor and passing the signal through a low-pass filter. This summer filter is the CS amplifier configured with Resistor $R_{PH(x)}$ (summer) and Resistors R_{CS} and C_{CS} (filters). The impedance gain of the regulator is set by the following equations, where R_L is the DCR of the output inductors:

$$R_O = \frac{R_{CS}}{R_{PH(x)}} \times R_L \quad (6)$$

$$C_{CS} = \frac{L}{R_L \times R_{CS}} \quad (7)$$

The user has the flexibility to choose either R_{CS} or $R_{PH(x)}$. However, it is best to select R_{CS} equal to 100 k Ω , and then solve for $R_{PH(x)}$ by rearranging Equation 6. In the following example, $R_O = 1 \text{ m}\Omega$ to equal the design load line.

$$R_{PH(x)} = \frac{R_L}{R_O} \times R_{CS}$$

$$R_{PH(x)} = \frac{1.4 \text{ m}\Omega}{1.0 \text{ m}\Omega} \times 100 \text{ k}\Omega = 140 \text{ k}\Omega$$

Next, use Equation 7 to solve for C_{CS} .

$$C_{CS} = \frac{320 \text{ nH}}{1.4 \text{ m}\Omega \times 100 \text{ k}\Omega} = 2.28 \text{ nF}$$

It is best to include two locations for C_{CS} in the layout so that standard values can be used in parallel to better achieve the desired value. For best accuracy, C_{CS} should be a 5% or 10% NPO capacitor. This example uses a 5% combination for C_{CS} of two 1 nF capacitors in parallel. Recalculating R_{CS} and $R_{PH(x)}$ using this capacitor combination yields 114 k Ω and 160 k Ω . The closest standard 1% value for $R_{PH(x)}$ is 158 k Ω .

C_{OUT} SELECTION

The required output decoupling for the regulator is typically recommended by Intel for various processors and platforms. Use some simple design guidelines to determine the requirements. These guidelines are based on having both bulk capacitors and ceramic capacitors in the system.

First, select the total amount of ceramic capacitance. This is based on the number and type of capacitor to be used. The best location for ceramic capacitors is inside the socket, with twelve to eighteen 1206-size pieces being the physical limit. Other capacitors can be placed along the outer edge of the socket as well.

To determine the minimum amount of ceramic capacitance required, start with a worst-case load step that occurs immediately after a switching cycle has stopped. The ceramic capacitance then delivers the charge to the load while the load is ramping up until the VR responds with the next switching cycle.

Equation 15 provides the designer with a rough approximation for determining the minimum ceramic capacitance. Due to the complexity of the PCB parasitics and bulk capacitors, the actual amount of ceramic capacitance required can vary.

$$C_{Z(MIN)} \geq \frac{1}{2R_O} \times \left[\frac{1}{f_{SW}} \times \left(\frac{1}{n} - D \right) - \frac{\Delta I_O}{2S_R} \right] \quad (15)$$

The typical ceramic capacitors consist of multiple 10 μ F or 22 μ F capacitors. For this example, Equation 15 yields 265 μ F, so twenty-six 10 μ F ceramic capacitors suffice.

Next, there is an upper limit imposed on the total amount of bulk capacitance (C_X), considering the VID on-the-fly voltage stepping of the output (voltage step, V_V , in time, t_V , with error of V_{ERR}).

A lower limit is based on meeting the capacitance for load release at a given maximum load step (ΔI_O) and a maximum allowable overshoot. The total amount of load release voltage is $\Delta V_O = \Delta I_O \times R_O + \Delta V_{rl}$, where ΔV_{rl} is the maximum allowable overshoot voltage.

$$C_{X(MIN)} \geq \left(\frac{L \times \Delta I_O}{n \times \left(R_O + \frac{\Delta V_{rl}}{\Delta I_O} \right) \times V_{VID}} - C_Z \right) \quad (16)$$

$$C_{X(MAX)} \leq \frac{L}{nk^2 R_O^2} \times \frac{V_V}{V_{VID}} \times \left(\sqrt{1 + \left(t_V \frac{V_{VID}}{V_V} \times \frac{nKR_O}{L} \right)^2} - 1 \right) - C_Z \quad (17)$$

$$\text{where } k = -\ln \left(\frac{V_{ERR}}{V_V} \right).$$

To meet the conditions of these equations and transient response, the ESR of the bulk capacitor bank (R_X) should be less than two times the droop resistance (R_O). If $C_{X(MIN)}$ is larger than $C_{X(MAX)}$, the system cannot meet the VID on-the-fly specification and to maintain the output ripple may require the use of a smaller inductor or more phases (in addition to increasing the switching frequency).

This example uses twenty-six 10 μ F 1206 MLC capacitors ($C_Z = 260 \mu$ F). The VID on-the-fly step change is 450 mV in 230 μ s with a settling error of 2.5 mV. The maximum allowable load release overshoot for this example is 50 mV; therefore, solving for the bulk capacitance yields

$$C_{X(MIN)} \leq \left(\frac{320 \text{ nH} \times 50 \text{ A}}{3 \times \left(1.0 \text{ m}\Omega + \frac{50 \text{ mV}}{50 \text{ A}} \right) \times 1.4 \text{ V}} - 260 \mu\text{F} \right) = 1.64 \text{ mF}$$

$$C_{X(MAX)} \leq \frac{320 \text{ nH} \times 450 \text{ mV}}{3 \times 5.2^2 \times (1.0 \text{ m}\Omega)^2 \times 1.4 \text{ V}} \times$$

$$\left(\sqrt{1 + \left(\frac{230 \mu\text{s} \times 1.4 \text{ V} \times 3 \times 5.2 \times 1.0 \text{ m}\Omega}{450 \text{ mV} \times 320 \text{ nH}} \right)^2} - 1 \right) - 260 \mu\text{F} = 42.7 \text{ mF}$$

where $k = 5.2$.

Using eight 560 μ F aluminum-poly capacitors with a typical ESR of 6 m Ω each yields $C_X = 4.48 \text{ mF}$ with an $R_X = 0.75 \text{ m}\Omega$.

One last check should be made to ensure that the ESL of the bulk capacitors (L_X) is low enough to limit the high frequency ringing during a load change.

This is tested using

$$L_X \leq C_Z \times R_O^2 \times Q^2 \quad (18)$$

$$L_X \leq 260 \mu\text{F} \times (1 \text{ m}\Omega)^2 \times \frac{4}{3} = 347 \text{ pH}$$

where Q^2 is limited to $4/3$ to ensure a critically damped system.

In this example, L_X is approximately 240 pH for the eight aluminum-poly capacitors, which satisfies this limitation. If the L_X of the chosen bulk capacitor bank is too large, the number of ceramic capacitors needs to be increased, or lower ESL bulks need to be used if there is excessive undershoot during a load transient.

For this multimode control technique, all ceramic designs can be used if the conditions of Equation 15 through Equation 18 are satisfied.

POWER MOSFETS

For our example, the N-channel power MOSFETs have been selected for one high-side switch and two low-side switches per phase. The main selection parameters for the power MOSFETs are $V_{GS(TH)}$, Q_G , C_{ISS} , C_{RSS} , and $R_{DS(ON)}$. The minimum gate drive voltage (the supply voltage to the ADP3120A) dictates whether standard threshold or logic-level threshold MOSFETs must be used. With $V_{GATE} \sim 10$ V, logic-level threshold MOSFETs ($V_{GS(TH)} < 2.5$ V) are recommended.

The maximum output current (I_O) determines the $R_{DS(ON)}$ requirement for the low-side (synchronous) MOSFETs. With the ADP3193A, currents are balanced between phases; therefore, the current in each low-side MOSFET is the output current divided by the total number of MOSFETs (n_{SF}). With conduction losses being dominant, Equation 19 shows the total power that is dissipated in each synchronous MOSFET in terms of the ripple current per phase (I_R) and the average total output current (I_O):

$$P_{SF} = (1-D) \times \left[\left(\frac{I_O}{n_{SF}} \right)^2 + \frac{1}{12} \times \left(\frac{n I_R}{n_{SF}} \right)^2 \right] \times R_{DS(SF)} \quad (19)$$

Knowing the maximum output current being designed for and the maximum allowed power dissipation, the user can find the required $R_{DS(ON)}$ for the MOSFET. For D-PAK MOSFETs up to an ambient temperature of 50°C, a safe limit for P_{SF} is 1 W to 1.5 W at 120°C junction temperature. Therefore, for this example (56 A maximum), $R_{DS(SF)}$ (per MOSFET) is less than 4.7 mΩ. This $R_{DS(SF)}$ is also at a junction temperature of about 120°C. As a result, users need to account for this when making this selection. This example uses two low-side MOSFETs at 4.8 mΩ, each at 120°C.

Another important factor for the synchronous MOSFET is the input capacitance and feedback capacitance. The ratio of the feedback to the input must be small (less than 10% is recommended) to prevent accidentally turning on the synchronous MOSFETs when the switch node goes high.

In addition, the time to switch the synchronous MOSFETs off should not exceed the nonoverlap dead time of the MOSFET driver (45 ns typical for the ADP3120A). The output impedance of the driver is approximately 2 Ω, and the typical MOSFET input gate resistances are about 1 Ω to 2 Ω. Therefore, a total gate capacitance of less than 6000 pF should be adhered to. Because two MOSFETs are in parallel, the input capacitance for each synchronous MOSFET should be limited to 6000 pF.

The high-side (main) MOSFET must be able to handle two main power dissipation components: conduction and switching losses. The switching loss is related to the amount of time for the main MOSFET to turn on and off and to the current and voltage that are being switched. Basing the switching speed on the rise and fall times of the gate driver impedance and

MOSFET input capacitance, the following expression provides an approximate value for the switching loss per main MOSFET:

$$P_{S(MF)} = 2 \times f_{SW} \times \frac{V_{CC} \times I_O}{n_{MF}} \times R_G \times \frac{n_{MF}}{n} \times C_{ISS} \quad (20)$$

where:

n_{MF} is the total number of main MOSFETs.

R_G is the total gate resistance (2 Ω for the ADP3120A and about 1 Ω for typical high speed switching MOSFETs, making $R_G = 3$ Ω).

C_{ISS} is the input capacitance of the main MOSFET.

Adding more main MOSFETs (n_{MF}) does not help the switching loss per MOSFET because the additional gate capacitance slows switching. Use lower gate capacitance devices to reduce switching loss.

The conduction loss of the main MOSFET is given by the following:

$$P_{C(MF)} = D \times \left[\left(\frac{I_O}{n_{MF}} \right)^2 + \frac{1}{12} \times \left(\frac{n \times I_R}{n_{MF}} \right)^2 \right] \times R_{DS(MF)} \quad (21)$$

where $R_{DS(MF)}$ is the on resistance of the MOSFET.

Typically, for main MOSFETs, the highest speed (low C_{ISS}) device is preferred, but such devices usually have higher on resistance. Select a device that meets the total power dissipation (about 1.5 W for a single D-PAK) when combining the switching and conduction losses.

For this example, an NTD40N03L is selected as the main MOSFET (three total, $n_{MF} = 3$), with $C_{ISS} = 584$ pF (maximum) and $R_{DS(MF)} = 19$ mΩ (maximum at $T_j = 120^\circ\text{C}$). An NTD110N02L is selected as the synchronous MOSFET (three total, $n_{SF} = 3$), with $C_{ISS} = 2710$ pF (maximum) and $R_{DS(SF)} = 4.8$ mΩ (maximum at $T_j = 120^\circ\text{C}$). The synchronous MOSFET C_{ISS} is less than 6000 pF, satisfying this requirement.

Solving for the power dissipation per MOSFET at $I_O = 56$ A and $I_R = 11.7$ A yields 1.53 W for each synchronous MOSFET and 1.06 W for each main MOSFET. As a guide, limit the MOSFET power dissipation to 1.5 W. The values calculated in Equation 20 and Equation 21 will comply with this guideline.

Finally, consider the power dissipation in the driver for each phase. This is best expressed as Q_G for the MOSFETs and is given by Equation 22.

$$P_{DRV} = \left[\frac{f_{SW}}{2 \times n} \times (n_{MF} \times Q_{GMF} + n_{SF} \times Q_{GSF}) + I_{CC} \right] \times V_{CC} \quad (22)$$

where Q_{GMF} is the total gate charge for each main MOSFET, and Q_{GSF} is the total gate charge for each synchronous MOSFET

Also shown is the standby dissipation factor ($I_{CC} \times V_{CC}$) of the driver. For the ADP3120A, the maximum dissipation should be

ADP3193A

less than 400 mW. In this example, with $I_{CC} = 7$ mA, $Q_{GMF} = 5.8$ nC, and $Q_{GSF} = 48$ nC, there is 191 mW in each driver, which is below the 400 mW dissipation limit. See the ADP3120A data sheet for more details.

RAMP RESISTOR SELECTION

The ramp resistor (R_R) is used for setting the size of the internal PWM ramp. The value of this resistor should be chosen to provide the best combination of thermal balance, stability, and transient response. Equation 23 is used for determining the optimum value.

$$R_R = \frac{A_R \times L}{3 \times A_D \times R_{DS} \times C_R} \quad (23)$$

$$R_R = \frac{0.2 \times 320 \text{ nH}}{3 \times 5 \times 4.8 \text{ m}\Omega \times 5 \text{ pF}} = 178 \text{ k}\Omega$$

where:

A_R is the internal ramp amplifier gain.

A_D is the current-balancing amplifier gain.

R_{DS} is the total low-side MOSFET on resistance.

C_R is the internal ramp capacitor value.

The internal ramp voltage magnitude can be calculated as follows:

$$V_R = \frac{A_R \times (1-D) \times V_{VID}}{R_R \times C_R \times f_{SW}} \quad (24)$$

$$V_R = \frac{0.2 \times (1-0.117) \times 1.4 \text{ V}}{178 \text{ k}\Omega \times 5 \text{ pF} \times 330 \text{ kHz}} = 842 \text{ mV}$$

The size of the internal ramp can be increased or decreased. If it is increased, stability and noise rejection improve, but the transient response degrades. Conversely, if the ramp size is decreased, the transient response improves, but noise rejection and stability degrade.

In the denominator of Equation 23, the factor of 3 sets a ramp size that produces an optimal balance for good stability, transient response, and thermal balance.

COMP PIN RAMP

In addition to the internal ramp, there is a ramp signal on the COMP pin due to the droop voltage and output voltage ramps. This ramp amplitude adds to the internal ramp to produce the following overall ramp signal at the PWM input:

$$V_{RT} = \frac{V_R}{\left(1 - \frac{2 \times (1-n \times D)}{n \times f_{SW} \times C_X \times R_O}\right)} \quad (25)$$

In this example, the overall ramp signal is 1.19 V. However, if the ramp size is smaller than 0.5 V, increase the ramp size to be at least 0.5 V by decreasing the ramp resistor for noise immunity.

CURRENT-LIMIT SETPOINT

To select the current-limit setpoint, first find the resistor value for R_{LIM} . The current-limit threshold for the ADP3193A is set with a constant current source flowing out of the ILIMIT pin, which sets up a voltage (V_{LIM}) across R_{LIM} with a gain of 82.6 mV/V (A_{LIM}). Therefore, increasing R_{LIM} now increases the current limit. R_{LIM} can be found using the following equation:

$$R_{LIM} = \frac{V_{CL}}{A_{LIM} \times I_{LIMIT}} = \frac{I_{LIM} \times R_{CSA}}{82.6 \text{ mV}} \quad (26)$$

In this equation, I_{LIM} is the peak average current limit for the supply output and is equal to the dc current limit plus the output ripple current. In this example, choosing a dc current limit of 88.3 A and having a ripple current of 11.7 A yields an I_{LIM} of 100 A, resulting in an R_{LIM} of 121 k Ω , for which 121 k Ω is chosen as the nearest 1% value.

The per-phase initial duty cycle limit and peak current during a load step are determined by

$$D_{MAX} = D \times \frac{V_{COMP(MAX)} - V_{BIAS}}{V_{RT}} \quad (27)$$

$$I_{PHMAX} \cong \frac{D_{MAX}}{f_{SW}} \times \frac{(V_{IN} - V_{VID})}{L} \quad (28)$$

For the ADP3193A, the maximum COMP voltage ($V_{COMP(MAX)}$) is 3.4 V, and the COMP pin bias voltage (V_{BIAS}) is 1.1 V. In this example, the maximum duty cycle is 0.23. Because this is small due to the V_{RT} being much larger than 0.5 V, reduce the ramp resistor to get closer to 0.5 V V_{RT} and to obtain a larger duty cycle. Choosing a ramp resistor of 267 k Ω results in a V_{RT} of 0.79 V, a D_{MAX} of 0.34, and a peak current of 34 A.

The limit of the peak per-phase current during the secondary current limit is determined by

$$I_{PHLIM} \cong \frac{V_{COMP(CLAMPED)} - V_{BIAS}}{A_D \times R_{DS(MAX)}} \quad (29)$$

For the ADP3193A, the current balancing amplifier gain (A_D) is 5 and the clamped COMP pin voltage is 2 V. Using an $R_{DS(MAX)}$ of 5.6 m Ω (low-side on resistance at 150°C) results in a per-phase peak current limit of 36 A. This current level can be reached only with an absolute short at the output, and the current-limit latch-off function shuts down the regulator before overheating can occur.

FEEDBACK LOOP COMPENSATION DESIGN

Optimized compensation of the ADP3193A allows the best possible response of the regulator's output to a load change. The basis for determining the optimum compensation is to make the regulator and output decoupling appear as an output impedance that is entirely resistive over the widest possible frequency range, including dc, and that is equal to the droop resistance (R_O). With the resistive output impedance, the output voltage droops in proportion to the load current at any load current slew rate. This ensures optimal positioning and minimizes the output decoupling.

Because of the multimode feedback structure of the ADP3193A, it is necessary to set the feedback compensation so that the converter

output impedance works in parallel with the output decoupling to make the load look entirely resistive. In addition, it is necessary to compensate for several poles and zeros created by the output inductor and the decoupling capacitors (output filter).

A Type III compensator on the voltage feedback is adequate for proper compensation of the output filter.

Equation 30 to Equation 34 are intended to yield an optimal starting point for the design; some adjustments may be necessary to account for PCB and component parasitic effects (see the Tuning Procedure for ADP3193A section).

First, compute the time constants for all the poles and zeros in the system using Equation 30 to Equation 34.

$$R_E = n \times R_O + A_D \times R_{DS} + \frac{R_L \times V_{RT}}{V_{VID}} + \frac{2 \times L \times (1 - n \times D) \times V_{RT}}{n \times C_X \times R_O \times V_{VID}} \quad (30)$$

$$R_E = 3 \times 1 \text{ m}\Omega + 5 \times 4.8 \text{ m}\Omega + \frac{1.4 \text{ m}\Omega \times 0.79 \text{ V}}{1.4 \text{ V}} + \frac{2 \times 320 \text{ nH} \times (1 - 0.35) \times 0.79 \text{ V}}{3 \times 4.48 \text{ mF} \times 1 \text{ m}\Omega \times 1.4 \text{ V}} = 45.3 \text{ m}\Omega$$

$$T_A = C_X \times (R_O - R') + \frac{L_X}{R_O} \times \frac{R_O - R'}{R_X} = 4.48 \text{ mF} \times (1 \text{ m}\Omega - 0.5 \text{ m}\Omega) + \frac{347 \text{ pH}}{1 \text{ m}\Omega} \times \frac{1 \text{ m}\Omega - 0.5 \text{ m}\Omega}{0.75 \text{ m}\Omega} = 2.47 \text{ }\mu\text{s} \quad (31)$$

$$T_B = (R_X + R' - R_O) \times C_X = (0.75 \text{ m}\Omega + 0.5 \text{ m}\Omega - 1 \text{ m}\Omega) \times 4.48 \text{ mF} = 1120 \text{ ns} \quad (32)$$

$$T_C = \frac{V_{RT} \times \left(L - \frac{A_D \times R_{DS}}{2 \times f_{SW}} \right)}{V_{VID} \times R_E} = \frac{0.79 \text{ V} \times \left(320 \text{ nH} - \frac{5 \times 4.8 \text{ m}\Omega}{2 \times 330 \text{ kHz}} \right)}{1.4 \text{ V} \times 45.3 \text{ m}\Omega} = 3.53 \text{ }\mu\text{s} \quad (33)$$

$$T_D = \frac{C_X \times C_Z \times R_O^2}{C_X \times (R_O - R') + C_Z \times R_O} = \frac{4.48 \text{ mF} \times 260 \text{ }\mu\text{F} \times (1 \text{ m}\Omega)^2}{4.48 \text{ mF} \times (1 \text{ m}\Omega - 0.5 \text{ m}\Omega) + 260 \text{ }\mu\text{F} \times 1 \text{ m}\Omega} = 466 \text{ ns} \quad (34)$$

where:

R' is the PCB resistance from the bulk capacitors to the ceramics and is approximately 0.5 m Ω (assuming a 4-layer, 1 oz motherboard).

R_{DS} is the total low-side MOSFET on resistance per phase.

$A_D = 5$.

$V_{RT} = 0.79 \text{ V}$.

$L_X = 347 \text{ pH}$ for the eight aluminum-poly capacitors.

ADP3193A

The compensation values can then be solved using

$$C_A = \frac{n \times R_O \times T_A}{R_E \times R_B} = \frac{3 \times 1 \text{ m}\Omega \times 2.47 \text{ }\mu\text{s}}{45.3 \text{ m}\Omega \times 1.27 \text{ k}\Omega} = 128 \text{ pF} \quad (35)$$

$$R_A = \frac{T_C}{C_A} = \frac{3.53 \text{ }\mu\text{s}}{128 \text{ pF}} = 27.5 \text{ k}\Omega \quad (36)$$

$$C_B = \frac{T_B}{R_B} = \frac{1120 \text{ ns}}{1.27 \text{ k}\Omega} = 882 \text{ pF} \quad (37)$$

$$C_{FB} = \frac{T_D}{R_A} = \frac{466 \text{ ns}}{27.5 \text{ k}\Omega} = 16.9 \text{ pF} \quad (38)$$

These equations result in the starting values prior to tuning the design that account for layout and other parasitic effects (see the Tuning Procedure for ADP3193A section). The final values selected after tuning are

$$C_A = 220 \text{ pF}$$

$$R_A = 22.1 \text{ k}\Omega$$

$$C_B = 560 \text{ pF}$$

$$C_{FB} = 15 \text{ pF}$$

Figure 12 and Figure 13 show the typical transient response using these compensation values.

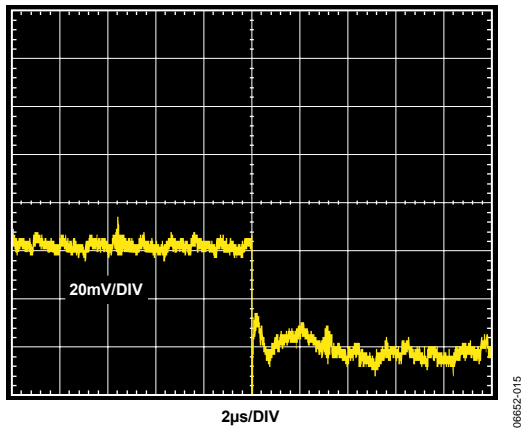

Figure 12. Typical Transient Response for Design Example Load Step

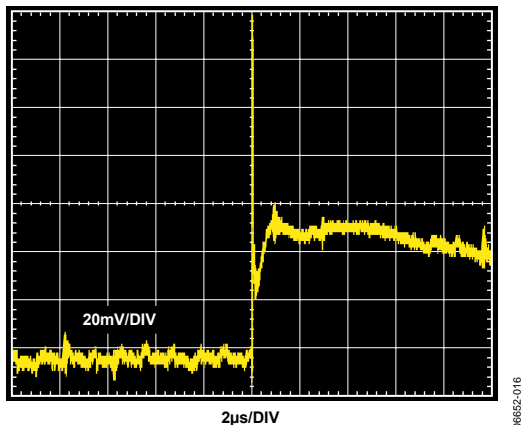

Figure 13. Typical Transient Response for Design Example Load Release

C_{IN} SELECTION AND INPUT CURRENT di/dt REDUCTION

In continuous inductor current mode, the source current of the high-side MOSFET is approximately a square wave with a duty ratio equal to $n \times V_{OUT}/V_{IN}$ and an amplitude of one- n^{th} the maximum output current. To prevent large voltage transients, use a low ESR input capacitor sized for the maximum rms current. The maximum rms capacitor current is given by

$$I_{CRMS} = D \times I_O \times \sqrt{\frac{1}{N \times D} - 1} \quad (39)$$

$$I_{CRMS} = 0.117 \times 65 \text{ A} \times \sqrt{\frac{1}{3 \times 0.117} - 1} = 10.3 \text{ A}$$

The capacitor manufacturer's ripple-current ratings are often based on only 2000 hours of life. As a result, it is advisable to further derate the capacitor or to choose a capacitor rated at a higher temperature than is required. Several capacitors can be placed in parallel to meet size or height requirements in the design. In this example, the input capacitor bank is formed by two 2700 μF , 16 V aluminum electrolytic capacitors and eight 4.7 μF ceramic capacitors.

To reduce the input current, di/dt, to a level below the recommended maximum of 0.1 A/ μs , an additional small inductor ($L > 370 \text{ nH}$ at 18 A) should be inserted between the converter and the supply bus. This inductor also acts as a filter between the converter and the primary power source.

SHUNT RESISTOR DESIGN

The ADP3193A uses a shunt to generate 5 V from the 12 V supply range. A trade-off can be made between the power dissipated in the shunt resistor and the UVLO threshold. Figure 14 shows the typical resistor value needed to realize certain UVLO voltages and the maximum power dissipated in the shunt resistor for these UVLO voltages.

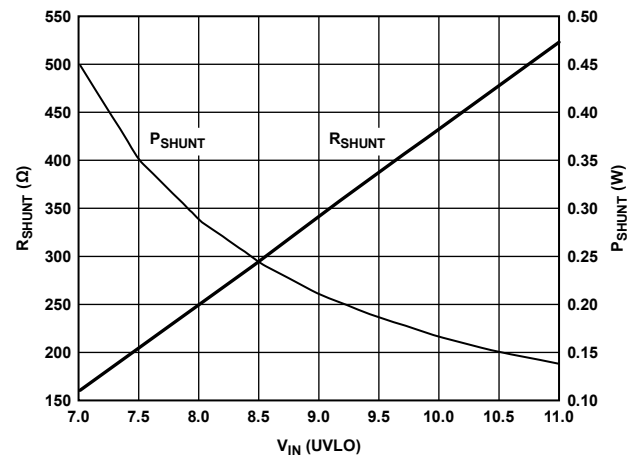

Figure 14. Typical Shunt Resistor Value and Power Dissipation for Different UVLO Voltages

The maximum power dissipated is calculated using Equation 40.

$$P_{MAX} = \frac{(V_{IN(MAX)} - V_{CC(MIN)})^2}{R_{SHUNT}} \quad (40)$$

where:

$V_{IN(MAX)}$ is the maximum voltage from the 12 V input supply

(if the 12 V input supply is $12\text{ V} \pm 5\%$, $V_{IN(MAX)} = 12.6\text{ V}$;

if the 12 V input supply is $12\text{ V} \pm 10\%$, $V_{IN(MAX)} = 13.2\text{ V}$).

$V_{CC(MIN)}$ is the minimum V_{CC} voltage of the ADP3193A. This is specified as 4.75 V.

R_{SHUNT} is the shunt resistor value.

The CECC standard specification for power rating in surface-mount resistors is 0.1 W for 0603-size resistors, 0.125 W for 0805-size resistors, and 0.25 W for 1206-size resistors.

TUNING PROCEDURE FOR ADP3193A

Set Up and Test the Circuit

1. Build a circuit based on the compensation values computed from the design spreadsheet.
2. Connect a dc load to the circuit.
3. Turn on the ADP3193A and verify that it operates properly.
4. Check for jitter with no load and full load conditions.

Set the DC Load Line

1. Measure the output voltage with no load (V_{NL}) and verify that it is within the specified tolerance range.

2. Measure the output voltage with a full load when the device is cold (V_{FLCOLD}). Allow the board to run for ~10 minutes at full load, and then measure the output when the device is hot (V_{FLHOT}). If the difference between the two measured voltages is more than a few millivolts, adjust R_{CS1} and R_{CS2} using Equation 41 and Equation 43.

$$R_{CS2(NEW)} = R_{CS2(OLD)} \times \frac{V_{NL} - V_{FLCOLD}}{V_{NL} - V_{FLHOT}} \quad (41)$$

3. Repeat Step 2 until no adjustment of R_{CS1} and R_{CS2} is needed.
4. Compare the output voltage with no load to that with a full load using 5 A steps. Compute the load line slope for each change, and then calculate the average to determine the overall load line slope (R_{OMEAS}).
5. If the difference between R_{OMEAS} and R_O is more than 0.05 m Ω , use Equation 42 to adjust the R_{PH} values.

$$R_{PH(NEW)} = R_{PH(OLD)} \times \frac{R_{OMEAS}}{R_O} \quad (42)$$

6. Repeat Step 6 and Step 7 until no adjustment of R_{PH} is needed. Once this is achieved, do not change R_{PH} , R_{CS1} , R_{CS2} , or R_{TH} for the remainder of the procedure.
7. Measure the output ripple with no load and with a full load with scope, making sure both are within specifications.

$$R_{CS1(NEW)} = \frac{1}{\frac{R_{CS1(OLD)} + R_{TH(25^\circ C)}}{R_{CS1(OLD)} \times R_{TH(25^\circ C)} + (R_{CS1(OLD)} - R_{CS2(NEW)}) \times (R_{CS1(OLD)} - R_{TH(25^\circ C)})} - \frac{1}{R_{TH(25^\circ C)}}} \quad (43)$$

Set the AC Load Line

1. Remove the dc load from the circuit and connect the dynamic load.
2. Connect the scope to the output voltage and set it to dc-coupling mode with the time scale of 100 $\mu\text{s}/\text{div}$.
3. Set the dynamic load for a transient step of about 40 A at 1 kHz with 50% duty cycle.
4. Measure the output waveform. (Note that use of a dc offset on the scope may be necessary to see the waveform.) Try to use a vertical scale of 100 mV/div or finer. This waveform should look similar to Figure 15.

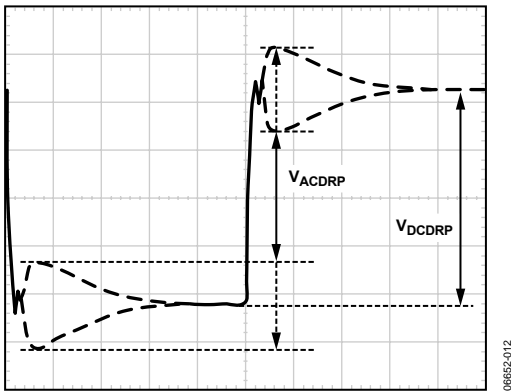

Figure 15. AC Load Line Waveform

5. Use the horizontal cursors to measure V_{ACDRP} and V_{DCDRP} , as shown in Figure 15. Do not measure the undershoot or overshoot that occurs immediately after this step.
6. If the difference between V_{ACDRP} and V_{DCDRP} is more than a few millivolts, use Equation 44 to adjust C_{CS} . It may be necessary to try several parallel values to obtain an adequate one, because there are limited standard capacitor values available. It is a good idea to have locations for two capacitors in the layout for this reason.

$$C_{CS(NEW)} = C_{CS(OLD)} \times \frac{V_{ACDRP}}{V_{DCDRP}} \quad (44)$$
7. Repeat Step 5 and Step 6 until no further adjustment of C_{CS} is needed. Once this is achieved, do not change C_{CS} for the remainder of the procedure.
8. Set the dynamic load step to its maximum step size (but do not use a step size that is larger than needed) and verify that the output waveform is square, meaning V_{ACDRP} and V_{DCDRP} are equal.

Set the Initial Transient

1. With the dynamic load set at the maximum step size, expand the scope time scale to either 2 $\mu\text{s}/\text{div}$ or 5 $\mu\text{s}/\text{div}$. This may result in a waveform that has two overshoots and

one minor undershoot before achieving the final desired value after V_{DROOP} (see Figure 16).

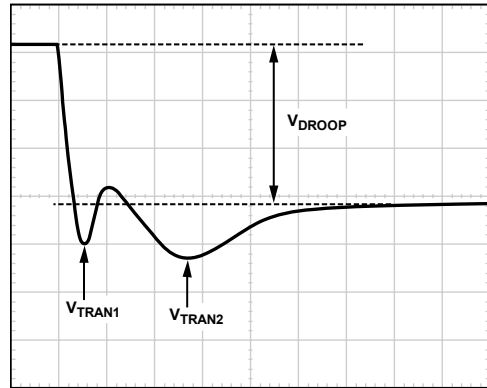

Figure 16. Transient Setting Waveform

2. If both overshoots are larger than desired, try the following adjustments in the order shown:
 - Increase the ramp resistor by 25% (R_{RAMP}).
 - For V_{TRAN1} , increase C_B or increase the switching frequency.
 - For V_{TRAN2} , increase R_A by 25% and decrease C_A by 25%.

If these adjustments do not change the response, it is because the system is limited by the output decoupling. Check the output response and the switching nodes each time a change is made to ensure that the response is stable.

3. For load release (see Figure 17), if $V_{TRANREL}$ is larger than the allowed overshoot, there is not enough output capacitance. Either increase the capacitance directly or decrease the inductor values. If the inductors are changed, however, it will be necessary to redesign the circuit using the information from the spreadsheet and to repeat all tuning guide procedures.

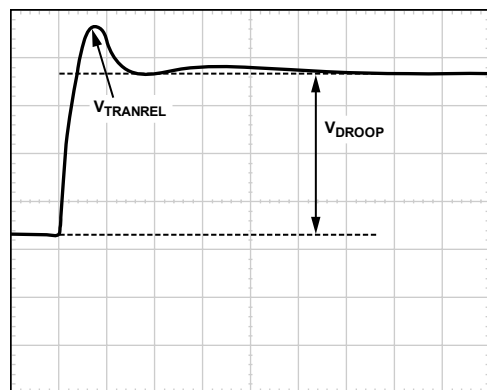

Figure 17. Transient Setting Waveform

Because the ADP3193A turns off all of the phases (switches inductors to ground), no ripple voltage is present during load release. Therefore, the user does not have to add headroom for ripple, which allows load release $V_{TRANREL}$ to be larger than

V_{TRAN1} by the amount of ripple while still meeting the specifications.

If V_{TRAN1} and V_{TRANREL} are less than the desired final droop, this implies that capacitors can be removed. When removing capacitors, also check the output ripple voltage to ensure that it is still within specifications.

LAYOUT AND COMPONENT PLACEMENT

The following guidelines are recommended for optimal performance of a switching regulator in a PC system.

General Recommendations

For good results, a PCB with at least four layers is recommended. This provides the needed versatility for control circuitry interconnections with optimal placement, power planes for ground, input and output power, and wide interconnection traces in the remainder of the power-delivery current paths. Keep in mind that each square unit of 1 oz copper trace has a resistance of $\sim 0.53 \text{ m}\Omega$ at room temperature.

When high currents must be routed between PCB layers, use vias liberally to create several parallel current paths so that the resistance and inductance introduced by these current paths are minimized and the via current rating is not exceeded.

If critical signal lines (including the output voltage sense lines of the ADP3193A) must cross through power circuitry, it is best to interpose a signal ground plane between those signal lines and the traces of the power circuitry. This serves as a shield to minimize noise injection into the signals at the expense of increasing signal ground noise.

An analog ground plane should be used around and under the ADP3193A as a reference for the components associated with the controller. This plane should be tied to the nearest output-decoupling capacitor ground and should not be tied to any other power circuitry to prevent power currents from flowing into it.

The components around the ADP3193A should be located close to the controller with short traces. The most important traces to keep short and away from other traces are those to the FB and CSSUM pins. The output capacitors should be connected as close as possible to the load (or connector) that receives the power, for example, as close as possible to a microprocessor core. If the load is distributed, the capacitors should also be distributed and placed in greater proportion where the load tends to be more dynamic.

Avoid crossing any signal lines over the switching power path loop (described in the Power Circuitry Recommendations section).

Power Circuitry Recommendations

The switching power path on the PCB should be routed to encompass the shortest possible length to minimize radiated switching noise energy (that is, EMI) and conduction losses in the board. Failure to take proper precautions often results in EMI problems for the entire PC system and noise-related operational problems in the power-converter control circuitry. The switching power path is the loop formed by the current path through the input capacitors and the power MOSFETs, including all interconnecting PCB traces and planes. Using short, wide interconnection traces is especially critical in this path for two reasons: it minimizes the inductance in the switching loop, which can cause high energy ringing, and it accommodates the high current demand with minimal voltage loss.

When a power-dissipating component, such as a power MOSFET, is soldered to a PCB, it is recommended to use vias liberally both directly on the mounting pad and immediately surrounding it. Two important reasons for this are improved current rating through the vias and improved thermal performance from vias extended to the opposite side of the PCB, where a plane can more readily transfer the heat to the air. Make a mirror image on the opposite side of the PCB of any pad being used to heat-sink the MOSFETs. This helps achieve the best thermal dissipation in the air around the board. To further improve thermal performance, use the largest pad area possible.

The output power path should also be routed to encompass a short distance. The output power path is formed by the current path through the inductor, the output capacitors, and the load.

For best EMI containment, a solid power ground plane should be used as one of the inner layers, extending fully under all the power components.

Signal Circuitry Recommendations

The output voltage is sensed and regulated between the FB and FBRTN pins, which connect to the signal ground at the load. To avoid differential mode noise pickup in the sensed signal, the loop area should be small. Therefore, the FB and FBRTN traces should be routed adjacent to each other on top of the power ground plane back to the controller.

The feedback traces from the switch nodes should be connected as close as possible to the inductor, and the CSREF signal should be connected to the output voltage at the nearest inductor to the controller.

ADP3193A

OUTLINE DIMENSIONS

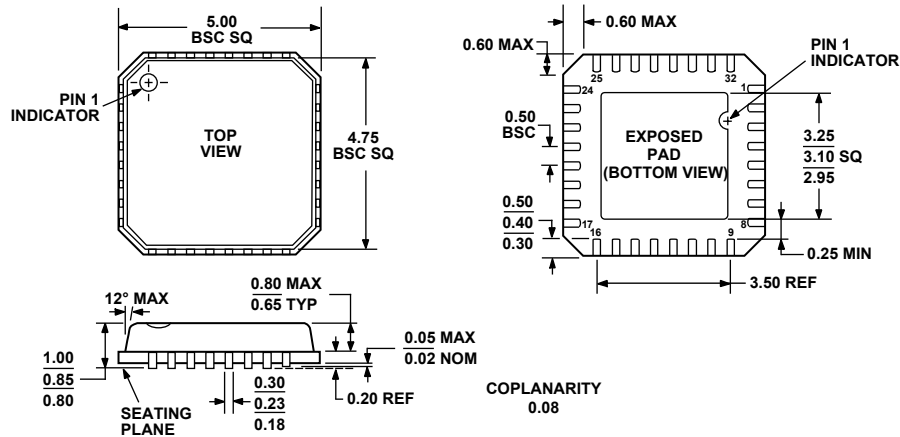

COMPLIANT TO JEDEC STANDARDS MO-220-VHHD-2

Figure 18. 32-Lead Lead Frame Chip Scale Package [LFCSP_VQ]
5 mm × 5 mm Body, Very Thin Quad
(CP-32-2)
Dimensions shown in millimeters

ORDERING GUIDE

Model	Temperature Range	Package Description	Package Option	Ordering Quantity
ADP3193AJCPZ-RL ¹	0°C to 85°C	32-Lead Lead Frame Chip Scale Package [LFCSP_VQ]	CP-32-2	2,500

¹ Z = RoHS Compliant Part.

NOTES

ADP3193A

NOTES

Looking for pricing, stock, or lifecycle information?

Click below to explore more details on WIN SOURCE:

 View [ADP3193AJCPZ](#) on WIN SOURCE

 [ON Semiconductor](#) Information

Optimize Your Supply Chain with WIN SOURCE Solutions

-  Global Sourcing Solution
-  Obsolete Management
-  Cost Control Management
-  Shortage Management
-  Alternative Solution
-  Excess Inventory Management