

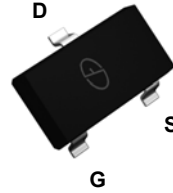


# THE DATASHEET OF BSS84AKW

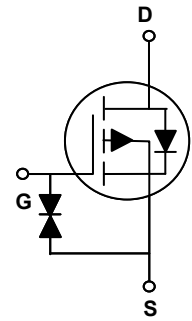


## Main Product Characteristics

$V_{(BR)DSS}$	-60V
$R_{DS(ON)}$	$4\Omega @ V_{GS} = -10V$
$I_D$	-0.3A



SOT-323



Schematic Diagram

## Features and Benefits

- Advanced MOSFET process technology
- Ideal for load switch, hand-held devices and LED applications
- Low on-resistance with low gate charge
- Fast switching and reverse body recovery



## Description

The BSS84AKW utilizes the latest techniques to achieve high cell density and low on-resistance. These features make this device extremely efficient and reliable for use in high efficiency switch mode power supply and a wide variety of other applications.

## Absolute Maximum Ratings ( $T_C = 25^\circ\text{C}$ unless otherwise specified)

Parameter	Symbol	Value	Unit
Drain-Source Voltage	$V_{DS}$	-60	V
Gate-Source Voltage	$V_{GS}$	$\pm 20$	V
Drain Current – Continuous ( $T_A = 25^\circ\text{C}$ )	$I_D$	-0.3	A
Drain Current – Continuous ( $T_A = 70^\circ\text{C}$ )		-0.24	A
Drain Current – Pulsed <sup>1</sup>	$I_{DM}$	-0.6	A
Power Dissipation ( $T_A = 25^\circ\text{C}$ )	$P_D$	0.27	W
Power Dissipation – Derate above $25^\circ\text{C}$	$P_D$	2.16	mW/ $^\circ\text{C}$
Storage Temperature Range	$T_{STG}$	-55 to +150	$^\circ\text{C}$
Operating Junction Temperature Range	$T_J$	-55 to +150	$^\circ\text{C}$

## Thermal Characteristics

Parameter	Symbol	Typ.	Max.	Unit
Thermal Resistance Junction to Ambient	$R_{\theta JA}$	---	450	$^\circ\text{C}/\text{W}$

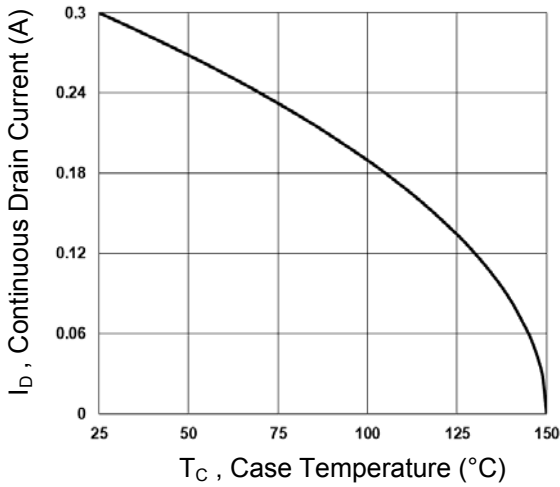
**Electrical Characteristics** ( $T_J=25^\circ\text{C}$  unless otherwise specified)

Parameter	Symbol	Conditions	Min.	Typ.	Max.	Unit
<b>Off Characteristics</b>						
Drain-Source Breakdown Voltage	$BV_{DSS}$	$V_{GS}=0V$ , $I_D=-250\mu A$	-60	---	---	V
$BV_{DSS}$ Temperature Coefficient	$\Delta BV_{DSS}/\Delta T_J$	Reference to $25^\circ\text{C}$ , $I_D=-1\text{mA}$	---	0.03	---	$V/^\circ\text{C}$
Drain-Source Leakage Current	$I_{DSS}$	$V_{DS}=-60V$ , $V_{GS}=0V$ , $T_J=25^\circ\text{C}$	---	---	-1	$\mu A$
		$V_{DS}=-48V$ , $V_{GS}=0V$ , $T_J=125^\circ\text{C}$	---	---	-30	$\mu A$
Gate-Source Leakage Current	$I_{GSS}$	$V_{GS}=\pm 20V$ , $V_{DS}=0V$	---	---	$\pm 10$	$\mu A$
<b>On Characteristics</b>						
Static Drain-Source On-Resistance	$R_{DS(ON)}$	$V_{GS}=-10V$ , $I_D=-0.3A$	---	2.3	4	$\Omega$
		$V_{GS}=-4.5V$ , $I_D=-0.2A$	---	2.9	5	
Gate Threshold Voltage	$V_{GS(th)}$	$V_{GS}=V_{DS}$ , $I_D=-250\mu A$	-1	-1.5	-2	V
$V_{GS(th)}$ Temperature Coefficient	$\Delta V_{GS(th)}$		---	-2.1	---	$\text{mV}/^\circ\text{C}$
<b>Dynamic and Switching Characteristics</b>						
Input Capacitance	$C_{iss}$	$V_{DS}=-25V$ , $V_{GS}=0V$ , $F=1\text{MHz}$	---	41	---	$\mu\text{F}$
Output Capacitance	$C_{oss}$		---	13	---	
Reverse Transfer Capacitance	$C_{rss}$		---	8	---	
<b>Drain-Source Diode Characteristics and Maximum Ratings</b>						
Continuous Source Current	$I_S$	$V_G=V_D=0V$ , Force Current	---	---	-0.3	A
Pulsed Source Current	$I_{SM}$		---	---	-0.6	A
Diode Forward Voltage	$V_{SD}$	$V_{GS}=0V$ , $I_S=1A$ , $T_J=25^\circ\text{C}$	---	---	-1.3	V

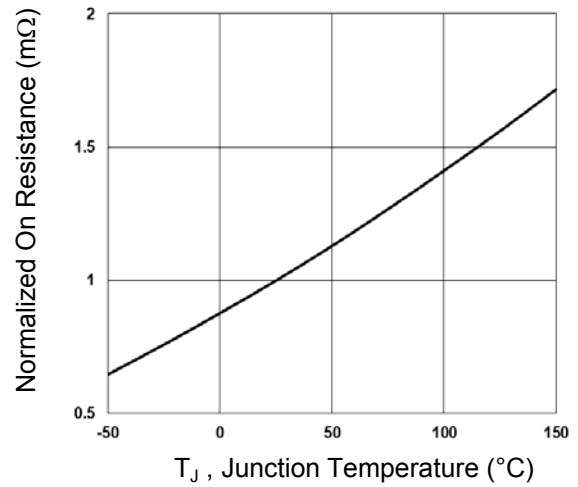
Note:

1. Repetitive Rating: Pulsed width limited by maximum junction temperature.
2. The data tested by pulsed, pulse width  $\leq 300\mu\text{s}$ , duty cycle  $\leq 2\%$ .
3. Essentially independent of operating temperature.

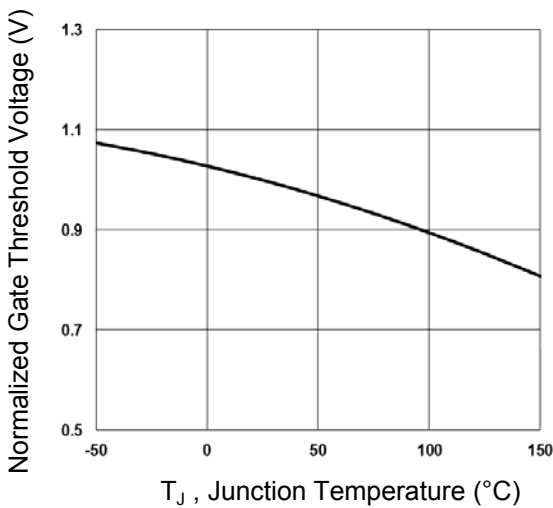
**Typical Electrical and Thermal Characteristic Curves**



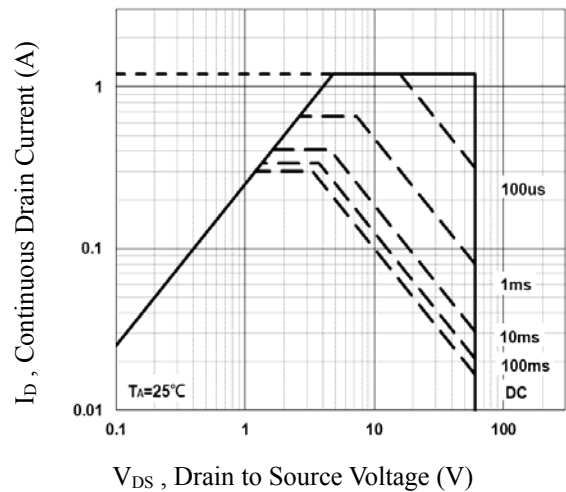
**Fig.1 Continuous Drain Current vs.  $T_C$**



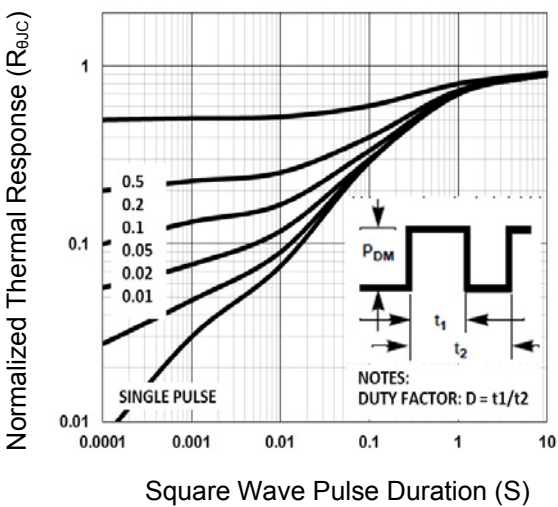
**Fig.2 Normalized  $R_{DS(ON)}$  vs.  $T_J$**



**Fig.3 Normalized  $V_{th}$  vs.  $T_J$**

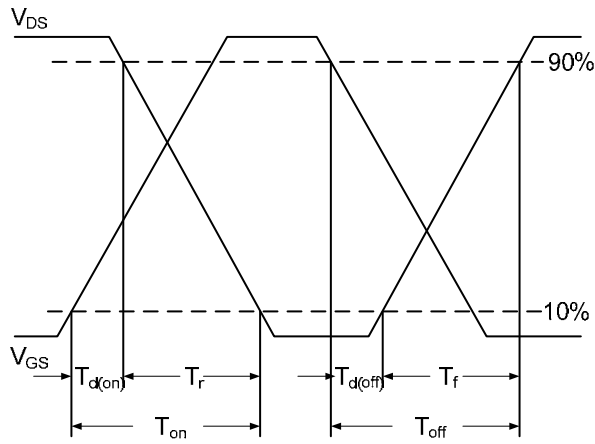


**Fig.4 Maximum Safe Operation Area**

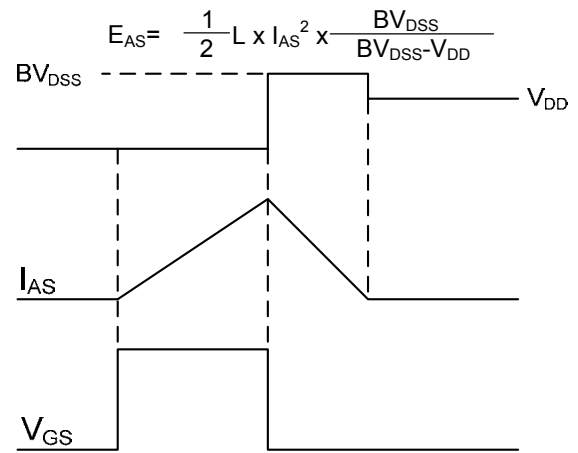


**Fig.5 Normalized Transient Impedance**

**Typical Electrical and Thermal Characteristic Curves**



**Fig. 6 Switching Time Waveform**

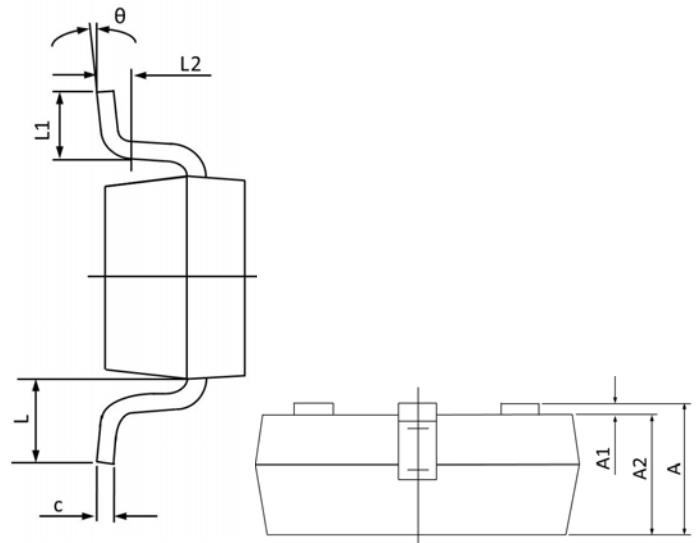
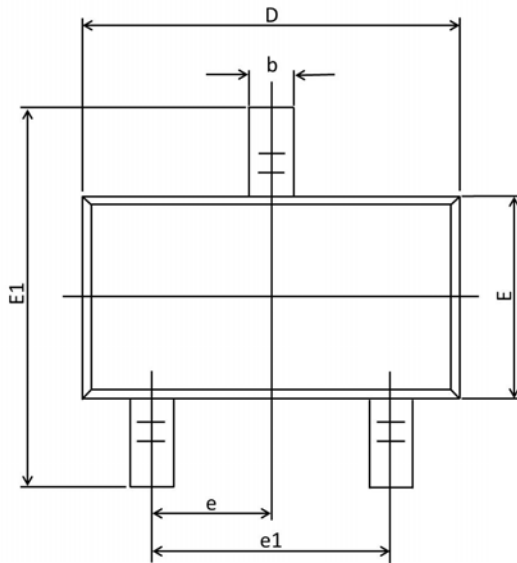


**Fig.7  $E_{AS}$  Waveform**



**Package Outline Dimensions**


**SOT-323**



Symbol	Dimensions In Millimeters		Dimensions In Inches	
	MAX	MIN	MAX	MIN
A	1.100	0.800	0.043	0.031
A1	0.100	0.000	0.004	0.000
A2	1.000	0.800	0.039	0.031
b	0.400	0.200	0.016	0.008
c	0.250	0.080	0.010	0.003
D	2.200	1.800	0.087	0.071
E	1.350	1.150	0.053	0.045
E1	2.450	1.800	0.096	0.071
e	0.65BSC		0.026BSC	
e1	1.400	1.200	0.055	0.047
L	0.525REF.		0.021REF.	
L1	0.460	0.150	0.018	0.006
L2	0.200	0.000	0.008	0.000
θ	8°	0°	8°	0°

## Looking for pricing, stock, or lifecycle information?

Click below to explore more details on WIN SOURCE:

-  [View BSS84AKW on WIN SOURCE](#)
-  [GOOD-ARK Electronics Information](#)

## Optimize Your Supply Chain with WIN SOURCE Solutions

-  Global Sourcing Solution
-  Obsolete Management
-  Cost Control Management
-  Shortage Management
-  Alternative Solution
-  Excess Inventory Management