



THE DATASHEET OF UM1750S-00



350mA, Micropower, Very Low Dropout Linear Regulator***UM1650S-xx SOT23-3******UM1750S-xx SOT23-5******UM1750Y-xx SOT89-5******UM1750DA-xx DFN6 2.0×2.0*****General Description**

The UM1650/UM1750 series are very low dropout linear regulators designed for low power portable applications. Typical output noise is only 195 μ V_{RMS} and maximum dropout is just 110mV(Typ) at the load current of 150mA. The internal P-channel MOSFET pass transistor requires no base current, allowing the device to draw only 190 μ A during normal operation at the maximum load current of 350mA. With a shutdown control pin, the UM1750 consumes less than 1 μ A current in shutdown mode.

Other features include high output voltage accuracy, excellent transient response, under voltage lockout, stability with ultralow ESR ceramic capacitors as small as 1 μ F, short-circuit and thermal overload protection and output current limiting.

The UM1650 series are available in a low profile SOT23-3 package. The UM1750 series are available in low profile SOT23-5, SOT89-5 and DFN6 2.0×2.0 packages.

Applications

- Bluetooth/802.11 Cards
- PDAs and Notebook Computers
- Portable Instruments and Battery-Powered Systems
- Cellular Phones

Features

- Very Low Dropout: 150mV (Max) at 150mA
- Maximum Input Voltage: 6.0V
- $\pm 2\%$ Voltage Accuracy at $V_{OUT} > 1.5V$
 $\pm 30mV$ Voltage Accuracy at $V_{OUT} \leq 1.5V$
- Fast Transient Response
- Under Voltage Lockout
- Fixed Output Voltage of UM1650S-xx and UM1750S/Y/DA-xx from 1.0V to 4.0V with 0.1V Interval
- Adjustable Output Voltage of UM1750S/Y/DA-00 from 1.0V to 5.0V
- Output Current Limit
- Stable with 1 μ F Output Capacitor
- Short-Circuit and Thermal Overload Protection
- Low Profile SOT23-3, SOT23-5, SOT89-5 and DFN6 2.0×2.0 Packages

Pin Configurations

Top View

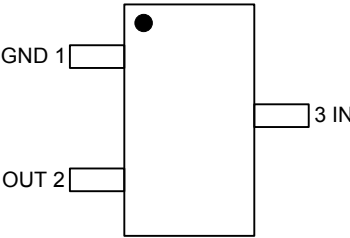
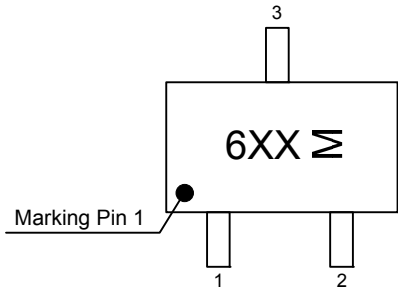
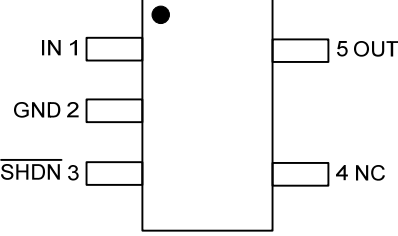
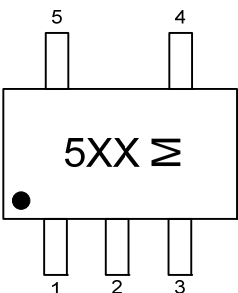
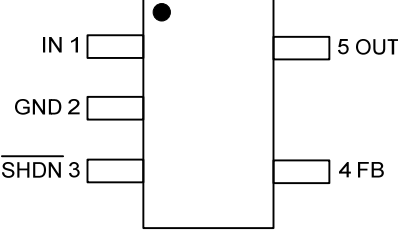
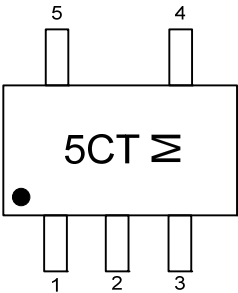
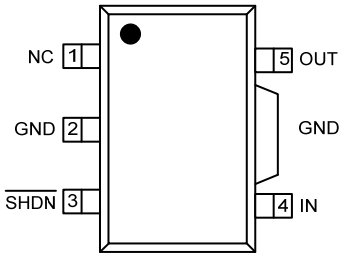
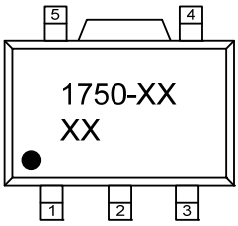
	 <p>M: Month Code UM1650S-xx SOT23-3</p>
	 <p>M: Month Code UM1750S-xx SOT23-5</p>
	 <p>M: Month Code UM1750S-00 SOT23-5</p>
	 <p>XX: Week Code UM1750Y-xx SOT89-5</p>

Pin Configurations (Continued)

Top View

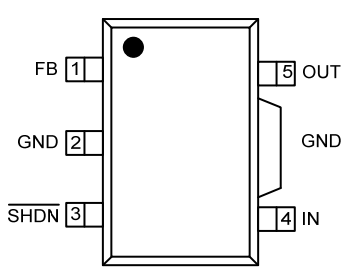
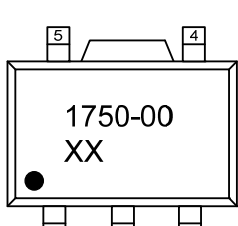
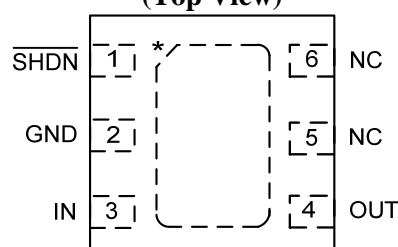
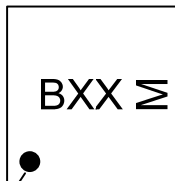
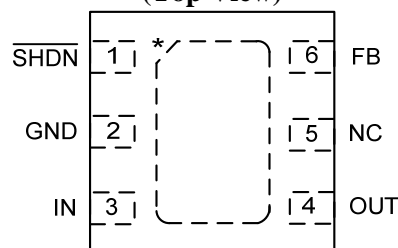
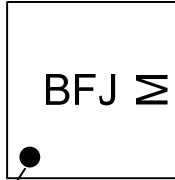
	 <p>XX: Week Code UM1750Y-00 SOT89-5</p>
<p>(Top View)</p> 	 <p>M: Month Code UM1750DA-xx DFN6 2.0x2.0</p>
<p>(Top View)</p> 	 <p>M: Month Code UM1750DA-00 DFN6 2.0x2.0</p>

* The tab on the bottom of the package enhances thermal performance and is electrically connected to GND (substrate level). It is recommended that the tab be connected to the ground plane on the board. If not, the tab can be left open.

Pin Description

Pin Number			Symbol	Function
UM1650S-xx	UM1750S-xx (Fixed V _{OUT})	UM1750S-00 (Adjustable V _{OUT})		
3	1	1	IN	Power Supply
1	2	2	GND	Ground
-	3	3	SHDN	Shutdown Input: High=Activate LDO, Low=Shutdown LDO
-	4	-	NC	Not Connected
2	5	5	OUT	Voltage Regulated Output
-	-	4	FB	Output Voltage Feedback

Pin Description (Continued)

Pin Number				Symbol	Function
UM1750Y-xx (Fixed V _{OUT})	UM1750Y-00 (Adjustable V _{OUT})	UM1750DA-xx (Fixed V _{OUT})	UM1750DA-00 (Adjustable V _{OUT})		
4	4	3	3	IN	Power Supply
2	2	2	2	GND	Ground
3	3	1	1	$\overline{\text{SHDN}}$	Shutdown Input: High=Activate LDO, Low=Shutdown LDO
1	-	5,6	5	NC	Not Connected
5	5	4	4	OUT	Voltage Regulated Output
-	1	-	6	FB	Output Voltage Feedback

Naming Information

UM1650/1750 □ □ - □ □

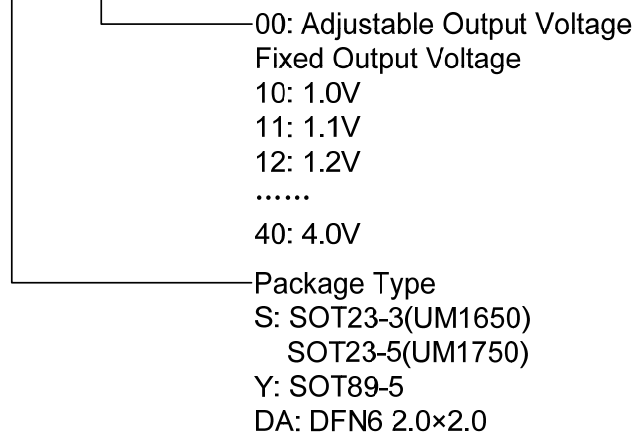

Ordering Information

Part Number	Output Voltage	Packaging Type	Marking Code	Shipping Qty
UM1650S-10	1.0V	SOT23-3	6AA	3000pcs/7Inch Tape & Reel
UM1650S-11	1.1V		6AB	
UM1650S-12	1.2V		6A2	
UM1650S-13	1.3V		6A3	
UM1650S-14	1.4V		6A4	
UM1650S-15	1.5V		6A5	
UM1650S-16	1.6V		6A6	
UM1650S-17	1.7V		6A7	
UM1650S-18	1.8V		6A8	
UM1650S-19	1.9V		6A9	
UM1650S-20	2.0V		6BA	
UM1650S-21	2.1V		6BB	
UM1650S-22	2.2V		6B2	
UM1650S-23	2.3V		6B3	
UM1650S-24	2.4V		6B4	
UM1650S-25	2.5V		6B5	
UM1650S-26	2.6V		6B6	
UM1650S-27	2.7V		6B7	
UM1650S-28	2.8V		6B8	
UM1650S-29	2.9V		6B9	
UM1650S-30	3.0V		6CA	
UM1650S-31	3.1V		6CB	
UM1650S-32	3.2V		6C2	
UM1650S-33	3.3V		6C3	
UM1650S-34	3.4V		6C4	
UM1650S-35	3.5V		6C5	
UM1650S-36	3.6V		6C6	
UM1650S-37	3.7V		6C7	
UM1650S-38	3.8V		6C8	
UM1650S-39	3.9V		6C9	
UM1650S-40	4.0V		6CC	

Ordering Information (Continued)

Part Number	Output Voltage	Packaging Type	Marking Code	Shipping Qty
UM1750S-00	ADJ	SOT23-5	5CT	3000pcs/7Inch Tape & Reel
UM1750S-10	1.0V		5JA	
UM1750S-11	1.1V		5JB	
UM1750S-12	1.2V		5J2	
UM1750S-13	1.3V		5J3	
UM1750S-14	1.4V		5J4	
UM1750S-15	1.5V		5J5	
UM1750S-16	1.6V		5J6	
UM1750S-17	1.7V		5J7	
UM1750S-18	1.8V		5J8	
UM1750S-19	1.9V		5J9	
UM1750S-20	2.0V		5NA	
UM1750S-21	2.1V		5NB	
UM1750S-22	2.2V		5N2	
UM1750S-23	2.3V		5N3	
UM1750S-24	2.4V		5N4	
UM1750S-25	2.5V		5N5	
UM1750S-26	2.6V		5N6	
UM1750S-27	2.7V		5N7	
UM1750S-28	2.8V		5N8	
UM1750S-29	2.9V		5N9	
UM1750S-30	3.0V		5PA	
UM1750S-31	3.1V		5PB	
UM1750S-32	3.2V		5HP	
UM1750S-33	3.3V		5CU	
UM1750S-34	3.4V		5P4	
UM1750S-35	3.5V		5P5	
UM1750S-36	3.6V		5P6	
UM1750S-37	3.7V		5P7	
UM1750S-38	3.8V		5P8	
UM1750S-39	3.9V		5P9	
UM1750S-40	4.0V		5PC	

Ordering Information (Continued)

Part Number	Output Voltage	Packaging Type	Marking Code	Shipping Qty
UM1750Y-00	ADJ	SOT89-5	1750-00	1000pcs/7Inch Tape & Reel
UM1750Y-10	1.0V		1750-10	
UM1750Y-11	1.1V		1750-11	
UM1750Y-12	1.2V		1750-12	
UM1750Y-13	1.3V		1750-13	
UM1750Y-14	1.4V		1750-14	
UM1750Y-15	1.5V		1750-15	
UM1750Y-16	1.6V		1750-16	
UM1750Y-17	1.7V		1750-17	
UM1750Y-18	1.8V		1750-18	
UM1750Y-19	1.9V		1750-19	
UM1750Y-20	2.0V		1750-20	
UM1750Y-21	2.1V		1750-21	
UM1750Y-22	2.2V		1750-22	
UM1750Y-23	2.3V		1750-23	
UM1750Y-24	2.4V		1750-24	
UM1750Y-25	2.5V		1750-25	
UM1750Y-26	2.6V		1750-26	
UM1750Y-27	2.7V		1750-27	
UM1750Y-28	2.8V		1750-28	
UM1750Y-29	2.9V		1750-29	
UM1750Y-30	3.0V		1750-30	
UM1750Y-31	3.1V		1750-31	
UM1750Y-32	3.2V		1750-32	
UM1750Y-33	3.3V		1750-33	
UM1750Y-34	3.4V		1750-34	
UM1750Y-35	3.5V		1750-35	
UM1750Y-36	3.6V		1750-36	
UM1750Y-37	3.7V		1750-37	
UM1750Y-38	3.8V		1750-38	
UM1750Y-39	3.9V		1750-39	
UM1750Y-40	4.0V		1750-40	

Ordering Information (Continued)

Part Number	Output Voltage	Packaging Type	Marking Code	Shipping Qty
UM1750DA-00	ADJ	DFN6 2.0×2.0	BFJ	3000pcs/7Inch Tape & Reel
UM1750DA-10	1.0V		BFE	
UM1750DA-11	1.1V		BFF	
UM1750DA-12	1.2V		BH2	
UM1750DA-13	1.3V		BH3	
UM1750DA-14	1.4V		BH4	
UM1750DA-15	1.5V		BH5	
UM1750DA-16	1.6V		BH6	
UM1750DA-17	1.7V		BH7	
UM1750DA-18	1.8V		BH8	
UM1750DA-19	1.9V		BH9	
UM1750DA-20	2.0V		BHA	
UM1750DA-21	2.1V		BHB	
UM1750DA-22	2.2V		BJ2	
UM1750DA-23	2.3V		BJ3	
UM1750DA-24	2.4V		BJ4	
UM1750DA-25	2.5V		BJ5	
UM1750DA-26	2.6V		BJ6	
UM1750DA-27	2.7V		BJ7	
UM1750DA-28	2.8V		BJ8	
UM1750DA-29	2.9V		BJ9	
UM1750DA-30	3.0V		BJA	
UM1750DA-31	3.1V		BJB	
UM1750DA-32	3.2V		BK2	
UM1750DA-33	3.3V		BK3	
UM1750DA-34	3.4V		BK4	
UM1750DA-35	3.5V		BK5	
UM1750DA-36	3.6V		BK6	
UM1750DA-37	3.7V		BK7	
UM1750DA-38	3.8V		BK8	
UM1750DA-39	3.9V		BK9	
UM1750DA-40	4.0V		BKA	

Absolute Maximum Ratings (Note 1)

Symbol	Parameter	Value	Unit	
V_{IN}	Supply Voltage on IN Pin	-0.3 to +7.5	V	
$V_{\overline{SHDN}}$	Voltage on \overline{SHDN} Pin	-0.3 to +7.5	V	
V_{FB}	Voltage on FB Pin	-0.3 to +7.5	V	
V_{OUT}	Voltage on OUT Pin	-0.3 to +7.5	V	
	Output Short-Circuit Duration	Indefinite		
θ_{JA}	Junction Thermal Resistance (Note 2)	SOT23-3	+225	°C/W
		SOT23-5	+215	
		SOT89-5	+66	
		DFN6 2.0×2.0	+110	
T_J	Operating Junction Temperature (Note 3, 4)	-40 to +125	°C	
T_{STG}	Storage Temperature Range	-65 to +150	°C	
T_L	Lead Temperature for Soldering 10 Seconds	+300	°C	

Note 1: Absolute Maximum Ratings are those values beyond which the life of a device may be impaired.

Note 2: The maximum allowable power dissipation of any T_A (ambient temperature) is $P_{D(max)} = (T_{J(max)} - T_A) / \theta_{JA}$. Exceeding the maximum allowable power dissipation will result in excessive die temperature, and the regulator will go into thermal shutdown.

Note 3: The UM1650/UM1750 is tested and specified under pulse load conditions such that $T_J \approx T_A$. Specifications over the -40°C to 125°C operating junction temperature range are assured by design, characterization and correlation with statistical process controls.

Note 4: This IC includes overtemperature protection that is intended to protect the device during momentary overload conditions. Junction temperature will exceed 125°C when overtemperature protection is active. Continuous operation above the specified maximum operating junction temperature may impair device reliability.

Electrical Characteristics

$V_{\overline{\text{SHDN}}}=V_{\text{IN}}=V_{\text{OUT}}+1\text{V}$, $C_{\text{IN}}=C_{\text{OUT}}=1.0\mu\text{F}$, $T_{\text{A}}=25^{\circ}\text{C}$, unless noted.

Symbol	Parameter	Test Conditions	Min	Typ	Max	Unit	
V_{IN}	Input Voltage Range		2.5		6.0	V	
V_{UVLO}	Input Under Voltage Lockout	V_{IN} Falling	1.8		2.4	V	
I_{Q}	Operating Quiescent Current	$V_{\text{IN}}=4.3\text{V}$, $I_{\text{OUT}}=0\text{mA}$		90	130	μA	
		$V_{\text{IN}}=4.3\text{V}$, $I_{\text{OUT}}=350\text{mA}$		190	300		
$I_{\overline{\text{SHDN}}}$	Shutdown Leakage Current				1	μA	
I_{OUT}	Output Current		350			mA	
V_{FB}	Feedback Reference Voltage	$V_{\text{IN}}=2.5\text{V}$ to 6.0V	0.98	1.00	1.02	V	
	Output Voltage Accuracy	$0\text{mA} \leq I_{\text{OUT}} \leq 350\text{mA}$	$V_{\text{OUT}} > 1.5\text{V}$	-2		+2	%
			$V_{\text{OUT}} \leq 1.5\text{V}$	-30		+30	mV
ΔV_{DO} (Note 5)	Dropout Voltage	$I_{\text{OUT}}=150\text{mA}$		110	150	mV	
I_{LIMIT}	Output Current Limit	$V_{\text{IN}} \geq 2.5\text{V}$	550			mA	
t	Startup Time Response	$R_{\text{L}}=68\Omega$, $C_{\text{OUT}}=1\mu\text{F}$		44		μs	
V_{IL}	$\overline{\text{SHDN}}$ Input Low Voltage	$V_{\text{IN}}=6.0\text{V}$			0.4	V	
V_{IH}	$\overline{\text{SHDN}}$ Input High Voltage	$V_{\text{IN}}=6.0\text{V}$	2.0			V	
	$\overline{\text{SHDN}}$ Input Current	$\overline{\text{SHDN}}=V_{\text{IN}}$ or GND	-1		+1	μA	
T_{SHDN}	Thermal-Shutdown Temperature			160		$^{\circ}\text{C}$	
ΔT_{SHDN}	Thermal-Shutdown Hysteresis			20		$^{\circ}\text{C}$	
	Line Regulation	$V_{\text{OUT}}+1\text{V} \leq V_{\text{IN}} \leq V_{\text{OUT}}+2\text{V}$, $V_{\text{IN}} \geq 2.5\text{V}$ $I_{\text{OUT}}=10\text{mA}$		0.09		%/V	
	Load Regulation	$V_{\text{IN}}=V_{\text{OUT}}+1\text{V}$, $V_{\text{IN}} \geq 2.5\text{V}$ $1\text{mA} \leq I_{\text{OUT}} \leq 150\text{mA}$		0.2		%	
	Output Voltage Noise	10Hz to 100kHz $C_{\text{IN}}=1\mu\text{F}$, $V_{\text{OUT}}=3.3\text{V}$, $I_{\text{OUT}}=150\text{mA}$		195		μV_{RMS}	
PSRR	Power Supply Ripple Rejection	$V_{\text{IN}}=V_{\text{OUT}}+1\text{V}$ $I_{\text{OUT}}=100\text{mA}$	f=100Hz		63		dB
			f=1kHz		55		
			f=10kHz		40		

Note 5: ΔV_{DO} just defined for device with $V_{\text{OUT}} \geq 2.5\text{V}$.

Typical Application Circuit

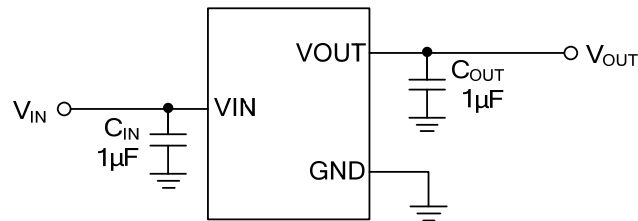

Figure 1. UM1650S-xx Typical Application Circuit

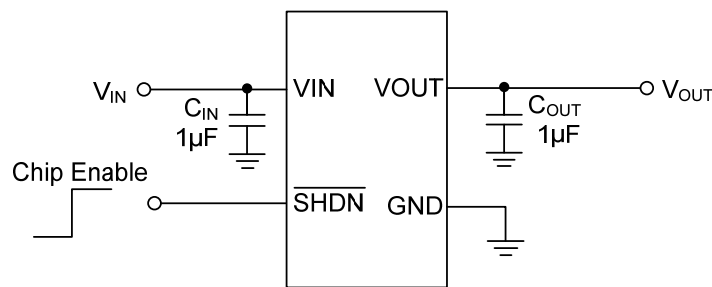

Figure 2. UM1750S-xx/UM1750Y-xx/UM1750DA-xx (Fixed V_{OUT}) Typical Application Circuit

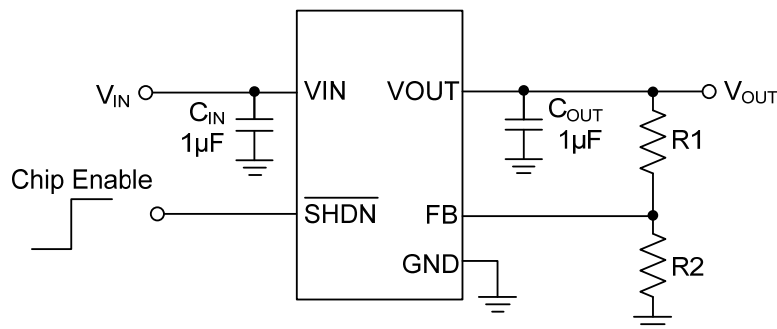

Figure 3. UM1750S-00/UM1750Y-00/UM1750DA-00 (Adjustable V_{OUT}) Typical Application Circuit

UM1750S-00/UM1750Y-00/UM1750DA-00 Output Voltage Setting

The output voltage of the UM1750 adjustable regulator is programmed using an external resistor divider as shown in Figure 3. The output voltage is calculated using:

$$V_{OUT} = V_{FB} \left(1 + \frac{R1}{R2} \right)$$

Where: $V_{FB}=1.00V$ (Typ) (the internal reference voltage)

Resistors R1 and R2 should be chosen for approximately 3-5µA divider current. Lower value resistors can be used but offer no inherent advantage and waste more power. Higher values should be avoided, as leakage currents at FB increase the output voltage error. The recommended design procedure is to choose $R2=200k\Omega$ to set the divider current at 5µA and then calculate R1 using:

$$R1 = \left(\frac{V_{OUT}}{V_{FB}} - 1 \right) \times R2$$

Where: $V_{FB}=1.00V$ (Typ).

Typical Performance Characteristics (Shown for 3.3V Output Option)

Quiescent Current vs. Input Voltage

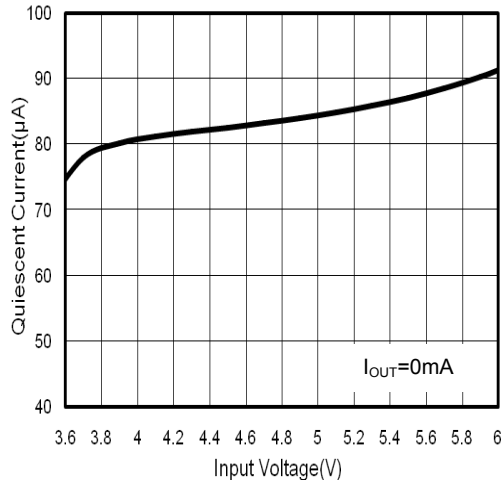

Quiescent Current vs. Temperature

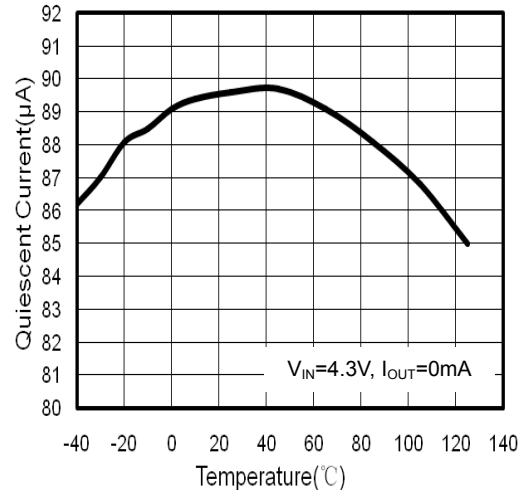

GND Current vs. Output Current

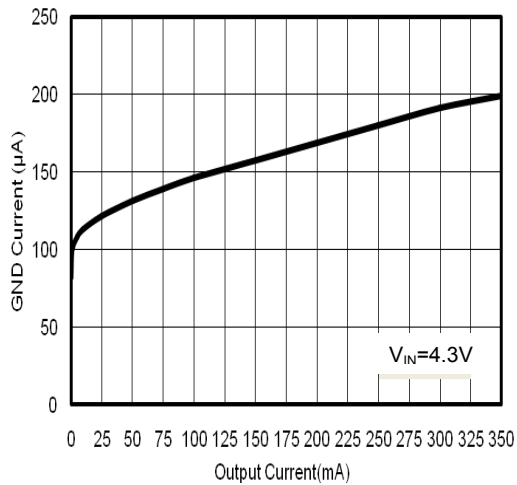

Output Voltage vs. Input Voltage

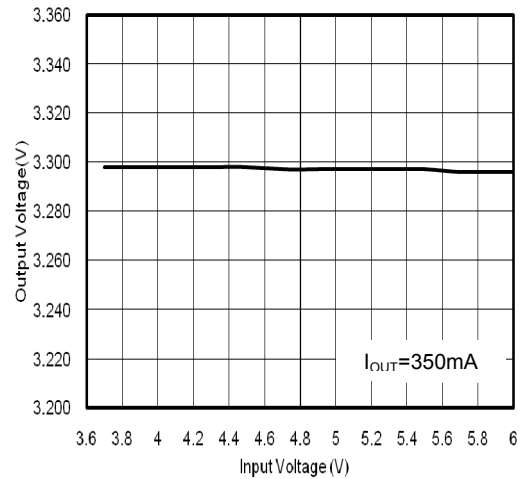

Output Voltage vs. Output Current

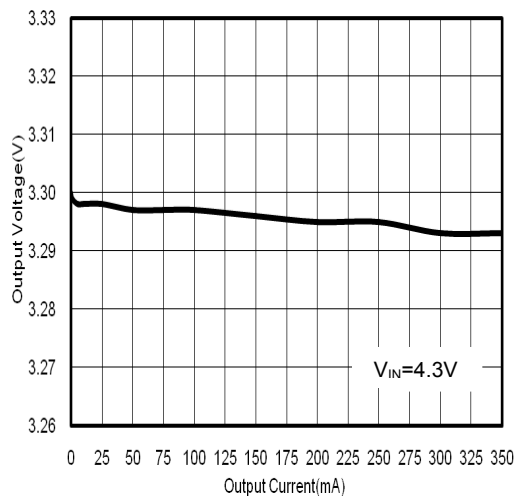

Output Voltage vs. Temperature

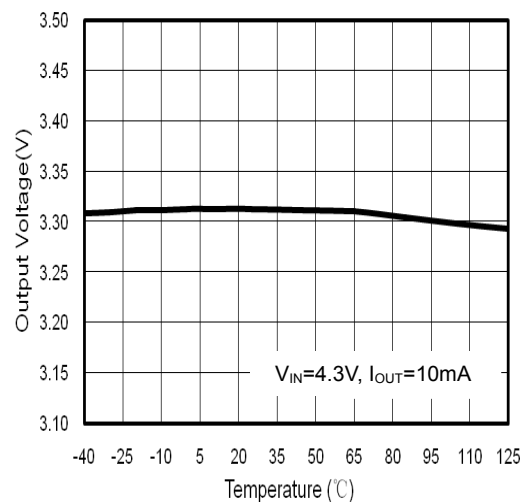

Typical Performance Characteristics (Continued)

(Shown for 3.3V Output Option)

Dropout Voltage vs. Output Current

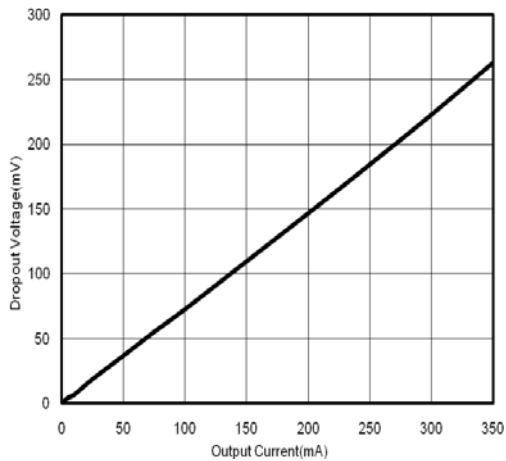

PSRR vs. Frequency

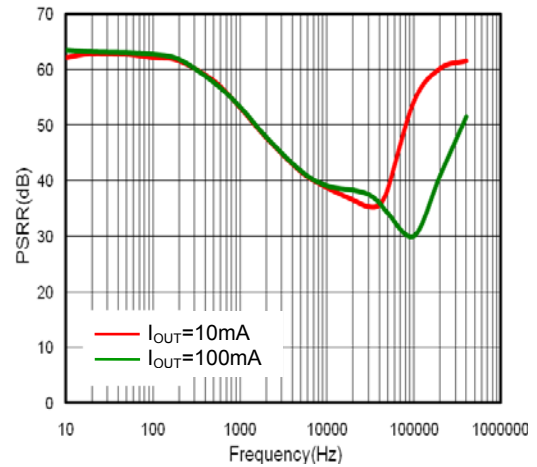

Noise

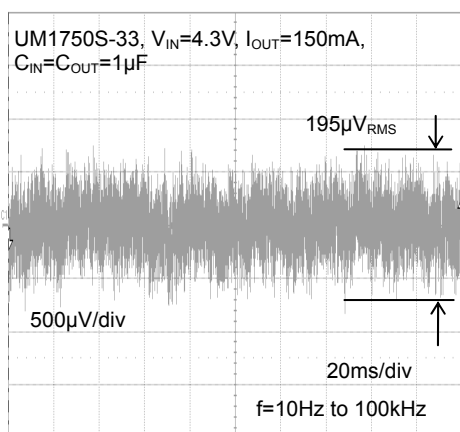

Load Transient Response

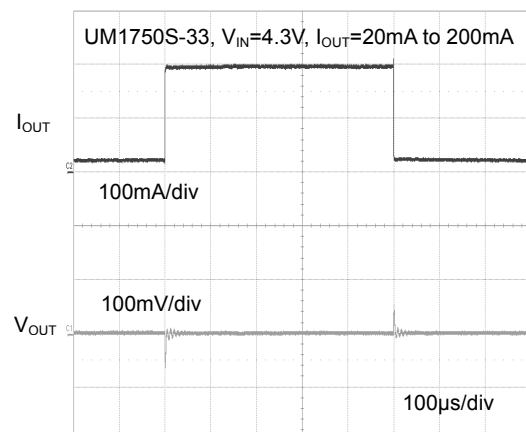

Line Transient Response

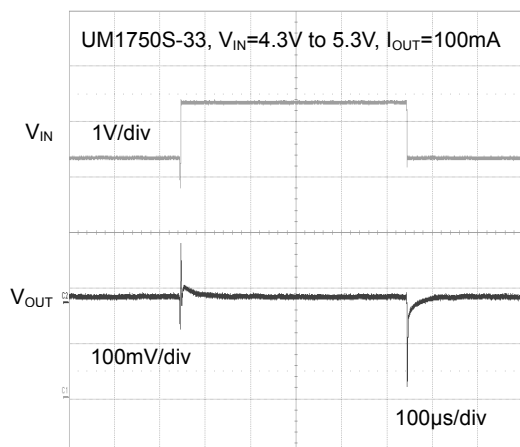

Startup Waveform

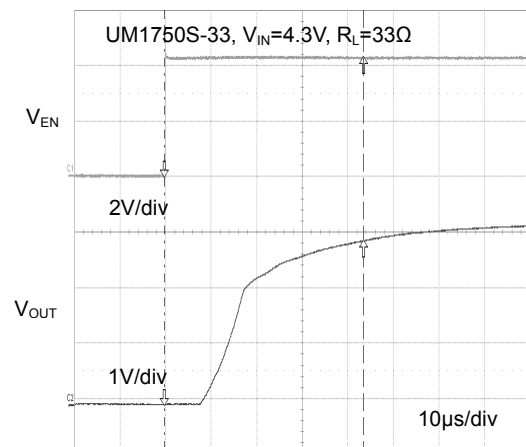

Package Information

UM1650S-xx: SOT23-3

Outline Drawing

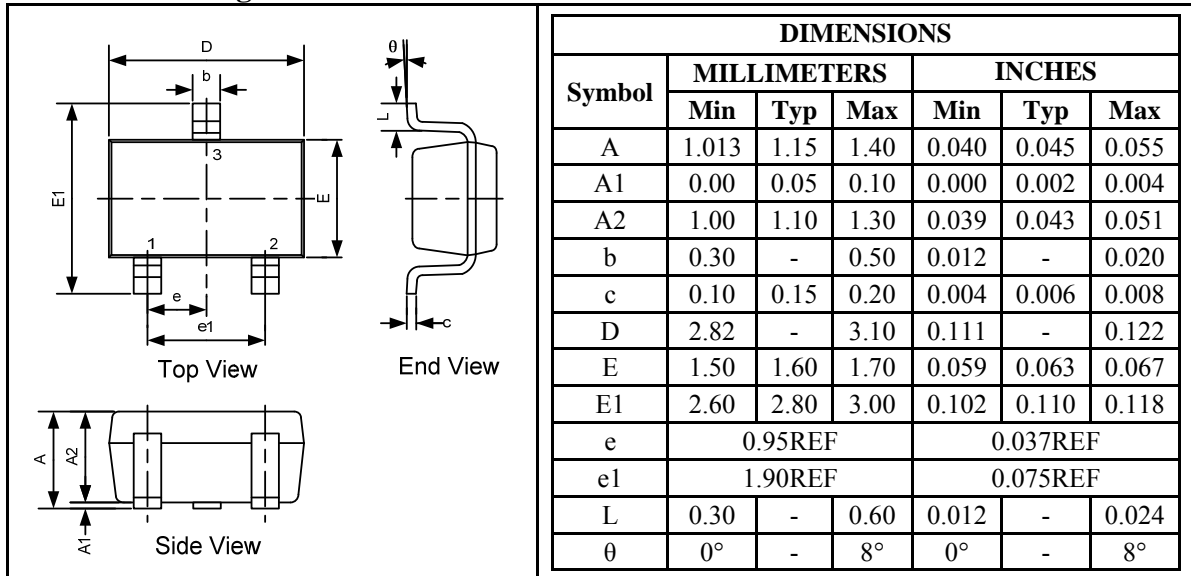

Land Pattern

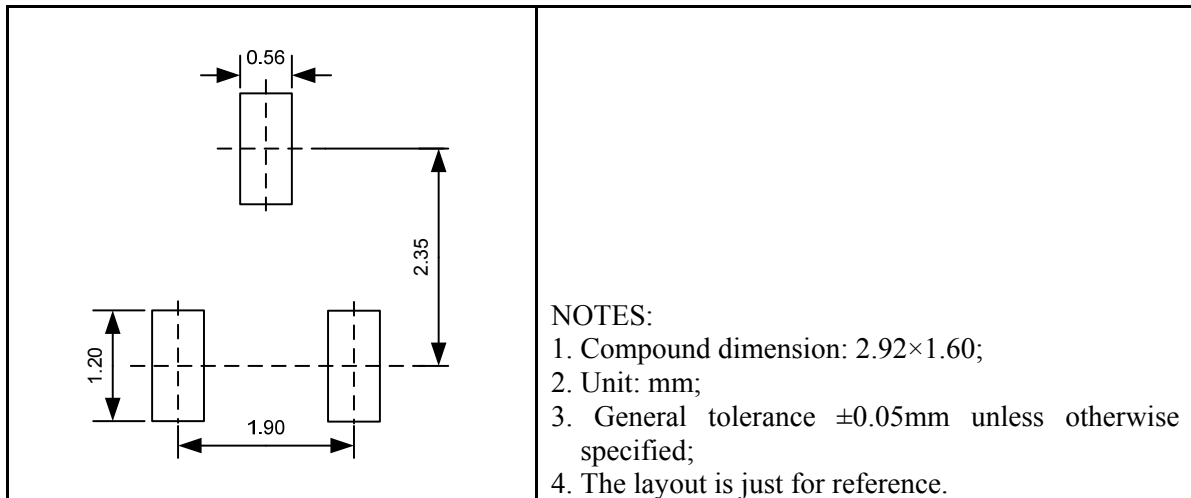

Tape and Reel Orientation



UM1750S-xx: SOT23-5

Outline Drawing

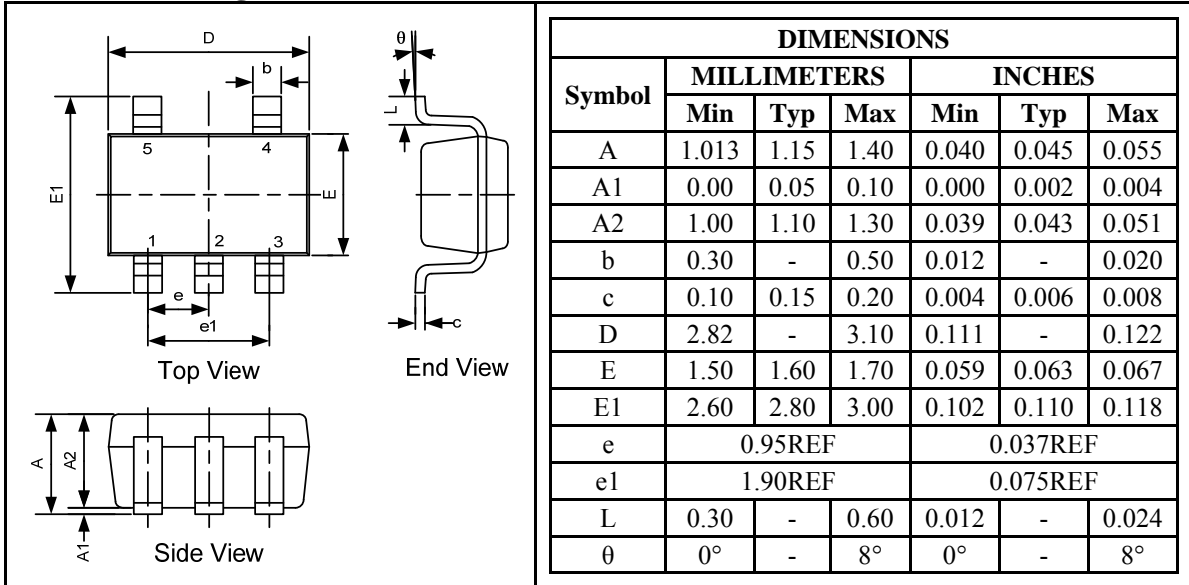

Land Pattern

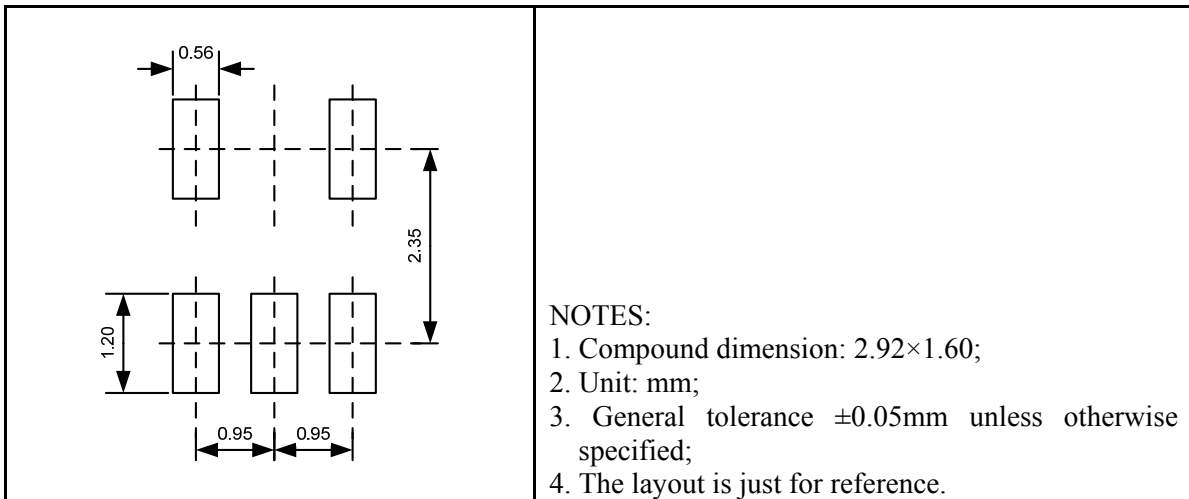

Tape and Reel Orientation



UM1750Y-xx: SOT89-5

Outline Drawing

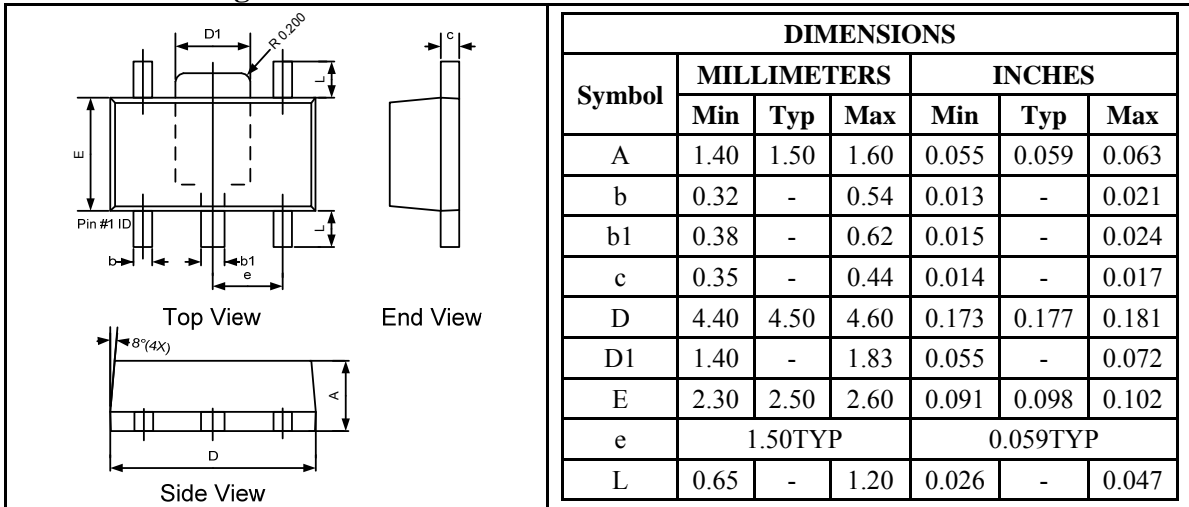

Land Pattern

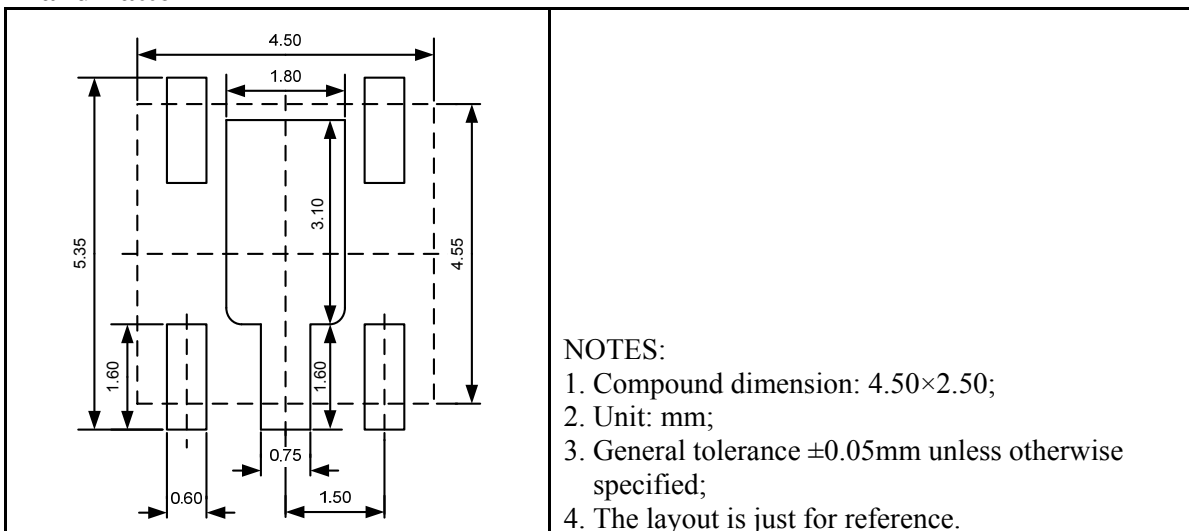

Tape and Reel Orientation



UM1750DA-xx: DFN6 2.0×2.0

Outline Drawing

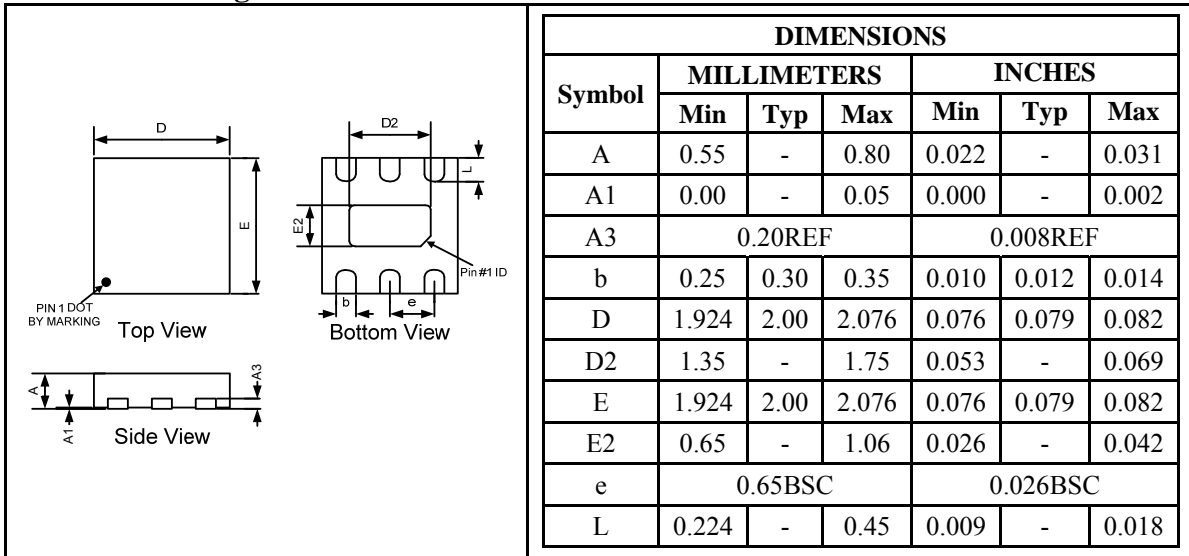

Land Pattern

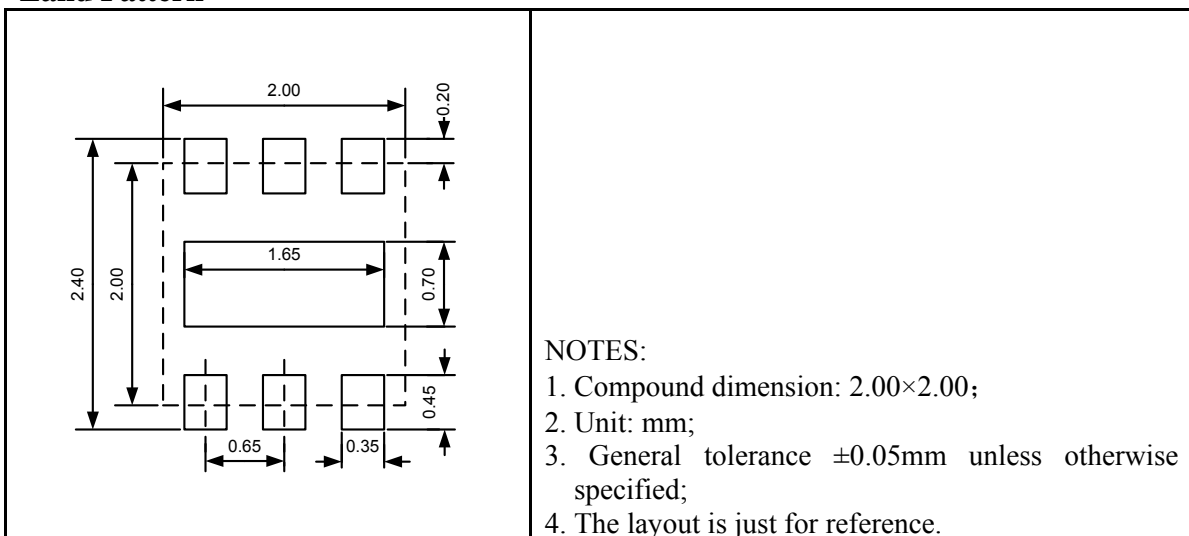

Tape and Reel Orientation



GREEN COMPLIANCE

Union Semiconductor is committed to environmental excellence in all aspects of its operations including meeting or exceeding regulatory requirements with respect to the use of hazardous substances. Numerous successful programs have been implemented to reduce the use of hazardous substances and/or emissions.

All Union components are compliant with the RoHS directive, which helps to support customers in their compliance with environmental directives. For more green compliance information, please visit:



http://www.union-ic.com/index.aspx?cat_code=RoHSDeclaration

IMPORTANT NOTICE

The information in this document has been carefully reviewed and is believed to be accurate. Nonetheless, this document is subject to change without notice. Union assumes no responsibility for any inaccuracies that may be contained in this document, and makes no commitment to update or to keep current the contained information, or to notify a person or organization of any update. Union reserves the right to make changes, at any time, in order to improve reliability, function or design and to attempt to supply the best product possible.

Looking for pricing, stock, or lifecycle information?

Click below to explore more details on WIN SOURCE:

-  [View UM1750S-00 on WIN SOURCE](#)
-  [Union Semiconductor](#) Information

Optimize Your Supply Chain with WIN SOURCE Solutions

-  Global Sourcing Solution
-  Obsolete Management
-  Cost Control Management
-  Shortage Management
-  Alternative Solution
-  Excess Inventory Management