



# THE DATASHEET OF SN74F299DWR



# SN54F299, SN74F299

## 8-BIT UNIVERSAL SHIFT/STORAGE REGISTERS WITH 3-STATE OUTPUTS

SDFS071B – MARCH 1987 – REVISED APRIL 2004

The SN54F299 is obsolete and no longer supplied.

- **Four Modes of Operation:**
  - Hold (Store)
  - Shift Right
  - Shift Left
  - Load Data
- **Operates With Outputs Enabled or at High Impedance**
- **3-State Outputs Drive Bus Lines Directly**
- **Can Be Cascaded for N-Bit Word Lengths**
- **Direct Overriding Clear**
- **Applications:**
  - Stacked or Pushdown Registers
  - Buffer Storage
  - Accumulator Registers

### description/ordering information

These 8-bit universal shift/storage registers feature multiplexed I/O ports to achieve full 8-bit data handling in a single 20-pin package. Two function-select ( $S_0, S_1$ ) inputs and two output-enable ( $\overline{OE}1, \overline{OE}2$ ) inputs can be used to choose the modes of operation listed in the function table.

Synchronous parallel loading is accomplished by taking both  $S_0$  and  $S_1$  high. This places the 3-state outputs in a high-impedance state and permits data that is applied on the I/O ports to be clocked into the register. Reading out of the register can be accomplished while the outputs are enabled in any mode. Clearing occurs when the clear ( $\overline{CLR}$ ) input is low. Taking either  $\overline{OE}1$  or  $\overline{OE}2$  high disables the outputs but has no effect on clearing, shifting, or storage of data.

SN54F299 . . . J PACKAGE  
SN74F299 . . . DW, N, OR NS PACKAGE  
(TOP VIEW)

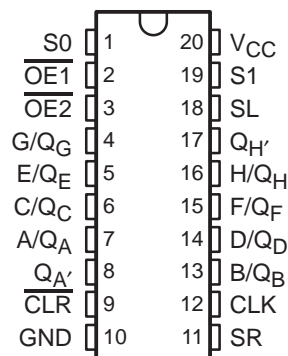

SN54F299 . . . FK PACKAGE  
(TOP VIEW)

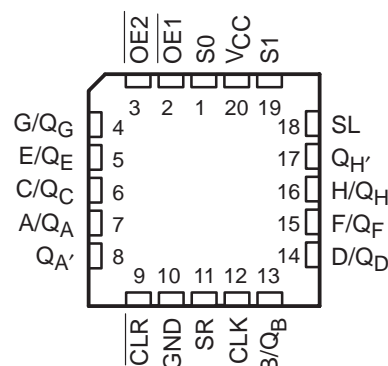

### ORDERING INFORMATION

T <sub>A</sub>	PACKAGE†		ORDERABLE PART NUMBER	TOP-SIDE MARKING
0°C to 70°C	PDIP – N	Tube of 20	SN74F299N	SN74F299N
	SOIC – DW	Tube of 25	SN74F299DW	F299
		Reel of 2000	SN74F299DWR	
	SOP – NS	Reel of 2000	SN74F299NSR	74F299

† Package drawings, standard packing quantities, thermal data, symbolization, and PCB design guidelines are available at [www.ti.com/sc/package](http://www.ti.com/sc/package).



Please be aware that an important notice concerning availability, standard warranty, and use in critical applications of Texas Instruments semiconductor products and disclaimers thereto appears at the end of this data sheet.

PRODUCTION DATA information is current as of publication date. Products conform to specifications per the terms of Texas Instruments standard warranty. Production processing does not necessarily include testing of all parameters.



POST OFFICE BOX 655303 • DALLAS, TEXAS 75265

Copyright © 2004, Texas Instruments Incorporated

# SN54F299, SN74F299

## 8-BIT UNIVERSAL SHIFT/STORAGE REGISTERS

### WITH 3-STATE OUTPUTS

SDFS071B – MARCH 1987 – REVISED APRIL 2004

The SN54F299 is obsolete and no longer supplied.

FUNCTION TABLE

MODE	INPUTS								I/O PORTS								OUTPUTS	
	CLR	S1	S0	OE1†	OE2†	CLK	SL	SR	A/Q <sub>A</sub>	B/Q <sub>B</sub>	C/Q <sub>C</sub>	D/Q <sub>D</sub>	E/Q <sub>E</sub>	F/Q <sub>F</sub>	G/Q <sub>G</sub>	H/Q <sub>H</sub>	Q <sub>A</sub> '	Q <sub>H</sub> '
Clear	L	X	L	L	L	X	X	X	L	L	L	L	L	L	L	L	L	L
	L	L	X	L	L	X	X	X	L	L	L	L	L	L	L	L	L	L
	L	H	H	X	X	X	X	X	X	X	X	X	X	X	X	X	L	L
Hold	H	L	L	L	L	X	X	X	Q <sub>A0</sub>	Q <sub>B0</sub>	Q <sub>C0</sub>	Q <sub>D0</sub>	Q <sub>E0</sub>	Q <sub>F0</sub>	Q <sub>G0</sub>	Q <sub>H0</sub>	Q <sub>A0</sub>	Q <sub>H0</sub>
	H	X	X	L	L	L	X	X	Q <sub>A0</sub>	Q <sub>B0</sub>	Q <sub>C0</sub>	Q <sub>D0</sub>	Q <sub>E0</sub>	Q <sub>F0</sub>	Q <sub>G0</sub>	Q <sub>H0</sub>	Q <sub>A0</sub>	Q <sub>H0</sub>
Shift Right	H	L	H	L	L	↑	X	H	H	Q <sub>An</sub>	Q <sub>Bn</sub>	Q <sub>Cn</sub>	Q <sub>Dn</sub>	Q <sub>En</sub>	Q <sub>Fn</sub>	Q <sub>Gn</sub>	H	Q <sub>Gn</sub>
	H	L	H	L	L	↑	X	L	L	Q <sub>An</sub>	Q <sub>Bn</sub>	Q <sub>Cn</sub>	Q <sub>Dn</sub>	Q <sub>En</sub>	Q <sub>Fn</sub>	Q <sub>Gn</sub>	L	Q <sub>Gn</sub>
Shift Left	H	H	L	L	L	↑	H	X	Q <sub>Bn</sub>	Q <sub>Cn</sub>	Q <sub>Dn</sub>	Q <sub>En</sub>	Q <sub>Fn</sub>	Q <sub>Gn</sub>	Q <sub>Hn</sub>	H	Q <sub>Bn</sub>	H
	H	H	L	L	L	↑	L	X	Q <sub>Bn</sub>	Q <sub>Cn</sub>	Q <sub>Dn</sub>	Q <sub>En</sub>	Q <sub>Fn</sub>	Q <sub>Gn</sub>	Q <sub>Hn</sub>	L	Q <sub>Bn</sub>	L
Load	H	H	H	X	X	↑	X	X	a	b	c	d	e	f	g	h	a	h

NOTE: a . . . h = the level of the steady-state input at inputs A through H, respectively. This data is loaded into the flip-flops while the flip-flop outputs are isolated from the I/O terminals.

† When one or both output-enable inputs are high, the eight I/O terminals are disabled to the high-impedance state; however, sequential operation or clearing of the register is not affected.

### logic diagram (positive logic)

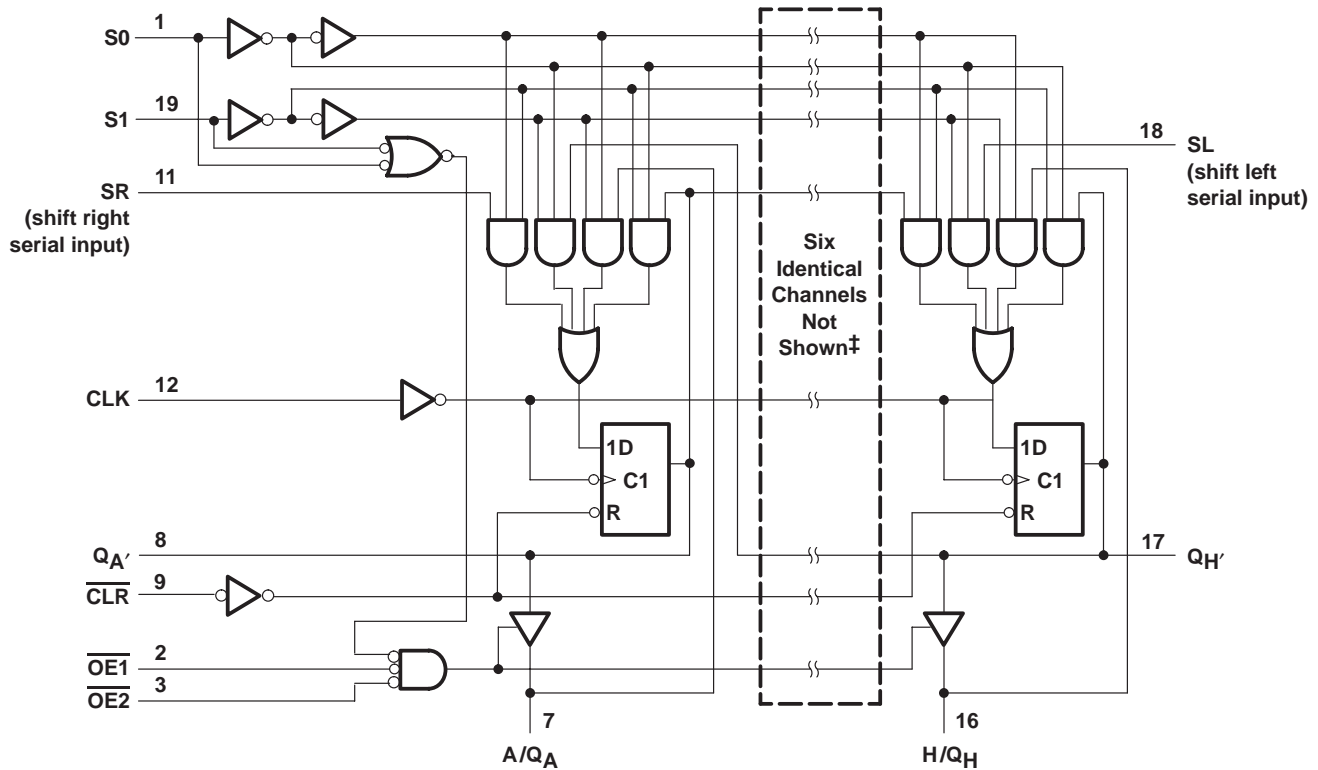

‡ I/O ports not shown: B/Q<sub>B</sub> (13), C/Q<sub>C</sub> (6), D/Q<sub>D</sub> (14), E/Q<sub>E</sub> (5), F/Q<sub>F</sub> (15), and G/Q<sub>G</sub> (4).

The SN54F299 is obsolete and no longer supplied.

# SN54F299, SN74F299 8-BIT UNIVERSAL SHIFT/STORAGE REGISTERS WITH 3-STATE OUTPUTS

SDFS071B – MARCH 1987 – REVISED APRIL 2004

## absolute maximum ratings over operating free-air temperature range (unless otherwise noted)†

Supply voltage range, $V_{CC}$ .....	–0.5 V to 7 V
Input voltage range, $V_I$ (see Note 1) .....	–1.2 V to 7 V
Input current range .....	–30 mA to 5 mA
Voltage range applied to any output in the disabled or power-off state .....	–0.5 V to 5.5 V
Voltage range applied to any output in the high state .....	–0.5 V to $V_{CC}$
Current into any output in the low state: $Q_{A'}$ or $Q_{H'}$ .....	40 mA
SN54F299 ( $Q_A$ thru $Q_H$ ) .....	40 mA
SN74F299 ( $Q_A$ thru $Q_H$ ) .....	48 mA
Package thermal impedance, $\theta_{JA}$ (see Note 2): DW package .....	58°C/W
N package .....	69°C/W
NS package .....	60°C/W
Storage temperature range, $T_{stg}$ .....	–65°C to 150°C

† Stresses beyond those listed under “absolute maximum ratings” may cause permanent damage to the device. These are stress ratings only, and functional operation of the device at these or any other conditions beyond those indicated under “recommended operating conditions” is not implied. Exposure to absolute-maximum-rated conditions for extended periods may affect device reliability.

- NOTES: 1. The input voltage ratings may be exceeded provided the input current ratings are observed.  
 2. The package thermal impedance is calculated in accordance with JESD 51-7.

## recommended operating conditions (see Note 3)

		SN54F299			SN74F299			UNIT
		MIN	NOM	MAX	MIN	NOM	MAX	
$V_{CC}$	Supply voltage	4.5	5	5.5	4.5	5	5.5	V
$V_{IH}$	High-level input voltage	2			2			V
$V_{IL}$	Low-level input voltage			0.8			0.8	V
$I_{IK}$	Input clamp current			–18			–18	mA
$I_{OH}$	High-level output current	$Q_{A'}$ or $Q_{H'}$		–1	$Q_{A'}$ or $Q_{H'}$		–1	mA
		$Q_A$ thru $Q_H$		–3	$Q_A$ thru $Q_H$		–3	
$I_{OL}$	Low-level output current	$Q_{A'}$ or $Q_{H'}$		20	$Q_{A'}$ or $Q_{H'}$		20	mA
		$Q_A$ thru $Q_H$		20	$Q_A$ thru $Q_H$		24	
$T_A$	Operating free-air temperature	–55		125	0		70	°C

NOTE 3: All unused inputs of the device must be held at  $V_{CC}$  or GND to ensure proper device operation. Refer to the TI application report, *Implications of Slow or Floating CMOS Inputs*, literature number SCBA004.



# SN54F299, SN74F299

## 8-BIT UNIVERSAL SHIFT/STORAGE REGISTERS

### WITH 3-STATE OUTPUTS

SDFS071B – MARCH 1987 – REVISED APRIL 2004

The SN54F299 is obsolete and no longer supplied.

electrical characteristics over recommended operating free-air temperature range (unless otherwise noted)

PARAMETER		TEST CONDITIONS		SN54F299			SN74F299			UNIT
				MIN	TYP†	MAX	MIN	TYP†	MAX	
$V_{IK}$		$V_{CC} = 4.5\text{ V}$ , $I_I = -18\text{ mA}$		-1.2			-1.2			V
$V_{OH}$	$Q_A'$ or $Q_H'$	$V_{CC} = 4.5\text{ V}$	$I_{OH} = -1\text{ mA}$	2.5	3.4		2.5	3.4	V	
	$Q_A$ thru $Q_H$		$I_{OH} = -1\text{ mA}$	2.5	3.4		2.5	3.4		
			$I_{OH} = -3\text{ mA}$	2.4	3.3		2.4	3.3		
Any output		$V_{CC} = 4.75\text{ V}$ ,	$I_{OH} = -1\text{ mA to } -3\text{ mA}$				2.7			
$V_{OL}$	$Q_A'$ or $Q_H'$	$V_{CC} = 4.5\text{ V}$	$I_{OL} = 20\text{ mA}$	0.3		0.5	0.3		0.5	V
	$Q_A$ thru $Q_H$		$I_{OL} = 20\text{ mA}$	0.3		0.5				
			$I_{OL} = 24\text{ mA}$				0.35	0.5		
$I_I$	A thru H	$V_{CC} = 5.5\text{ V}$	$V_I = 5.5\text{ V}$	1			1			mA
	Any other		$V_I = 7\text{ V}$	0.1			0.1			
$I_{IH}^\ddagger$	A thru H	$V_{CC} = 5.5\text{ V}$ ,	$V_I = 2.7\text{ V}$	70			70			$\mu\text{A}$
	Any other			20			20			
$I_{IL}^\ddagger$	A thru H	$V_{CC} = 5.5\text{ V}$ ,	$V_I = 0.5\text{ V}$	-0.65			-0.65			mA
	S0 or S1			-1.2			-1.2			
	Any other			-0.6			-0.6			
$I_{OS}^\S$		$V_{CC} = 5.5\text{ V}$ ,	$V_O = 0$	-60		-150	-60		-150	mA
$I_{CC}$		$V_{CC} = 5.5\text{ V}$ ,	See Note 4	68		95	68		95	mA

† All typical values are at  $V_{CC} = 5\text{ V}$ ,  $T_A = 25^\circ\text{C}$ .

‡ For I/O ports ( $Q_A$  thru  $Q_H$ ), the parameters  $I_{IH}$  and  $I_{IL}$  include the off-state output current.

§ Not more than one output should be shorted at a time, and the duration of the short circuit should not exceed one second.

NOTE 4:  $I_{CC}$  is measured with  $\overline{OE1}$ ,  $\overline{OE2}$ , and CLK at 4.5 V.

timing requirements over recommended ranges of supply voltage and operating free-air temperature (unless otherwise noted)

				$V_{CC} = 5\text{ V}$ , $T_A = 25^\circ\text{C}$		SN54F299		SN74F299		UNIT	
				'F299							
				MIN	MAX	MIN	MAX	MIN	MAX		
$f_{\text{clock}}$	Clock frequency			70		65		70		MHz	
$t_w$	Pulse duration		CLK high or low		7		8		7		ns
			$\overline{\text{CLR}}$ low		7		8		7		
$t_{su}$	Setup time before CLK $\uparrow$		S0 or S1	High or low	8.5		9.5		8.5		ns
			A/ $Q_A$ thru H/ $Q_H$ , SR, or SL	High or low	5.5		6.5		5.5		
	Inactive-state setup time before CLK $\uparrow$ $\uparrow$		$\overline{\text{CLR}}$	High	7		13		7		
$t_h$	Hold time after CLK $\uparrow$		S0 or S1	High or low	0		0		0		ns
			A/ $Q_A$ thru H/ $Q_H$ , SR, or SL	High or low	2		2		2		

$\uparrow$  Inactive-state setup time also is referred to as recovery time.



The SN54F299 is obsolete and no longer supplied.

# SN54F299, SN74F299 8-BIT UNIVERSAL SHIFT/STORAGE REGISTERS WITH 3-STATE OUTPUTS

SDFS071B – MARCH 1987 – REVISED APRIL 2004

## switching characteristics (see Figure 1)

PARAMETER	FROM (INPUT)	TO (OUTPUT)	V <sub>CC</sub> = 5 V, C <sub>L</sub> = 50 pF, R <sub>L</sub> = 500 Ω, T <sub>A</sub> = 25°C			V <sub>CC</sub> = 4.5 V to 5.5 V, C <sub>L</sub> = 50 pF, R <sub>L</sub> = 500 Ω, T <sub>A</sub> = MIN to MAX†				UNIT
			'F299			SN54F299		SN74F299		
			MIN	TYP	MAX	MIN	MAX	MIN	MAX	
f <sub>max</sub>			70	100		65		70	MHz	
t <sub>PLH</sub>	CLK	Q <sub>A</sub> ' or Q <sub>H</sub> '	3.2	6.6	9	2.7	10.5	3.2	10	ns
t <sub>PHL</sub>			2.7	6.1	8.5	2.2	10	2.7	9.5	
t <sub>PLH</sub>	CLK	Q <sub>A</sub> thru Q <sub>H</sub>	3.2	6.6	9	2.7	11	3.2	10	ns
t <sub>PHL</sub>			4.2	8.1	11	3.7	12.5	4.2	12	
t <sub>PHL</sub>	$\overline{\text{CLR}}$	Q <sub>A</sub> ' or Q <sub>H</sub> '	3.7	7.1	9.5	3.2	11.5	3.7	10.5	ns
		Q <sub>A</sub> thru Q <sub>H</sub>	5.7	10.6	14	5	15.5	5.7	15	
t <sub>PZH</sub>	$\overline{\text{OE1}}$ or $\overline{\text{OE2}}$	Q <sub>A</sub> thru Q <sub>H</sub>	2.7	5.6	8	2.2	10.5	2.7	9	ns
t <sub>PZL</sub>			3.2	6.6	10	2.7	12	3.2	11	
t <sub>PHZ</sub>	$\overline{\text{OE1}}$ or $\overline{\text{OE2}}$	Q <sub>A</sub> thru Q <sub>H</sub>	1.7	4.1	6	1.7	9	1.7	7	ns
t <sub>PLZ</sub>			1.2	3.6	5.5	1.2	7.5	1.2	6.5	

† For conditions shown as MIN or MAX, use the appropriate value specified under recommended operating conditions.

# SN54F299, SN74F299 8-BIT UNIVERSAL SHIFT/STORAGE REGISTERS WITH 3-STATE OUTPUTS

SDFS071B – MARCH 1987 – REVISED APRIL 2004

The SN54F299 is obsolete and no longer supplied.

## PARAMETER MEASUREMENT INFORMATION

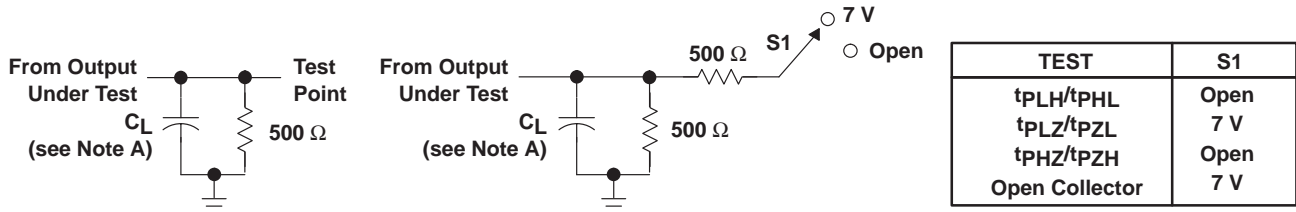

LOAD CIRCUIT FOR  
TOTEM-POLE OUTPUTS

LOAD CIRCUIT FOR  
3-STATE AND OPEN-DRAIN OUTPUTS

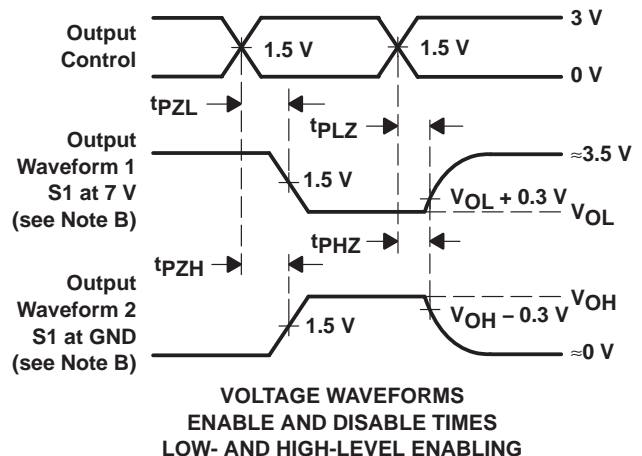
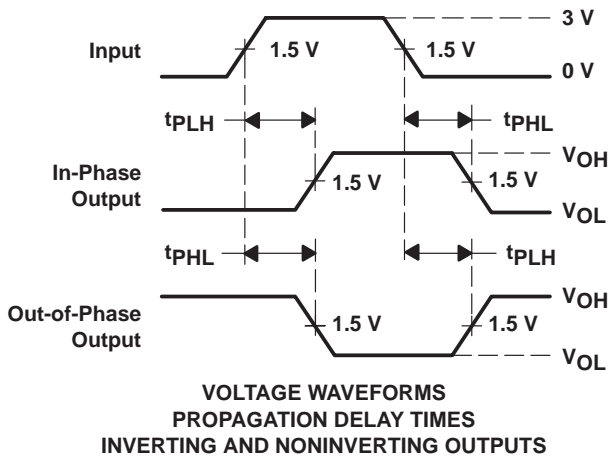
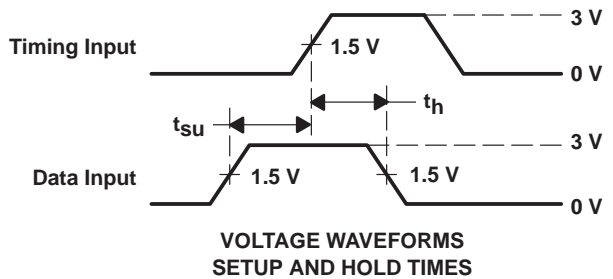
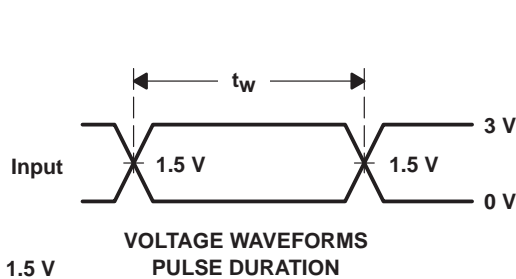

- NOTES:
- A.  $C_L$  includes probe and jig capacitance.
  - B. Waveform 1 is for an output with internal conditions such that the output is low, except when disabled by the output control. Waveform 2 is for an output with internal conditions such that the output is high, except when disabled by the output control.
  - C. All input pulses are supplied by generators having the following characteristics:  $PRR \leq 1$  MHz,  $Z_O = 50 \Omega$ ,  $t_r \leq 2.5$  ns,  $t_f \leq 2.5$  ns, duty cycle = 50%.
  - D. The outputs are measured one at a time, with one input transition per measurement.

Figure 1. Load Circuit and Voltage Waveforms

**PACKAGING INFORMATION**

Orderable Device	Status (1)	Package Type	Package Drawing	Pins	Package Qty	Eco Plan (2)	Lead/Ball Finish (6)	MSL Peak Temp (3)	Op Temp (°C)	Device Marking (4/5)	Samples
SN74F299DW	ACTIVE	SOIC	DW	20	25	Green (RoHS & no Sb/Br)	CU NIPDAU	Level-1-260C-UNLIM	0 to 70	F299	<a href="#">Samples</a>
SN74F299DWR	ACTIVE	SOIC	DW	20	2000	Green (RoHS & no Sb/Br)	CU NIPDAU	Level-1-260C-UNLIM	0 to 70	F299	<a href="#">Samples</a>
SN74F299N	ACTIVE	PDIP	N	20	20	Pb-Free (RoHS)	CU NIPDAU	N / A for Pkg Type	0 to 70	SN74F299N	<a href="#">Samples</a>

(1) The marketing status values are defined as follows:

**ACTIVE:** Product device recommended for new designs.

**LIFEBUY:** TI has announced that the device will be discontinued, and a lifetime-buy period is in effect.

**NRND:** Not recommended for new designs. Device is in production to support existing customers, but TI does not recommend using this part in a new design.

**PREVIEW:** Device has been announced but is not in production. Samples may or may not be available.

**OBSOLETE:** TI has discontinued the production of the device.

(2) **RoHS:** TI defines "RoHS" to mean semiconductor products that are compliant with the current EU RoHS requirements for all 10 RoHS substances, including the requirement that RoHS substance do not exceed 0.1% by weight in homogeneous materials. Where designed to be soldered at high temperatures, "RoHS" products are suitable for use in specified lead-free processes. TI may reference these types of products as "Pb-Free".

**RoHS Exempt:** TI defines "RoHS Exempt" to mean products that contain lead but are compliant with EU RoHS pursuant to a specific EU RoHS exemption.

**Green:** TI defines "Green" to mean the content of Chlorine (Cl) and Bromine (Br) based flame retardants meet JS709B low halogen requirements of <=1000ppm threshold. Antimony trioxide based flame retardants must also meet the <=1000ppm threshold requirement.

(3) MSL, Peak Temp. - The Moisture Sensitivity Level rating according to the JEDEC industry standard classifications, and peak solder temperature.

(4) There may be additional marking, which relates to the logo, the lot trace code information, or the environmental category on the device.

(5) Multiple Device Markings will be inside parentheses. Only one Device Marking contained in parentheses and separated by a "~" will appear on a device. If a line is indented then it is a continuation of the previous line and the two combined represent the entire Device Marking for that device.

(6) Lead/Ball Finish - Orderable Devices may have multiple material finish options. Finish options are separated by a vertical ruled line. Lead/Ball Finish values may wrap to two lines if the finish value exceeds the maximum column width.

**Important Information and Disclaimer:** The information provided on this page represents TI's knowledge and belief as of the date that it is provided. TI bases its knowledge and belief on information provided by third parties, and makes no representation or warranty as to the accuracy of such information. Efforts are underway to better integrate information from third parties. TI has taken and continues to take reasonable steps to provide representative and accurate information but may not have conducted destructive testing or chemical analysis on incoming materials and chemicals. TI and TI suppliers consider certain information to be proprietary, and thus CAS numbers and other limited information may not be available for release.

In no event shall TI's liability arising out of such information exceed the total purchase price of the TI part(s) at issue in this document sold by TI to Customer on an annual basis.

## TAPE AND REEL INFORMATION



### QUADRANT ASSIGNMENTS FOR PIN 1 ORIENTATION IN TAPE



\*All dimensions are nominal

Device	Package Type	Package Drawing	Pins	SPQ	Reel Diameter (mm)	Reel Width W1 (mm)	A0 (mm)	B0 (mm)	K0 (mm)	P1 (mm)	W (mm)	Pin1 Quadrant
SN74F299DWR	SOIC	DW	20	2000	330.0	24.4	10.8	13.0	2.7	12.0	24.0	Q1

**TAPE AND REEL BOX DIMENSIONS**



\*All dimensions are nominal

Device	Package Type	Package Drawing	Pins	SPQ	Length (mm)	Width (mm)	Height (mm)
SN74F299DWR	SOIC	DW	20	2000	367.0	367.0	45.0

N (R-PDIP-T\*\*)

PLASTIC DUAL-IN-LINE PACKAGE

16 PINS SHOWN



4040049/E 12/2002

- NOTES:
- A. All linear dimensions are in inches (millimeters).
  - B. This drawing is subject to change without notice.
  - (C) Falls within JEDEC MS-001, except 18 and 20 pin minimum body length (Dim A).
  - (D) The 20 pin end lead shoulder width is a vendor option, either half or full width.

# DW0020A



# PACKAGE OUTLINE

## SOIC - 2.65 mm max height

SOIC

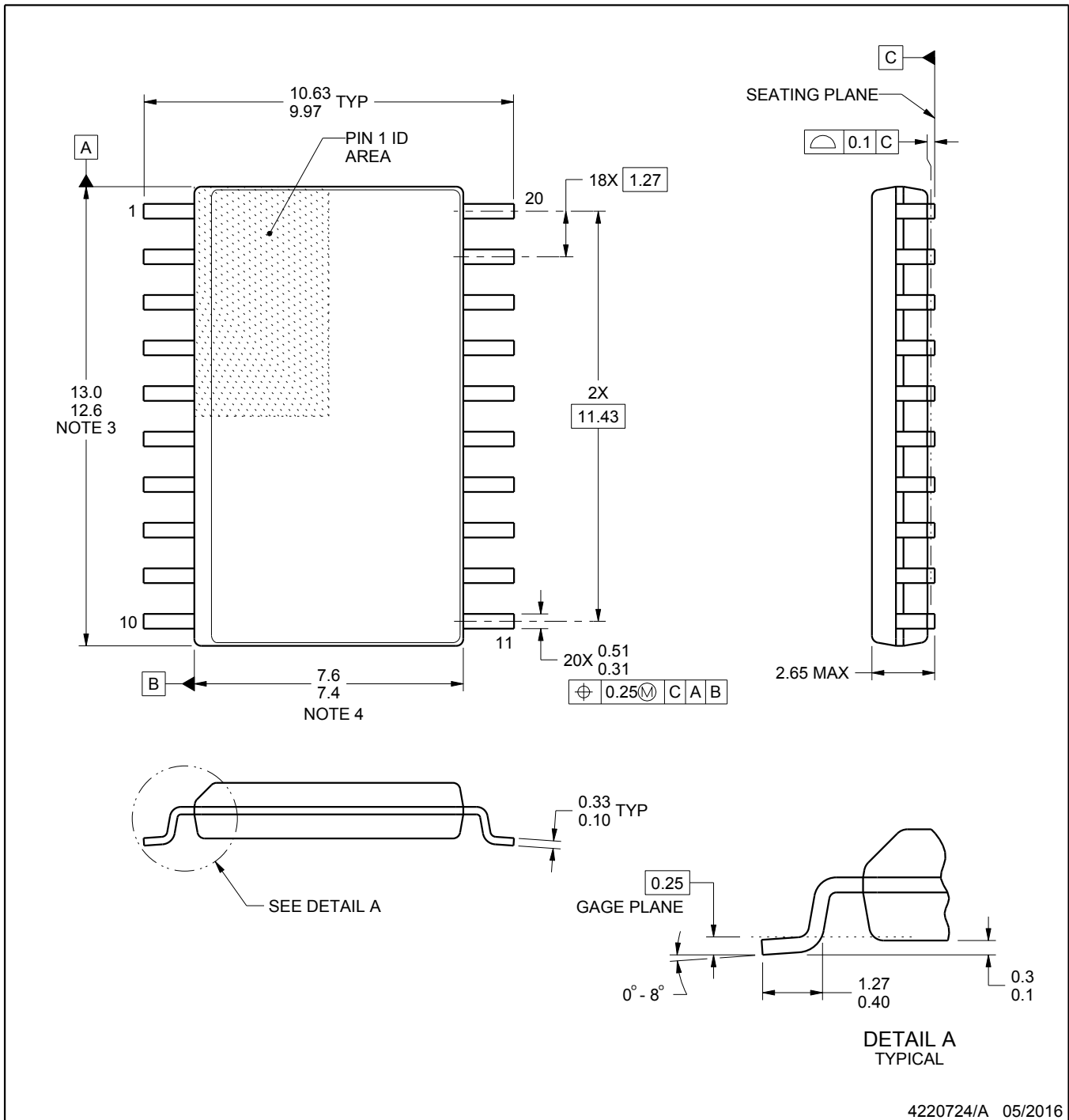

4220724/A 05/2016

### NOTES:

1. All linear dimensions are in millimeters. Dimensions in parenthesis are for reference only. Dimensioning and tolerancing per ASME Y14.5M.
2. This drawing is subject to change without notice.
3. This dimension does not include mold flash, protrusions, or gate burrs. Mold flash, protrusions, or gate burrs shall not exceed 0.15 mm per side.
4. This dimension does not include interlead flash. Interlead flash shall not exceed 0.43 mm per side.
5. Reference JEDEC registration MS-013.

# EXAMPLE BOARD LAYOUT

DW0020A

SOIC - 2.65 mm max height

SOIC



LAND PATTERN EXAMPLE  
SCALE:6X



SOLDER MASK DETAILS

4220724/A 05/2016

NOTES: (continued)

- 6. Publication IPC-7351 may have alternate designs.
- 7. Solder mask tolerances between and around signal pads can vary based on board fabrication site.

# EXAMPLE STENCIL DESIGN

DW0020A

SOIC - 2.65 mm max height

SOIC

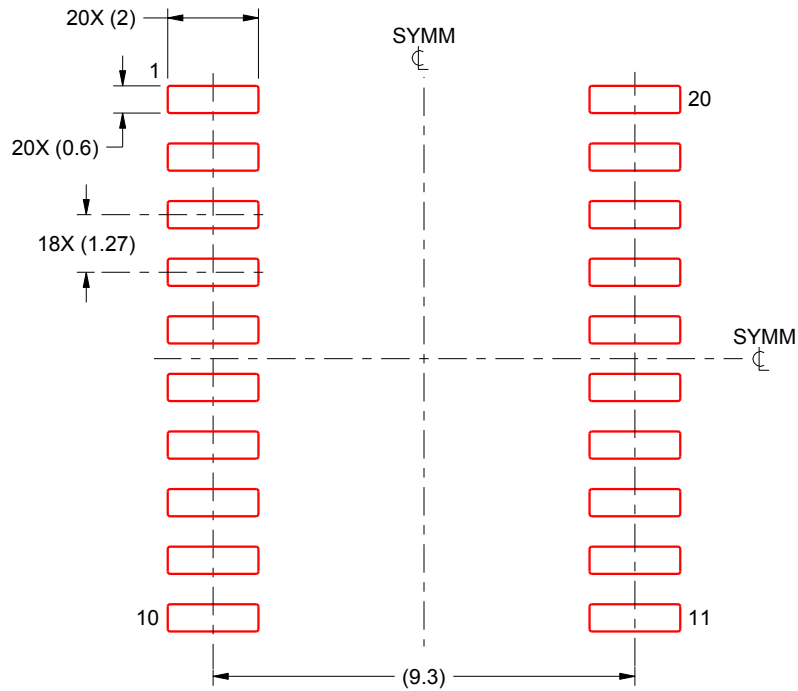

SOLDER PASTE EXAMPLE  
BASED ON 0.125 mm THICK STENCIL  
SCALE:6X

4220724/A 05/2016

NOTES: (continued)

8. Laser cutting apertures with trapezoidal walls and rounded corners may offer better paste release. IPC-7525 may have alternate design recommendations.
9. Board assembly site may have different recommendations for stencil design.

## IMPORTANT NOTICE

Texas Instruments Incorporated (TI) reserves the right to make corrections, enhancements, improvements and other changes to its semiconductor products and services per JESD46, latest issue, and to discontinue any product or service per JESD48, latest issue. Buyers should obtain the latest relevant information before placing orders and should verify that such information is current and complete.

TI's published terms of sale for semiconductor products (<http://www.ti.com/sc/docs/stdterms.htm>) apply to the sale of packaged integrated circuit products that TI has qualified and released to market. Additional terms may apply to the use or sale of other types of TI products and services.

Reproduction of significant portions of TI information in TI data sheets is permissible only if reproduction is without alteration and is accompanied by all associated warranties, conditions, limitations, and notices. TI is not responsible or liable for such reproduced documentation. Information of third parties may be subject to additional restrictions. Resale of TI products or services with statements different from or beyond the parameters stated by TI for that product or service voids all express and any implied warranties for the associated TI product or service and is an unfair and deceptive business practice. TI is not responsible or liable for any such statements.

Buyers and others who are developing systems that incorporate TI products (collectively, "Designers") understand and agree that Designers remain responsible for using their independent analysis, evaluation and judgment in designing their applications and that Designers have full and exclusive responsibility to assure the safety of Designers' applications and compliance of their applications (and of all TI products used in or for Designers' applications) with all applicable regulations, laws and other applicable requirements. Designer represents that, with respect to their applications, Designer has all the necessary expertise to create and implement safeguards that (1) anticipate dangerous consequences of failures, (2) monitor failures and their consequences, and (3) lessen the likelihood of failures that might cause harm and take appropriate actions. Designer agrees that prior to using or distributing any applications that include TI products, Designer will thoroughly test such applications and the functionality of such TI products as used in such applications.

TI's provision of technical, application or other design advice, quality characterization, reliability data or other services or information, including, but not limited to, reference designs and materials relating to evaluation modules, (collectively, "TI Resources") are intended to assist designers who are developing applications that incorporate TI products; by downloading, accessing or using TI Resources in any way, Designer (individually or, if Designer is acting on behalf of a company, Designer's company) agrees to use any particular TI Resource solely for this purpose and subject to the terms of this Notice.

TI's provision of TI Resources does not expand or otherwise alter TI's applicable published warranties or warranty disclaimers for TI products, and no additional obligations or liabilities arise from TI providing such TI Resources. TI reserves the right to make corrections, enhancements, improvements and other changes to its TI Resources. TI has not conducted any testing other than that specifically described in the published documentation for a particular TI Resource.

Designer is authorized to use, copy and modify any individual TI Resource only in connection with the development of applications that include the TI product(s) identified in such TI Resource. NO OTHER LICENSE, EXPRESS OR IMPLIED, BY ESTOPPEL OR OTHERWISE TO ANY OTHER TI INTELLECTUAL PROPERTY RIGHT, AND NO LICENSE TO ANY TECHNOLOGY OR INTELLECTUAL PROPERTY RIGHT OF TI OR ANY THIRD PARTY IS GRANTED HEREIN, including but not limited to any patent right, copyright, mask work right, or other intellectual property right relating to any combination, machine, or process in which TI products or services are used. Information regarding or referencing third-party products or services does not constitute a license to use such products or services, or a warranty or endorsement thereof. Use of TI Resources may require a license from a third party under the patents or other intellectual property of the third party, or a license from TI under the patents or other intellectual property of TI.

TI RESOURCES ARE PROVIDED "AS IS" AND WITH ALL FAULTS. TI DISCLAIMS ALL OTHER WARRANTIES OR REPRESENTATIONS, EXPRESS OR IMPLIED, REGARDING RESOURCES OR USE THEREOF, INCLUDING BUT NOT LIMITED TO ACCURACY OR COMPLETENESS, TITLE, ANY EPIDEMIC FAILURE WARRANTY AND ANY IMPLIED WARRANTIES OF MERCHANTABILITY, FITNESS FOR A PARTICULAR PURPOSE, AND NON-INFRINGEMENT OF ANY THIRD PARTY INTELLECTUAL PROPERTY RIGHTS. TI SHALL NOT BE LIABLE FOR AND SHALL NOT DEFEND OR INDEMNIFY DESIGNER AGAINST ANY CLAIM, INCLUDING BUT NOT LIMITED TO ANY INFRINGEMENT CLAIM THAT RELATES TO OR IS BASED ON ANY COMBINATION OF PRODUCTS EVEN IF DESCRIBED IN TI RESOURCES OR OTHERWISE. IN NO EVENT SHALL TI BE LIABLE FOR ANY ACTUAL, DIRECT, SPECIAL, COLLATERAL, INDIRECT, PUNITIVE, INCIDENTAL, CONSEQUENTIAL OR EXEMPLARY DAMAGES IN CONNECTION WITH OR ARISING OUT OF TI RESOURCES OR USE THEREOF, AND REGARDLESS OF WHETHER TI HAS BEEN ADVISED OF THE POSSIBILITY OF SUCH DAMAGES.

Unless TI has explicitly designated an individual product as meeting the requirements of a particular industry standard (e.g., ISO/TS 16949 and ISO 26262), TI is not responsible for any failure to meet such industry standard requirements.

Where TI specifically promotes products as facilitating functional safety or as compliant with industry functional safety standards, such products are intended to help enable customers to design and create their own applications that meet applicable functional safety standards and requirements. Using products in an application does not by itself establish any safety features in the application. Designers must ensure compliance with safety-related requirements and standards applicable to their applications. Designer may not use any TI products in life-critical medical equipment unless authorized officers of the parties have executed a special contract specifically governing such use. Life-critical medical equipment is medical equipment where failure of such equipment would cause serious bodily injury or death (e.g., life support, pacemakers, defibrillators, heart pumps, neurostimulators, and implantables). Such equipment includes, without limitation, all medical devices identified by the U.S. Food and Drug Administration as Class III devices and equivalent classifications outside the U.S.

TI may expressly designate certain products as completing a particular qualification (e.g., Q100, Military Grade, or Enhanced Product). Designers agree that it has the necessary expertise to select the product with the appropriate qualification designation for their applications and that proper product selection is at Designers' own risk. Designers are solely responsible for compliance with all legal and regulatory requirements in connection with such selection.

Designer will fully indemnify TI and its representatives against any damages, costs, losses, and/or liabilities arising out of Designer's non-compliance with the terms and provisions of this Notice.

## Looking for pricing, stock, or lifecycle information?

Click below to explore more details on WIN SOURCE:

 [View SN74F299DWR on WIN SOURCE](#)

 [Texas Instruments](#) Information

## Optimize Your Supply Chain with WIN SOURCE Solutions

-  Global Sourcing Solution
-  Obsolete Management
-  Cost Control Management
-  Shortage Management
-  Alternative Solution
-  Excess Inventory Management