



THE DATASHEET OF SI2303



SI2303 P-channel 30-V(D-S) MOSFET

V(BR)DSS	RDS(on)MAX	ID
-30 V	190mΩ@-10V	-1.7A
	330mΩ@-4.5V	

FEATURE

※ TrenchFET Power MOSFET

APPLICATION

- ※ Load Switch for Portable Devices
- ※ DC/DC Converter

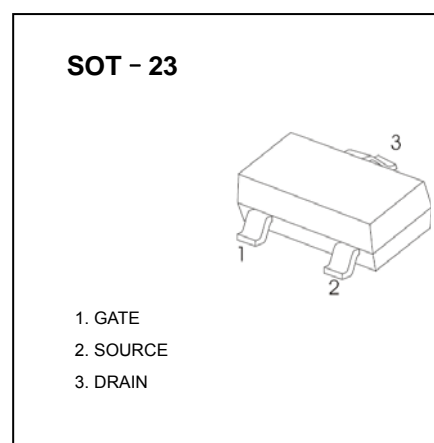

MARKING

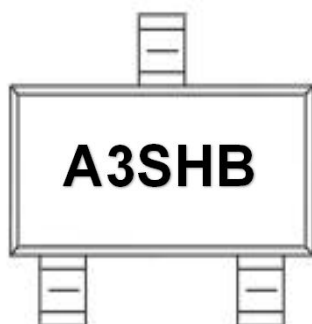

Equivalent Circuit

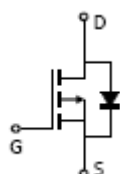

Maximum ratings (Ta=25°C unless otherwise noted)

Parameter	Symbol	Value	Unit
Drain-Source Voltage	VDS	-30	V
Gate-Source Voltage	VGS	±20	
Continuous Drain Current	ID	-1.7	A
Pulsed Diode Curren	IDM	-10	
Continuous Source-Drain Current(Diode Conduction)	IS	-1	
Power Dissipation	PD	0.9	W
Thermal Resistance from Junction to Ambient (t≤5s)	RθJA	357	°C/W
Operating Junction	TJ	150	°C
Storage Temperature	TSTG	-55~+150	°C

SOT-23 Plastic-Encapsulate MOSFETS
MOSFET ELECTRICAL CHARACTERISTICS
Static Electrical Characteristics (Ta = 25 °C Unless Otherwise Noted)

Parameter	Symbol	Test Condition	Min	Typ	Max	Unit
Static						
Drain-source breakdown voltage	V(BR)DSS	VGS = 0V, ID = -250μA	-30			V
Gate-source threshold voltage	VGS(th)	VDS = VGS, ID = -250μA	-1		-3	V
Gate-source leakage	IGSS	VDS = 0V, VGS = ±20V			±100	nA
Zero gate voltage drain current	IDSS	VDS = -30V, VGS = 0V			-1	μA
Drain-source on-state resistancea	RDS(on)	VGS = -10V, ID = -1.7A		120	190	mΩ
		VGS = -4.5V, ID = -1.3A		150	330	mΩ
Forward transconductancea	gfs	VDS = -10V, ID = -1.7A	5.5			S
Diode forward voltage	VSD	IS=-1A, VGS=0V		-0.8	-1.2	V
Dynamic						
Input capacitance	Ciss	VDS = -15V, VGS = 0V, f=1MHz		155		pF
Output capacitance	Coss			35		pF
Reverse transfer capacitanceb	Crss			25		pF
Total gate charge	Qg	VDS = -15V, VGS = -4.5V, ID = -1.7A		2	4	nC
Gate-source charge	Qgs			0.6		nC
Gate-drain charge	Qgd			1		nC
Gate resistance	Rg	f=1MHz		8.5	17	Ω
Switchingb						
Turn-on delay time	td(on)	VDD= -15V RL=10Ω, ID ≈ -1.5A, VGEN=- 4.5V,Rg=5Ω		36	44	ns
Rise time	tr			37	45	ns
Turn-off delay time	td(off)			12	18	ns
Fall time	tf			9	14	ns
Drain-source body diode characteristics						
Continuous Source-Drain Diode Current	IS	Tc=25°C			-1.75	A
Pulsed Diode forward Curren	ISM				-10	A

Note :

1. Repetitive Rating : Pulse width limited by maximum junction temperature.
2. Surface Mounted on FR4 Board, t < 5 sec.
3. Pulse Test : Pulse Width≤300μs, Duty Cycle ≤ 2%.
4. Guaranteed by design, not subject to production testing.

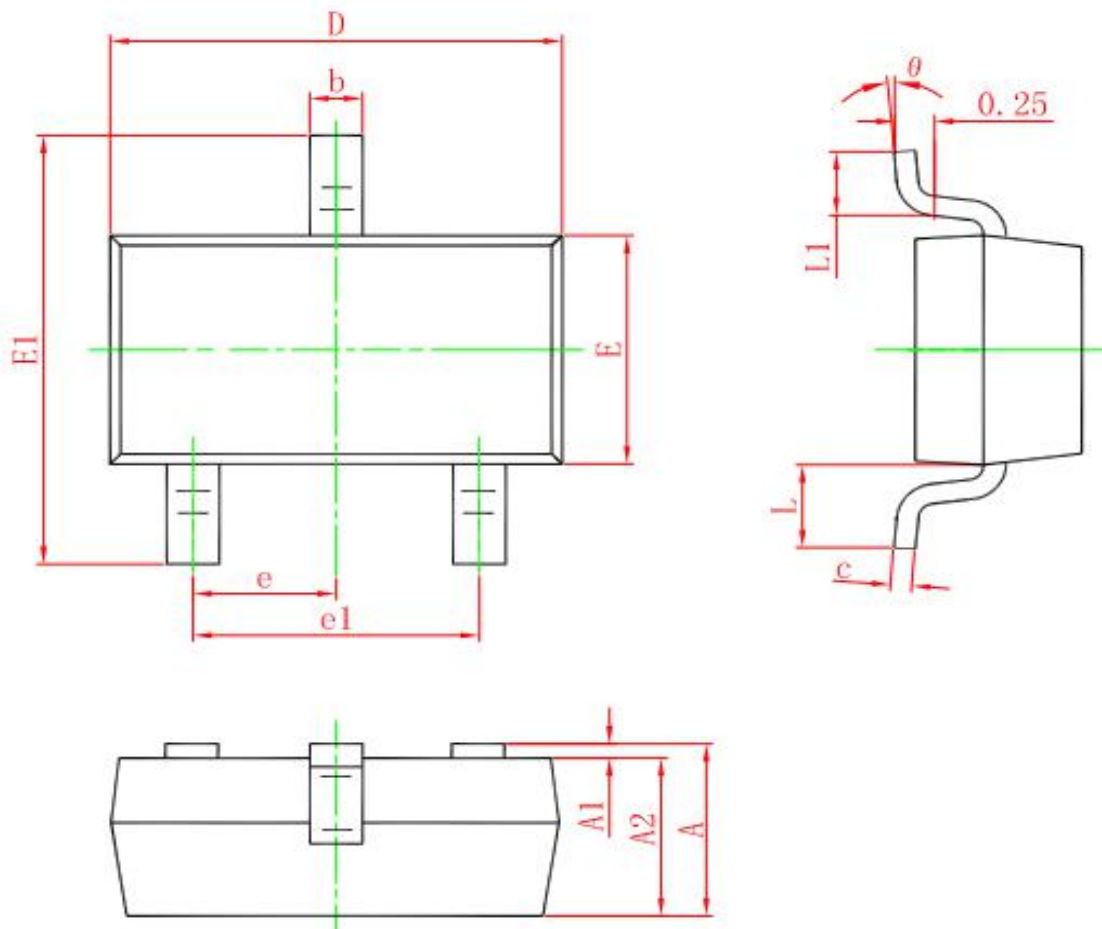

SOT-23 PACKAGE OUTLINE DIMENSIONS









Symbol	Dimensions In Millimeters		Dimensions In Inches	
	Min.	Max.	Min.	Max.
A	0.900	1.150	0.035	0.045
A1	0.000	0.100	0.000	0.004
A2	0.900	1.050	0.035	0.041
b	0.300	0.500	0.012	0.020
c	0.080	0.150	0.003	0.006
D	2.800	3.000	0.110	0.118
E	1.200	1.400	0.047	0.055
E1	2.250	2.550	0.089	0.100
e	0.950 TYP.		0.037 TYP.	
e1	1.800	2.000	0.071	0.079
L	0.550 REF.		0.022 REF.	
L1	0.300	0.500	0.012	0.020
θ	0°	8°	0°	8°

Looking for pricing, stock, or lifecycle information?

Click below to explore more details on WIN SOURCE:

-  [View SI2303 on WIN SOURCE](#)
-  [NXP / Nexperia Information](#)

Optimize Your Supply Chain with WIN SOURCE Solutions

-  Global Sourcing Solution
-  Obsolete Management
-  Cost Control Management
-  Shortage Management
-  Alternative Solution
-  Excess Inventory Management