



**THE DATASHEET OF
DDTC122LE-7-F**



Features

- Epitaxial Planar Die Construction
- Complementary PNP Types Available (DDTA)
- Built-In Biasing Resistors
- **Totally Lead-Free & Fully RoHS Compliant (Notes 1 & 2)**
- **Halogen and Antimony Free "Green" Device (Note 3)**
- **Qualified to AEC-Q101 Standards for High Reliability**

Part Number	R1 (NOM)	R2 (NOM)	Marking
DDTC122LE	0.22kΩ	10kΩ	N81
DDTC142JE	0.47kΩ	10kΩ	N82
DDTC122TE	0.22kΩ	OPEN	N83
DDTC142TE	0.47kΩ	OPEN	N84

Mechanical Data

- Case: SOT523
- Case Material: Molded Plastic, "Green" Molding Compound. UL Flammability Classification Rating 94V-0
- Moisture Sensitivity: Level 1 per J-STD-020
- Terminals: Matte Tin Finish. Solderable per MIL-STD-202, Method 208③
- Weight: 0.002 grams (Approximate)

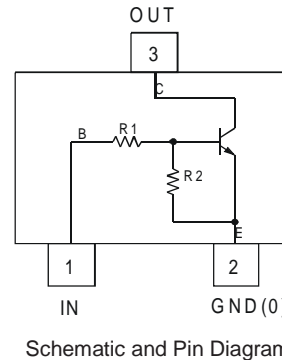

Ordering Information (Note 4)

Part Number	Compliance	Reel Size (inches)	Tape Width (mm)	Quantity Per Reel
DDTC122LE-7-F	AEC-Q101	7	8	3,000
DDTC142JE-7-F	AEC-Q101	7	8	3,000
DDTC122TE-7-F	AEC-Q101	7	8	3,000
DDTC142TE-7-F	AEC-Q101	7	8	3,000

- Notes:
1. No purposely added lead. Fully EU Directive 2002/95/EC (RoHS), 2011/65/EU (RoHS 2) & 2015/863/EU (RoHS 3) compliant.
 2. See <https://www.diodes.com/quality/lead-free/> for more information about Diodes Incorporated's definitions of Halogen- and Antimony-free, "Green" and Lead-free.
 3. Halogen- and Antimony-free "Green" products are defined as those which contain <900ppm bromine, <900ppm chlorine (<1500ppm total Br + Cl) and <1000ppm antimony compounds.
 4. For packaging details, go to our website at <https://www.diodes.com/design/support/packaging/diodes-packaging/>.

Marking Information

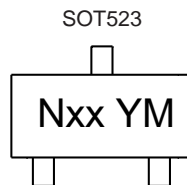

Nxx = Product Type Marking Code
(See Table in Features)
YM = Date Code Marking
Y or \bar{Y} = Year (ex: F = 2018)
M or \bar{M} = Month (ex: 9 = September)

Date Code Key

Year	2018	2019	2020	2021	2022	2023	2024	2025	2026	2027
Code	F	G	H	I	J	K	L	M	N	O

Month	Jan	Feb	Mar	Apr	May	Jun	Jul	Aug	Sep	Oct	Nov	Dec
Code	1	2	3	4	5	6	7	8	9	O	N	D

Absolute Maximum Ratings (@T_A = +25°C, unless otherwise specified.)

Characteristic		Symbol	Value	Unit
Supply Voltage, (3) to (2)		V _{CC}	50	V
Input Voltage, (1) to (2)	DDTC122LE DDTC142JE	V _{IN}	-5 to +6 -5 to +6	V
Input Voltage, (2) to (1)	DDTC122TE DDTC142TE	V _{EBO (MAX)}	5	V
Output Current	All	I _C	100	mA

Thermal Characteristics (@T_A = +25°C, unless otherwise specified.)

Characteristic		Symbol	Value	Unit
Power Dissipation		P _D	150	mW
Thermal Resistance, Junction to Ambient Air (Note 5)		R _{θJA}	625	°C/W
Operating and Storage Temperature Range		T _J , T _{STG}	-55 to +150	°C

Note 5: Mounted on FR-4 PC Board with minimum recommended pad layout.

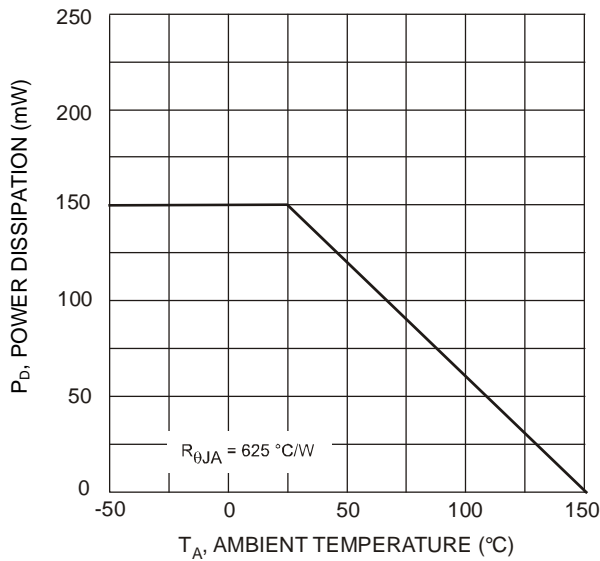

Fig. 1 Power Derating Curve

Electrical Characteristics R1, R2 Types (@T_A = +25°C, unless otherwise specified.)

Characteristic		Symbol	Min	Typ	Max	Unit	Test Condition
Input Voltage	DDTC122LE DDTC142JE	V _{I(OFF)}	0.3 0.3	—	—	V	V _{CC} = 5V, I _O = 100μA
	DDTC122LE DDTC142JE	V _{I(ON)}	—	—	2.0 2.0	V	V _O = 0.3V, I _O = 20mA V _O = 0.3V, I _O = 20mA
Output Voltage		V _{O(ON)}	—	—	0.3	V	I _O /I _I = 5mA/0.25mA
Input Current	DDTC122LE DDTC142JE	I _I	—	—	28 13	mA	V _I = 5V
Output Current		I _{O(OFF)}	—	—	0.5	μA	V _{CC} = 50V, V _I = 0V
DC Current Gain	DDTC122LE DDTC142JE	G _I	56 56	—	—	—	V _O = 5V, I _O = 10mA
Gain-Bandwidth Product (Note 6)		f _T	—	200	—	MHz	V _{CE} = 10V, I _E = 5mA, f = 100MHz

Electrical Characteristics R1- Only Type (@T_A = +25°C, unless otherwise specified.)

Characteristic		Symbol	Min	Typ	Max	Unit	Test Condition
Collector-Base Breakdown Voltage		BV _{CB0}	50	—	—	V	I _C = 50μA
Collector-Emitter Breakdown Voltage		BV _{CEO}	40	—	—	V	I _C = 1mA
Emitter-Base Breakdown Voltage	DDTC122TE DDTC142TE	BV _{EBO}	5	—	—	V	I _E = 50μA I _E = 50μA
Collector Cutoff Current		I _{CB0}	—	—	0.5	μA	V _{CB} = 50V
Emitter Cutoff Current	DDTC122TE DDTC142TE	I _{EBO}	— —	—	0.5 0.5	μA	V _{EB} = 4V
Collector-Emitter Saturation Voltage		V _{CE(SAT)}	—	—	0.3	V	I _C = 5mA, I _B = 0.25mA
DC Current Transfer Ratio	DDTC122TE DDTC142TE	h _{FE}	100 100	250 250	600 600	—	I _C = 1mA, V _{CE} = 5V
Gain-Bandwidth Product (Note 6)		f _T	—	200	—	MHz	V _{CE} = 10V, I _E = -5mA, f = 100MHz

Note 6: Transistor – For Reference only.

Package Outline Dimensions

Please see <http://www.diodes.com/package-outlines.html> for the latest version.

SOT523

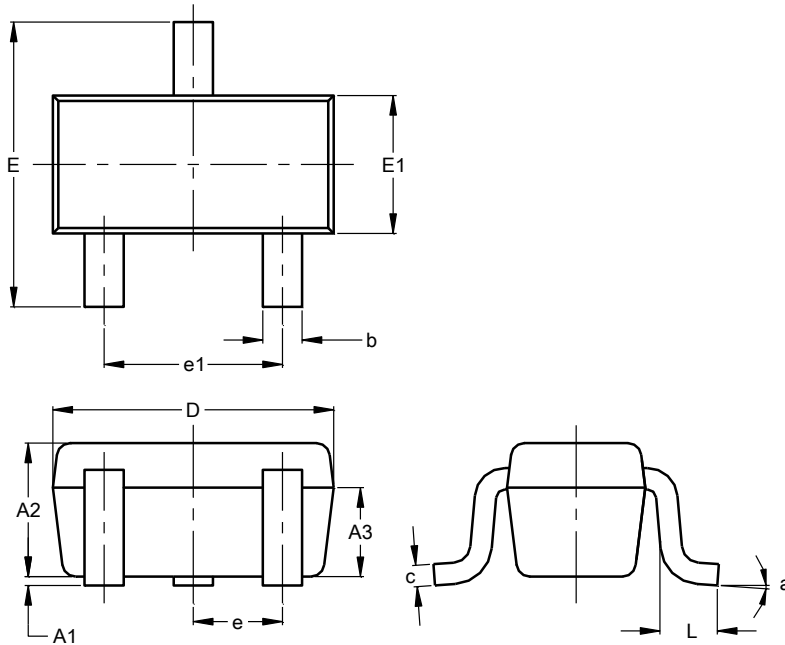

SOT523			
Dim	Min	Max	Typ
A1	0.00	0.10	0.05
A2	0.60	0.80	0.75
A3	0.45	0.65	0.50
b	0.15	0.30	0.22
c	0.10	0.20	0.12
D	1.50	1.70	1.60
E	1.45	1.75	1.60
E1	0.75	0.85	0.80
e	0.50 BSC		
e1	0.90	1.10	1.00
L	0.20	0.40	0.33
a	0°	--	8°
All Dimensions in mm			

Suggested Pad Layout

Please see <http://www.diodes.com/package-outlines.html> for the latest version.

SOT523

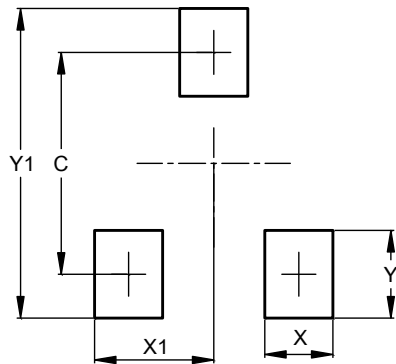

Dimensions	Value (in mm)
C	1.29
X	0.40
X1	0.70
Y	0.51
Y1	1.80

IMPORTANT NOTICE

DIODES INCORPORATED MAKES NO WARRANTY OF ANY KIND, EXPRESS OR IMPLIED, WITH REGARDS TO THIS DOCUMENT, INCLUDING, BUT NOT LIMITED TO, THE IMPLIED WARRANTIES OF MERCHANTABILITY AND FITNESS FOR A PARTICULAR PURPOSE (AND THEIR EQUIVALENTS UNDER THE LAWS OF ANY JURISDICTION).

Diodes Incorporated and its subsidiaries reserve the right to make modifications, enhancements, improvements, corrections or other changes without further notice to this document and any product described herein. Diodes Incorporated does not assume any liability arising out of the application or use of this document or any product described herein; neither does Diodes Incorporated convey any license under its patent or trademark rights, nor the rights of others. Any Customer or user of this document or products described herein in such applications shall assume all risks of such use and will agree to hold Diodes Incorporated and all the companies whose products are represented on Diodes Incorporated website, harmless against all damages.

Diodes Incorporated does not warrant or accept any liability whatsoever in respect of any products purchased through unauthorized sales channel. Should Customers purchase or use Diodes Incorporated products for any unintended or unauthorized application, Customers shall indemnify and hold Diodes Incorporated and its representatives harmless against all claims, damages, expenses, and attorney fees arising out of, directly or indirectly, any claim of personal injury or death associated with such unintended or unauthorized application.

Products described herein may be covered by one or more United States, international or foreign patents pending. Product names and markings noted herein may also be covered by one or more United States, international or foreign trademarks.

This document is written in English but may be translated into multiple languages for reference. Only the English version of this document is the final and determinative format released by Diodes Incorporated.

LIFE SUPPORT

Diodes Incorporated products are specifically not authorized for use as critical components in life support devices or systems without the express written approval of the Chief Executive Officer of Diodes Incorporated. As used herein:

A. Life support devices or systems are devices or systems which:

1. are intended to implant into the body, or
2. support or sustain life and whose failure to perform when properly used in accordance with instructions for use provided in the labeling can be reasonably expected to result in significant injury to the user.

B. A critical component is any component in a life support device or system whose failure to perform can be reasonably expected to cause the failure of the life support device or to affect its safety or effectiveness.

Customers represent that they have all necessary expertise in the safety and regulatory ramifications of their life support devices or systems, and acknowledge and agree that they are solely responsible for all legal, regulatory and safety-related requirements concerning their products and any use of Diodes Incorporated products in such safety-critical, life support devices or systems, notwithstanding any devices- or systems-related information or support that may be provided by Diodes Incorporated. Further, Customers must fully indemnify Diodes Incorporated and its representatives against any damages arising out of the use of Diodes Incorporated products in such safety-critical, life support devices or systems.

Copyright © 2018, Diodes Incorporated

www.diodes.com

Looking for pricing, stock, or lifecycle information?

Click below to explore more details on WIN SOURCE:

 [View DDTTC122LE-7-F on WIN SOURCE](#)

 [Diodes Incorporated](#) Information

Optimize Your Supply Chain with WIN SOURCE Solutions

-  Global Sourcing Solution
-  Obsolete Management
-  Cost Control Management
-  Shortage Management
-  Alternative Solution
-  Excess Inventory Management