



**THE DATASHEET OF  
ADS1226IRGVT**



## 24-Bit Analog-to-Digital Converter with One- and Two-Channel Differential Inputs and Internal Oscillator

### FEATURES

- **100SPS Data Rate (High-Speed Mode)**
- **Single-Cycle Settling**
- **Easy Conversion Control with START Pin**
- **Automatic Shutdown**
- **Low Noise:  $4\mu\text{V}_{\text{RMS}}$  Noise (High-Resolution Mode)**
- **Input Multiplexer with Two Differential Channels (ADS1226)**
- **Voltage Reference Supports Ratiometric Measurements**
- **Self-Calibrating**
- **Simple Read-Only 2-Wire Serial Interface**
- **Internal High-Impedance Input Buffer**
- **Internal Temperature Sensor**
- **Internal Oscillator**
- **Low-Power: 1mW While Operating,  $< 1\mu\text{A}$  During Shutdown**
- **Analog and Digital Supplies: 2.7V to 5.5V**

### APPLICATIONS

- **Hand-Held Instrumentation**
- **Portable Medical Equipment**
- **Industrial Process Control**

### DESCRIPTION

The ADS1225 and ADS1226 are 24-bit delta-sigma analog-to-digital (A/D) converters. They offer excellent performance, ease-of-use, and low power in a small 4mm × 4mm QFN package and are well-suited for demanding high-resolution measurements, especially in portable and other space-saving and power-constrained applications.

The ADS1225 and ADS1226 convert on command using a dedicated START pin. Simply pulse this pin to initiate a conversion. Data is read in a single cycle for retrieval over a 2-wire serial interface that easily connects to popular microcontrollers like the MSP430. After the conversion completes, the ADS1225 and ADS1226 automatically shuts down all circuitry.

Internal features include a two-channel multiplexer (ADS1226), selectable input buffer, temperature sensor, and oscillator. The full-scale range is defined by the external voltage reference with support provided for up to a 5V differential input signal. Two operating modes allow for speed (100SPS data rate,  $15\mu\text{V}_{\text{RMS}}$  noise) or resolution ( $4\mu\text{V}_{\text{RMS}}$  noise, 16SPS data rate).

The ADS1225/6 supports 2.7 to 5.5V analog and digital supplies. Power consumption is 1mW while converting with 3V supplies. The ADS1225 and ADS1226 are fully specified over an extended industrial temperature range of  $-40^{\circ}\text{C}$  to  $+105^{\circ}\text{C}$ .

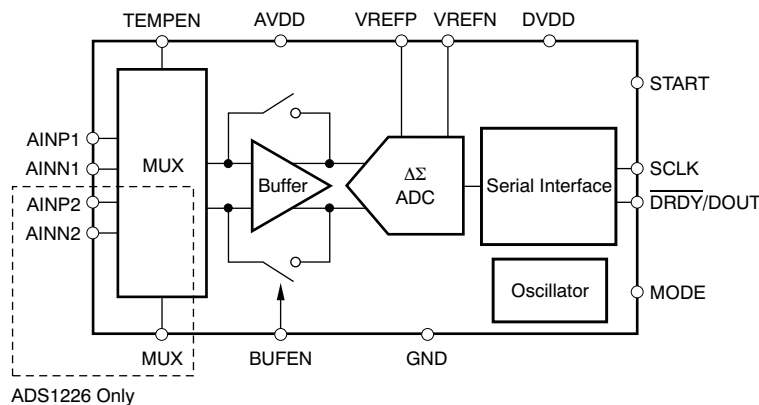

Please be aware that an important notice concerning availability, standard warranty, and use in critical applications of Texas Instruments semiconductor products and disclaimers thereto appears at the end of this data sheet.

All trademarks are the property of their respective owners.



This integrated circuit can be damaged by ESD. Texas Instruments recommends that all integrated circuits be handled with appropriate precautions. Failure to observe proper handling and installation procedures can cause damage.

ESD damage can range from subtle performance degradation to complete device failure. Precision integrated circuits may be more susceptible to damage because very small parametric changes could cause the device not to meet its published specifications.

## ORDERING INFORMATION

For the most current package and ordering information, see the Package Option Addendum located at the end of this data sheet or see the TI web site at [www.ti.com](http://www.ti.com).

## ABSOLUTE MAXIMUM RATINGS<sup>(1)</sup>

Over operating free-air temperature range, unless otherwise noted.

	ADS1225, ADS1226	UNIT
AVDD to GND	–0.3 to +6	V
DVDD to GND	–0.3 to +6	V
Input current	100, momentary	mA
	10, continuous	mA
Analog input voltage to GND	–0.3 to AVDD +0.3	V
Digital input voltage to GND	–0.3 to AVDD +0.3	V
Maximum junction temperature	+150	°C
Operating temperature range	–55 to +125	°C
Storage temperature range	–50 to +150	°C

- (1) Stresses above these ratings may cause permanent damage. Exposure to absolute maximum conditions for extended periods may degrade device reliability. These are stress ratings only, and functional operation of the device at these or any other conditions beyond those specified is not implied.

## ELECTRICAL CHARACTERISTICS

All specifications at  $T_A = -40^{\circ}\text{C}$  to  $+105^{\circ}\text{C}$ ,  $AVDD = +5\text{V}$ ,  $DVDD = +3\text{V}$ , and  $V_{REF} = +5\text{V}$ , unless otherwise noted.

PARAMETER	TEST CONDITIONS	ADS1225, ADS1226			UNIT
		MIN	TYP	MAX	
<b>Analog Input</b>					
Full-scale input voltage	AINP – AINN	$\pm V_{REF}$			V
Absolute input voltage	Buffer off; AINP, AINN with respect to GND	GND – 0.1		AVDD + 0.1	V
	Buffer on; AINP, AINN with respect to GND	GND + 0.05		AVDD – 1.5	V
Differential input impedance	Buffer off		2		M $\Omega$
	Buffer on		1		G $\Omega$
Common-mode input impedance	Buffer off		4		M $\Omega$
<b>System Performance</b>					
Resolution		24			Bits
Data rate	High-Speed mode	75	100	125	SPS <sup>(1)</sup>
	High-Resolution mode	12	16	22	SPS <sup>(1)</sup>
Integral nonlinearity (INL)	End-point fit		0.0005	0.0020	% of FSR <sup>(2)</sup>
Offset error			60	200	$\mu\text{V}$
Offset error drift			0.3		$\mu\text{V}/^{\circ}\text{C}$
Gain error			0.004	0.025	%
Gain error drift			0.3		ppm/ $^{\circ}\text{C}$
Common-mode rejection	At dc	85	95		dB
Analog power-supply rejection	At dc, $\pm 10\%$ $\Delta$ in AVDD		95		dB
Digital power-supply rejection	At dc, DVDD = 2.7V to 5.5V		80		dB
Noise	High-Speed mode		1.5		ppm of FSR, rms
	High-Resolution mode		0.4		ppm of FSR, rms
<b>Temperature Sensor</b>					
Temperature sensor voltage	$T_A = +25^{\circ}\text{C}$		106		mV
Temperature sensor coefficient			360		$\mu\text{V}/^{\circ}\text{C}$
<b>Voltage Reference Input</b>					
Reference input voltage	$V_{REF} = V_{REFP} - V_{REFN}$	0.5		AVDD	V
Negative reference input		GND – 0.1		$V_{REFP} - 0.5$	V
Positive reference input		$V_{REFN} + 0.5$		AVDD + 0.1	V
Voltage reference impedance			1.5		M $\Omega$

(1) SPS = samples per second.

(2) FSR = full-scale range =  $2 \times V_{REF}$ .

### ELECTRICAL CHARACTERISTICS (continued)

All specifications at  $T_A = -40^{\circ}\text{C}$  to  $+105^{\circ}\text{C}$ ,  $\text{AVDD} = +5\text{V}$ ,  $\text{DVDD} = +3\text{V}$ , and  $V_{\text{REF}} = +5\text{V}$ , unless otherwise noted.

PARAMETER	TEST CONDITIONS	ADS1225, ADS1226			UNIT
		MIN	TYP	MAX	
<b>Digital Input/Output</b>					
Logic levels	$V_{\text{IH}}$		0.8 DVDD	DVDD + 0.1	V
	$V_{\text{IL}}$		GND – 0.1	0.2 DVDD	V
	$V_{\text{OH}}$	$I_{\text{OH}} = 1\text{mA}$	0.8 DVDD		V
	$V_{\text{OL}}$	$I_{\text{OL}} = 1\text{mA}$		0.2 DVDD	V
Input leakage				±10	μA
<b>Power Supply</b>					
AVDD		2.7		5.5	V
DVDD		2.7		5.5	V
AVDD current	Shutdown		< 1		μA
	AVDD = 5V, converting, buffer off		285		μA
	AVDD = 5V, converting, buffer on		405		μA
	AVDD = 3V, converting, buffer off		265		μA
	AVDD = 3V, converting, buffer on		385		μA
DVDD current	Shutdown		< 1		μA
	DVDD = 5V, converting		90		μA
	DVDD = 3V, converting		55		μA
Total power dissipation	AVDD = 5V, DVDD = 3V, buffer off		1.6	2.5	mW
	AVDD = DVDD = 3V, buffer off		1		mW
<b>Temperature Range</b>					
Specified		–40		+105	°C
Operating		–55		+125	°C
Storage		–60		+150	°C

## PIN CONFIGURATION

RGV PACKAGE  
QFN-16, 4.0mm × 4.0mm  
(TOP VIEW)

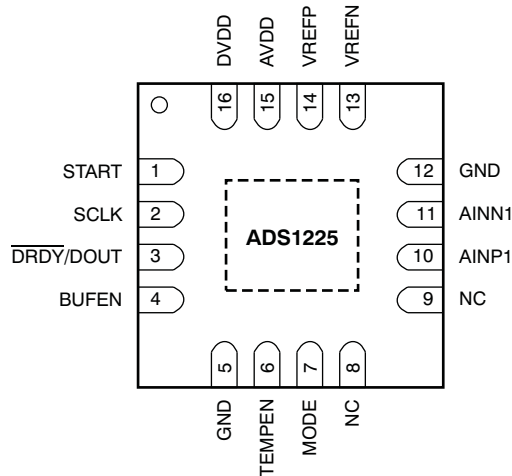

## PIN DESCRIPTIONS—ADS1225

TERMINAL		ANALOG/DIGITAL INPUT/OUTPUT	DESCRIPTION
NAME	NO.		
START	1	Digital Input	High: Start conversions; Low: Shutdown
SCLK	2	Digital Input	Serial clock input
$\overline{\text{DRDY}}/\text{DOUT}$	3	Digital Output	Dual-purpose output: Data ready: indicates valid data by going low. Data output: outputs data, MSB first, on the rising edge of SCLK.
BUFEN	4	Digital Input	Enables buffer after MUX
GND	5	Ground	Analog and digital ground
TEMPEN	6	Digital Input	Selects temperature sensor input from MUX
MODE	7	Digital Input	Selects between High-Speed and High-Resolution modes
NC	8		No connect
NC	9		No connect
AINP1	10	Analog Input	Analog channel 1 positive input
AINN1	11	Analog Input	Analog channel 1 negative input
GND	12	Ground	Analog and digital ground
VREFN	13	Analog Input	Negative reference input
VREFP	14	Analog Input	Positive reference input
AVDD	15	Analog	Analog power supply
DVDD	16	Digital	Digital power supply

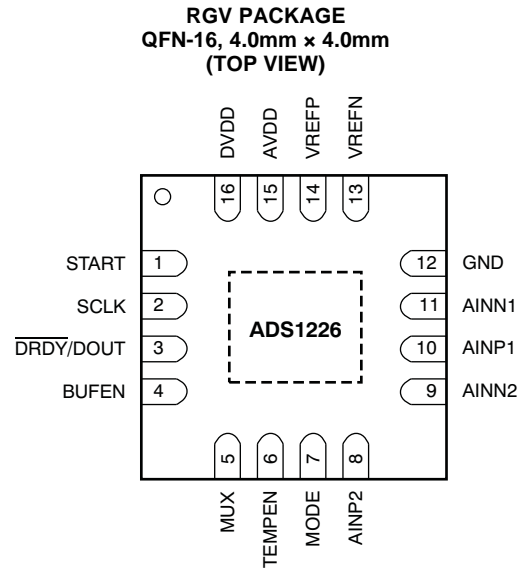

**PIN DESCRIPTIONS—ADS1226**

TERMINAL		ANALOG/DIGITAL INPUT/OUTPUT	DESCRIPTION
NAME	NO.		
START	1	Digital Input	High: Start conversions; Low: Shutdown
SCLK	2	Digital Input	Serial clock input
$\overline{\text{DRDY}}/\text{DOUT}$	3	Digital Output	Dual-purpose output: Data ready: indicates valid data by going low. Data output: outputs data, MSB first, on the rising edge of SCLK.
BUFEN	4	Digital Input	Enables buffer after MUX
MUX	5	Digital Input	Selects analog input from MUX
TEMPEN	6	Digital Input	Selects temperature sensor input from MUX
MODE	7	Digital Input	Selects between High-Speed and High-Resolution modes
AINP2	8	Analog Input	Analog channel 2 positive input
AINN2	9	Analog Input	Analog channel 2 negative input
AINP1	10	Analog Input	Analog channel 1 positive input
AINN1	11	Analog Input	Analog channel 1 negative input
GND	12	Ground	Analog and digital ground
VREFN	13	Analog Input	Negative reference input
VREFP	14	Analog Input	Positive reference input
AVDD	15	Analog	Analog power supply
DVDD	16	Digital	Digital power supply

### TYPICAL CHARACTERISTICS

At  $T_A = +25^\circ\text{C}$ ,  $AVDD = +5\text{V}$ ,  $DVDD = +3\text{V}$ , and  $V_{REF} = +5\text{V}$ , unless otherwise noted.

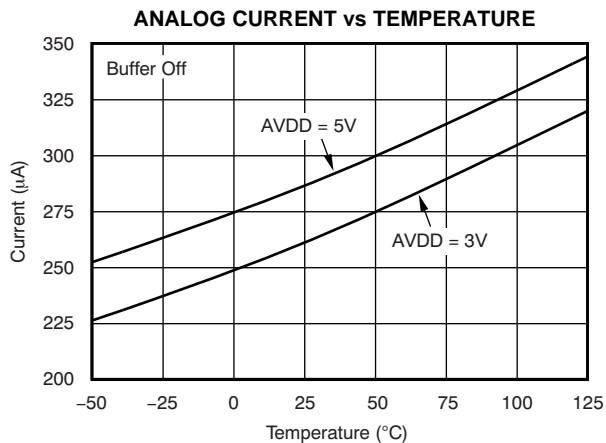

Figure 1.

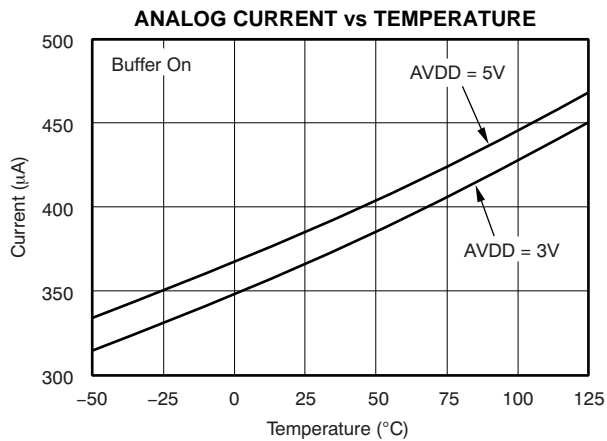

Figure 2.

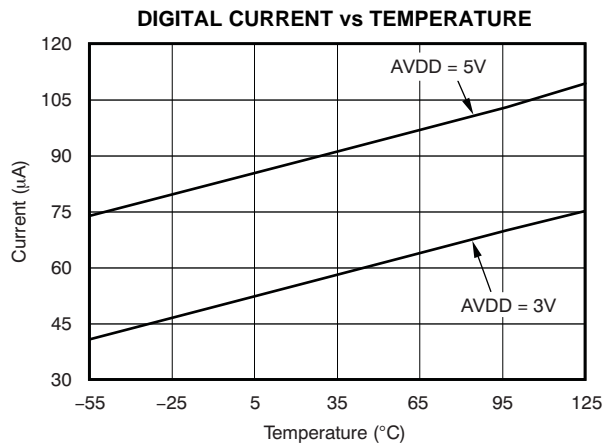

Figure 3.

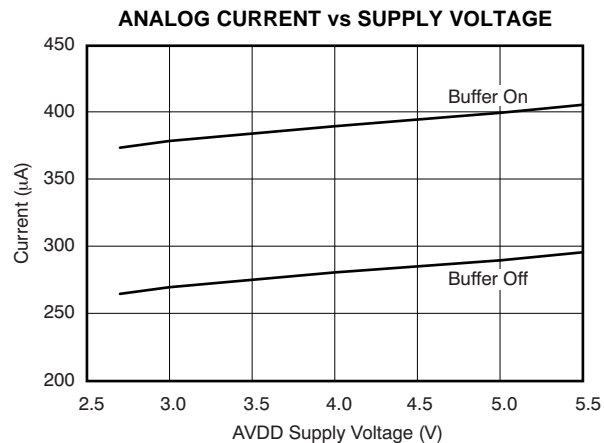

Figure 4.

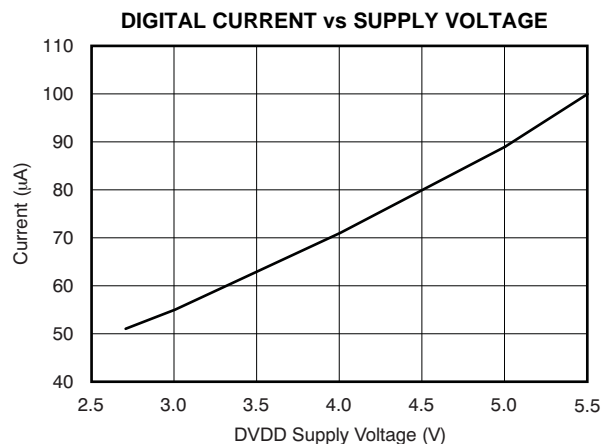

Figure 5.

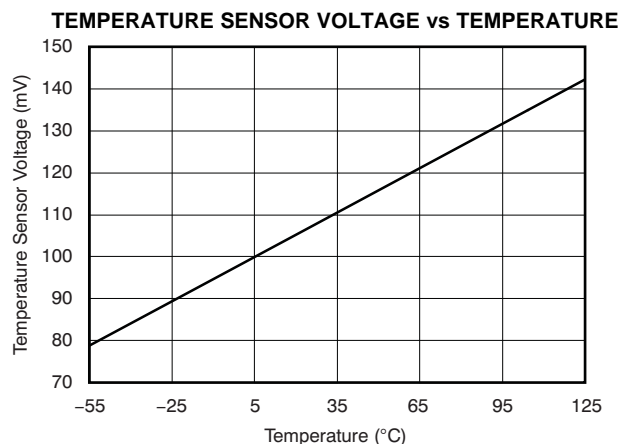

Figure 6.

**TYPICAL CHARACTERISTICS (continued)**

At  $T_A = +25^\circ\text{C}$ ,  $AV_{DD} = +5\text{V}$ ,  $DV_{DD} = +3\text{V}$ , and  $V_{REF} = +5\text{V}$ , unless otherwise noted.

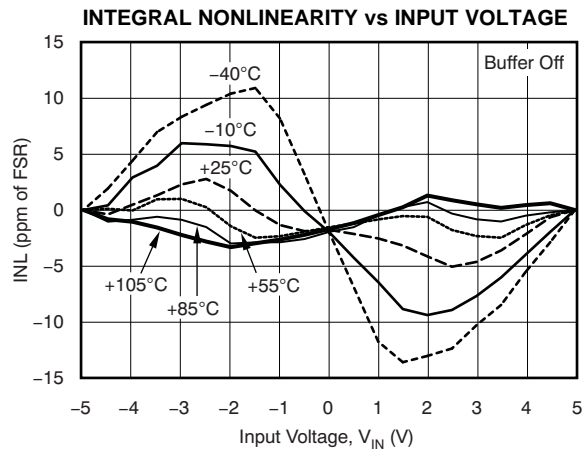

Figure 7.

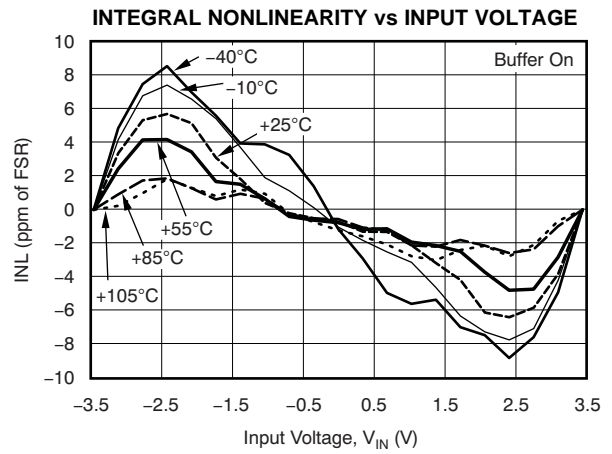

Figure 8.

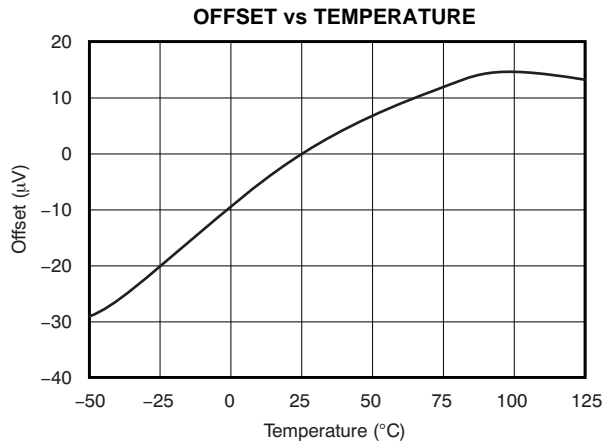

Figure 9.

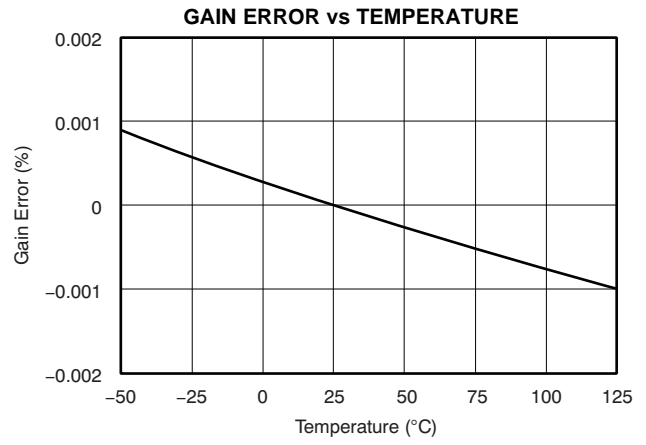

Figure 10.

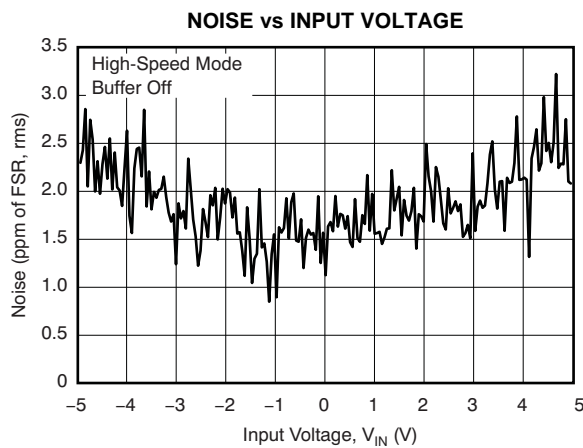

Figure 11.

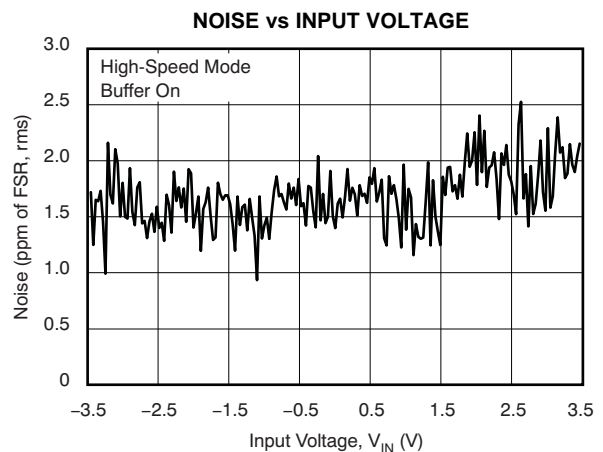
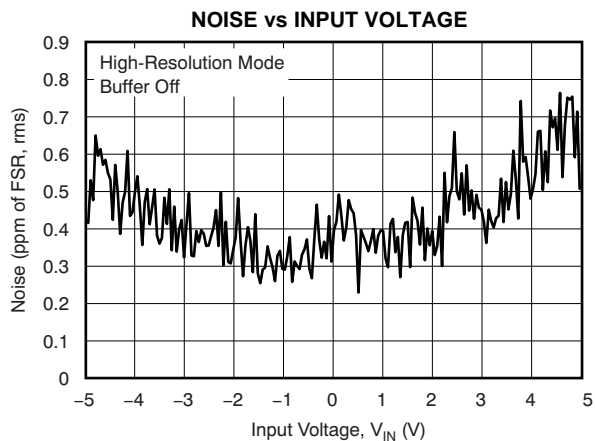

Figure 12.

**TYPICAL CHARACTERISTICS (continued)**

At  $T_A = +25^\circ\text{C}$ ,  $AV_{DD} = +5\text{V}$ ,  $DV_{DD} = +3\text{V}$ , and  $V_{REF} = +5\text{V}$ , unless otherwise noted.



**Figure 13.**

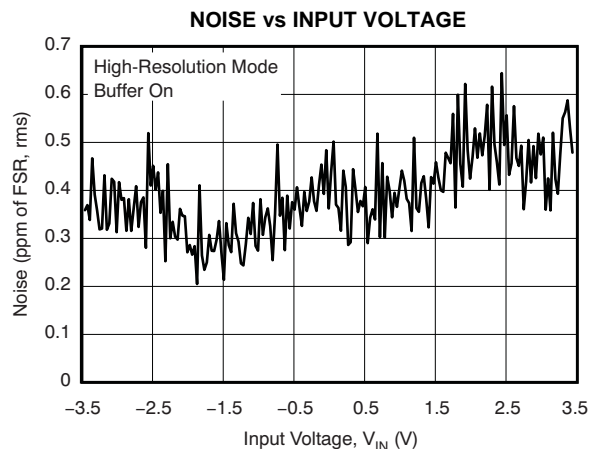

**Figure 14.**

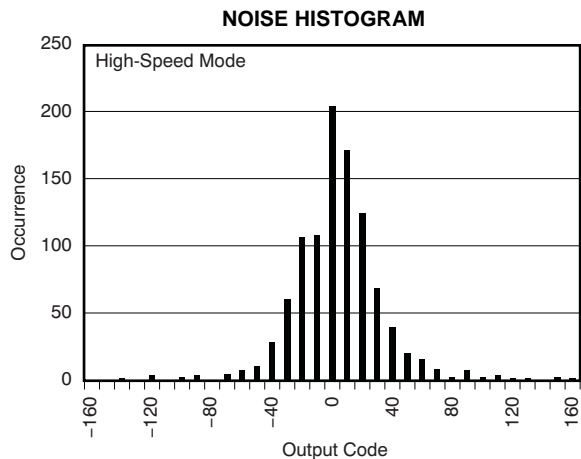

**Figure 15.**

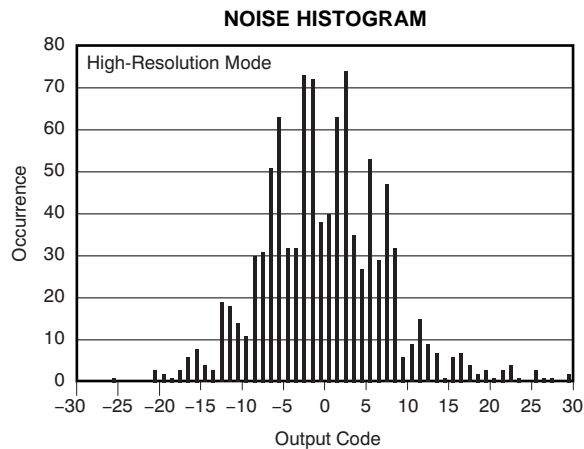

**Figure 16.**

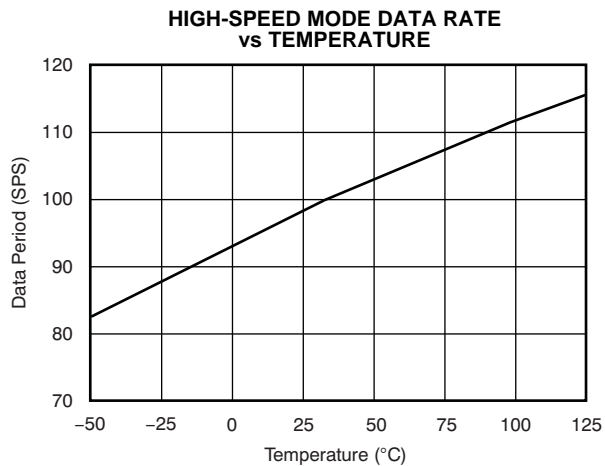

**Figure 17.**

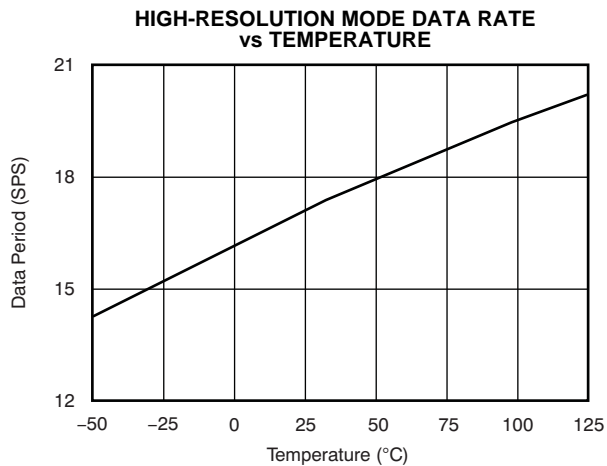

**Figure 18.**

## OVERVIEW

The ADS1225 and ADS1226 are 24-bit delta-sigma A/D converters. Figure 19 shows a conceptual diagram of the device. The ADS1225 has a single channel, while the ADS1226 allows for one of two input channels to be selected through a multiplexer. A buffer can also be selected to increase the input impedance. The modulator measures the differential input signal  $V_{IN} = (A_{INP} - A_{INN})$  against the differential reference  $V_{REF} = (V_{REFP} - V_{REFN})$ . The full-scale input range is  $\pm V_{REF}$ . A 2-wire serial interface indicates conversion completion and provides the user with the output data. An internal oscillator allows for free-running of the ADS1225 and ADS1226.

Two other pins are used to control the operation of the ADS1225 and ADS1226. The START pin initiates conversions. The MODE pin puts the device into one of two modes. In High-Speed mode, the device gives data at 100 samples per second (SPS). In High-Resolution mode, data comes out at 16SPS with lower noise. In both modes, the device has single-cycle settling, reducing the latency of the output data.

## ANALOG INPUTS (AINx+, AINx-)

The input signal to be measured is applied to the input pins AINPx and AINNx. The positive internal input is generalized as AINP, and the negative internal input is generalized as AINN. The signal is selected through the input MUX, which is controlled by MUX, as shown in Table 1. The ADS1225 and ADS1226 accept differential input signals, but can also measure unipolar signals. When measuring unipolar (or single-ended) signals with respect to ground, connect the negative input (AINN) to ground and connect the input signal to the positive input (AINP). Note that when the ADS1225 and ADS1226 are configured this way, only half of the converter full-scale range is used since only positive digital output codes are produced. An input buffer can be selected to increase the input impedance of the A/D converter with the BUFEN pin.

Table 1. Input Channel Selection with MUX

DIGITAL PIN	SELECTED ANALOG INPUTS	
MUX	POSITIVE INPUT	NEGATIVE INPUT
0	AINP1	AINN1
1	AINP2	AINN2

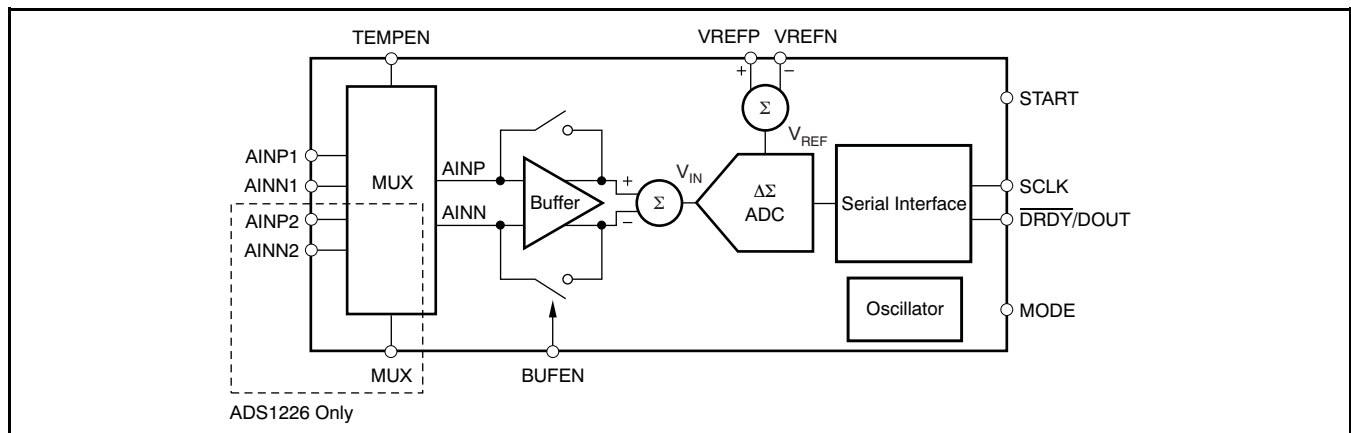

Figure 19. Conceptual Diagram of the ADS1225 and ADS1226

### Analog Input Measurement Without the Input Buffer

With the buffer disabled by setting the BUFEN pin low, the ADS1225 and ADS1226 measure the input signal using internal capacitors that are continuously charged and discharged. Figure 20 shows a simplified schematic of the ADS1225/6 input circuitry, with Figure 21 showing the on/off timings of the switches. The  $S_1$  switches close during the input sampling phase. With  $S_1$  closed,  $C_{A1}$  charges to AINP,  $C_{A2}$  charges to AINN, and  $C_B$  charges to (AINP – AINN). For the discharge phase,  $S_1$  opens first and then  $S_2$  closes.  $C_{A1}$  and  $C_{A2}$  discharge to approximately VDD/2 and  $C_B$  discharges to 0V. The constant charging of the input capacitors presents a load on the inputs that can be represented by effective impedances. Figure 22 shows the input circuitry with the capacitors and switches of Figure 20 by their effective impedances.

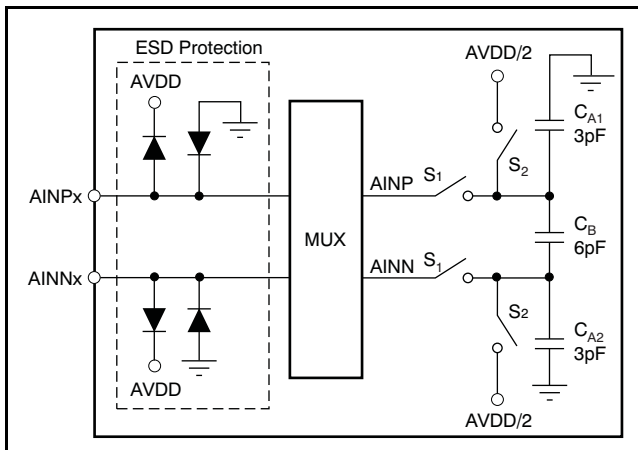

Figure 20. Simplified Input Structure with the Buffer Turned Off

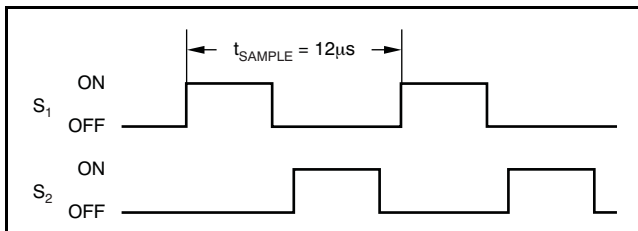

Figure 21.  $S_1$  and  $S_2$  Switch Timing for Figure 20

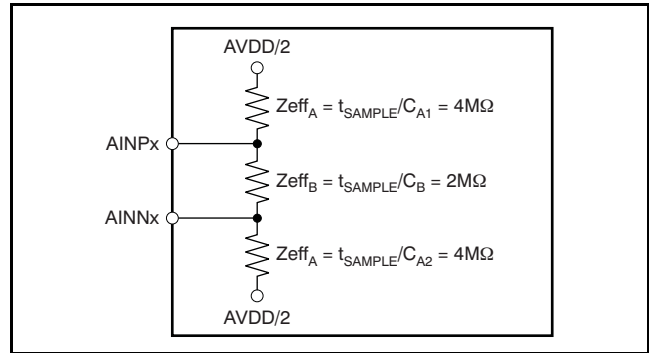

Figure 22. Effective Analog Input Impedances with the Buffer Off

ESD diodes protect the inputs. To keep these diodes from turning on, make sure the voltages on the input pins do not go below GND by more than 100mV, and likewise do not exceed VDD by 100mV. This limitation is shown in Equation 1:

$$GND - 100mV < (AINP, AINN) < VDD + 100mV \quad (1)$$

### Analog Input Measurement with the Input Buffer

When the buffer is enabled by setting the BUFEN pin high, a low-drift, chopper-stabilized input buffer is used to achieve very high input impedance. The buffer charges the input sampling capacitors, thus removing the load from the measurement. Because the input buffer is chopper-stabilized, the charging of parasitic capacitances causes the charge to be carried away, as if by resistance. The input impedance can be modeled by a single resistor, as shown in Figure 23. Note that when START is low, the buffer must be disabled to prevent loading of the inputs.

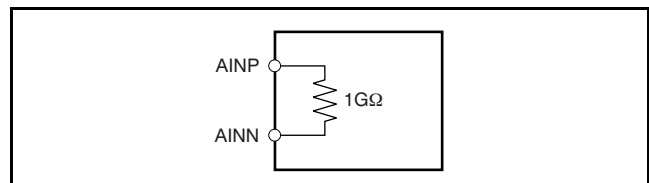

Figure 23. Effective Analog Input Impedances with the Buffer On

Note also that the analog inputs (listed in the Electrical Characteristics table as *Absolute Input Range*) must remain between GND + 0.05V to AVDD – 1.5V. Exceeding this range degrades linearity and results in performance outside the specified limits.

## TEMPERATURE SENSOR

Internal diodes provide temperature-sensing capability. By setting the TEMPEN pin high, the selected analog inputs are disconnected and the inputs to the A/D converter are connected to the anodes of two diodes scaled to 1x and 64x in current and size inside the MUX, as shown in Figure 24. By measuring the difference in voltage of these diodes, temperature changes can be inferred from a baseline temperature. Typically, the difference in diode voltages is 106mV at +25°C, with a temperature coefficient of 360μV/°C. A similar structure is used in the MSC1210 for temperature measurement. For more information, see TI application report SBAA100, *Using the MSC121x as a High-Precision Intelligent Temperature Sensor*, available for download at [www.ti.com](http://www.ti.com).

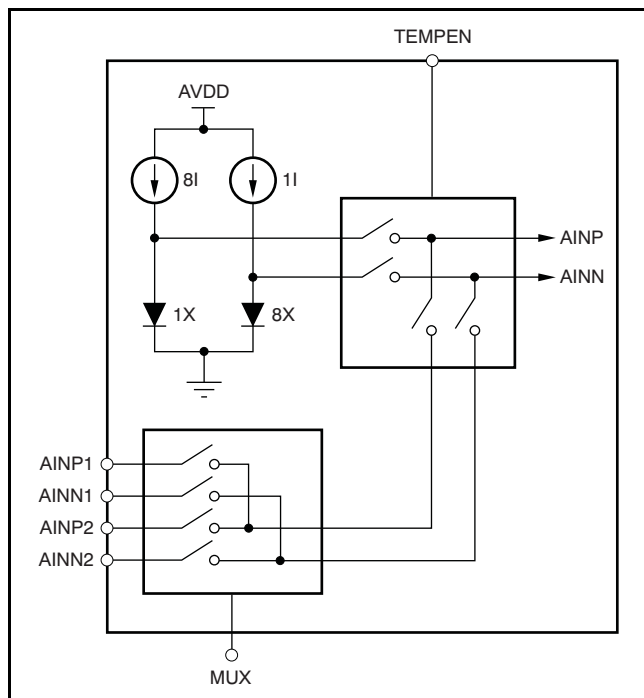

Figure 24. Measurement of the Temperature Sensor in the Input

## VOLTAGE REFERENCE INPUTS (VREFP, VREFN)

The voltage reference used by the modulator is generated from the voltage difference between VREFP and VREFN:  $V_{REF} = VREFP - VREFN$ . The reference inputs use a structure similar to that of the analog inputs. A simplified diagram of the circuitry on the reference inputs is shown in Figure 25. The switches and capacitors can be modeled with an effective impedance of 1.5MΩ.

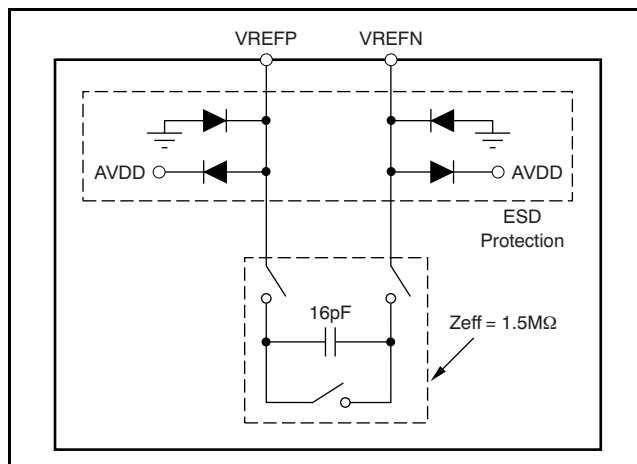

Figure 25. Simplified Reference Input Circuitry

ESD diodes protect the reference inputs. To prevent these diodes from turning on, make sure the voltages on the reference pins do not go below GND by more than 100mV, and likewise, do not exceed VDD by 100mV. This limitation is shown in Equation 2:

$$GND - 100mV < (VREFP, VREFN) < VDD + 100mV \quad (2)$$

For best performance, bypass the voltage reference inputs with a 0.1μF capacitor between VREFP and VREFN. Place the capacitor as close as possible to the pins.

The differential voltage reference inputs and the wide range of operation ( $V_{REF}$  can support up to AVDD) make ratiometric measurements easy to implement.

## INTERNAL OSCILLATOR

The ADS1225 and ADS1226 have an internal oscillator and run without an external crystal or oscillator.

## DATA READY/DATA OUTPUT ( $\overline{\text{DRDY}}/\text{DOUT}$ )

This digital output pin serves two purposes. First, it indicates when new data is ready by going LOW. Afterwards, on the first rising edge of SCLK, the  $\overline{\text{DRDY}}/\text{DOUT}$  pin changes function and begins to output the conversion data, most significant bit (MSB) first. Data is shifted out on each subsequent SCLK rising edge. After all 24 bits have been retrieved, the pin can be forced high with an additional SCLK. It then stays high until new data is ready. This configuration is useful when polling on the status of  $\overline{\text{DRDY}}/\text{DOUT}$  to determine when to begin data retrieval.

## SERIAL CLOCK INPUT (SCLK)

This digital input shifts serial data out with each rising edge. There is hysteresis built into this input, but care should still be taken to ensure a clean signal. Glitches or slow-rising signals can cause unwanted additional shifting. For this reason, it is best to make sure the rise-and-fall times of SCLK are less than 50ns.

## MODE

The ADS1225 and ADS1226 have two modes of operation, allowing for High-Speed or High-Resolution. By taking the MODE pin high, the data rate is approximately 100Hz with an rms noise of 15 $\mu$ V. When the MODE pin is low, the ADS1225 and ADS1226 average multiple samples to increase the noise performance to 4 $\mu$ V of rms noise with a data rate of 16Hz. Table 2 shows the MODE pin operation.

**Table 2. MODE Pin Operation for the ADS1225 and ADS1226**

MODE PIN	MODE	DATA RATE	NOISE
0	High-Resolution	16SPS	4 $\mu$ Vrms
1	High-Speed	100SPS	15 $\mu$ Vrms

## START

The START pin provides easy and precise control of conversions. Pulse the START pin high to begin a conversion as shown in Figure 26 and Table 3. The completion of the conversion is indicated by the  $\overline{\text{DRDY}}/\text{DOUT}$  pin going low. Once the conversion completes, the ADS1225 and ADS1226 automatically shut down to save power. They stay shut down until START is once again taken high to begin a new conversion.

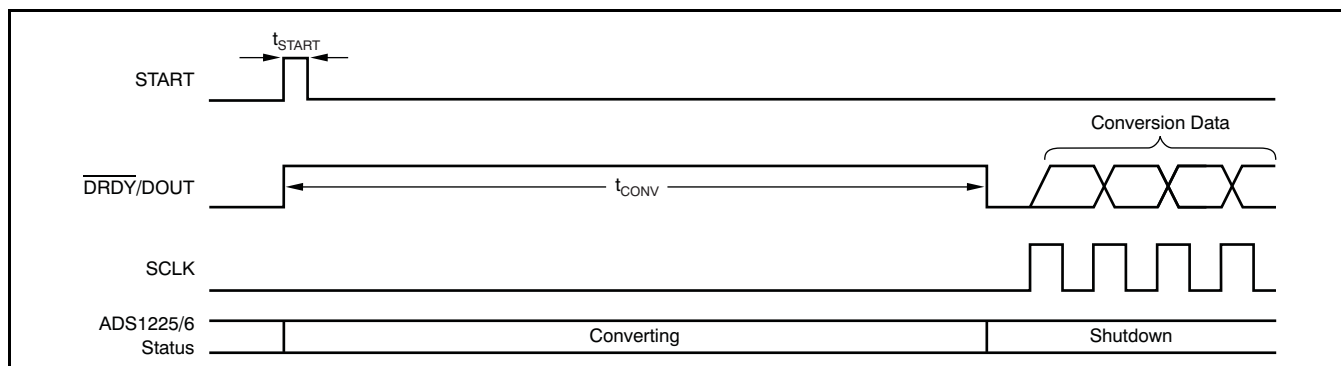

**Figure 26. Controlling Conversion with the START Pin**

**Table 3. START Pin Conversion Times for Figure 26**

SYMBOL	DESCRIPTION	MIN	MAX	UNITS
$t_{\text{START}}$	Minimum START pulse to initiate a conversion	17		$\mu$ s
$t_{\text{CONV}}$	Conversion time High-Speed mode	8.0	13.3	ms
	Conversion time High-Resolution mode	45.5	83.3	ms

The ADS1225 and ADS1226 can be configured to continuously convert by holding the START pin high as shown in Figure 27. With START held high, a new conversion starts immediately after the previous conversion completes. This configuration continues until the START pin is taken low. During calibration, the START pin must be kept high. Refer to the [Self-Calibration](#) section for details. Note that when START is low, the buffer must be disabled to prevent loading of the inputs.

**DATA FORMAT**

The ADS1225 and ADS1226 output 24 bits of data in binary two's complement format. The least significant bit (LSB) has a weight of  $(V_{REF})/(2^{23} - 1)$ . The positive full-scale input produces an output code of 7FFFFFFh and the negative full-scale input produces an output code of 800000h. The output clips at these codes for signals exceeding full-scale. Table 4 summarizes the ideal output codes for different input signals.

**Table 4. Ideal Output Code vs Input Signal**

Input Signal $V_{IN}$ (AINP – AINN)	IDEAL OUTPUT CODE <sup>(1)</sup>
$\geq +V_{REF}$	7FFFFFFh
$\frac{+V_{REF}}{2^{23} - 1}$	000001h
0	000000h
$\frac{-V_{REF}}{2^{23} - 1}$	FFFFFFh
$\leq -V_{REF}$	800000h

(1) Excludes effects of noise, INL, offset, and gain errors.

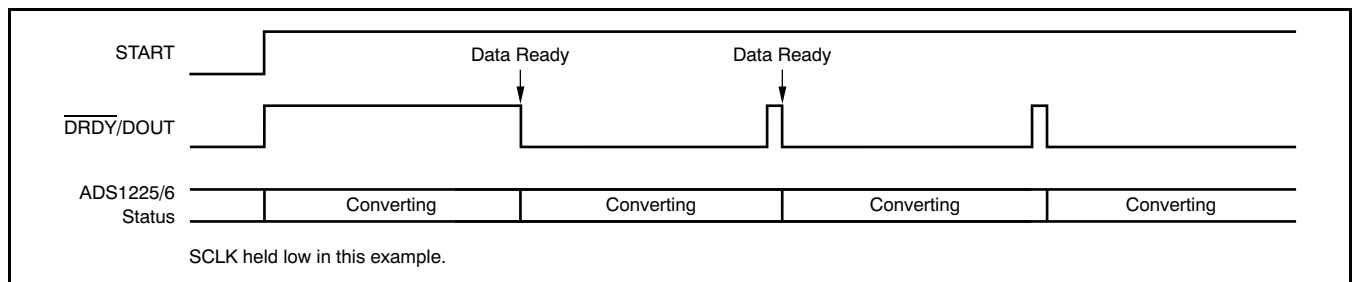

**Figure 27. Conversion with the START Pin High**

## DATA RETRIEVAL

With the START pin high, the ADS1225 and ADS1226 continuously convert the analog input signal. To retrieve data, wait until  $\overline{\text{DRDY}}/\text{DOUT}$  goes low, as illustrated in Figure 28 and Table 5. After this occurs, begin shifting out the data by applying SCLKs. Data is shifted out MSB first. It is not required to shift out all 24 bits of data, but the data must be retrieved before the new data is updated (see  $t_2$ ) or else it will be overwritten.

Avoid data retrieval during the update period.  $\overline{\text{DRDY}}/\text{DOUT}$  remain at the state of the last bit shifted out until it is taken high (see  $t_6$ ), indicating that new data is being updated. To avoid having  $\overline{\text{DRDY}}/\text{DOUT}$  remain in the state of the last bit, shift a 25th SCLK to force  $\overline{\text{DRDY}}/\text{DOUT}$  high (refer to Figure 29). This technique is useful when a host controlling the ADS1225 and ADS1226 is polling  $\overline{\text{DRDY}}/\text{DOUT}$  to determine when data is ready.

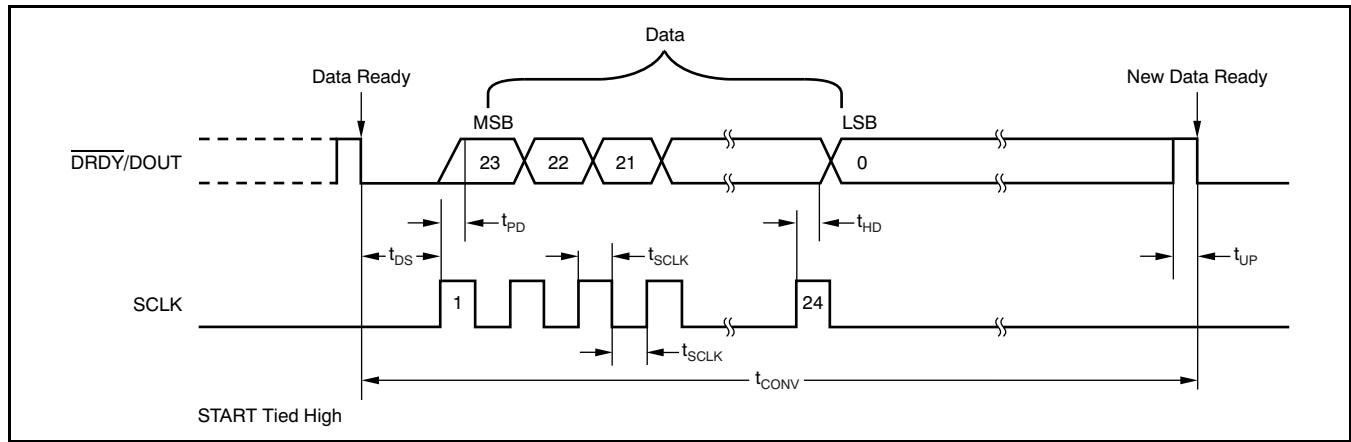

Figure 28. Data Retrieval Timing

Table 5. Data Retrieval Times for Figure 28

SYMBOL	DESCRIPTION	MIN	MAX	UNITS
$t_{DS}$	$\overline{\text{DRDY}}/\text{DOUT}$ low to first SCLK rising edge	0		ns
$t_{SCLK}$	SCLK positive or negative pulse width	100		ns
$t_{PD}$	SCLK rising edge to new data bit valid: propagation delay		50	ns
$t_{HD}$	SCLK rising edge to old data bit valid: hold time	0		ns
$t_{UP}$	Data updating: no readback allowed	29.5	49.2	$\mu\text{s}$
$t_{CONV}$	Conversion time (1/data rate), High-Speed mode	8.0	13.3	ms
	Conversion time (1/data rate), High-Resolution mode	45.5	83.3	ms

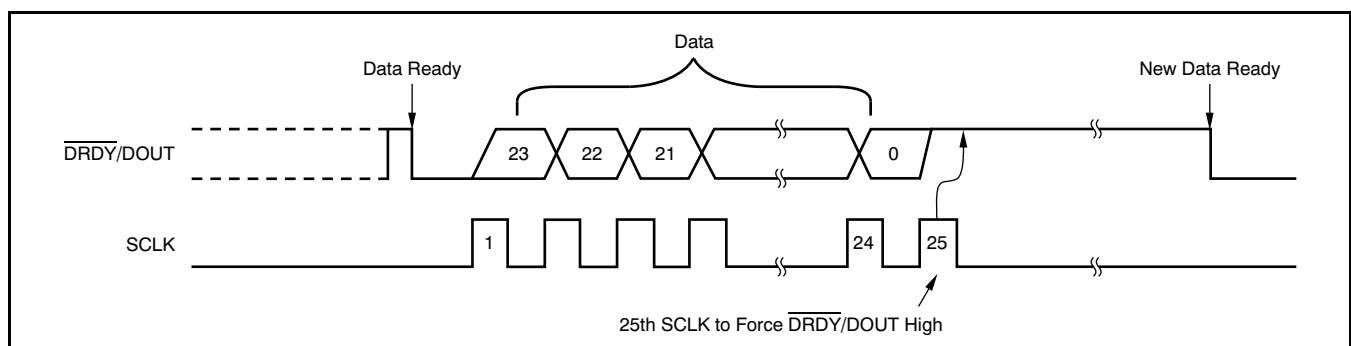

Figure 29. Data Retrieval with  $\overline{\text{DRDY}}/\text{DOUT}$  Forced High Afterwards

### SELF-CALIBRATION

Self-calibration can be initiated at any time by applying two additional SCLKs after retrieving 24 bits of data; however, the START pin must be kept high prior to data conversion and remain high until the calibration completes. Figure 30 and Table 6 illustrate the timing pattern. The 25th SCLK will send  $\overline{\text{DRDY}}/\text{DOUT}$  high. The falling edge of the 26th SCLK will begin the calibration cycle. Additional SCLK pulses may be sent after the 26th SCLK; however, activity on SCLK should be minimized during calibration for best results.

When the calibration is complete,  $\overline{\text{DRDY}}/\text{DOUT}$  goes low, indicating that new data is ready. There is no need to alter the analog input signal applied to the ADS1225 and ADS1226 during calibration; the input pins are disconnected within the A/D converter and the appropriate signals are applied internally and automatically. The first conversion after a calibration is fully settled and valid for use. The time required for a calibration depends on two independent signals: the falling edge of SCLK and an internal clock derived from CLK. Variations in the internal calibration values change the time required for calibration ( $t_{\text{CAL}}$ ) within the range given by the min/max specs.

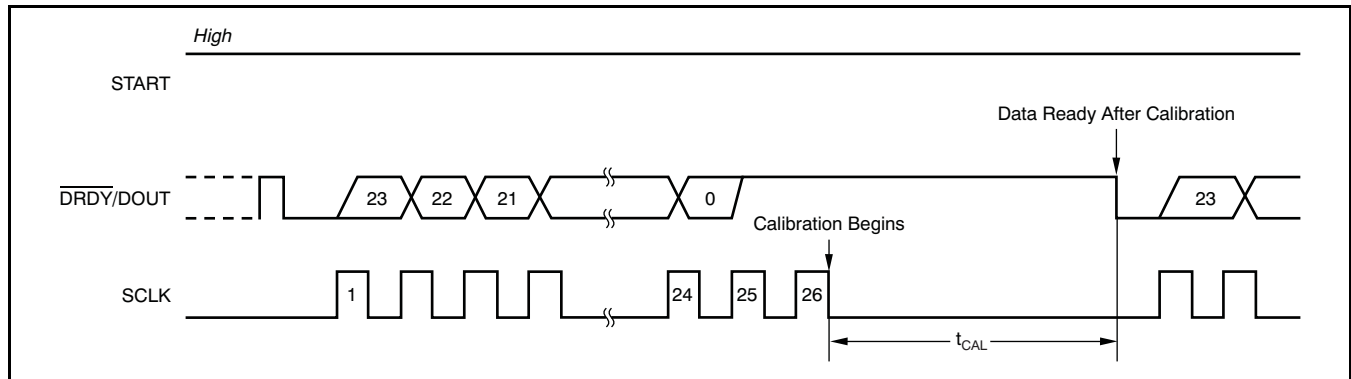

Figure 30. Self-Calibration Timing

Table 6. Self-Calibration Time for Figure 30

SYMBOL	DESCRIPTION	MIN	MAX	UNITS
$t_{\text{CAL}}$	First data ready after calibration	187	313	ms

## APPLICATION INFORMATION

### EXPOSED THERMAL PAD

The exposed thermal pads of the ADS1225 and ADS1226 are internally connected to GND. To protect the package from board stress, solder the exposed thermal pad to the printed circuit board (PCB) and leave it floating electrically. For further information, see Application Report [SLAU271, QFN/SON PCB Attachment](#), available for download from [www.ti.com](#).

### GENERAL RECOMMENDATIONS

The ADS1225 and ADS1226 are high-resolution A/D converters. Achieving optimal device performance requires careful attention to the support circuitry and PCB design. [Figure 31](#) shows the basic connections for the ADS1225 and ADS1226. As with any precision circuit, be sure to use good supply bypassing capacitor techniques. A smaller value ceramic capacitor in parallel with a larger value tantalum capacitor works well. Place the capacitors, in particular the ceramic ones, close to the supply pins. Use a ground plane and tie the ADS1225 and

ADS1226 GND pin and bypass capacitors directly to it. Avoid ringing on the digital inputs. Small resistors ( $\approx 100\Omega$ ) in series with the digital pins can help by controlling the trace impedance. Place these resistors at the source end.

Pay special attention to the reference and analog inputs. These inputs are critical to performance. Bypass the voltage reference using similar techniques to the supply voltages. The quality of the reference directly affects the overall accuracy of the device. Make sure to use a low noise and low drift reference such as the [REF1004](#). Often, only a simple RC filter is needed on the inputs. The circuit limits the higher frequency noise. Avoid low-grade dielectrics for the capacitors and place them as close as possible to the input pins. Keep the traces to the input pins short, and carefully watch how they are routed on the PCB.

After the power supplies and reference voltage have stabilized, issue a self-calibration command to minimize offset and gain errors.

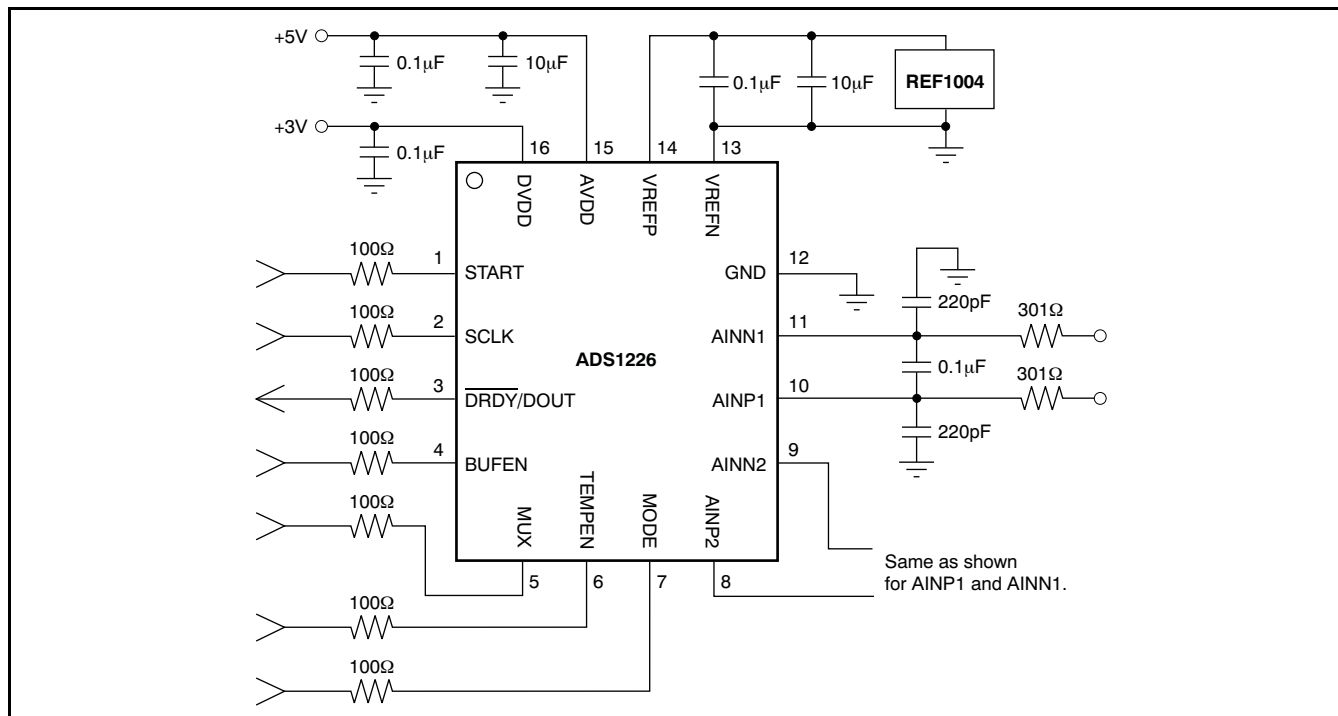

Figure 31. Basic Connections

### SMALL INPUT SIGNALS

Figure 32 shows the schematic of the ADS1225 for measuring small output signals such as the output of a bridge sensor or load cell. In this application, the load cell is combined with the ADS1225 and an MSP430 microcontroller. An OPA2333 is used to buffer the inputs and to provide the gain of the load cell signal. A 5V source is used as the reference and the excitation, although any clean source can create a proper ratiometric signal for the reference.

A typical load cell with a bridge sensitivity of 2mV/V using a 5V source would have a full-scale output of 10mV. The recommended gain of the OPA2333, for this load cell using low-drift resistors, would be  $1 + 2R_F/R_G = 100.8V/V$ . This value gives a full-scale

measurement of approximately 1V while keeping the noise contribution of the OPA2333 low. The noise is low enough compared to full-scale to create a several-thousand count weigh scale, even in High-Speed mode. For better accuracy, this noise could be lowered through either additional filtering or using the High-Resolution mode.

It is important to make sure that the reference and inputs are clean from clocks or other periodic signals to prevent coupling. Isolate the analog from the digital supplies and grounds whenever possible.

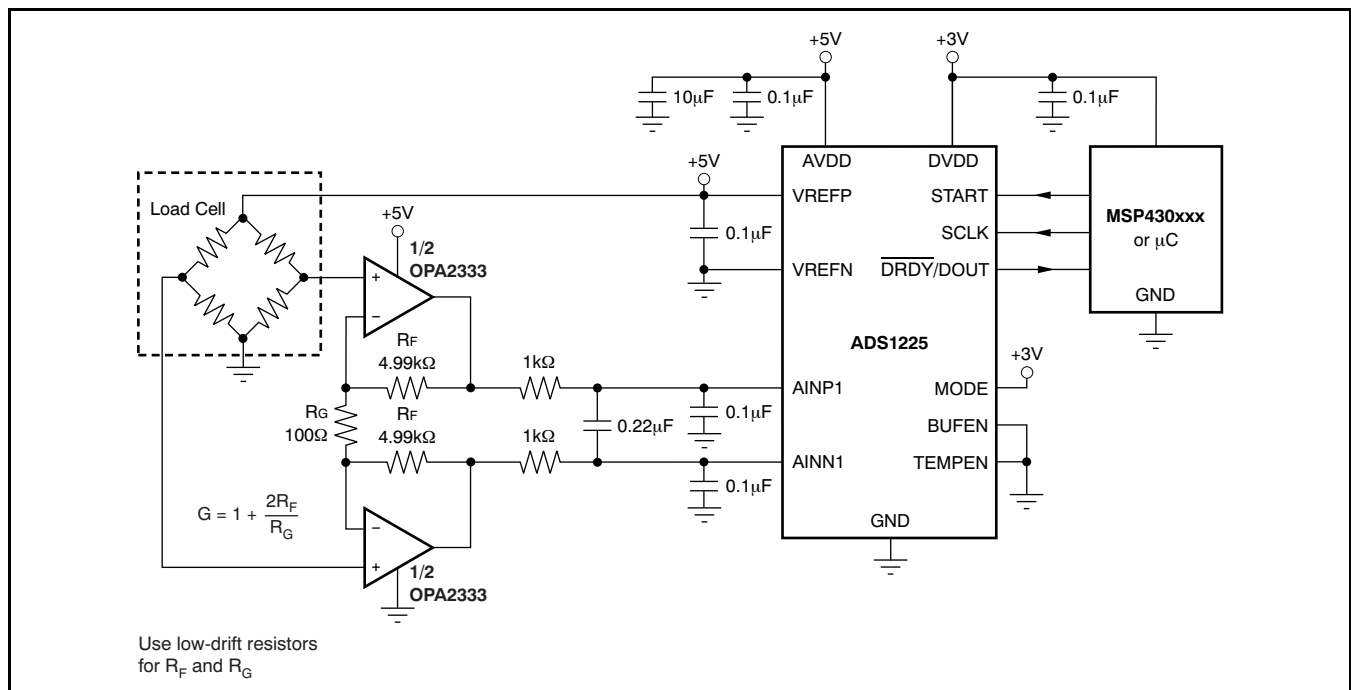

Figure 32. Using the OPA2333 as a Gain Stage in Front of the ADS1225

## LARGE INPUT SIGNALS

Many industrial applications require measurement of signals that go beyond 5V. The ADS1225 can be used to measure large input signals with the help of an INA159. The precision, level translation differential amplifier converts a  $\pm 10V$  input to a 5V input scale. This design allows systems to be run from a single 5V supply without the need for higher voltage supplies for signal conditioning.

Figure 33 shows a basic schematic. The negative input of the INA159 is grounded while the positive input is allowed to swing from  $-10V$  to  $+10V$ . Similarly, the negative input of the ADS1225 is grounded while the positive input swings from  $0.5V$  to  $+4.5V$  given the useful  $V_{OUT}$  swing of the INA159. The larger signal is easily measured without the need for extra  $\pm 10V$  supplies. See the [INA159](#) data sheet for additional details.

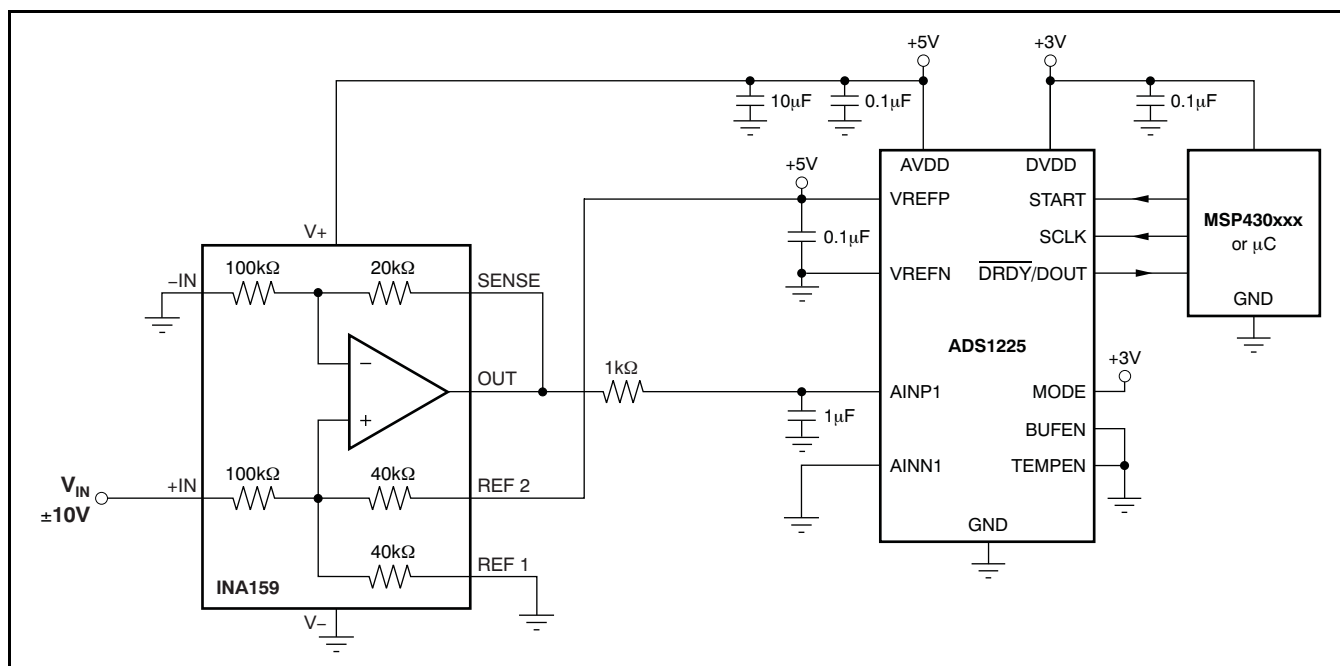

Figure 33. With the Help of an INA159, the ADS1225 Measures  $\pm 10V$  Signals

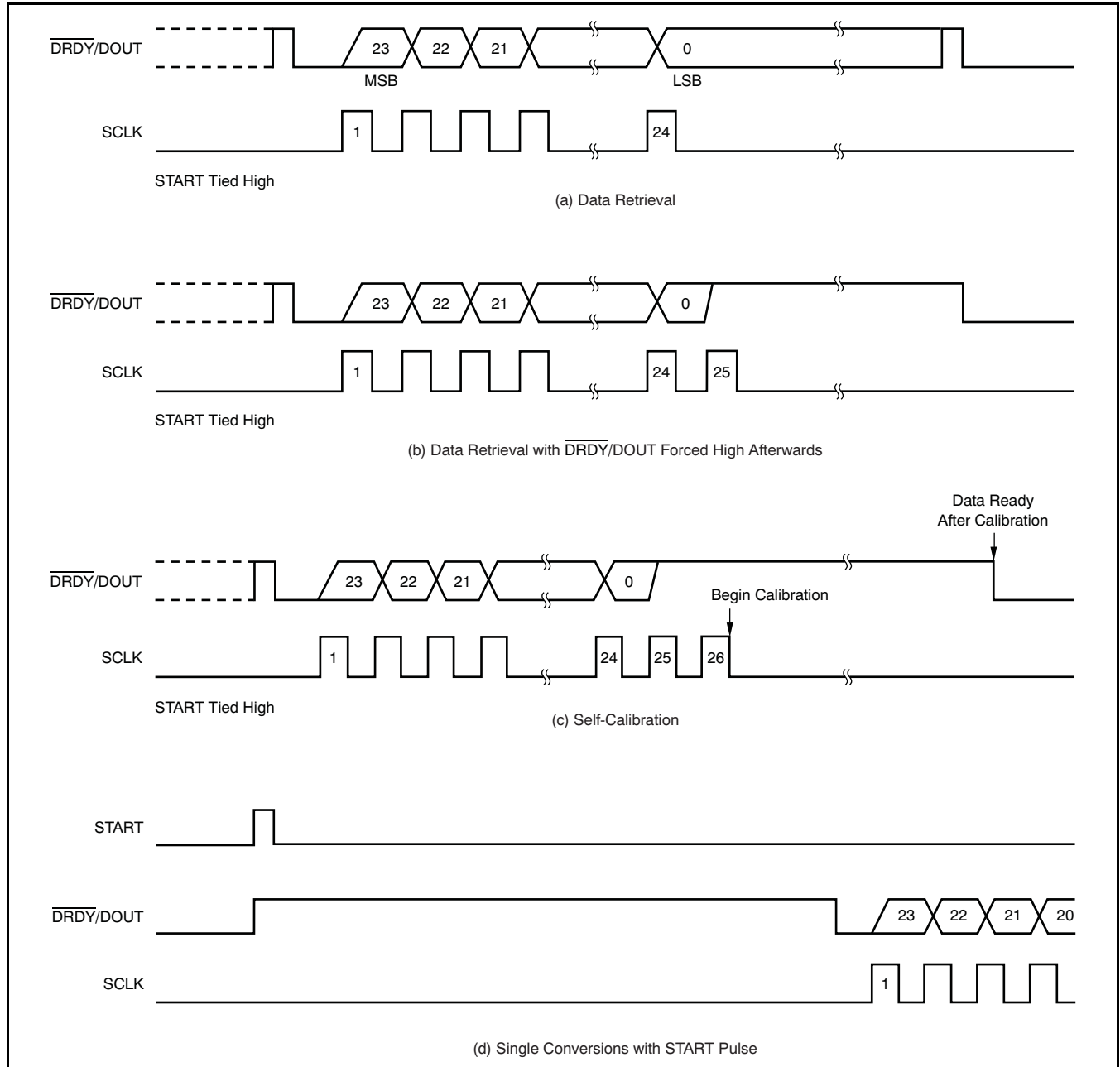

Figure 34. Summary of Serial Interface Waveforms

Table 7. Digital Pin Operations

DIGITAL PIN	PIN NO.	INPUT	
		0	1
START	1	Shutdown Mode	Start Conversion
BUFEN	4	Buffer Off	Buffer On
MUX (ADS1226 only)	5	AINP1 – AINN1 Input	AINP2 – AINN2 Input
TEMPEN	6	Temperature Sensor Off	Temperature Sensor On
MODE	7	High-Resolution Mode	High-Speed Mode

## Revision History

<b>Changes from Revision B (August 2007) to Revision C</b>	<b>Page</b>
<ul style="list-style-type: none"> <li>• Added last sentence to first paragraph of <i>Analog Input Measurement with the Input Buffer</i> section describing the START mode ..... 11</li> <li>• Added last sentence to second paragraph of <i>Start</i> section describing the START mode ..... 14</li> </ul>	
<b>Changes from Revision A (April 2007) to Revision B</b>	<b>Page</b>
<ul style="list-style-type: none"> <li>• Changed effective impedance from 250kΩ to 1.5MΩ in last sentence of <i>Voltage Reference Inputs</i> section ..... 12</li> <li>• Changed <a href="#">Figure 25</a> ..... 12</li> <li>• Added text to end of <i>START</i> section regarding keeping the START pin high during calibration ..... 14</li> <li>• Changed <a href="#">Figure 27</a> title ..... 14</li> <li>• Changed text in first paragraph of <i>Self-Calibration</i> section ..... 16</li> <li>• Changed <a href="#">Figure 30</a> ..... 16</li> </ul>	

## PACKAGING INFORMATION

Orderable Device	Status (1)	Package Type	Package Drawing	Pins	Package Qty	Eco Plan (2)	Lead/Ball Finish (6)	MSL Peak Temp (3)	Op Temp (°C)	Device Marking (4/5)	Samples
ADS1225IRGVR	ACTIVE	VQFN	RGV	16	2500	Green (RoHS & no Sb/Br)	CU NIPDAU	Level-2-260C-1 YEAR	-40 to 105	ADS 1225	<a href="#">Samples</a>
ADS1225IRGVT	ACTIVE	VQFN	RGV	16	250	Green (RoHS & no Sb/Br)	CU NIPDAU	Level-2-260C-1 YEAR	-40 to 105	ADS 1225	<a href="#">Samples</a>
ADS1226IRGVR	ACTIVE	VQFN	RGV	16	2500	Green (RoHS & no Sb/Br)	CU NIPDAU	Level-2-260C-1 YEAR	-40 to 105	ADS 1226	<a href="#">Samples</a>
ADS1226IRGVRG4	ACTIVE	VQFN	RGV	16	2500	Green (RoHS & no Sb/Br)	CU NIPDAU	Level-2-260C-1 YEAR	-40 to 105	ADS 1226	<a href="#">Samples</a>
ADS1226IRGVT	ACTIVE	VQFN	RGV	16	250	Green (RoHS & no Sb/Br)	CU NIPDAU	Level-2-260C-1 YEAR	-40 to 105	ADS 1226	<a href="#">Samples</a>

(1) The marketing status values are defined as follows:

**ACTIVE:** Product device recommended for new designs.

**LIFEBUY:** TI has announced that the device will be discontinued, and a lifetime-buy period is in effect.

**NRND:** Not recommended for new designs. Device is in production to support existing customers, but TI does not recommend using this part in a new design.

**PREVIEW:** Device has been announced but is not in production. Samples may or may not be available.

**OBsolete:** TI has discontinued the production of the device.

(2) **RoHS:** TI defines "RoHS" to mean semiconductor products that are compliant with the current EU RoHS requirements for all 10 RoHS substances, including the requirement that RoHS substance do not exceed 0.1% by weight in homogeneous materials. Where designed to be soldered at high temperatures, "RoHS" products are suitable for use in specified lead-free processes. TI may reference these types of products as "Pb-Free".

**RoHS Exempt:** TI defines "RoHS Exempt" to mean products that contain lead but are compliant with EU RoHS pursuant to a specific EU RoHS exemption.

**Green:** TI defines "Green" to mean the content of Chlorine (Cl) and Bromine (Br) based flame retardants meet JS709B low halogen requirements of <=1000ppm threshold. Antimony trioxide based flame retardants must also meet the <=1000ppm threshold requirement.

(3) MSL, Peak Temp. - The Moisture Sensitivity Level rating according to the JEDEC industry standard classifications, and peak solder temperature.

(4) There may be additional marking, which relates to the logo, the lot trace code information, or the environmental category on the device.

(5) Multiple Device Markings will be inside parentheses. Only one Device Marking contained in parentheses and separated by a "-" will appear on a device. If a line is indented then it is a continuation of the previous line and the two combined represent the entire Device Marking for that device.

(6) Lead/Ball Finish - Orderable Devices may have multiple material finish options. Finish options are separated by a vertical ruled line. Lead/Ball Finish values may wrap to two lines if the finish value exceeds the maximum column width.

**Important Information and Disclaimer:** The information provided on this page represents TI's knowledge and belief as of the date that it is provided. TI bases its knowledge and belief on information provided by third parties, and makes no representation or warranty as to the accuracy of such information. Efforts are underway to better integrate information from third parties. TI has taken and continues to take reasonable steps to provide representative and accurate information but may not have conducted destructive testing or chemical analysis on incoming materials and chemicals. TI and TI suppliers consider certain information to be proprietary, and thus CAS numbers and other limited information may not be available for release.

In no event shall TI's liability arising out of such information exceed the total purchase price of the TI part(s) at issue in this document sold by TI to Customer on an annual basis.

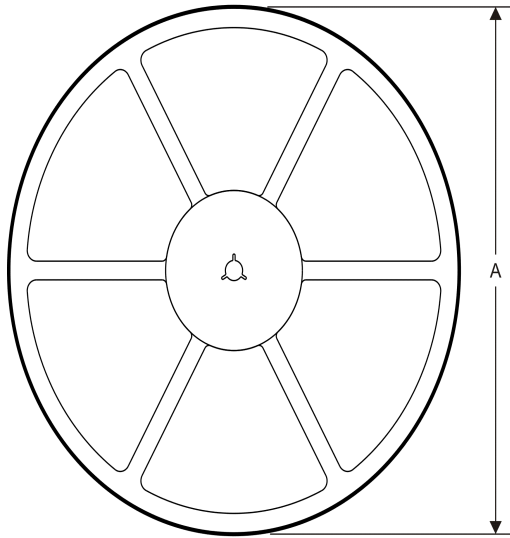
**TAPE AND REEL INFORMATION**
**REEL DIMENSIONS**

**TAPE DIMENSIONS**

A0	Dimension designed to accommodate the component width
B0	Dimension designed to accommodate the component length
K0	Dimension designed to accommodate the component thickness
W	Overall width of the carrier tape
P1	Pitch between successive cavity centers

**TAPE AND REEL INFORMATION**

\*All dimensions are nominal

Device	Package Type	Package Drawing	Pins	SPQ	Reel Diameter (mm)	Reel Width W1 (mm)	A0 (mm)	B0 (mm)	K0 (mm)	P1 (mm)	W (mm)	Pin1 Quadrant
ADS1225IRGVR	VQFN	RGV	16	2500	330.0	12.4	4.25	4.25	1.15	8.0	12.0	Q2
ADS1225IRGVT	VQFN	RGV	16	250	180.0	12.4	4.25	4.25	1.15	8.0	12.0	Q2
ADS1226IRGVR	VQFN	RGV	16	2500	330.0	12.4	4.25	4.25	1.15	8.0	12.0	Q2
ADS1226IRGVT	VQFN	RGV	16	250	180.0	12.4	4.25	4.25	1.15	8.0	12.0	Q2

**TAPE AND REEL BOX DIMENSIONS**

\*All dimensions are nominal

Device	Package Type	Package Drawing	Pins	SPQ	Length (mm)	Width (mm)	Height (mm)
ADS1225IRGVR	VQFN	RGV	16	2500	367.0	367.0	35.0
ADS1225IRGVT	VQFN	RGV	16	250	210.0	185.0	35.0
ADS1226IRGVR	VQFN	RGV	16	2500	367.0	367.0	35.0
ADS1226IRGVT	VQFN	RGV	16	250	210.0	185.0	35.0

RGV (S-PVQFN-N16)

PLASTIC QUAD FLATPACK NO-LEAD

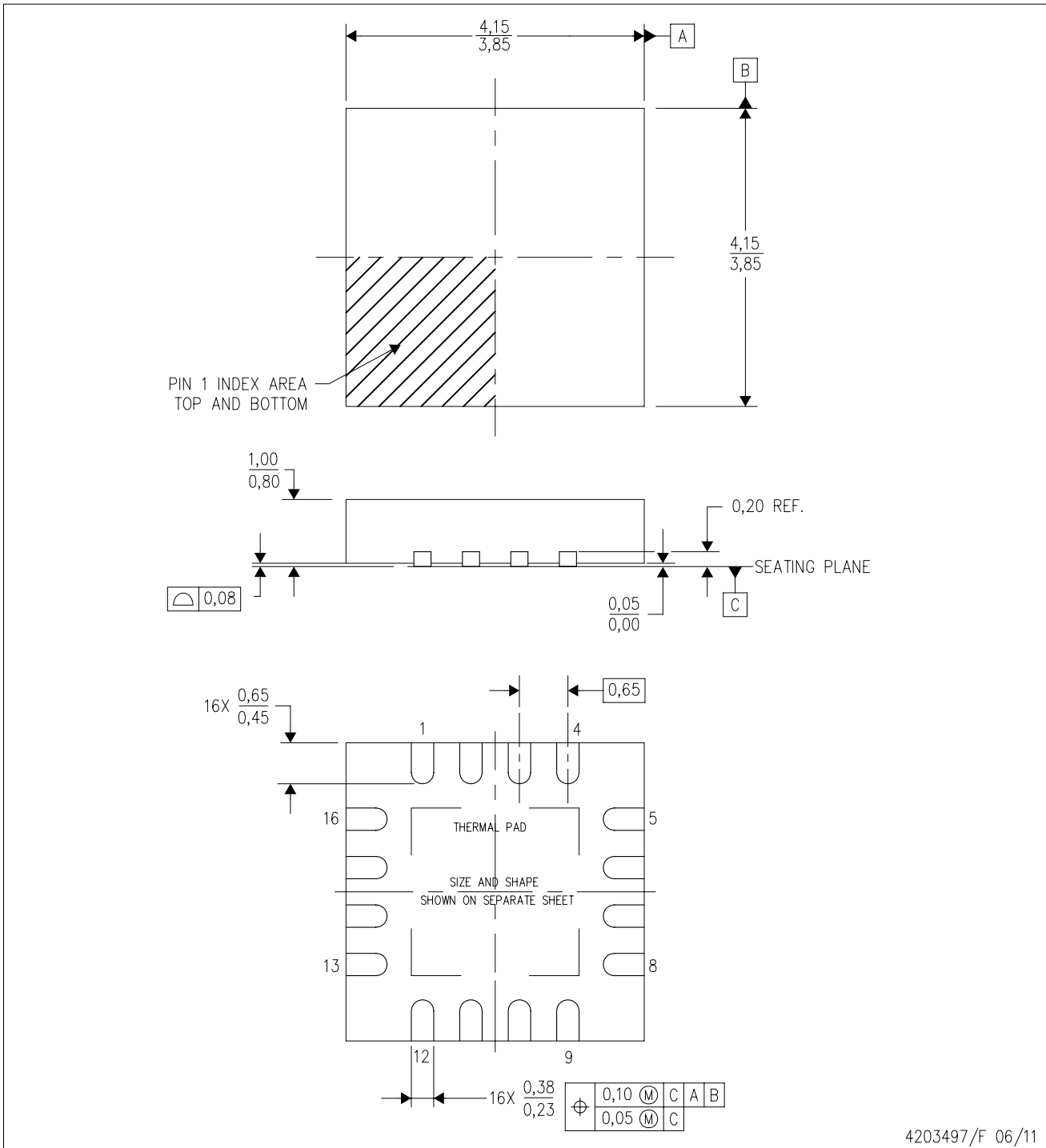

4203497/F 06/11

- NOTES:
- A. All linear dimensions are in millimeters. Dimensioning and tolerancing per ASME Y14.5M-1994.
  - B. This drawing is subject to change without notice.
  - C. Quad Flatpack, No-leads (QFN) package configuration.
  - D. The package thermal pad must be soldered to the board for thermal and mechanical performance.
  - E. See the additional figure in the Product Data Sheet for details regarding the exposed thermal pad features and dimensions.
  - F. Falls within JEDEC MO-220.

# THERMAL PAD MECHANICAL DATA

RGV (S-PVQFN-N16)

PLASTIC QUAD FLATPACK NO-LEAD

## THERMAL INFORMATION

This package incorporates an exposed thermal pad that is designed to be attached directly to an external heatsink. The thermal pad must be soldered directly to the printed circuit board (PCB). After soldering, the PCB can be used as a heatsink. In addition, through the use of thermal vias, the thermal pad can be attached directly to the appropriate copper plane shown in the electrical schematic for the device, or alternatively, can be attached to a special heatsink structure designed into the PCB. This design optimizes the heat transfer from the integrated circuit (IC).

For information on the Quad Flatpack No-Lead (QFN) package and its advantages, refer to Application Report, QFN/SON PCB Attachment, Texas Instruments Literature No. SLUA271. This document is available at [www.ti.com](http://www.ti.com).

The exposed thermal pad dimensions for this package are shown in the following illustration.

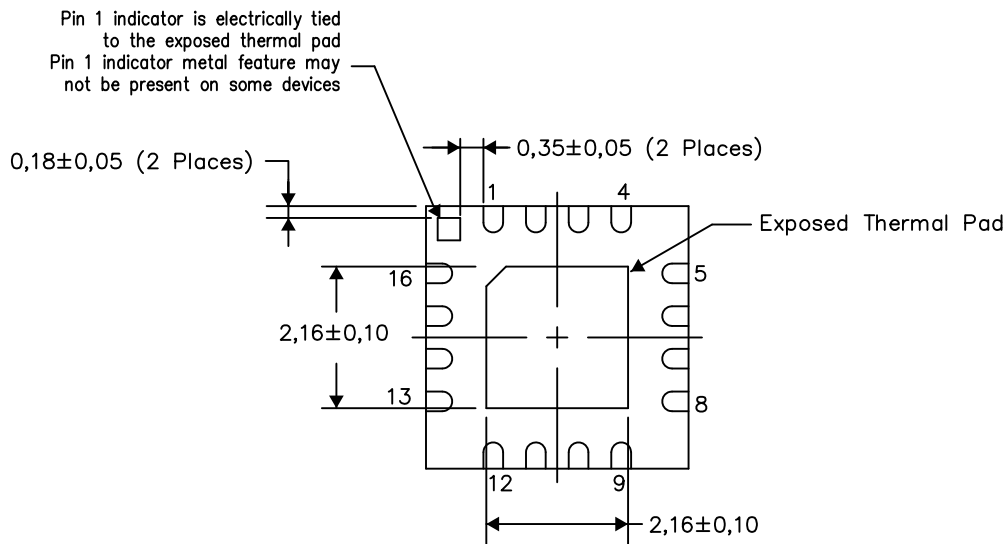

Bottom View

Exposed Thermal Pad Dimensions

4206351-2/L 05/13

NOTE: All linear dimensions are in millimeters

RGV (S-PVQFN-N16)

PLASTIC QUAD FLATPACK NO-LEAD

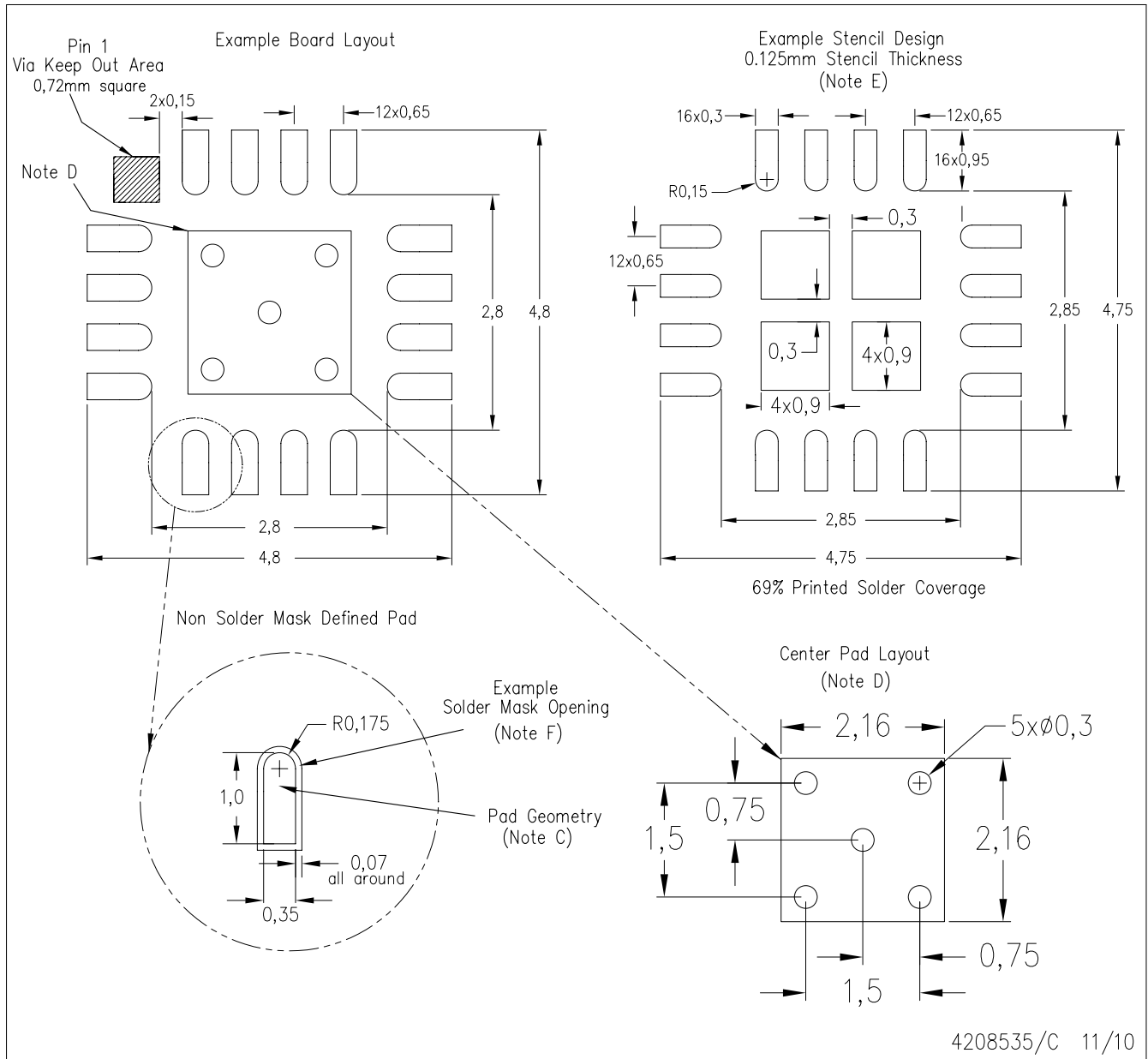

4208535/C 11/10

- NOTES:
- All linear dimensions are in millimeters.
  - This drawing is subject to change without notice.
  - Publication IPC-7351 is recommended for alternate designs.
  - This package is designed to be soldered to a thermal pad on the board. Refer to Application Note, QFN Packages, Texas Instruments Literature No. SLUA271, and also the Product Data Sheets for specific thermal information, via requirements, and recommended board layout. These documents are available at [www.ti.com](http://www.ti.com) <<http://www.ti.com>>.
  - Laser cutting apertures with trapezoidal walls and also rounding corners will offer better paste release. Customers should contact their board assembly site for stencil design recommendations. Refer to IPC 7525 for stencil design considerations.
  - Customers should contact their board fabrication site for solder mask tolerances.

## IMPORTANT NOTICE

Texas Instruments Incorporated (TI) reserves the right to make corrections, enhancements, improvements and other changes to its semiconductor products and services per JESD46, latest issue, and to discontinue any product or service per JESD48, latest issue. Buyers should obtain the latest relevant information before placing orders and should verify that such information is current and complete.

TI's published terms of sale for semiconductor products (<http://www.ti.com/sc/docs/stdterms.htm>) apply to the sale of packaged integrated circuit products that TI has qualified and released to market. Additional terms may apply to the use or sale of other types of TI products and services.

Reproduction of significant portions of TI information in TI data sheets is permissible only if reproduction is without alteration and is accompanied by all associated warranties, conditions, limitations, and notices. TI is not responsible or liable for such reproduced documentation. Information of third parties may be subject to additional restrictions. Resale of TI products or services with statements different from or beyond the parameters stated by TI for that product or service voids all express and any implied warranties for the associated TI product or service and is an unfair and deceptive business practice. TI is not responsible or liable for any such statements.

Buyers and others who are developing systems that incorporate TI products (collectively, "Designers") understand and agree that Designers remain responsible for using their independent analysis, evaluation and judgment in designing their applications and that Designers have full and exclusive responsibility to assure the safety of Designers' applications and compliance of their applications (and of all TI products used in or for Designers' applications) with all applicable regulations, laws and other applicable requirements. Designer represents that, with respect to their applications, Designer has all the necessary expertise to create and implement safeguards that (1) anticipate dangerous consequences of failures, (2) monitor failures and their consequences, and (3) lessen the likelihood of failures that might cause harm and take appropriate actions. Designer agrees that prior to using or distributing any applications that include TI products, Designer will thoroughly test such applications and the functionality of such TI products as used in such applications.

TI's provision of technical, application or other design advice, quality characterization, reliability data or other services or information, including, but not limited to, reference designs and materials relating to evaluation modules, (collectively, "TI Resources") are intended to assist designers who are developing applications that incorporate TI products; by downloading, accessing or using TI Resources in any way, Designer (individually or, if Designer is acting on behalf of a company, Designer's company) agrees to use any particular TI Resource solely for this purpose and subject to the terms of this Notice.

TI's provision of TI Resources does not expand or otherwise alter TI's applicable published warranties or warranty disclaimers for TI products, and no additional obligations or liabilities arise from TI providing such TI Resources. TI reserves the right to make corrections, enhancements, improvements and other changes to its TI Resources. TI has not conducted any testing other than that specifically described in the published documentation for a particular TI Resource.

Designer is authorized to use, copy and modify any individual TI Resource only in connection with the development of applications that include the TI product(s) identified in such TI Resource. NO OTHER LICENSE, EXPRESS OR IMPLIED, BY ESTOPPEL OR OTHERWISE TO ANY OTHER TI INTELLECTUAL PROPERTY RIGHT, AND NO LICENSE TO ANY TECHNOLOGY OR INTELLECTUAL PROPERTY RIGHT OF TI OR ANY THIRD PARTY IS GRANTED HEREIN, including but not limited to any patent right, copyright, mask work right, or other intellectual property right relating to any combination, machine, or process in which TI products or services are used. Information regarding or referencing third-party products or services does not constitute a license to use such products or services, or a warranty or endorsement thereof. Use of TI Resources may require a license from a third party under the patents or other intellectual property of the third party, or a license from TI under the patents or other intellectual property of TI.

TI RESOURCES ARE PROVIDED "AS IS" AND WITH ALL FAULTS. TI DISCLAIMS ALL OTHER WARRANTIES OR REPRESENTATIONS, EXPRESS OR IMPLIED, REGARDING RESOURCES OR USE THEREOF, INCLUDING BUT NOT LIMITED TO ACCURACY OR COMPLETENESS, TITLE, ANY EPIDEMIC FAILURE WARRANTY AND ANY IMPLIED WARRANTIES OF MERCHANTABILITY, FITNESS FOR A PARTICULAR PURPOSE, AND NON-INFRINGEMENT OF ANY THIRD PARTY INTELLECTUAL PROPERTY RIGHTS. TI SHALL NOT BE LIABLE FOR AND SHALL NOT DEFEND OR INDEMNIFY DESIGNER AGAINST ANY CLAIM, INCLUDING BUT NOT LIMITED TO ANY INFRINGEMENT CLAIM THAT RELATES TO OR IS BASED ON ANY COMBINATION OF PRODUCTS EVEN IF DESCRIBED IN TI RESOURCES OR OTHERWISE. IN NO EVENT SHALL TI BE LIABLE FOR ANY ACTUAL, DIRECT, SPECIAL, COLLATERAL, INDIRECT, PUNITIVE, INCIDENTAL, CONSEQUENTIAL OR EXEMPLARY DAMAGES IN CONNECTION WITH OR ARISING OUT OF TI RESOURCES OR USE THEREOF, AND REGARDLESS OF WHETHER TI HAS BEEN ADVISED OF THE POSSIBILITY OF SUCH DAMAGES.

Unless TI has explicitly designated an individual product as meeting the requirements of a particular industry standard (e.g., ISO/TS 16949 and ISO 26262), TI is not responsible for any failure to meet such industry standard requirements.

Where TI specifically promotes products as facilitating functional safety or as compliant with industry functional safety standards, such products are intended to help enable customers to design and create their own applications that meet applicable functional safety standards and requirements. Using products in an application does not by itself establish any safety features in the application. Designers must ensure compliance with safety-related requirements and standards applicable to their applications. Designer may not use any TI products in life-critical medical equipment unless authorized officers of the parties have executed a special contract specifically governing such use. Life-critical medical equipment is medical equipment where failure of such equipment would cause serious bodily injury or death (e.g., life support, pacemakers, defibrillators, heart pumps, neurostimulators, and implantables). Such equipment includes, without limitation, all medical devices identified by the U.S. Food and Drug Administration as Class III devices and equivalent classifications outside the U.S.

TI may expressly designate certain products as completing a particular qualification (e.g., Q100, Military Grade, or Enhanced Product). Designers agree that it has the necessary expertise to select the product with the appropriate qualification designation for their applications and that proper product selection is at Designers' own risk. Designers are solely responsible for compliance with all legal and regulatory requirements in connection with such selection.

Designer will fully indemnify TI and its representatives against any damages, costs, losses, and/or liabilities arising out of Designer's non-compliance with the terms and provisions of this Notice.

## Looking for pricing, stock, or lifecycle information?

Click below to explore more details on WIN SOURCE:

 [View ADS1226IRGVT on WIN SOURCE](#)

 [Texas Instruments](#) Information

## Optimize Your Supply Chain with WIN SOURCE Solutions

-  Global Sourcing Solution
-  Obsolete Management
-  Cost Control Management
-  Shortage Management
-  Alternative Solution
-  Excess Inventory Management