



**THE DATASHEET OF
ADS5517IRGZT**



11-BIT, 200 MSPS ADC

FEATURES

- **Maximum Sample Rate: 200 MSPS**
- **11-Bit Resolution**
- **No Missing Codes**
- **Total Power Dissipation 1.23 W**
- **Internal Sample and Hold**
- **67-dBFS SNR at 70-MHz IF**
- **84-dBc SFDR at 70-MHz IF, 0-dB Gain**
- **High Analog Bandwidth up to 800 MHz**
- **Double Data Rate (DDR) LVDS and Parallel CMOS Output Options**
- **Programmable Gain up to 6 dB for SNR/SFDR Trade-Off at High IF**
- **Reduced Power Modes at Lower Sample Rates**
- **Supports Input Clock Amplitude Down to 400 mV_{PP}**

DESCRIPTION

ADS5517 is a high performance 11-bit, 200-MSPS A/D converter. It offers state-of-the art functionality and performance using advanced techniques to minimize board space. With high analog bandwidth and low jitter input clock buffer, the ADC supports both high SNR and high SFDR at high input frequencies. It features programmable gain options that can be used to improve SFDR performance at lower full-scale analog input ranges.

- **Clock Duty Cycle Stabilizer**
- **No External Reference Decoupling Required**
- **Internal and External Reference Support**
- **Programmable Output Clock Position to Ease Data Capture**
- **3.3-V Analog and Digital Supply**
- **48-QFN Package (7 mm × 7 mm)**

APPLICATIONS

- **Wireless Communications Infrastructure**
- **Software Defined Radio**
- **Power Amplifier Linearization**
- **802.16d/e**
- **Test and Measurement Instrumentation**
- **High Definition Video**
- **Medical Imaging**
- **Radar Systems**

In a compact 48-pin QFN, the device offers fully differential LVDS DDR (Double Data Rate) interface while parallel CMOS outputs can also be selected. Flexible output clock position programmability is available to ease capture and trade-off setup for hold times. At lower sampling rates, the ADC can be operated at scaled down power with no loss in performance. The ADS5517 includes an internal reference, while eliminating the traditional reference pins and associated external decoupling. The device also supports an external reference mode.

The device is specified over the industrial temperature range (-40°C to 85°C).

ADS5517 PRODUCT FAMILY

	210 MSPS	190 MSPS	170 MSPS
14 bit	ADS5547	ADS5546	ADS5545
12 bit	ADS5527	-	ADS5525
11 bit	ADS5517 (200MSPS)		



Please be aware that an important notice concerning availability, standard warranty, and use in critical applications of Texas Instruments semiconductor products and disclaimers thereto appears at the end of this data sheet.



This integrated circuit can be damaged by ESD. Texas Instruments recommends that all integrated circuits be handled with appropriate precautions. Failure to observe proper handling and installation procedures can cause damage.

ESD damage can range from subtle performance degradation to complete device failure. Precision integrated circuits may be more susceptible to damage because very small parametric changes could cause the device not to meet its published specifications.

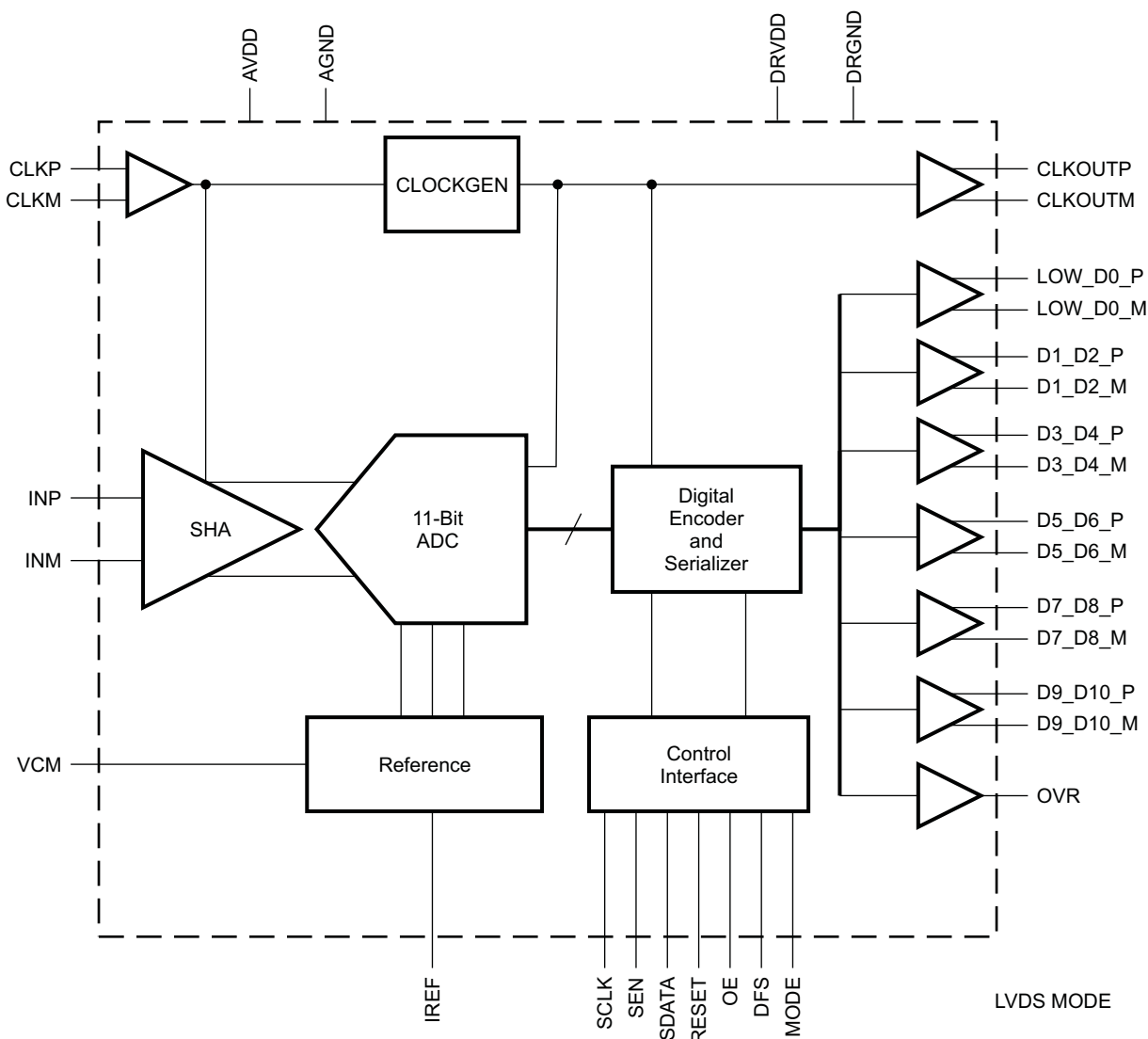

PACKAGE/ORDERING INFORMATION⁽¹⁾

PRODUCT	PACKAGE-LEAD	PACKAGE DESIGNATOR	SPECIFIED TEMPERATURE RANGE	PACKAGE MARKING	ORDERING NUMBER	TRANSPORT MEDIA, QUANTITY
ADS5517	QFN-48 ⁽²⁾	RGZ	-40°C to 85°C	AZ5517	ADS5517IRGZT	Tape and Reel, 250
					ADS5517IRGZR	Tape and Reel, 2500

(1) For the most current package and ordering information, see the Package Option Addendum at the end of this document, or see the TI website at www.ti.com.
 (2) For thermal pad size on the package, see the mechanical drawings at the end of this data sheet. $\theta_{JA} = 25.41^{\circ}\text{C/W}$ (0 LFM air flow), $\theta_{JC} = 16.5^{\circ}\text{C/W}$ when used with 2 oz. copper trace and pad soldered directly to a JEDEC standard four layer 3 in x 3 in (7.62 cm x 7.62 cm) PCB.

ABSOLUTE MAXIMUM RATINGS⁽¹⁾

over operating free-air temperature range (unless otherwise noted)

		VALUE	UNIT
	Supply voltage range, AVDD	-0.3 to 3.9	V
	Supply voltage range, DRVDD	-0.3 to 3.9	V
	Voltage between AGND and DRGND	-0.3 to 0.3	V
	Voltage between AVDD to DRVDD	-0.3 to 3.3	V
	Voltage applied to VCM pin (in external reference mode)	-0.3 to 1.8	V
	Voltage applied to analog input pins, INP and INM	-0.3 to minimum (3.6, AVDD + 0.3)	V
	Voltage applied to input clock pins, CLKP and CLKM	-0.3 to AVDD + 0.3	V
T _A	Operating free-air temperature range	-40 to 85	°C
T _J	Operating junction temperature range	125	°C
T _{stg}	Storage temperature range	-65 to 150	°C

(1) Stresses beyond those listed under *absolute maximum ratings* may cause permanent damage to the device. These are stress ratings only and functional operation of the device at these or any other conditions beyond those indicated under *recommended operating conditions* is not implied. Exposure to absolute maximum rated conditions for extended periods may affect device reliability.

RECOMMENDED OPERATING CONDITIONS

over operating free-air temperature range (unless otherwise noted)

	MIN	TYP	MAX	UNIT	
SUPPLIES					
	Analog supply voltage, AVDD	3	3.3	3.6	V
	Digital supply voltage, DRVDD	3	3.3	3.6	V
ANALOG INPUTS					
	Differential input voltage range	2		V _{PP}	
	Input common-mode voltage	1.5 ±0.1		V	
	Voltage applied on VCM in external reference mode	1.45	1.5	1.55	V
CLOCK INPUT					
	Input clock sample rate ⁽¹⁾			MSPS	
	DEFAULT SPEED mode	50		200	MSPS
	LOW SPEED mode	1		60	
	Input clock amplitude differential (V _(CLKP) - V _(CLKM))				
	Sine wave, ac-coupled	0.4	1.5		V _{PP}
	LVPECL, ac-coupled			1.6	V _{PP}
	LVDS, ac-coupled			0.7	V _{PP}
	LVCMOS, single-ended, ac-coupled			3.3	V
	Input clock duty cycle (See Figure 25)	35%	50%	65%	
DIGITAL OUTPUTS					
C _L	Maximum external load capacitance from each output pin to DRGND (LVDS and CMOS modes)				
	Without internal termination (default after reset)			5	pF
	With 100 Ω internal termination ⁽²⁾			10	pF
R _L	Differential load resistance between the LVDS output pairs (LVDS mode)			100	Ω
	Operating free-air temperature	-40		85	°C

(1) See the section on *Low Sampling Frequency Operation* for more information.

(2) See the section on *LVDS Buffer Internal termination* for more information.

ELECTRICAL CHARACTERISTICS

Typical values are at 25°C, min and max values are across the full temperature range $T_{MIN} = -40^{\circ}C$ to $T_{MAX} = 85^{\circ}C$, $AVDD = DRVDD = 3.3 V$, sampling rate = 200 MSPS, sine wave input clock, 1.5 V_{PP} differential clock amplitude, 50% clock duty cycle, -1 dBFS differential analog input, internal reference mode, 0-db gain, DDR LVDS data output (unless otherwise noted)

PARAMETER		TEST CONDITIONS	MIN	TYP	MAX	UNIT
Resolution				11		bits
ANALOG INPUT						
Differential input voltage range				2		V_{PP}
Differential input capacitance				7		pF
Analog input bandwidth				800		MHz
Analog input common mode current (per input pin)				342		μA
REFERENCE VOLTAGES						
$V_{(REFB)}$	Internal reference bottom voltage	Internal reference mode		0.5		V
$V_{(REFT)}$	Internal reference top voltage	Internal reference mode		2.5		V
$\Delta V_{(REF)}$	Internal reference error	$V_{(REFT)} - V_{(REFB)}$	-60	± 25	60	mV
V_{CM}	Common mode output voltage	Internal reference mode		1.5		V
VCM output current capability		Internal reference mode		± 4		mA
DC ACCURACY						
No Missing Codes				Specified		
DNL	Differential non-linearity		-0.6	± 0.3	1.0	LSB
INL	Integral non-linearity		-1.5	± 0.6	1.5	LSB
Offset error			-10	5	10	mV
Offset temperature coefficient				0.002		ppm/ $^{\circ}C$
Gain error due to internal reference error alone		$(\Delta V_{(REF)} / 2.0V)\%$	-3	± 1	3	%FS
Gain error excluding internal reference error ⁽¹⁾			-2	± 1	2	%FS
Gain temperature coefficient				0.01		$\Delta\%/^{\circ}C$
PSRR	DC Power supply rejection ratio			0.6		mV/V
POWER SUPPLY						
$I_{(AVDD)}$	Analog supply current			306		mA
$I_{(DRVDD)}$	Digital supply current	LVDS mode, $I_O = 3.5 mA$, $R_L = 100 \Omega$, $C_L = 5 pF$		66		mA
		CMOS mode, $F_{IN} = 2.5 MHz$, $C_L = 5 pF$		47		mA
I_{CC}	Total supply current	LVDS mode		372		mA
Total power dissipation		LVDS mode		1.23	1.4	W
Standby power		In STANDBY mode with clock stopped		100	150	mW
Clock stop power		With input clock stopped		100	150	mW

(1) Gain error is specified from design and characterization; it is not tested in production.

ELECTRICAL CHARACTERISTICS

Typical values are at 25°C, min and max values are across the full temperature range $T_{MIN} = -40^{\circ}\text{C}$ to $T_{MAX} = 85^{\circ}\text{C}$, $AVDD = DRVDD = 3.3\text{ V}$, sampling rate = 200 MSPS, sine wave input clock, 1.5 V_{PP} differential clock amplitude, 50% clock duty cycle, -1 dBFS differential analog input, internal reference mode, 0-dB gain, DDR LVDS data output (unless otherwise noted)

PARAMETER		TEST CONDITIONS		MIN	TYP	MAX	UNIT			
AC CHARACTERISTICS										
SNR	Signal to noise ratio	$F_{IN} = 20\text{ MHz}$				67.1	dBFS			
		$F_{IN} = 70\text{ MHz}$		64.5	66.9					
		$F_{IN} = 100\text{ MHz}$				66.8				
		$F_{IN} = 170\text{ MHz}$				66.6				
		$F_{IN} = 230\text{ MHz}$	0 dB gain, 2 V_{PP} FS ⁽¹⁾					66		
			3 dB gain, 1.4 V_{PP} FS					65.4		
		$F_{IN} = 400\text{ MHz}$	0 dB gain, 2 V_{PP} FS					65		
			3 dB gain, 1.4 V_{PP} FS					64.5		
SFDR	Spurious free dynamic range	$F_{IN} = 20\text{ MHz}$				86	dBc			
		$F_{IN} = 70\text{ MHz}$		75	84					
		$F_{IN} = 100\text{ MHz}$				78				
		$F_{IN} = 170\text{ MHz}$				79				
		$F_{IN} = 230\text{ MHz}$	0 dB gain, 2 V_{PP} FS					75		
			3 dB gain, 1.4 V_{PP} FS					78		
		$F_{IN} = 300\text{ MHz}$	0 dB gain, 2 V_{PP} FS					74		
			3 dB gain, 1.4 V_{PP} FS					76		
		$F_{IN} = 400\text{ MHz}$	0 dB gain, 2 V_{PP} FS					68		
			3 dB gain, 1.4 V_{PP} FS					70		
		SINAD	Signal to noise and distortion ratio	$F_{IN} = 20\text{ MHz}$				67	dBFS	
				$F_{IN} = 70\text{ MHz}$		64		66.8		
$F_{IN} = 100\text{ MHz}$						66.6				
$F_{IN} = 170\text{ MHz}$						66.4				
$F_{IN} = 230\text{ MHz}$	0 dB gain, 2 V_{PP} FS					65				
	3 dB gain, 1.4 V_{PP} FS					65				
$F_{IN} = 400\text{ MHz}$	0 dB gain, 2 V_{PP} FS					62.8				
	3 dB gain, 1.4 V_{PP} FS					62.9				
HD2	Second harmonic	$F_{IN} = 20\text{ MHz}$				91	dBc			
		$F_{IN} = 70\text{ MHz}$		75	88					
		$F_{IN} = 100\text{ MHz}$				87				
		$F_{IN} = 170\text{ MHz}$				87				
		$F_{IN} = 230\text{ MHz}$	0 dB gain, 2 V_{PP} FS					86		
			3 dB gain, 1.4 V_{PP} FS					88		
		$F_{IN} = 300\text{ MHz}$	0 dB gain, 2 V_{PP} FS					78		
			3 dB gain, 1.4 V_{PP} FS					80		
		$F_{IN} = 400\text{ MHz}$	0 dB gain, 2 V_{PP} FS					69		
			3 dB gain, 1.4 V_{PP} FS					71		

(1) FS = Full scale range

ELECTRICAL CHARACTERISTICS (continued)

Typical values are at 25°C, min and max values are across the full temperature range $T_{MIN} = -40^{\circ}C$ to $T_{MAX} = 85^{\circ}C$, $AVDD = DRVDD = 3.3 V$, sampling rate = 200 MSPS, sine wave input clock, 1.5 V_{PP} differential clock amplitude, 50% clock duty cycle, -1 dBFS differential analog input, internal reference mode, 0-dB gain, DDR LVDS data output (unless otherwise noted)

PARAMETER		TEST CONDITIONS	MIN	TYP	MAX	UNIT	
HD3	Third harmonic	$F_{IN} = 20 \text{ MHz}$		86		dBc	
		$F_{IN} = 70 \text{ MHz}$	75	84			
		$F_{IN} = 100 \text{ MHz}$		78			
		$F_{IN} = 170 \text{ MHz}$		79			
		$F_{IN} = 230 \text{ MHz}$	0 dB gain, 2 V_{PP} FS		75		
			3 dB gain, 1.4 V_{PP} FS		78		
		$F_{IN} = 300 \text{ MHz}$	0 dB gain, 2 V_{PP} FS		74		
			3 dB gain, 1.4 V_{PP} FS		76		
		$F_{IN} = 400 \text{ MHz}$	0 dB gain, 2 V_{PP} FS		68		
			3 dB gain, 1.4 V_{PP} FS		70		
Worst harmonic (other than HD2, HD3)		$F_{IN} = 20 \text{ MHz}$		95		dBc	
		$F_{IN} = 70 \text{ MHz}$		92			
		$F_{IN} = 100 \text{ MHz}$		92			
		$F_{IN} = 170 \text{ MHz}$		90			
		$F_{IN} = 230 \text{ MHz}$		90			
		$F_{IN} = 300 \text{ MHz}$		88			
		$F_{IN} = 400 \text{ MHz}$		87			
THD	Total harmonic distortion	$F_{IN} = 20 \text{ MHz}$		83		dBc	
		$F_{IN} = 70 \text{ MHz}$	73	82			
		$F_{IN} = 100 \text{ MHz}$		76			
		$F_{IN} = 170 \text{ MHz}$		77			
		$F_{IN} = 230 \text{ MHz}$		73			
		$F_{IN} = 300 \text{ MHz}$		72			
		$F_{IN} = 400 \text{ MHz}$		65			
ENOB	Effective number of bits	$F_{IN} = 70 \text{ MHz}$	10.3	10.8		bits	
IMD	Two-tone intermodulation distortion	$F_{IN1} = 50.03 \text{ MHz}, F_{IN2} = 46.03 \text{ MHz},$ -7 dBFS each tone		91		dBFS	
		$F_{IN1} = 190.1 \text{ MHz}, F_{IN2} = 185.02 \text{ MHz},$ -7 dBFS each tone		86			
PSRR	AC power supply rejection ratio	30 MHz, 200 mV _{PP} signal on 3.3-V supply		35		dBc	
	Voltage overload recovery time	Recovery to 1% (of final value) for 6-dB overload with sine-wave input at Nyquist frequency		1		Clock cycles	

DIGITAL CHARACTERISTICS⁽¹⁾

The DC specifications refer to the condition where the digital outputs are not switching, but are permanently at a valid logic level 0 or 1 AVDD = DRVDD = 3.3 V, I_O = 3.5 mA, R_L = 100 Ω⁽²⁾

PARAMETER	TEST CONDITIONS	MIN	TYP	MAX	UNIT
DIGITAL INPUTS					
High-level input voltage		2.4			V
Low-level input voltage				0.8	V
High-level input current			33		μA
Low-level input current			–33		μA
Input capacitance			4		pF
DIGITAL OUTPUTS – CMOS MODE					
High-level output voltage			3.3		V
Low-level output voltage			0		V
Output capacitance	Output capacitance inside the device, from each output to ground		2		pF
DIGITAL OUTPUTS – LVDS MODE					
High-level output voltage			1375		mV
Low-level output voltage			1025		mV
Output differential voltage, V _{OD}		225	350	425	mV
V _{OS} Output offset voltage, single-ended	Common-mode voltage of OOTP and OUTM		1200		mV
Output capacitance	Output capacitance inside the device, from either output to ground		2		pF

(1) All LVDS and CMOS specifications are characterized, but not tested at production.

(2) I_O refers to the LVDS buffer current setting, R_L is the differential load resistance between the LVDS output pair.

TIMING CHARACTERISTICS – LVDS AND CMOS MODES⁽¹⁾

Typical values are at 25°C, min and max values are across the full temperature range T_{MIN} = –40°C to T_{MAX} = 85°C, AVDD = DRVDD = 3.3 V, sampling frequency = 200 MSPS, sine wave input clock, 1.5 V_{PP} clock amplitude, C_L = 5 pF⁽²⁾, I_O = 3.5 mA, R_L = 100 Ω⁽³⁾, no internal termination, unless otherwise noted.

For timings at lower sampling frequencies, see the *Output Timing* section in the APPLICATION INFORMATION of this data sheet.

PARAMETER	TEST CONDITIONS	MIN	TYP	MAX	UNIT
t _a Aperture delay			1.2		ns
t _j Aperture jitter			150		fs rms
Wake-up time	Time to valid data after coming out of STANDBY mode			100	μs
	Time to valid data after stopping and restarting the input clock			100	
Latency			14		clock cycles
DDR LVDS MODE⁽⁴⁾					
t _{SU} Data setup time ⁽⁵⁾	Data valid ⁽⁶⁾ to zero-cross of CLKOUTP	1.0	1.5		ns
t _H Data hold time ⁽⁵⁾	Zero-cross of CLKOUTP to data becoming invalid ⁽⁶⁾	0.35	0.8		ns

(1) Timing parameters are specified by design and characterization and not tested in production.

(2) C_L is the effective external single-ended load capacitance between each output pin and ground.

(3) I_O refers to the LVDS buffer current setting; R_L is the differential load resistance between the LVDS output pair.

(4) Measurements are done with a transmission line of 100 Ω characteristic impedance between the device and the load.

(5) Setup and hold time specifications take into account the effect of jitter on the output data and clock. These specifications also assume that the data and clock paths are perfectly matched within the receiver. Any mismatch in these paths within the receiver would appear as reduced timing margin.

(6) Data valid refers to logic high of +50 mV and logic low of –50 mV.

TIMING CHARACTERISTICS – LVDS AND CMOS MODES (continued)

For timings at lower sampling frequencies, see the *Output Timing* section in the APPLICATION INFORMATION of this data sheet.

PARAMETER		TEST CONDITIONS	MIN	TYP	MAX	UNIT
t_{PDI}	Clock propagation delay ⁽⁷⁾	Input clock rising edge zero-cross to output clock rising edge zero-cross	3.7	4.4	5.1	ns
	LVDS bit clock duty cycle	Duty cycle of differential clock, (CLKOUTP-CLKOUTM) $80 \leq F_s \leq 200$ MSPS	45%	50%	55%	
t_r , t_f	Data rise time, Data fall time	Rise time measured from –50 mV to 50 mV Fall time measured from 50 mV to –50 mV $1 \leq F_s \leq 200$ MSPS	50	100	200	ps
$t_{CLKRISE}$, $t_{CLKFALL}$	Output clock rise time, Output clock fall time	Rise time measured from –50 mV to 50 mV Fall time measured from 50 mV to –50 mV $1 \leq F_s \leq 200$ MSPS	50	100	200	ps
	Output clock jitter	Cycle-to-cycle jitter		120		ps pp
t_{OE}	Output enable (OE) to valid data delay	Time to valid data after OE becomes active			1	μ s
PARALLEL CMOS MODE						
t_{SU}	Data setup time ⁽⁵⁾	Data valid ⁽⁸⁾ to 50% of CLKOUT rising edge	1.8	2.6		ns
t_H	Data hold time ⁽⁵⁾	50% of CLKOUT rising edge to data becoming invalid ⁽⁸⁾	0.4	0.8		ns
t_{PDI}	Clock propagation delay ⁽⁷⁾	Input clock rising edge zero-cross to 50% of CLKOUT rising edge	2.6	3.4	4.2	ns
	Output clock duty cycle	Duty cycle of output clock (CLKOUT) $80 \leq F_s \leq 200$ MSPS		45%		
t_r , t_f	Data rise time, Data fall time	Rise time measured from 20% to 80% of DRVDD Fall time measured from 80% to 20% of DRVDD $1 \leq F_s \leq 200$ MSPS	0.8	1.5	2.0	ns
$t_{CLKRISE}$, $t_{CLKFALL}$	Output clock rise time, Output clock fall time	Rise time measured from 20% to 80% of DRVDD Fall time measured from 80% to 20% of DRVDD $1 \leq F_s \leq 200$ MSPS	0.4	0.8	1.2	ns
t_{OE}	Output enable (OE) to valid data delay	Time to valid data after OE becomes active			50	ns

(7) To use the input clock as the data capture clock, it is necessary to delay the input clock by a delay (t_D) to get the desired setup and hold times. Use either of these equations to calculate t_D :

Desired setup time = $t_D - (t_{PDI} - t_{SU})$

Desired hold time = $(t_{PDI} + t_H) - t_D$

(8) Data valid refers to logic high of 2 V and logic low of 0.8 V

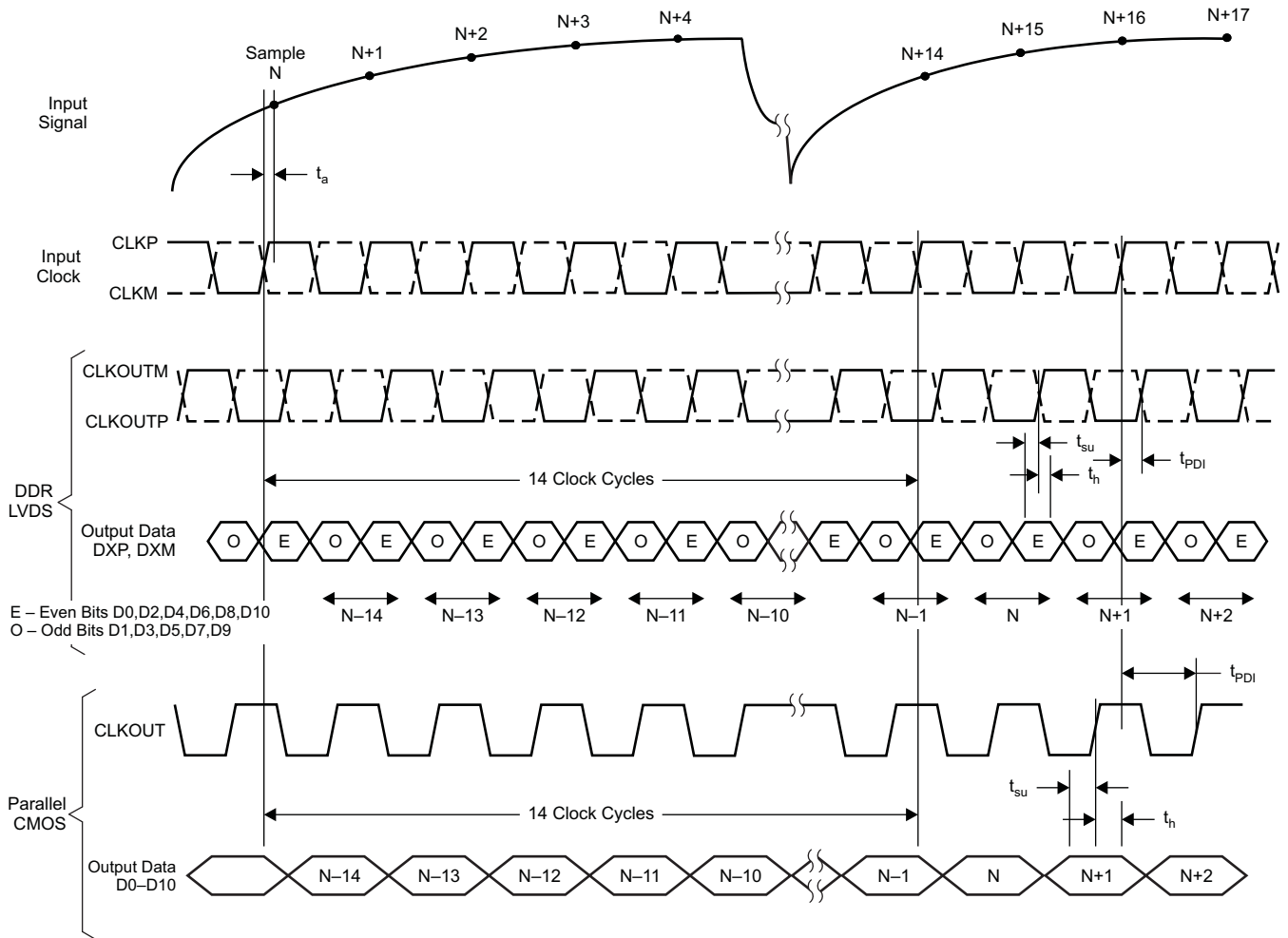
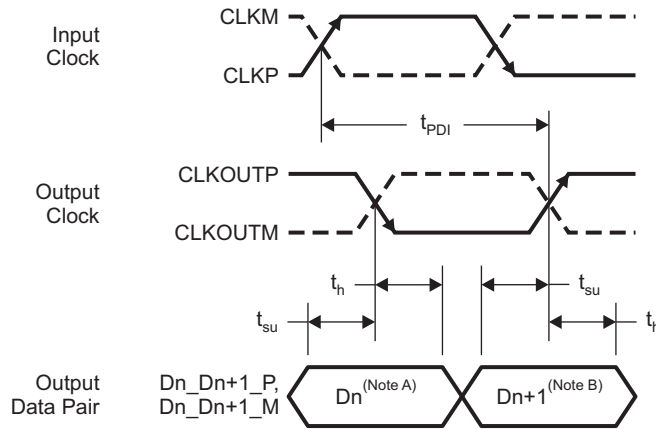
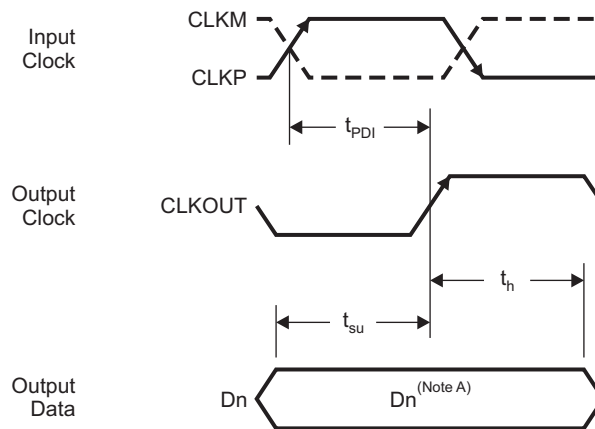

Figure 1. Latency



- A. Dn – Bits D1, D3, D5, D7, and D9
- B. Dn+1 – Bits D0, D2, D4, D6, D8, and D10

Figure 2. LVDS Mode Timing



- A. Dn – Bits D0–D10

Figure 3. CMOS Mode Timing

DEVICE PROGRAMMING MODES

ADS5517 offers flexibility with several programmable features that are easily configured.

The device can be configured independently using either parallel interface control or serial interface programming.

In addition, the device supports a third configuration mode, where both the parallel interface and the serial control registers are used. In this mode, the priority between the parallel and serial interfaces is determined by a priority table (Table 2). If this additional level of flexibility is not required, the user can select either the serial interface programming or the parallel interface control.

USING PARALLEL INTERFACE CONTROL ONLY

To control the device using parallel interface, keep RESET tied to **high** (DRVDD). Pins DFS, MODE, SEN, SCLK, and SDATA are used to directly control certain modes of the ADC. The device is configured by connecting the parallel pins to the correct voltage levels (as described in Table 3 to Table 7). There is no need to apply reset.

In this mode, SEN, SCLK, and SDATA function as parallel interface control pins. Frequently used functions are controlled in this mode—standby, selection between LVDS/CMOS output format, internal/external reference, two's complement/straight binary output format, and position of the output clock edge.

Table 1 has a description of the modes controlled by the parallel pins.

Table 1. Parallel Pin Definition

PIN	CONTROL MODES
DFS	DATA FORMAT and the LVDS/CMOS output interface
MODE	Internal or external reference
SEN	CLKOUT edge programmability
SCLK	LOW SPEED mode control for low sampling frequencies (< 50 MSPS)
SDATA	STANDBY mode – Global (ADC, internal references and output buffers are powered down)

USING SERIAL INTERFACE PROGRAMMING ONLY

To program using the serial interface, the internal registers must first be reset to their default values, and the RESET pin must be kept **low**. In this mode, SEN, SDATA, and SCLK function as serial interface pins and are used to access the internal registers of ADC. The registers are reset either by applying a pulse on the RESET pin, or by a **high** setting on the <RST> bit (D1 in register 0x6C). The *serial interface section* describes the register programming and register reset in more detail.

Since the parallel pins DFS and MODE are not used in this mode, they must be tied to ground.

USING BOTH THE SERIAL INTERFACE AND PARALLEL CONTROLS

For increased flexibility, a combination of serial interface registers and parallel pin controls (DFS, MODE) can also be used to configure the device.

The serial registers must first be reset to their default values and the RESET pin must be kept **low**. In this mode, SEN, SDATA, and SCLK function as serial interface pins and are used to access the internal registers of ADC. The registers are reset either by applying a pulse on RESET pin or by a **high** setting on the <RST> bit (D1 in register 0x6C). The *serial interface section* describes the register programming and register reset in more detail.

The parallel interface control pins DFS and MODE are used and their function is determined by the appropriate voltage levels as described in Table 6 and Table 7. The voltage levels are derived by using a resistor string as illustrated in Figure 4. Since some functions are controlled using both the parallel pins and serial registers, the priority between the two is determined by a priority table (Table 2).

Table 2. Priority Between Parallel Pins and Serial Registers

PIN	FUNCTIONS SUPPORTED	PRIORITY
MODE	Internal/External reference	When using the serial interface, bit <REF> (register 0x6D, bit D4) controls this mode, ONLY if the MODE pin is tied low.
DFS	DATA FORMAT	When using the serial interface, bit <DF> (register 0x63, bit D3) controls this mode, ONLY if the DFS pin is tied low.
	LVDS/CMOS	When using the serial interface, bit <ODI> (register 0x6C, bits D3-D4) controls LVDS/CMOS selection independent of the state of DFS pin

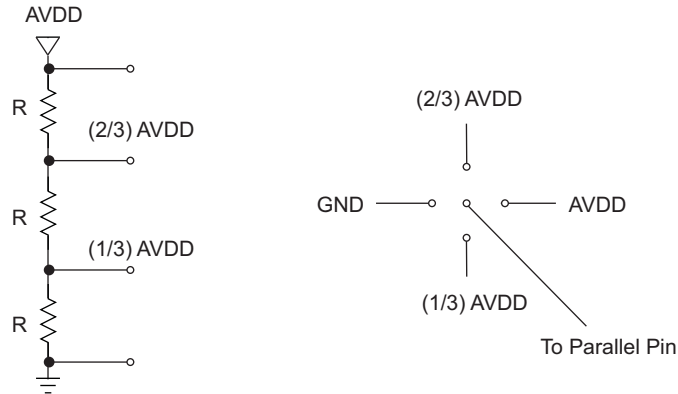

Figure 4. Simple Scheme to Configure Parallel Pins

DESCRIPTION OF PARALLEL PINS
Table 3. SCLK Control Pin

SCLK (Pin 29)	DESCRIPTION
0	LOW SPEED mode Disabled - Use for sampling frequencies above 50 MSPS.
DRVDD	LOW SPEED mode Enabled - Use for sampling frequencies below 50 MSPS.

Table 4. SDATA Control Pin

SDATA (Pin 28)	DESCRIPTION
0	Normal operation (Default)
DRVDD	STANDBY. This is a global power down, where ADC, internal references and the output buffers are powered down.

Table 5. SEN Control Pin

SEN (Pin 27)	DESCRIPTION
0	CMOS mode: CLKOUT edge later by $(3/12)T_s$ ⁽¹⁾ ; LVDS mode: CLKOUT edge aligned with data transition
(1/3)DRVDD	CMOS mode: CLKOUT edge later by $(2/12)T_s$; LVDS mode: CLKOUT edge aligned with data transition
(2/3)DRVDD	CMOS mode: CLKOUT edge later by $(1/12)T_s$; LVDS mode: CLKOUT edge earlier by $(1/12)T_s$
DRVDD	Default CLKOUT position

(1) $T_s = 1/\text{Sampling Frequency}$

Table 6. DFS Control Pin

DFS (Pin 6)	DESCRIPTION
0	2's complement data and DDR LVDS output (Default)
(1/3)DRVDD	2's complement data and parallel CMOS output
(2/3)DRVDD	Offset binary data and parallel CMOS output
DRVDD	Offset binary data and DDR LVDS output

Table 7. MODE Control Pin

MODE (Pin 23)	DESCRIPTION
0	Internal reference
(1/3)AVDD	External reference
(2/3)AVDD	External reference
AVDD	Internal reference

SERIAL INTERFACE

The ADC has a set of internal registers, which can be accessed through the serial interface formed by pins SEN (Serial interface Enable), SCLK (Serial Interface Clock), SDATA (Serial Interface Data) and RESET. After device power-up, the internal registers must be reset to their default values by applying a high-going pulse on RESET (of width greater than 10 ns).

Serial shift of bits into the device is enabled when SEN is low. Serial data SDATA is latched at every falling edge of SCLK when SEN is active (low). The serial data is loaded into the register at every 16th SCLK falling edge when SEN is low. If the word length exceeds a multiple of 16 bits, the excess bits are ignored. Data is loaded in multiples of 16-bit words within a single active SEN pulse.

The first 8 bits form the register address and the remaining 8 bits form the register data. The interface can work with SCLK frequency from 20 MHz down to very low speeds (few Hertz) and also with non-50% SCLK duty cycle.

REGISTER INITIALIZATION

After power-up, the internal registers *must* be reset to their default values. This is done in one of two ways:

1. Either through hardware reset by applying a high-going pulse on RESET pin (of width greater than 10 ns) as shown in Figure 5.

OR

2. By applying software reset. Using the serial interface, set the <RST> bit (D1 in register 0x6C) to **high**. This initializes the internal registers to their default values and then self-resets the <RST> bit to **low**. In this case the RESET pin is kept **low**.

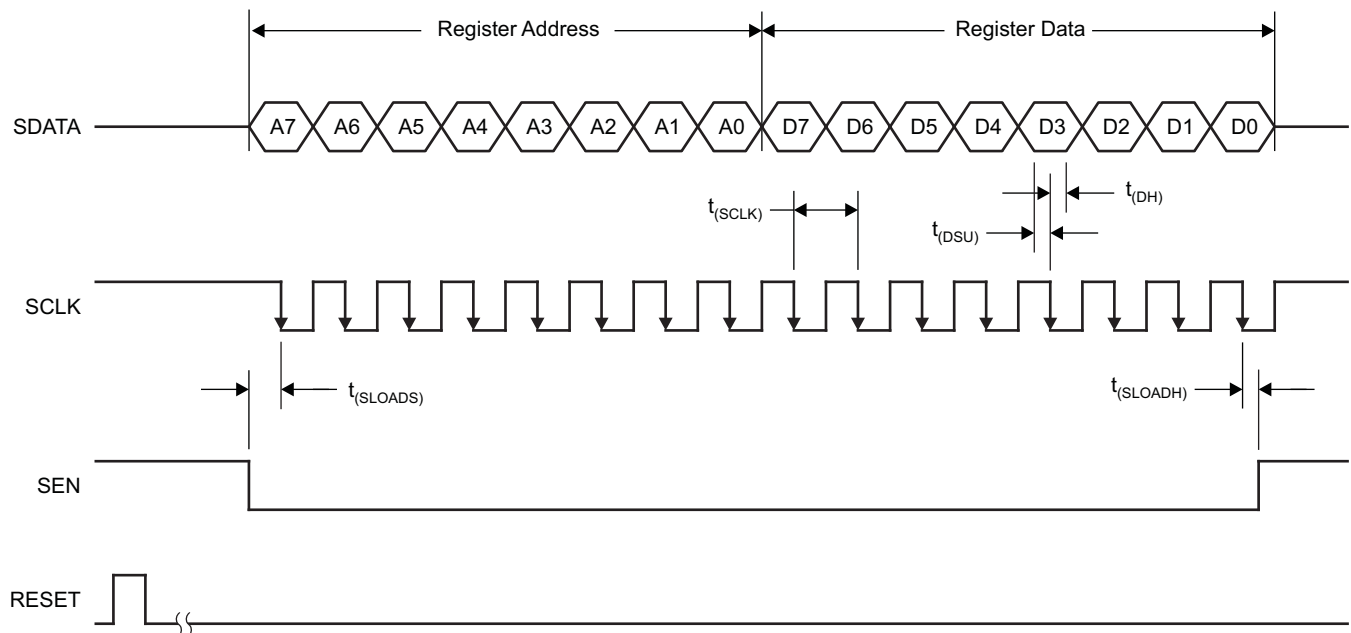

Figure 5. Serial Interface Timing Diagram

SERIAL INTERFACE TIMING CHARACTERISTICS

Typical values at 25°C, min and max values across the full temperature range $T_{MIN} = -40^{\circ}C$ to $T_{MAX} = 85^{\circ}C$, $AVDD = DRVDD = 3.3 V$ (unless otherwise noted)

		MIN	TYP	MAX	UNIT
f_{SCLK}	SCLK frequency	> DC		20	MHz
t_{SLOADS}	SEN to SCLK setup time		25		ns
t_{SLOADH}	SCLK to SEN hold time		25		ns
t_{DSU}	SDATA setup time		25		ns
t_{DH}	SDATA hold time		25		ns

RESET TIMING

Typical values at 25°C, min and max values across the full temperature range $T_{MIN} = -40^{\circ}C$ to $T_{MAX} = 85^{\circ}C$, $AVDD = DRVDD = 3.3\text{ V}$ (unless otherwise noted)

PARAMETER	TEST CONDITIONS	MIN	TYP	MAX	UNIT
t_1	Power-on delay	Delay from power-up of AVDD and DRVDD to RESET pulse active		5	ms
t_2	Reset pulse width	Pulse width of active RESET signal		10	ns
t_3	Register write delay	Delay from RESET disable to SEN active		25	ns
t_{PO}	Power-up time	Delay from power-up of AVDD and DRVDD to output stable		6.5	ms

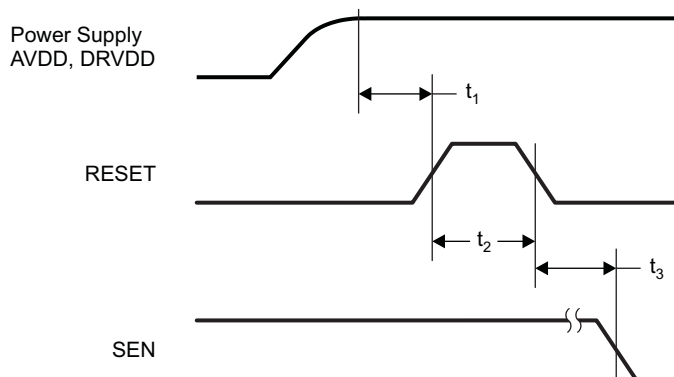

NOTE: A high-going pulse on RESET pin is required in serial interface mode in case of initialization through hardware reset. For parallel interface operation, RESET has to be tied permanently HIGH.

Figure 6. Reset Timing Diagram

SERIAL REGISTER MAP

Table 8 gives a summary of all the modes that can be programmed through the serial interface.

Table 8. Summary of Functions Supported by Serial Interface ⁽¹⁾⁽²⁾

REGISTER ADDRESS IN HEX	REGISTER FUNCTIONS								
	A7 – A0	D7	D6	D5	D4	D3	D2	D1	D0
62		<DATA POSN> OUTPUT DATA POSITION PROGRAMMABILITY			<CLKOUT POSN> OUTPUT CLOCK POSITION PROGRAMMABILITY				
63	<STBY> GLOBAL POWER DOWN				<LOW SPEED> ENABLE LOW SAMPLING FREQUENCY OPERATION	<DF> DATA FORMAT - 2's COMP or STRAIGHT BINARY			
65	<TEST PATTERN> – ALL 0s, ALL 1s, TOGGLE, RAMP, CUSTOM PATTERN								
68					<GAIN> GAIN PROGRAMMING <GAIN> - 1 dB to 6 dB				
69	<CUSTOM A> CUSTOM PATTERN (D7 TO D0)								
6A			<CUSTOM B> CUSTOM PATTERN (D13 TO D8)						
6B			<CLKIN GAIN> INPUT CLOCK BUFFER GAIN PROGRAMMABILITY						
6C					<ODI> OUTPUT DATA INTERFACE - DDR LVDS or PARALLEL CMOS			<RST> SOFTWARE RESET	
6D	<SCALING> POWER SCALING				<REF> INTERNAL or EXTERNAL REFERENCE				
7E	<DATA TERM> INTERNAL TERMINATION – DATA OUTPUTS				<CLKOUT TERM> INTERNAL TERMINATION – OUTPUT CLOCK			<LVDS CURR> LVDS CURRENT PROGRAMMABILITY	
7F	<CURR DOUBLE> LVDS CURRENT DOUBLE								

(1) The unused bits in each register (shown by blank cells in above table) must be programmed as '0'.
 (2) Multiple functions in a register can be programmed in a single write operation.

DESCRIPTION OF SERIAL REGISTERS

Each register function is explained in detail below.

Table 9. Serial Register A

A7 – A0 (hex)	D7	D6	D5	D4	D3	D2	D1	D0
62		<DATA POSN> OUTPUT DATA POSITION PROGRAMMABILITY		<CLKOUT POSN> OUTPUT CLOCK POSITION PROGRAMMABILITY				

D4 — D0

<CLKOUT POSN> Output clock position programmability

00001	Default CLKOUT position after reset. Setup/hold timings with this clock position are specified in the timing characteristics table.
XX011	CMOS – Falling edge later by (1/12) Ts LVDS – Falling edge earlier by (1/12) Ts
XX101	CMOS – Falling edge later by (3/12) Ts LVDS – Falling edge aligned with data transition
XX111	CMOS – Falling edge later by (2/12) Ts LVDS – Falling edge aligned with data transition
01XX1	CMOS – Rising edge later by (1/12) Ts LVDS – Rising edge earlier by (1/12) Ts
10XX1	CMOS – Rising edge later by (3/12) Ts LVDS – Rising edge aligned with data transition
11XX1	CMOS – Rising edge later by (2/12) Ts LVDS – Rising edge aligned with data transition

D6 — D5

<DATA POSN> Output Switching Noise and Data Position Programmability (in CMOS mode ONLY) (Only in CMOS mode)

00	Data Position 1 – Default output data position after reset. Setup/hold timings with this data position are specified in the timing characteristics table.
01	Data Position 2 – Setup time increases by (2/36) Ts
10	Data Position 3 – Setup time increases by (5/36) Ts
11	Data Position 4 – Setup time decreases by (6/36) Ts

Table 10. Serial Register B

A7 – A0 (hex)	D7	D6	D5	D4	D3	D2	D1	D0
63	<STBY> GLOBAL POWER DOWN			<LOW SPEED> ENABLE LOW SAMPLING FREQUENCY OPERATION	<DF> DATA FORMAT 2's COMP or STRAIGHT BINARY			

- D3** **<DF> Output data format**
-
- 0 2's complement
- 1 Straight binary
- D4** **<LOW SPEED> Low sampling frequency operation**
-
- 0 Default SPEED mode for $50 < F_s \leq 200$ MSPS
- 1 Low SPEED mode $1 \leq F_s \leq 50$ MSPS
- D7** **<STBY> Global power down**
-
- 0 Normal operation
- 1 Global power down (includes ADC, internal references and output buffers)

Table 11. Serial Register C

A7 – A0 (hex)	D7	D6	D5	D4	D3	D2	D1	D0
65	<TEST PATTERNS> — ALL 0s, ALL 1s, TOGGLE, RAMP, CUSTOM PATTERN							

- D7 — D5** **<TEST PATTERN> Outputs selected test pattern on data lines**
-
- 000 Normal operation
- 001 All 0s
- 010 All 1s
- 011 Toggle pattern – alternate 1s and 0s on each data output and across data outputs
- 100 Ramp pattern – Output data ramps from 0x0000 to 0x3FFF by one code every clock cycle
- 101 Custom pattern – Outputs the custom pattern in CUSTOM PATTERN registers A and B
- 111 Unused

Table 12. Serial Register D

A7 – A0 (hex)	D7	D6	D5	D4	D3	D2	D1	D0
68					<GAIN> GAIN PROGRAMMING <GAIN> - 1 dB to 6 dB			

D3 — D0 **<GAIN> Gain programmability**

1000	0 dB gain, default after reset
1001	1 dB
1010	2 dB
1011	3 dB
1100	4 dB
1101	5 dB
1110	6 dB

Table 13. Serial Register E

A7 – A0 (hex)	D7	D6	D5	D4	D3	D2	D1	D0
69	<CUSTOM A> CUSTOM PATTERN (D4 TO D0)							
6A			<CUSTOM B> CUSTOM PATTERN (D10 TO D5)					

Reg 69 D7 — D3 Program bits D4 to D0 of custom pattern

Reg 6A D5 — D0 Program bits D10 to D5 of custom pattern

Table 14. Serial Register F

A7 – A0 (hex)	D7	D6	D5	D4	D3	D2	D1	D0
6B	<CLKIN GAIN> INPUT CLOCK BUFFER GAIN PROGRAMMABILITY							

D5 - D0 **<CLKIN GAIN> Input clock buffer gain programming**

110010	Gain 4, maximum gain
101010	Gain 3
100110	Gain 2
100000	Gain1, default after reset
100011	Gain 0 minimum gain

Table 15. Serial Register G

A7 – A0 (hex)	D7	D6	D5	D4	D3	D2	D1	D0
6C				<ODI> OUTPUT DATA INTERFACE - DDR LVDS OR PARALLEL CMOS			<RST> SOFTWARE RESET	

D1	<RST> Software resets the ADC
1	Resets all registers to default values
D4 — D3	<ODI> Output data interface
00	DDR LVDS outputs, default after reset
01	DDR LVDS outputs
11	Parallel CMOS outputs

Table 16. Serial Register H

A7 – A0	D7	D6	D5	D4	D3	D2	D1	D0
6D	<SCALING> POWER SCALING			<REF> INTERNAL or EXTERNAL REFERENCE				

D4	<REF> Reference
0	Internal reference
1	External reference mode, force voltage on Vcm to set reference.
D7 — D5	<SCALING> Program power scaling at lower sampling frequencies
001	Use for Fs > 150 MSPS, default after reset
011	Power Mode 1, use for 105 < Fs ≤ 150 MSPS
101	Power Mode 2, use for 50 < Fs ≤ 105
111	Power Mode 3, use for Fs ≤ 50 MSPS

Table 17. Serial Register I

A7 – A0	D7	D6	D5	D4	D3	D2	D1	D0
7E	<DATA TERM> INTERNAL TERMINATION – DATA OUTPUTS			<CLKOUT TERM> INTERNAL TERMINATION – OUTPUT CLOCK		<LVDS CURR> LVDS CURRENT PROGRAMMABILITY		

D1 — D0	<LVDS CURR> LVDS buffer current programming
00	3.5 mA, default
01	2.5 mA
10	4.5 mA
11	1.75 mA

D4 — D2	<CLKOUT TERM> LVDS internal termination for output clock pin (CLKOUT)
000	No internal termination
001	325 Ω
010	200 Ω
011	125 Ω
100	170 Ω
101	120 Ω
110	100 Ω
111	75 Ω
D7 — D5	<DATA TERM> LVDS internal termination for output data pins
000	No internal termination
001	325 Ω
010	200 Ω
011	125 Ω
100	170 Ω
101	120 Ω
110	100 Ω
111	75 Ω

Table 18. Serial Register J

A7 – A0	D7	D6	D5	D4	D3	D2	D1	D0
7F	<CURR DOUBLE> LVDS CURRENT DOUBLE							

D7 — D6	<CURR DOUBLE> LVDS buffer current double
00	Value specified by <LVDS CURR>
01	2x data, 2x clockout currents
10	1x data, 2x clockout currents
11	2x data, 4x clockout currents

PIN CONFIGURATION (LVDS MODE)

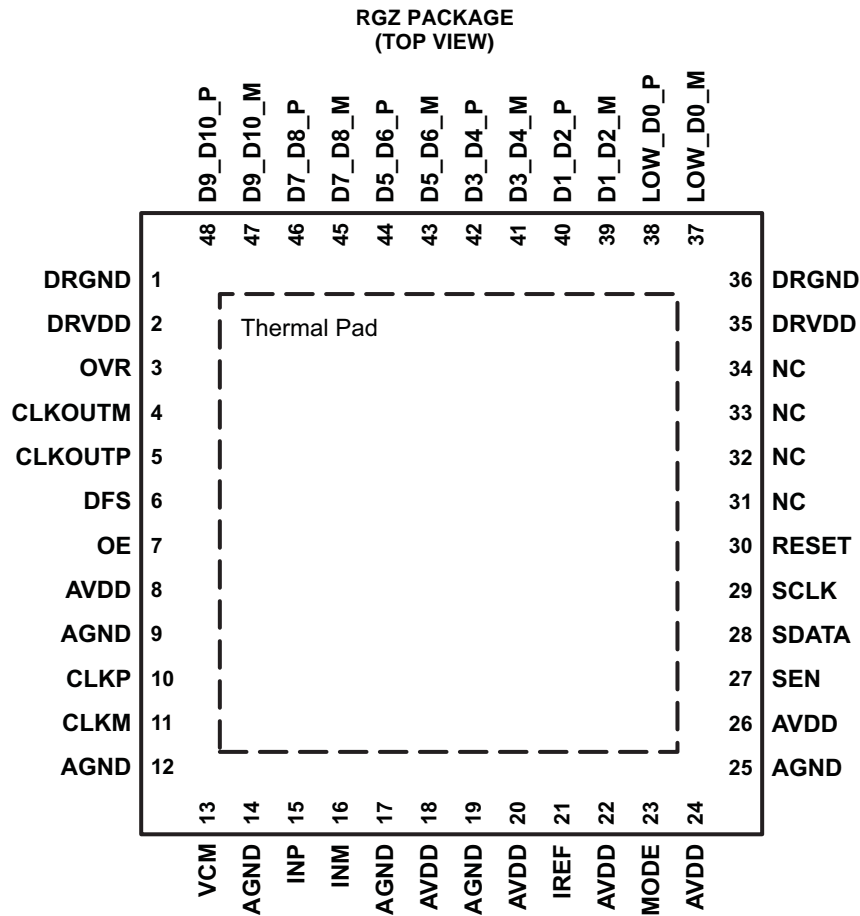

Figure 7. LVDS Mode Pinout

PIN ASSIGNMENTS – LVDS Mode

PIN NAME	DESCRIPTION	PIN TYPE	PIN NUMBER	NUMBER OF PINS
AVDD	Analog power supply	I	8, 18, 20, 22, 24, 26	6
AGND	Analog ground	I	9, 12, 14, 17, 19, 25	6
CLKP, CLKM	Differential clock input	I	10, 11	2
INP, INM	Differential analog input	I	15, 16	2
VCM	Internal reference mode – Common-mode voltage output. External reference mode – Reference input. The voltage forced on this pin sets the internal references.	I/O	13	1
IREF	Current-set resistor, 56.2-kΩ resistor to ground.	I	21	1
RESET	Serial interface RESET input. When using the serial interface mode, the user MUST initialize internal registers through hardware RESET by applying a high-going pulse on this pin, or by using the software reset option. See the <i>SERIAL INTERFACE</i> section. In parallel interface mode, the user has to tie the RESET pin permanently HIGH. (SDATA and SEN are used as parallel pin controls in this mode) The pin has an internal 100-kΩ pull-down resistor.	I	30	1

PIN ASSIGNMENTS – LVDS Mode (continued)

PIN NAME	DESCRIPTION	PIN TYPE	PIN NUMBER	NUMBER OF PINS
SCLK	This pin functions as serial interface clock input when RESET is low. It functions as LOW SPEED control pin when RESET is tied high. Tie SCLK to LOW for $F_s > 50$ MSPS and SCLK to HIGH for $F_s \leq 50$ MSPS. See Table 3 . The pin has an internal 100-k Ω pull-down resistor.	I	29	1
SDATA	This pin functions as serial interface data input when RESET is low. It functions as STANDBY control pin when RESET is tied high. See Table 4 for detailed information. The pin has an internal 100 k Ω pull-down resistor.	I	28	1
SEN	This pin functions as serial interface enable input when RESET is low. It functions as CLKOUT edge programmability when RESET is tied high. See Table 5 for detailed information. The pin has an internal 100-k Ω pull-up resistor to DRVDD.	I	27	1
OE	Output buffer enable input, active high. The pin has an internal 100-k Ω pull-up resistor to DRVDD.	I	7	1
DFS	Data Format Select input. This pin sets the DATA FORMAT (Twos complement or Offset binary) and the LVDS/CMOS output mode type. See Table 6 for detailed information.	I	6	1
MODE	Mode select input. This pin selects the Internal or External reference mode. See Table 7 for detailed information.	I	23	1
CLKOUTP	Differential output clock, true	O	5	1
CLKOUTM	Differential output clock, complement	O	4	1
LOW_D0_P	Differential output data LOW and D0 multiplexed, true	O	38	1
LOW_D0_M	Differential output data LOW and D0 multiplexed, complement	O	37	1
D1_D2_P	Differential output data D1 and D2 multiplexed, true	O	40	1
D1_D2_M	Differential output data D1 and D2 multiplexed, complement	O	39	1
D3_D4_P	Differential output data D3 and D4 multiplexed, true	O	42	1
D3_D4_M	Differential output data D3 and D4 multiplexed, complement	O	41	1
D5_D6_P	Differential output data D5 and D6 multiplexed, true	O	44	1
D5_D6_M	Differential output data D5 and D6 multiplexed, complement	O	43	1
D7_D8_P	Differential output data D7 and D8 multiplexed, true	O	46	1
D7_D8_M	Differential output data D7 and D8 multiplexed, complement	O	45	1
D9_D10_P	Differential output data D9 and D10 multiplexed, true	O	48	1
D9_D10_M	Differential output data D9 and D10 multiplexed, complement	O	47	1
OVR	Out-of-range indicator, CMOS level signal	O	3	1
DRVDD	Digital and output buffer supply	I	2, 35	2
DRGND	Digital and output buffer ground	I	1, 36	2
NC	Do not connect		31, 32, 33, 34	4
PAD	Connect the pad to the ground plane. See Board Design Considerations in application information section.		0	1

PIN CONFIGURATION (CMOS MODE)

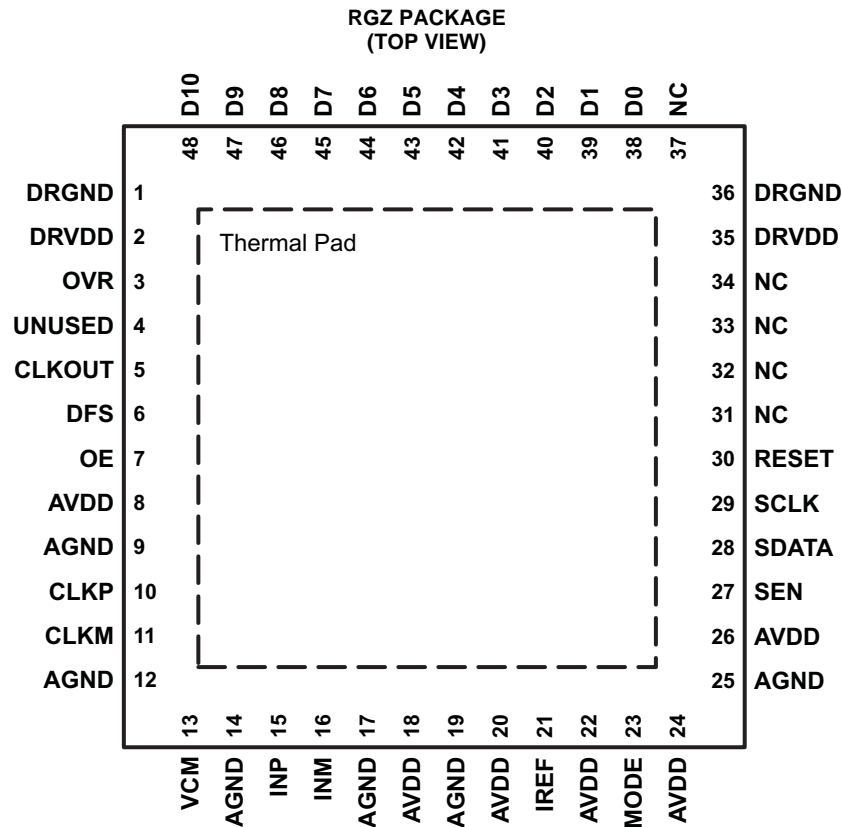

Figure 8. CMOS Mode Pinout

PIN ASSIGNMENTS – CMOS Mode

PIN NAME	DESCRIPTION	PIN TYPE	PIN NUMBER	NUMBER OF PINS
AVDD	Analog power supply	I	8, 18, 20, 22, 24, 26	6
AGND	Analog ground	I	9, 12, 14, 17, 19, 25	6
CLKP, CLKM	Differential clock input	I	10, 11	2
INP, INM	Differential analog input	I	15, 16	2
VCM	Internal reference mode – Common-mode voltage output. External reference mode – Reference input. The voltage forced on this pin sets the internal references.	I/O	13	1
IREF	Current-set resistor, 56.2-kΩ resistor to ground.	I	21	1
RESET	Serial interface RESET input. When using the serial interface mode, the user MUST initialize internal registers through hardware RESET by applying a high-going pulse on this pin, or by using the software reset option. See the <i>SERIAL INTERFACE</i> section. In parallel interface mode, the user has to tie RESET pin permanently HIGH. (SDATA and SEN are used as parallel pin controls in this mode). The pin has an internal 100-kΩ pull-down resistor.	I	30	1
SCLK	This pin functions as serial interface clock input when RESET is low. It functions as LOW SPEED control pin when RESET is tied high. Tie SCLK to LOW for $F_s > 50$ MSPS and SCLK to HIGH for $F_s \leq 50$ MSPS. See Table 3 . The pin has an internal 100-kΩ pull-down resistor.	I	29	1

PIN ASSIGNMENTS – CMOS Mode (continued)

PIN NAME	DESCRIPTION	PIN TYPE	PIN NUMBER	NUMBER OF PINS
SDATA	This pin functions as serial interface data input when RESET is low. It functions as STANDBY control pin when RESET is tied high. See Table 4 for detailed information. The pin has an internal 100 kΩ pull-down resistor.	I	28	1
SEN	This pin functions as serial interface enable input when RESET is low. It functions as CLKOUT edge programmability when RESET is tied high. See Table 5 for detailed information. The pin has an internal 100-kΩ pull-up resistor to DRVDD.	I	27	1
OE	Output buffer enable input, active high. The pin has an internal 100-kΩ pull-up resistor to DRVDD.	I	7	1
DFS	Data Format Select input. This pin sets the DATA FORMAT (Twos complement or Offset binary) and the LVDS/CMOS output mode type. See Table 6 for detailed information.	I	6	1
MODE	Mode select input. This pin selects the internal or external reference mode. See Table 7 for detailed information.	I	23	1
CLKOUT	CMOS output clock	O	5	1
D0	CMOS output data D0 (LSB)	O	38	1
D1	CMOS output data D1	O	39	1
D2	CMOS output data D2	O	40	1
D3	CMOS output data D3	O	41	1
D4	CMOS output data D4	O	42	1
D4	CMOS output data D5	O	43	1
D6	CMOS output data D6	O	44	1
D7	CMOS output data D7	O	45	1
D8	CMOS output data D8	O	46	1
D9	CMOS output data D9	O	47	1
D10	CMOS output data D10 (MSB)	O	48	1
OVR	Out-of-range indicator, CMOS level signal	O	3	1
DRVDD	Digital and output buffer supply	I	2, 35	2
DRGND	Digital and output buffer ground	I	1, 36	2
UNUSED	Unused pin in CMOS mode		4	1
NC	Do not connect		31, 32, 33, 34, 37	5
PAD	Connect the pad to the ground plane. See Board Design Considerations in application information section.		0	1

TYPICAL CHARACTERISTICS

All plots are at 25°C, AVDD = DRVDD = 3.3 V, sampling frequency = 200 MSPS, sine wave input clock, 1.5 V_{PP} differential clock amplitude, 50% clock duty cycle, -1 dBFS differential analog input, internal reference mode, 0 dB gain, DDR LVDS data output (unless otherwise noted)

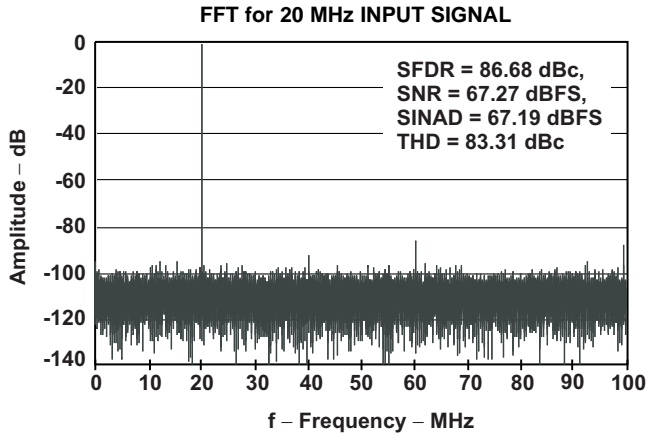

Figure 9.

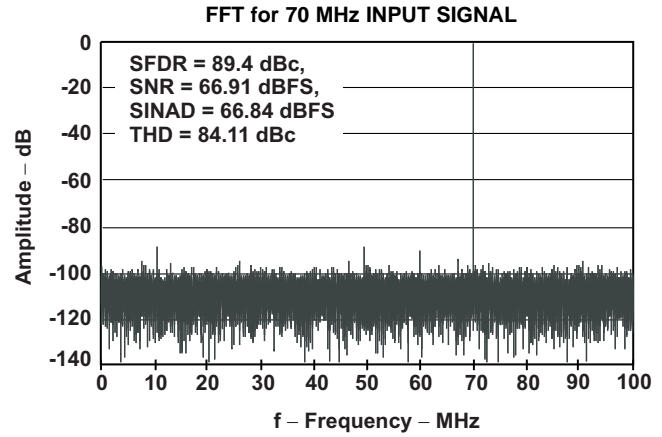

Figure 10.

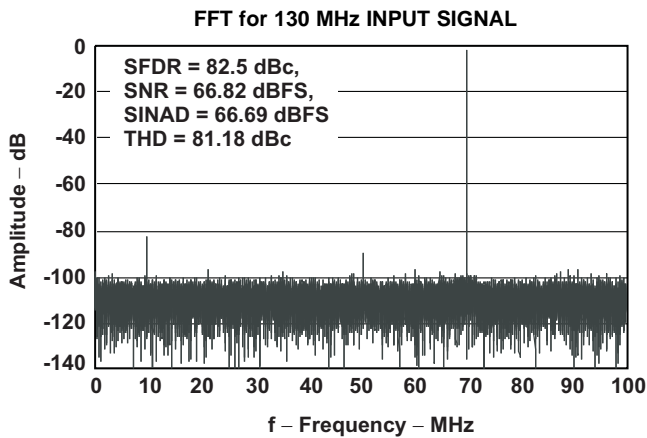

Figure 11.

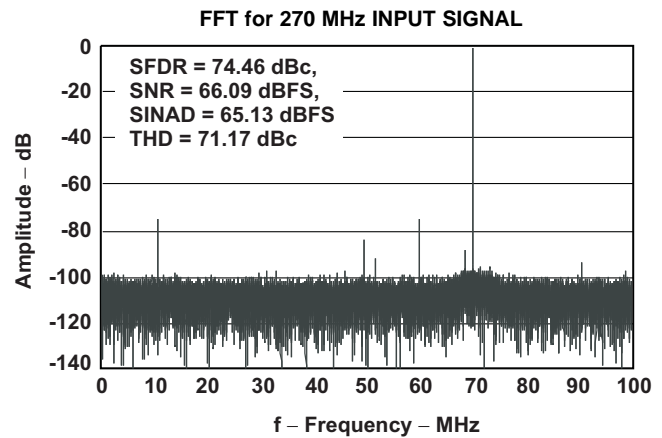

Figure 12.

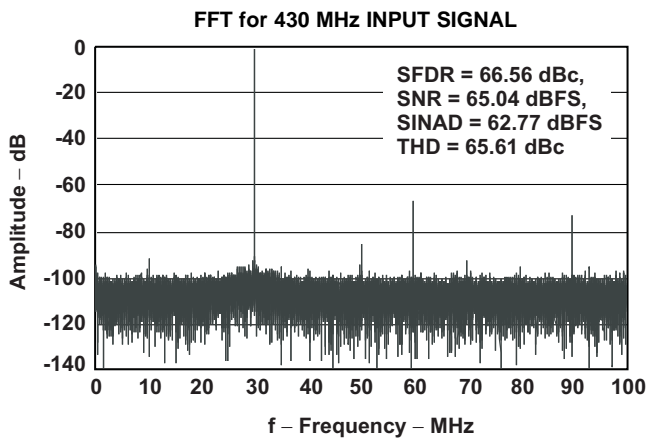

Figure 13.

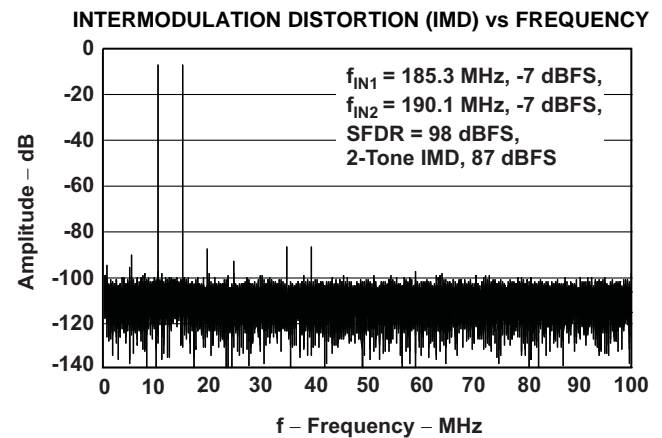

Figure 14.

TYPICAL CHARACTERISTICS (continued)

All plots are at 25°C, AVDD = DRVDD = 3.3 V, sampling frequency = 200 MSPS, sine wave input clock, 1.5 V_{PP} differential clock amplitude, 50% clock duty cycle, -1 dBFS differential analog input, internal reference mode, 0 dB gain, DDR LVDS data output (unless otherwise noted)

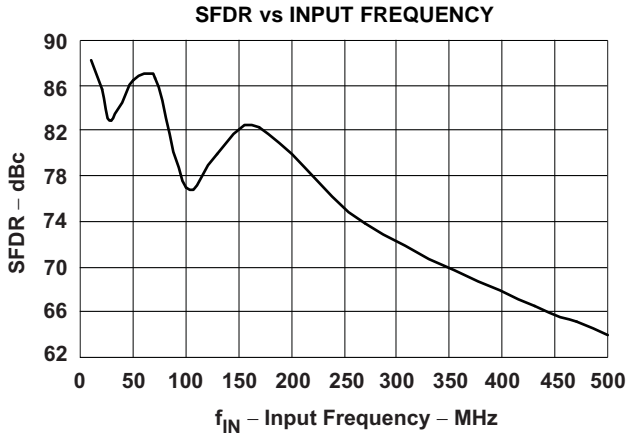

Figure 15.

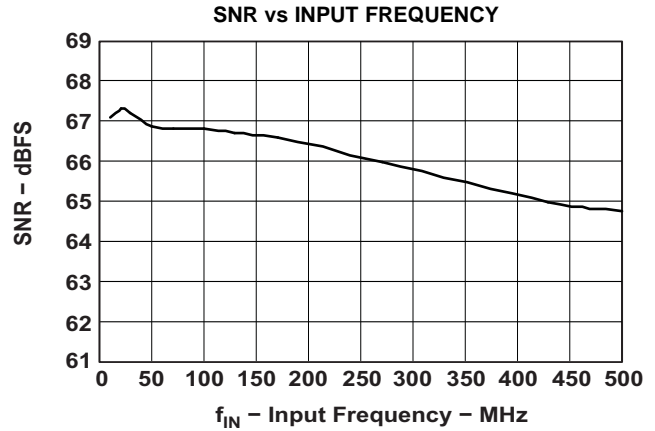

Figure 16.

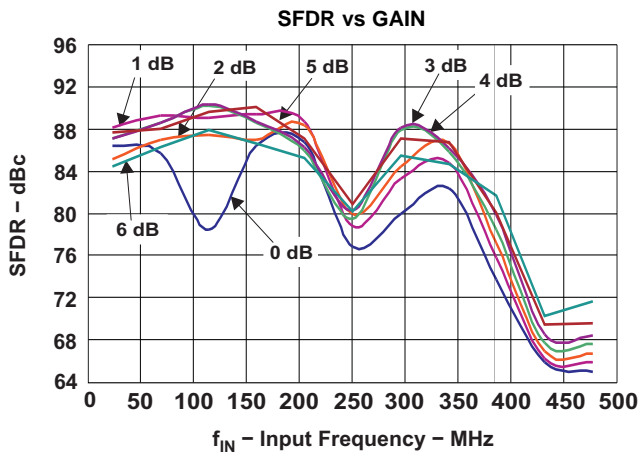

Figure 17.

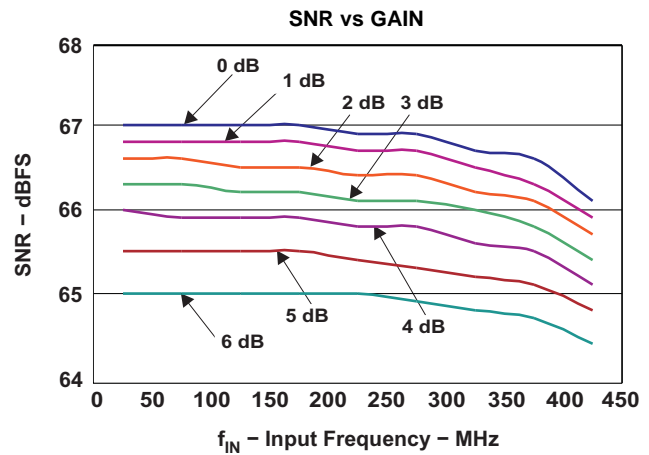

Figure 18.

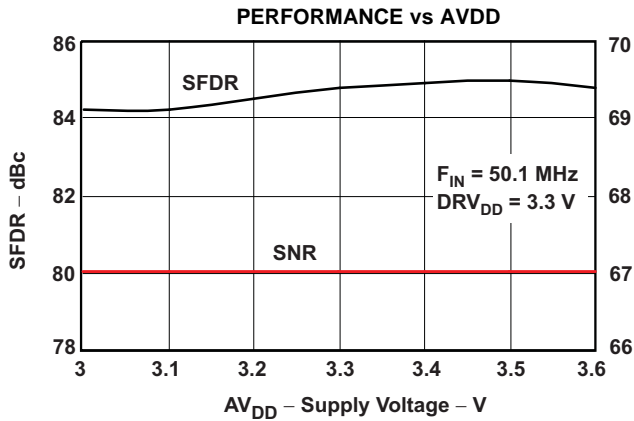

Figure 19.

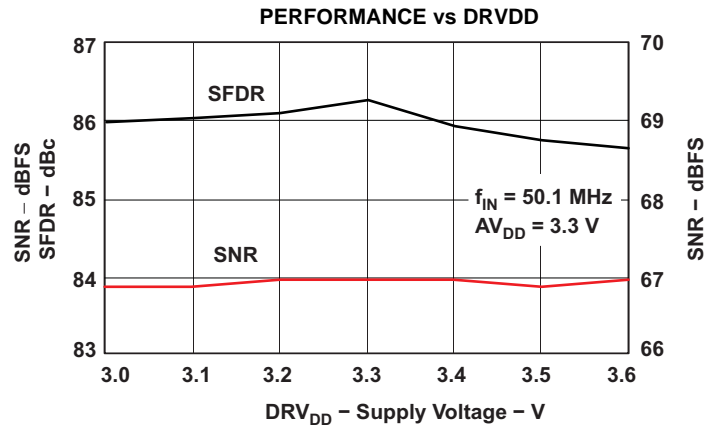

Figure 20.

TYPICAL CHARACTERISTICS (continued)

All plots are at 25°C, AVDD = DRVDD = 3.3 V, sampling frequency = 200 MSPS, sine wave input clock, 1.5 V_{PP} differential clock amplitude, 50% clock duty cycle, -1 dBFS differential analog input, internal reference mode, 0 dB gain, DDR LVDS data output (unless otherwise noted)

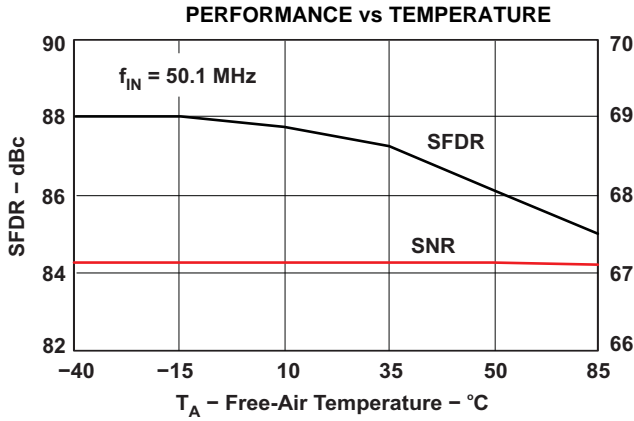

Figure 21.

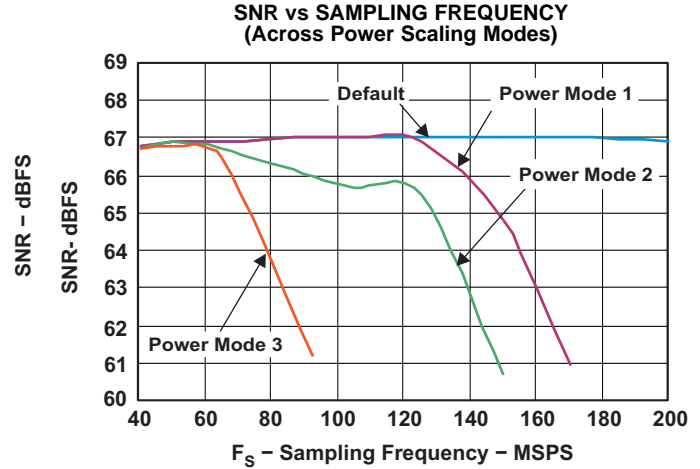

Figure 22.

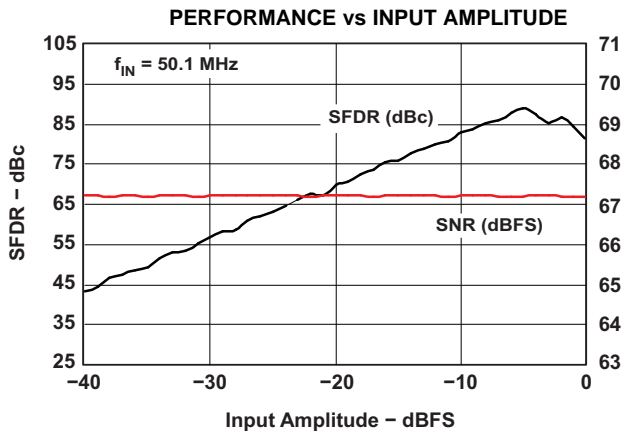

Figure 23.

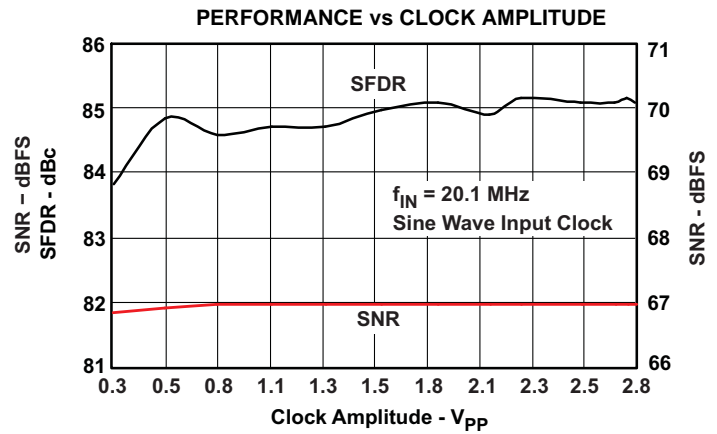

Figure 24.

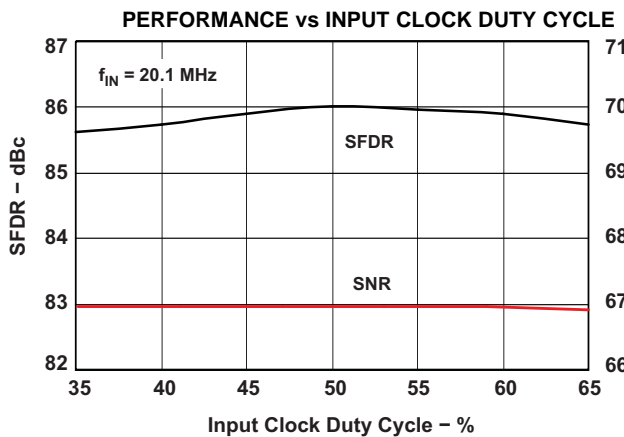

Figure 25.

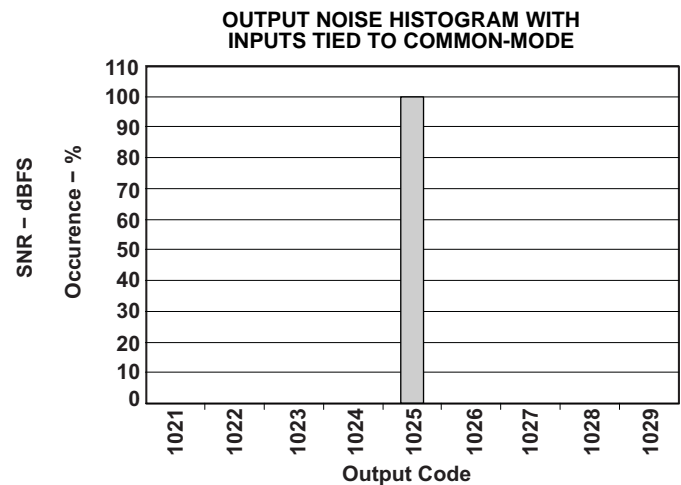

Figure 26.

TYPICAL CHARACTERISTICS (continued)

All plots are at 25°C, AVDD = DRVDD = 3.3 V, sampling frequency = 200 MSPS, sine wave input clock, 1.5 V_{PP} differential clock amplitude, 50% clock duty cycle, -1 dBFS differential analog input, internal reference mode, 0 dB gain, DDR LVDS data output (unless otherwise noted)

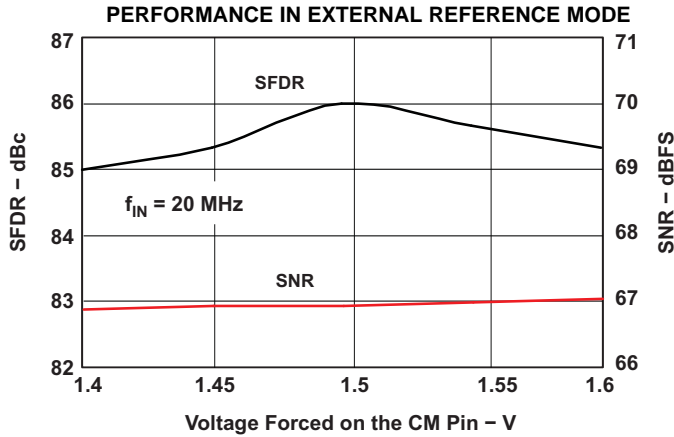

Figure 27.

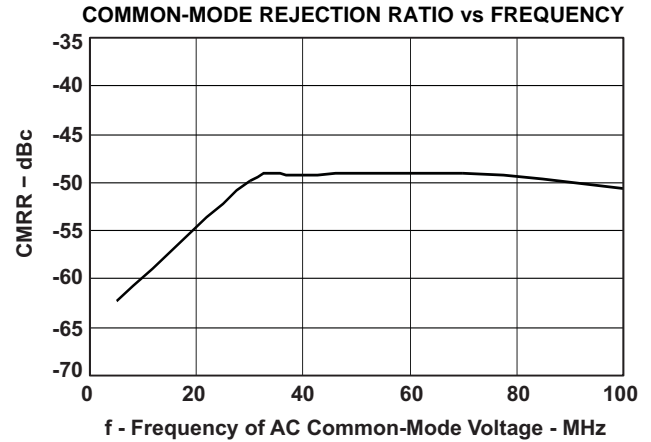

Figure 28.

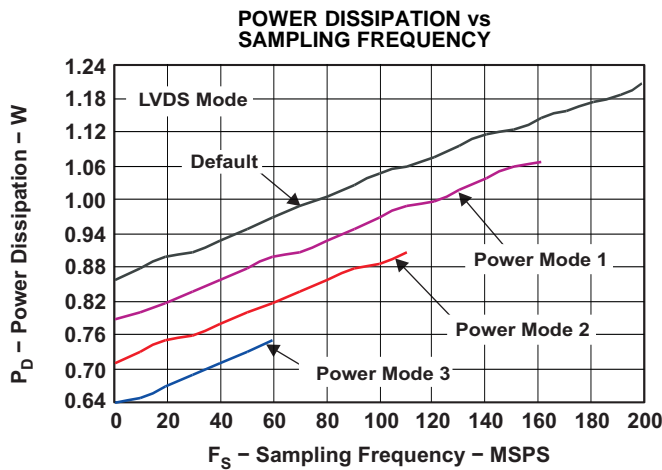

Figure 29.

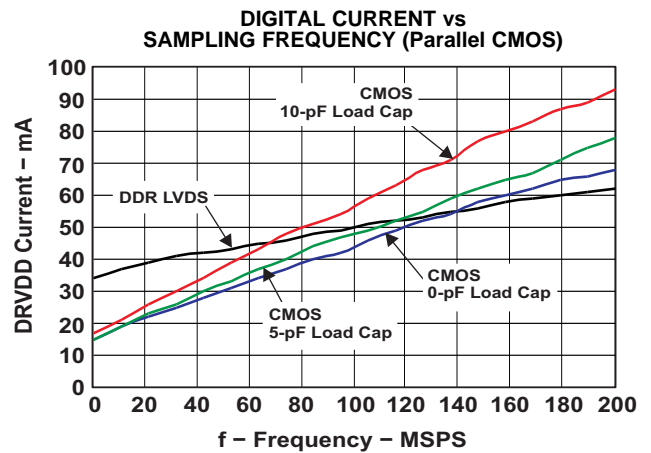

Figure 30.

TYPICAL CHARACTERISTICS (continued)

All plots are at 25°C, AVDD = DRVDD = 3.3 V, sampling frequency = 200 MSPS, sine wave input clock, 1.5 V_{PP} differential clock amplitude, 50% clock duty cycle, -1 dBFS differential analog input, internal reference mode, 0 dB gain, DDR LVDS data output (unless otherwise noted)

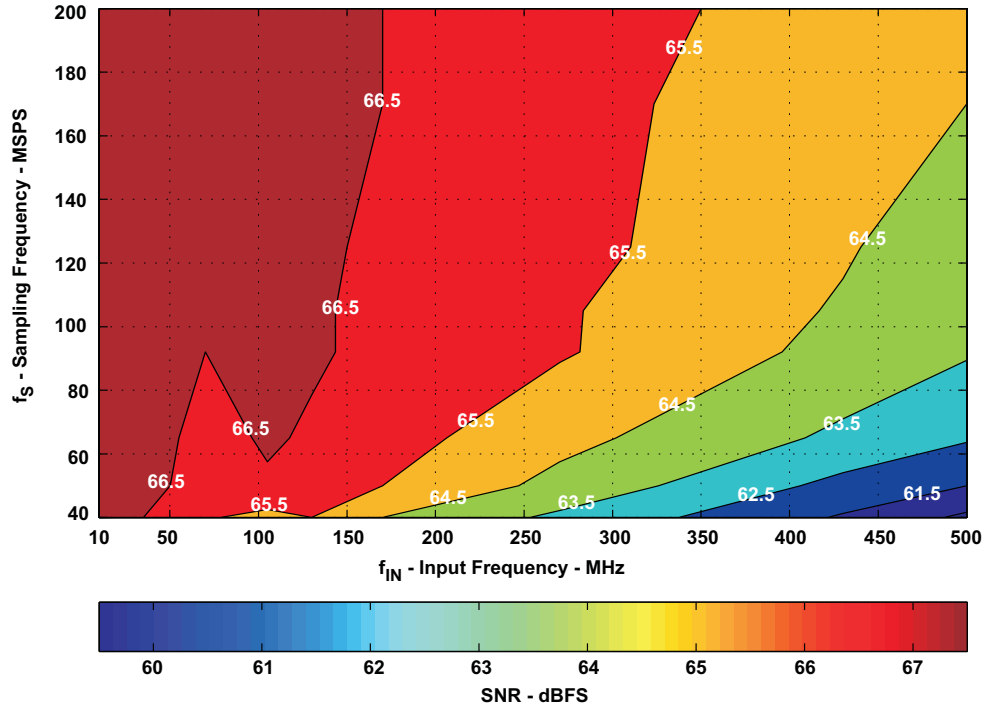

Figure 31. SNR Contour in dBFS

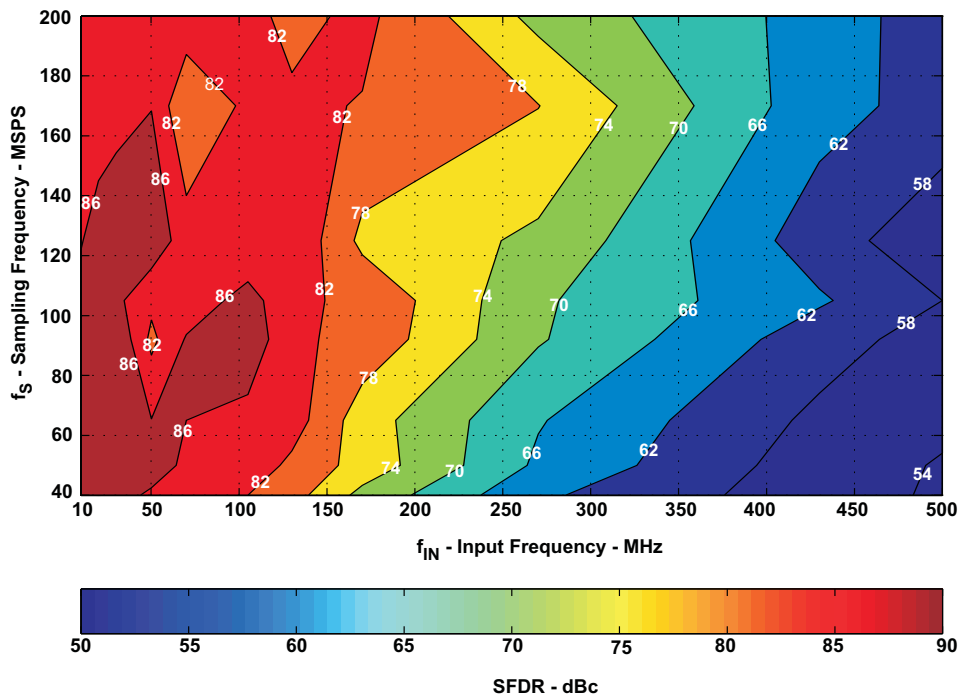

Figure 32. SFDR Contour in dBc

APPLICATION INFORMATION

THEORY OF OPERATION

ADS5517 is a low power 11-bit 200 MSPS pipeline ADC in a CMOS process. ADS5517 is based on switched capacitor technology and runs off a single 3.3-V supply. The conversion process is initiated by a rising edge of the external input clock. Once the signal is captured by the input sample and hold, the input sample is sequentially converted by a series of lower resolution stages, with the outputs combined in a digital correction logic block. At every clock edge, the sample propagates through the pipeline resulting in a data latency of 14 clock cycles. The output is available as 11-bit data, in DDR LVDS or CMOS and coded in either straight offset binary or binary 2's complement format.

ANALOG INPUT

The analog input consists of a switched-capacitor based differential sample and hold architecture, shown in [Figure 33](#).

This differential topology results in good ac-performance even for high input frequencies at high sampling rates. The INP and INM pins have to be externally biased around a common-mode voltage of 1.5 V available on VCM pin 13. For a full-scale differential input, each input pin INP, INM has to swing symmetrically between $V_{CM} + 0.5$ V and $V_{CM} - 0.5$ V, resulting in a $2\text{-}V_{PP}$ differential input swing. The maximum swing is determined by the internal reference voltages REFP (2.5 V nominal) and REFM (0.5 V, nominal).

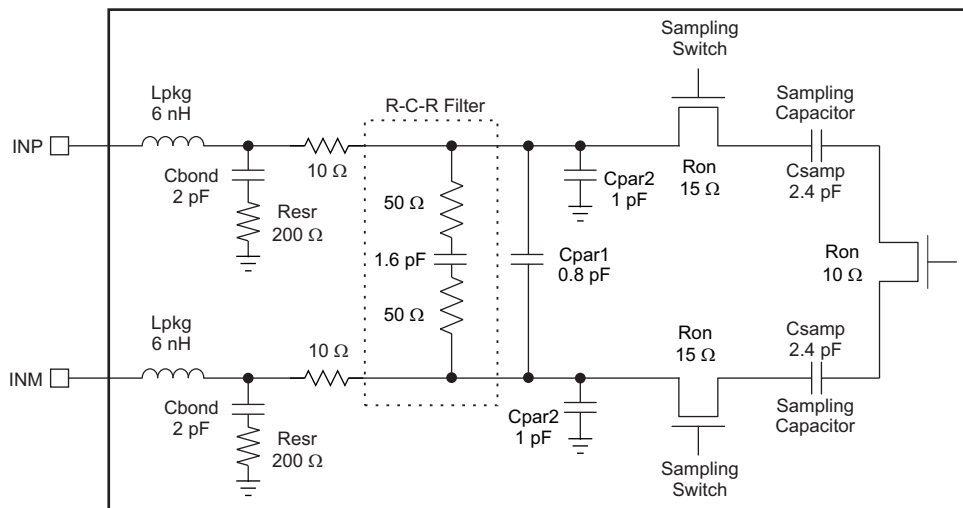

Figure 33. Input Stage

The input sampling circuit has a high 3-dB bandwidth that extends up to 800 MHz (measured from the input pins to the voltage across the sampling capacitors)

Drive Circuit Requirements

The input sampling circuit of the ADS5517 has a high 3-dB analog bandwidth of 800 MHz making it possible to sample input signals up to very high frequencies. To get best performance, it is recommended to have an external R-C-R filter across the input pins ([Figure 34](#)). This helps to filter the glitches due to the switching of the sampling capacitors. The R-C-R filter has to be designed to provide adequate filtering (for good performance) and at the same time ensure sufficient bandwidth over the desired frequency range.

In addition, it is recommended to have a 15-Ω series resistor on each input line to damp out ringing caused by the package parasitic. At higher input frequencies (> 100 MHz), a lower series resistance around 5 Ω to 10 Ω should be used. It is also necessary to present low impedance (< 50 Ω) for the common-mode switching currents. For example, this could be achieved by using two resistors from each input terminated to the common-mode voltage (V_{cm}).

Using 10-Ω series resistance and 25 Ω-3.3 pF-25 Ω as the R-C-R filter, high effective bandwidth (700 MHz) can be achieved, (see Figure 35, transfer function from the analog input pins to the voltage across the sampling capacitors).

In addition to the above ADC requirements, the drive circuit may have to be designed to provide a low insertion loss over the desired frequency range and matched impedance to the source. For this, the ADC input impedance has to be taken into account (Figure 36).

Example Drive Circuits

A suitable configuration using RF transformers and including the R-C-R filter is shown in Figure 34. Note the 15-Ω series resistors and the low common-mode impedance (using 33-Ω resistors terminated to VCM).

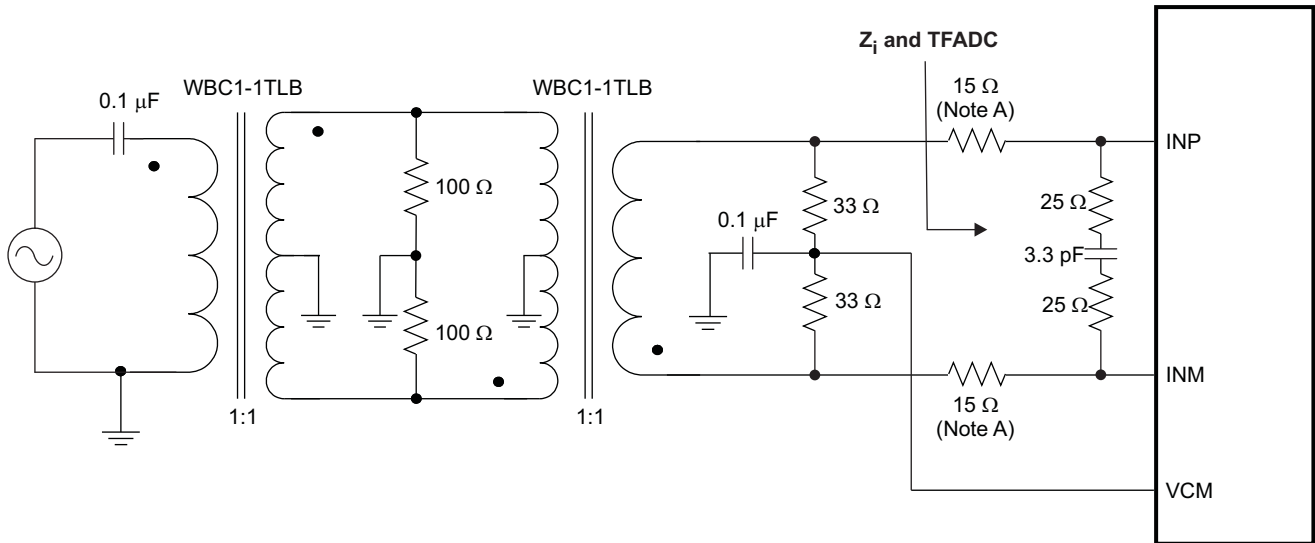

A. Use lower series resistance ($\approx 5 \Omega$ to 10Ω) at high input frequencies (> 100 MHz)

Figure 34. Example Drive Circuit With RF Transformers

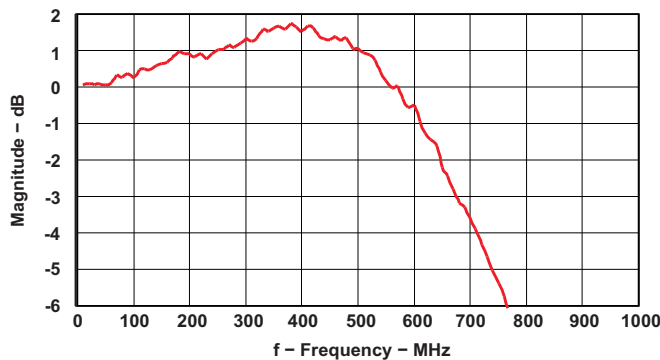

Figure 35. Analog Input Bandwidth, TFADC (Actual Silicon Data)

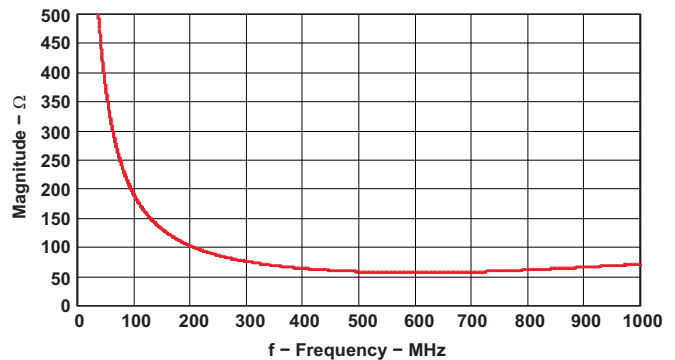

Figure 36. Input Impedance, Z_i

Using RF transformers

For optimum performance, the analog inputs have to be driven differentially. This improves the common-mode noise immunity and even order harmonic rejection. The single-ended signal is fed to the primary winding of the RF transformer. The transformer is terminated on the secondary side. Putting the termination on the secondary side helps to shield the kickbacks caused by the sampling circuit from the RF transformer's leakage inductances. The termination is accomplished by two resistors in series, with the center point connected to the 1.5 V common-mode (VCM pin 13).

At higher input frequencies, the mismatch in the transformer parasitic capacitance (between the windings) results in degraded even-order harmonic performance. Connecting two identical RF transformers back to back helps minimize this mismatch and good performance is obtained for high frequency input signals. An additional termination resistor pair (Figure 34) may be required between the two transformers to improve the balance between the P and M sides. The center point of this termination must be connected to ground. (Note that the drive circuit has to be tuned to account for this additional termination, to get the desired S11 and impedance match).

Using Differential Amplifier Drive Circuits

Figure 37 shows a drive circuit using a differential amplifier (TI's THS4509) to convert a single-ended input to differential output that can be interface to the ADC analog input pins. In addition to the single-ended to differential conversion, the amplifier also provides gain (10 dB in Figure 37). R_{FIL} helps to isolate the amplifier outputs from the switching input of the ADC. Together with C_{FIL} , it forms a low-pass filter that band-limits the noise (and signal) at the ADC input. As the amplifier output is ac-coupled, the common-mode voltage of the ADC input pins is set using two 200 Ω resistors connected to VCM.

The amplifier output can also be dc-coupled. Using the output common-mode control of the THS4509, the ADC input pins can be biased to 1.5 V. In this case, use +4 V and -1 V supplies for the THS4509 so that its output common-mode voltage (1.5 V) is at mid-supply.

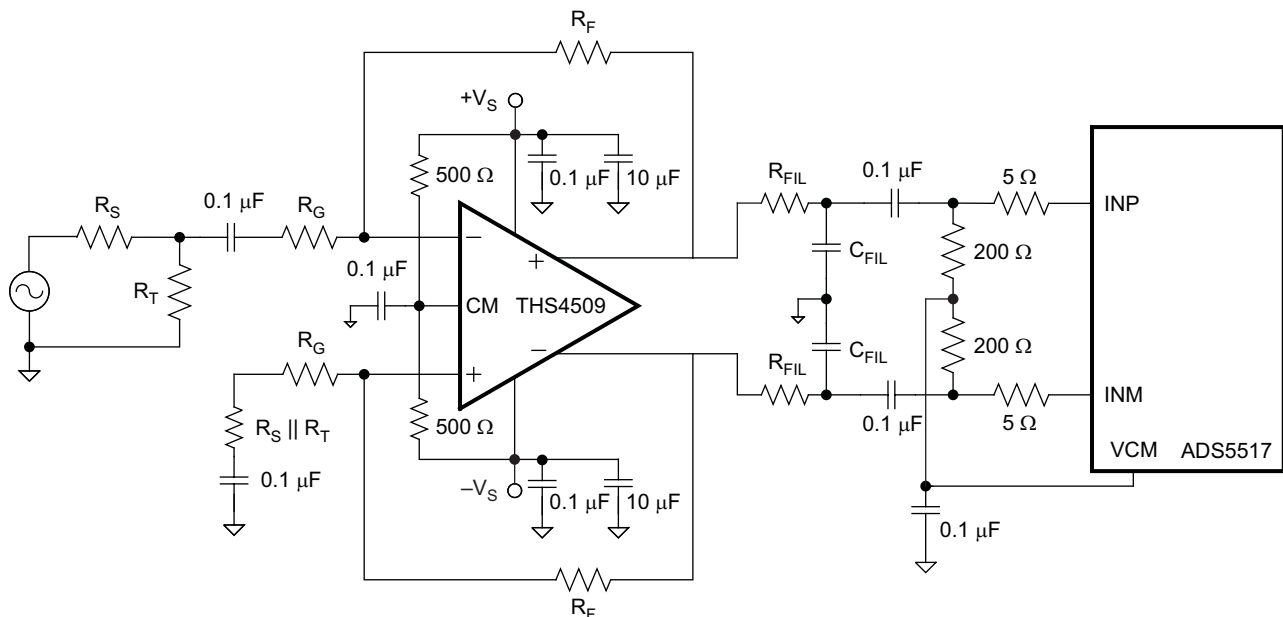

Figure 37. Drive Circuit Using the THS4509

See the EVM User Guide (SLWU028) for more information.

Input Common-Mode

To ensure a low-noise common-mode reference, the VCM pin is filtered with a 0.1- μ F low-inductance capacitor connected to ground. The VCM pin is designed to directly drive the ADC inputs. The input stage of the ADC sinks a common-mode current in the order of 342 μ A (at 200 MSPS). Equation 1 describes the dependency of the common-mode current and the sampling frequency.

$$\frac{(342 \mu\text{A}) \times F_s}{200 \text{ MSPS}} \quad (1)$$

This equation helps to design the output capability and impedance of the CM driving circuit accordingly.

Reference

ADS5517 has built-in internal references REFP and REFM, requiring no external components. Design schemes are used to linearize the converter load seen by the references; this and the integration of the requisite reference capacitors on-chip eliminates the need for external decoupling. The full-scale input range of the converter can be controlled in the external reference mode as explained below. The internal or external reference modes can be selected by controlling the MODE pin 23 (see Table 7 for details) or by programming the serial interface register bit <REF> (Table 16).

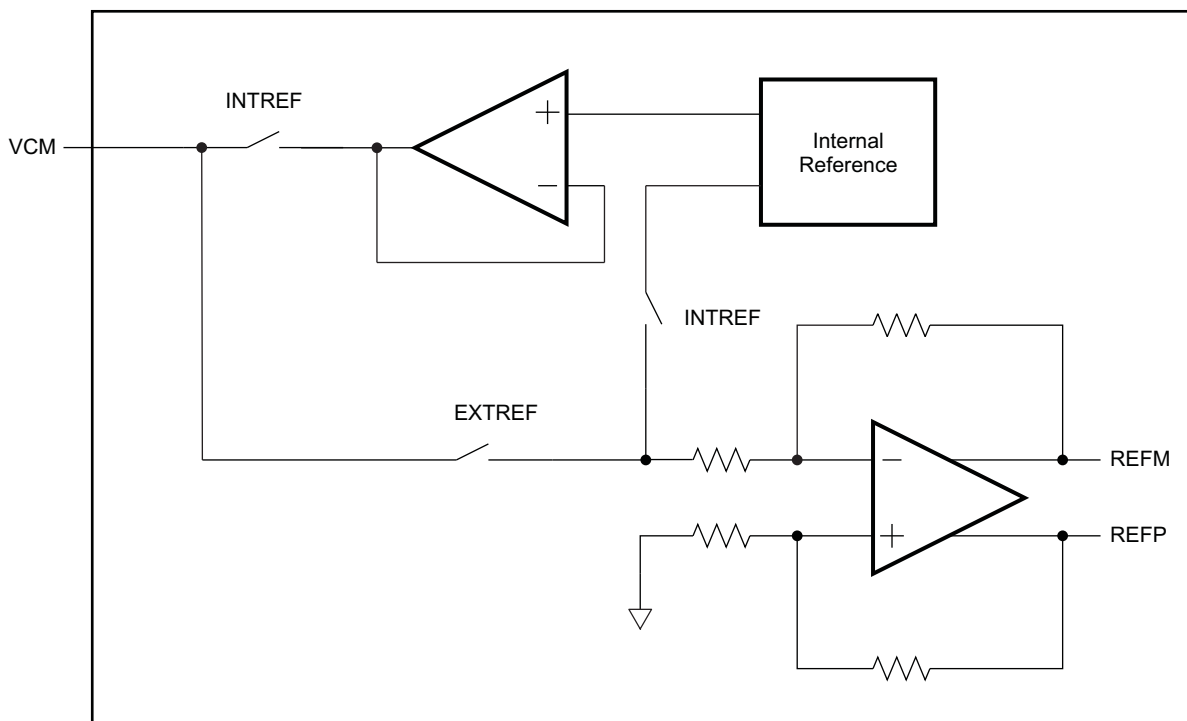

Figure 38. Reference Section

Internal Reference

When the device is in internal reference mode, the REFP and REFM voltages are generated internally. Common-mode voltage (1.5 V nominal) is output on VCM pin, which can be used to externally bias the analog input pins.

External Reference

When the device is in external reference mode, the VCM acts as a reference input pin. The voltage forced on the VCM pin is buffered and gained by 1.33 internally, generating the REFP and REFM voltages. The differential input voltage corresponding to full-scale is given by [Equation 2](#).

$$\text{Full-scale differential input } pp = (\text{Voltage forced on VCM}) \times 1.33 \quad (2)$$

In this mode, the 1.5 V common-mode voltage to bias the input pins has to be generated externally. There is no change in performance compared to internal reference mode.

Low Sampling Frequency Operation

For best performance at high sampling frequencies, ADS5517 uses a clock generator circuit to derive internal timing for the ADC. The clock generator operates from 200 MSPS down to 50 MSPS in the DEFAULT SPEED mode. The ADC enters this mode after applying reset (with serial interface configuration) or by tying SCLK pin to **low** (with parallel configuration).

For low sampling frequencies (below 50 MSPS), the ADC must be put in the LOW SPEED mode. This mode can be entered by:

- setting the register bit **<LOW SPEED>** through the serial interface, OR
- tying the SCLK pin to **high** (see [Table 3](#)) using the parallel configuration.

Clock Input

ADS5517 clock inputs can be driven differentially (SINE, LVPECL or LVDS) or single-ended (LVCMOS), with little or no difference in performance between configurations. The common-mode voltage of the clock inputs is set to VCM using internal 5-kΩ resistors as shown in [Figure 39](#). This allows the use of transformer-coupled drive circuits for sine wave clock, or ac-coupling for LVPECL, LVDS clock sources ([Figure 40](#) and [Figure 41](#))

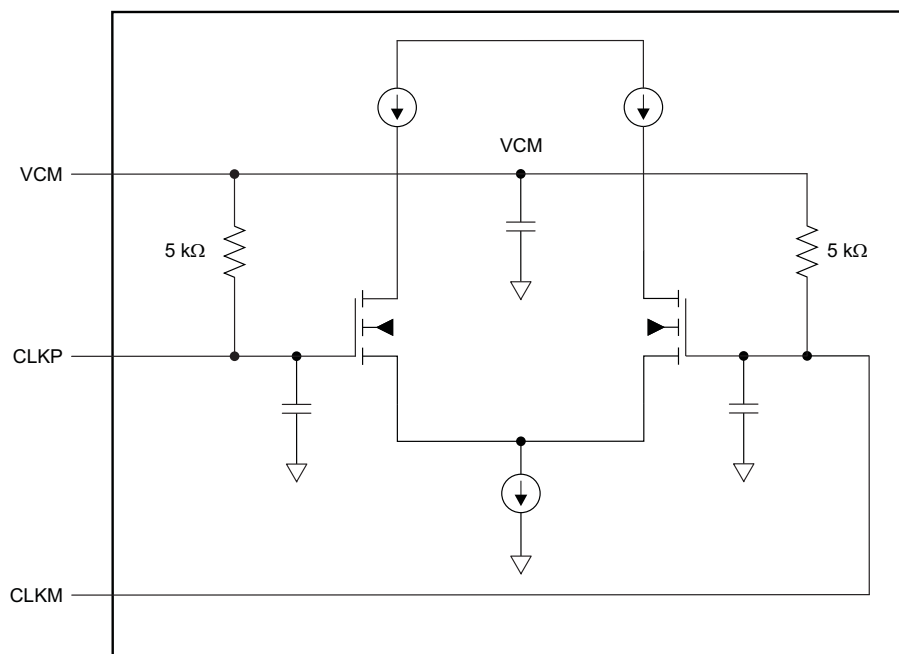

Figure 39. Internal Clock Buffer

For best performance, it is recommended to drive the clock inputs differentially, reducing susceptibility to common-mode noise. In this case, it is best to connect both clock inputs to the differential input clock signal with 0.1- μ F capacitors, as shown in [Figure 40](#).

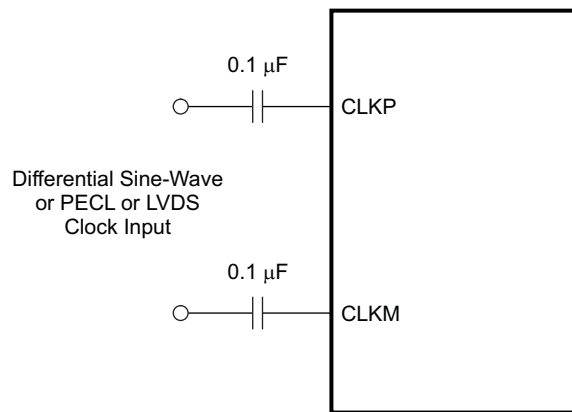

Figure 40. Differential Clock Driving Circuit

A single-ended CMOS clock can be ac-coupled to the CLKP input, with CLKM (pin 11) connected to ground with a 0.1- μ F capacitor, as shown in [Figure 41](#).

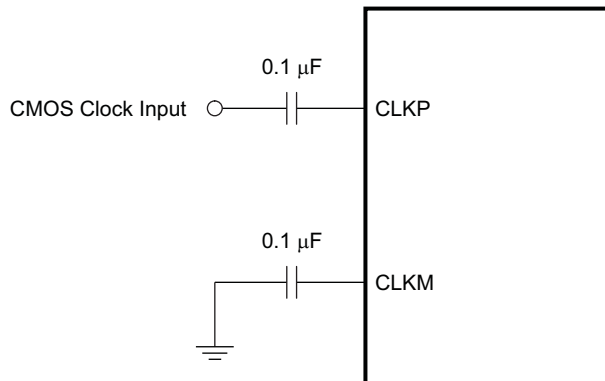

Figure 41. Single-Ended Clock Driving Circuit

For best performance, the clock inputs have to be driven differentially, reducing susceptibility to common-mode noise. For high input frequency sampling, the use a clock source with low jitter is recommended. Bandpass filtering of the clock source can help reduce the effect of jitter. There is no change in performance with a non-50% duty cycle clock input. [Figure 25](#) shows the performance variation of the ADC versus clock duty cycle

Clock Buffer Gain

When using a sinusoidal clock input, the noise contributed by clock jitter improves as the clock amplitude is increased. Therefore, using a large amplitude clock is recommended. In addition, the clock buffer has a programmable gain option to amplify the input clock. The clock buffer gain can be set by programming the register bits **<CLKIN GAIN>** ([Table 14](#)). The clock buffer gain decreases monotonically from Gain 4 to Gain 0 settings.

Programmable Gain

ADS5517 has programmable gain from 0 dB to 6 dB in steps of 1 dB. The corresponding full-scale input range varies from $2 V_{PP}$ down to $1 V_{PP}$, with 0 dB being the default gain. At high IF, this is especially useful as the SFDR improvement is significant with marginal degradation in SNR.

The gain can be programmed using the serial interface (bits D3-D0 in register 0x68).

Power Down

ADS5517 has three power-down modes – global STANDBY, output buffer disabled, and input clock stopped.

Global STANDBY

This mode can be initiated by controlling SDATA (pin 28) or by setting the register bit **<STBY>** (Table 10) through the serial interface. In this mode, the A/D converter, reference block and the output buffers are powered down and the total power dissipation reduces to about 100 mW. The output buffers are in high impedance state. The wake-up time from the global power down to data becoming valid normal mode is maximum 100 μ s.

Output Buffer Disable

The output buffers can be disabled using OE pin 7 in both the LVDS and CMOS modes, reducing the total power by about 100 mW. With the buffers disabled, the outputs are in high impedance state. The wake-up time from this mode to data becoming valid in normal mode is maximum 1 μ s in LVDS mode and 50 ns in CMOS mode.

Input Clock Stop

The converter enters this mode when the input clock frequency falls below 1 MSPS. The power dissipation is about 100 mW and the wake-up time from this mode to data becoming valid in normal mode is maximum 100 μ s.

Power Scaling Modes

ADS5517 has a power scaling mode in which the device can be operated at reduced power levels at lower sampling frequencies with no difference in performance. (See [Figure 29](#))⁽¹⁾ There are four power scaling modes for different sampling clock frequency ranges, using the serial interface register bits **<SCALING>** ([Table 16](#)). Only the AVDD power is scaled, leaving the DRVDD power unchanged.

Table 19. Power Scaling vs Sampling Speed

Sampling Frequency MSPS	Power Scaling Mode	Analog Power (Typical)	Analog Power in Default Mode
> 150	Default	1010 mW at 200 MSPS	1010 mW at 200 MSPS
105 to 150	Power Mode 1	841 mW at 150 MSPS	917 mW at 150 MSPS
50 to 105	Power Mode 2	670 mW at 105 MSPS	830 mW at 105 MSPS
< 50	Power Mode 3	525 mW at 50 MSPS	760 mW at 50 MSPS

(1) The performance in the power scaling modes is from characterization and not tested in production.

Power Supply Sequence

During power-up, the AVDD and DRVDD supplies can come up in any sequence. The two supplies are separated inside the device. Externally, AVDD and DRVDD can be driven from separate supplies or from a single supply.

Digital Output Information

ADS5517 provides 11-bit data, an output clock synchronized with the data and an out-of-range indicator that goes high when the output reaches the full-scale limits. In addition, output enable control (OE pin 7) is provided to power down the output buffers and put the outputs in high-impedance state.

Output Interface

Two output interface options are available – Double Data Rate (DDR) LVDS and parallel CMOS. The options are selected using the DFS (see [Table 6](#)) or the serial interface register bit **<ODI>** ([Table 15](#)).

DDR LVDS Outputs

In this mode, the 11 data bits and the output clock are available as LVDS (Low Voltage Differential Signal) levels. Two successive data bits are multiplexed and output on each LVDS differential pair as shown in [Figure 42](#). So, there are 6 LVDS output pairs for the 11 data bits and 1 LVDS output pair for the output clock.

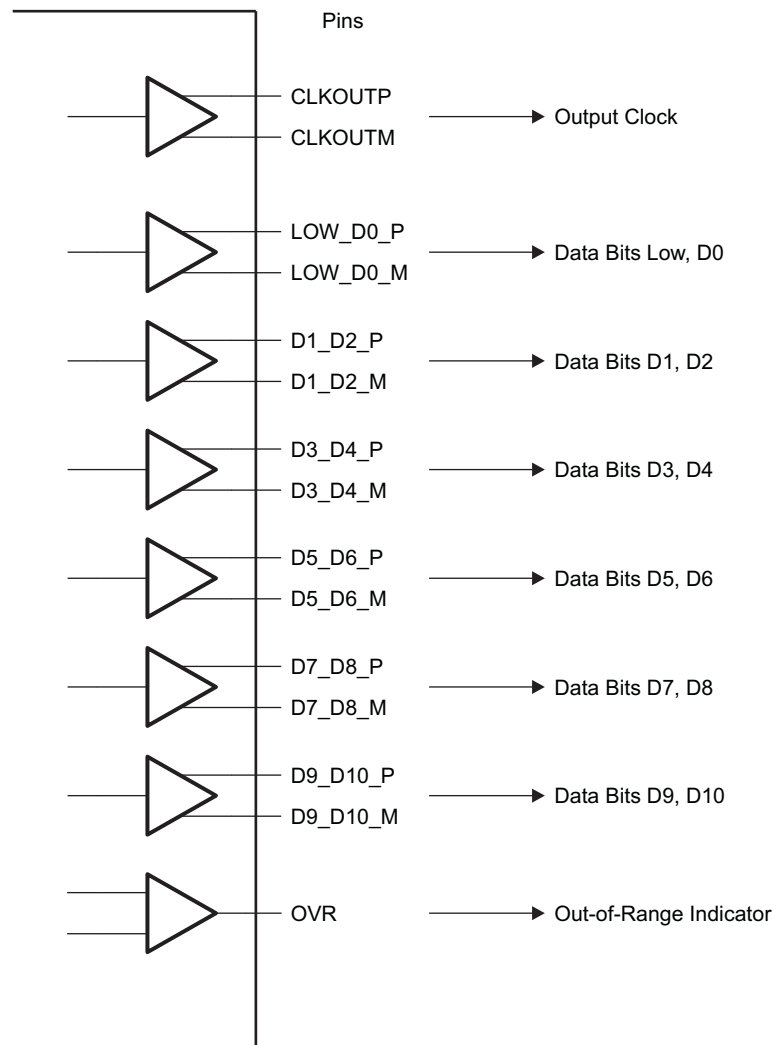

Figure 42. DDR LVDS Outputs

Even data bits D0, D2, D4, D6, D8, and D10 are output at the rising edge of CLKOUTP and the odd data bits D1, D3, D5, D7, and D9 are output at the falling edge of CLKOUTP. Both the rising and falling edges of CLKOUTP must be used to capture all the 11 data bits (see [Figure 43](#)).

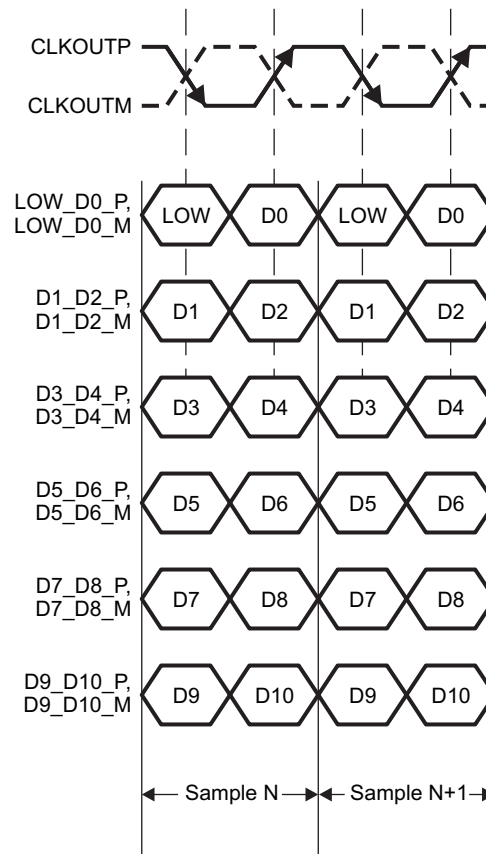

Figure 43. DDR LVDS Interface

LVDS Buffer Current Programmability

The default LVDS buffer output current is 3.5 mA. When terminated by 100 Ω , the results is a 350-mV single-ended voltage swing (700-mV_{PP} differential swing). The LVDS buffer currents can also be programmed to 2.5 mA, 4.5 mA, and 1.75 mA using the register bits **<LVDS CURR>** (Table 17). In addition, there exists a current double mode, where this current is doubled for the data and output clock buffers (register bits **<CURR DOUBLE>**, Table 18).

LVDS Buffer Internal Termination

An internal termination option is available (using the serial interface), by which the LVDS buffers are differentially terminated inside the device. The termination resistances available are – 325, 200, and 170 Ω (nominal with $\pm 20\%$ variation). Any combination of these three terminations can be programmed; the effective termination is the parallel combination of the selected resistances. This results in eight effective terminations from open (no termination) to 75 Ω .

The internal termination helps to absorb any reflections coming from the receiver end, improving the signal integrity. With 100- Ω internal and 100- Ω external termination, the voltage swing at the receiver end is halved (compared to no internal termination). The voltage swing can be restored by using the LVDS current double mode. Figure 44 shows the eye diagram of one of the LVDS data outputs with a 10-pF load capacitance (from each pin to ground) and 100- Ω internal termination enabled. The termination can be programmed using register bits **<DATA TERM>** and **<CLKOUT TERM>** (Table 17).

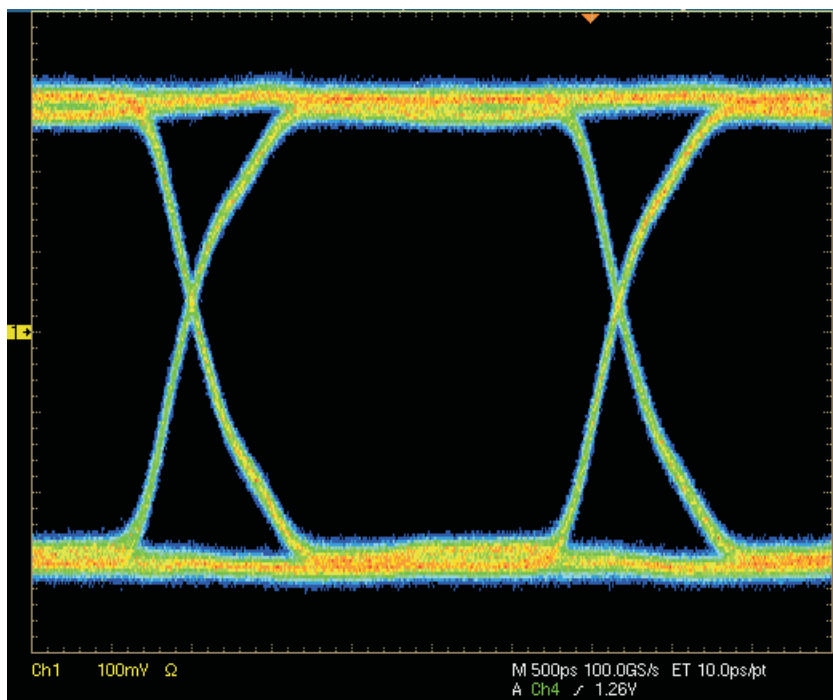

Figure 44. Eye Diagram of LVDS Data Output With Internal Termination

Parallel CMOS

In this mode, the 11 data outputs and the output clock are available as 3.3-V CMOS voltage levels. Each data bit and the output clock is available on a separate pin in parallel. By default, the data outputs are valid during the rising edge of the output clock. The output clock is CLKOUT (pin 5).

CMOS Mode Power Dissipation

With CMOS outputs, the DRVDD current scales with the sampling frequency and the load capacitance on every output pin (see Figure 30). The maximum DRVDD current occurs when each output bit toggles between 0 and 1 every clock cycle. In actual applications, this condition is unlikely to occur. The actual DRVDD current is determined by the average number of output bits switching, which is a function of the sampling frequency and the nature of the analog input signal.

$$\text{Digital current due to CMOS output switching} = C_L \times V_{\text{DRVDD}} \times (N \times F_{\text{AVG}})$$

where C_L = load capacitance, $N \times F_{\text{AVG}}$ = average number of output bits switching

Figure 30 shows the current with various load capacitances across sampling frequencies at 2MHz analog input frequency.

Output Switching Noise and Data Position Programmability (in CMOS mode ONLY)

Switching noise (caused by CMOS output data transitions) can couple into the analog inputs during the instant of sampling and degrade the SNR. To minimize this, the device includes programmable options to move the output data transitions with respect to the output clock. This can be used to position the data transitions at the optimum place away from the sampling instant and improve the SNR. Figure 30 shows the variation of SNR for different CMOS output data positions at 200 MSPS.

Note that the optimum output data position varies with the sampling frequency. The data position can be programmed using the register bits <DATA POSN> (Table 9).

It is recommended to put series resistors (50 to 100 Ω) on each output line placed close to the converter pins. This helps to isolate the outputs from seeing large load capacitances and in turn reduces the amount of switching noise. For example, the data in Figure 30 was taken with 50- Ω resistors on each output line.

Output Clock Position Programmability

In both the LVDS and CMOS modes, the output clock can be moved around its default position. This can be done using SEN pin 27 (as described in Table 5) or using the serial interface register bits <CLKOUT POSN> (Table 9). Using this allows to trade-off the setup and hold times leading to reliable data capture. There also exists an option to align the output clock edge with the data transition.

Note that programming the output clock position also affects the clock propagation delay times.

Output Data Format

Two output data formats are supported – 2's complement and offset binary. They can be selected using the DFS (pin 6) or the serial interface register bit <DF> (Table 10).

Out-of-Range Indicator (OVR)

When the input voltage exceeds the full-scale range of the ADC, OVR (pin 3) goes high, and the output code is clamped to the appropriate full-scale level for the duration of the overload. For a positive overdrive, the output code is 0x7FF in offset binary output format, and 0x3FF in 2's complement output format. For a negative input overdrive, the output code is 0x000 in offset binary output format and 0x400 in 2's complement output format. Figure 45 shows the behavior of OVR during the overload. Note that OVR and the output code react to the overload after a latency of 14 clock cycles.

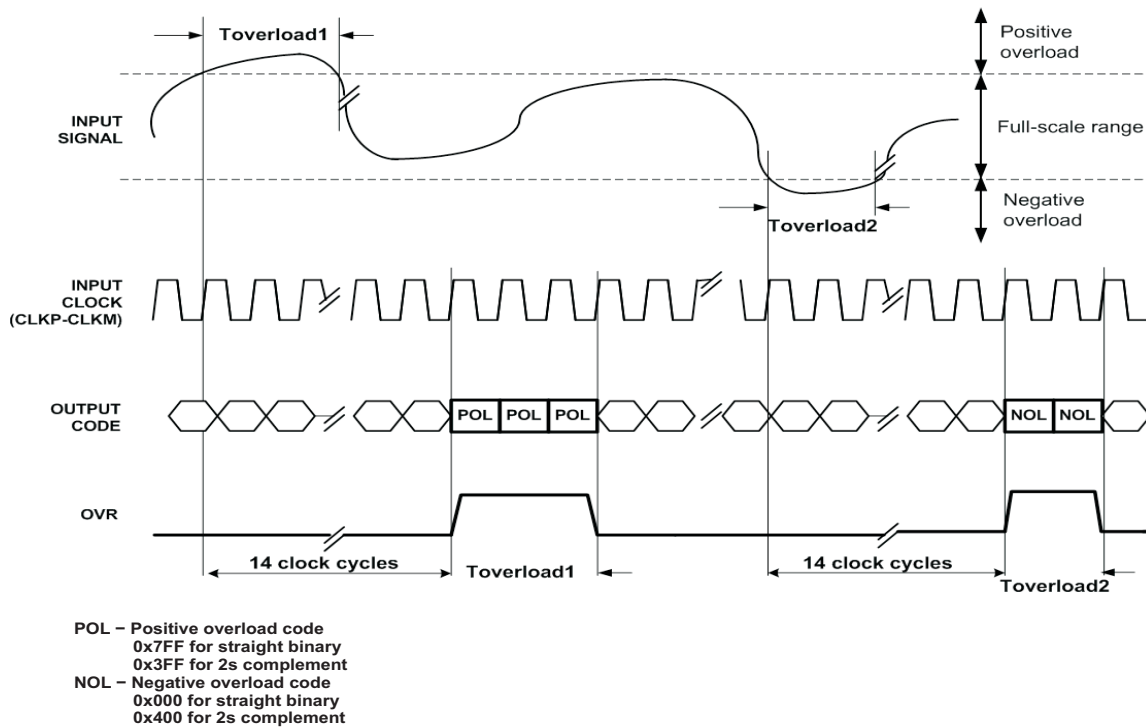

Figure 45. OVR During Input Overvoltage

Output Timing

For the best performance at high sampling frequencies, ADS5517 uses a clock generator circuit to derive internal timing for ADC. This results in optimal setup and hold times of the output data and 50% output clock duty cycle for sampling frequencies from 80 MSPS to 200 MSPS. See Table 20 for timing information above 80 MSPS.

Table 20. Timing Characteristics (80 MSPS to 200 MSPS) ⁽¹⁾

Fs, MSPS	t _{su} DATA SETUP TIME, ns			t _h DATA HOLD TIME, ns			t _{pDl} CLOCK PROPAGATION DELAY, ns		
	MIN	TYP	MAX	MIN	TYP	MAX	MIN	TYP	MAX
DDR LVDS									
190	1.2	1.7		0.4	0.9		4.0	4.7	5.4
170	1.3	1.8		0.5	1.0		3.9	4.6	5.3
150	1.6	2.1		0.6	1.1		4.3	5.0	5.7
130	2.0	2.5		0.8	1.3		4.5	5.2	5.9
80	3.6	4.1		1.6	2.1		4.7	5.7	6.7
PARALLEL CMOS									
190	2.2	3.0		0.5	0.9		2.4	3.2	4.0
170	2.5	3.3		0.8	1.2		1.9	2.7	3.5
150	2.8	3.6		1.2	1.6		1.7	2.5	3.3
130	3.3	4.1		1.7	2.1		1.1	1.9	2.7
80	6.0	7.0		3.7	4.1		10.8	12	13.2

(1) Timing parameters are specified by design and characterization and not tested in production.

Below 80 MSPS, the setup and hold times do not scale with the sampling frequency. The output clock duty cycle also progressively moves away from 50% as the sampling frequency is reduced from 80 MSPS.

See [Table 21](#) for timings at sampling frequencies below 80 MSPS. [Figure 46](#) shows the clock duty cycle across sampling frequencies in the DDR LVDS and CMOS modes.

Table 21. Timing Characteristics (1 MSPS to 80 MSPS) ⁽¹⁾

Fs, MSPS	t _{su} DATA SETUP TIME, ns			t _h DATA HOLD TIME, ns			t _{pDl} CLOCK PROPAGATION DELAY, ns		
	MIN	TYP	MAX	MIN	TYP	MAX	MIN	TYP	MAX
DDR LVDS									
1 to 80	3.6			1.6				5.7	
PARALLEL CMOS									
1 to 80	6			3.7				12	

(1) Timing parameters are specified by design and characterization and not tested in production.

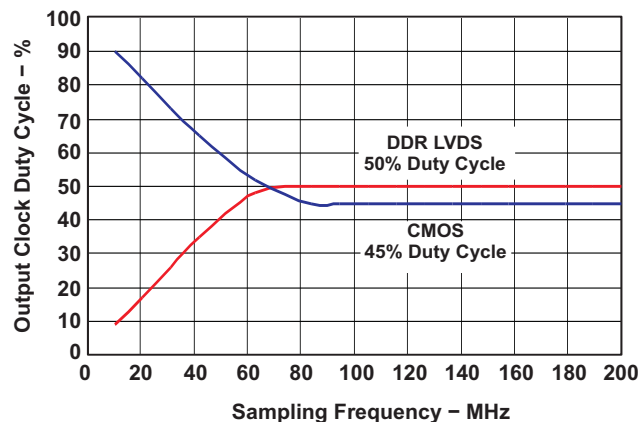

Figure 46. Output Clock Duty Cycle (Typical) vs Sampling Frequency

The latency of ADS5517 is 14 clock cycles from the sampling instant (input clock rising edge). In the LVDS mode, the latency remains constant across sampling frequencies. In the CMOS mode, the latency is 14 clock cycles above 80 MSPS and 13 clock cycles below 80 MSPS.

Board Design Considerations

Grounding

A single ground plane is sufficient to give good performance, provided the analog, digital and clock sections of the board are cleanly partitioned. See the EVM User Guide ([SLWU028](#)) for details on layout and grounding.

Supply Decoupling

As the ADS5517 already includes internal decoupling, minimal external decoupling can be used without loss in performance. Note that decoupling capacitors can help to filter external power supply noise, so the optimum number of capacitors would depend on the actual application. The decoupling capacitors should be placed close to the converter supply pins.

It is recommended to use separate supplies for the analog and digital supply pins to isolate digital switching noise from sensitive analog circuitry. If only a single 3.3V supply is available, it should be routed first to AVDD. It can then be tapped and isolated with a ferrite bead (or inductor) with decoupling capacitor, before being routed to DRVDD.

Series Resistors on Data Outputs

It is recommended to put series resistors (50 to 100 Ω) on each output line placed close to the converter pins. This helps to isolate the outputs from seeing large load capacitances and in turn reduces the amount of switching noise.

Exposed Thermal Pad

It is necessary to solder the exposed pad at the bottom of the package to a ground plane for best thermal performance. For detailed information, see application notes **QFN Layout Guidelines** ([SLOA122](#)) and **QFN/SON PCB Attachment** ([SLUA271](#)).

DEFINITION OF SPECIFICATIONS

Analog Bandwidth

The analog input frequency at which the power of the fundamental is reduced by 3 dB with respect to the low frequency value.

Aperture Delay

The delay in time between the rising edge of the input sampling clock and the actual time at which the sampling occurs.

Aperture Uncertainty (Jitter)

The sample-to-sample variation in aperture delay.

Clock Pulse Width/Duty Cycle

The duty cycle of a clock signal is the ratio of the time the clock signal remains at a logic high (clock pulse width) to the period of the clock signal. Duty cycle is typically expressed as a percentage. A perfect differential sine-wave clock results in a 50% duty cycle.

Maximum Conversion Rate

The maximum sampling rate at which certified operation is given. All parametric testing is performed at this sampling rate unless otherwise noted.

Minimum Conversion Rate

The minimum sampling rate at which the ADC functions.

Differential Nonlinearity (DNL)

An ideal ADC exhibits code transitions at analog input values spaced exactly 1 LSB apart. The DNL is the deviation of any single step from this ideal value, measured in units of LSBs

Integral Nonlinearity (INL)

The INL is the deviation of the ADC's transfer function from a best fit line determined by a least squares curve fit of that transfer function, measured in units of LSBs.

Gain Error

The gain error is the deviation of the ADC's actual input full-scale range from its ideal value. The gain error is given as a percentage of the ideal input full-scale range.

Offset Error

The offset error is the difference, given in number of LSBs, between the ADC's actual average idle channel output code and the ideal average idle channel output code. This quantity is often mapped into mV.

Temperature Drift

The temperature drift coefficient (with respect to gain error and offset error) specifies the change per degree Celsius of the parameter from T_{MIN} to T_{MAX} . It is calculated by dividing the maximum deviation of the parameter across the T_{MIN} to T_{MAX} range by the difference $T_{\text{MAX}} - T_{\text{MIN}}$.

Signal-to-Noise Ratio

SNR is the ratio of the power of the fundamental (P_S) to the noise floor power (P_N), excluding the power at dc and the first nine harmonics.

$$\text{SNR} = 10\text{Log}_{10} \frac{P_S}{P_N} \quad (4)$$

SNR is either given in units of dBc (dB to carrier) when the absolute power of the fundamental is used as the reference, or dBFS (dB to full scale) when the power of the fundamental is extrapolated to the converter's full-scale range.

Signal-to-Noise and Distortion (SINAD)

SINAD is the ratio of the power of the fundamental (P_S) to the power of all the other spectral components including noise (P_N) and distortion (P_D), but excluding dc.

$$\text{SINAD} = 10\text{Log}_{10} \frac{P_S}{P_N + P_D} \quad (5)$$

SINAD is either given in units of dBc (dB to carrier) when the absolute power of the fundamental is used as the reference, or dBFS (dB to full scale) when the power of the fundamental is extrapolated to the converter's full-scale range.

Effective Number of Bits (ENOB)

The ENOB is a measure of a converter's performance as compared to the theoretical limit based on quantization noise.

$$\text{ENOB} = \frac{\text{SINAD} - 1.76}{6.02} \quad (6)$$

Total Harmonic Distortion (THD)

THD is the ratio of the power of the fundamental (P_S) to the power of the first nine harmonics (P_D).

$$\text{THD} = 10\text{Log}_{10} \frac{P_S}{P_D} \quad (7)$$

THD is typically given in units of dBc (dB to carrier).

Spurious-Free Dynamic Range (SFDR)

The ratio of the power of the fundamental to the highest other spectral component (either spur or harmonic). SFDR is typically given in units of dBc (dB to carrier).

Two-Tone Intermodulation Distortion

IMD3 is the ratio of the power of the fundamental (at frequencies f_1 and f_2) to the power of the worst spectral component at either frequency $2f_1 - f_2$ or $2f_2 - f_1$. IMD3 is either given in units of dBc (dB to carrier) when the absolute power of the fundamental is used as the reference, or dBFS (dB to full scale) when the power of the fundamental is extrapolated to the converter's full-scale range.

DC Power Supply Rejection Ratio (DC PSRR)

The DC PSRR is the ratio of the change in offset error to a change in analog supply voltage. The DC PSRR is typically given in units of mV/V.

AC Power Supply Rejection Ratio (AC PSRR)

AC PSRR is the measure of rejection of variations in the supply voltage of the ADC. If ΔV_{SUP} is the change in the supply voltage and ΔV_{OUT} is the resultant change in the ADC output code (referred to the input), then

$$\text{PSRR} = 20\text{Log}^{10} \frac{\Delta V_{\text{OUT}}}{\Delta V_{\text{SUP}}} \quad (\text{Expressed in dBc}) \quad (8)$$

Common Mode Rejection Ratio (CMRR)

CMRR is the measure of rejection of variations in the input common-mode voltage of the ADC. If ΔV_{cm} is the change in the input common-mode voltage and ΔV_{OUT} is the resultant change in the ADC output code (referred to the input), then

$$\text{CMRR} = 20\text{Log}^{10} \frac{\Delta V_{\text{OUT}}}{\Delta V_{\text{CM}}} \quad (\text{Expressed in dBc}) \quad (9)$$

Voltage Overload Recovery

The number of clock cycles taken to recover to less than 1% error for a 6-dB overload on the analog inputs. A 6-dBFS sine wave at Nyquist frequency is used as the test stimulus.

PACKAGING INFORMATION

Orderable Device	Status (1)	Package Type	Package Drawing	Pins	Package Qty	Eco Plan (2)	Lead/Ball Finish (6)	MSL Peak Temp (3)	Op Temp (°C)	Device Marking (4/5)	Samples
ADS5517IRGZR	ACTIVE	VQFN	RGZ	48	2500	Green (RoHS & no Sb/Br)	CU NIPDAU	Level-3-260C-168 HR	-40 to 85	AZ5517	Samples
ADS5517IRGZT	ACTIVE	VQFN	RGZ	48	250	Green (RoHS & no Sb/Br)	CU NIPDAU	Level-3-260C-168 HR	-40 to 85	AZ5517	Samples

(1) The marketing status values are defined as follows:

ACTIVE: Product device recommended for new designs.

LIFEBUY: TI has announced that the device will be discontinued, and a lifetime-buy period is in effect.

NRND: Not recommended for new designs. Device is in production to support existing customers, but TI does not recommend using this part in a new design.

PREVIEW: Device has been announced but is not in production. Samples may or may not be available.

OBSELETE: TI has discontinued the production of the device.

(2) Eco Plan - The planned eco-friendly classification: Pb-Free (RoHS), Pb-Free (RoHS Exempt), or Green (RoHS & no Sb/Br) - please check <http://www.ti.com/productcontent> for the latest availability information and additional product content details.

TBD: The Pb-Free/Green conversion plan has not been defined.

Pb-Free (RoHS): TI's terms "Lead-Free" or "Pb-Free" mean semiconductor products that are compatible with the current RoHS requirements for all 6 substances, including the requirement that lead not exceed 0.1% by weight in homogeneous materials. Where designed to be soldered at high temperatures, TI Pb-Free products are suitable for use in specified lead-free processes.

Pb-Free (RoHS Exempt): This component has a RoHS exemption for either 1) lead-based flip-chip solder bumps used between the die and package, or 2) lead-based die adhesive used between the die and leadframe. The component is otherwise considered Pb-Free (RoHS compatible) as defined above.

Green (RoHS & no Sb/Br): TI defines "Green" to mean Pb-Free (RoHS compatible), and free of Bromine (Br) and Antimony (Sb) based flame retardants (Br or Sb do not exceed 0.1% by weight in homogeneous material)

(3) MSL, Peak Temp. - The Moisture Sensitivity Level rating according to the JEDEC industry standard classifications, and peak solder temperature.

(4) There may be additional marking, which relates to the logo, the lot trace code information, or the environmental category on the device.

(5) Multiple Device Markings will be inside parentheses. Only one Device Marking contained in parentheses and separated by a "~" will appear on a device. If a line is indented then it is a continuation of the previous line and the two combined represent the entire Device Marking for that device.

(6) Lead/Ball Finish - Orderable Devices may have multiple material finish options. Finish options are separated by a vertical ruled line. Lead/Ball Finish values may wrap to two lines if the finish value exceeds the maximum column width.

Important Information and Disclaimer: The information provided on this page represents TI's knowledge and belief as of the date that it is provided. TI bases its knowledge and belief on information provided by third parties, and makes no representation or warranty as to the accuracy of such information. Efforts are underway to better integrate information from third parties. TI has taken and continues to take reasonable steps to provide representative and accurate information but may not have conducted destructive testing or chemical analysis on incoming materials and chemicals. TI and TI suppliers consider certain information to be proprietary, and thus CAS numbers and other limited information may not be available for release.

In no event shall TI's liability arising out of such information exceed the total purchase price of the TI part(s) at issue in this document sold by TI to Customer on an annual basis.

TAPE AND REEL INFORMATION



QUADRANT ASSIGNMENTS FOR PIN 1 ORIENTATION IN TAPE



*All dimensions are nominal

Device	Package Type	Package Drawing	Pins	SPQ	Reel Diameter (mm)	Reel Width W1 (mm)	A0 (mm)	B0 (mm)	K0 (mm)	P1 (mm)	W (mm)	Pin1 Quadrant
ADS5517IRGZR	VQFN	RGZ	48	2500	330.0	16.4	7.3	7.3	1.5	12.0	16.0	Q2
ADS5517IRGZT	VQFN	RGZ	48	250	180.0	16.4	7.3	7.3	1.5	12.0	16.0	Q2

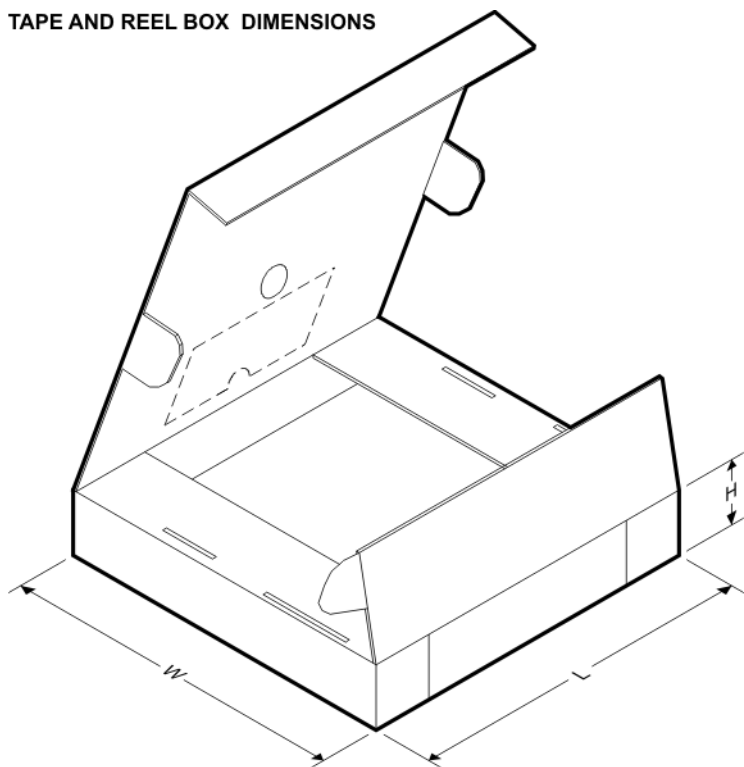
TAPE AND REEL BOX DIMENSIONS

*All dimensions are nominal

Device	Package Type	Package Drawing	Pins	SPQ	Length (mm)	Width (mm)	Height (mm)
ADS5517IRGZR	VQFN	RGZ	48	2500	350.0	350.0	43.0
ADS5517IRGZT	VQFN	RGZ	48	250	213.0	191.0	55.0

GENERIC PACKAGE VIEW

RGZ 48

VQFN - 1 mm max height

7 x 7, 0.5 mm pitch

PLASTIC QUADFLAT PACK- NO LEAD

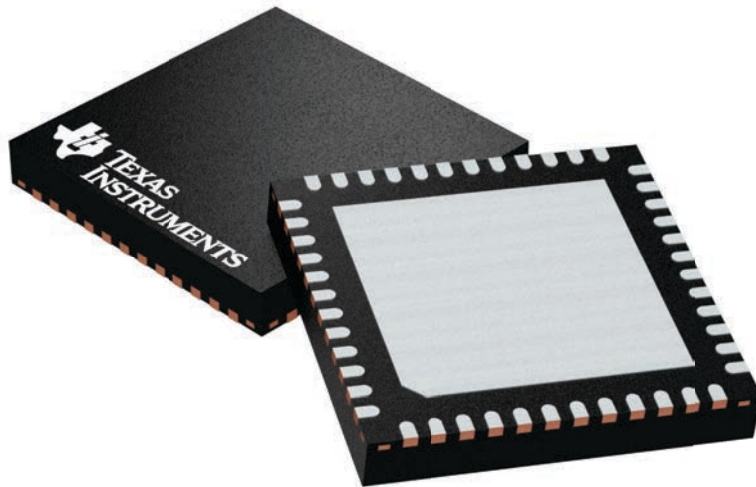

Images above are just a representation of the package family, actual package may vary.
Refer to the product data sheet for package details.

4224671/A

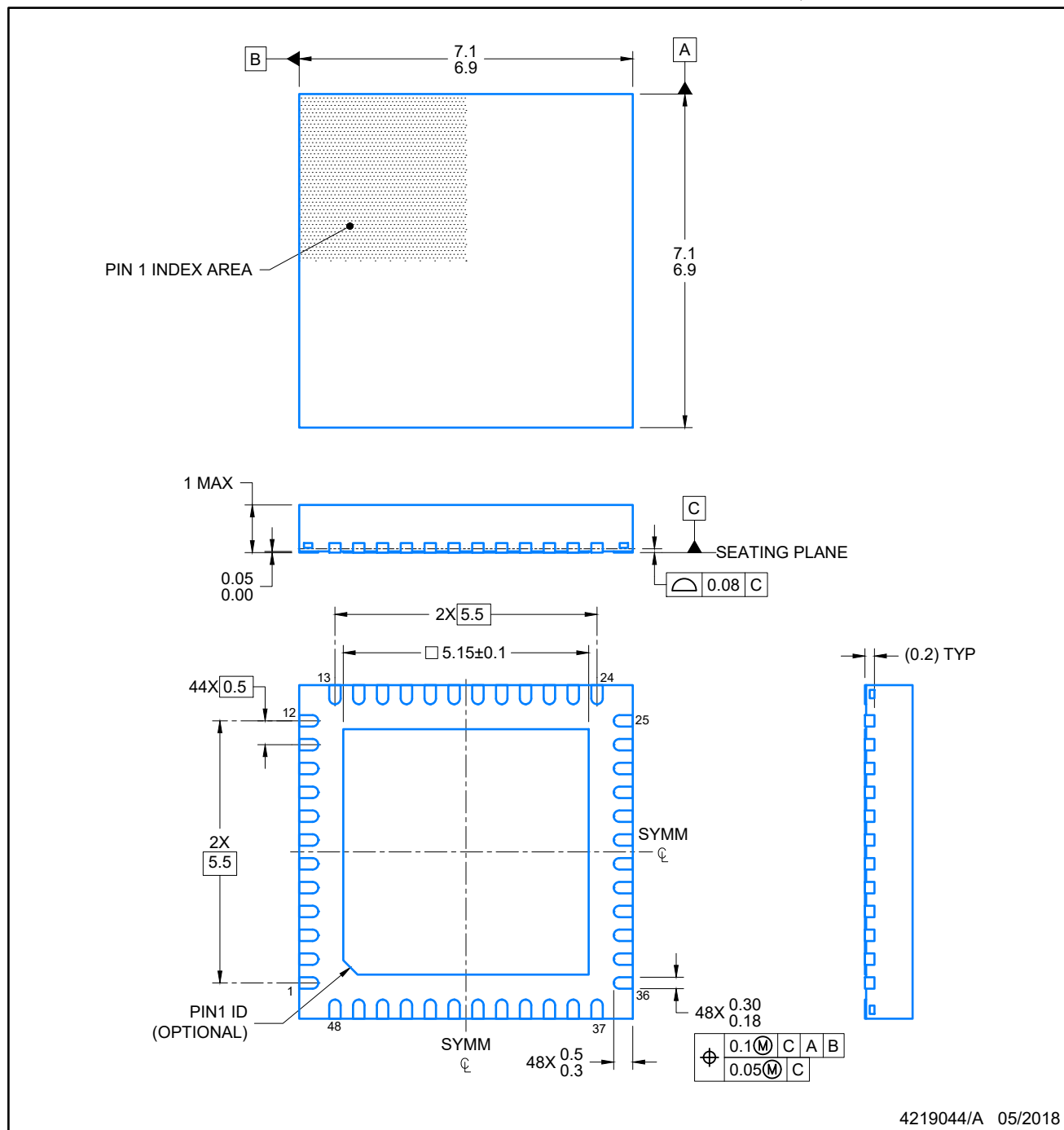

NOTES:

1. All linear dimensions are in millimeters. Any dimensions in parenthesis are for reference only. Dimensioning and tolerancing per ASME Y14.5M.
2. This drawing is subject to change without notice.
3. The package thermal pad must be soldered to the printed circuit board for optimal thermal and mechanical performance.

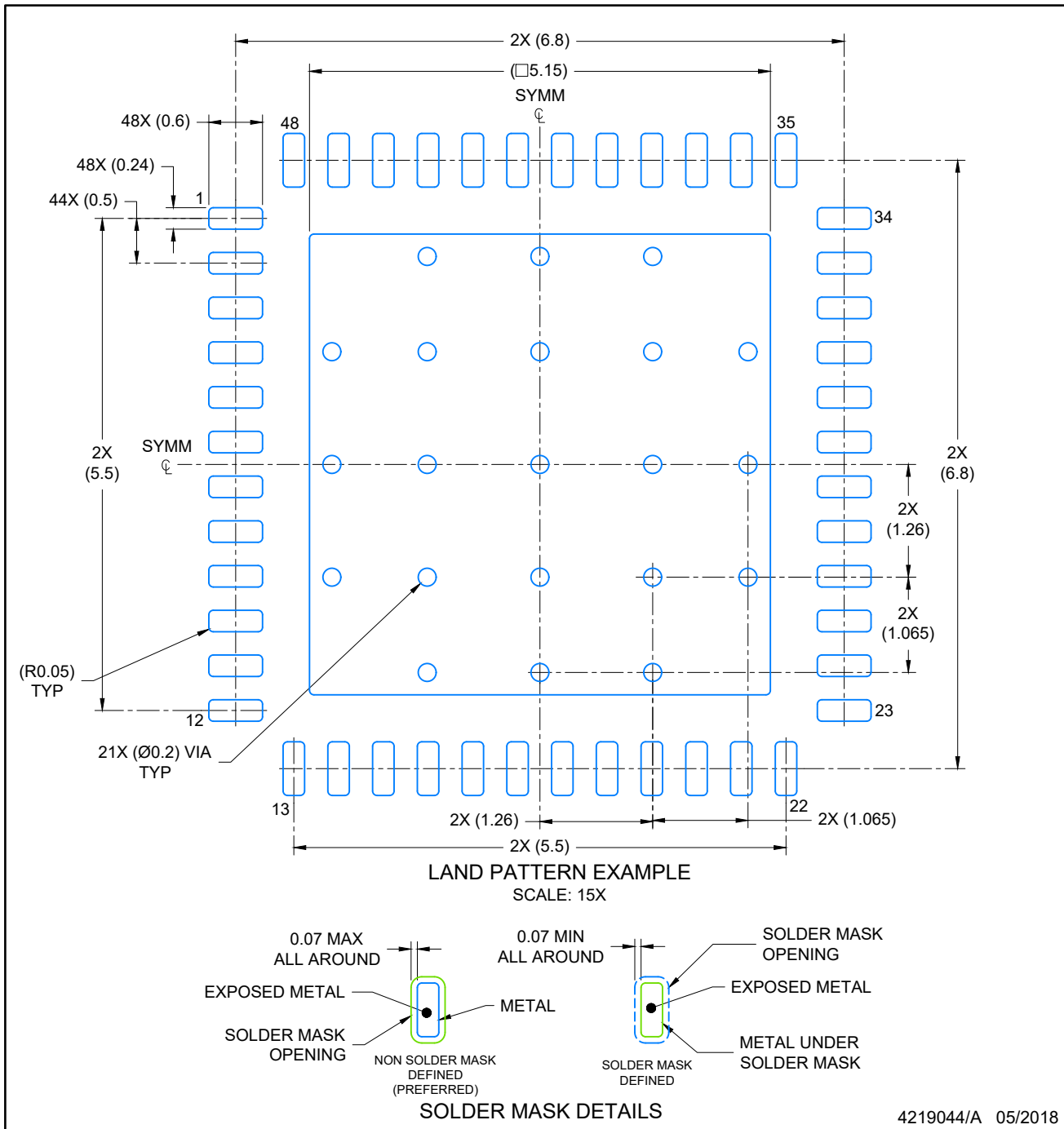

NOTES: (continued)

4. This package is designed to be soldered to a thermal pad on the board. For more information, see Texas Instruments literature number SLUA271 (www.ti.com/lit/sluea271).
5. Vias are optional depending on application, refer to device data sheet. If any vias are implemented, refer to their locations shown on this view. It is recommended that vias under paste be filled, plugged or tented.

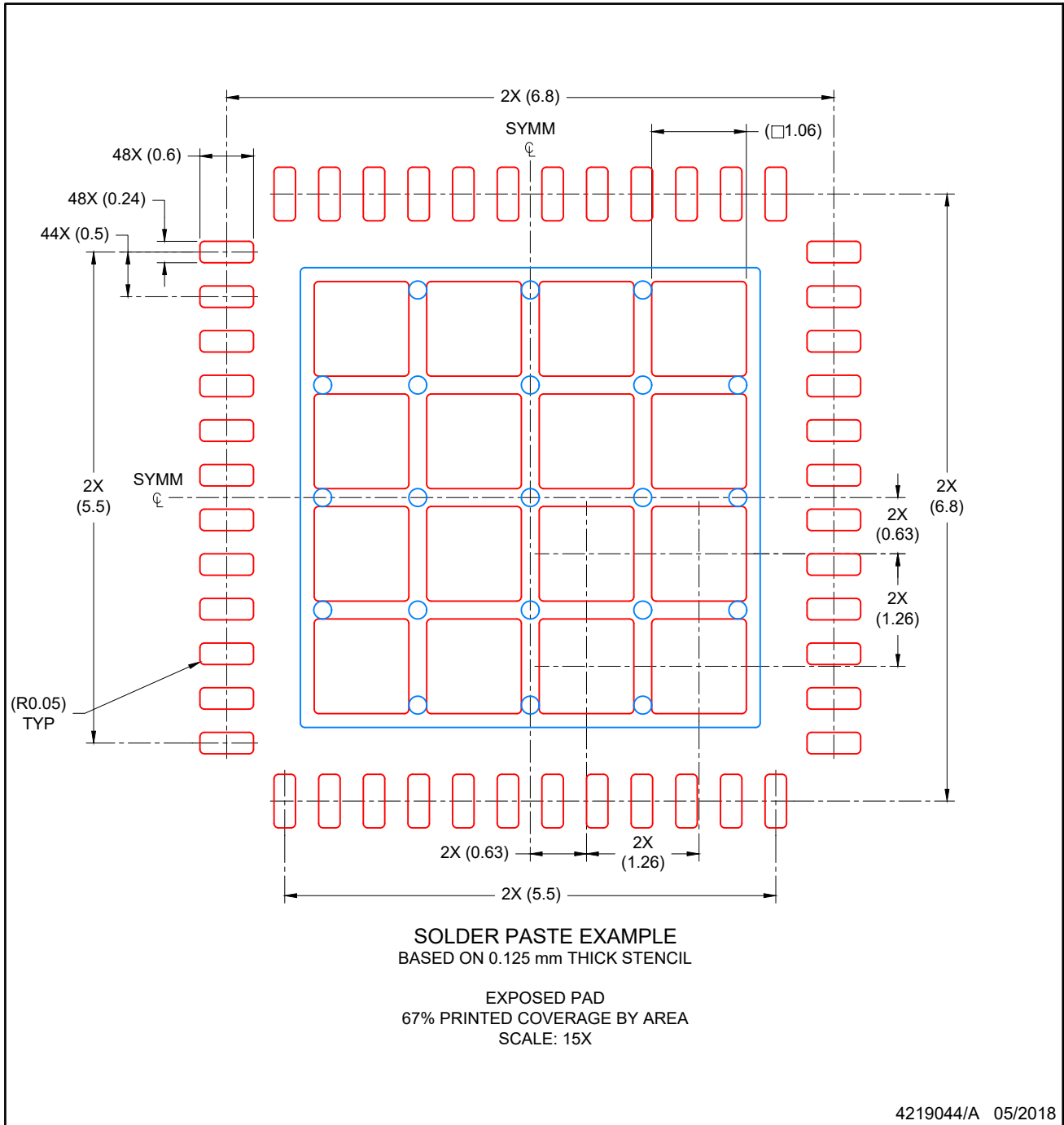

NOTES: (continued)

6. Laser cutting apertures with trapezoidal walls and rounded corners may offer better paste release. IPC-7525 may have alternate design recommendations.

IMPORTANT NOTICE AND DISCLAIMER

TI PROVIDES TECHNICAL AND RELIABILITY DATA (INCLUDING DATASHEETS), DESIGN RESOURCES (INCLUDING REFERENCE DESIGNS), APPLICATION OR OTHER DESIGN ADVICE, WEB TOOLS, SAFETY INFORMATION, AND OTHER RESOURCES "AS IS" AND WITH ALL FAULTS, AND DISCLAIMS ALL WARRANTIES, EXPRESS AND IMPLIED, INCLUDING WITHOUT LIMITATION ANY IMPLIED WARRANTIES OF MERCHANTABILITY, FITNESS FOR A PARTICULAR PURPOSE OR NON-INFRINGEMENT OF THIRD PARTY INTELLECTUAL PROPERTY RIGHTS.

These resources are intended for skilled developers designing with TI products. You are solely responsible for (1) selecting the appropriate TI products for your application, (2) designing, validating and testing your application, and (3) ensuring your application meets applicable standards, and any other safety, security, or other requirements. These resources are subject to change without notice. TI grants you permission to use these resources only for development of an application that uses the TI products described in the resource. Other reproduction and display of these resources is prohibited. No license is granted to any other TI intellectual property right or to any third party intellectual property right. TI disclaims responsibility for, and you will fully indemnify TI and its representatives against, any claims, damages, costs, losses, and liabilities arising out of your use of these resources.

TI's products are provided subject to TI's Terms of Sale (www.ti.com/legal/termsofsale.html) or other applicable terms available either on ti.com or provided in conjunction with such TI products. TI's provision of these resources does not expand or otherwise alter TI's applicable warranties or warranty disclaimers for TI products.

Mailing Address: Texas Instruments, Post Office Box 655303, Dallas, Texas 75265
Copyright © 2019, Texas Instruments Incorporated

Looking for pricing, stock, or lifecycle information?

Click below to explore more details on WIN SOURCE:

 [View ADS5517IRGZT](#) on WIN SOURCE

 [Texas Instruments](#) Information

Optimize Your Supply Chain with WIN SOURCE Solutions

-  Global Sourcing Solution
-  Obsolete Management
-  Cost Control Management
-  Shortage Management
-  Alternative Solution
-  Excess Inventory Management