



**THE DATASHEET OF
ADS62C15IRGCT**



Dual Channel 11-Bits, 125 MSPS ADC With Parallel CMOS/DDR LVDS Outputs

Check for Samples: [ADS62C15](#)

FEATURES

- **Maximum Sample Rate: 125 MSPS**
- **11-Bit Resolution With No Missing Codes**
- **82 dBc SFDR at $F_{in} = 117$ MHz**
- **67 dBFS SNR at $F_{in} = 117$ MHz**
- **77.5 dBFS SNR at $F_{in} = 117$ MHz, 20MHz bandwidth using *SNRBoost* technology**
- **92 dB Crosstalk**
- **Parallel CMOS and DDR LVDS Output Options**
- **3.5 dB Coarse Gain and Programmable Fine Gain up to 6 dB for SNR/SFDR Trade-Off**
- **Digital Processing Block With:**
 - **Offset Correction**
 - **Fine Gain Correction, in Steps of 0.05 dB**
 - **Decimation by 2/4/8**
 - **Built-in and Custom Programmable 24-Tap Low/High /Band Pass Filters**
- **Supports Sine, LVPECL, LVDS and LVCMOS Clocks and Amplitude Down to 400 mV_{pp}**
- **Clock Duty Cycle Stabilizer**
- **Internal Reference; Also Supports External Reference**
- **64-QFN Package (9mm × 9mm)**

APPLICATIONS

- **Wireless Communications Infrastructure**
- **Software Defined Radio**
- **Power Amplifier Linearization**
- **802.16d/e**
- **Medical Imaging**
- **Radar Systems**
- **Test and Measurement Instrumentation**

DESCRIPTION

ADS62C15 is a dual channel 11-bit A/D converter with maximum sample rates up to 125 MSPS. It combines high performance and low power consumption in a compact 64 QFN package. Using an internal sample and hold and low jitter clock buffer, the ADC supports high SNR and high SFDR at high input frequencies. It has coarse and fine gain options that can be used to improve SFDR performance at lower full-scale input ranges.

ADS62C15 uses proprietary *SNRBoost* technology that can be used to overcome SNR limitation due to quantization noise (for bandwidths less than Nyquist, $F_s/2$). It includes a digital processing block that consists of several useful and commonly used digital functions such as ADC offset correction, fine gain correction (in steps of 0.05 dB), decimation by 2,4,8 and in-built and custom programmable filters. By default, the digital processing block is bypassed, and its functions are disabled.

Two output interface options exist – parallel CMOS and DDR LVDS (Double Data Rate). ADS62C15 includes internal references while traditional reference pins and associated decoupling capacitors have been eliminated. The device can also be driven with an external reference. The device is specified over the industrial temperature range (–40°C to 85°C).



Please be aware that an important notice concerning availability, standard warranty, and use in critical applications of Texas Instruments semiconductor products and disclaimers thereto appears at the end of this data sheet.



This integrated circuit can be damaged by ESD. Texas Instruments recommends that all integrated circuits be handled with appropriate precautions. Failure to observe proper handling and installation procedures can cause damage.

ESD damage can range from subtle performance degradation to complete device failure. Precision integrated circuits may be more susceptible to damage because very small parametric changes could cause the device not to meet its published specifications.

FUNCTIONAL BLOCK DIAGRAM

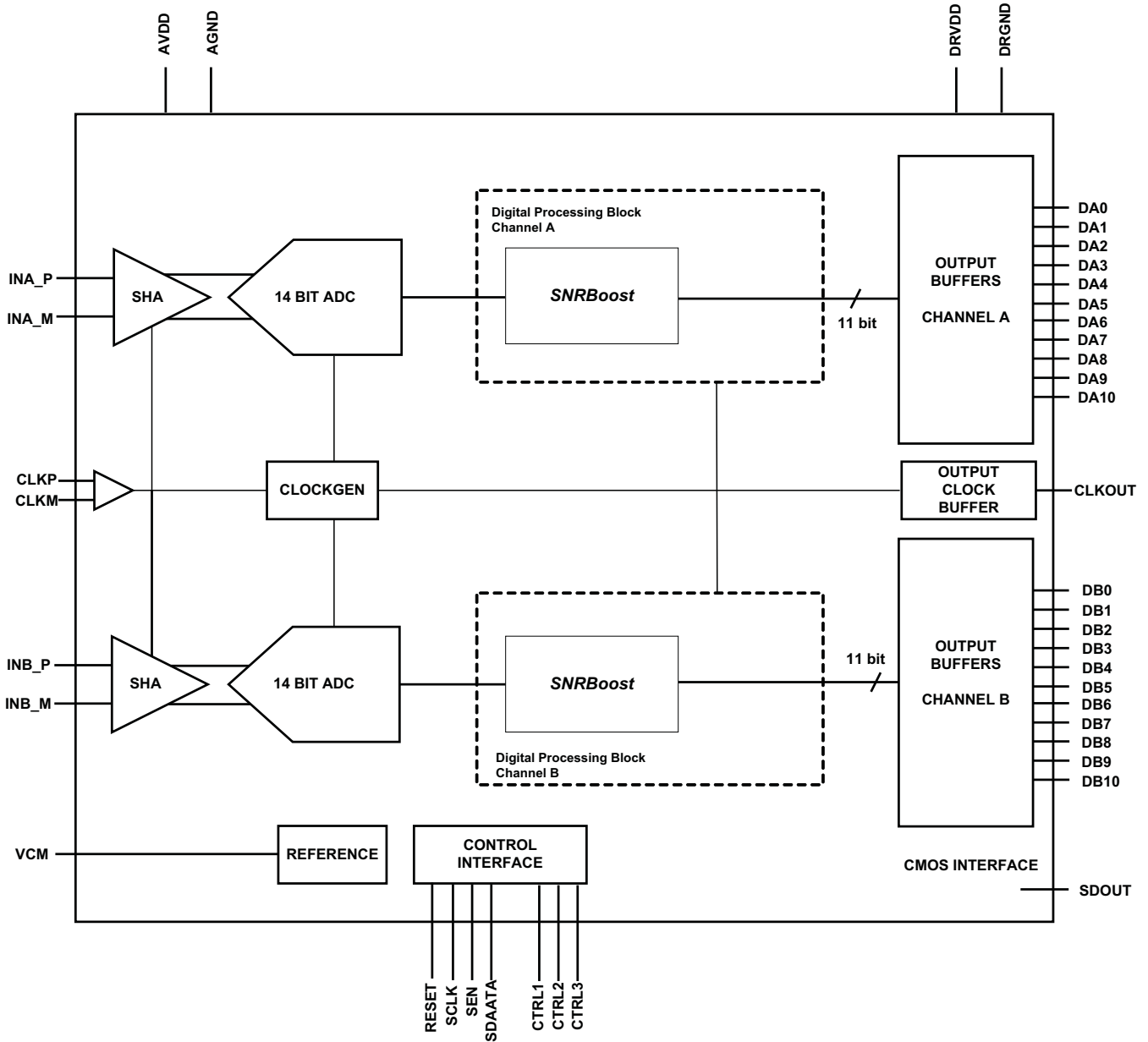

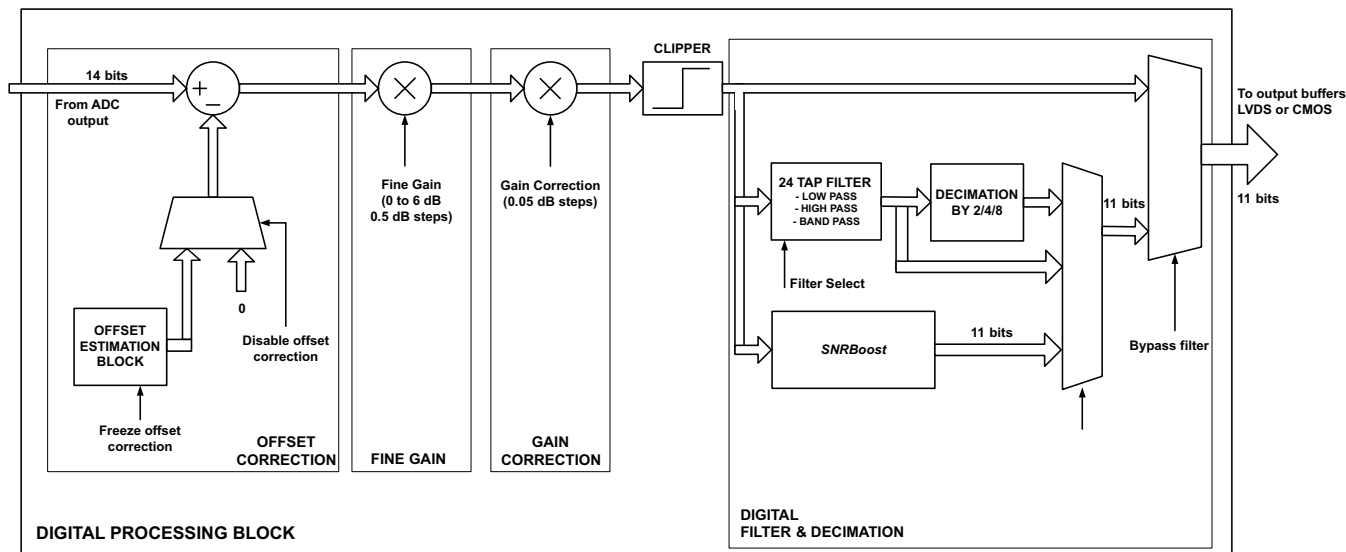

Figure 1. Digital Processing Block Diagram

PACKAGE/ORDERING INFORMATION⁽¹⁾

PRODUCT	PACKAGE-LEAD	PACKAGE DESIGNATOR	SPECIFIED TEMPERATURE RANGE	LEAD/BALL FINISH	PACKAGE MARKING	ORDERING ⁽²⁾ NUMBER	TRANSPORT MEDIA, QUANTITY
ADS62C15	QFN-64	RGC	-40°C to 85°C	Cu NiPdAu	AZ62C15	ADS62C15IRGCT	Tape and reel, 250
						ADS62C15IRGCR	Tape and reel, 2000

- (1) For thermal pad size on the package, see the mechanical drawings at the end of this data sheet. $\theta_{JA} = 23.17 \text{ }^\circ\text{C/W}$ (0 LFM airflow), $\theta_{JC} = 22.1 \text{ }^\circ\text{C/W}$ when used with 2 oz. copper trace and pad soldered directly to a JEDEC standard four layer 3 in. x 3 in. PCB.
 (2) For the most current package and ordering information, see the Package Option Addendum at the end of this document, or see the TI website at www.ti.com.

ABSOLUTE MAXIMUM RATINGS⁽¹⁾

		VALUE	UNIT
V_{SS}	Supply voltage range, AVDD, DRVDD	-0.3 V to 3.9	V
		-0.3 V to 3.9	V
	Voltage between AGND and DRGND	-0.3 to 0.3	V
	Voltage between AVDD to DRVDD	-0.3 to 3.3	V
	Voltage applied to external pin, CM (in external reference mode)	-0.3 to 2	V
	Voltage applied to analog input pins, INA_P, INA_M, INB_P, INB_M	-0.3 V to minimum (3.6, AVDD + 0.3 V)	V
	Voltage applied to clock input pins, CLKP, CLKM	-0.3 V to AVDD + 0.3 V	V
T_A	Operating free-air temperature range	-40 to 85	°C
T_J	Operating junction temperature range	125	°C
T_{stg}	Storage temperature range	-65 to 150	°C

- (1) Stresses beyond those listed under *absolute maximum ratings* may cause permanent damage to the device. These are stress ratings only and functional operation of the device at these or any other conditions beyond those indicated under *recommended operating conditions* is not implied. Exposure to absolute maximum rated conditions for extended periods may affect device reliability.

RECOMMENDED OPERATING CONDITIONS

over operating free-air temperature range (unless otherwise noted)

		MIN	NOM	MAX	UNIT	
SUPPLIES						
V _{SS}	Analog supply voltage, AVDD	3	3.3	3.6	V	
	Digital supply voltage, DRVDD	CMOS interface	1.65	1.8 to 3.3	3.6	V
		LVDS interface	3.0	3.3	3.6	
ANALOG INPUTS						
Differential input voltage range		2			V _{PP}	
Input common-mode voltage		1.5 ± 0.1			V	
Voltage applied on CM in external reference mode		1.5 ± 0.05			V	
CLOCK INPUT						
F _s	Input clock sample rate	1		125	MSPS	
Input clock amplitude differential (V _{CLKP} –V _{CLKM})	Sine wave, ac-coupled	0.4	3		V _{PP}	
	LVPECL, ac-coupled		1.6			
	LVDS, ac-coupled		0.7		V	
	LVC MOS, single-ended, ac-coupled		3.3			
Input clock duty cycle		35%	50%	65%		
DIGITAL OUTPUTS						
Output buffer drive strength ⁽¹⁾	For C _{LOAD} ≤ 5 pF and DRVDD ≥ 2.2 V	Default strength				
	For C _{LOAD} ≥ 5 pF and DRVDD ≥ 2.2 V	Maximum strength				
	For DRVDD < 2.2 V	Maximum strength				
C _{LOAD}	Maximum external load capacitance from each output pin to DRGND	CMOS interface			5	
		LVDS interface, without internal termination			5	
		LVDS interface, with 100 Ω internal termination			10	
R _{LOAD}	Differential load resistance between the LVDS output pairs (LVDS mode)	100			Ω	
T _A	Operating free-air temperature	–40		85	°C	

(1) See the [Output buffer strength programmability](#) in application section

ELECTRICAL CHARACTERISTICS

Typical values at 25°C, min and max values are across the full temperature range $T_{MIN} = -40^{\circ}\text{C}$ to $T_{MAX} = 85^{\circ}\text{C}$, $AVDD = 3.3\text{ V}$, $DRVDD = 1.8\text{ V}$ to 3.3 V , sampling frequency = 125 MSPS, 50% clock duty cycle, -1 dBFS differential analog input, internal reference mode, *SNRBoost* disabled, applies to CMOS and LVDS interfaces (unless otherwise noted).

PARAMETER		TEST CONDITIONS	MIN	TYP	MAX	UNIT
Resolution					11	bits
ANALOG INPUTS						
Differential input voltage range				2		V_{PP}
Differential input resistance (at dc)		See Figure 32		> 1		$M\Omega$
Differential input capacitance		See Figure 33		7		pF
Analog input bandwidth				450		MHz
Analog input common mode current (per input pin)				125		μA
VCM common mode voltage output				1.5		V
VCM output current capability				4		mA
POWER SUPPLY						
I_{SS}	Analog supply current (AVDD)			216		mA
	Output buffer supply current (DRVDD) CMOS interface	DRVDD = 1.8 V, 2.5 MHz input signal no load capacitance ⁽¹⁾		17		
	Total power – CMOS interface			0.74		W
Total power – CMOS interface		DRVDD = 3.3 V, 50 MHz input signal 10 pF load capacitance			1.22 5	W
Total power – LVDS interface		DRVDD = 3.3 V		0.94		W
Global power down				30	60	mW
DC ACCURACY						
No missing codes				Specified		
DNL	Differential Non-Linearity		-0.8	± 0.4	0.8	LSB
INL	Integral Non-Linearity		-3.5	± 1	3.5	LSB
E_O	Offset Error		-10	± 3	10	mV
Offset error temperature coefficient				0.05		$\text{mV}/^{\circ}\text{C}$
There are two sources of gain error – internal reference inaccuracy and channel gain error						
E_{GREF}	Gain error due to internal reference inaccuracy alone		-1	± 0.25	1	%FS
E_{GCHAN}	Gain error of channel alone ⁽²⁾		-1	± 0.3	1	%FS
Channel gain error temperature coefficient				0.005		$\Delta\%/^{\circ}\text{C}$

(1) In CMOS mode, the DRVDD current scales with the sampling frequency and the load capacitance on output pins (see [Figure 29](#)).

(2) This is specified by design and characterization; it is not tested in production.

ELECTRICAL CHARACTERISTICS (continued)

Typical values at 25°C, min and max values are across the full temperature range $T_{MIN} = -40^{\circ}C$ to $T_{MAX} = 85^{\circ}C$, $AVDD = 3.3 V$, $DRVDD = 1.8 V$ to $3.3 V$, sampling frequency = 125 MSPS, 50% clock duty cycle, -1 dBFS differential analog input, internal reference mode, *SNRBoost* disabled, applies to CMOS and LVDS interfaces (unless otherwise noted).

PARAMETER		TEST CONDITIONS		MIN	TYP	MAX	UNIT
SNR	Signal to noise ratio	Fin = 10 MHz			67.2		dBFS
		Fin = 50 MHz		65.5	67.1		
		Fin = 170 MHz	0 dB gain		66.8		
			3.5 dB gain		66.4		
		Fin = 230 MHz	0 dB gain		66.6		
			3.5 dB gain		66.2		
SINAD	Signal to noise and distortion ratio	Fin = 10 MHz			67.1		dBFS
		Fin = 50 MHz		65	66.9		
		Fin = 170 MHz	0 dB gain		66.5		
			3.5 dB gain		66.2		
		Fin = 230 MHz	0 dB gain		66.3		
			3.5 dB gain		65.9		
ENOB	Effective number of bits	Fin = 50 MHz		10.5	10.8		LSB
SFDR	Spurious free dynamic range	Fin = 10 MHz			89		dBc
		Fin = 50 MHz		75	79		
		Fin = 170 MHz	0 dB gain		82		
			3.5 dB gain		84		
		Fin = 230 MHz	0 dB gain		78		
			3.5 dB gain		80		
THD	Total harmonic distortion	Fin = 10 MHz			87		dBc
		Fin = 50 MHz		72	77		
		Fin = 170 MHz	0 dB gain		79		
			3.5 dB gain		81		
		Fin = 230 MHz	0 dB gain		75		
			3.5 dB gain		77		
HD2	Second harmonic distortion	Fin = 10 MHz			95		dBc
		Fin = 50 MHz		75	93		
		Fin = 170 MHz	0 dB gain		85		
			3.5 dB gain		87		
		Fin = 230 MHz	0 dB gain		82		
			3.5 dB gain		84		
HD3	Third harmonic distortion	Fin = 10 MHz			89		dBc
		Fin = 50 MHz		75	79		
		Fin = 170 MHz	0 dB gain		82		
			3.5 dB gain		84		
		Fin = 230 MHz	0 dB gain		78		
			3.5 dB gain		80		
Worst Spur	Other than second, third harmonics	Fin = 10 MHz			94		dBc
		Fin = 50 MHz			92		
		Fin = 170 MHz			90		
		Fin = 230 MHz			88		
IMD	2-Tone intermodulation distortion	F1 = 185 MHz, F2 = 190 MHz each tone at -7 dBFS			88		dBFS
	Input overload recovery	Recovery to within 1% (of final value) for 6-dB overload with sine wave input			1		clock cycles

ELECTRICAL CHARACTERISTICS (continued)

Typical values at 25°C, min and max values are across the full temperature range $T_{MIN} = -40^{\circ}\text{C}$ to $T_{MAX} = 85^{\circ}\text{C}$, $AVDD = 3.3\text{ V}$, $DRVDD = 1.8\text{ V}$ to 3.3 V , sampling frequency = 125 MSPS, 50% clock duty cycle, -1 dBFS differential analog input, internal reference mode, *SNRBoost* disabled, applies to CMOS and LVDS interfaces (unless otherwise noted).

PARAMETER		TEST CONDITIONS	MIN	TYP	MAX	UNIT
Cross-talk		Cross-talk signal frequency up to 100 MHz		95		dB
PSRR	AC Power supply rejection ratio	For 100 mV _{PP} signal on AVDD supply, frequency up to 10 MHz		45		dBc

Table 1. SNR Improvement with *SNRBoost* Sampling Frequency at 125 MSPS ⁽¹⁾ ⁽²⁾

INPUT FREQUENCY MHz	BANDWIDTH MHz	SNR, SIGNAL TO NOISE RATIO (TYP) dBFS			
		SNRBoost disabled, dB		SNRBoost enabled, dB	
		MIN	TYP	MIN	TYP
117	5	77	78.1	81	85.1
	10	74	75.1	78	82
	15	72	73.3	76	79.6
	20	71	72.1	74.5	77.5

(1) The min SNR value with *SNRBoost* enabled is specified by design and characterization; it is not tested in production.

(2) This table shows the SNR improvement over some selected bandwidths. With *SNRBoost*, SNR improvement can be achieved for any bandwidth less than (Sampling frequency/2). As the bandwidths increase, the amount of improvement reduces.

DIGITAL CHARACTERISTICS

The DC specifications refer to the condition where the digital outputs are not switching, but are permanently at a valid logic level 0 or 1. $AVDD = 3.3\text{ V}$, $DRVDD = 1.8\text{ V}$ to 3.3 V , unless otherwise specified.

PARAMETER		TEST CONDITIONS	MIN	TYP	MAX	UNIT
DIGITAL INPUTS						
High-level input voltage			2.4			V
Low-level input voltage					0.8	V
High-level input current				33		μA
Low-level input current				-33		μA
Input capacitance				4		Pf
DIGITAL OUTPUTS – CMOS MODE, $DRVDD = 1.8$ to 3.3 V						
High-level output voltage				DRVDD		V
Low-level output voltage				0		V
Output capacitance (internal to device)				2		pF
DIGITAL OUTPUTS – LVDS MODE ⁽¹⁾ ⁽²⁾, $DRVDD = 3.3\text{ V}$						
High-level output voltage				1375		mV
Low-level output voltage				1025		mV
$ V_{OD} $	Output differential voltage		250	350	500	mV
V_{OS}	Output offset voltage	Common-mode voltage of OOTP and OUTM		1200		mV
Output Capacitance		Output capacitance inside the device, from either output to ground		2		pF

(1) LVDS buffer current setting, $I_O = 3.5\text{ mA}$.

(2) External differential load resistance between the LVDS output pairs, $R_{LOAD} = 100\ \Omega$.

TIMING REQUIREMENTS – LVDS AND CMOS MODES⁽¹⁾

Typical values are at 25°C, min and max values are across the full temperature range $T_{MIN} = -40^{\circ}C$ to $T_{MAX} = 85^{\circ}C$, $AVDD = 3.3 V$, $DRVDD = 1.8 V$ to $3.3 V$, sampling frequency = 125 MSPS, sine wave input clock, 3 V_{PP} clock amplitude, $C_{LOAD} = 5 pF$ ⁽²⁾, $I_O = 3.5 mA$, $R_{LOAD} = 100 \Omega$ ⁽³⁾, no internal termination, unless otherwise noted.

PARAMETER	TEST CONDITIONS		MIN	TYP	MAX	UNIT
t_a Aperture delay			0.8	1.8	2.8	ns
t_j Aperture jitter			130			fs rms
Wake-up time to valid output data	from global power down		15	50	μs	
	from channel standby		100	200	ns	
	from output buffer disable	CMOS	100	200	ns	
		LVDS	200	500	ns	
Latency	default, after reset		14			clock cycles
	in low latency mode		10			clock cycles
	with decimation filter enabled		15			clock cycles
DDR LVDS MODE⁽⁴⁾ DRVDD = 3.3 V						
t_{su} Data setup time ⁽⁵⁾	Data valid ⁽⁶⁾ to zero-crossing of CLKOUTP		0.6	1.5	ns	
t_h Data hold time ⁽⁵⁾	Zero-crossing of CLKOUTP to data becoming invalid ⁽⁶⁾		1.0	2.3	ns	
t_{PDI} Clock propagation delay	Input clock rising edge cross-over to output clock rising edge cross-over <i>20 MSPS ≤ Sampling frequency ≤ 125 MSPS</i>		3.5	5.5	7.5	ns
LVDS bit clock duty cycle	Duty cycle of differential clock, (CLKOUTP-CLKOUTM) <i>10 MSPS ≤ Sampling frequency ≤ 125 MSPS</i>		46%	49%	52%	
t_{RISE} Data rise time	Rise time measured from -100 mV to 100 mV <i>1 MSPS ≤ Sampling frequency ≤ 125 MSPS</i>		70	110	170	ps
t_{FALL} Data fall time	Fall time measured from 100 mV to -100 mV <i>1 MSPS ≤ Sampling frequency ≤ 125 MSPS</i>		70	110	170	ps
$t_{CLKRISE}$ Output clock rise time	Rise time measured from -100 mV to 100 mV <i>1 MSPS ≤ Sampling frequency ≤ 125 MSPS</i>		70	110	170	ps
$t_{CLKFALL}$ Output clock fall time	Fall time measured from 100 mV to -100 mV <i>1 MSPS ≤ Sampling frequency ≤ 125 MSPS</i>		70	110	170	ps
PARALLEL CMOS MODE DRVDD = 2.5 V to 3.3 V						
t_{su} Data setup time ⁽⁵⁾	Data valid ⁽⁷⁾ to 50% of CLKOUT rising edge		2.0	3.5	ns	
t_h Data hold time ⁽⁵⁾	50% of CLKOUT rising edge to data becoming invalid ⁽⁷⁾		2.0	3.5	ns	
t_{PDI} Clock propagation delay	50% of input clock rising edge to 50% of CLKOUT rising edge <i>20 MSPS ≤ Sampling frequency ≤ 125 MSPS</i>		5.8	7.3	8.8	ns
Output clock duty cycle	Duty cycle of output clock, CLKOUT <i>10 MSPS ≤ Sampling frequency ≤ 125 MSPS</i>		45%	53%	60%	
t_{RISE} Data rise time	Rise time measured from 20% to 80% of DRVDD <i>1 MSPS ≤ Sampling frequency ≤ 125 MSPS</i>		0.7	1.5	2.5	ns
t_{FALL} Data fall time	Fall time measured from 80% to 20% of DRVDD <i>1 MSPS ≤ Sampling frequency ≤ 125 MSPS</i>		0.7	1.5	2.5	ns
$t_{CLKRISE}$ Output clock rise time	Rise time measured from 20% to 80% of DRVDD <i>1 MSPS ≤ Sampling frequency ≤ 125 MSPS</i>		0.7	1.5	2.5	ns
$t_{CLKFALL}$ Output clock fall time	Fall time measured from 80% to 20% of DRVDD <i>1 MSPS ≤ Sampling frequency ≤ 125 MSPS</i>		0.7	1.5	2.5	ns

- (1) Timing parameters are ensured by design and characterization and not tested in production.
- (2) C_{LOAD} is the effective external single-ended load capacitance between each output pin and ground
- (3) I_O refers to the LVDS buffer current setting; R_{LOAD} is the differential load resistance between the LVDS output pair.
- (4) Measurements are done with a transmission line of 100Ω characteristic impedance between the device and the load.
- (5) Setup and hold time specifications take into account the effect of jitter on the output data and clock.
- (6) Data valid refers to LOGIC HIGH of 100 mV and LOGIC LOW of -100 mV.
- (7) Data valid refers to LOGIC HIGH of 2 V (1.7 V) and LOGIC LOW of 0.8 V (0.7 V) for $DRVDD = 3.3 V$ (2.5 V)

Table 2. Timing Characteristics at Lower Sampling Frequencies

Sampling Frequency, MSPS	t_{su} DATA SETUP TIME, ns			t_h DATA HOLD TIME, ns		
	MIN	TYP	MAX	MIN	TYP	MAX
CMOS INTERFACE, DRVDD = 2.5 TO 3.3 V						
105	2.8	4.3		2.7	4.2	
80	4.3	5.8		4.2	5.7	
65	5.7	7.2		5.6	7.1	
40	10.5	12		10.3	11.8	
20	23	24.5		23	24.5	
DDR LVDS INTERFACE, DRVDD = 3.3 V						
105	1	2.3		1.0	2.3	
80	2.4	3.8				
65	3.8	5.2				
40	8.5	10				
20	21	22.5				

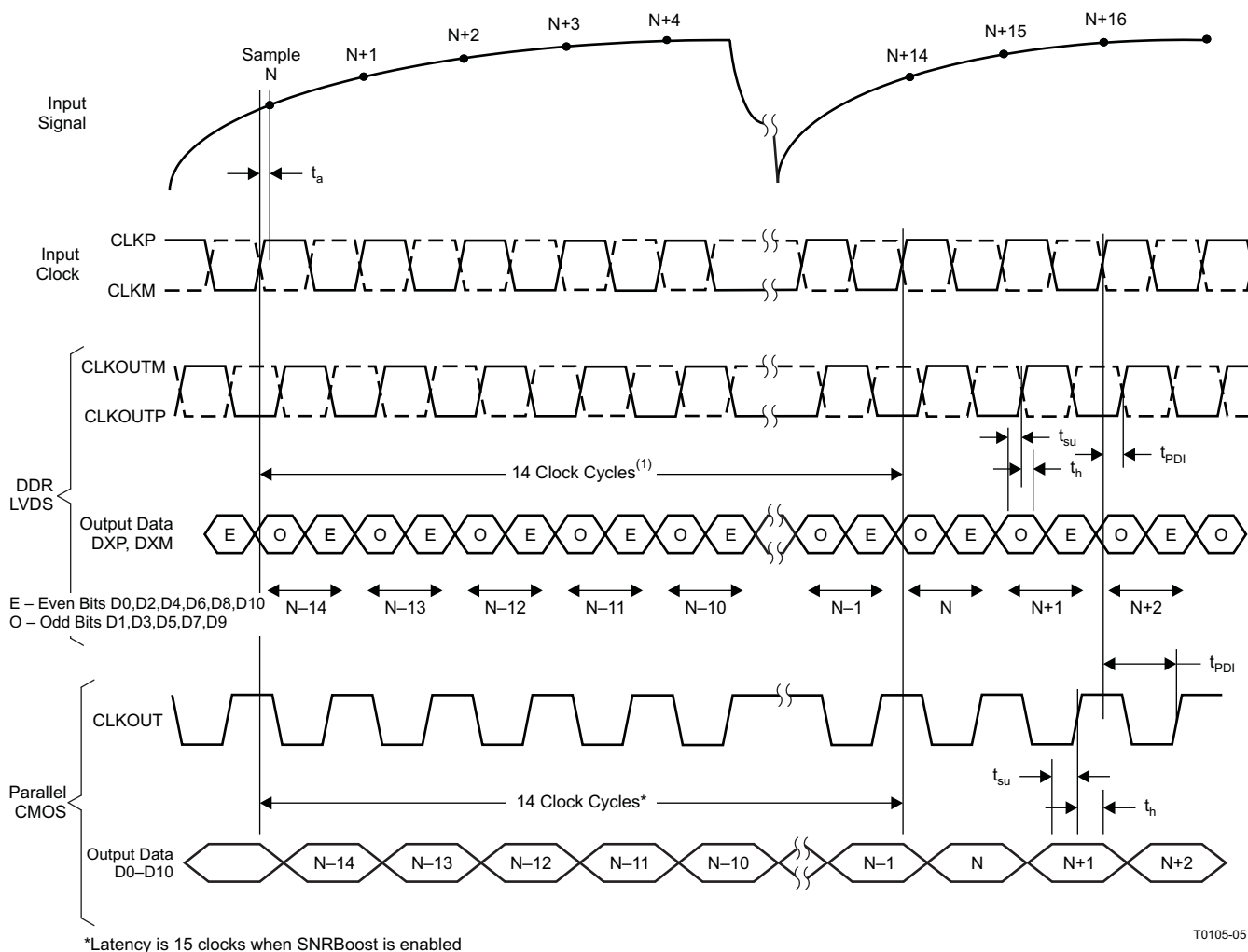

Figure 2. Latency Diagram

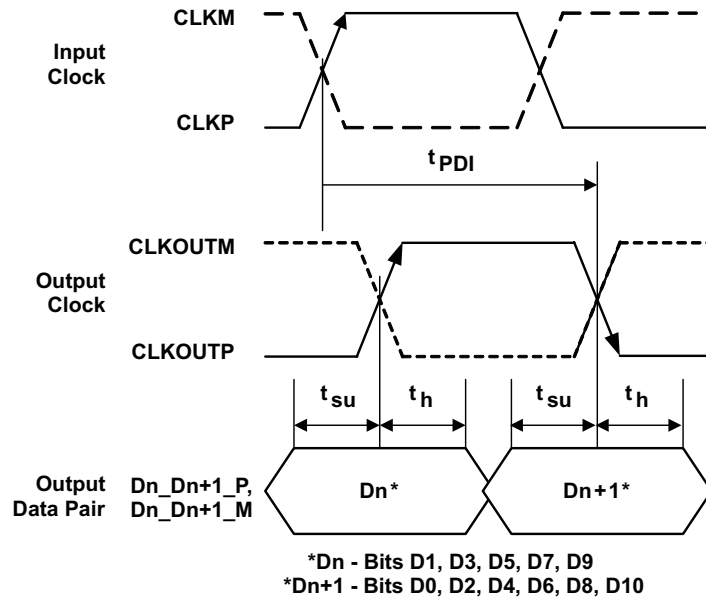
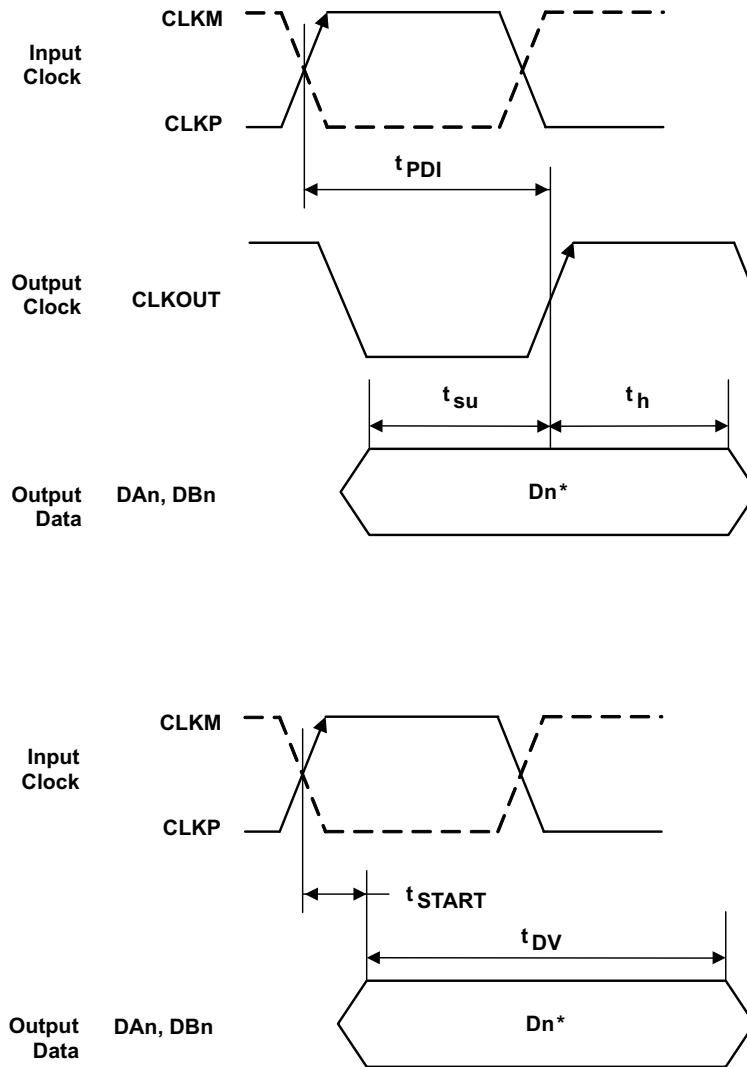

Figure 3. LVDS Mode Timing



* D_n - Bits D0, D1, D2, . . . of Channels A & B

Figure 4. CMOS Mode Timing

DEVICE CONFIGURATION

ADS62C15 can be configured independently using either parallel interface control or serial interface programming.

USING PARALLEL INTERFACE CONTROL ONLY

To control the device using the parallel interface, keep RESET tied to **high** (AVDD). Pins SEN, SCLK, CTRL1, CTRL2 and CTRL3 can be used to directly control certain modes of the ADC. After power-up, the device will automatically get configured as per the parallel pin voltage settings (Table 4 to Table 6).

In this mode, SEN and SCLK function as parallel *analog* control pins, which can be configured using a simple resistor divider (Figure 5). Table 3 has a brief description of the modes controlled by the parallel pins.

Table 3. Parallel Pin Definition

PIN	TYPE OF PIN	CONTROLS MODES
SCLK	Analog control pins (controlled by analog voltage levels, see)	Coarse Gain and Internal/External reference
SEN		LVDS/CMOS interface and Output Data Format
CTRL1	Digital control pins (controlled by digital logic levels)	Together control various power down modes and MUX mode.
CTRL2		
CTRL3		

USING SERIAL INTERFACE PROGRAMMING ONLY

To program the device using the serial interface, keep RESET low. Pins SEN, SDATA, and SCLK function as serial interface *digital* pins and are used to access the internal registers of ADC. The registers must first be reset to their default values either by applying a pulse on RESET pin or by setting bit <RST> = 1. After reset, the RESET pin must be kept low.

The serial interface section describes the register programming and register reset in more detail. Since the parallel pins (CTRL1, CTRL2, CTRL3) are not used in this mode, they must be tied to ground.

USING BOTH SERIAL INTERFACE and PARALLEL CONTROLS

For increased flexibility, a combination of serial interface registers and parallel pin controls (CTRL1 to CTRL3) can also be used to configure the device. To allow this, keep RESET **low**.

The parallel interface control pins CTRL1 to CTRL3 are available. After power-up, the device will automatically get configured as per the voltage settings on these pins (Table 6).

SEN, SDATA, and SCLK function as serial interface *digital* pins and are used to access the internal registers of ADC. The registers must first be reset to their default values either by applying a pulse on RESET pin or by setting bit <RST> = 1. After reset, the RESET pin must be kept low. The serial interface section describes the register programming and register reset in more detail.

Since the power down modes can be controlled using both the parallel pins and serial registers, the priority between the two is determined by <OVRD> bit. When <OVRD> bit = 0, pins CTRL1 to CTRL3 control the power down modes. With <OVRD> = 1, register bits <POWER DOWN> control these modes, over-riding the pin settings.

DETAILS OF PARALLEL CONFIGURATION ONLY

The functions controlled by each parallel pin are described below. A simple way of configuring the parallel pins is shown in [Figure 5](#).

Table 4. SCLK (Analog Control Pin)

SCLK	DESCRIPTION
0	0 dB gain and Internal reference
(3/8)AVDD	0 dB gain and External reference
(5/8)2AVDD	3.5 dB Coarse gain and External reference
AVDD	3.5 dB Coarse gain and Internal reference

Table 5. SEN (Analog Control Pin)

SEN	DESCRIPTION
0	2s complement format and DDR LVDS output
(3/8)AVDD	Straight binary and DDR LVDS output
(5/8)AVDD	Straight binary and parallel CMOS output
AVDD	2s complement format and parallel CMOS output

Table 6. CTRL1, CTRL2 and CTRL3 (Digital Control Pins)

CTRL1	CTRL2	CTRL3	DESCRIPTION
LOW	LOW	LOW	Normal operation
LOW	LOW	HIGH	Channel A output buffer disabled
LOW	HIGH	LOW	Channel B output buffer disabled
LOW	HIGH	HIGH	Channel A and B output buffer disabled
HIGH	LOW	LOW	Channel A and B powered down
HIGH	LOW	HIGH	Channel A standby
HIGH	HIGH	LOW	Channel B standby
HIGH	HIGH	HIGH	MUX mode of operation (only with CMOS interface Channel A and B data is multiplexed and output on DB10 to DB0 pins. See Multiplexed output mode for detailed description.

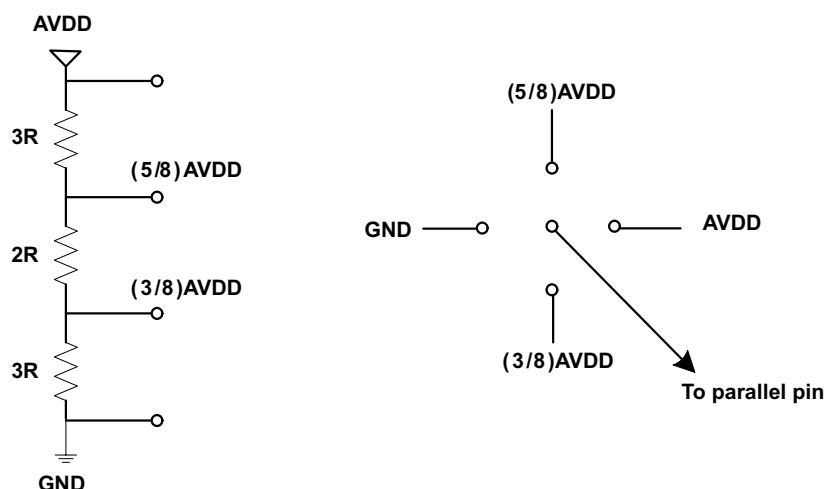

Figure 5. Simple Scheme to Configure Parallel Pins

SERIAL INTERFACE

The ADC has a set of internal registers, which can be accessed by the serial interface formed by pins SEN (Serial interface Enable), SCLK (Serial Interface Clock) and SDATA (Serial Interface Data).

Serial shift of bits into the device is enabled when SEN is low. Serial data SDATA is latched at every falling edge of SCLK when SEN is active (low). The serial data is loaded into the register at every 16th SCLK falling edge when SEN is low. If the word length exceeds a multiple of 16 bits, the excess bits are ignored. Data can be loaded in multiple of 16-bit words within a single active SEN pulse.

The first 8 bits form the register address and the remaining 8 bits the register data. The interface can work with SCLK frequency from 20 MHz down to low speeds (few Hertz), and also with a non-50% SCLK duty cycle.

Register Initialization

After power-up, the internal registers **must** be initialized to their default values. This is done in one of two ways:

1. Either through hardware reset by applying a high-going pulse on the RESET pin (of width greater than 10 ns) as shown in Figure 6.

OR

2. By applying software reset. Using the serial interface, set the <RST> bit to **high**. This initializes internal registers to their default values, and then self-resets the <RST> bit to **low**. In this case, the RESET pin is kept **low**.

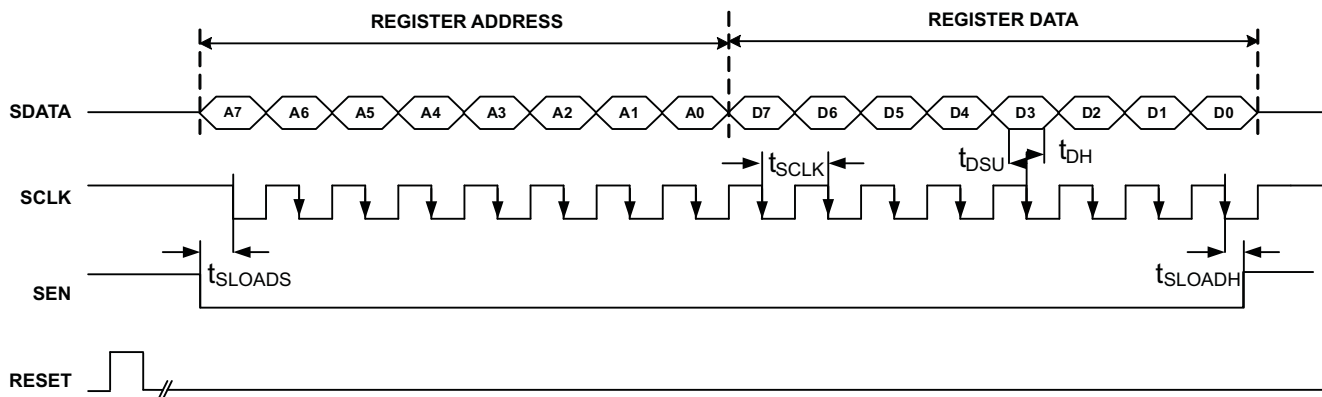

Figure 6. Serial Interface Timing

SERIAL INTERFACE TIMING CHARACTERISTICS

Typical values at 25°C, min and max values across the full temperature range $T_{MIN} = -40^{\circ}C$ to $T_{MAX} = 85^{\circ}C$, AVDD = 3.3 V, DRVDD = 1.8 V to 3.3 V, unless otherwise noted.

PARAMETER		MIN	TYP	MAX	UNIT
f_{SCLK}	SCLK frequency	> DC		20	MHz
t_{SLOADS}	SEN to SCLK setup time	25			ns
t_{SLOADH}	SCLK to SEN hold time	25			ns
t_{DS}	SDATA setup time	25			ns
t_{DH}	SDATA hold time	25			ns

Serial Register Readout (Only When CMOS Interface is Used)

The device includes an option where the contents of the internal registers can be read back. This may be useful as a diagnostic check to verify the serial interface communication between the external controller and the ADC.

- a. First, set register bit <SERIAL READOUT> = 1 to put the device in serial readout mode. This disables any further writes into the registers, EXCEPT the register at address 0. Note that the <SERIAL READOUT> bit is also located in register 0. The device can exit readout mode by writing <SERIAL READOUT> to 0. Also, only the contents of register at address 0 cannot be read in the register readout mode.
- b. Initiate a serial interface cycle specifying the address of the register (A7-A0) the content of which must be read.
- c. The device outputs the contents (D7-D0) of the selected register on the SDOUT pin.
- d. The external controller can latch the contents at the falling edge of SCLK.
- e. To exit the serial readout mode, reset register bit <SERIAL READOUT> =0, which enables writes into all registers of the device.

The serial register readout works only with CMOS interface; with LVDS interface, pin 56 functions as CLKOUTM.

When <SERIAL READOUT> is disabled, the SDOUT pin is forced low or high by the device (and not put in high-impedance). If serial readout is not used, the SDOUT pin must be floated.

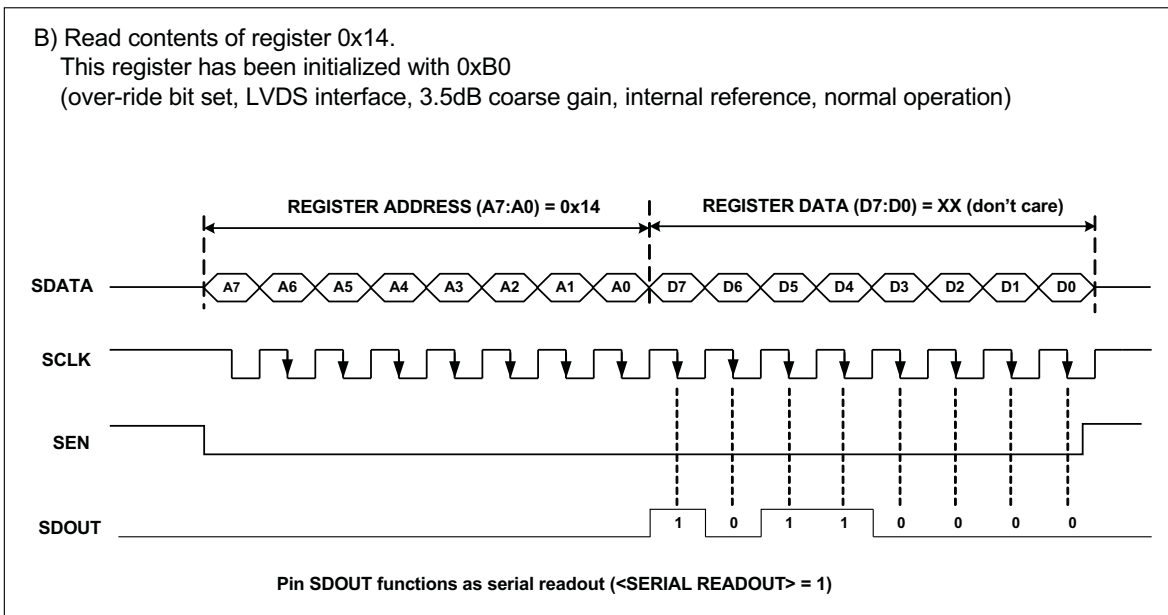
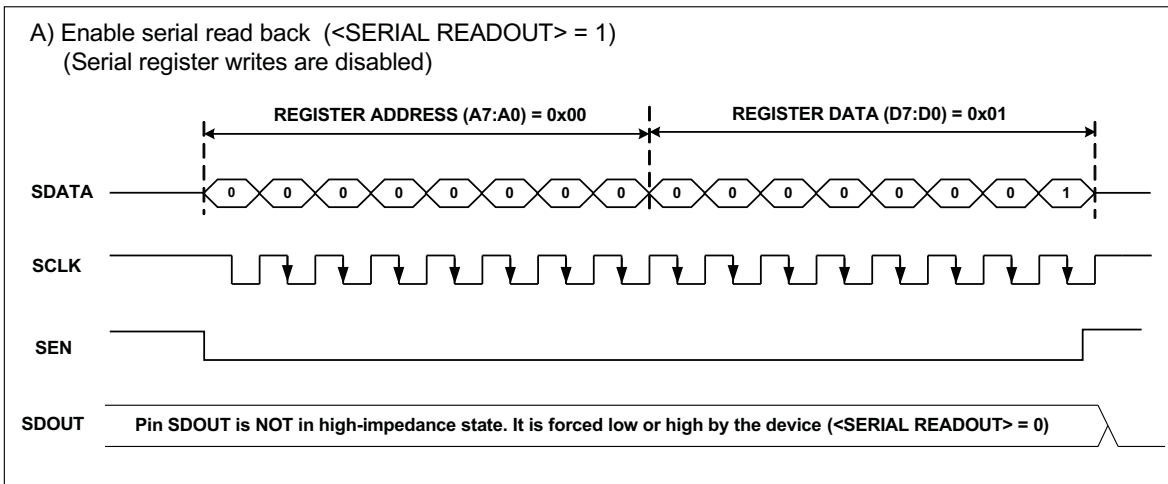
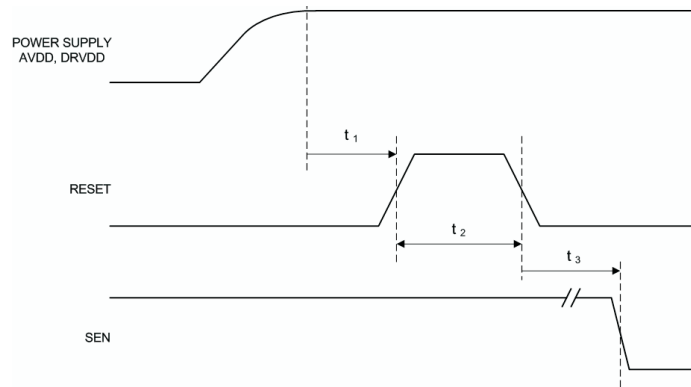

Figure 7. Serial Readout

RESET TIMING

Typical values at 25°C, min and max values across the full temperature range $T_{MIN} = -40^{\circ}C$ to $T_{MAX} = 85^{\circ}C$, unless otherwise noted.

PARAMETER	CONDITIONS	MIN	TYP	MAX	UNIT
t_1	Power-on delay	5			ms
t_2	Reset pulse width	10			ns
t_3	Register write delay	25			ns
t_{PO}	Power-up time		7		ms



NOTE: : A high-going pulse on RESET pin is required in serial interface mode in case of initialization through hardware reset. For parallel interface operation, RESET has to be tied permanently HIGH.

Figure 8. Reset Timing Diagram

SERIAL REGISTER MAP

Table 7. Summary of Functions Supported by Serial Interface ⁽¹⁾

REGISTER ADDRESS	REGISTER FUNCTIONS							
A7–A0 IN HEX	D7	D6	D5	D4	D3	D2	D1	D0
00	0	0	0	0	0	0	<RST> <i>Software Reset</i>	<SERIAL READOUT >
10	<CLKOUT STRENGTH>		0	0	0	0	0	0
11	0	0	<CURRENT DOUBLE> <i>LVDS buffer current double</i>		<LVDS CURRENT> <i>LVDS buffer current programmability</i>		<DATAOUT STRENGTH>	
12	0	0	<LVDS TERMINATION> <i>Internal termination programmability</i>					
13	0	0	0	<OFFSET FREEZE>	0	0	0	0
14	<OVRD> <i>Over-ride bit</i>	0	<OUTPUT INTERFACE> <i>LVDS or CMOS interface</i>	<COARSE GAIN> <i>3.5 dB gain</i>	<REF> <i>Internal/External reference</i>	<POWER DOWN MODES>		
16	0	0	0	<DATA FORMAT> <i>2s complement or straight binary</i>	Bit/Byte wise (LVDS only)		<TEST PATTERNS>	
17	0	0	0	0	<FINE GAIN> <i>0 to 6 dB gain in 0.5 dB steps</i>			
18	<CUSTOM LOW> <i>Lower 8 bits</i>					0	0	0
19	0	0	<CUSTOM HIGH> <i>Upper 6 bits</i>					
1A	<LOW LATENCY>	<OFFSET TC> <i>Offset correction time constant</i>			<GAIN CORRECTION> <i>0 to 0.5 dB, steps of 0.05 dB</i>			
1B	<OFFSET EN> <i>Other correction enable</i>	0	<FILTER COEFF SELECT> <i>In-built or custom coefficients</i>	<DECIMATION Enable> <i>Enable decimation</i>	<ODD TAP Enable>	<DECIMATION RATE> <i>Decimate by 2, 4, 8</i>		
1C	<SNRBoost Coeff1>				<SNRBoost Coeff2>			
1D	0	0	0	0	0	0	<DECIMATION FILTER FREQ BANDS>	
1E to 2F	<FILTER COEFFICIENTS> <i>12 coefficients, each 12 bit signed</i>							

(1) Multiple functions in a register can be programmed in a single write operation.

DESCRIPTION OF SERIAL REGISTERS
Table 8.

A7–A0 (hex)	D7	D6	D5	D4	D3	D2	D1	D0
00	0	0	0	0	0	0	<RST> Software Reset	<SERIAL READOUT>

D1 <RST>

1 Software reset applied – resets all internal registers and self-clears to 0.

D0 <SERIAL READOUT>

0 Serial readout disabled. SDOUT pin is forced low or high by the device (and not put in high-impedance state)

1 Serial readout enabled, SDOUT functions as serial data readout pin.

Table 9.

A7–A0 (hex)	D7	D6	D5	D4	D3	D2	D1	D0
10	<CLKOUT STRENGTH>		0	0	0	0	0	0

D7–D6 <CLKOUT STRENGTH> **Output clock buffer drive strength control**

01 WEAKER than default drive

00 DEFAULT drive strength

11 STRONGER than default drive strength (recommended for load capacitances > 5 pF)

10 MAXIMUM drive strength (recommended for load capacitances > 5 pF)

Table 10.

A7–A0 (hex)	D7	D6	D5	D4	D3	D2	D1	D0
11	0	0	<CURRENT DOUBLE> LVDS buffer current double		<LVDS CURRENT> LVDS buffer current programmability		<DATAOUT STRENGTH>	

D1–D0 <DATAOUT STRENGTH> **Output data buffer drive strength control**

01 WEAKER than default drive

00 DEFAULT drive strength

11 STRONGER than default drive strength (recommended for load capacitances > 5 pF)

10 MAXIMUM drive strength (recommended for load capacitances > 5 pF)

D3–D2 <LVDS CURRENT> **LVDS Current programmability**

00 3.5 mA

01 2.5 mA

10 4.5 mA

11 1.75 mA

D5–D4 <CURRENT DOUBLE> **LVDS Current double control**

00 default current, set by <LVDS CURR>

01 LVDS clock buffer current is doubled, 2x <LVDS CURR>

10 LVDS data and clock buffers current are doubled, 2x <LVDS CURR>

11 unused

Table 11.

A7–A0 (hex)	D7	D6	D5	D4	D3	D2	D1	D0
12	0	0	<LVDS TERMINATION> <i>Internal termination programmability</i>					

D5–D3 <LVDS DATA TERM> **Internal termination control for data outputs**

000	No internal termination
001	300 Ω
010	180 Ω
011	110 Ω
100	150 Ω
101	100 Ω
110	81 Ω
111	60 Ω

D2–D0 <LVDS CLK TERM> **Internal termination control for clock output**

000	No internal termination
001	300 Ω
010	180 Ω
011	110 Ω
100	150 Ω
101	100 Ω
110	81 Ω
111	60 Ω

Table 12.

A7–A0 (hex)	D7	D6	D5	D4	D3	D2	D1	D0
13	0	0	0	<OFFSET FREEZE>	0	0	0	0

D4 <OFFSET FREEZE> **Offset correction becomes inactive and the last estimated offset value is used to cancel the offset**

0	Offset correction active
1	Offset correction inactive

Table 13.

A7–A0 (hex)	D7	D6	D5	D4	D3	D2	D1	D0
14	<OVRD> <i>Over-ride bit</i>	0	<OUTPUT INTERFACE> <i>LVDS or CMOS interface</i>	<COARSE GAIN> <i>3.5 dB gain</i>	<REF> <i>Internal / External reference</i>	<POWER DOWN MODES>		

D2-D0 <POWER DOWN MODES>

000	Normal operation
001	Channel A output buffer disabled
010	Channel B output buffer disabled
011	Channel A and B output buffers disabled
100	Global power down
101	Channel A standby
110	Channel B standby
111	Multiplexed mode, MUX – (only with CMOS interface) Channel A and B data is multiplexed and output on DA10 to DA0 pins.

D3 <REF> Reference mode

0	Internal reference enabled
1	External reference enabled

D4 <COARSE GAIN> Coarse gain control

0	0 dB coarse gain
1	3.5 dB coarse gain

D5 <OUTPUT INTERFACE> Output interface selection

0	Parallel CMOS data outputs
1	DDR LVDS data outputs

D7 <OVRD> Over-ride bit – the LVDS/CMOS selection, power down and MUX modes can also be controlled using parallel pins. By setting <OVRD> = 1, register bits LVDS <CMOS> and <POWER DOWN MODES> will over-ride the settings of the parallel pins.

0	Disable over-ride
1	Enable over-ride

Table 14.

A7–A0 (hex)	D7	D6	D5	D4	D3	D2	D1	D0
16	0	0	0	DATA FORMAT> <i>2s complement or straight binary</i>	Bit / Byte wise (LVDS only)	<TEST PATTERNS>		

D2–D0 <TEST PATTERNS> Test Patterns to verify capture

- 000 Normal ADC operation
- 001 Outputs all zeros
- 010 Outputs all ones
- 011 Outputs toggle pattern
- 100 Outputs digital ramp
- 101 Outputs custom pattern
- 110 Unused
- 111 Unused

D3 Bit-wise/Byte-wise selection (DDR LVDS mode ONLY)

- 0 Bit wise – Odd bits (D1, D3, D5, D7, D9) on CLKOUT rising edge and Even bits (D0, D2, D4, D6, D8, D10) on CLKOUT falling edge
- 1 Byte wise – Lower 7 bits (D0-D6) at CLKOUT rising edge and Upper 4 bits (D7-D10) at CLKOUT falling edge

D4 <DATA FORMAT> Data format selection

- 0 2s complement
- 1 Straight binary

Table 15.

A7–A0 (hex)	D7	D6	D5	D4	D3	D2	D1	D0
17	0	0	0	0	<FINE GAIN> 0 to 6 dB gain in 0.5 dB steps			

D2–D0 <FINE GAIN> Gain programmability in 0.5 dB steps

- 0000 0 dB gain, default after reset
- 0001 0.5 dB gain
- 0010 1.0 dB gain
- 0011 1.5 dB gain
- 0100 2.0 dB gain
- 0101 2.5 dB gain
- 0110 3.0 dB gain
- 0111 3.5 dB gain
- 1000 4.0 dB gain
- 1001 4.5 dB gain
- 1010 5.0 dB gain
- 1011 5.5 dB gain
- 1100 6.0 dB gain
- Others Unused

Table 16.

A7–A0 (hex)	D7	D6	D5	D4	D3	D2	D1	D0
18	<CUSTOM LOW> Lower 5bits					0	0	0
19	0	0	<CUSTOM HIGH> Upper 6 bits					

D7-D4 <CUSTOM LOW>

5 lower bits of custom pattern available at the output instead of ADC data.

D5-D0 <CUSTOM HIGH>

6 upper bits of custom pattern available at the output instead of ADC data.

Table 17.

A7-A0 (hex)	D7	D6	D5	D4	D3	D2	D1	D0
1A	<LOW LATENCY>	<OFFSET TC> <i>Offset correction time constant</i>			<GAIN CORRECTION> <i>0 to 0.5 dB, steps of 0.05 dB</i>			

D2-D0 <GAIN CORRECTION> **Enables fine gain correction in steps of 0.05 dB (same correction applies to both channels)**

0000 0 dB gain, default after reset

0001 +0.5 dB gain

0010 +0.10 dB gain

0011 +0.15 dB gain

0100 +0.20 dB gain

0101 +0.25 dB gain

0110 +0.30 dB gain

0111 +0.35 dB gain

1000 +0.40 dB gain

1001 +0.45 dB gain

1010 +0.5 dB gain

D6-D4 <OFFSET TC> **Time constant of offset correction in number of clock cycles (seconds, for sampling frequency = 125MSPS)**

 000 2^{27} (1.1 s)

 001 2^{26} (0.55 s)

 010 2^{25} (0.27 s)

 011 2^{24} (0.13 s)

 100 2^{28} (2.15 s)

 101 2^{29} (4.3 s)

 110 2^{27} (1.1 s)

 111 2^{27} (1.1 s)

D7 <LOW LATENCY>

0 Default latency, 13 clock cycles

1 Low latency enabled, 9 clock cycles – Digital Processing Block is bypassed.

Table 18.

A7–A0 (hex)	D7	D6	D5	D4	D3	D2	D1	D0
1B	<OFFSET Enable> Offset correction enable	<SNRBoost Enable>	<FILTER COEFF SELECT> In-built or custom coefficients	<FILTER Enable> Enable decimation	<ODD TAP Enable>	<DECIMATION RATE> Decimate by 2,4,8		

- D2-D0** <DECIMATION RATE> [Decimation filters](#)
- 000 Decimate by 2 (pre-defined or user coefficients can be used)
 - 001 Decimate by 4 (pre-defined or user coefficients can be used)
 - 011 No decimation (Pre-defined coefficients are disabled, only custom coefficients are available)
 - 100 Decimate by 8 (Only custom coefficients are available)
- D3** <ODD TAP ENABLE>
- 0 Even taps enabled (24 coefficients)
 - 1 0 Odd taps enabled (23 coefficients)
- D4** <FILTER ENABLE>
- 0 Digital Filter Bypass
 - 1 Digital Filter Enabled
- D5** <FILTER COEFF SELECT>
- 0 Pre-defined coefficients are loaded in the filter
 - 1 User-defined coefficients are loaded in the filter (coefficients have to be loaded in registers – to -)
- D6** <SNRBoost Enable>
- 0 SNRBoost disabled
 - 1 SNRBoost enabled
- D7** <OFFSET Enable>
- 0 Offset correction disabled
 - 1 Offset correction enabled

Table 19.

A7–A0 (hex)	D7	D6	D5	D4	D3	D2	D1	D0
1C	<SNRBoost Coeff1>				<SNRBoost Coeff2>			

- D7-D4, D3-D0** <SNRBoost Coeff1>, <SNRBoost Coeff2> - The two coefficients can be set independently. See [SNR enhancement using SNRBoost](#) for details.

Table 20.

A7–A0 (hex)	D7	D6	D5	D4	D3	D2	D1	D0
1D	0	0	0	0	0	0	<DECIMATION FILTER FREQ BANDS>	

- D1-D0** <DECIMATION FILTER FREQ BAND> [Decimation filters](#)
- With decimate by 2, <DECIMATION RATE> = 000:
- 00 Low pass filter (-6 dB frequency at Fs/4)
 - 01 High pass filter (-6 dB frequency at Fs/4)
 - 10, 11 Unused
- With decimate by 4, <DECIMATION RATE> = 001:
- 00 Low pass filter (-3 dB frequency at Fs/8)
 - 01 Band pass filter (center frequency at 3Fs/16)
 - 10 Band pass filter (center frequency at 5Fs/16)
 - 11 High pass filter (-3 dB frequency at 3Fs/8)

PIN DESCRIPTION (CMOS INTERFACE)

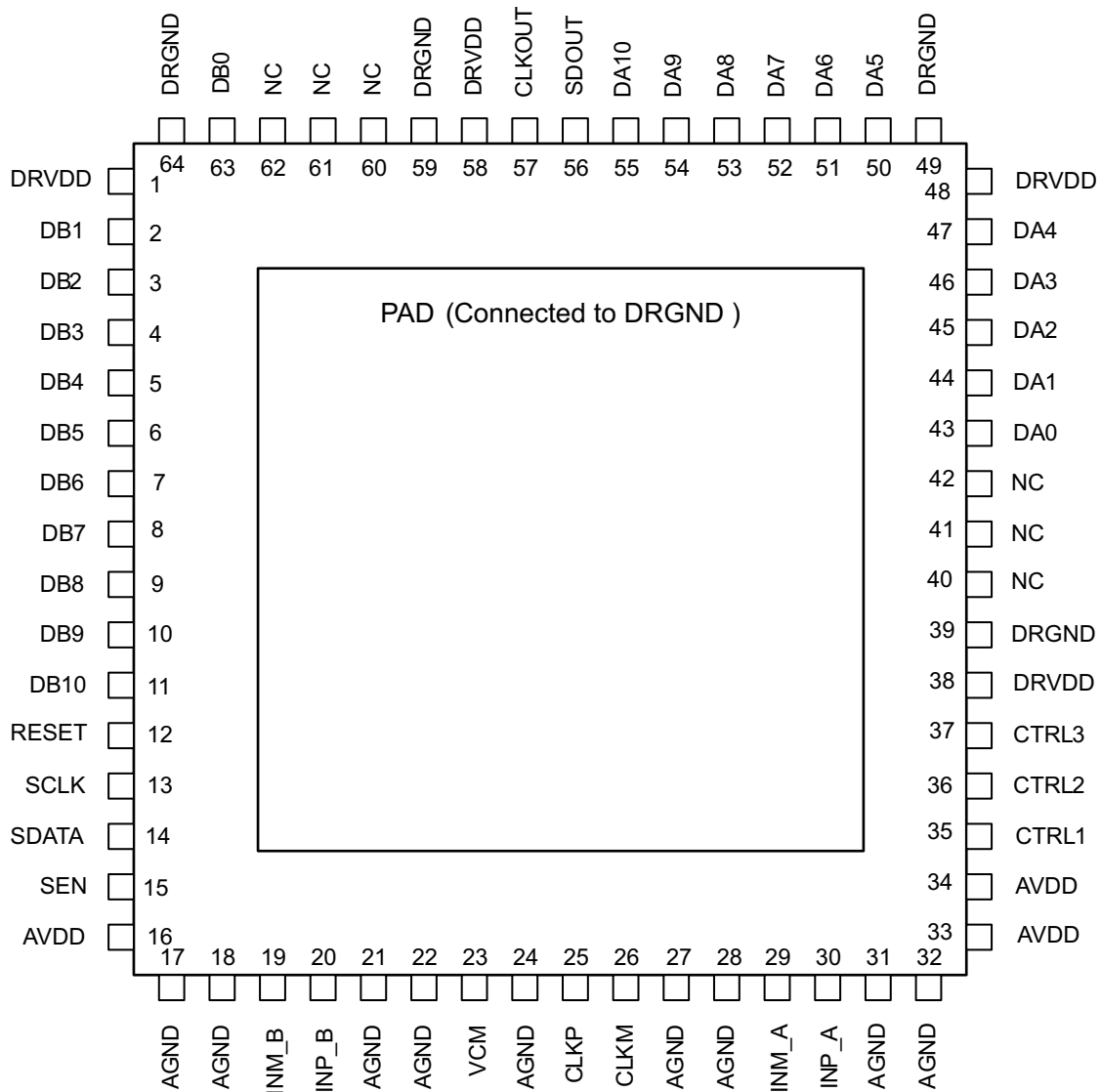

Pin Assignments (CMOS INTERFACE)

PIN NAME	DESCRIPTION	PIN NUMBER	NUMBER OF PINS
AVDD	Analog power supply	16, 33, 34	3
AGND	Analog ground	17, 18, 21, 22, 24, 27, 28, 31, 32	9
CLKP, CLKM	Differential input clock	25, 26	2
INM_A, INP_A	Differential input signal – channel A. When not used, the analog input pins (INM_A, INP_A) MUST be tied to VCM and CANNOT be floated.	29, 30	2
INM_B, INP_B	Differential input signal – channel B. When not used, the analog input pins (INM_A, INP_A) MUST be tied to VCM and CANNOT be floated.	19, 20	2
VCM	Internal reference mode – Common-mode voltage output. External reference mode – Reference input. The voltage forced on this pin sets the ADC internal references.	23	1
RESET	Serial interface RESET input. In serial interface mode, the user must initialize internal registers through hardware RESET by applying a high-going pulse on this pin or by using software reset (refer to Serial Interface section). In parallel interface mode, the user has to tie RESET pin permanently high . (SCLK, SDATA and SEN are used as parallel pin controls in this mode) The pin has an internal 100 kΩ pull-down resistor.	12	1
SCLK	This pin functions as serial interface clock input when RESET is low . It functions as analog control pin when RESET is tied high & controls coarse gain and internal/external reference selection. See Table 4 for details. The pin has an internal pull-down resistor to ground.	13	1
SDATA	This pin functions as serial interface data input when RESET is low. The pin has an internal pull-down resistor to ground.	14	1
SDOUT	It functions as serial data readout pin ONLY when <SERIAL READBACK> = 1. When <SERIAL READOUT> = 0, SDOUT pin is forced low or high by the device (and not put in high-impedance state). If serial readout is not used, SDOUT pin must be floated, and should not be connected on the board.	56	1
SEN	This pin functions as serial interface enable input when RESET is low . It functions as analog control pin when RESET is tied high & controls the output interface (LVDS/CMOS) and data format selection. See Table 5 for details. The pin has an internal pull-up resistor to AVDD.	15	1
CTRL1	These are digital logic input pins. Together they control various power down and multiplexed mode. see Table 6 for details	35	1
CTRL2		36	1
CTRL3		37	1
DA10 to DA0	Channel A 11-bit data outputs, CMOS	43–47, 50–55	11
DB10 to DB0	Channel B 11-bit data outputs, CMOS	2–11, 63	11
CLKOUT	CMOS Output clock	57	1
DRVDD	Digital supply	1, 38, 48, 58	4
DRGND	Digital ground	39, 49, 59, 64 and PAD	4
PAD	Digital ground. Solder the pad to the digital ground on the board using multiple vias for good electrical and thermal performance.	–	1
NC	Do not connect	40–42, 60–62	6

PIN DESCRIPTION (LVDS INTERFACE)

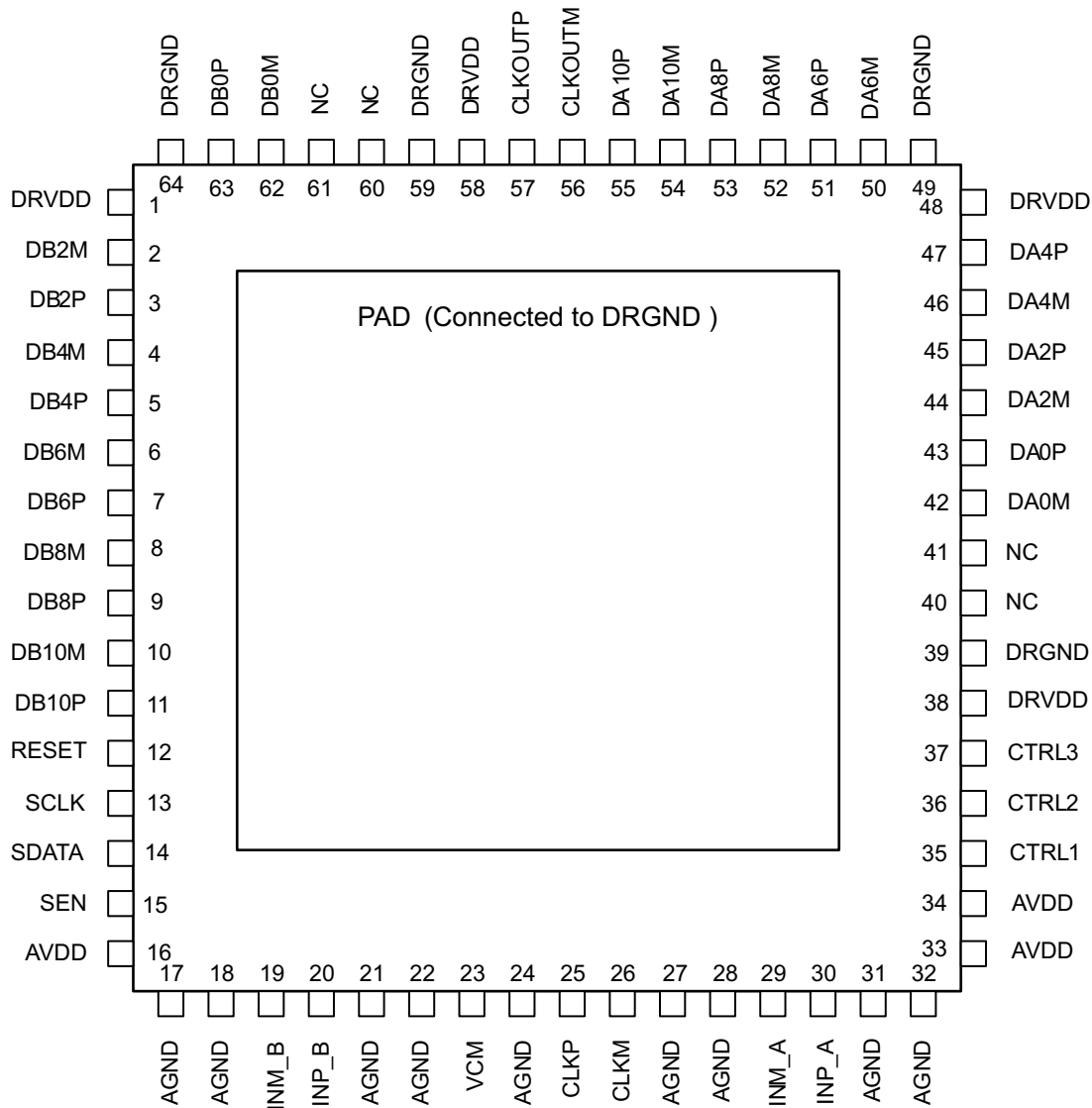

Pin Assignments (LVDS INTERFACE)

PIN NAME	DESCRIPTION	PIN NUMBER	NUMBER OF PINS
AVDD	Analog power supply	16, 33, 34	3
AGND	Analog ground	17, 18, 21, 22, 24, 27, 28, 31,32	9
CLKP, CLKM	Differential input clock	25, 26	2
INP_A, INM_A	Differential input signal – Channel A. When not used, the analog input pins (INM_A, INP_A) MUST be tied to VCM and CANNOT be floated.	29, 30	2
INP_B, INM_B	Differential input signal – Channel B. When not used, the analog input pins (INM_B, INP_B) MUST be tied to VCM and CANNOT be floated.	19, 20	2
VCM	Internal reference mode – Common-mode voltage output. External reference mode – Reference input. The voltage forced on this pin sets the ADC internal references.	23	1

Pin Assignments (LVDS INTERFACE) (continued)

PIN NAME	DESCRIPTION	PIN NUMBER	NUMBER OF PINS
RESET	Serial interface RESET input. In serial interface mode, the user must initialize internal registers through hardware RESET by applying a high-going pulse on this pin or by using software reset (refer to Serial Interface section). In parallel interface mode, the user has to tie RESET pin permanently high . (SCLK, SDATA and SEN are used as parallel pin controls in this mode) The pin has an internal 100 kΩ pull-down resistor.	12	1
SCLK	This pin functions as serial interface clock input when RESET is low . It functions as analog control pin when RESET is tied high and controls coarse gain and internal/external reference selection. See Table 4 for details. The pin has an internal pull-down resistor to ground.	13	1
SDATA	This pin functions as serial interface data input when RESET is low. The pin has an internal pull-down resistor to ground.	14	1
SEN	This pin functions as serial interface enable input when RESET is low . It functions as analog control pin when RESET is tied high & controls the output interface (LVDS/CMOS) and data format selection. See Table 5 for details. The pin has an internal pull-up resistor to AVDD.	15	1
CTRL1	These are digital logic input pins. Together they control various power down and multiplexed mode. See Table 6 for details.	35	1
CTRL2		36	1
CTRL3		37	1
NC	Do not connect	40, 41, 60, 61	4
DA0P	Channel A Differential output data 0 and D0 multiplexed, true	43	1
DA0M	Channel A Differential output data 0 and D0 multiplexed, complement	42	1
DA2P	Channel A Differential output data D1 and D2 multiplexed, true	45	1
DA2M	Channel A Differential output data D1 and D2 multiplexed, complement	44	1
DA4P	Channel A Differential output data D3 and D4 multiplexed, true	47	1
DA4M	Channel A Differential output data D3 and D4 multiplexed, complement	46	1
DA6P	Channel A Differential output data D5 and D6 multiplexed, true	51	1
DA6M	Channel A Differential output data D5 and D6 multiplexed, complement	50	1
DA8P	Channel A Differential output data D7 and D8 multiplexed, true	53	1
DA8M	Channel A Differential output data D7 and D8 multiplexed, complement	52	1
DA10P	Channel A Differential output data D9 and D10 multiplexed, true	55	1
DA10M	Channel A Differential output data D9 and D10 multiplexed, complement	54	1
CLKOUTP	Differential output clock, true	57	1
CLKOUTM	Differential output clock, complement	56	1
DB0P	Channel B Differential output data 0 and D0 multiplexed, true	63	1
DB0M	Channel B Differential output data 0 and D0 multiplexed, complement	62	1
DB2P	Channel B Differential output data D1 and D2 multiplexed, true	3	1
DB2M	Channel B Differential output data D1 and D2 multiplexed, complement	2	1
DB4P	Channel B Differential output data D3 and D4 multiplexed, true	5	1
DB4M	Channel B Differential output data D3 and D4 multiplexed, complement	4	1
DB6P	Channel B Differential output data D5 and D6 multiplexed, true	7	1
DB6M	Channel B Differential output data D5 and D6 multiplexed, complement	6	1
DB8P	Channel B Differential output data D7 and D8 multiplexed, true	9	1
DB8M	Channel B Differential output data D7 and D8 multiplexed, complement	8	1
DB10P	Channel B Differential output data D9 and D10 multiplexed, true	11	1
DB10M	Channel B Differential output data D9 and D10 multiplexed, complement	10	1
DRVDD	Digital supply	1, 38, 48, 58	4
DRGND	Digital ground	39, 49, 59, 64 and PAD	4

Pin Assignments (LVDS INTERFACE) (continued)

PIN NAME	DESCRIPTION	PIN NUMBER	NUMBER OF PINS
PAD	Digital ground. Solder the pad to the digital ground on the board using multiple vias for good electrical and thermal performance.	–	1

TYPICAL CHARACTERISTICS

All plots are at 25°C, AVDD = 3.3 V, DRVDD = 3.3 V, sampling frequency = 125 MSPS, sine wave clock, 50% clock duty cycle, –1 dBFS differential analog input, internal reference mode, 0 dB gain, applies to CMOS and LVDS interfaces (unless otherwise noted).

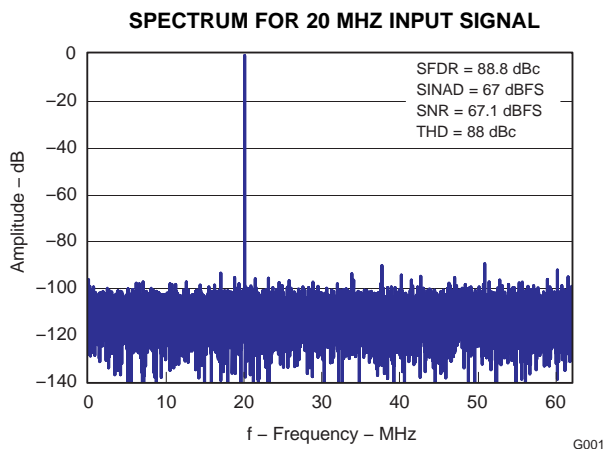

Figure 9.

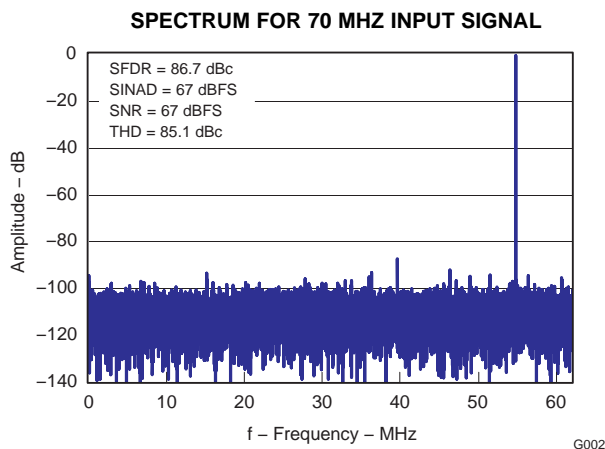

Figure 10.

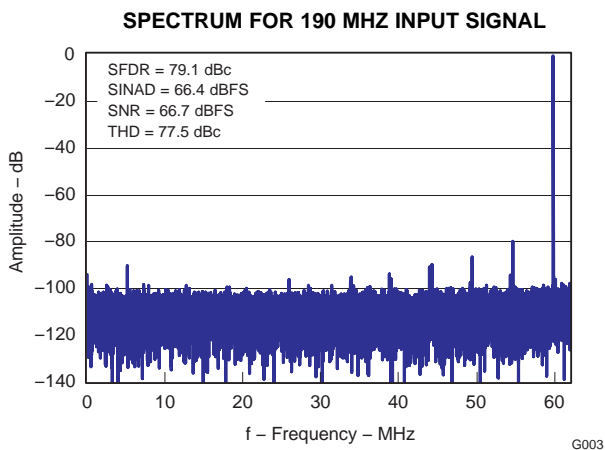

Figure 11.

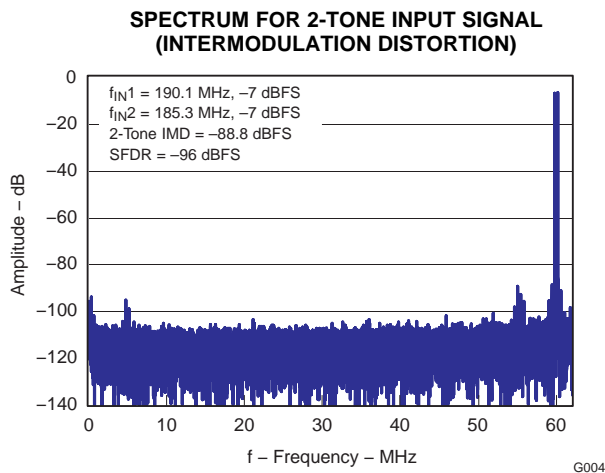

Figure 12.

TYPICAL CHARACTERISTICS (continued)

All plots are at 25°C, AVDD = 3.3 V, DRVDD = 3.3 V, sampling frequency = 125 MSPS, sine wave clock, 50% clock duty cycle, -1 dBFS differential analog input, internal reference mode, 0 dB gain, applies to CMOS and LVDS interfaces (unless otherwise noted).

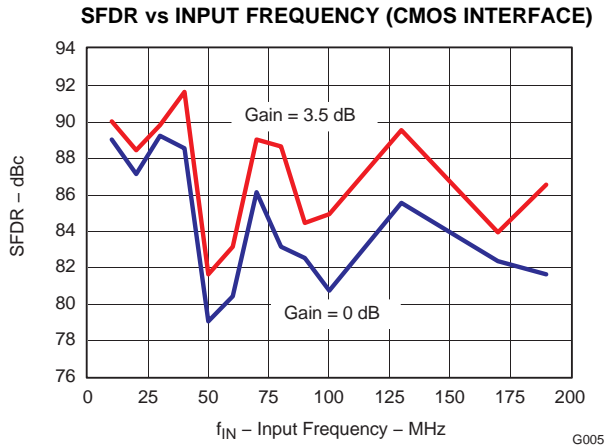

Figure 13.

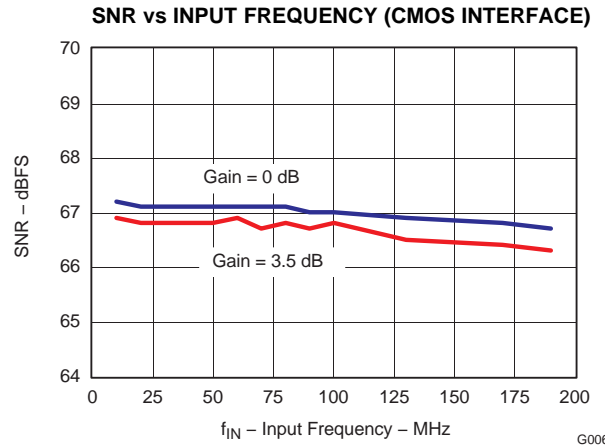

Figure 14.

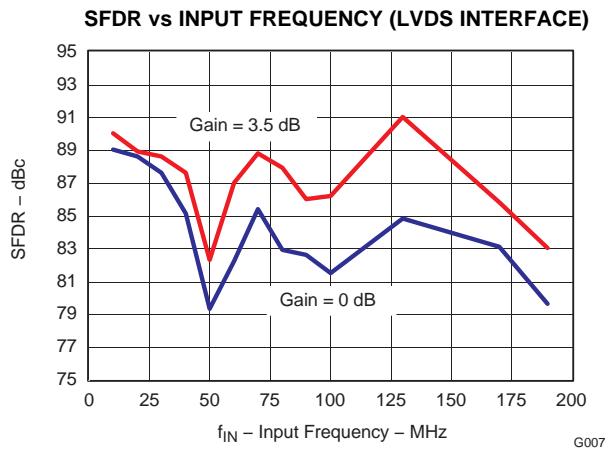

Figure 15.

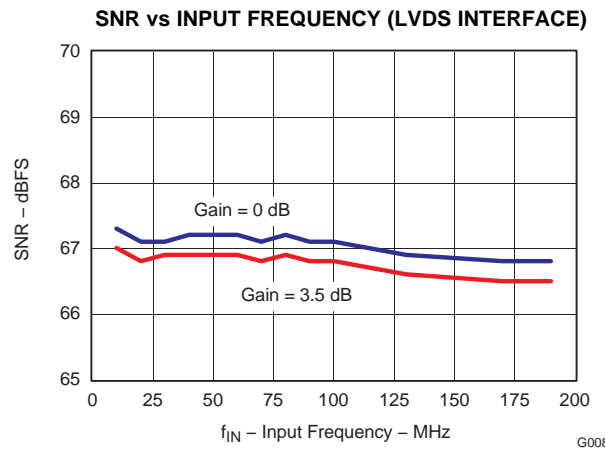

Figure 16.

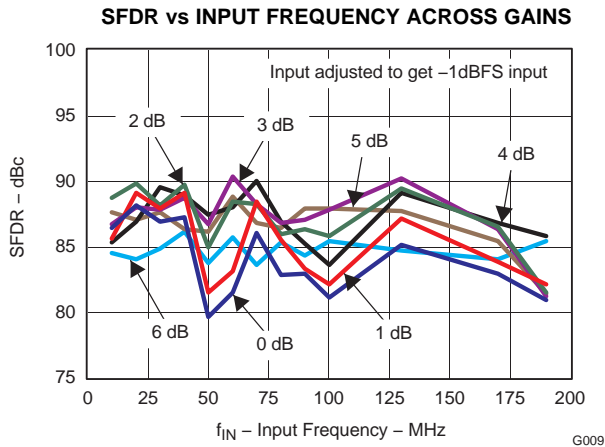

Figure 17.

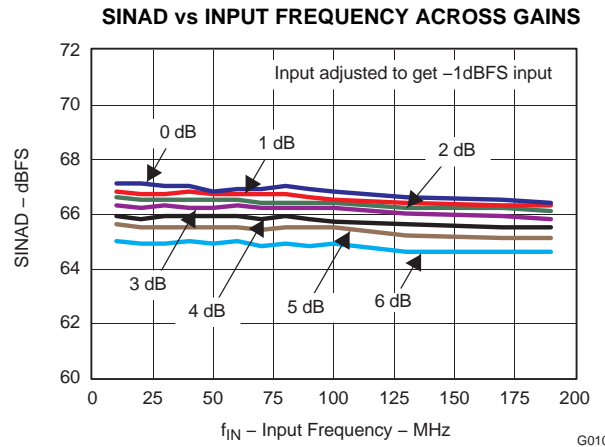

Figure 18.

TYPICAL CHARACTERISTICS (continued)

All plots are at 25°C, AVDD = 3.3 V, DRVDD = 3.3 V, sampling frequency = 125 MSPS, sine wave clock, 50% clock duty cycle, -1 dBFS differential analog input, internal reference mode, 0 dB gain, applies to CMOS and LVDS interfaces (unless otherwise noted).

PERFORMANCE vs AVDD SUPPLY

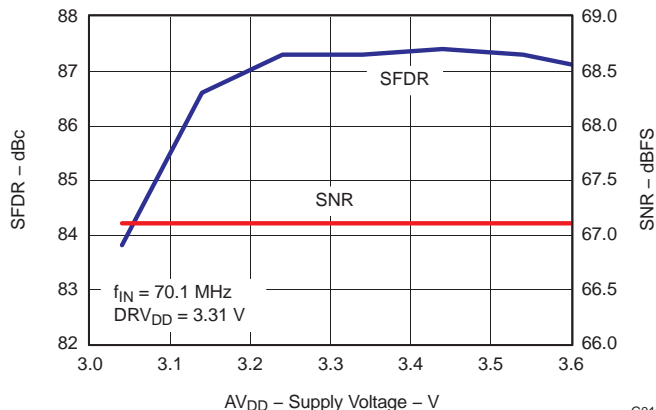

Figure 19.

PERFORMANCE vs DRVDD SUPPLY

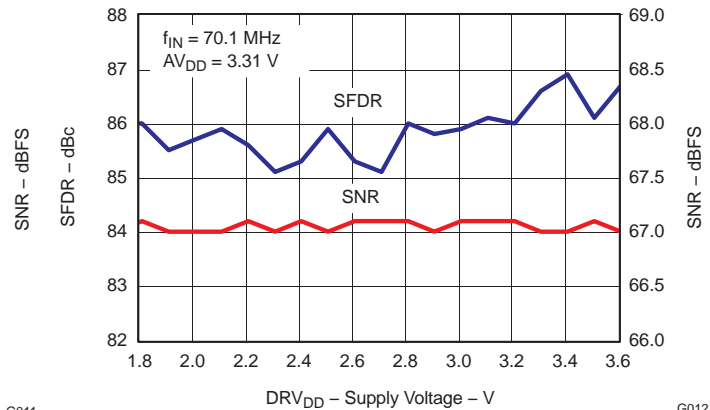

Figure 20.

PERFORMANCE vs TEMPERATURE

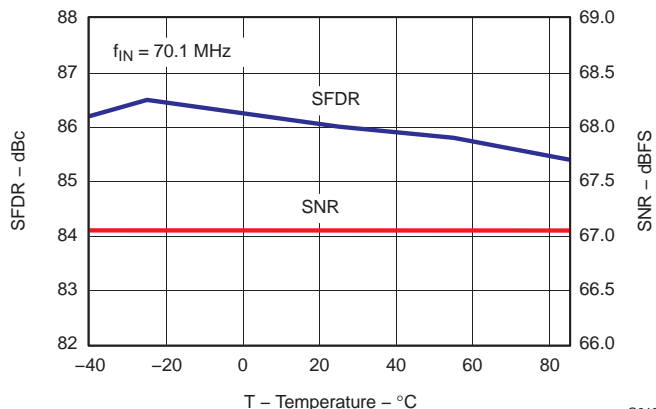

Figure 21.

PERFORMANCE vs INPUT AMPLITUDE

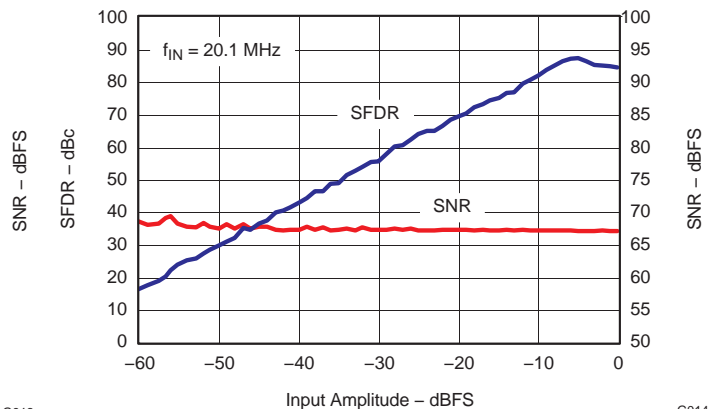

Figure 22.

PERFORMANCE vs INPUT CLOCK AMPLITUDE

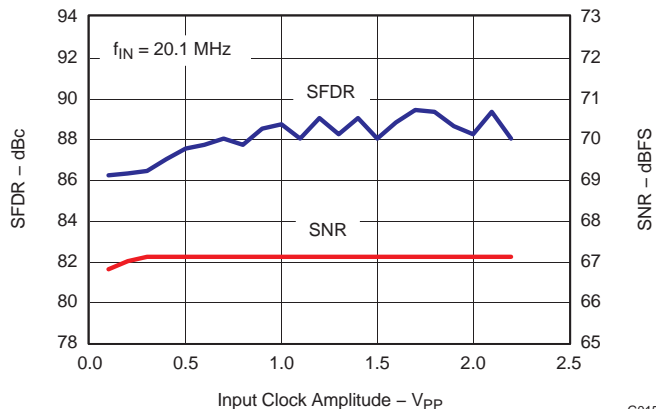

Figure 23.

PERFORMANCE vs INPUT CLOCK DUTY CYCLE

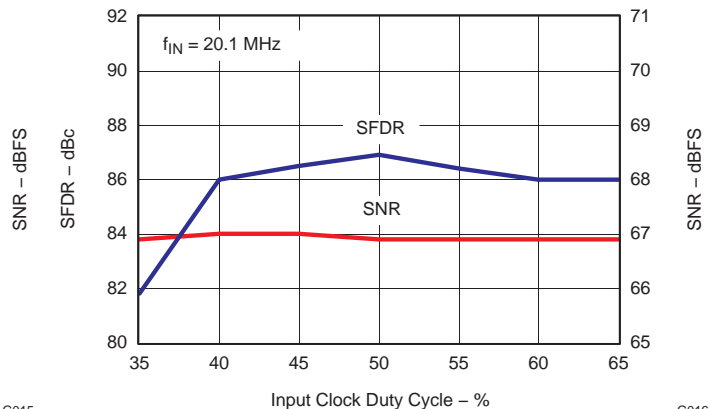

Figure 24.

TYPICAL CHARACTERISTICS (continued)

All plots are at 25°C, AVDD = 3.3 V, DRVDD = 3.3 V, sampling frequency = 125 MSPS, sine wave clock, 50% clock duty cycle, -1 dBFS differential analog input, internal reference mode, 0 dB gain, applies to CMOS and LVDS interfaces (unless otherwise noted).

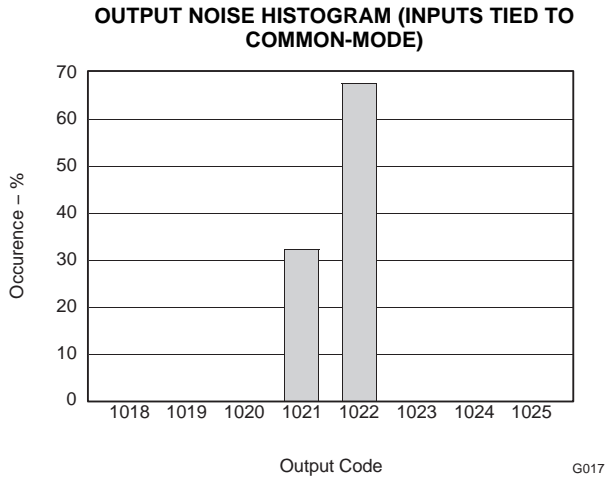

Figure 25.

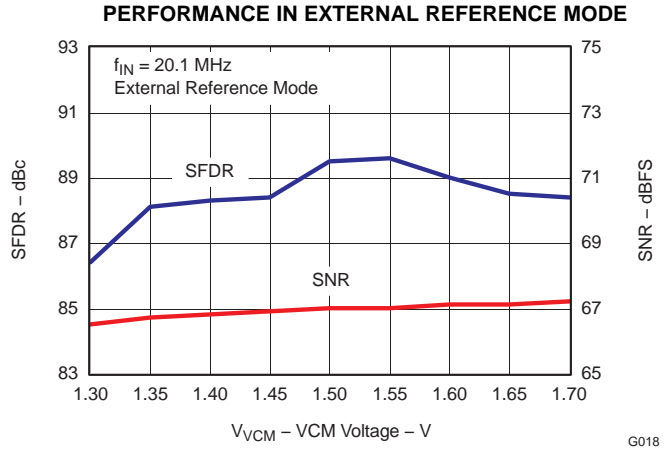

Figure 26.

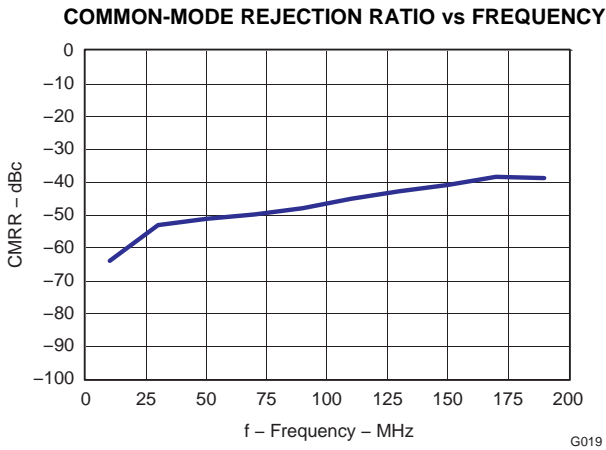

Figure 27.

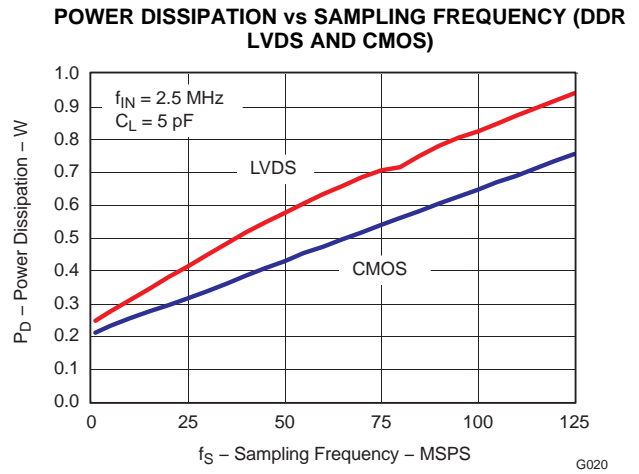

Figure 28.

DRVDD CURRENT vs SAMPLING FREQUENCY ACROSS LOAD CAPACITANCE (CMOS)

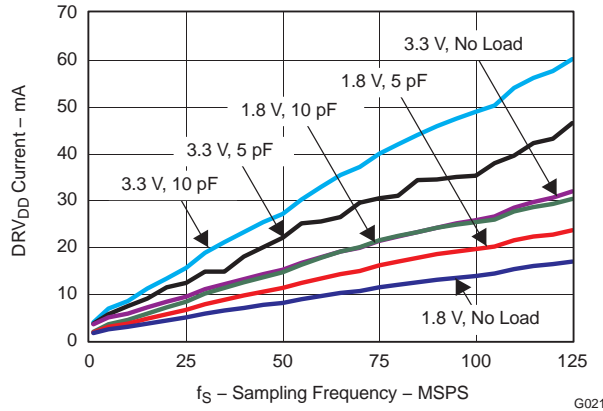

Figure 29.

APPLICATION INFORMATION

THEORY OF OPERATION

ADS62C15 is a low power 11-bit dual channel pipeline ADC family fabricated in a CMOS process using switched capacitor techniques.

The conversion process is initiated by a rising edge of the external input clock. Once the signal is captured by the input sample and hold, the input sample is sequentially converted by a series of small resolution stages, with the outputs combined in a digital correction logic block. At every clock edge the sample propagates through the pipeline resulting in a data latency of 14 clock cycles. The output is available as 11-bit data, in DDR LVDS or CMOS and coded in either straight offset binary or binary 2s complement format.

ANALOG INPUT

The analog input consists of a switched-capacitor based differential sample and hold architecture.

This differential topology results in very good AC performance even for high input frequencies at high sampling rates. The INP and INM pins have to be externally biased around a common-mode voltage of 1.5 V, available on VCM pin. For a full-scale differential input, each input pin INP, INM has to swing symmetrically between $V_{CM} + 0.5\text{ V}$ and $V_{CM} - 0.5\text{ V}$, resulting in a 2 V_{PP} differential input swing. The maximum swing is determined by the internal reference voltages REFP (2.5 V nominal) and REFM (0.5 V, nominal).

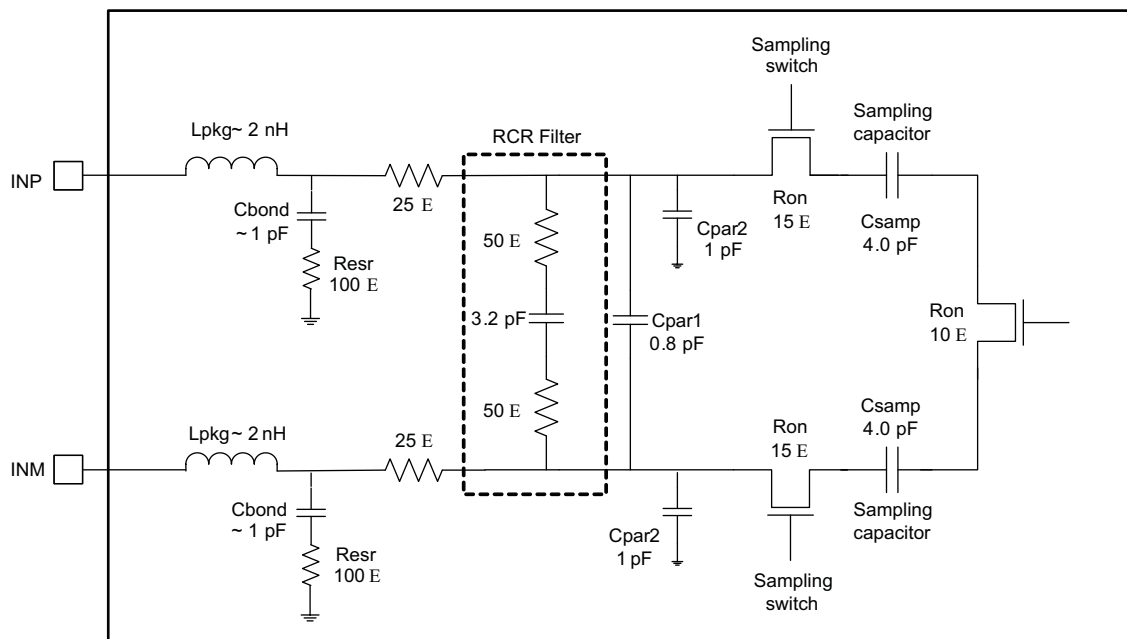

Figure 30. Analog Input Equivalent Circuit

The input sampling circuit has a high 3-dB bandwidth that extends up to 450 MHz (measured from the input pins to the sampled voltage).

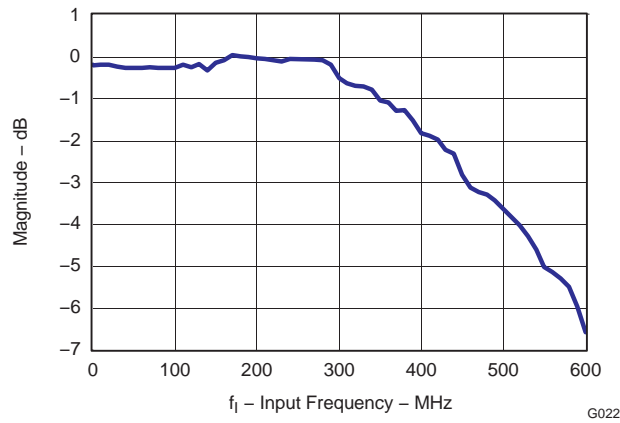

Figure 31. ADC Analog Bandwidth

Drive Circuit Requirements

For optimum performance, the analog inputs must be driven differentially. This improves the common-mode noise immunity and even order harmonic rejection. A $<5 \Omega$ resistor in series with each input pin is recommended to damp out ringing caused by the package parasitics.

It is also necessary to present low impedance (50Ω) for the common mode switching currents. This can be achieved by using two resistors from each input terminated to the common mode voltage (VCM).

In addition, the drive circuit may have to be designed to provide a low insertion loss over the desired frequency range and matched impedance to the source. While doing this, the ADC input impedance must be considered. [Figure 32](#) and [Figure 33](#) show the impedance ($Z_{in} = R_{in} || C_{in}$) looking into the ADC input pins.

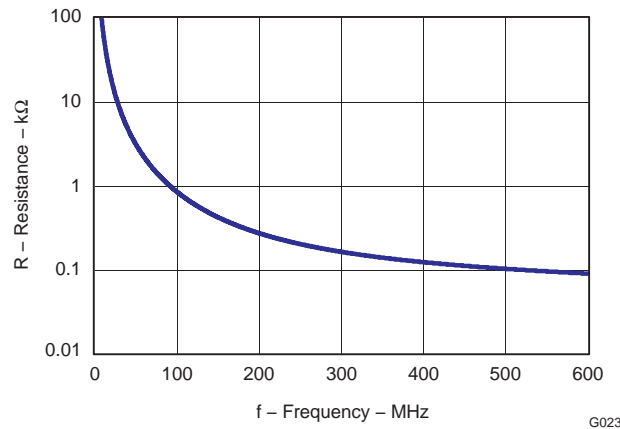

Figure 32. ADC Analog Input Resistance (R_{in}) Across Frequency

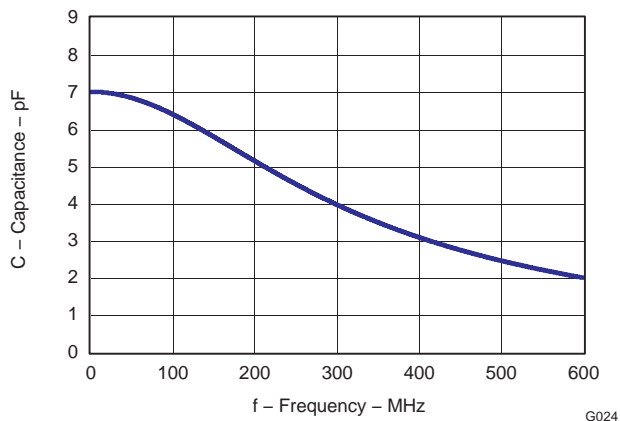

Figure 33. ADC Analog Input Capacitance (C_{in}) Across Frequency

Using RF-Transformer Based Drive Circuits

Figure 34 shows a configuration using a single 1:1 turns ratio transformer (for example, Coilcraft WBC1-1) that can be used for low input frequencies (about 100 MHz). The single-ended signal is fed to the primary winding of the RF transformer. The transformer is terminated on the secondary side. Putting the termination on the secondary side helps to shield the kickbacks caused by the sampling circuit from the RF transformer’s leakage inductances. The termination is accomplished by two resistors connected in series, with the center point connected to the 1.5 V common mode (VCM pin). The value of the termination resistors (connected to common mode) has to be low (<100 Ω) to provide a low-impedance path for the ADC common-mode switching currents.

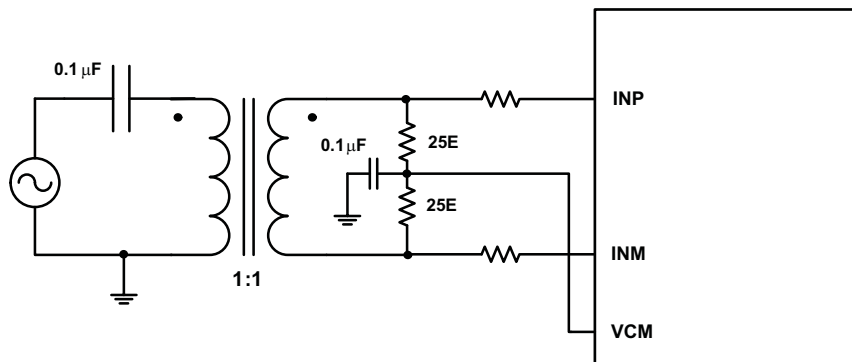

Figure 34. Drive Circuit at Low Input Frequencies

At high input frequencies, the mismatch in the transformer parasitic capacitance (between the windings) results in degraded even-order harmonic performance. Connecting two identical RF transformers back-to-back helps minimize this mismatch, and good performance is obtained for high frequency input signals. Figure 35 shows an example using two transformers (Coilcraft WBC1-1). An additional termination resistor pair (enclosed within the shaded box) may be required between the two transformers to improve the balance between the P and M sides. The center point of this termination must be connected to ground.

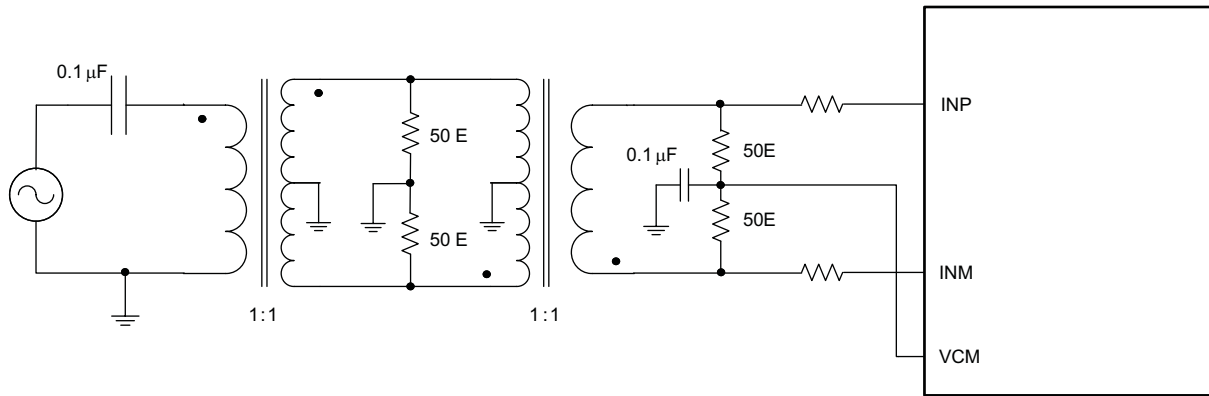

Figure 35. Drive Circuit at High Input Frequencies

Using Differential Amplifier Drive Circuits

Figure 36 shows a drive circuit using a differential amplifier (TI's THS4509) to convert a single-ended input to differential output that can be interface to the ADC analog input pins. In addition to the single-ended to differential conversion, the amplifier also provides gain (10 dB). RFIL helps to isolate the amplifier outputs from the switching input of the ADC. Together with CFIL it also forms a low-pass filter that band-limits the noise (and signal) at the ADC input. As the amplifier output is ac-coupled, the common-mode voltage of the ADC input pins is set using two 200 Ω resistors connected to VCM.

The amplifier output can also be dc-coupled. Using the output common-mode control of the THS4509, the ADC input pins can be biased to 1.5 V. In this case, use +4 V and –1 V supplies for the THS4509 so that its output common-mode voltage (1.5 V) is at mid-supply.

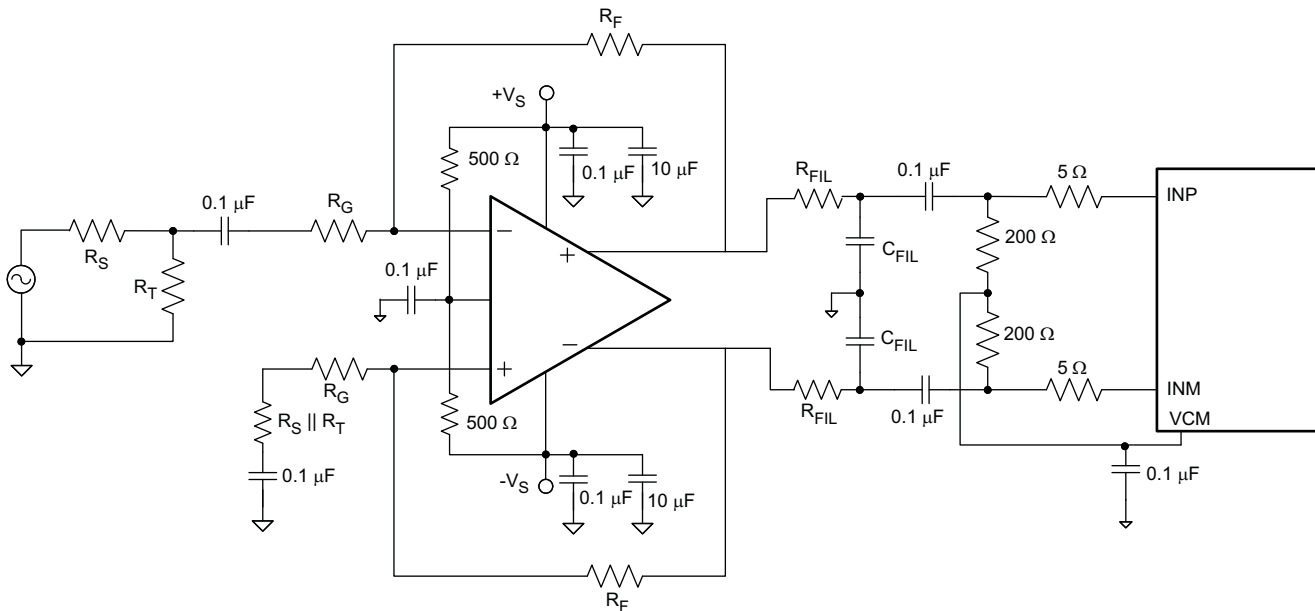

Figure 36. Drive Circuit Using the THS4509

Input Common-Mode

To ensure a low-noise common-mode reference, the VCM pin is filtered with a 0.1µF low-inductance capacitor connected to ground. The VCM pin is designed to directly drive the ADC inputs. The input stage of the ADC sinks a common-mode current in the order of 165 µA (at 125 MSPS). Equation 1 describes the dependency of the common-mode current and the sampling frequency.

$$\frac{165 \mu\text{A} \times F_s}{125 \text{ MSPS}} \tag{1}$$

This equation helps to design the output capability and impedance of the CM driving circuit accordingly.

REFERENCE

ADS62C15 has built-in internal references REFP and REFM, requiring no external components. Design schemes are used to linearize the converter load seen by the references; this and the on-chip integration of the requisite reference capacitors eliminates the need for external decoupling. The full-scale input range of the converter can be controlled in the external reference mode as explained below. The internal or external reference modes can be selected by programming the serial interface register bit (REF).

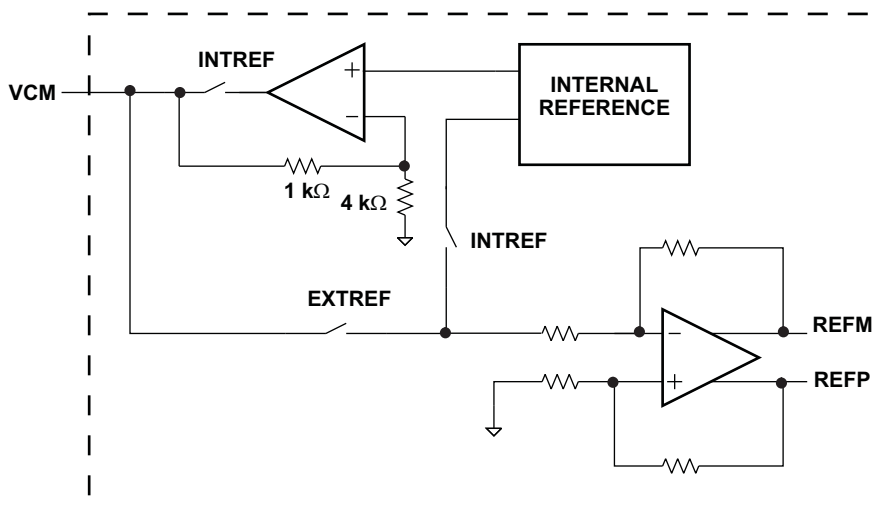

Figure 37. Reference Section

Internal Reference

When the device is in internal reference mode, the REFP and REFM voltages are generated internally. Common-mode voltage (1.5 V nominal) is output on VCM pin, which can be used to externally bias the analog input pins.

External Reference

When the device is in external reference mode, the VCM acts as a reference input pin. The voltage forced on the VCM pin is buffered and gained by 1.33 internally, generating the REFP and REFM voltages. The differential input voltage corresponding to full-scale is given in Equation 2.

$$\text{Full-scale differential input pp} = (\text{Voltage forced on VCM}) \times 1.33 \tag{2}$$

In this mode, the 1.5 V common-mode voltage to bias the input pins has to be generated externally.

SNR Enhancement Using SNRBoost

SNRBoost technology makes it possible to overcome SNR limitations due to quantization noise. With **SNRBoost**, enhanced SNR can be obtained for any bandwidth (less than Nyquist, $F_s/2$ [Table 1](#)). The SNR improvement is achieved *without affecting the default harmonic performance*. The mode is disabled by default after reset and can be enabled using register bit <SNRBoost Enable>.

The mode is disabled by default after reset and can be enabled using register bit <SNRBoost Enable>. When it is enabled, the noise floor in the spectrum acquires a typical bath-tub shape as shown in [Figure 38](#). The bath-tub is centered around a specific frequency (called “center frequency”). The center frequency is located mid-way between two corner frequencies, which are specified by the SNRBoost coefficients (Register bits <SNRBoost Coeff1> and SNRBoost Coeff2>).

[Table 21](#) shows the relation between each coefficient and its corner frequency. By choosing appropriate coefficients, the bath-tub can be positioned over the frequency range 0 to $F_s/2$ ([Table 22](#) shows some examples). By positioning the bath-tub within the desired signal band, SNR improvement can be achieved (see [Table 1](#)). Note that as the bandwidth is increased, the amount of SNR improvement reduces.

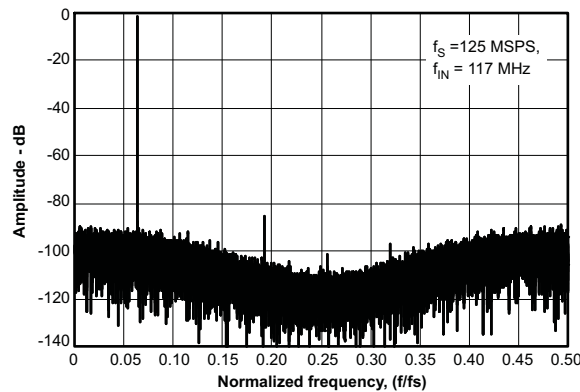

Figure 38. Spectrum with **SNRBoost** enabled

Table 21. Setting The Corner Frequency

SNRBoost Coefficient value	Normalized Corner Frequency (ffs)	SNRBoost Coefficient value	Normalized Corner Frequency (ffs)
7	0.420	F	0.230
6	0.385	E	0.210
5	0.357	D	0.189
4	0.333	C	0.167
3	0.311	B	0.143
2	0.290	A	0.115
1	0.270	9	0.080
0	0.250	8	0.000

Table 22. Positioning The Center Frequency (Some Examples)

SNRBoost Coefficient1 <SNRBoost Coeff1>	Normalized Corner Frequency1 (f/fs)	SNRBoost Coefficient2 <SNRBoost Coeff2>	Normalized Corner Frequency2 (f/fs)	Center Frequency ⁽¹⁾
0	0.250	0	0.250	Fs x 0.25
F	0.230	1	0.270	Fs x 0.25
6	0.385	2	0.290	Fs x 0.3375
D	0.189	B	0.143	Fs x 0.166
9	0.080	7	0.420	Fs x 0.25

(1) Center frequency = $F_s \times (\text{Normalized corner freq1} + \text{Normalized corner freq2})/2$

SNRBoost does not introduce any group delay in the input signal path. The ADC latency increases by one clock cycle to 15 compared to 14 clock cycles with the mode disabled. When it is enabled using the serial interface, the mode becomes fully active 4 input clock cycles after the 16th SCLK falling edge. When it is disabled, normal data (without SNRBoost) resumes after one clock cycle.

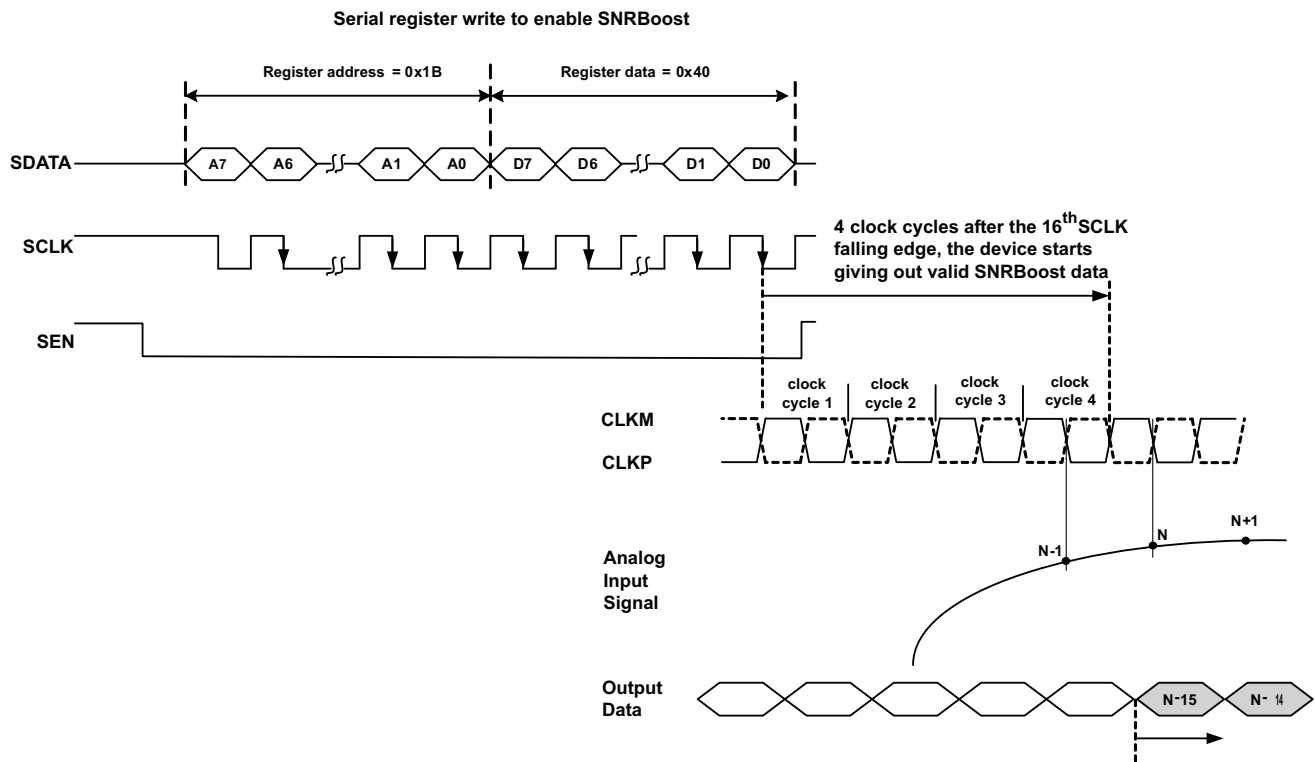

Figure 39. SNRBoost Active Delay

COARSE GAIN AND PROGRAMMABLE FINE GAIN

ADS62C15 includes gain settings that can be used to get improved SFDR performance (over 0dB gain mode). For each gain setting, the analog input full-scale range scales proportionally, as shown in Table 23.

The coarse gain is a fixed setting of 3.5 dB and is designed to improve SFDR with little degradation in SNR. The fine gain is programmable in 0.5 dB steps from 0 to 6 dB; however the SFDR improvement is achieved at the expense of SNR. So, the programmable fine gain makes it possible to trade-off between SFDR and SNR. The coarse gain makes it possible to get best SFDR but without losing SNR significantly.

The gains can be programmed using the serial interface (bits COARSE GAIN and FINE GAIN). Note that the default gain after reset is 0dB.

Table 23. Full-Scale Range Across Gains

GAIN, dB	TYPE	FULL-SCALE, V _{PP}
0	Default after reset	2V
3.5	Coarse (fixed)	1.34
0.5	Fine (programmable)	1.89
1.0		1.78
1.5		1.68
2.0		1.59
2.5		1.50
3.0		1.42
3.5		1.34
4.0		1.26
4.5		1.19
5.0		1.12
5.5		1.06
6.0		1.00

CLOCK INPUT

The clock inputs can be driven differentially (SINE, LVPECL or LVDS) or single-ended (LVCMOS), with little or no difference in performance between them. The common-mode voltage of the clock inputs is set to VCM using internal 5 kΩ resistors as shown in Figure 40. This allows using transformer-coupled drive circuits for sine wave clock or ac-coupling for LVPECL, LVDS clock sources (Figure 42 and Figure 43).

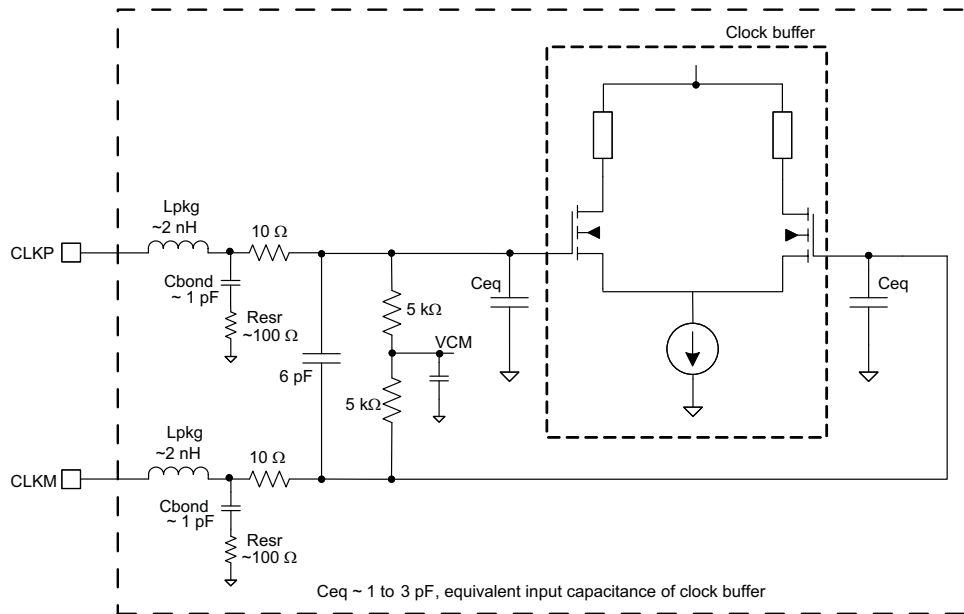

Figure 40. Internal Clock Buffer

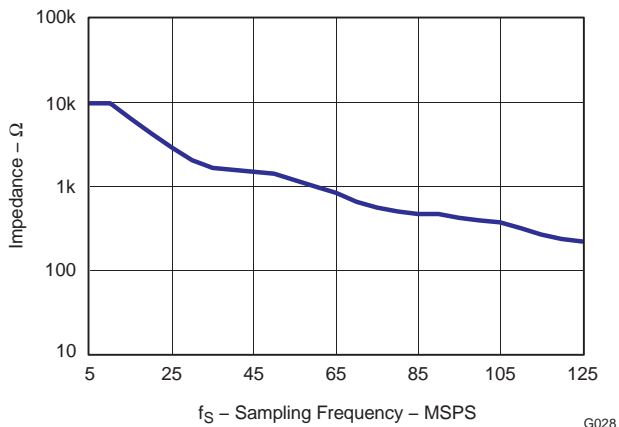

Figure 41. Clock Input Impedance

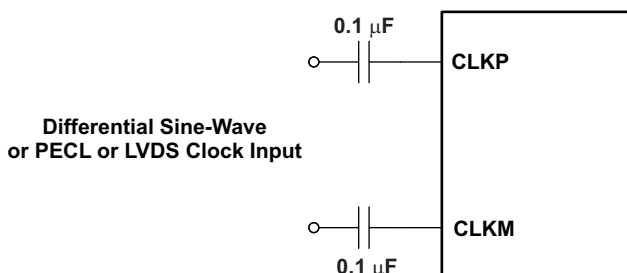

Figure 42. Differential Clock Driving Circuit

Single-ended CMOS clock can be ac-coupled to the CLKP input, with CLKM connected to ground with a 0.1-μF capacitor, as shown in Figure 43.

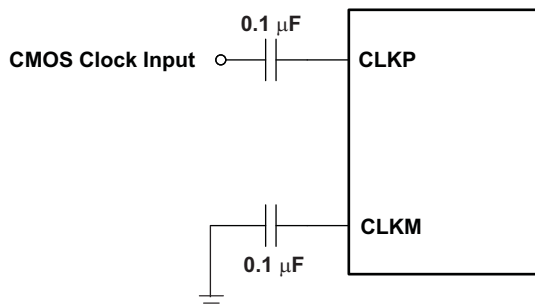

Figure 43. Single-Ended Clock Driving Circuit

For best performance, the clock inputs have to be driven differentially, reducing susceptibility to common-mode noise. For high input frequency sampling, it is recommended to use a clock source with very low jitter. Bandpass filtering of the clock source can help reduce the effect of jitter. There is no change in performance with a non-50% duty cycle clock input.

POWER DOWN

ADS62C15 has three power down modes – power down global, individual channel standby and individual channel output buffer disable. These can be set using either the serial register bits or using the control pins CTRL1 to CTRL3.

Table 24. Power Down Modes

POWER DOWN MODES	CONFIGURE USING				WAKE-UP TIME
	SERIAL INTERFACE <POWER DOWN MODES>	PARALLEL CONTROL PINS			
		CTRL1	CTRL2	CTRL3	
Normal operation	000	low	low	low	—
Channel A output buffer disabled	001	low	low	high	Fast (100 ns)
Channel B output buffer disabled	010	low	high	low	Fast (100 ns)
Channel A and B output buffer disabled	011	low	high	high	Fast (100 ns)
Channel A and B powered down	100	high	low	low	Slow (15 μ S)
Channel A standby	101	high	low	high	Fast (100 ns)
Channel B standby	110	high	high	low	Fast (100 ns)
Multiplexed (MUX) mode – Output data of channel A and B is multiplexed and available on DA13 to DA0 pins.	111	high	high	high	—

Power Down Global

In this mode, the entire chip including both the A/D converters, internal reference and the output buffers are powered down resulting in reduced total power dissipation of about 50 mW. The output buffers are in high impedance state. The wake-up time from the global power down to data becoming valid in normal mode is typically 15 μ s.

Channel Standby (Individual or Both Channels)

This mode allows the individual ADCs to be powered down. The internal references are active & this results in fast wake-up time, about 100 ns. The total power dissipation in standby is about 482 mW.

Output Buffer Disable (Individual or Both Channels)

Each channel's output buffer can be disabled and put in high impedance state -- wakeup time from this mode is fast, about 100 ns.

Input Clock Stop

In addition to the above, the converter enters a low-power mode when the input clock frequency falls below 1 MSPS. The power dissipation is about 140 mW.

POWER SUPPLY SEQUENCE

During power-up, the AVDD and DRVDD supplies can come up in any sequence. The two supplies are separated in the device. Externally, they can be driven from separate supplies or derived from a single supply.

DIGITAL OUTPUT INFORMATION

ADS62C15 provides 11 bit data per channel and a common output clock synchronized with the data. The output interface can be either parallel CMOS or DDR LVDS voltage levels and can be selected using serial register bit <OUTPUT INTERFACE> or parallel pin SEN.

Parallel CMOS Interface

In the CMOS mode, the output buffer supply (DRVDD) can be operated over a wide range from 1.8 V to 3.3 V (typical). Each data bit is output on separate pin as CMOS voltage level, every clock cycle (see Figure 44).

For DRVDD > 2.2 V, it is recommended to use the CMOS output clock (CLKOUT) to latch data in the receiving chip. The rising edge of CLKOUT can be used to latch data in the receiver, even at the highest sampling speed. It is recommended to minimize the load capacitance seen by data and clock output pins by using short traces to the receiver. Also, match the output data and clock traces to minimize the skew between them.

For DRVDD < 2.2 V, it is recommended to use external clock (for example, input clock delayed to get desired setup/hold times).

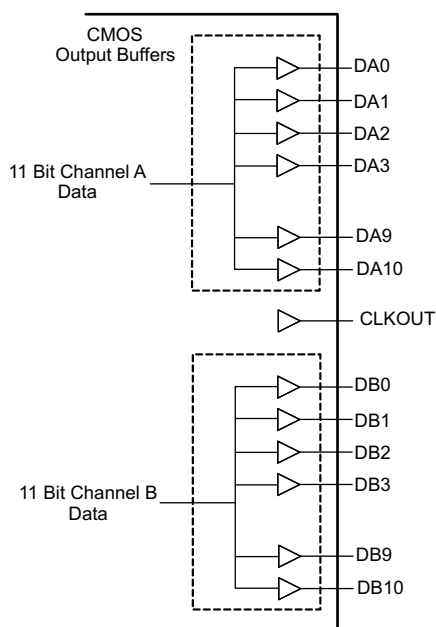

Figure 44. CMOS Output Interface

Output Buffer Strength Programmability

Switching noise (caused by CMOS output data transitions) can couple into the analog inputs during the instant of sampling and degrade the SNR. The coupling and SNR degradation increases as the output buffer drive is made stronger. To minimize this, ADS62C15 CMOS output buffers are designed with controlled drive strength to get best SNR. The default drive strength also ensures wide data stable window for load capacitances up to 5 pF and DRVDD supply voltage >2.2 V.

To ensure wide data stable window for load capacitance > 5 pF, there exists option to increase the output data and clock drive strengths using the serial interface ([DATAOUT STRENGTH](#) and [CLKOUT STRENGTH](#)). Note that for DRVDD supply voltage <2.2 V, it is recommended to use maximum drive strength (for any value of load capacitance).

CMOS Mode Power Dissipation

With CMOS outputs, the DRVDD current scales with the sampling frequency and the load capacitance on every output pin. The maximum DRVDD current occurs when each output bit toggles between 0 and 1 every clock cycle. In actual applications, this condition is unlikely to occur. The actual DRVDD current would be determined by the average number of output bits switching, which is a function of the sampling frequency and the nature of the analog input signal.

$$\text{Digital current due to CMOS output switching} = C_L \times \text{DRVDD} \times (N \times F_{\text{AVG}}),$$

where C_L = load capacitance, $N \times F_{\text{AVG}}$ = average number of output bits switching.

Figure 29 shows the current with various load capacitances across sampling frequencies at 2 MHz analog input frequency.

DDR LVDS Interface

The LVDS interface works only with 3.3 V DRVDD supply. In this mode, the 11 data bits of each channel and a common output clock are available as LVDS (Low Voltage Differential Signal) levels. Two successive data bits are multiplexed and output on each LVDS differential pair every clock cycle (DDR – Double Data Rate, Figure 46).

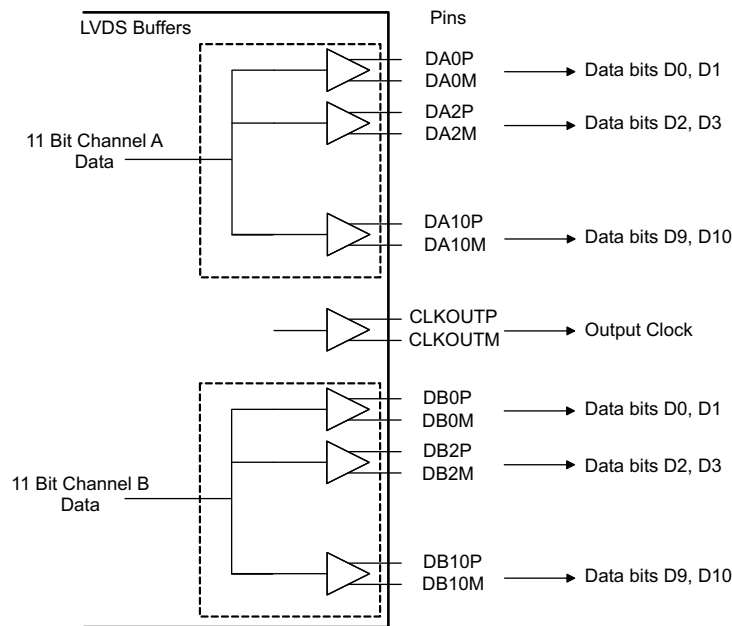

Figure 45. DDR LVDS Outputs

Odd data bits D1, D3, D5, D7, D9 are output at the rising edge of CLKOUTP and even data bits D0, D2, D4, D6, D8, D10 are output at the falling edge of CLKOUTP. Both the rising and falling edges of CLKOUTP have to be used to capture all the data bits.

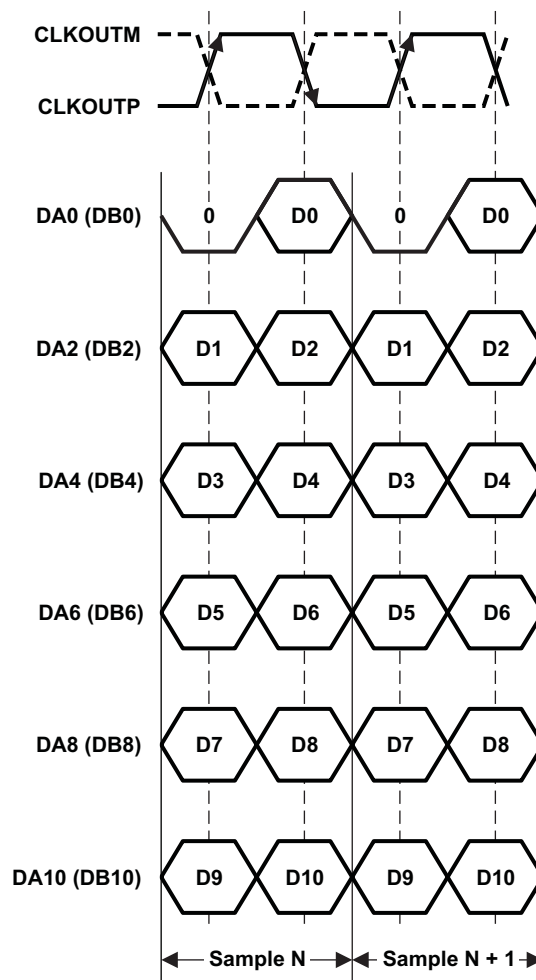

Figure 46. DDR LVDS Interface

LVDS Buffer Current Programmability

The default LVDS buffer output current is 3.5 mA. When terminated by 100 Ω , this results in a 350-mV single-ended voltage swing (700-mV_{PP} differential swing). The LVDS buffer currents can also be programmed to 2.5 mA, 4.5 mA, and 1.75 mA ([LVDS CURRENT](#)). In addition, there exists a current double mode, where this current is doubled for the data and output clock buffers (register bits [CURRENT DOUBLE](#)).

LVDS Buffer Internal Termination

An internal termination option is available (using the serial interface), by which the LVDS buffers are differentially terminated inside the device. The termination resistances available are –300 Ω , 185 Ω , and 150 Ω (nominal with $\pm 20\%$ variation). Any combination of these three terminations can be programmed; the effective termination is the parallel combination of the selected resistances. This results in eight effective terminations from open (no termination) to 60 Ω .

The internal termination helps to absorb any reflections coming from the receiver end, improving the signal integrity. With 100 Ω internal and 100 Ω external termination, the voltage swing at the receiver end is halved (compared to no internal termination). The voltage swing can be restored by using the LVDS current double mode. [Figure 47](#) and [Figure 48](#) compare the LVDS eye diagrams without and with 100 Ω internal termination. With internal termination, the eye looks clean even with 10 pF load capacitance (from each output pin to ground). The terminations can be programmed using register bits ([LVDS TERMINATION](#)).

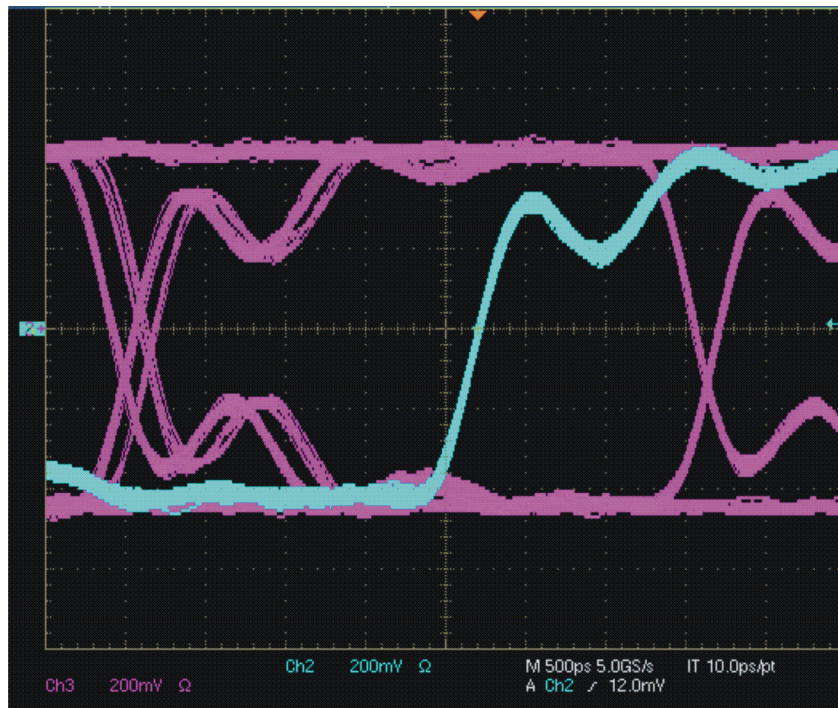

Figure 47. LVDS Eye Diagram – No Internal Termination, External Termination = 100 Ω

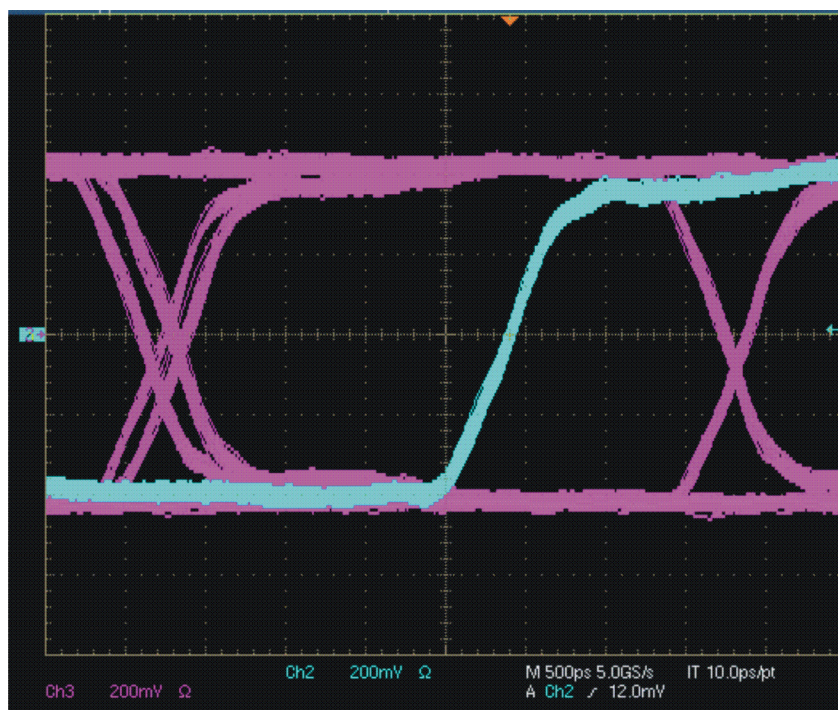

Figure 48. LVDS Eye Diagram – With 100Ω Internal Termination, External termination = 100 Ω and LVDS current double mode enabled

Output Data Format

Two output data formats are supported – 2s complement and straight binary. They can be selected using the serial interface register bit <DATA FORMAT> or controlling the SEN pin in parallel configuration mode.

In the event of an input voltage overdrive, the digital outputs go to the appropriate full scale level. For a positive overdrive, the output code is 0x7FF in offset binary output format, and 0x3FF in 2s complement output format. For a negative input overdrive, the output code is 0x000 in offset binary output format and 0x400 in 2s complement output format.

Multiplexed Output mode

This mode is available only with CMOS interface. In this mode, the digital outputs of both the channels are multiplexed and output on a single bus (DB0-DB10 pins), as per the timing diagram shown in Figure 49. The channel A output pins (DA0-DA10) are tri-stated. Since the output data rate on the DB bus is effectively doubled, this mode is recommended only for low sampling frequencies (<65 MSPS).

This mode can be enabled using register bits <POWER DOWN MODES> or using the parallel pins CTRL1 -3 ().

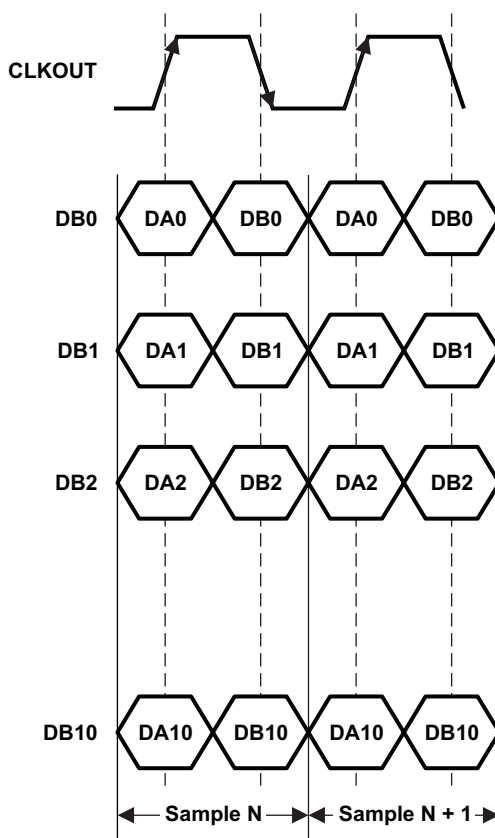
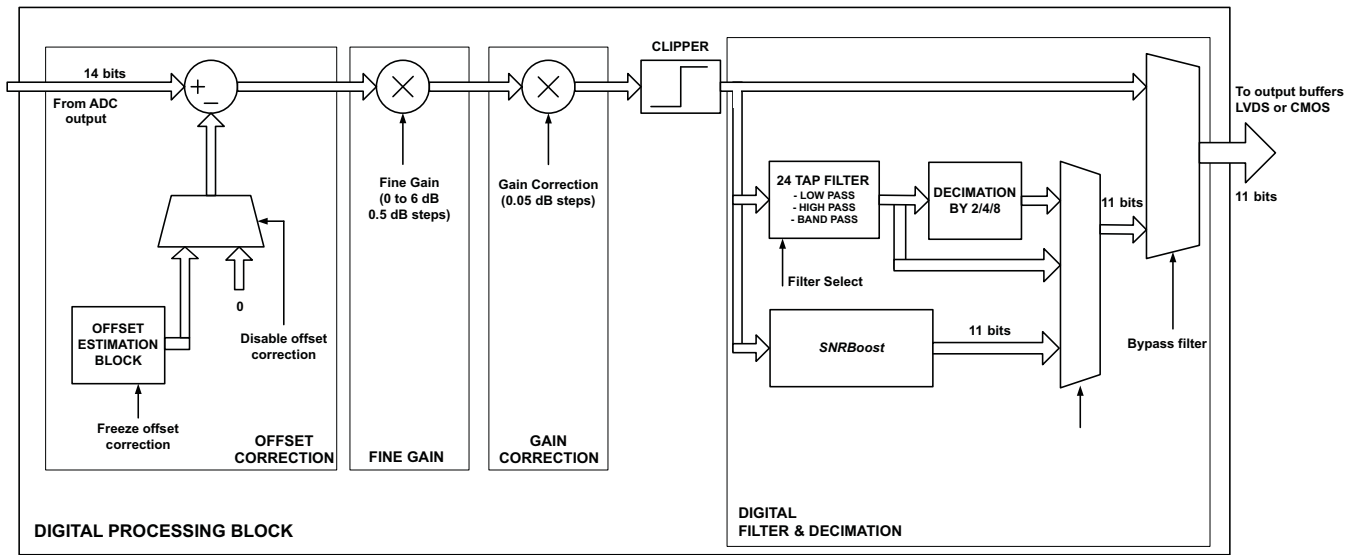

Figure 49. Multiplexed mode – Output Timing

Low Latency Mode

The default latency of ADS62C15 is 14 clock cycles. For applications, which cannot tolerate large latency, ADS62C15 includes a special mode with 10 clock cycles latency. In the low latency condition, the Digital Processing block is bypassed and its features (offset correction, fine gain, decimation filters) are not available.

DETAILS OF DIGITAL PROCESSING BLOCK



NOTE: The digital filter block is bypassed when the SNRBoost mode is enabled.

Figure 50. Digital Processing Block Diagram

Offset Correction

ADS62C15 has an internal offset correction algorithm that estimates and corrects dc offset up to ±10mV. The correction can be enabled using the serial register bit ([OFFSET LOOP EN](#)). Once enabled, the algorithm estimates the channel offset and applies the correction every clock cycle. The time constant of the correction loop is a function of the sampling clock frequency. The time constant can be controlled using register bits ([OFFSET LOOP TC](#)) as described in [Table 25](#).

Table 25. Time Constant of Offset Correction Algorithm

<OFFSET LOOP TC> D6-D5-D4	Time constant (TC _{CLK}), number of clock cycles	Time constant, sec (=TC _{CLK} × 1/Fs) ⁽¹⁾
000	2 ²⁷	1.1
001	2 ²⁶	0.55
010	2 ²⁵	0.27
011	2 ²⁴	0.13
100	2 ²⁸	2.15
101	2 ²⁹	4.3
110	2 ²⁷	1.1
111	2 ²⁷	1.1

(1) Sampling frequency, Fs = 125 MSPS

It is also possible to freeze the offset correction using the serial interface (<OFFSET LOOP FREEZE>). Once frozen, the offset estimation becomes inactive and the last estimated value is used for correction every clock cycle. Note that the offset correction is disabled by default after reset.

Figure 51 shows the time response of the offset correction algorithm, after it is enabled.

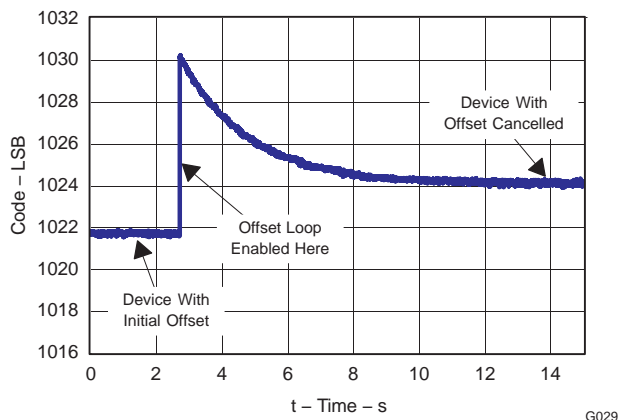

Figure 51. Time Response of Offset Correction

Gain Correction

ADS62C15 has ability to make fine corrections to the ADC channel gain. The corrections can be done in steps of 0.05 dB, up to a maximum of 0.5 dB, using the register bits ([GAIN CORRECTION](#)). Only positive corrections are supported and the same correction applies to both the channels.

Table 26. Gain Correction Values

<GAIN CORRECTION> D3-D2-D1-D0	Amount of correction, dB
0000	0
0001	+0.05
0010	+0.1
0011	+0.15
0100	+0.20
0101	+0.25
0110	+0.30
0111	+0.35
1000	+0.40
1001	+0.45
1010	+0.5
Other combinations	Unused

Decimation Filters⁽¹⁾

ADS62C15 includes option to decimate the ADC output data with in-built low pass, high pass or band pass filters.

The decimation rate and type of filter can be selected using register bits ([DECIMATION RATE](#)) and ([DECIMATION FILTER TYPE](#)). Decimation rates of 2, 4 or 8 are available and either low pass, high pass or band pass filters can be selected (see [Table 27](#)). By default, the decimation filter is disabled – use register bit [<DECIMATION ENABLE>](#) to enable it.

Table 27. Decimation Filter Modes

COMBINATION OF DECIMATION RATES AND FILTER TYPES		<DECIMATION RATE>			<DECIMATION FILTER FREQ BAND>		<FILTER COEFF SELECT>	<DECIMATION ENABLE>
DECIMATION	TYPE OF FILTER							
Decimate by 2	In-built low pass filter (pass band = 0 to Fs/4)	0	0	0	0	0	0	1
	In-built high pass filter (pass band = Fs/4 to Fs/2)	0	0	0	0	1	0	1
Decimate by 4	In-built low pass filter (pass band = 0 to Fs/8)	0	0	1	0	0	0	1
	In-built 2 nd band pass filter (pass band = Fs/8 to Fs/4)	0	0	1	0	1	0	1
	In-built 3 rd band pass filter (pass band = Fs/4 to 3Fs/8)	0	0	1	1	0	0	1
	In-built last band pass filter (pass band = 3Fs/8 to Fs/2)	0	0	1	1	1	0	1
Decimate by 2	Custom filter (user programmable coefficients)	0	0	0	X	X	1	1
Decimate by 4	Custom filter (user programmable coefficients)	0	0	1	X	X	1	1
Decimate by 8	Custom filter (user programmable coefficients)	1	0	0	X	X	1	1
No decimation	Custom filter (user programmable coefficients)	0	1	1	X	X	1	0

Decimation Filter Equation

The decimation filter is implemented as 24-tap FIR with symmetrical coefficients (each coefficient is 12-bit signed). The filter equation is:

$$y(n) = \left(\frac{1}{2^{11}}\right) \times [h_0 \times x(n) + h_1 \times x(n - 1) + h_2 \times x(n - 2) + \dots + h_{11} \times x(n - 11) + h_{11} \times x(n - 12) + \dots + h_1 \times x(n - 22) + h_0 \times x(n - 23)] \tag{3}$$

By setting the register bit [<ODD TAP ENABLE>](#) = 1, a 23-tap FIR is implemented:

$$y(n) = \left(\frac{1}{2^{11}}\right) \times [h_0 \times x(n) + h_1 \times x(n - 1) + h_2 \times x(n - 2) + \dots + h_{10} \times x(n - 10) + h_{11} \times x(n - 11) + h_{10} \times x(n - 12) + \dots + h_1 \times x(n - 21) + h_0 \times x(n - 22)] \tag{4}$$

In the above equations,

- h0, h1 ...h11 are 12-bit signed representation of the coefficients,
- x(n) is the input data sequence to the filter
- y(n) is the filter output sequence

Pre-defined Coefficients

The in-built filter types (low pass, high pass and band pass) use pre-defined coefficients. The frequency response of the in-built filters is shown in [Figure 52](#) and [Figure 53](#).

⁽¹⁾ The digital filter block is bypassed when the SNRBoost mode is enabled.

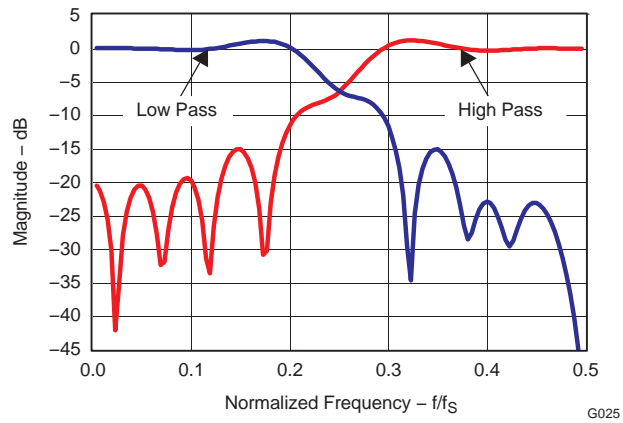

Figure 52. Decimate by 2 Filter Response

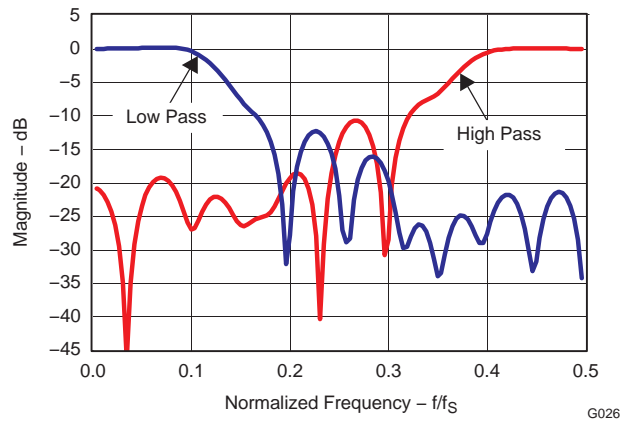

Figure 53. Decimate by 4 Filter Response

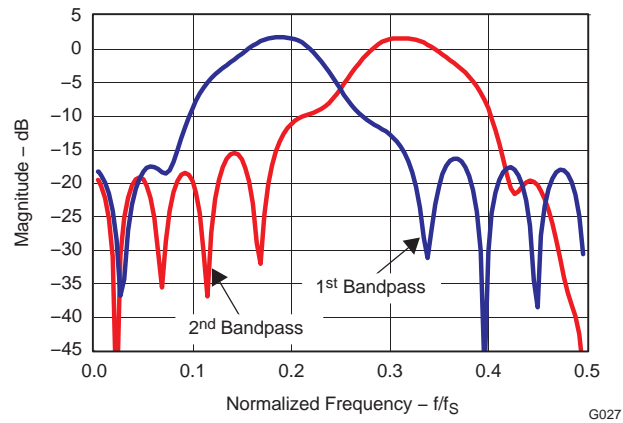

Figure 54. Decimate by 4 Bandpass Response

Table 28. Predefined Coefficients for Decimation by 2 Filters

COEFFICIENTS	DECIMATE BY 2	
	LOW PASS FILTER	HIGH PASS FILTER
h0	23	-22
h1	-37	-65
h2	-6	-52
h3	68	30
h4	-36	66
h5	-61	-35
h6	35	-107
h7	118	38
h8	-100	202
h9	-197	-41
h10	273	-644
h11	943	1061

Table 29. Predefined Coefficients for Decimation by 4 Filters

COEFFICIENTS	DECIMATE BY 4			
	LOW PASS FILTER	1st BAND PASS FILTER	2ND BAND PASS FILTER	HIGH PASS FILTER
h0	-17	-7	-34	32
h1	-50	19	-34	-15
h2	71	-47	-101	-95
h3	46	127	43	22
h4	24	73	58	-8
h5	-42	0	-28	-81
h6	-100	86	-5	106
h7	-97	117	-179	-62
h8	8	-190	294	-97
h9	202	-464	86	310
h10	414	-113	-563	-501
h11	554	526	352	575

Custom Filter Coefficients with Decimation

The filter coefficients can also be programmed by the user (custom). For custom coefficients, set the register bit ([FILTER COEFF SELECT](#)) and load the coefficients (h0 to h11) in registers 1E to 2F using the serial interface ([Table 30](#)) as:

$$\text{Register content} = 12 \text{ bit signed representation of } [\text{real coefficient value} \times 2^{11}]$$

Custom Filter Coefficients without Decimation

The filter with custom coefficients can also be used with the decimation mode disabled. In this mode, the filter implementation is 12-tap FIR:

 $y(n) =$

$$\left(\frac{1}{2^{11}}\right)[h_6 \times x(n) + h_7 \times x(n - 1) + h_8 \times x(n - 2) + \dots + h_{11} \times x(n - 5) + h_{11} \times x(n - 6) + \dots + h_7 \times x(n - 10) + h_6 \times x(n - 11)] \quad (5)$$

Table 30. Register Map of Custom Coefficients

A7–A0 (hex)	D7	D6	D5	D4	D3	D2	D1	D0
1E	Coefficient h0 <7:0>							
1F	Coefficient h1 <3:0>				Coefficient h0 <11:8>			
20	Coefficient h1 <11:4>							
21	Coefficient h2 <7:0>							
22	Coefficient h3 <3:0>				Coefficient h2 <11:8>			
23	Coefficient h3 <11:4>							
24	Coefficient h4 <7:0>							
25	Coefficient h5 <3:0>				Coefficient h4 <11:8>			
26	Coefficient h5 <11:4>							
27	Coefficient h6 <7:0>							
28	Coefficient h7 <3:0>				Coefficient h6 <11:8>			
29	Coefficient h7 <11:4>							
2A	Coefficient h8 <7:0>							
2B	Coefficient h9 <3:0>				Coefficient h8 <11:8>			
2C	Coefficient h9 <11:4>							
2D	Coefficient h10 <7:0>							
2E	Coefficient h11 <3:0>				Coefficient h10 <11:8>			
2F	Coefficient h11 <11:4>							

BOARD DESIGN CONSIDERATIONS

Grounding

A single ground plane is sufficient to give good performance, provided the analog, digital, and clock sections of the board are cleanly partitioned. See the EVM User Guide ([SLAU237](#)) for details on layout and grounding.

Supply Decoupling

As the ADS62C15 already includes internal decoupling, minimal external decoupling can be used without loss in performance. Note that decoupling capacitors can help filter external power supply noise, so the optimum number of capacitors would depend on the actual application. The decoupling capacitors should be placed very close to the converter supply pins.

It is recommended to use separate supplies for the analog and digital supply pins to isolate digital switching noise from sensitive analog circuitry. In case only a single 3.3-V supply is available, it should be routed first to AVDD. It can then be tapped and isolated with a ferrite bead (or inductor) with decoupling capacitor, before being routed to DRVDD.

Exposed Thermal Pad

It is necessary to solder the exposed pad at the bottom of the package to a ground plane for best thermal performance. For detailed information, see application notes ***QFN Layout Guidelines*** ([SLOA122](#)) and ***QFN/SON PCB Attachment*** ([SLUA271](#)).

DEFINITION OF SPECIFICATIONS

Analog Bandwidth – The analog input frequency at which the power of the fundamental is reduced by 3 dB with respect to the low frequency value.

Aperture Delay – The delay in time between the rising edge of the input sampling clock and the actual time at which the sampling occurs. This delay will be different across channels. The maximum variation is specified as aperture delay variation (channel-channel).

Aperture Uncertainty (Jitter) – The sample-to-sample variation in aperture delay.

Clock Pulse Width/Duty Cycle – The duty cycle of a clock signal is the ratio of the time the clock signal remains at a logic high (clock pulse width) to the period of the clock signal. Duty cycle is typically expressed as a percentage. A perfect differential sine-wave clock results in a 50% duty cycle.

Maximum Conversion Rate – The maximum sampling rate at which certified operation is given. All parametric testing is performed at this sampling rate unless otherwise noted.

Minimum Conversion Rate – The minimum sampling rate at which the ADC functions.

Differential Nonlinearity (DNL) – An ideal ADC exhibits code transitions at analog input values spaced exactly 1 LSB apart. The DNL is the deviation of any single step from this ideal value, measured in units of LSBs.

Integral Nonlinearity (INL) – The INL is the deviation of the ADC's transfer function from a best fit line determined by a least squares curve fit of that transfer function, measured in units of LSBs.

Gain Error – The gain error is the deviation of the ADC's actual input full-scale range from its ideal value. The gain error is given as a percentage of the ideal input full-scale range. The gain error does not include the error caused by the internal reference deviation from ideal value. This is specified separately as internal reference error. The maximum variation of the gain error across devices and across channels within a device is specified separately.

Offset Error – The offset error is the difference, given in number of LSBs, between the ADC's actual average idle channel output code and the ideal average idle channel output code. This quantity is often mapped into mV.

Temperature Drift – The temperature drift coefficient (with respect to gain error and offset error) specifies the change per degree Celsius of the parameter from T_{MIN} to T_{MAX} . It is calculated by dividing the maximum deviation of the parameter across the T_{MIN} to T_{MAX} range by the difference $T_{MAX} - T_{MIN}$.

Signal-to-Noise Ratio – SNR is the ratio of the power of the fundamental (P_S) to the noise floor power (P_N), excluding the power at DC and the first nine harmonics.

$$SNR = 10 \log_{10} \frac{P_S}{P_N} \quad (6)$$

SNR is either given in units of dBc (dB to carrier) when the absolute power of the fundamental is used as the reference, or dBFS (dB to full scale) when the power of the fundamental is extrapolated to the converter's full-scale range.

Signal-to-Noise and Distortion (SINAD) – SINAD is the ratio of the power of the fundamental (P_S) to the power of all the other spectral components including noise (P_N) and distortion (P_D), but excluding dc.

$$SINAD = 10 \log_{10} \frac{P_S}{P_N + P_D} \quad (7)$$

SINAD is either given in units of dBc (dB to carrier) when the absolute power of the fundamental is used as the reference, or dBFS (dB to full scale) when the power of the fundamental is extrapolated to the converter's full-scale range.

Effective Number of Bits (ENOB) – The ENOB is a measure of a converter's performance as compared to the theoretical limit based on quantization noise.

$$ENOB = \frac{SINAD - 1.76}{6.02} \quad (8)$$

Total Harmonic Distortion (THD) – THD is the ratio of the power of the fundamental (P_S) to the power of the first nine harmonics (PD).

$$\text{THD} = 10\text{Log}_{10} \frac{P_S}{PD} \quad (9)$$

THD is typically given in units of dBc (dB to carrier).

Spurious-Free Dynamic Range (SFDR) – The ratio of the power of the fundamental to the highest other spectral component (either spur or harmonic). SFDR is typically given in units of dBc (dB to carrier).

Two-Tone Intermodulation Distortion – IMD3 is the ratio of the power of the fundamental (at frequencies f_1 and f_2) to the power of the worst spectral component at either frequency $2f_1-f_2$ or $2f_2-f_1$. IMD3 is either given in units of dBc (dB to carrier) when the absolute power of the fundamental is used as the reference, or dBFS (dB to full scale) when the power of the fundamental is extrapolated to the converter's full-scale range.

DC Power Supply Rejection Ratio (DC PSRR) – The DC PSRR is the ratio of the change in offset error to a change in analog supply voltage. The DC PSRR is typically given in units of mV/V.

AC Power Supply Rejection Ratio (AC PSRR) – AC PSRR is the measure of rejection of variations in the supply voltage by the ADC. If ΔV_{sup} is the change in supply voltage and ΔV_{out} is the resultant change of the ADC output code (referred to the input), then

$$\text{PSRR} = 20\text{Log}_{10} \frac{\Delta V_{\text{out}}}{\Delta V_{\text{sup}}}, \text{ expressed in dBc} \quad (10)$$

Voltage Overload Recovery – The number of clock cycles taken to recover to less than 1% error after an overload on the analog inputs. This is tested by separately applying a sine wave signal with 6 dB positive and negative overload. The deviation of the first few samples after the overload (from their expected values) is noted.

Common Mode Rejection Ratio (CMRR) – CMRR is the measure of rejection of variation in the analog input common-mode by the ADC. If $\Delta V_{\text{cm_in}}$ is the change in the common-mode voltage of the input pins and ΔV_{out} is the resultant change of the ADC output code (referred to the input), then

$$\text{CMRR} = 20\text{Log}_{10} \frac{\Delta V_{\text{out}}}{\Delta V_{\text{cm_in}}}, \text{ expressed in dBc} \quad (11)$$

Cross-Talk (Only for Multi-Channel ADC)– This is a measure of the internal coupling of a signal from adjacent channel into the channel of interest. It is specified separately for coupling from the immediate neighboring channel (near-channel) and for coupling from channel across the package (far-channel). It is usually measured by applying a full-scale signal in the adjacent channel. Cross-talk is the ratio of the power of the coupling signal (as measured at the output of the channel of interest) to the power of the signal applied at the adjacent channel input. It is typically expressed in dBc.

REVISION HISTORY

Changes from Original (January 2008) to Revision A	Page
• Changed Figure 3 , LVDS Mode Timing.	10
Changes from Revision A (February 2008) to Revision B	
• Changed the Functional Block Diagram	2
• Changed Figure 1 , Digital Processing Block Diagram.	3
• Changed SNRBoost disabled min values	7
• Added section: Serial Register Readout (only when CMOS interface is used).	15
• Changed Table 7	18
• Changed DO in Table 8	19
• Changed CMOS Interface, pin 56 From: NC To: SDOOUT	25
• Changed Figure 50 , Digital Processing Block Diagram	48
Changes from Revision B (May 2008) to Revision C	
• Added paragraph - When <SERIAL READOUT> is disabled, the SDOOUT pin is forced low or high by the device (and not put in high-impedance). If serial readout is not used, the SDOOUT pin must be floated.	15
• Changed the SDOOUT text in Figure 7(A)	16
• Added text (Table 8) - SDOOUT pin is forced low or high by the device (and not put in high-impedance state)	19
• Added text to the SDOOUT pin description - When <SERIAL READOUT> = 0, SDOOUT pin is forced low or high by... ..	26
Changes from Revision C (July 2009) to Revision D	
• Added paragraph - This disables any further writes into the registers, EXCEPT the register at address 0. Note that the <SERIAL READOUT> bit is also located in register 0. The device can exit readout mode by writing <SERIAL READOUT> to 0. Also, only the	15
• Changed paragraph - To exit the serial readout mode, reset register bit <SERIAL READOUT> =0, which enables writes into all registers of the device.	15
• Changed Normalized Corner Frequencies changed to fix error with respect to the mapping between the SNRBoost coefficient value and normalized corner frequency (f/fs).	38
• Changed values for Normalized Corner Frequency1, 2, and center frequency	39
Changes from Revision D (July 2009) to Revision E	
• Changed pins 29, 30 and 19, 20 in CMOS interface pinout	25
• Changed pins 29, 30 in Pin Assignments (CMOS interface)	26
• Changed pins 19, 20 in Pin Assignments (CMOS interface)	26
• Changed pins 29, 30 and 19, 20 in LVDS interface pinout	27
• Changed pins 29, 30 in Pin Assignments (LVDS interface)	27
• Changed pins 19, 20 in Pin Assignments (LVDS interface)	27

PACKAGING INFORMATION

Orderable Device	Status (1)	Package Type	Package Drawing	Pins	Package Qty	Eco Plan (2)	Lead/Ball Finish (6)	MSL Peak Temp (3)	Op Temp (°C)	Device Marking (4/5)	Samples
ADS62C15IRGCR	ACTIVE	VQFN	RGC	64	2000	Green (RoHS & no Sb/Br)	CU NIPDAU	Level-3-260C-168 HR	-40 to 85	AZ62C15	Samples
ADS62C15IRGCT	ACTIVE	VQFN	RGC	64	250	Green (RoHS & no Sb/Br)	CU NIPDAU	Level-3-260C-168 HR	-40 to 85	AZ62C15	Samples
ADS62C15IRGCTG4	ACTIVE	VQFN	RGC	64	250	Green (RoHS & no Sb/Br)	CU NIPDAU	Level-3-260C-168 HR	-40 to 85	AZ62C15	Samples

(1) The marketing status values are defined as follows:

ACTIVE: Product device recommended for new designs.

LIFEBUY: TI has announced that the device will be discontinued, and a lifetime-buy period is in effect.

NRND: Not recommended for new designs. Device is in production to support existing customers, but TI does not recommend using this part in a new design.

PREVIEW: Device has been announced but is not in production. Samples may or may not be available.

OBSOLETE: TI has discontinued the production of the device.

(2) Eco Plan - The planned eco-friendly classification: Pb-Free (RoHS), Pb-Free (RoHS Exempt), or Green (RoHS & no Sb/Br) - please check <http://www.ti.com/productcontent> for the latest availability information and additional product content details.

TBD: The Pb-Free/Green conversion plan has not been defined.

Pb-Free (RoHS): TI's terms "Lead-Free" or "Pb-Free" mean semiconductor products that are compatible with the current RoHS requirements for all 6 substances, including the requirement that lead not exceed 0.1% by weight in homogeneous materials. Where designed to be soldered at high temperatures, TI Pb-Free products are suitable for use in specified lead-free processes.

Pb-Free (RoHS Exempt): This component has a RoHS exemption for either 1) lead-based flip-chip solder bumps used between the die and package, or 2) lead-based die adhesive used between the die and leadframe. The component is otherwise considered Pb-Free (RoHS compatible) as defined above.

Green (RoHS & no Sb/Br): TI defines "Green" to mean Pb-Free (RoHS compatible), and free of Bromine (Br) and Antimony (Sb) based flame retardants (Br or Sb do not exceed 0.1% by weight in homogeneous material)

(3) MSL, Peak Temp. - The Moisture Sensitivity Level rating according to the JEDEC industry standard classifications, and peak solder temperature.

(4) There may be additional marking, which relates to the logo, the lot trace code information, or the environmental category on the device.

(5) Multiple Device Markings will be inside parentheses. Only one Device Marking contained in parentheses and separated by a "~" will appear on a device. If a line is indented then it is a continuation of the previous line and the two combined represent the entire Device Marking for that device.

(6) Lead/Ball Finish - Orderable Devices may have multiple material finish options. Finish options are separated by a vertical ruled line. Lead/Ball Finish values may wrap to two lines if the finish value exceeds the maximum column width.

Important Information and Disclaimer: The information provided on this page represents TI's knowledge and belief as of the date that it is provided. TI bases its knowledge and belief on information provided by third parties, and makes no representation or warranty as to the accuracy of such information. Efforts are underway to better integrate information from third parties. TI has taken and

continues to take reasonable steps to provide representative and accurate information but may not have conducted destructive testing or chemical analysis on incoming materials and chemicals. TI and TI suppliers consider certain information to be proprietary, and thus CAS numbers and other limited information may not be available for release.

In no event shall TI's liability arising out of such information exceed the total purchase price of the TI part(s) at issue in this document sold by TI to Customer on an annual basis.

TAPE AND REEL INFORMATION



QUADRANT ASSIGNMENTS FOR PIN 1 ORIENTATION IN TAPE



*All dimensions are nominal

Device	Package Type	Package Drawing	Pins	SPQ	Reel Diameter (mm)	Reel Width W1 (mm)	A0 (mm)	B0 (mm)	K0 (mm)	P1 (mm)	W (mm)	Pin1 Quadrant
ADS62C15IRGCR	VQFN	RGC	64	2000	330.0	16.4	9.3	9.3	1.5	12.0	16.0	Q2
ADS62C15IRGCT	VQFN	RGC	64	250	180.0	16.4	9.3	9.3	1.5	12.0	16.0	Q2

TAPE AND REEL BOX DIMENSIONS

*All dimensions are nominal

Device	Package Type	Package Drawing	Pins	SPQ	Length (mm)	Width (mm)	Height (mm)
ADS62C15IRGCR	VQFN	RGC	64	2000	350.0	350.0	43.0
ADS62C15IRGCT	VQFN	RGC	64	250	213.0	191.0	55.0

GENERIC PACKAGE VIEW

RGC 64

VQFN - 1 mm max height

9 x 9, 0.5 mm pitch

PLASTIC QUAD FLATPACK - NO LEAD

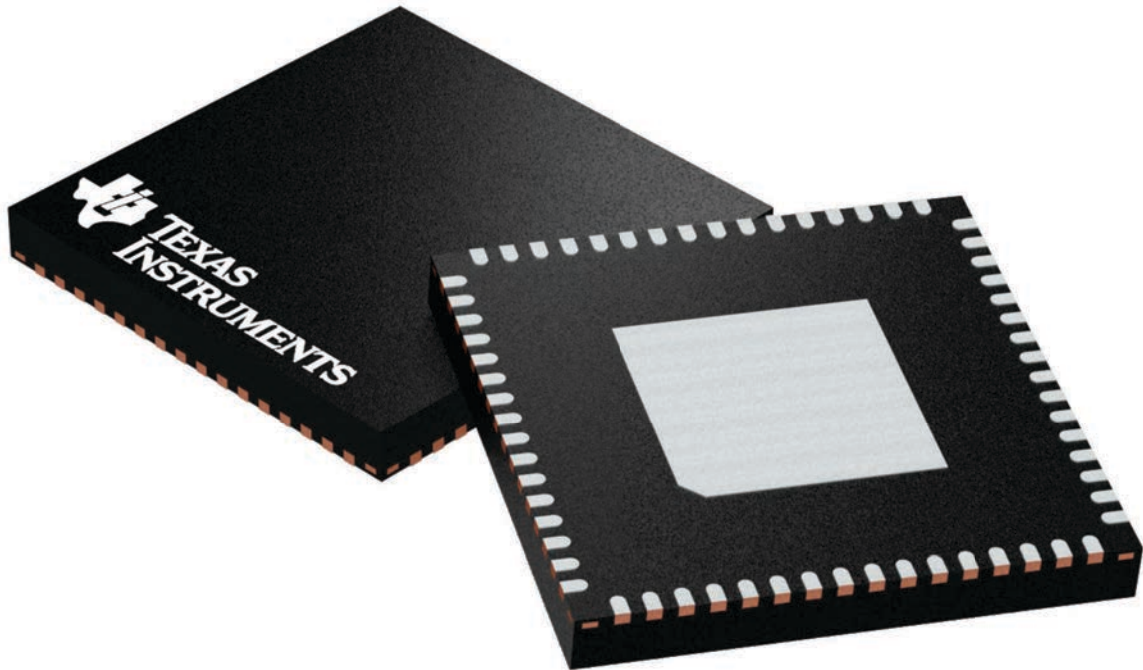

Images above are just a representation of the package family, actual package may vary.
Refer to the product data sheet for package details.

4224597/A

RGC0064H

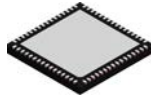

PACKAGE OUTLINE

VQFN - 1 mm max height

PLASTIC QUAD FLATPACK - NO LEAD

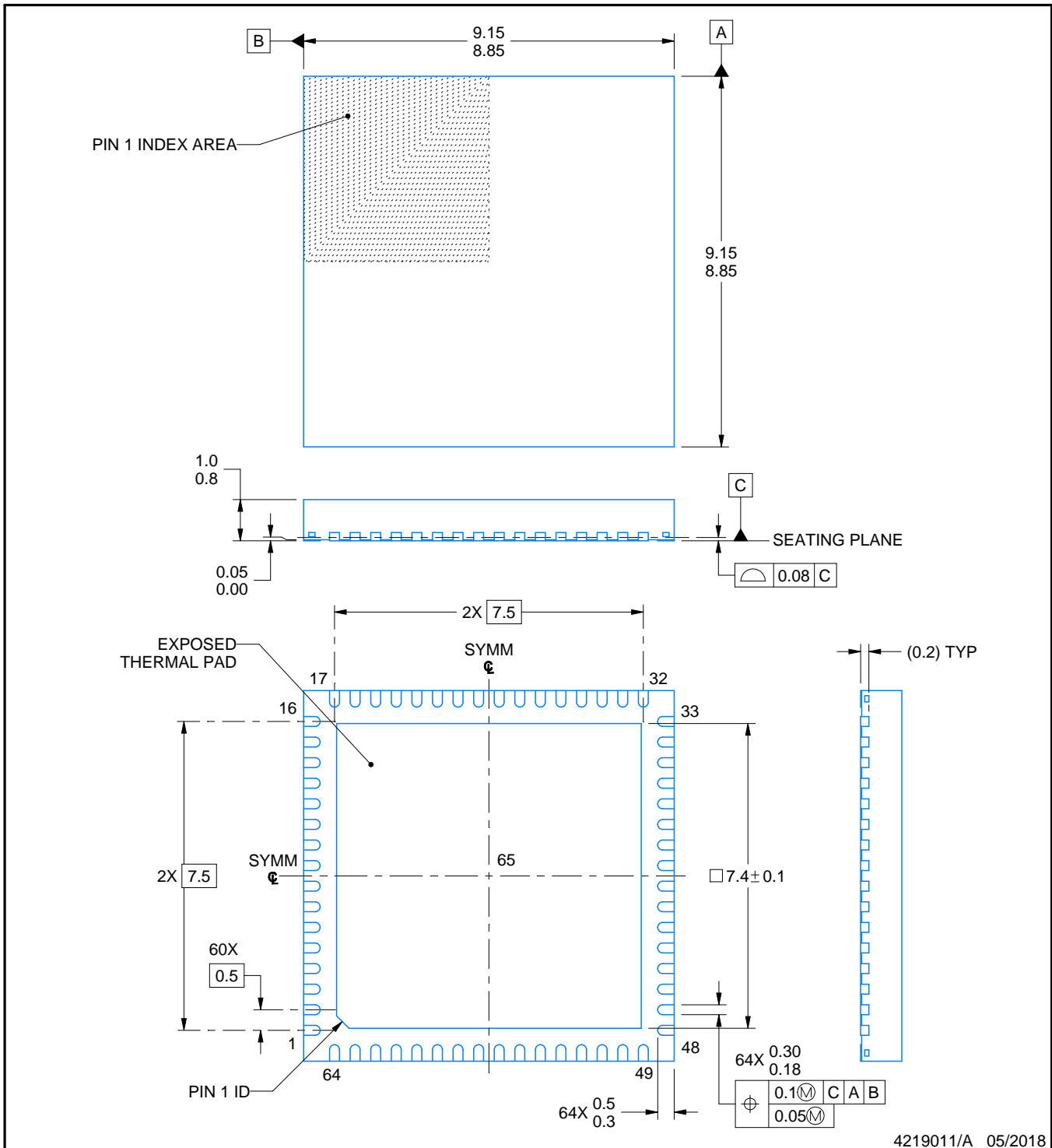

NOTES:

1. All linear dimensions are in millimeters. Any dimensions in parenthesis are for reference only. Dimensioning and tolerancing per ASME Y14.5M.
2. This drawing is subject to change without notice.
3. The package thermal pad must be soldered to the printed circuit board for thermal and mechanical performance.

EXAMPLE BOARD LAYOUT

RGC0064H

VQFN - 1 mm max height

PLASTIC QUAD FLATPACK - NO LEAD

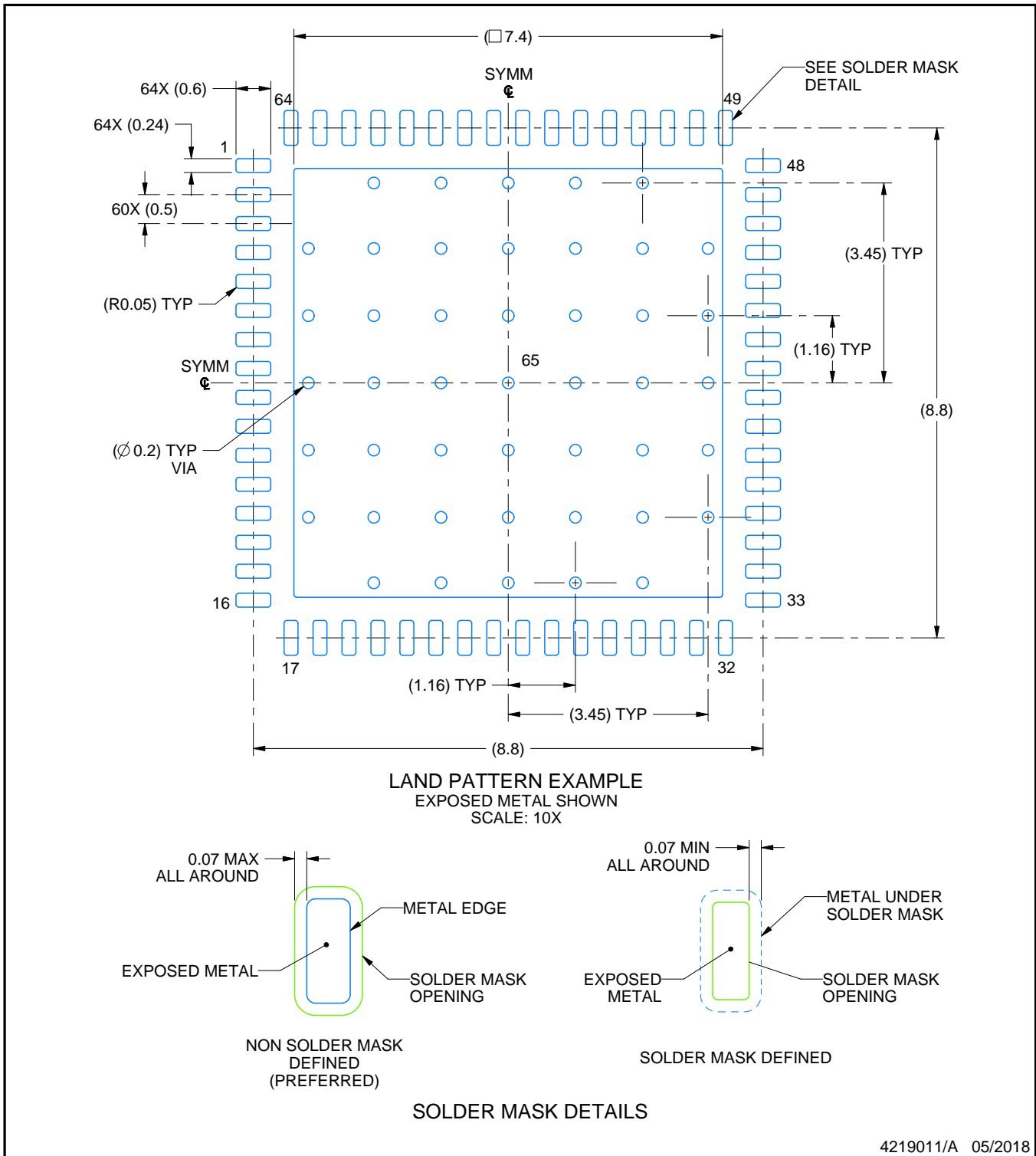

4219011/A 05/2018

NOTES: (continued)

- This package is designed to be soldered to a thermal pad on the board. For more information, see Texas Instruments literature number SLUA271 (www.ti.com/lit/sluea271).
- Vias are optional depending on application, refer to device data sheet. If any vias are implemented, refer to their locations shown on this view. It is recommended that vias under paste be filled, plugged or tented.

EXAMPLE STENCIL DESIGN

RGC0064H

VQFN - 1 mm max height

PLASTIC QUAD FLATPACK - NO LEAD

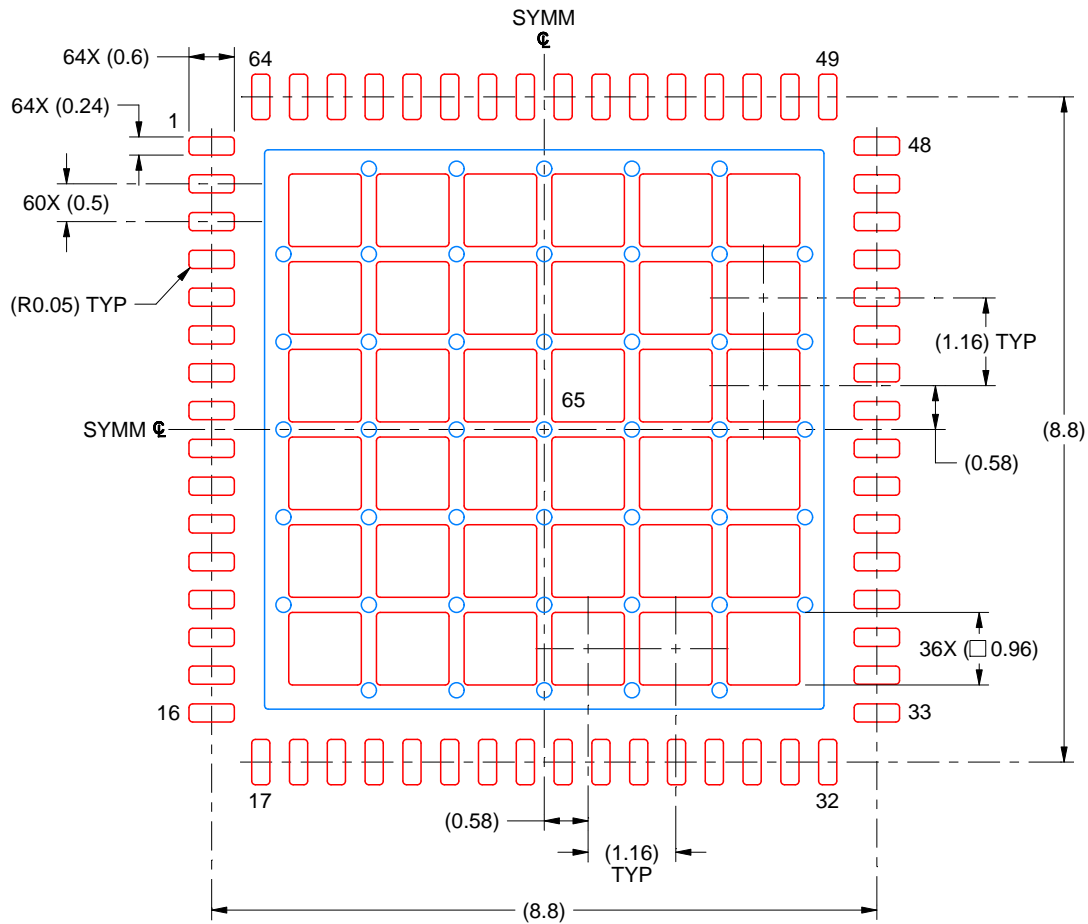

SOLDER PASTE EXAMPLE
 BASED ON 0.125 MM THICK STENCIL
 SCALE: 10X

EXPOSED PAD 65
 61% PRINTED SOLDER COVERAGE BY AREA UNDER PACKAGE

4219011/A 05/2018

NOTES: (continued)

6. Laser cutting apertures with trapezoidal walls and rounded corners may offer better paste release. IPC-7525 may have alternate design recommendations.

IMPORTANT NOTICE AND DISCLAIMER

TI PROVIDES TECHNICAL AND RELIABILITY DATA (INCLUDING DATASHEETS), DESIGN RESOURCES (INCLUDING REFERENCE DESIGNS), APPLICATION OR OTHER DESIGN ADVICE, WEB TOOLS, SAFETY INFORMATION, AND OTHER RESOURCES "AS IS" AND WITH ALL FAULTS, AND DISCLAIMS ALL WARRANTIES, EXPRESS AND IMPLIED, INCLUDING WITHOUT LIMITATION ANY IMPLIED WARRANTIES OF MERCHANTABILITY, FITNESS FOR A PARTICULAR PURPOSE OR NON-INFRINGEMENT OF THIRD PARTY INTELLECTUAL PROPERTY RIGHTS.

These resources are intended for skilled developers designing with TI products. You are solely responsible for (1) selecting the appropriate TI products for your application, (2) designing, validating and testing your application, and (3) ensuring your application meets applicable standards, and any other safety, security, or other requirements. These resources are subject to change without notice. TI grants you permission to use these resources only for development of an application that uses the TI products described in the resource. Other reproduction and display of these resources is prohibited. No license is granted to any other TI intellectual property right or to any third party intellectual property right. TI disclaims responsibility for, and you will fully indemnify TI and its representatives against, any claims, damages, costs, losses, and liabilities arising out of your use of these resources.

TI's products are provided subject to TI's Terms of Sale (www.ti.com/legal/termsofsale.html) or other applicable terms available either on ti.com or provided in conjunction with such TI products. TI's provision of these resources does not expand or otherwise alter TI's applicable warranties or warranty disclaimers for TI products.

Mailing Address: Texas Instruments, Post Office Box 655303, Dallas, Texas 75265
Copyright © 2019, Texas Instruments Incorporated

Looking for pricing, stock, or lifecycle information?

Click below to explore more details on WIN SOURCE:

 [View ADS62C15IRGCT](#) on WIN SOURCE

 [Texas Instruments](#) Information

Optimize Your Supply Chain with WIN SOURCE Solutions

-  Global Sourcing Solution
-  Obsolete Management
-  Cost Control Management
-  Shortage Management
-  Alternative Solution
-  Excess Inventory Management