



**THE DATASHEET OF
LM2717MTX-ADJ/NOPB**



LM2717-ADJ Dual Step-Down DC/DC Converter

Check for Samples: [LM2717-ADJ](#)

FEATURES

- Adjustable Buck Converter with a 2.2A, 0.16Ω, Internal Switch (Buck 1)
- Adjustable Buck Converter with a 3.2A, 0.16Ω, Internal Switch (Buck 2)
- Operating Input Voltage Range of 4V to 20V
- Input Undervoltage Protection
- 300kHz to 600kHz Pin Adjustable Operating Frequency
- Over Temperature Protection
- Small 24-Lead TSSOP Package

APPLICATIONS

- TFT-LCD Displays
- Handheld Devices
- Portable Applications
- Laptop Computers
- Automotive Applications

DESCRIPTION

The LM2717-ADJ is composed of two PWM DC/DC buck (step-down) converters. Both converters are used to generate an adjustable output voltage as low as 1.267V. Both also feature low $R_{\text{DS(ON)}}$ (0.16Ω) internal switches for maximum efficiency. Operating frequency can be adjusted anywhere between 300kHz and 600kHz allowing the use of small external components. External soft-start pins for each converter enables the user to tailor the soft-start times to a specific application. Each converter may also be shut down independently with its own shutdown pin. The LM2717-ADJ is available in a low profile 24-lead TSSOP package ensuring a low profile overall solution.



Please be aware that an important notice concerning availability, standard warranty, and use in critical applications of Texas Instruments semiconductor products and disclaimers thereto appears at the end of this data sheet.

All trademarks are the property of their respective owners.

PRODUCTION DATA information is current as of publication date. Products conform to specifications per the terms of the Texas Instruments standard warranty. Production processing does not necessarily include testing of all parameters.

Copyright © 2005–2013, Texas Instruments Incorporated

Typical Application Circuit

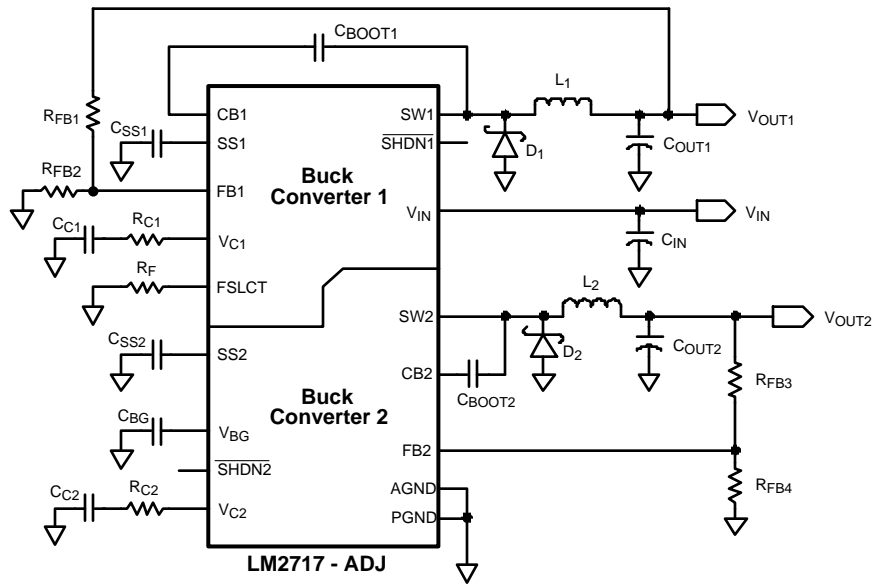

Connection Diagram

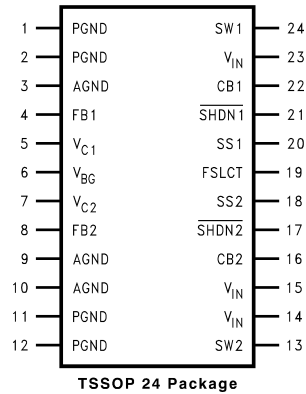
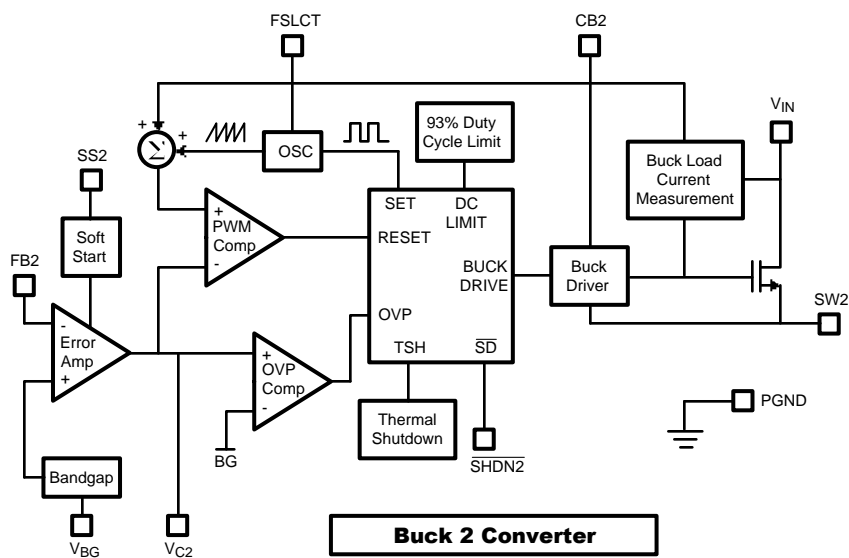
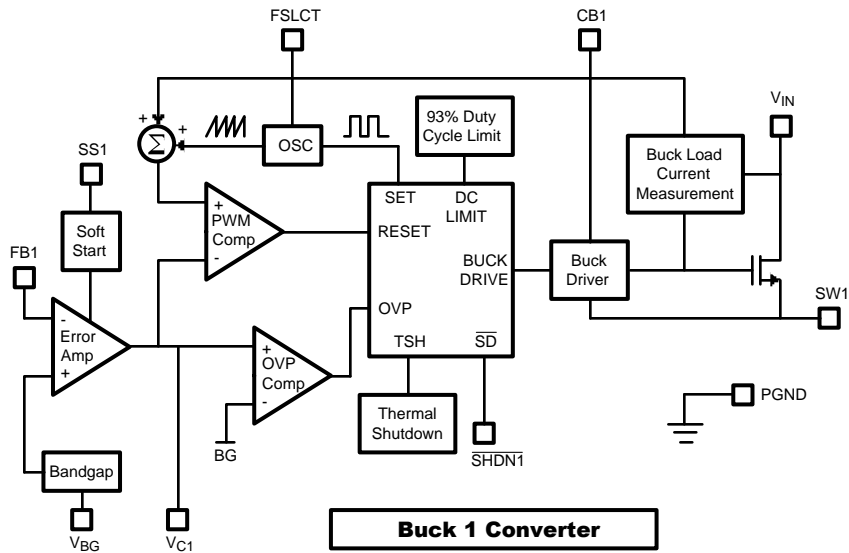

Figure 1. 24-Lead TSSOP Top View

PIN DESCRIPTIONS

Pin	Name	Function
1	PGND	Power ground. PGND and AGND pins must be connected together directly at the part.
2	PGND	Power ground. PGND and AGND pins must be connected together directly at the part.
3	AGND	Analog ground. PGND and AGND pins must be connected together directly at the part.
4	FB1	Buck 1 output voltage feedback input.
5	V _{C1}	Buck 1 compensation network connection. Connected to the output of the voltage error amplifier.
6	V _{BG}	Bandgap connection.
7	V _{C2}	Buck 2 compensation network connection. Connected to the output of the voltage error amplifier.
8	FB2	Buck 2 output voltage feedback input.
9	AGND	Analog ground. PGND and AGND pins must be connected together directly at the part.
10	AGND	Analog ground. PGND and AGND pins must be connected together directly at the part.
11	PGND	Power ground. PGND and AGND pins must be connected together directly at the part.
12	PGND	Power ground. PGND and AGND pins must be connected together directly at the part.
13	SW2	Buck 2 power switch input. Switch connected between V _{IN} pins and SW2 pin.
14	V _{IN}	Analog power input. All V _{IN} pins are internally connected and should be connected together directly at the part.
15	V _{IN}	Analog power input. All V _{IN} pins are internally connected and should be connected together directly at the part.
16	CB2	Buck 2 converter bootstrap capacitor connection.
17	$\overline{\text{SHDN2}}$	Shutdown pin for Buck 2 converter. Active low.
18	SS2	Buck 2 soft start pin.
19	FSLCT	Switching frequency select input. Use a resistor to set the frequency anywhere between 300kHz and 600kHz.
20	SS1	Buck 1 soft start pin.
21	$\overline{\text{SHDN1}}$	Shutdown pin for Buck 1 converter. Active low.
22	CB1	Buck 1 converter bootstrap capacitor connection.
23	V _{IN}	Analog power input. All V _{IN} pins are internally connected and should be connected together directly at the part.
24	SW1	Buck 1 power switch input. Switch connected between V _{IN} pins and SW1 pin.

Block Diagram





These devices have limited built-in ESD protection. The leads should be shorted together or the device placed in conductive foam during storage or handling to prevent electrostatic damage to the MOS gates.

Absolute Maximum Ratings ⁽¹⁾

V_{IN}		-0.3V to 22V
SW1 Voltage		-0.3V to 22V
SW2 Voltage		-0.3V to 22V
FB1, FB2 Voltages		-0.3V to 7V
CB1, CB2 Voltages		-0.3V to $V_{IN}+7V$ ($V_{IN}=V_{SW}$)
V_{C1} Voltage		$1.75V \leq V_{C1} \leq 2.25V$
V_{C2} Voltage		$0.965V \leq V_{C2} \leq 1.565V$
$\overline{SHDN1}$ Voltage		-0.3V to 7.5V
$\overline{SHDN2}$ Voltage		-0.3V to 7.5V
SS1 Voltage		-0.3V to 2.1V
SS2 Voltage		-0.3V to 2.1V
FSLCT Voltage		AGND to 5V
Maximum Junction Temperature		150°C
Power Dissipation ⁽²⁾		Internally Limited
Lead Temperature		300°C
Vapor Phase (60 sec.)		215°C
Infrared (15 sec.)		220°C
ESD Susceptibility ⁽³⁾	Human Body Model	2kV

- (1) Absolute maximum ratings are limits beyond which damage to the device may occur. Operating Ratings are conditions for which the device is intended to be functional, but device parameter specifications may not be ensured. For ensured specifications and test conditions, see the Electrical Characteristics table.
- (2) The maximum allowable power dissipation is a function of the maximum junction temperature, $T_J(\text{MAX})$, the junction-to-ambient thermal resistance, θ_{JA} , and the ambient temperature, T_A . See the Electrical Characteristics table for the thermal resistance. The maximum allowable power dissipation at any ambient temperature is calculated using: $P_D(\text{MAX}) = (T_J(\text{MAX}) - T_A)/\theta_{JA}$. Exceeding the maximum allowable power dissipation will cause excessive die temperature, and the regulator will go into thermal shutdown.
- (3) The human body model is a 100 pF capacitor discharged through a 1.5kΩ resistor into each pin.

Operating Conditions

Operating Junction Temperature Range ⁽¹⁾		-40°C to +125°C
Storage Temperature		-65°C to +150°C
Supply Voltage		4V to 20V
SW1 Voltage		20V
SW2 Voltage		20V
Switching Frequency		300kHz to 600kHz

- (1) All limits specified at room temperature (standard typeface) and at temperature extremes (bold typeface). All room temperature limits are 100% tested or specified through statistical analysis. All limits at temperature extremes are specified via correlation using standard Statistical Quality Control (SQC) methods. All limits are used to calculate Average Outgoing Quality Level (AOQL).

Electrical Characteristics

Specifications in standard type face are for $T_J = 25^\circ\text{C}$ and those with **boldface type** apply over the full **Operating Temperature Range** ($T_J = -40^\circ\text{C}$ to $+125^\circ\text{C}$). $V_{IN} = 5\text{V}$, $I_L = 0\text{A}$, and $F_{SW} = 300\text{kHz}$ unless otherwise specified.

Symbol	Parameter	Conditions	Min (1)	Typ (2)	Max (1)	Units
I_Q	Total Quiescent Current (both switchers)	Not Switching		2.7	6	mA
		Switching, switch open		6	12	mA
		$V_{SHDN} = 0\text{V}$		9	27	μA
V_{BG}	Bandgap Voltage		1.248 1.230	1.267	1.294 1.299	V
$\%V_{BG}/\Delta V_{IN}$	Bandgap Voltage Line Regulation		-0.01		0.01 0.125	$\%/V$
V_{FB1}	Buck 1 Feedback Voltage		1.236 1.214	1.258	1.286 1.288	V
V_{FB2}	Buck 2 Feedback Voltage		1.236 1.214	1.258	1.286 1.288	V
$I_{CL1}^{(3)}$	Buck 1 Switch Current Limit	$V_{IN} = 8\text{V}^{(4)}$		2.2		A
		$V_{IN} = 12\text{V}$, $V_{OUT} = 3.3\text{V}$	1.4	1.65	2.0	
$I_{CL2}^{(3)}$	Buck 2 Switch Current Limit	$V_{IN} = 8\text{V}^{(4)}$		3.2		A
		$V_{IN} = 12\text{V}$, $V_{OUT} = 5\text{V}$	2.6	3.05	3.5	
I_{B1}	Buck 1 FB Pin Bias Current (5)	$V_{IN} = 20\text{V}$		70	400	nA
I_{B2}	Buck 2 FB Pin Bias Current (5)	$V_{IN} = 20\text{V}$		65	400	nA
V_{IN}	Input Voltage Range		4		20	V
g_{m1}	Buck 1 Error Amp Transconductance	$\Delta I = 20\mu\text{A}$		1340		μmho
g_{m2}	Buck 2 Error Amp Transconductance	$\Delta I = 20\mu\text{A}$		1360		μmho
A_{V1}	Buck 1 Error Amp Voltage Gain			134		V/V
A_{V2}	Buck 2 Error Amp Voltage Gain			136		V/V
D_{MAX}	Maximum Duty Cycle		89	93		%
F_{SW}	Switching Frequency	$R_F = 46.4\text{k}$	240	300	360	kHz
		$R_F = 22.6\text{k}$	480	600	720	
I_{SHDN1}	Buck 1 Shutdown Pin Current	$0\text{V} < V_{SHDN1} < 7.5\text{V}$	-5		5	μA
I_{SHDN2}	Buck 2 Shutdown Pin Current	$0\text{V} < V_{SHDN2} < 7.5\text{V}$	-5		5	μA
I_{L1}	Buck 1 Switch Leakage Current	$V_{IN} = 20\text{V}$		0.01	5	μA
I_{L2}	Buck 2 Switch Leakage Current	$V_{IN} = 20\text{V}$		0.01	5	μA
R_{DSON1}	Buck 1 Switch $R_{DSON}^{(6)}$	$I_{SW} = 100\text{mA}$		160	180 300	m Ω
R_{DSON2}	Buck 2 Switch $R_{DSON}^{(6)}$	$I_{SW} = 100\text{mA}$		160	180 300	
Th_{SHDN1}	Buck 1 $\overline{\text{SHDN}}$ Threshold	Output High	1.8	1.36		V
		Output Low		1.33	0.7	

- (1) All limits specified at room temperature (standard typeface) and at temperature extremes (bold typeface). All room temperature limits are 100% tested or specified through statistical analysis. All limits at temperature extremes are specified via correlation using standard Statistical Quality Control (SQC) methods. All limits are used to calculate Average Outgoing Quality Level (AOQL).
- (2) Typical numbers are at 25°C and represent the most likely norm.
- (3) Duty cycle affects current limit due to ramp generator.
- (4) Current limit at 0% duty cycle. See **TYPICAL PERFORMANCE** section for Switch Current Limit vs. Input Voltage.
- (5) Bias current flows into FB pin.
- (6) Includes the bond wires and package leads, R_{DSON} from V_{IN} pin(s) to SW pin.

Electrical Characteristics (continued)

Specifications in standard type face are for $T_J = 25^\circ\text{C}$ and those with **boldface type** apply over the full **Operating Temperature Range** ($T_J = -40^\circ\text{C}$ to $+125^\circ\text{C}$). $V_{IN} = 5\text{V}$, $I_L = 0\text{A}$, and $F_{SW} = 300\text{kHz}$ unless otherwise specified.

Symbol	Parameter	Conditions	Min (1)	Typ (2)	Max (1)	Units
Th _{SHDN2}	Buck 2 SHDN Threshold	Output High	1.8	1.36		V
		Output Low		1.33	0.7	
I _{SS1}	Buck 1 Soft Start Pin Current		4	9	15	μA
I _{SS2}	Buck 2 Soft Start Pin Current		4	9	15	μA
UVP	On Threshold		4	3.8		V
	Off Threshold			3.6	3.3	
θ _{JA}	Thermal Resistance (7)	TSSOP, package only		115		°C/W

(7) Refer to the www.ti.com/packaging for more detailed thermal information and mounting techniques for the TSSOP package.

Typical Performance Characteristics

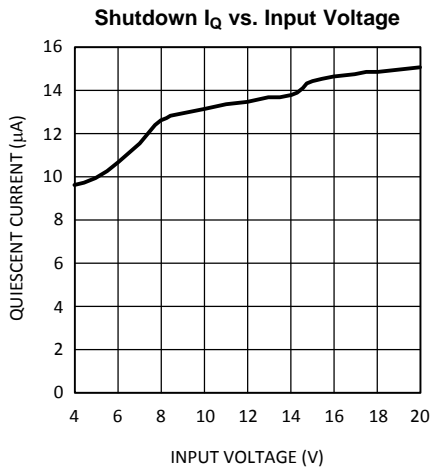

Figure 2.

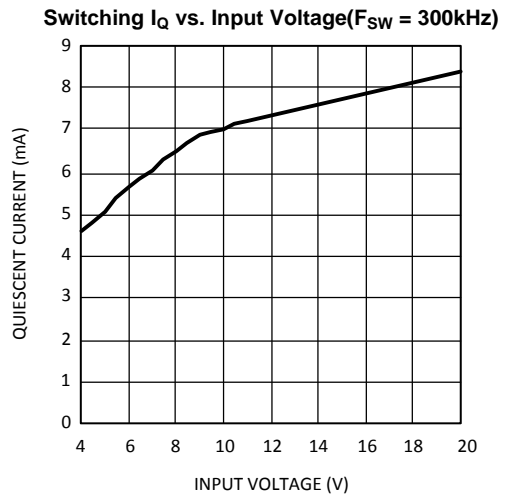

Figure 3.

Switching Frequency vs. Input Voltage ($F_{SW} = 300\text{kHz}$)

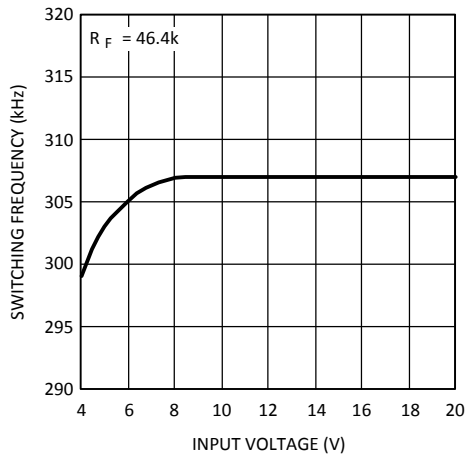

Figure 4.

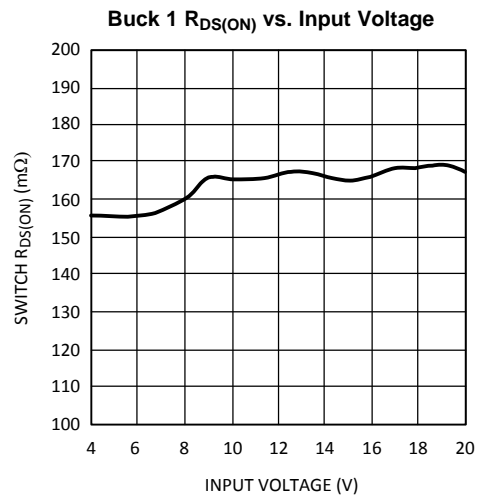

Figure 5.

Buck 2 $R_{DS(ON)}$ vs. Input Voltage

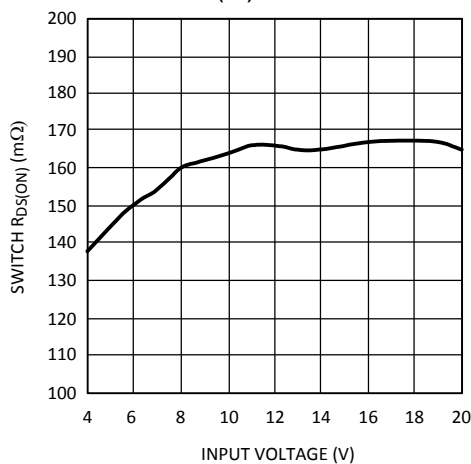

Figure 6.

Buck 1 Efficiency vs. Load Current ($V_{OUT} = 3.3\text{V}$)

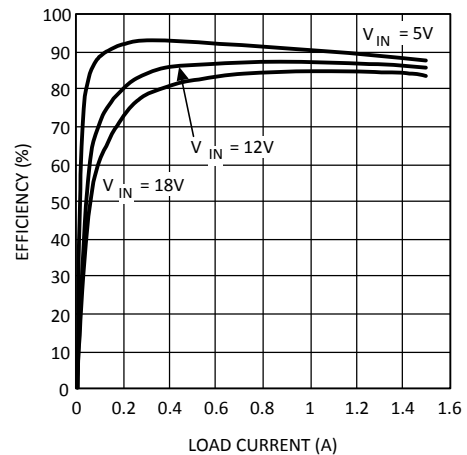

Figure 7.

Typical Performance Characteristics (continued)

Buck 2 Efficiency vs. Load Current ($V_{OUT} = 15V$)

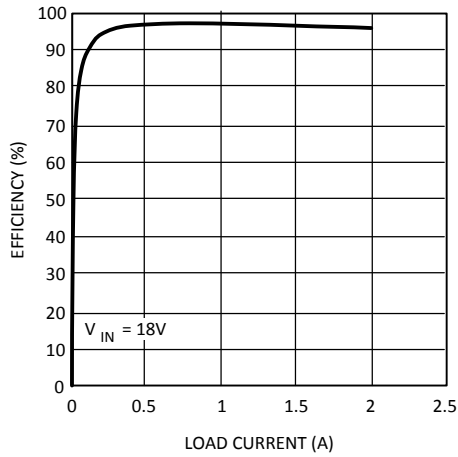

Figure 8.

Buck 2 Efficiency vs. Load Current ($V_{OUT} = 5V$)

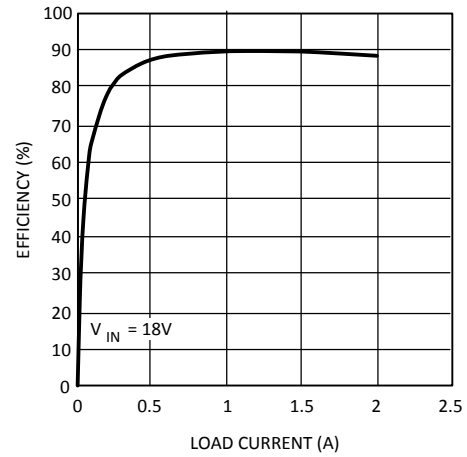

Figure 9.

Buck 1 Switch Current Limit vs. Input Voltage

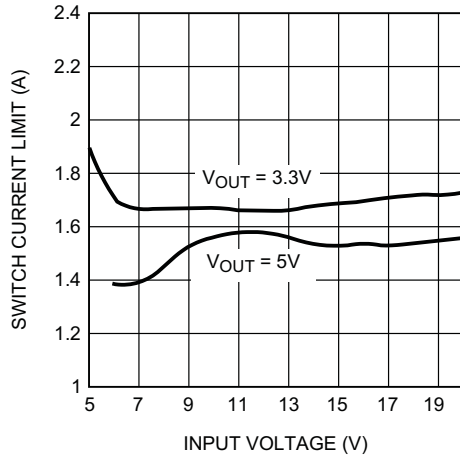

Figure 10.

Buck 2 Switch Current Limit vs. Input Voltage

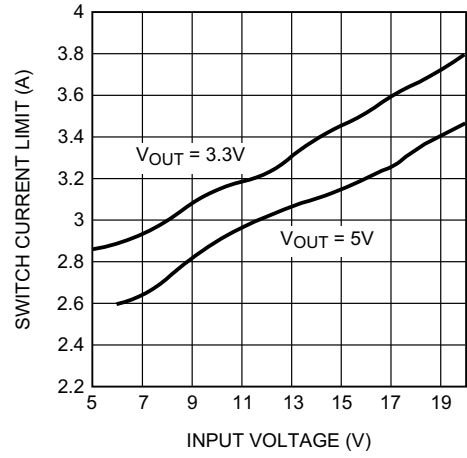

Figure 11.

Buck 1 Switch Current Limit vs. Temperature ($V_{IN} = 12V$)

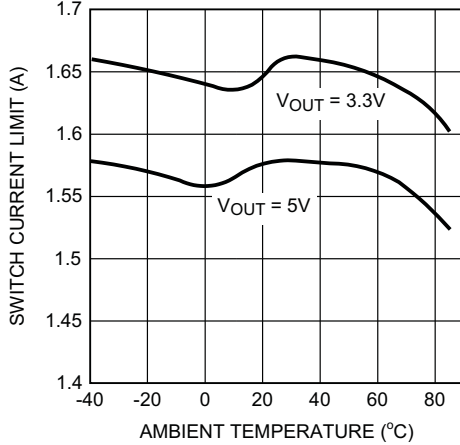

Figure 12.

Buck 2 Switch Current Limit vs. Temperature ($V_{IN} = 12V$)

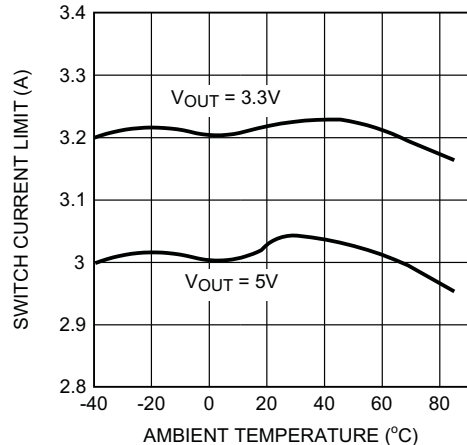

Figure 13.

Typical Performance Characteristics (continued)

Buck 1 Switch ON Resistance vs. Temperature

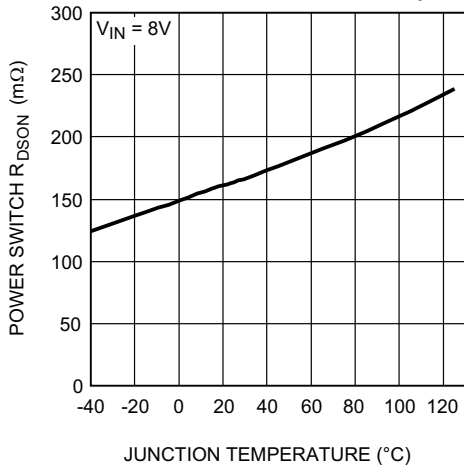

Figure 14.

Buck 2 Switch ON Resistance vs. Temperature

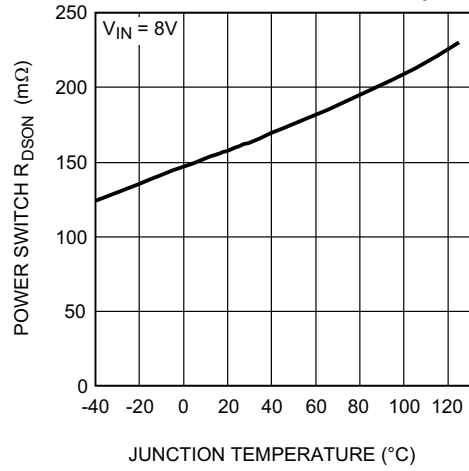

Figure 15.

Switching Frequency vs. R_F Resistance

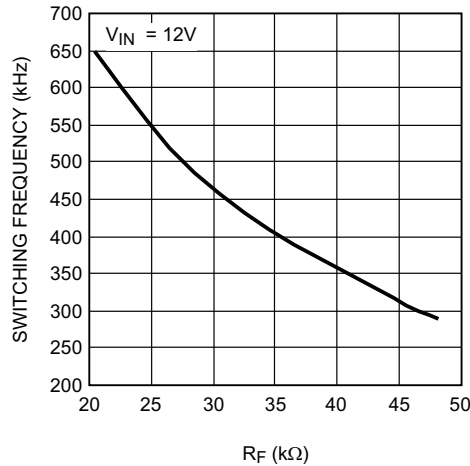

Figure 16.

BUCK OPERATION

PROTECTION (BOTH REGULATORS)

The LM2717-ADJ has dedicated protection circuitry running during normal operation to protect the IC. The Thermal Shutdown circuitry turns off the power devices when the die temperature reaches excessive levels. The UVP comparator protects the power devices during supply power startup and shutdown to prevent operation at voltages less than the minimum input voltage. The OVP comparator is used to prevent the output voltage from rising at no loads allowing full PWM operation over all load conditions. The LM2717-ADJ also features a shutdown mode for each converter decreasing the supply current to approximately 10µA (both in shutdown mode).

CONTINUOUS CONDUCTION MODE

The LM2717-ADJ contains current-mode, PWM buck regulators. A buck regulator steps the input voltage down to a lower output voltage. In continuous conduction mode (when the inductor current never reaches zero at steady state), the buck regulator operates in two cycles. The power switch is connected between V_{IN} and SW1 and SW2.

In the first cycle of operation the transistor is closed and the diode is reverse biased. Energy is collected in the inductor and the load current is supplied by C_{OUT} and the rising current through the inductor.

During the second cycle the transistor is open and the diode is forward biased due to the fact that the inductor current cannot instantaneously change direction. The energy stored in the inductor is transferred to the load and output capacitor.

The ratio of these two cycles determines the output voltage. The output voltage is defined approximately as:

$$D = \frac{V_{OUT}}{V_{IN}}, D' = (1-D)$$

where

- where D is the duty cycle of the switch
- D and D' will be required for design calculation (1)

The LM2717-ADJ has a minimum switch ON time which corresponds to a minimum duty cycle of approximately 10% at 600kHz operation and approximately 5% at 300kHz operation. In the case of some high voltage differential applications (low duty cycle operation) this minimum duty cycle may be exceeded causing the feedback pin over-voltage protection to trip as the output voltage rises. This will put the device into a PFM type operation which can cause an unpredictable frequency spectrum and may cause the average output voltage to rise slightly. If this is a concern the switching frequency may be lowered and/or a pre-load added to the output to keep the device full PWM operation. Note that the OVP function monitors the FB pin so it will not function if the feedback resistor is disconnected from the output. Due to slight differences between the two converters it is recommended that Buck 1 be used for the lower of the two output voltages for best operation.

DESIGN PROCEDURE

This section presents guidelines for selecting external components.

SETTING THE OUTPUT VOLTAGE

The output voltage is set using the feedback pin and a resistor divider connected to the output as shown in [Figure 20](#). The feedback pin voltage (V_{FB}) is 1.258V, so the ratio of the feedback resistors sets the output voltage according to the following equation:

$$R_{FB1(3)} = R_{FB2(4)} \times \frac{V_{OUT} - V_{FB1(2)}}{V_{FB1(2)}} \Omega \quad (2)$$

INPUT CAPACITOR

A low ESR aluminum, tantalum, or ceramic capacitor is needed between the input pin and power ground. This capacitor prevents large voltage transients from appearing at the input. The capacitor is selected based on the RMS current and voltage requirements. The RMS current is given by:

$$I_{RMS} = I_{OUT} \times \frac{\sqrt{V_{OUT}(V_{IN} - V_{OUT})}}{V_{IN}} \quad (3)$$

The RMS current reaches its maximum ($I_{OUT}/2$) when V_{IN} equals $2V_{OUT}$. This value should be calculated for both regulators and added to give a total RMS current rating. For an aluminum or ceramic capacitor, the voltage rating should be at least 25% higher than the maximum input voltage. If a tantalum capacitor is used, the voltage rating required is about twice the maximum input voltage. The tantalum capacitor should be surge current tested by the manufacturer to prevent being shorted by the inrush current. The minimum capacitor value should be $47\mu\text{F}$ for lower output load current applications and less dynamic (quickly changing) load conditions. For higher output current applications or dynamic load conditions a $68\mu\text{F}$ to $100\mu\text{F}$ low ESR capacitor is recommended. It is also recommended to put a small ceramic capacitor ($0.1\mu\text{F}$ to $4.7\mu\text{F}$) between the input pins and ground to reduce high frequency spikes.

INDUCTOR SELECTION

The most critical parameter for the inductor in a current mode switcher is the minimum value required for stable operation. To prevent subharmonic oscillations and achieve good phase margin a target minimum value for the inductor is:

$$L_{MIN} = \frac{(D-0.5+2/\pi)(V_{IN}-V_{OUT})R_{DS(ON)}}{(1-D)(0.164 \cdot F_{SW})} \quad (H) \quad (4)$$

Where V_{IN} is the minimum input voltage and $R_{DS(ON)}$ is the maximum switch ON resistance. For best stability the inductor should be in the range of $0.5L_{MIN}$ (absolute minimum) and $2L_{MIN}$. Using an inductor with a value less than $0.5L_{MIN}$ can cause subharmonic oscillations. The inductor should meet this minimum requirement at the peak inductor current expected for the application regardless of what the inductor ripple current and output ripple voltage requirements are. A value larger than $2L_{MIN}$ is acceptable if the ripple requirements of the application require it but it may reduce the phase margin and increase the difficulty in compensating the circuit.

The most important parameters for the inductor from an applications standpoint are the inductance, peak current and the DC resistance. The inductance is related to the peak-to-peak inductor ripple current, the input and the output voltages (for 300kHz operation):

$$L = \frac{(V_{IN} - V_{OUT})V_{OUT}}{V_{IN} \times I_{RIPPLE} \times 300 \text{ kHz}} \quad (5)$$

A higher value of ripple current reduces inductance, but increases the conduction loss, core loss, and current stress for the inductor and switch devices. It also requires a bigger output capacitor for the same output voltage ripple requirement. A reasonable value is setting the ripple current to be 30% of the DC output current. Since the ripple current increases with the input voltage, the maximum input voltage is always used to determine the inductance. The DC resistance of the inductor is a key parameter for the efficiency. Lower DC resistance is available with a bigger winding area. A good tradeoff between the efficiency and the core size is letting the inductor copper loss equal 2% of the output power.

OUTPUT CAPACITOR

The selection of C_{OUT} is driven by the maximum allowable output voltage ripple. The output ripple in the constant frequency, PWM mode is approximated by:

$$V_{RIPPLE} = I_{RIPPLE} \left(ESR + \frac{1}{8F_{S}C_{OUT}} \right) \quad (6)$$

The ESR term usually plays the dominant role in determining the voltage ripple. Low ESR ceramic, aluminum electrolytic, or tantalum capacitors (such as MuRata MLCC, Taiyo Yuden MLCC, Nichicon PL series, Sanyo OS-CON, Sprague 593D, 594D, AVX TPS, and CDE polymer aluminum) is recommended. An aluminum electrolytic capacitor is not recommended for temperatures below -25°C since its ESR rises dramatically at cold temperatures. Ceramic or tantalum capacitors have much better ESR specifications at cold temperature and is preferred for low temperature applications.

BOOTSTRAP CAPACITOR

A 4.7nF ceramic capacitor or larger is recommended for the bootstrap capacitor. For applications where the input voltage is less than twice the output voltage a larger capacitor is recommended, generally 0.1μF to 1μF to ensure plenty of gate drive for the internal switches and a consistently low $R_{\text{DS(on)}}$.

SOFT-START CAPACITOR (BOTH REGULATORS)

The LM2717-ADJ contains circuitry that can be used to limit the inrush current on start-up of the DC/DC switching regulators. This inrush current limiting circuitry serves as a soft-start. The external SS pins are used to tailor the soft-start for a specific application. A current (I_{SS}) charges the external soft-start capacitor, C_{SS} . The soft-start time can be estimated as:

$$T_{\text{SS}} = C_{\text{SS}} * 0.6V / I_{\text{SS}} \quad (7)$$

When programming the soft-start time use the equation given in the *Soft-Start Capacitor* section above. The soft-start function is used simply to limit inrush current to the device that could stress the input voltage supply. The soft-start time described above is the time it takes for the current limit to ramp to maximum value. When this function is used the current limit starts at a low value and increases to nominal at the set soft-start time. Under maximum load conditions the output voltage may rise at the same rate as the soft-start, however at light or no load conditions the output voltage will rise much faster as the switch will not need to conduct much current to charge the output capacitor.

SHUTDOWN OPERATION (BOTH REGULATORS)

The shutdown pins of the LM2717-ADJ are designed so that they may be controlled using 1.8V or higher logic signals. If the shutdown function is not to be used the pin may be left open. The maximum voltage to the shutdown pin should not exceed 7.5V. If the use of a higher voltage is desired due to system or other constraints it may be used, however a 100k or larger resistor is recommended between the applied voltage and the shutdown pin to protect the device.

SCHOTTKY DIODE

The breakdown voltage rating of D_1 and D_2 is preferred to be 25% higher than the maximum input voltage. The current rating for the diode should be equal to the maximum output current for best reliability in most applications. In cases where the input voltage is much greater than the output voltage the average diode current is lower. In this case it is possible to use a diode with a lower average current rating, approximately $(1-D) * I_{\text{OUT}}$ however the peak current rating should be higher than the maximum load current.

LOOP COMPENSATION

The general purpose of loop compensation is to meet static and dynamic performance requirements while maintaining stability. Loop gain is what is usually checked to determine small-signal performance. Loop gain is equal to the product of control-output transfer function and the output-control transfer function (the compensation network transfer function). The DC loop gain of the LM2717 is usually around 55dB to 60dB when loaded. Generally speaking it is a good idea to have a loop gain slope that is -20dB /decade from a very low frequency to well beyond the crossover frequency. The crossover frequency should not exceed one-fifth of the switching frequency, i.e. 60kHz in the case of 300kHz switching frequency. The higher the bandwidth is, the faster the load transient response speed will potentially be. However, if the duty cycle saturates during a load transient, further increasing the small signal bandwidth will not help. Since the control-output transfer function usually has very limited low frequency gain, it is a good idea to place a pole in the compensation at zero frequency, so that the low frequency gain will be relatively large. A large DC gain means high DC regulation accuracy (i.e. DC voltage changes little with load or line variations). The rest of the compensation scheme depends highly on the shape of the control-output plot.

As shown in [Figure 17](#), the example control-output transfer function consists of one pole (f_p), one zero (f_z), and a double pole at f_n (half the switching frequency). The following can be done to create a -20dB /decade roll-off of the loop gain: Place the first pole at 0Hz, the first zero at f_p , the second pole at f_z , and the second zero at f_n . The resulting output-control transfer function is shown in [Figure 18](#).

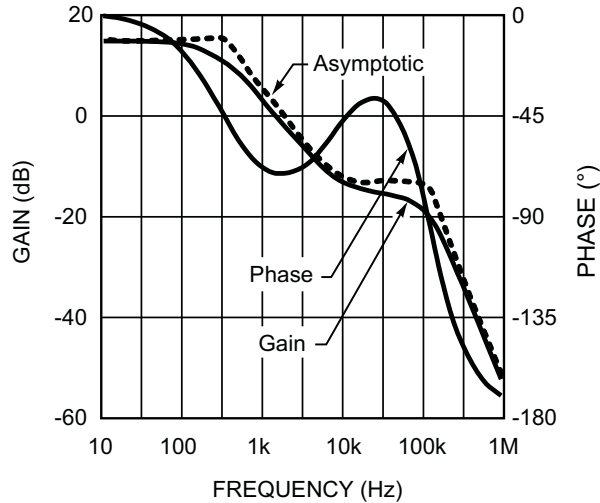

Figure 17. Control-Output Transfer Function

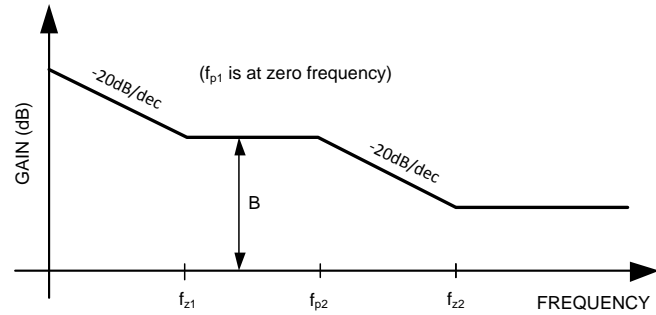

Figure 18. Output-Control Transfer Function

The control-output corner frequencies, and thus the desired compensation corner frequencies, can be determined approximately by the following equations:

$$f_z = \frac{1}{2\pi R_e C_o}$$

where

- C_o is the output capacitance
- R_e is the output capacitance ESR
- f is the switching frequency

(8)

$$f_p = \frac{1}{2\pi R_o C_o} + \frac{.5}{2\pi L f C_o}$$

where

- C_o is the output capacitance
- R_o is the load resistance
- f is the switching frequency

(9)

Since f_p is determined by the output network, it will shift with loading (R_o) and duty cycle. First determine the range of frequencies (f_{pmin}/f_{pmax}) of the pole across the expected load range, then place the first compensation zero within that range.

Example: $V_o = 5V$, $R_e = 20m\Omega$, $C_o = 100\mu F$, $R_{o_{max}} = 5V/100mA = 50\Omega$, $R_{o_{min}} = 5V/1A = 5\Omega$, $L = 10\mu H$, $f = 300kHz$:

$$f_z = \frac{1}{2\pi \cdot 20 \text{ m}\Omega \cdot 100 \mu F} = 80 \text{ kHz}$$

(10)

$$f_{p \text{ min}} = \frac{1}{2\pi \cdot 50\Omega \cdot 100 \mu F} + \frac{0.5}{2\pi \cdot 300k \cdot 10\mu \cdot 100 \mu F} = 297 \text{ Hz}$$

(11)

$$f_{p \text{ max}} = \frac{1}{2\pi \cdot 5\Omega \cdot 100 \mu F} + \frac{0.5}{2\pi \cdot 300k \cdot 10\mu \cdot 100 \mu F} = 584 \text{ Hz}$$

(12)

Once the f_p range is determined, R_{c1} should be calculated using:

$$R_{c1} = \frac{B}{g_m} \left(\frac{R_1 + R_2}{R_1} \right)$$

where

- B is the desired gain in V/V at fp (fz1)
 - gm is the transconductance of the error amplifier
 - R1 and R2 are the feedback resistors as shown in [Figure 19](#)
- (13)

A gain value around 10dB (3.3v/v) is generally a good starting point.

Example: B = 3.3 v/v, gm=1350µmho, R1 = 20 KΩ, R2 = 59 KΩ:

$$R_{c1} = \frac{3.3}{1350\mu} \cdot \frac{20k + 59k}{20k} \approx 9.76k$$

(14)

Bandwidth will vary proportional to the value of Rc1. Next, Cc1 can be determined with the following equation:

$$C_{c1} = \frac{1}{2\pi \cdot f_p \cdot R_{c1}}$$

(15)

Example: fpmin = 297 Hz, Rc1 = 20 KΩ:

$$C_{c1} = \frac{1}{2\pi \cdot 297 \text{ Hz} \cdot 9.76k} \approx 56 \text{ nF}$$

(16)

The value of Cc1 should be within the range determined by fpmin/max. A higher value will generally provide a more stable loop, but too high a value will slow the transient response time.

The compensation network ([Figure 19](#)) will also introduce a low frequency pole which will be close to 0Hz.

A second pole should also be placed at fz. This pole can be created with a single capacitor Cc2 and a shorted Rc2 (see [Figure 19](#)). The minimum value for this capacitor can be calculated by:

$$C_{c2 \text{ min}} = \frac{1}{2\pi \cdot f_z \cdot R_{c1}}$$

(17)

Cc2 may not be necessary, however it does create a more stable control loop. This is especially important with high load currents.

Example: fz = 80 kHz, Rc1 = 20 KΩ:

$$C_{c2 \text{ min}} = \frac{1}{2\pi \cdot 80 \text{ kHz} \cdot 20 \text{ k}\Omega} \cong 100 \text{ pF}$$

(18)

A second zero can also be added with a resistor in series with Cc2. If used, this zero should be placed at fn, where the control to output gain rolls off at -40dB/dec. Generally, fn will be well below the 0dB level and thus will have little effect on stability. Rc2 can be calculated with the following equation:

$$R_{c2} = \frac{1}{2\pi \cdot f_n \cdot C_{c2}}$$

(19)

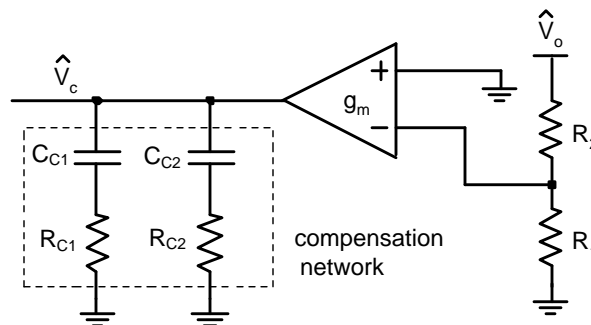

Figure 19. Compensation Network

Note that the values calculated here give a good baseline for stability and will work well with most applications. The values in some cases may need to be adjusted some for optimum stability or the values may need to be adjusted depending on a particular applications bandwidth requirements.

LAYOUT CONSIDERATIONS

The LM2717-ADJ uses two separate ground connections, PGND for the drivers and boost NMOS power device and AGND for the sensitive analog control circuitry. The AGND and PGND pins should be tied directly together at the package. The feedback and compensation networks should be connected directly to a dedicated analog ground plane and this ground plane must connect to the AGND pin. If no analog ground plane is available then the ground connections of the feedback and compensation networks must tie directly to the AGND pin. Connecting these networks to the PGND can inject noise into the system and effect performance.

The input bypass capacitor C_{IN} , as shown in [Figure 20](#), must be placed close to the IC. This will reduce copper trace resistance which effects input voltage ripple of the IC. For additional input voltage filtering, a 0.1 μ F to 4.7 μ F bypass capacitors can be placed in parallel with C_{IN} , close to the V_{IN} pins to shunt any high frequency noise to ground. The output capacitors, C_{OUT1} and C_{OUT2} , should also be placed close to the IC. Any copper trace connections for the C_{OUTX} capacitors can increase the series resistance, which directly effects output voltage ripple. The feedback network, resistors $R_{FB1(3)}$ and $R_{FB2(4)}$, should be kept close to the FB pin, and away from the inductor to minimize copper trace connections that can inject noise into the system. Trace connections made to the inductors and schottky diodes should be minimized to reduce power dissipation and increase overall efficiency. For more detail on switching power supply layout considerations see Application Note AN-1149: *Layout Guidelines for Switching Power Supplies* ([SNVA021](#)).

APPLICATION INFORMATION

Table 1. Some Recommended Inductors (Others May Be Used)

Manufacturer	Inductor	Contact Information
Coilcraft	DO3316 and DT3316 series	www.coilcraft.com 800-3222645
TDK	SLF10145 series	www.component.tdk.com 847-803-6100
Pulse	P0751 and P0762 series	www.pulseeng.com
Sumida	CDRH8D28 and CDRH8D43 series	www.sumida.com

Table 2. Some Recommended Input And Output Capacitors (Others May Be Used)

Manufacturer	Capacitor	Contact Information
Vishay Sprague	293D, 592D, and 595D series tantalum	www.vishay.com
Taiyo Yuden	High capacitance MLCC ceramic	www.t-yuden.com
Cornell Dubilier	ESRD series Polymer Aluminum Electrolytic SPV and AFK series V-chip series	www.cde.com
MuRata	High capacitance MLCC ceramic	www.murata.com

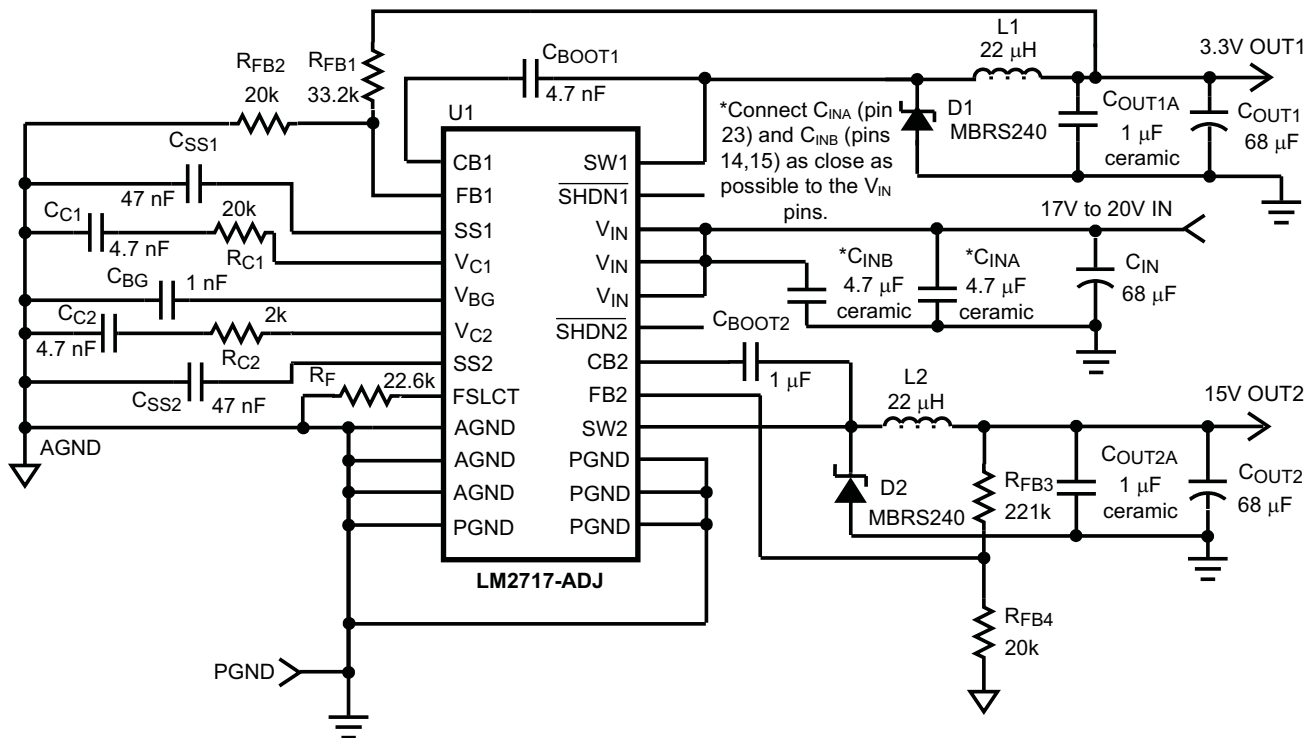

Figure 20. 15V, 3.3V Output Application

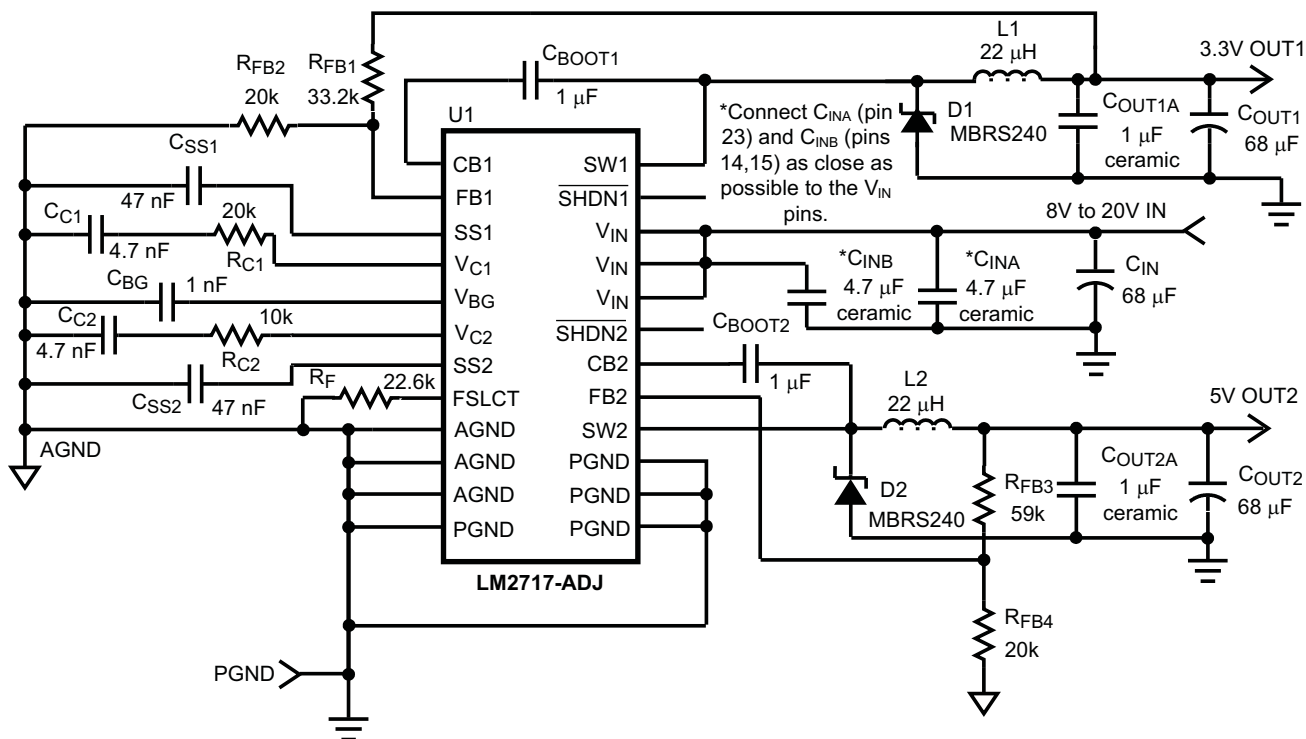

Figure 21. 5V, 3.3V Output Application

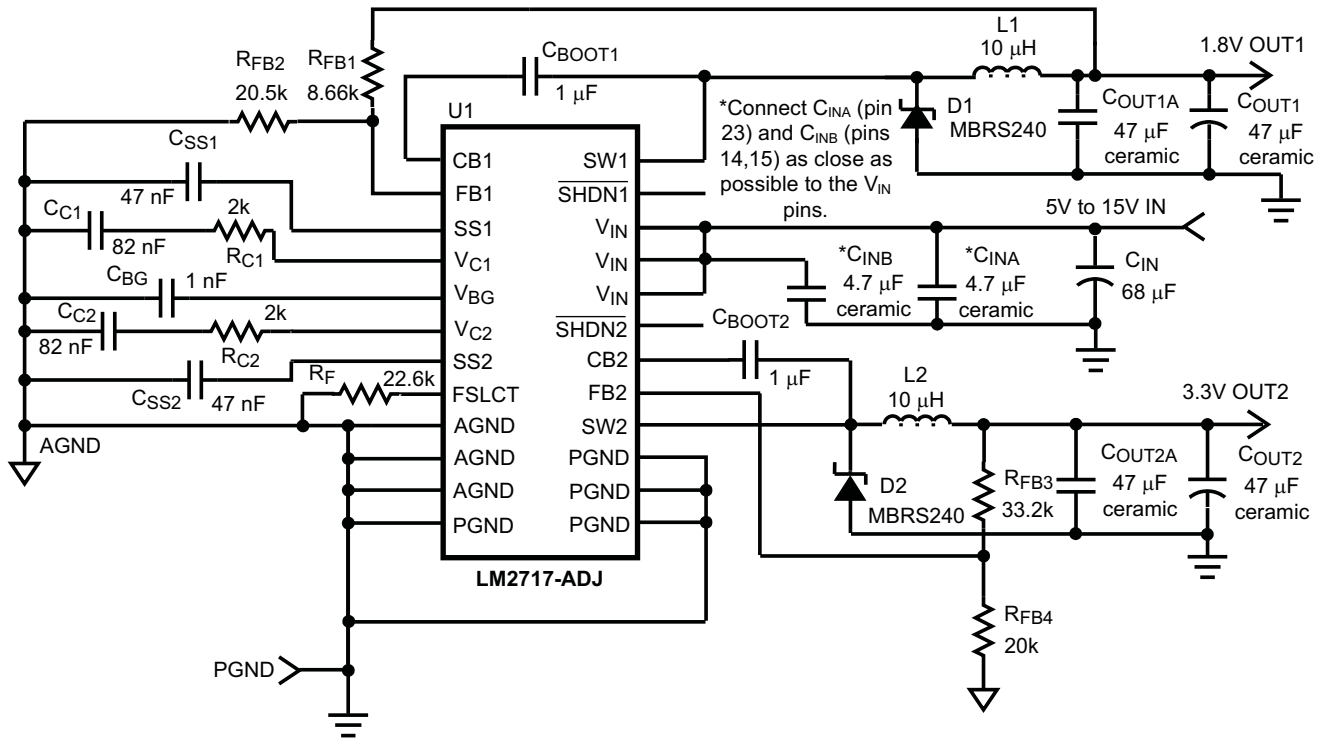

Figure 22. 3.3V, 1.8V Output Application

REVISION HISTORY

Changes from Revision B (March 2013) to Revision C	Page
• Changed layout of National Data Sheet to TI format	18

PACKAGING INFORMATION

Orderable Device	Status (1)	Package Type	Package Drawing	Pins	Package Qty	Eco Plan (2)	Lead/Ball Finish	MSL Peak Temp (3)	Op Temp (°C)	Device Marking (4/5)	Samples
LM2717MT-ADJ/NOPB	ACTIVE	TSSOP	PW	24	61	Green (RoHS & no Sb/Br)	CU SN	Level-1-260C-UNLIM	-40 to 125	LM2717 MT-ADJ	Samples
LM2717MTX-ADJ/NOPB	ACTIVE	TSSOP	PW	24	2500	Green (RoHS & no Sb/Br)	CU SN	Level-1-260C-UNLIM	-40 to 125	LM2717 MT-ADJ	Samples

(1) The marketing status values are defined as follows:

ACTIVE: Product device recommended for new designs.

LIFEBUY: TI has announced that the device will be discontinued, and a lifetime-buy period is in effect.

NRND: Not recommended for new designs. Device is in production to support existing customers, but TI does not recommend using this part in a new design.

PREVIEW: Device has been announced but is not in production. Samples may or may not be available.

OBSOLETE: TI has discontinued the production of the device.

(2) Eco Plan - The planned eco-friendly classification: Pb-Free (RoHS), Pb-Free (RoHS Exempt), or Green (RoHS & no Sb/Br) - please check <http://www.ti.com/productcontent> for the latest availability information and additional product content details.

TBD: The Pb-Free/Green conversion plan has not been defined.

Pb-Free (RoHS): TI's terms "Lead-Free" or "Pb-Free" mean semiconductor products that are compatible with the current RoHS requirements for all 6 substances, including the requirement that lead not exceed 0.1% by weight in homogeneous materials. Where designed to be soldered at high temperatures, TI Pb-Free products are suitable for use in specified lead-free processes.

Pb-Free (RoHS Exempt): This component has a RoHS exemption for either 1) lead-based flip-chip solder bumps used between the die and package, or 2) lead-based die adhesive used between the die and leadframe. The component is otherwise considered Pb-Free (RoHS compatible) as defined above.

Green (RoHS & no Sb/Br): TI defines "Green" to mean Pb-Free (RoHS compatible), and free of Bromine (Br) and Antimony (Sb) based flame retardants (Br or Sb do not exceed 0.1% by weight in homogeneous material)

(3) MSL, Peak Temp. -- The Moisture Sensitivity Level rating according to the JEDEC industry standard classifications, and peak solder temperature.

(4) There may be additional marking, which relates to the logo, the lot trace code information, or the environmental category on the device.

(5) Multiple Device Markings will be inside parentheses. Only one Device Marking contained in parentheses and separated by a "~" will appear on a device. If a line is indented then it is a continuation of the previous line and the two combined represent the entire Device Marking for that device.

Important Information and Disclaimer: The information provided on this page represents TI's knowledge and belief as of the date that it is provided. TI bases its knowledge and belief on information provided by third parties, and makes no representation or warranty as to the accuracy of such information. Efforts are underway to better integrate information from third parties. TI has taken and continues to take reasonable steps to provide representative and accurate information but may not have conducted destructive testing or chemical analysis on incoming materials and chemicals. TI and TI suppliers consider certain information to be proprietary, and thus CAS numbers and other limited information may not be available for release.

In no event shall TI's liability arising out of such information exceed the total purchase price of the TI part(s) at issue in this document sold by TI to Customer on an annual basis.

TAPE AND REEL INFORMATION

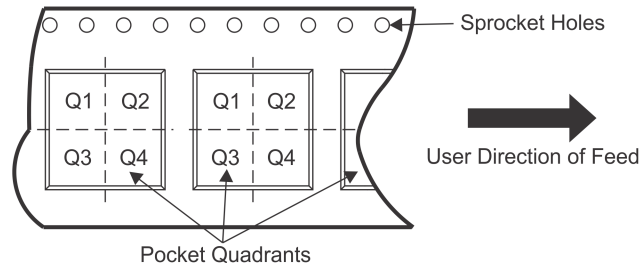
QUADRANT ASSIGNMENTS FOR PIN 1 ORIENTATION IN TAPE

*All dimensions are nominal

Device	Package Type	Package Drawing	Pins	SPQ	Reel Diameter (mm)	Reel Width W1 (mm)	A0 (mm)	B0 (mm)	K0 (mm)	P1 (mm)	W (mm)	Pin1 Quadrant
LM2717MTX-ADJ/NOPB	TSSOP	PW	24	2500	330.0	16.4	6.95	8.3	1.6	8.0	16.0	Q1

TAPE AND REEL BOX DIMENSIONS

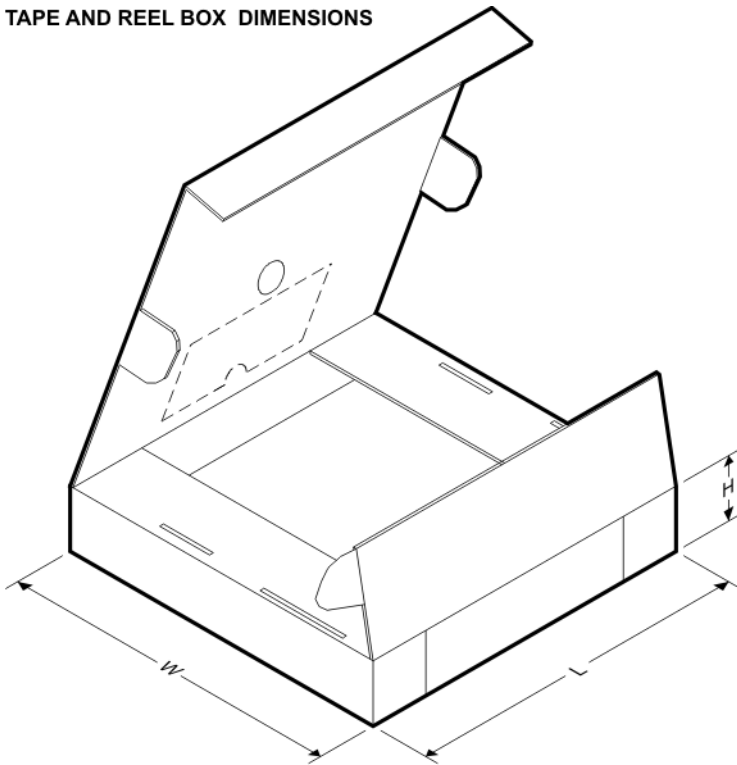

*All dimensions are nominal

Device	Package Type	Package Drawing	Pins	SPQ	Length (mm)	Width (mm)	Height (mm)
LM2717MTX-ADJ/NOPB	TSSOP	PW	24	2500	367.0	367.0	35.0

PW0024A



PACKAGE OUTLINE
TSSOP - 1.2 mm max height

SMALL OUTLINE PACKAGE

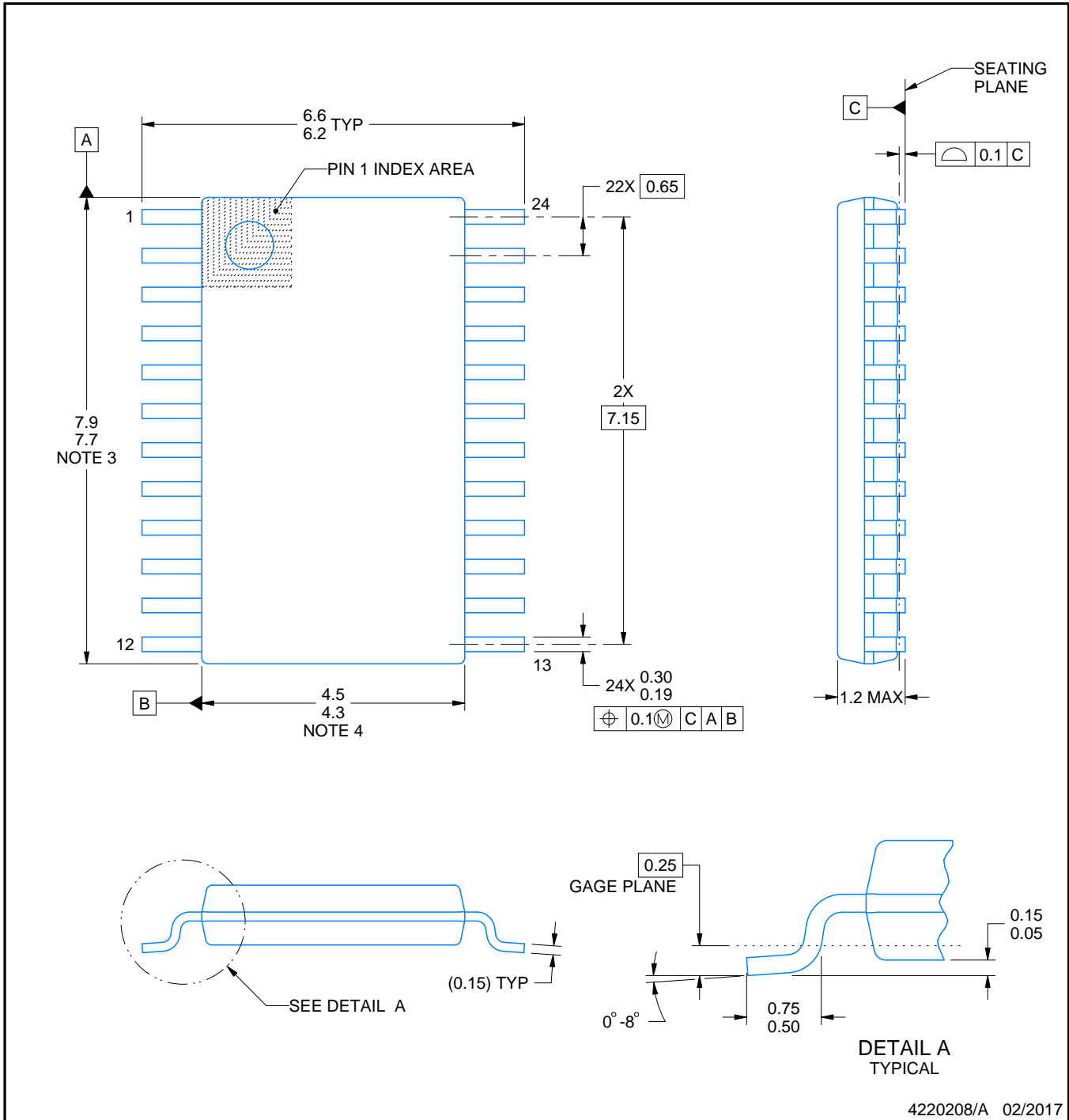

4220208/A 02/2017

NOTES:

1. All linear dimensions are in millimeters. Any dimensions in parenthesis are for reference only. Dimensioning and tolerancing per ASME Y14.5M.
2. This drawing is subject to change without notice.
3. This dimension does not include mold flash, protrusions, or gate burrs. Mold flash, protrusions, or gate burrs shall not exceed 0.15 mm per side.
4. This dimension does not include interlead flash. Interlead flash shall not exceed 0.25 mm per side.
5. Reference JEDEC registration MO-153.

EXAMPLE BOARD LAYOUT

PW0024A

TSSOP - 1.2 mm max height

SMALL OUTLINE PACKAGE

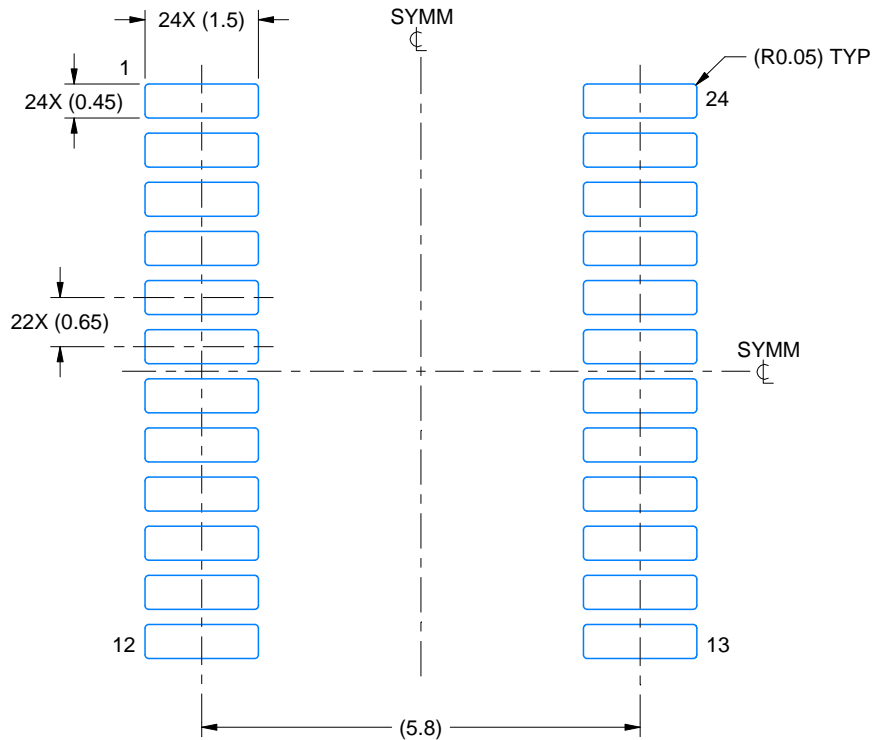

LAND PATTERN EXAMPLE
EXPOSED METAL SHOWN
SCALE: 10X

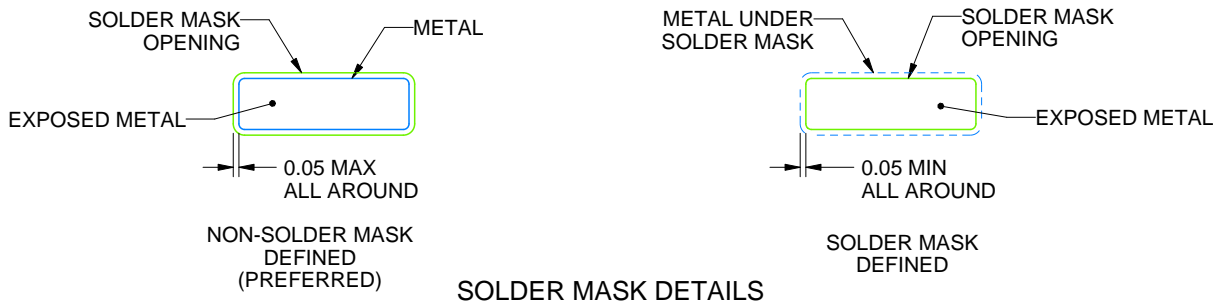

SOLDER MASK DETAILS

4220208/A 02/2017

NOTES: (continued)

- 6. Publication IPC-7351 may have alternate designs.
- 7. Solder mask tolerances between and around signal pads can vary based on board fabrication site.

EXAMPLE STENCIL DESIGN

PW0024A

TSSOP - 1.2 mm max height

SMALL OUTLINE PACKAGE

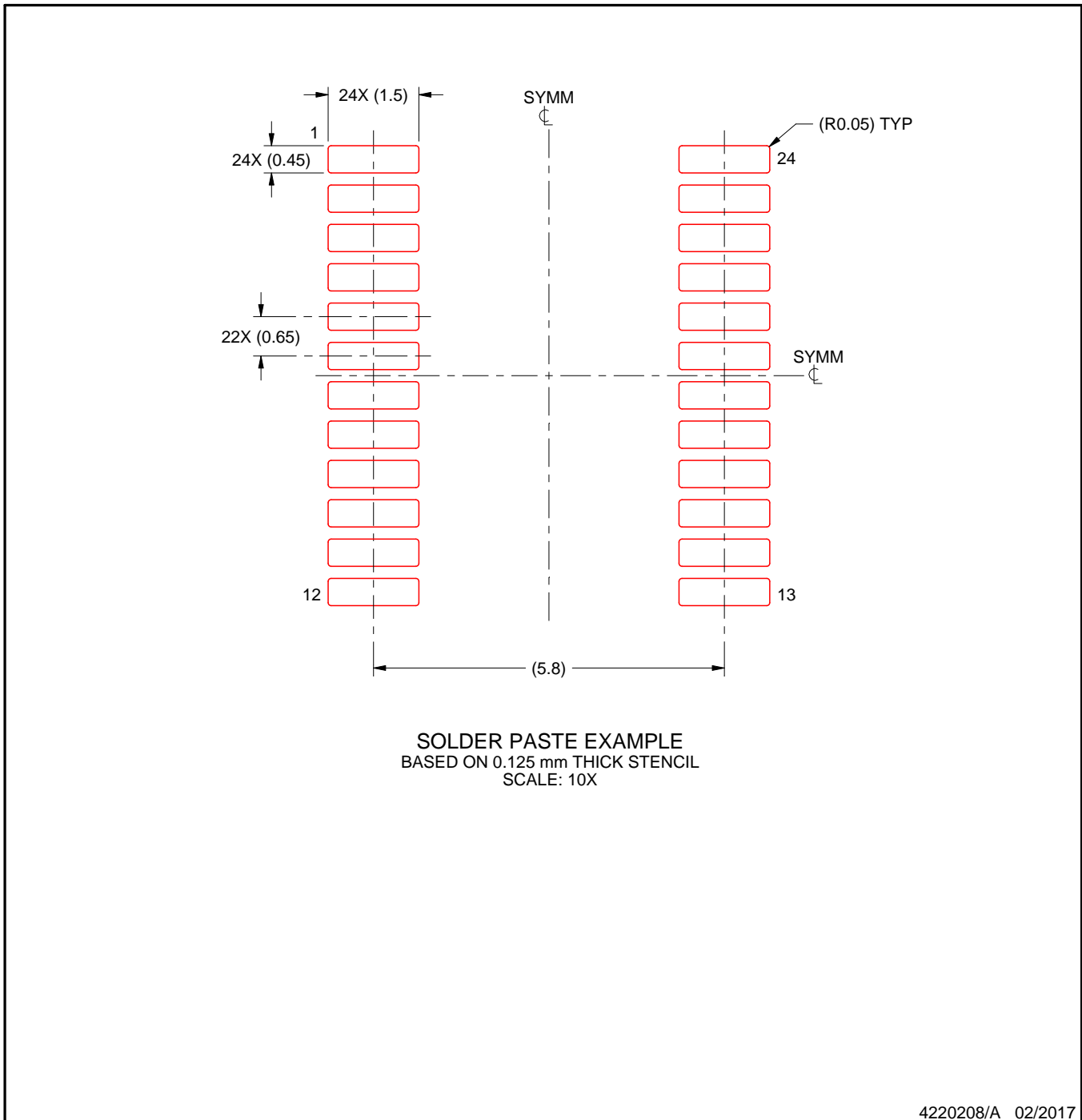

NOTES: (continued)

8. Laser cutting apertures with trapezoidal walls and rounded corners may offer better paste release. IPC-7525 may have alternate design recommendations.
9. Board assembly site may have different recommendations for stencil design.

IMPORTANT NOTICE AND DISCLAIMER

TI PROVIDES TECHNICAL AND RELIABILITY DATA (INCLUDING DATASHEETS), DESIGN RESOURCES (INCLUDING REFERENCE DESIGNS), APPLICATION OR OTHER DESIGN ADVICE, WEB TOOLS, SAFETY INFORMATION, AND OTHER RESOURCES "AS IS" AND WITH ALL FAULTS, AND DISCLAIMS ALL WARRANTIES, EXPRESS AND IMPLIED, INCLUDING WITHOUT LIMITATION ANY IMPLIED WARRANTIES OF MERCHANTABILITY, FITNESS FOR A PARTICULAR PURPOSE OR NON-INFRINGEMENT OF THIRD PARTY INTELLECTUAL PROPERTY RIGHTS.

These resources are intended for skilled developers designing with TI products. You are solely responsible for (1) selecting the appropriate TI products for your application, (2) designing, validating and testing your application, and (3) ensuring your application meets applicable standards, and any other safety, security, or other requirements. These resources are subject to change without notice. TI grants you permission to use these resources only for development of an application that uses the TI products described in the resource. Other reproduction and display of these resources is prohibited. No license is granted to any other TI intellectual property right or to any third party intellectual property right. TI disclaims responsibility for, and you will fully indemnify TI and its representatives against, any claims, damages, costs, losses, and liabilities arising out of your use of these resources.

TI's products are provided subject to TI's Terms of Sale (www.ti.com/legal/termsofsale.html) or other applicable terms available either on ti.com or provided in conjunction with such TI products. TI's provision of these resources does not expand or otherwise alter TI's applicable warranties or warranty disclaimers for TI products.

Mailing Address: Texas Instruments, Post Office Box 655303, Dallas, Texas 75265
Copyright © 2019, Texas Instruments Incorporated

Looking for pricing, stock, or lifecycle information?

Click below to explore more details on WIN SOURCE:

- ⊖ [View LM2717MTX-ADJ/NOPB on WIN SOURCE](#)
- ⊖ [Texas Instruments](#) Information

Optimize Your Supply Chain with WIN SOURCE Solutions

- ✓ Global Sourcing Solution
- ✓ Obsolete Management
- ✓ Cost Control Management
- ✓ Shortage Management
- ✓ Alternative Solution
- ✓ Excess Inventory Management