

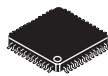

# THE DATASHEET OF ADS7890IPFBT





## 14-BIT, 1.25-MSPS LOW POWER SAR ANALOG-TO-DIGITAL CONVERTER

### FEATURES

- 1.25 MHz Sample Rate, 14-Bit Resolution
- Zero Latency
- Unipolar, Pseudo Differential Input, Range:
  - 0 V to 2.5 V
- SPI™ Compatible Serial Interface
- 77.5 dB SNR and –95 dB THD at 0.5 MHz I/P
- Power Dissipation 45 mW at 1.25 MSPS
- Nap Mode (10 mW Power Dissipation)
- Power Down (10 μW)
- Internal Reference
- Internal Reference Buffer
- 48-Pin TQFP Package

### APPLICATIONS

- Optical Networking (DWDM, MEMS Based Switching)
- Spectrum Analyzers
- High Speed Data Acquisition Systems
- High Speed Close-Loop Systems
- Telecommunication

### DESCRIPTION

The ADS7890 is a 14-bit 1.25-MSPS A-to-D converter with 2.5-V internal reference. The device includes a capacitor based SAR A/D converter with inherent sample and hold. The device offers a 14-bit serial SPI or DSP compatible interface. The device has a pseudo-differential input stage.

The –IN swing of ±200 mV is useful to compensate for ground voltage mismatch between the ADC and sensor and also to cancel common-mode noise. The device operates at lower power when used at lower conversion rates because of the nap feature. The device is available in a 48-pin TQFP package.

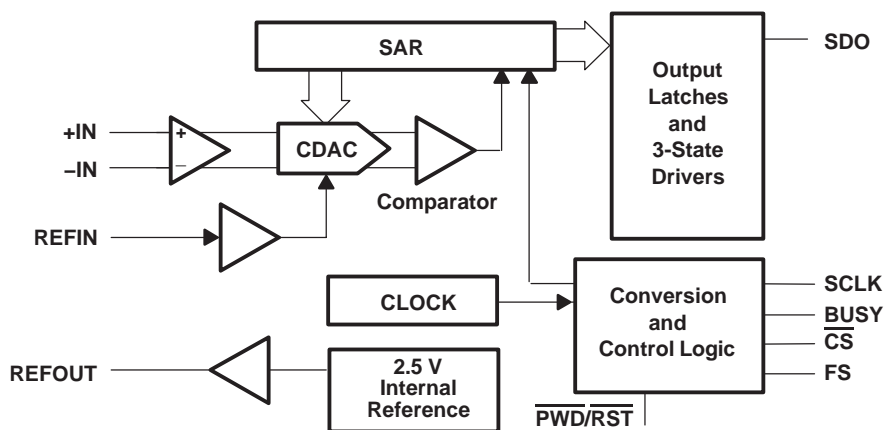

Please be aware that an important notice concerning availability, standard warranty, and use in critical applications of Texas Instruments semiconductor products and disclaimers thereto appears at the end of this data sheet.

SPI is a trademark of Motorola, Inc.

# ADS7890

SLAS409 – DECEMBER 2003



This integrated circuit can be damaged by ESD. Texas Instruments recommends that all integrated circuits be handled with appropriate precautions. Failure to observe proper handling and installation procedures can cause damage.

ESD damage can range from subtle performance degradation to complete device failure. Precision integrated circuits may be more susceptible to damage because very small parametric changes could cause the device not to meet its published specifications.

## ORDERING INFORMATION

MODEL	MAXIMUM INTEGRAL LINEARITY (LSB)	MAXIMUM DIFFERENTIAL LINEARITY (LSB)	NO MISSING CODES AT RESOLUTION (BIT)	PACKAGE TYPE	PACKAGE DESIGNATOR	TEMPERATURE RANGE	ORDERING INFORMATION	TRANSPORT MEDIA QUANTITY
ADS7890	±1.5	+1.5/-1	14	48-Pin TQFP	PFB	-40°C to 85°C	ADS7890IPFBT	Tape and reel 250
							ADS7890IPFBR	Tape and reel 1000

NOTE: For most current specifications and package information, refer to the TI website at [www.ti.com](http://www.ti.com).

## ABSOLUTE MAXIMUM RATINGS

over operating free-air temperature range<sup>(1)</sup>

		UNIT
+IN to AGND		-0.3 V to +VA + 0.1 V
-IN to AGND		-0.3 V to 0.5 V
+VA to AGND		-0.3 V to 7 V
+VBD to BDGND		-0.3 V to 7 V
Digital input voltage to GND		-0.3 V to (+VBD + 0.3 V)
Digital output to GND		-0.3 V to (+VBD + 0.3 V)
Operating temperature range		-40°C to 85°C
Storage temperature range		-65°C to 150°C
Junction temperature (T <sub>Jmax</sub> )		150°C
TQFP package	Power dissipation	(T <sub>J Max</sub> -T <sub>A</sub> )/ θ <sub>JA</sub>
	θ <sub>JA</sub> Thermal impedance	86°C/W
Lead temperature, soldering	Vapor phase (60 sec)	215°C
	Infrared (15 sec)	220°C

<sup>(1)</sup> Stresses beyond those listed under “absolute maximum ratings” may cause permanent damage to the device. These are stress ratings only, and functional operation of the device at these or any other conditions beyond those indicated under “recommended operating conditions” is not implied. Exposure to absolute-maximum-rated conditions for extended periods may affect device reliability.

**SPECIFICATIONS**
 $T_A = -40^\circ\text{C}$  to  $85^\circ\text{C}$ ,  $+V_A = 5\text{ V}$ ,  $+V_{BD} = 5\text{ V}$  or  $3.3\text{ V}$ ,  $V_{\text{ref}} = 2.5\text{ V}$ ,  $f_{\text{sample}} = 1.25\text{ MHz}$  (unless otherwise noted)

PARAMETER	TEST CONDITIONS	MIN	TYP	MAX	UNIT
<b>ANALOG INPUT</b>					
Full-scale input span <sup>(1)</sup>	+IN – (–IN)	0		$V_{\text{ref}}$	V
Absolute input range	+IN	–0.2		$V_{\text{ref}} + 0.2$	V
	–IN	–0.2		+0.2	
Input capacitance			27		pF
Input leakage current			500		pA
<b>SYSTEM PERFORMANCE</b>					
Resolution			14		Bits
No missing codes		14			Bits
Integral linearity <sup>(2)</sup>		–1.5	$\pm 0.75$	1.5	LSB <sup>(3)</sup>
Differential linearity		–1	$\pm 0.75$	1.5	LSB <sup>(3)</sup>
Offset error <sup>(4)</sup>	External reference	–1.5	$\pm 0.5$	1.5	mV
Gain error <sup>(4)</sup>	External reference	–1	$\pm 0.25$	1	mV
Common-mode rejection ratio	With common mode input signal = 200 mVp–p at 0.5 MHz		60		dB
Power supply rejection	At 3FF0H output code, $+V_A = 4.75\text{ V}$ to $5.25\text{ V}$ , $V_{\text{ref}} = 2.50\text{ V}$		80		dB
<b>SAMPLING DYNAMICS</b>					
Conversion time	+V <sub>DB</sub> = 5 V			365	nsec
	+V <sub>DB</sub> = 3 V			365	nsec
Acquisition time	+V <sub>DB</sub> = 5 V	187.5			nsec
	+V <sub>DB</sub> = 3 V	187.5			nsec
Maximum throughput rate				1.25	MHz
Aperture delay			5		nsec
Aperture jitter			20		psec
Step response			50		nsec
Over voltage recovery			50		nsec
<b>DYNAMIC CHARACTERISTICS</b>					
Total harmonic distortion <sup>(5)</sup>	$V_{\text{IN}} = 2.496\text{ V}_{\text{p-p}}$ at 100 kHz/2.5 V <sub>ref</sub>		–95		dB
	$V_{\text{IN}} = 2.496\text{ V}_{\text{p-p}}$ at 0.5 MHz/2.5 V <sub>ref</sub>		–95	–88	
SNR	$V_{\text{IN}} = 2.496\text{ V}_{\text{p-p}}$ at 100 kHz/2.5 V <sub>ref</sub>		78		dB
	$V_{\text{IN}} = 2.496\text{ V}_{\text{p-p}}$ at 0.5 MHz/2.5 V <sub>ref</sub>		77.5		
SINAD	$V_{\text{IN}} = 2.496\text{ V}_{\text{p-p}}$ at 100 kHz/2.5 V <sub>ref</sub>		77		dB
	$V_{\text{IN}} = 2.496\text{ V}_{\text{p-p}}$ at 0.5 MHz/2.5 V <sub>ref</sub>		77		
SFDR	$V_{\text{IN}} = 2.496\text{ V}_{\text{p-p}}$ at 0.5 MHz/2.5 V <sub>ref</sub>	89	97		dB
–3 dB Small signal bandwidth			50		MHz
<b>EXTERNAL REFERENCE INPUT</b>					
Input V <sub>REF</sub> range		2.4	2.5	2.6	V
Resistance <sup>(6)</sup>			500		k $\Omega$

(1) Ideal input span; does not include gain or offset error.

(2) This is endpoint INL, not best fit.

(3) LSB means least significant bit.

(4) Measured relative to actual measured reference.

(5) Calculated on the first nine harmonics of the input frequency.

(6) Can vary  $\pm 20\%$ .

# ADS7890

SLAS409 – DECEMBER 2003

## SPECIFICATIONS Continued

 $T_A = -40^{\circ}\text{C}$  to  $85^{\circ}\text{C}$ ,  $+V_A = 5\text{ V}$ ,  $+V_{BD} = 5\text{ V}$  or  $3.3\text{ V}$ ,  $V_{ref} = 2.5\text{ V}$ ,  $f_{sample} = 1.25\text{ MHz}$  (unless otherwise noted)

PARAMETER		TEST CONDITIONS	MIN	TYP	MAX	UNIT
<b>INTERNAL REFERENCE OUTPUT</b>						
Start-up time		From 95% (+VA), with 1- $\mu\text{F}$ storage capacitor on REFOUT to AGND			120	msec
VREF Range		IOUT=0	2.48	2.5	2.52	V
Source current		Static load			10	$\mu\text{A}$
Line regulation		+VA = 4.75 V to 5.25 V		1		mV
Drift		IOUT = 0		25		PPM/C
<b>DIGITAL INPUT/OUTPUT</b>						
Logic family			CMOS			
Logic level	$V_{IH}$	$I_{IH} = 5\ \mu\text{A}$	$+V_{BD} - 1$		$+V_{BD} + 0.3$	
	$V_{IL}$	$I_{IL} = 5\ \mu\text{A}$	-0.3		0.8	V
	$V_{OH}$	$I_{OH} = 2\ \text{TTL loads}$	$+V_{BD} - 0.6$		$+V_{BD}$	V
	$V_{OL}$	$I_{OL} = 2\ \text{TTL loads}$	0		0.4	V
Data format			Straight Binary			
<b>POWER SUPPLY REQUIREMENTS</b>						
Power supply voltage	+VBD		2.7	3.3	5.25	V
	+VA		4.75	5	5.25	V
Supply current, +VA, 1.25 MHz sample rate				9	12	mA
Power dissipation, 1.25 MHz sample rate		+VA = 5 V		45	60	mW
<b>NAP MODE</b>						
Supply current, +VA				2	3	mA
<b>POWER DOWN</b>						
Supply current, +VA				2	2.5	$\mu\text{A}$
Power down time <sup>(1)</sup>				10		$\mu\text{sec}$
Power up time		1- $\mu\text{F}$ Storage capacitor on REFOUT to AGND		25		msec
Invalid conversions after power up or reset					4	Numbers
<b>TEMPERATURE RANGE</b>						
Operating free-air			-40		85	$^{\circ}\text{C}$

<sup>(1)</sup> Time required to reach level of 2.5  $\mu\text{A}$ .

**TIMING REQUIREMENTS**

 All specifications typical at  $-40^{\circ}\text{C}$  to  $85^{\circ}\text{C}$ ,  $+V_A = +5\text{ V}$ ,  $+V_{BD} = +5\text{ V}$  (see Notes 1, 2, and 3)

PARAMETER	SYMBOL	MIN	TYP	MAX	UNITS	REF FIG.
Conversion time	$t_{\text{conv}}$			365	ns	1,2
Acquisition time	$t_{\text{acq}}$	187.5			ns	1,2
Cycle time, SCLK	$t_{\text{cyc}}$	25			ns	1,2
Pulse duration, SCLK low	$t_{\text{wL}}$	10			ns	
Pulse duration, SCLK high	$t_{\text{wH}}$	10			ns	
<b>DSP INTERFACE</b>						
Setup time $\overline{\text{CS}}$ low to FS high	$t_{\text{su1}}$	8			ns	2
Delay time FS high to MSB valid	$t_{\text{d1}}$			9	ns	2
FS pulse duration	$t_{\text{w1}}$	15			ns	2
Hold time, SCLK falling edge to FS falling edge (last SCLK falling edge when FS high)	$t_{\text{h1}}$	5			ns	2
Setup time, FS falling edge to first falling edge of SCLK after FS low	$t_{\text{su2}}$	5			ns	2
Hold time, internal conversion (indicated by $t_{\text{conv}}$ ) end to FS rising edge to avoid conversion abort	$t_{\text{h3}}$	10			ns	2
Delay time, 9th SCLK rising edge to FS rising edge for frame abort during sample	$t_{\text{d8}}$	5			ns	10
<b>SPI INTERFACE</b>						
Pulse duration, $\overline{\text{CS}}$ minimum	$t_{\text{w5}}$	15			ns	1
Hold time, SCLK falling edge (last SCLK falling edge when $\overline{\text{CS}}$ is high) to $\overline{\text{CS}}$ falling edge	$t_{\text{h2}}$	5			ns	1
Setup time, $\overline{\text{CS}}$ low to first SCLK falling edge after $\overline{\text{CS}}$ low	$t_{\text{su3}}$	5			ns	1
Delay time, $\overline{\text{CS}}$ low to MSB valid	$t_{\text{d3}}$			9	ns	1
Hold time, internal conversion (indicated by $t_{\text{conv}}$ ) end to $\overline{\text{CS}}$ falling edge to avoid conversion abort	$t_{\text{h3}}$	10			ns	1
<b>DSP AND SPI INTERFACE</b>						
Delay time, SCLK rising edge to SDO valid	$t_{\text{d2}}$			9	ns	1, 2
Hold time, 16th SCLK falling edge to $\overline{\text{CS}}$ rising edge	$t_{\text{h4}}$	10			ns	1, 2
Delay time, 16th SCLK falling edge to BUSY rising edge	$t_{\text{d4}}$			40	ns	1, 2
Pulse duration, BUSY high	$t_{\text{w2}}$			365	ns	1, 2
Delay time, 9th SCLK rising edge to $\overline{\text{CS}}$ rising edge for frame abort during sample	$t_{\text{d8}}$	5			ns	6, 11
Delay time, $\overline{\text{CS}}$ high to SDO three-state	$t_{\text{d5}}$			10	ns	1, 2
<b>POWER DOWN/RESET</b>						
Pulse width, low for $\overline{\text{PWD/RST}}$ to reset the device	$t_{\text{w3}}$	45		6140	ns	4
Pulse width, low for $\overline{\text{PWD/RST}}$ to power down the device	$t_{\text{w4}}$	7200			ns	3
Delay time, power up after $\overline{\text{PWD/RST}}$ is high	$t_{\text{d6}}$			25	ms	3
Delay time, falling edge of $\overline{\text{PWD/RST}}$ to SDO three-state	$t_{\text{d7}}$			10	ns	3, 4

 (1) All input signals are specified with  $t_r = t_f = 5\text{ ns}$  (10% to 90% of  $+V_{BD}$ ) and timed from a voltage level of  $(V_{IL} + V_{IH})/2$ .

(2) See timing diagram.

 (3) All timings are measured with 20-pF equivalent loads at 5 V  $+V_{BD}$  and 10-pF equivalent loads at 3 V  $+V_{BD}$  on the SDO and BUSY pins.

# ADS7890

SLAS409 – DECEMBER 2003

## PIN ASSIGNMENTS

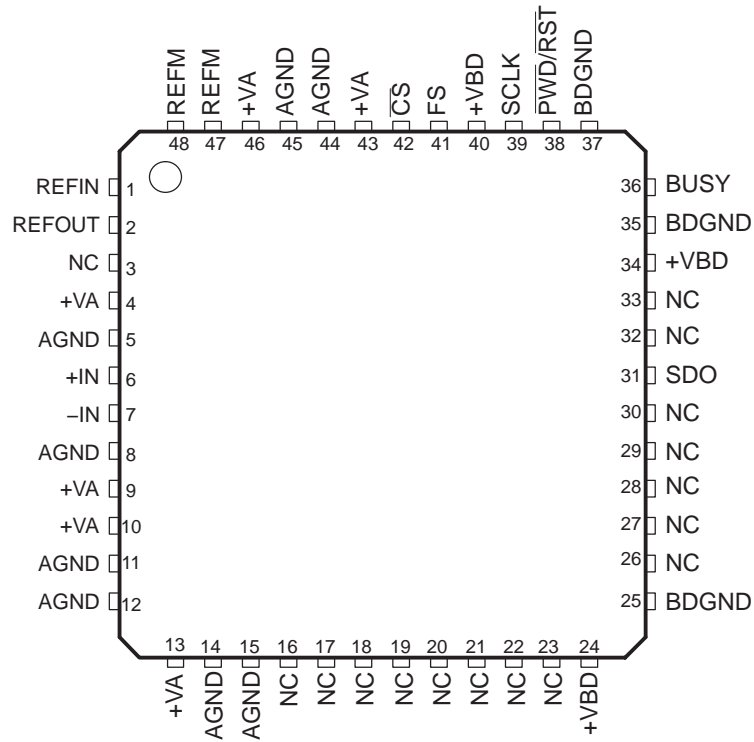

NC – No connection

## Terminal Functions

PIN	NAME	I/O	DESCRIPTION
31	SDO	O	Serial data out. Data (excluding MSB) is latched out on the rising of SCLK with MSB first format. MSB is latched with the rising edge of FS or falling edge of CS depending on whether a DSP or SPI interface is used.
36	BUSY	O	Status output. This pin is high when a conversion is in progress.
39	SCLK	I	Serial clock. The device needs a minimum of 16 clocks per frame. As described in the timing diagrams, it controls serial data out (first 14 clocks), powerup (from nap) on the 8th rising edge of SCLK, start of sample (track) on the 9th rising edge and end of sample or start of conversion on the 16th falling edge of SCLK. The clock can be stopped after the 16th falling edge. It is important to have minimum jitter on SCLK as it decides the sampling instance and the jitter results in a loss of SNR performance.
41	FS	I	Frame sync. The rising edge of FS starts a new sample and convert frame. The MSB from the previous conversion is latched out on the rising edge of FS. The rising edge of FS during an internal convert (see Figure 12) aborts the conversion and starts a new frame.
42	$\overline{\text{CS}}$	I	Chip Select. Active low signal. The falling edge of $\overline{\text{CS}}$ starts a new sample and convert frame. The MSB from the previous conversion is latched out on the falling edge of $\overline{\text{CS}}$ . This signal can be pulled high after the 16th falling edge of SCLK during the frame. SDO goes to three-state with $\overline{\text{CS}}$ high. The falling edge of $\overline{\text{CS}}$ during internal convert (see Figure 7) aborts the conversion and starts a new frame.
24, 34, 40	+VBD		Digital power supply for all digital inputs and outputs. Refer to Table 2 for layout guidelines.
25, 35, 37	BDGND		Digital ground for all digital inputs and outputs. Needs to be shorted to analog ground plane below the device.
38	$\overline{\text{PWD/RST}}$	I	Active low input, acts as device power down/device reset signal.
5, 8, 11, 12, 14, 15, 44, 45	AGND		Analog ground pins. Need to be shorted to analog ground plane below the device.
4, 9, 10, 13, 43, 46	+VA		Analog power supplies. Refer to Table 2 for layout guidelines.
6	+IN	I	Non inverting analog input channel
7	-IN	I	Inverting analog input channel
1	REFIN	I	Reference (positive) input. Needs to be decoupled with REFM pin using 0.1- $\mu\text{F}$ bypass capacitor and 1- $\mu\text{F}$ storage capacitor.
2	REFOUT	O	Internal reference output. To be shorted to REFIN pin when internal reference is used. Do not connect to REFIN pin when external reference is used. Always needs to be decoupled with AGND using 0.1- $\mu\text{F}$ bypass capacitor.
47, 48	REFM	I	Reference ground. To be connected to analog ground plane.
3, 16 – 23, 26 – 30, 32, 33	NC		No connection pins.

## DESCRIPTION AND TIMING DIAGRAMS

### DEVICE OPERATION WITH SPI INTERFACE (See Figure 1)

Device operation is controlled with  $\overline{\text{CS}}$  and SCLK with FS always held high. The frame starts with the falling edge of  $\overline{\text{CS}}$ . The MSB is latched out first on the SDO pin. The clock cycle, with the first falling edge after the falling edge of  $\overline{\text{CS}}$ , is counted as first clock. Subsequent data bits are latched out on the SDO pin with every rising edge of further clocks (until the 14th rising edge of SCLK). The device has a built-in NAP mode. The device enters the NAP state with an end of conversion and continues to be in this state until the 8th SCLK rising edge. The sampling switch is closed on the 9th SCLK rising edge and the device samples the analog input [+IN– (-IN)] and enters the conversion phase on the 16th SCLK falling edge. The BUSY signal goes high to indicate the conversion is in progress and continues to be high until the end of conversion. A new frame can be started with the end of conversion.

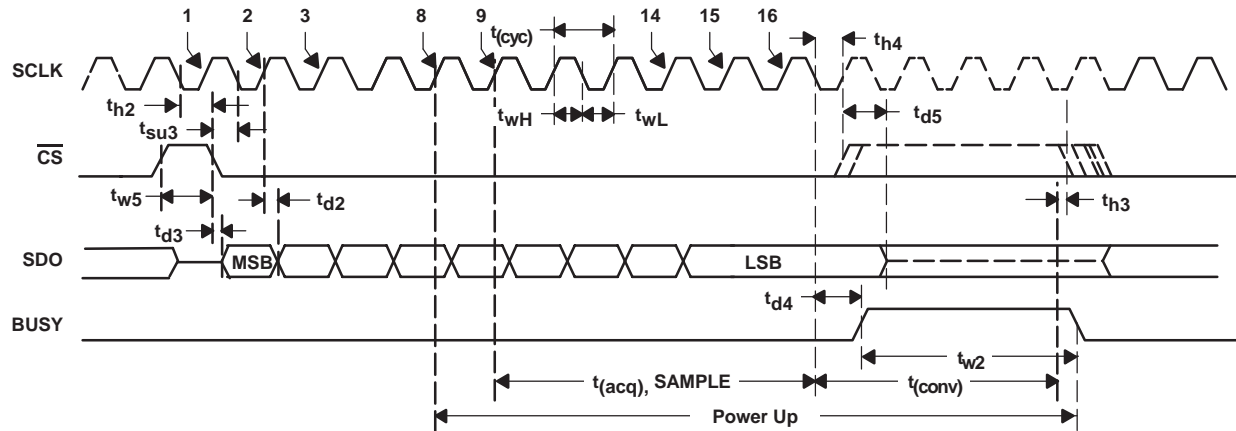
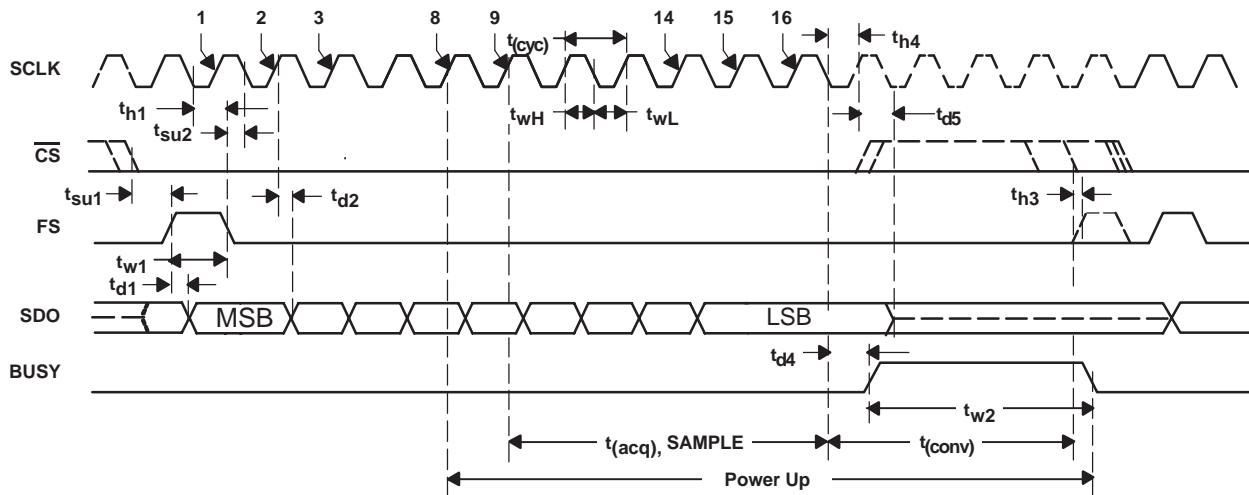

**Figure 1. Device Operation With SPI Interface (FS Held High)**

### DEVICE OPERATION WITH DSP INTERFACE (See Figure 2)

Device operation is controlled with  $\overline{CS}$ , SCLK, and FS. The frame starts with the rising edge of FS with  $\overline{CS}$  already low. The MSB is latched out first on the SDO pin. The clock cycle, with the first falling edge after the falling edge of FS is counted as first clock. Subsequent data bits are latched out on the SDO pin with every rising edge of further clocks (until the 14th rising edge of SCLK). The device has a built-in NAP mode. The device enters the NAP state with an end of conversion and continues to be in this state until the 8th SCLK rising edge. The sampling switch is closed on the 9th rising edge and the device samples the analog input [+IN– (–IN)] and enters the conversion phase on the 16th SCLK falling edge.

$\overline{CS}$  can be pulled high at any time after this. The BUSY signal goes high to indicate the conversion is in progress and continues to be high until the end of conversion. A new frame can be started with the end of conversion.



**Figure 2. Device Operation With DSP Interface**

### POWERDOWN/RESET

A low level on the  $\overline{PWD/RST}$  pin puts the device in the powerdown phase. This is an asynchronous signal. As shown in Figure 4, the device is in the reset phase for the first  $t_{w3}$  period after the falling edge of  $\overline{PWD/RST}$ . SDO goes to three-state for a period of  $t_{d7}$  after the falling edge of  $\overline{PWD/RST}$ . The device powers down if the  $\overline{PWD/RST}$  pin continues to be low for a time period of more than  $t_{w4}$ . Data is not valid for the first four conversions after powerup (see Figure 3) or the end of reset (see Figure 4). The device is initialized during the first four conversions.

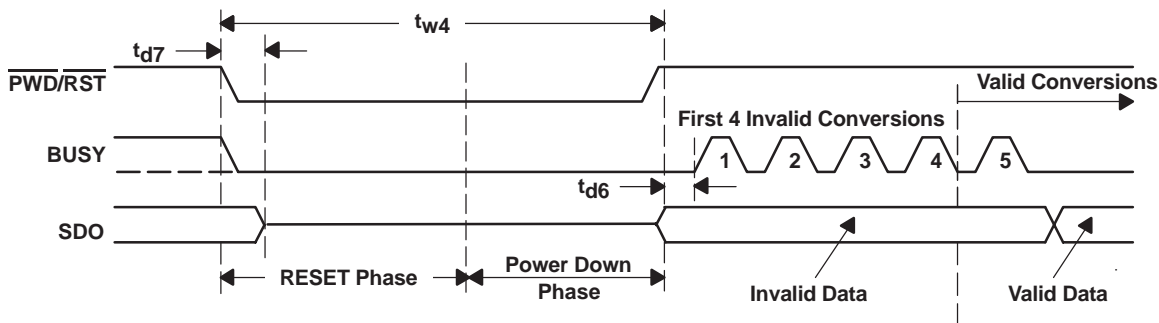

Figure 3. Device Power Down

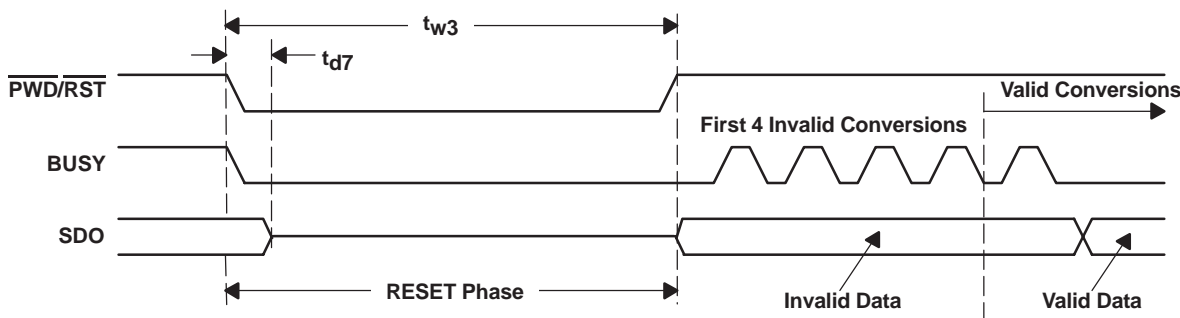

Figure 4. Device Reset

**FRAME ABORT**

A frame can be aborted at any time. There are three phases in the frame, data frame before sample start (first 8 clocks), sample phase (9th rising edge to the 16th falling edge of SCLK), and the conversion phase. The following sections describe a frame abort during each of these phases, for both SPI and DSP interfaces.

**FRAME ABORT IN SPI INTERFACE MODE (FS Held High)**

The rising edge of  $\overline{CS}$  after a frame start (falling edge of  $\overline{CS}$ ) before the 9th rising edge of SCLK aborts a frame (see Figure 5). SDO goes to three-state with  $\overline{CS}$  high. A new frame is started with the falling edge of  $\overline{CS}$ . Previous conversion results are available on SDO during the new frame.

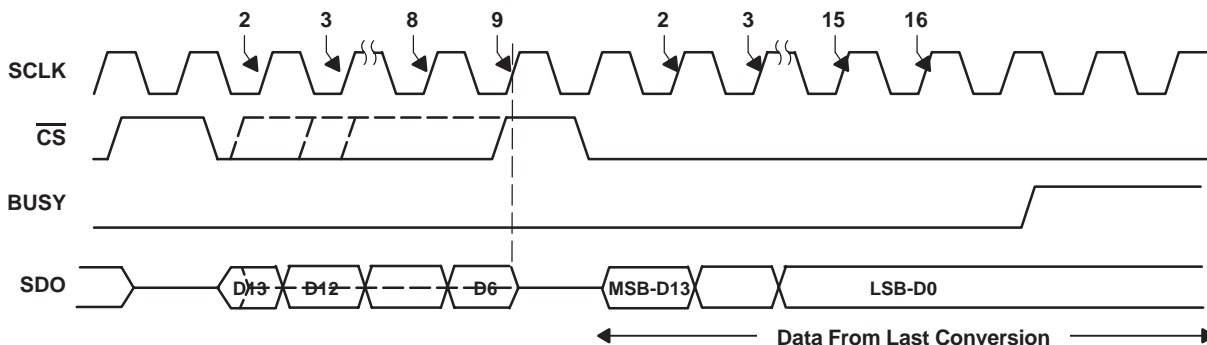

Figure 5. Frame Abort Before Sample Start

A  $\overline{CS}$  rising edge during the sample period ( $t_{d8}$  after the 9th rising edge of SCLK to the 16th falling edge of SCLK) aborts the sample and the device enters the conversion phase. As expected, SDO goes to three-state with  $\overline{CS}$  high. The conversion results can be latched in the next frame, however reliability of the data depends on the sampling time available before the frame abort.

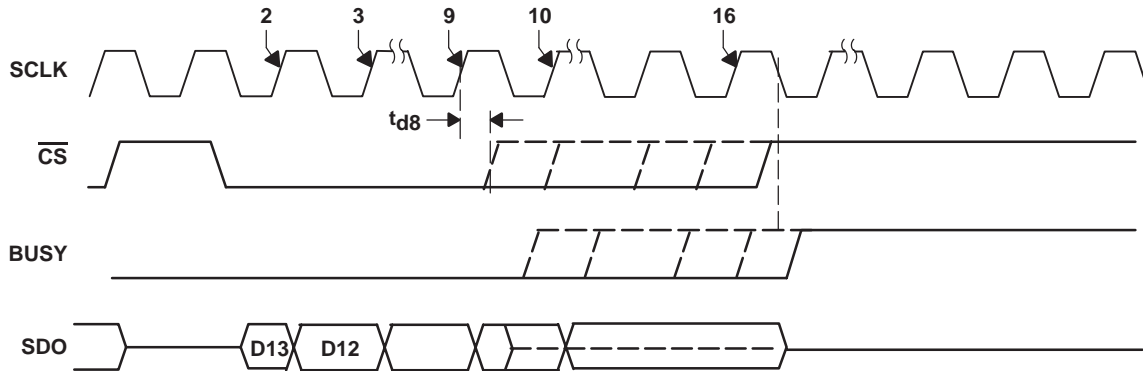

Figure 6. Frame Abort During Sample

The falling edge of  $\overline{CS}$  during a conversion (from BUSY high until the end of  $t_{(CONV)}$  as shown in Figure 7) aborts the ongoing conversion. This starts the next frame. The device outputs 3F80 (hex) on SDO during the first frame after the conversion abort.

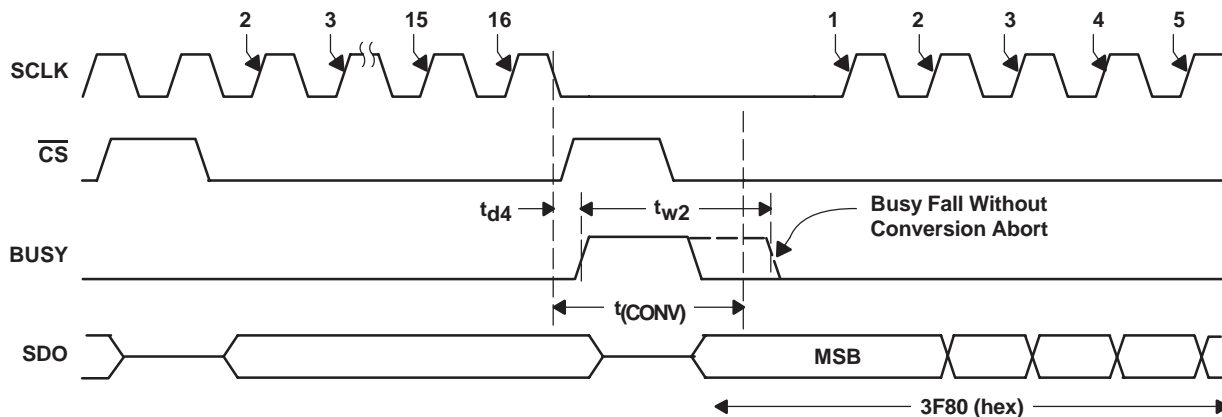

Figure 7. Frame Abort During Conversion

**FRAME ABORT IN DSP INTERFACE MODE**

The rising edge of FS (see Figure 8) or the rising edge of  $\overline{CS}$  (see Figure 9) after the falling edge of FS and before the 9th rising edge of SCLK aborts the frame. SDO goes to three-state with  $\overline{CS}$  high and a new frame is started with the rising edge of FS (see Figure 8 and Figure 9). Previous conversion results are available on SDO during the new frame.

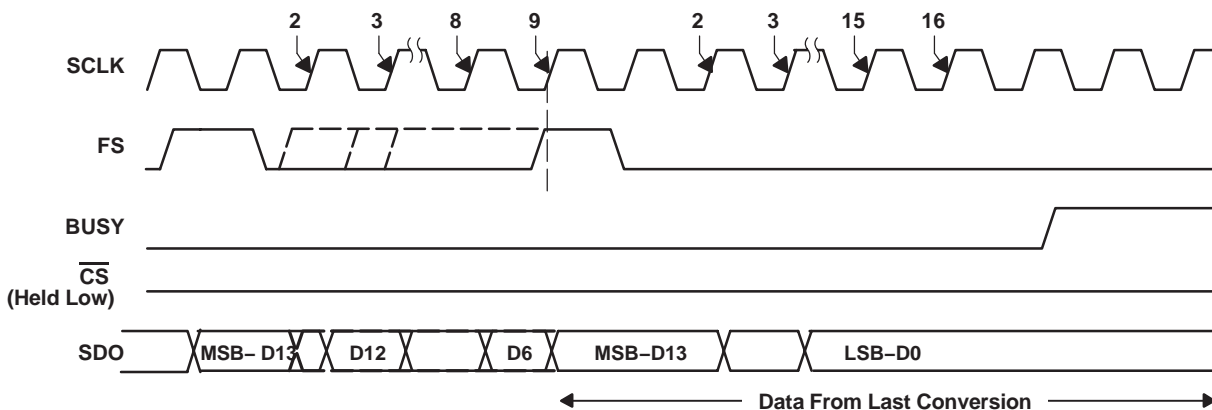

Figure 8. Frame Abort Using FS Before Sample Start

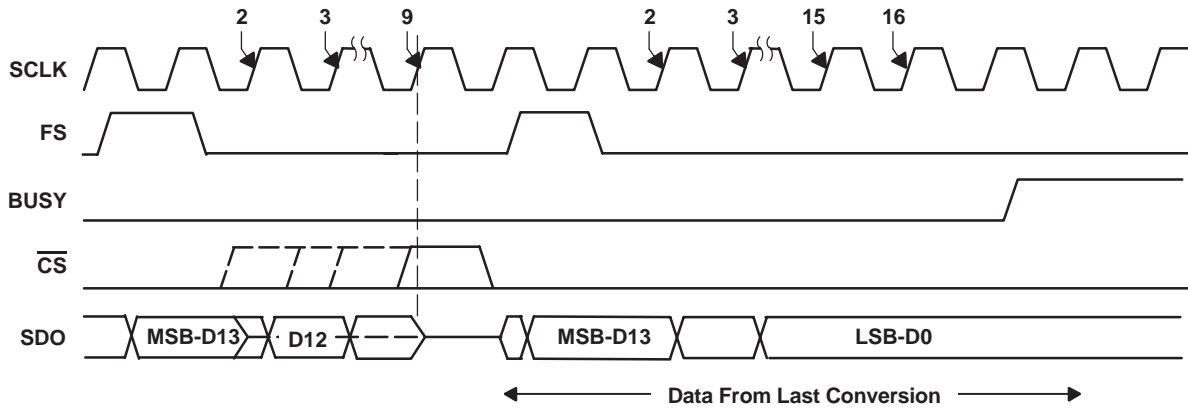

Figure 9. Frame Abort Using  $\overline{CS}$  Before Sample Start

The rising edge of FS (see Figure 10) or rising edge of  $\overline{CS}$  (see Figure 11) during a sample period ( $t_{d8}$  after the 9th rising edge of SCLK) to the 16th falling edge of SCLK aborts the sample and the device enters the conversion phase, this also aborts the current data out operation on SDO (if aborted before 14th clock). As expected, SDO goes to three-state with  $\overline{CS}$  high. The conversion results can be latched in the next frame, however reliability of the data depends on the sampling time available before the frame abort.

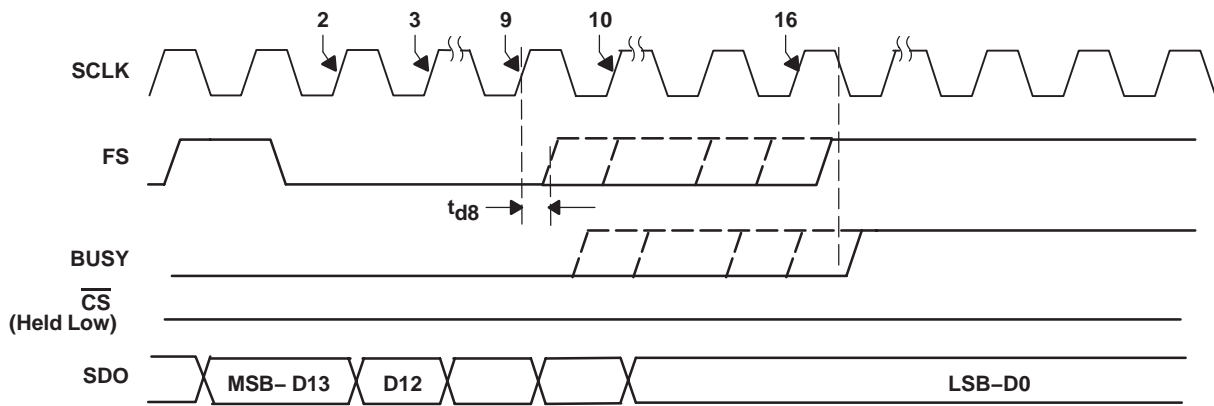

Figure 10. Frame Abort Using FS During Sample

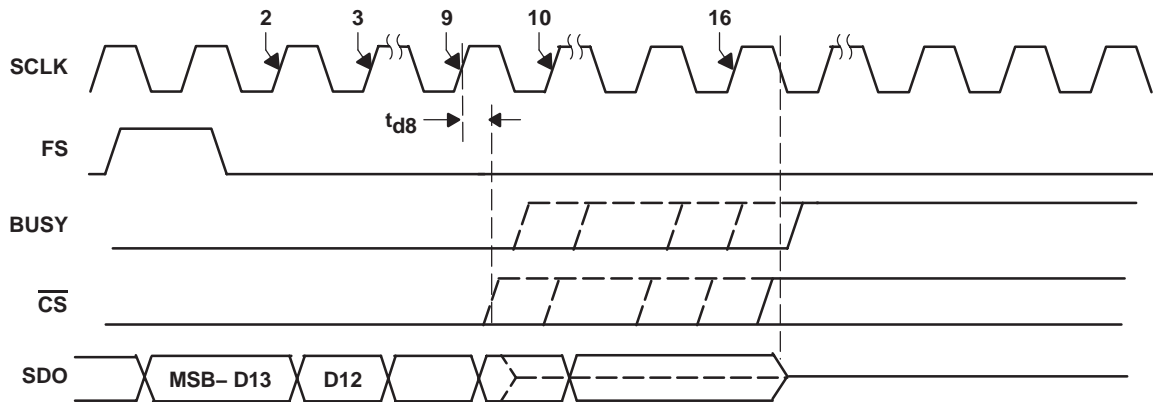

Figure 11. Frame Abort Using  $\overline{CS}$  During Sample

The rising edge of FS during a conversion (from BUSY high until the end of  $t_{(CONV)}$  as shown in Figure 12) aborts the ongoing conversion. This starts the next frame. The device outputs 3F80 (hex) on SDO during the first frame after the conversion abort. Toggling  $\overline{CS}$  during a conversion (with FS low) does not have any effect on the conversion.

# ADS7890

SLAS409 – DECEMBER 2003

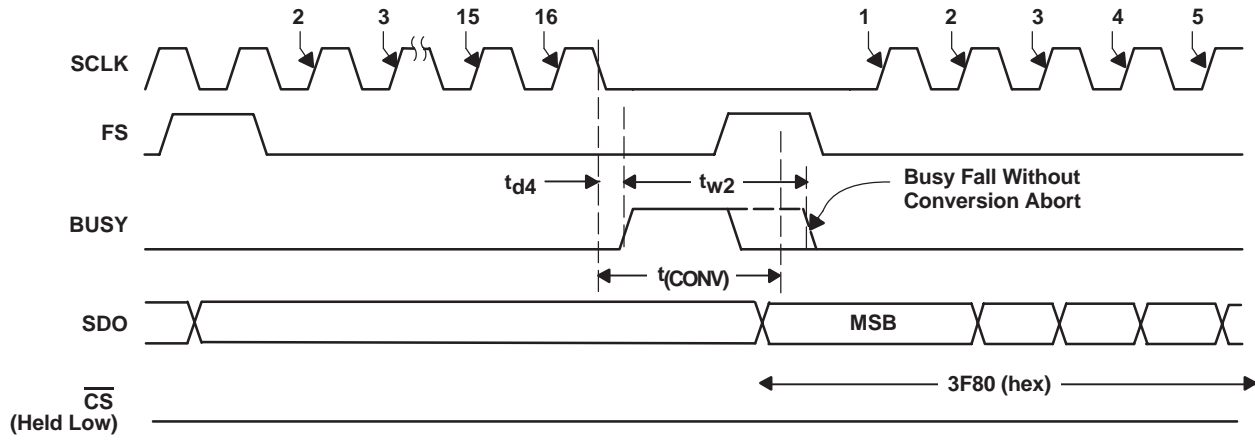

Figure 12. Frame Abort During Conversion

TYPICAL CHARACTERISTICS(1)

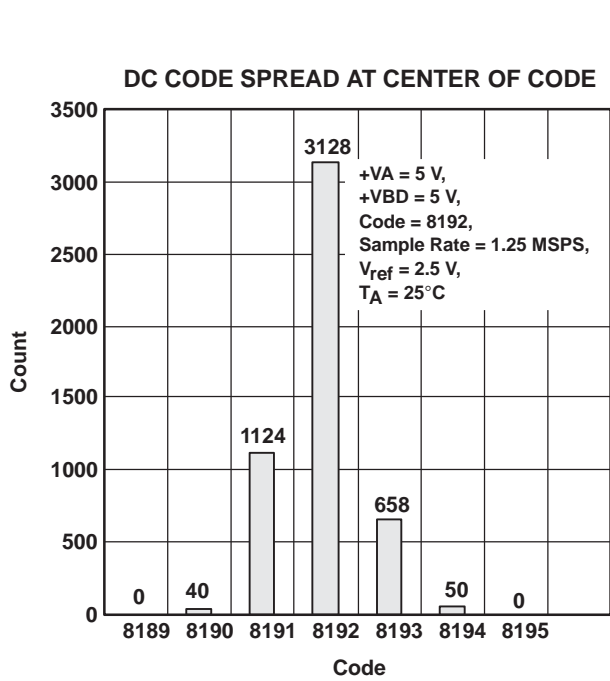

Figure 13

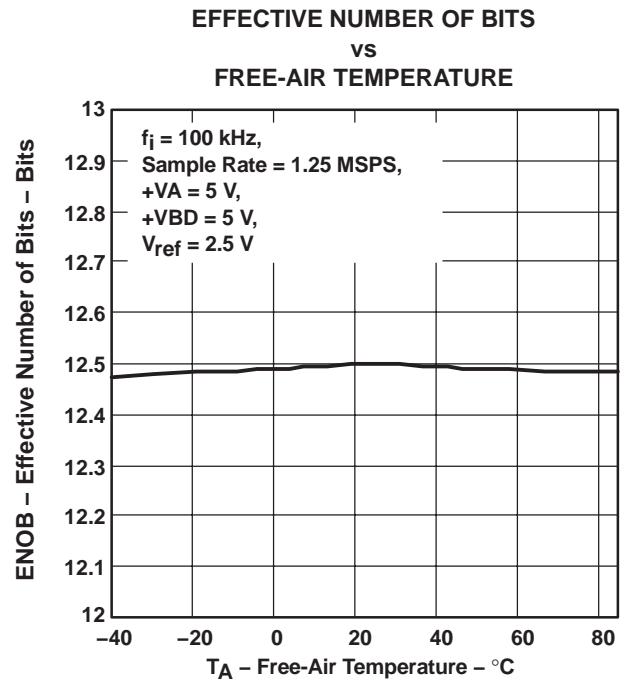

Figure 14

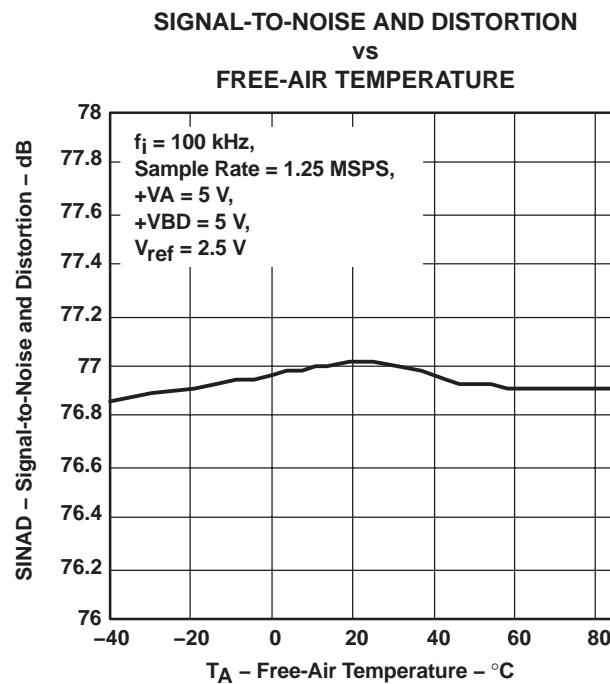

Figure 15

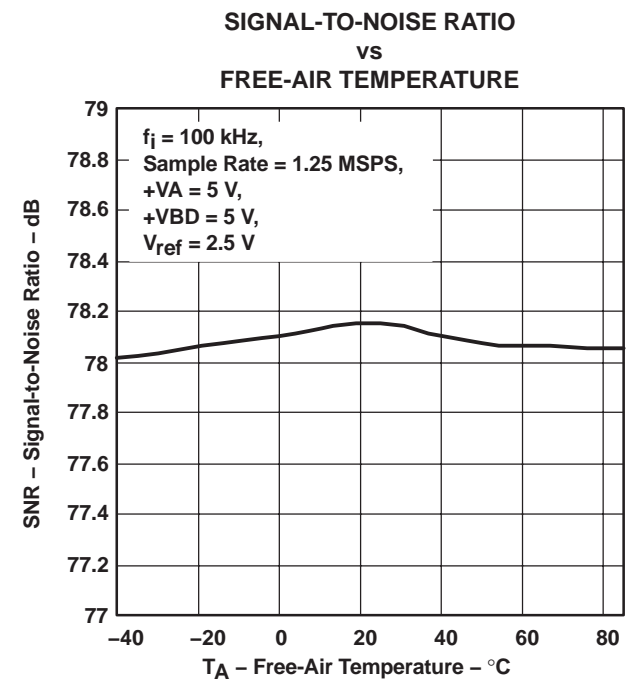

Figure 16

(1) V<sub>ref</sub> = 2.5 V external, unless otherwise specified.

SPURIOUS FREE DYNAMIC RANGE  
vs  
FREE-AIR TEMPERATURE

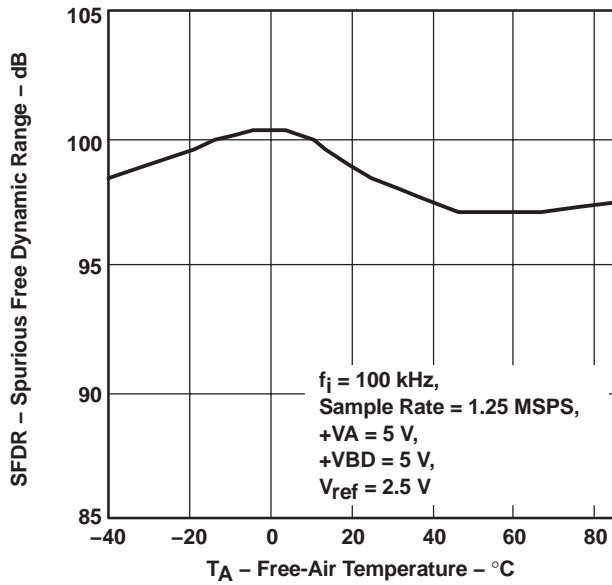

Figure 17

TOTAL HARMONIC DISTORTION  
vs  
FREE-AIR TEMPERATURE

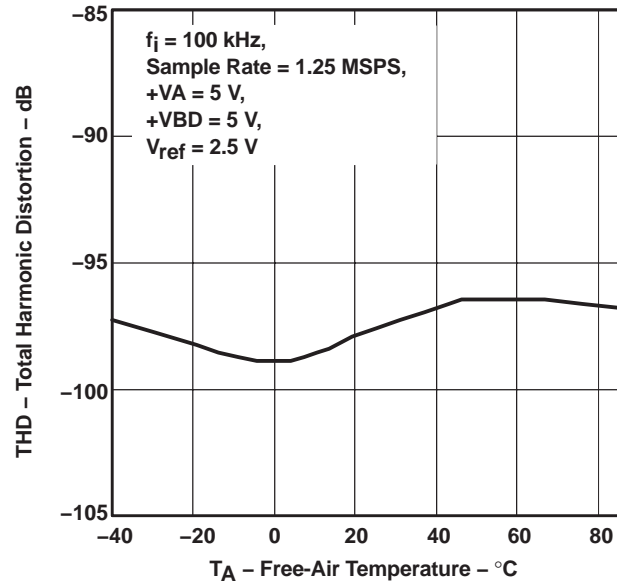

Figure 18

EFFECTIVE NUMBER OF BITS  
vs  
INPUT FREQUENCY

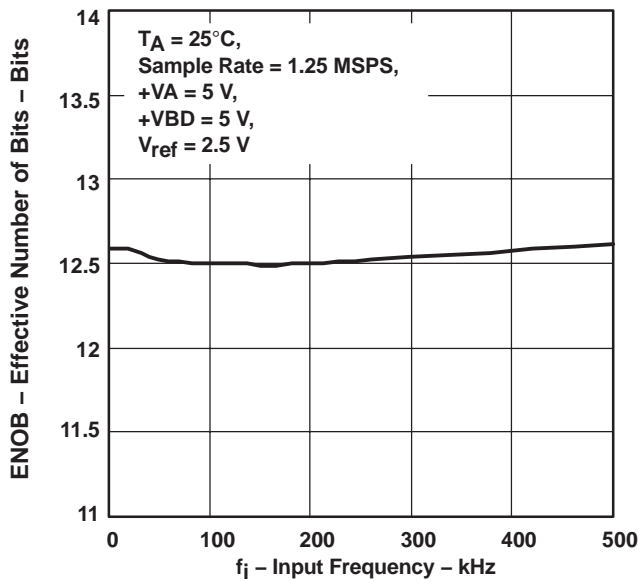

Figure 19

SIGNAL-TO-NOISE AND DISTORTION  
vs  
INPUT FREQUENCY

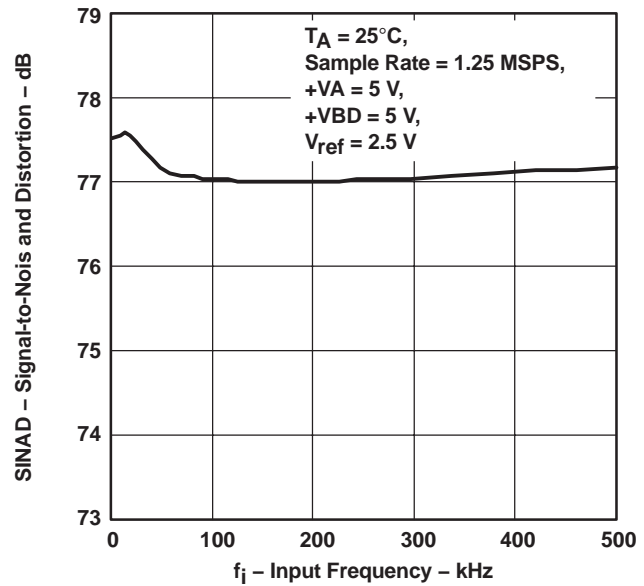

Figure 20

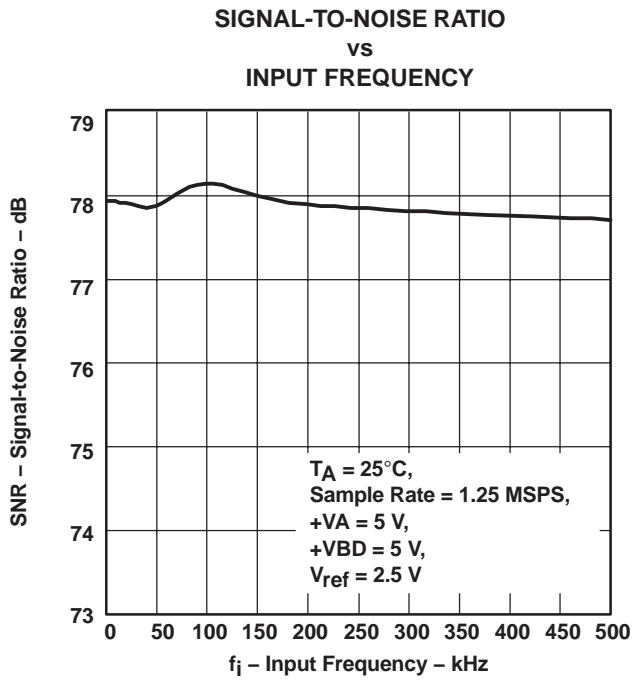

Figure 21

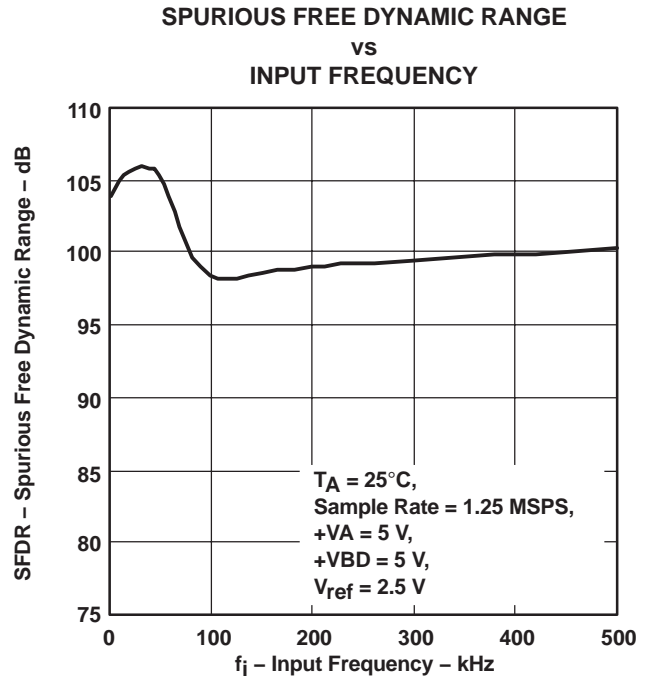

Figure 22

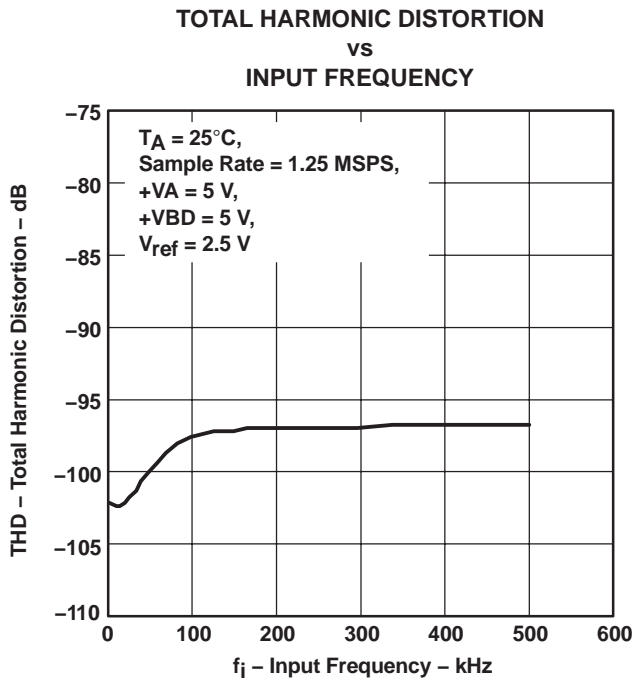

Figure 23

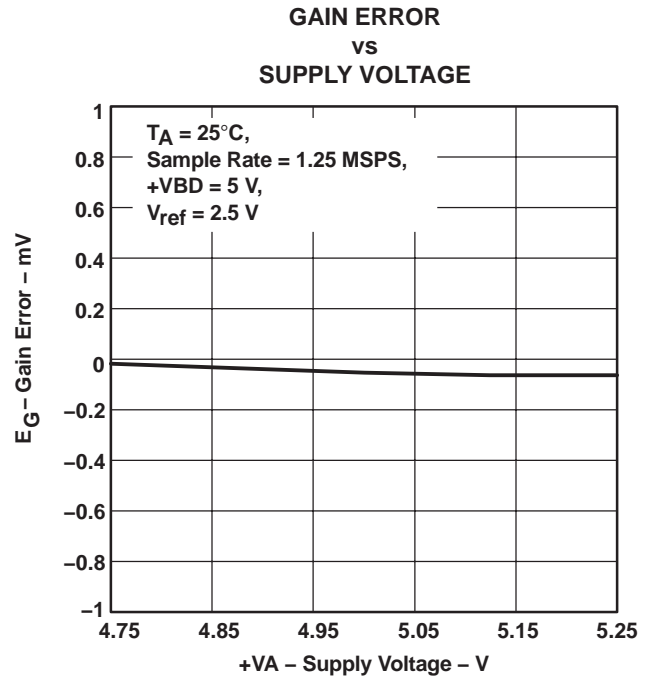
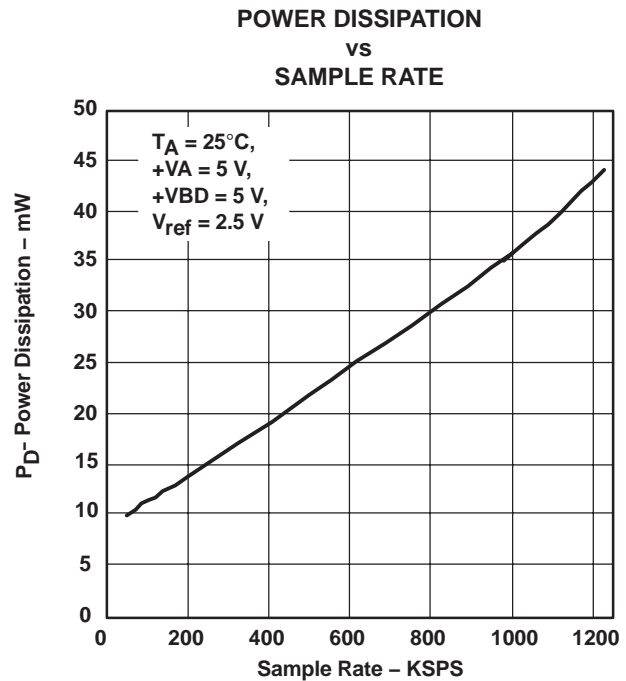
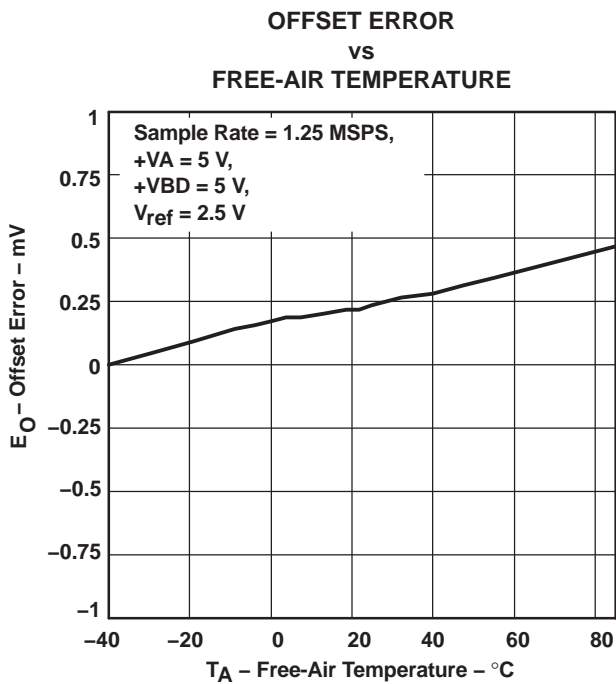
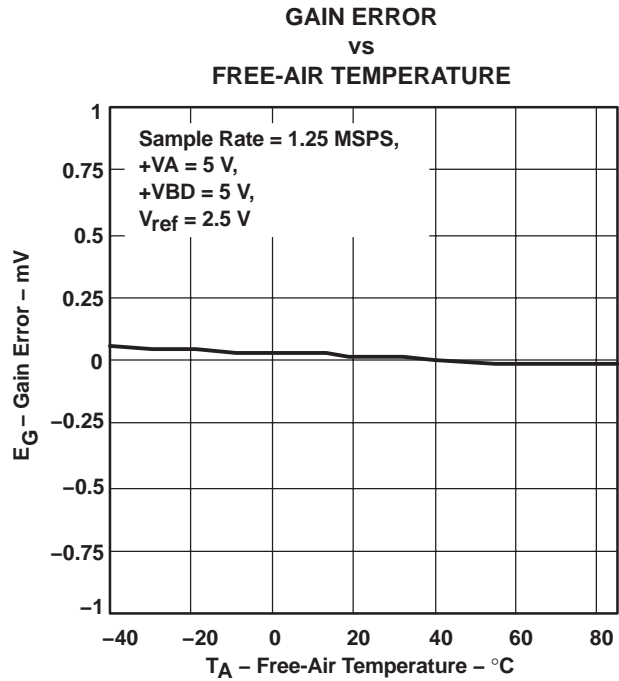
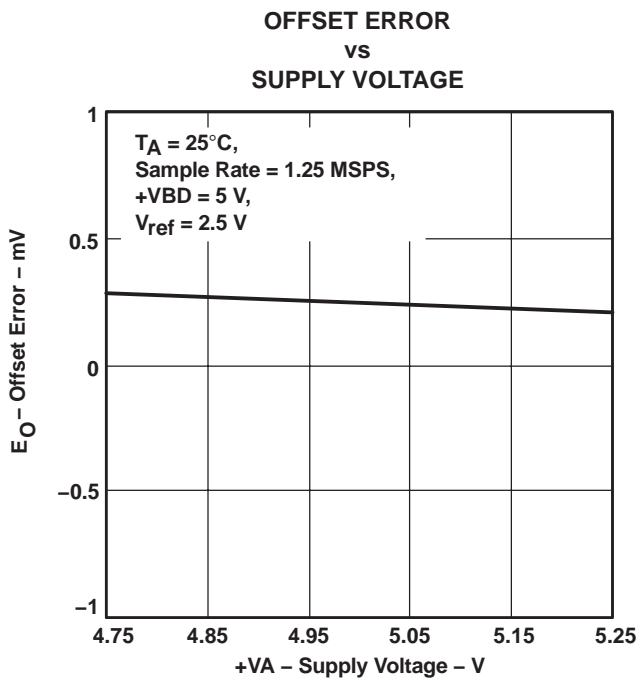
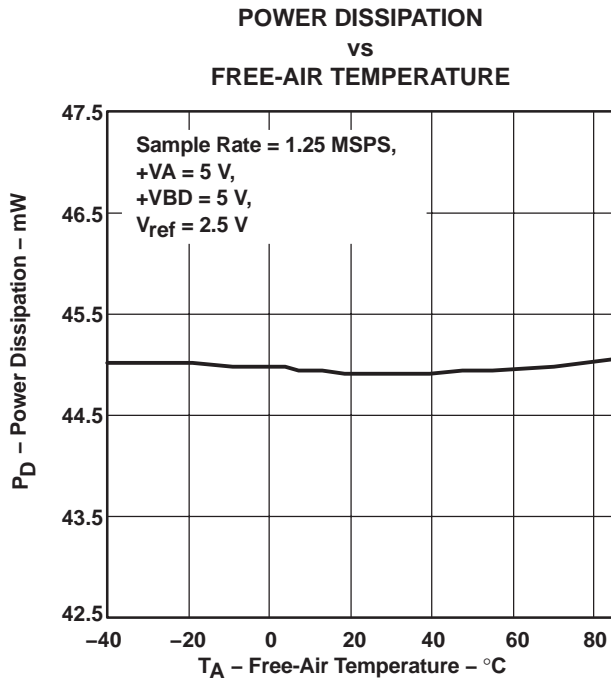
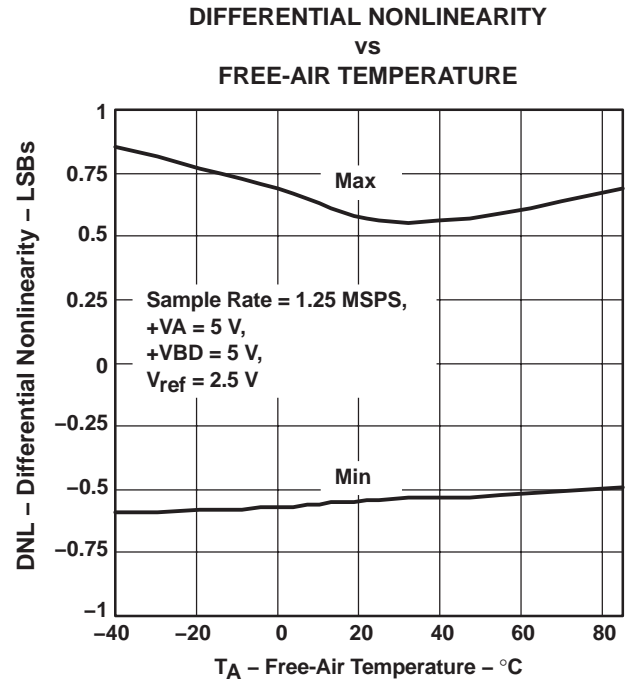

Figure 24

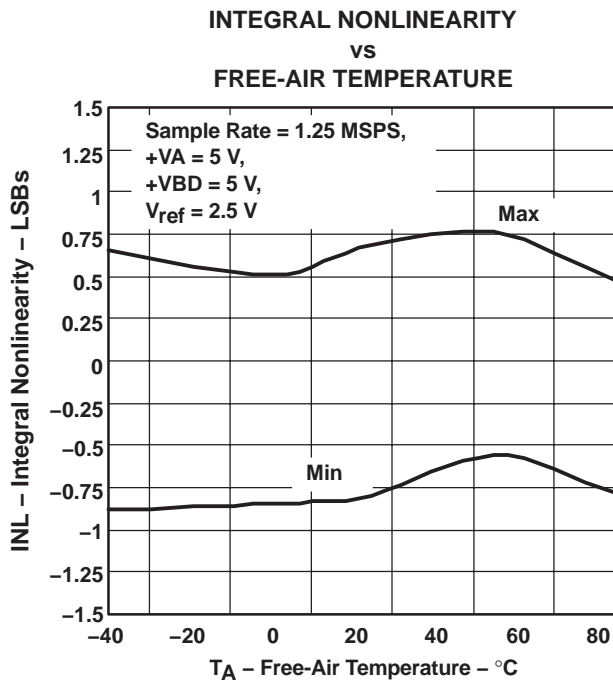



**Figure 29**



**Figure 30**



**Figure 31**

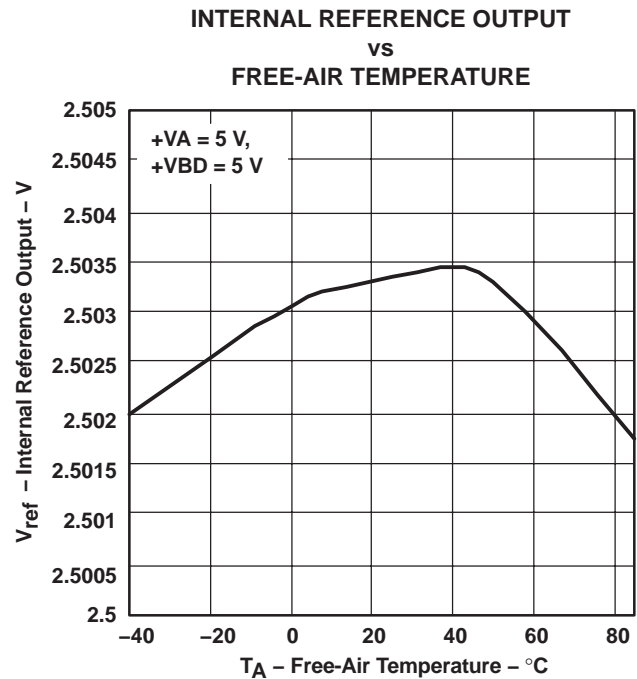

**Figure 32**

INTERNAL REFERENCE OUTPUT  
VS  
SUPPLY VOLTAGE

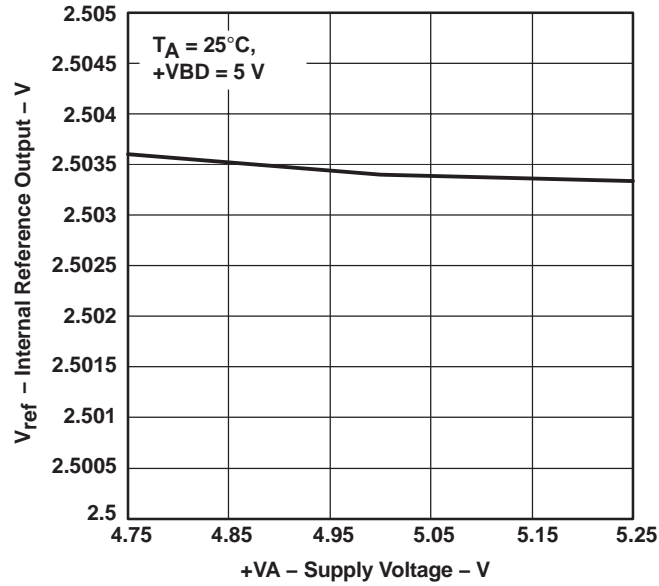

Figure 33

DIFFERENTIAL NONLINEARITY

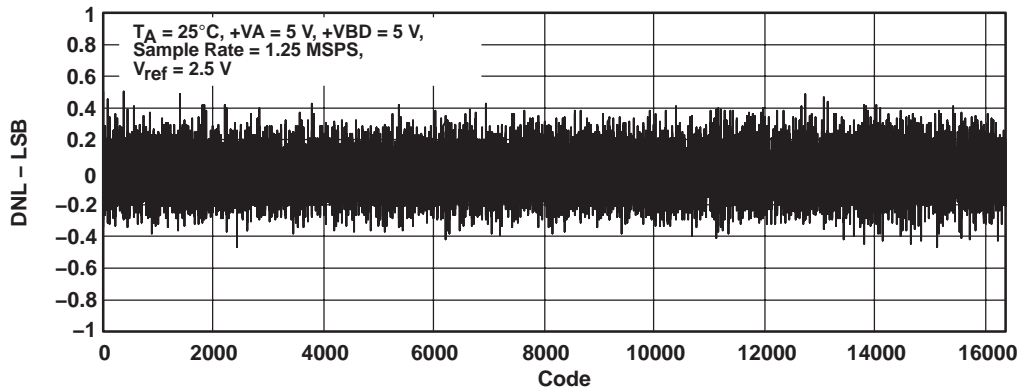

Figure 34

INTEGRAL NONLINEARITY

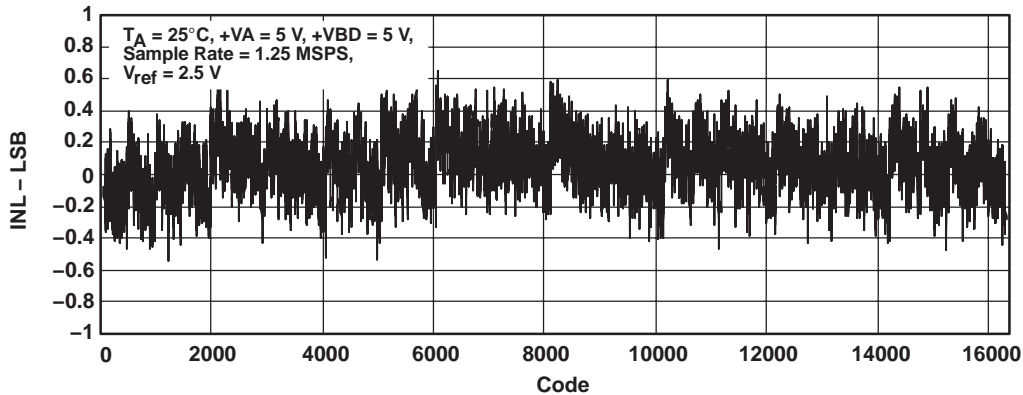

Figure 35

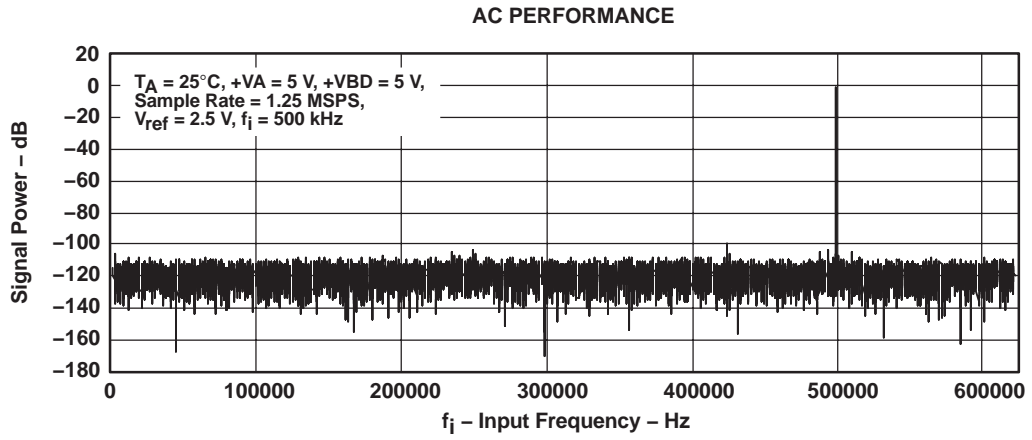

Figure 36

## PRINCIPLES OF OPERATION

The ADS7890 is a member of a family of high-speed successive approximation register (SAR) analog-to-digital converters (ADC). The architecture is based on charge redistribution, which inherently includes a sample/hold function.

The conversion clock is generated internally. The conversion time is 365 ns max (at 5 V +VBD).

The analog input is provided to two input pins: +IN and –IN. (Note that this is pseudo differential input and there are restrictions on –IN voltage range.) When a conversion is initiated, the difference voltage between these pins is sampled on the internal capacitor array. While a conversion is in progress, both inputs are disconnected from any internal function.

## REFERENCE

The ADS7890 has a built-in 2.5-V (nominal value) reference but can operate with an external reference. When an internal reference is used, pin 2 (REFOUT) should be connected to pin 1 (REFIN) with an 0.1- $\mu$ F decoupling capacitor and a 1- $\mu$ F storage capacitor between pin 2 (REFOUT) and pins 47 and 48 (REFM). The internal reference of the converter is buffered. There is also a buffer from REFIN to CDAC. This buffer provides isolation between the external reference and the CDAC and also recharges the CDAC during conversion. It is essential to decouple REFOUT to AGND with a 0.1- $\mu$ F capacitor while the device operates with an external reference.

## ANALOG INPUT

When the converter enters hold mode, the voltage difference between the +IN and –IN inputs is captured on the internal capacitor array. The voltage on the –IN input is limited to between –0.2 V and 0.2 V, thus allowing the input to reject a small signal which is common to both the +IN and –IN inputs. The +IN input has a range of –0.2 V to (+V<sub>ref</sub> +0.2 V). The input span (+IN – (–IN)) is limited from 0 V to VREF.

The input current on the analog inputs depends upon a number of factors: sample rate, input voltage, signal frequency, and source impedance. Essentially, the current into the ADS7890 charges the internal capacitor array during the sample period. After this capacitance has been fully charged, there is no further input current (this may not happen when a signal is moving continuously). The source of the analog input voltage must be able to charge the input capacitance (27 pF) to better than a 14-bit settling level with a step input within the acquisition time of the device. The step size can be selected equal to the maximum voltage difference between two consecutive samples at the maximum signal frequency. (Refer to Figure 39 for the suggested input circuit.) When the converter goes into hold mode, the input impedance is greater than 1 G $\Omega$ .

Care must be taken regarding the absolute analog input voltage. To maintain the linearity of the converter, both –IN and +IN inputs should be within the limits specified. Outside of these ranges, the converter's linearity may not meet specifications.

Care should be taken to ensure that +IN and –IN see the same impedance to the respective sources. (For example, both +IN and –IN are connected to a decoupling capacitor through a 21- $\Omega$  resistor as shown in Figure 39.) If this is not observed, the two inputs could have different settling times. This may result in an offset error, gain error, or linearity error which changes with temperature and input voltage.

## RECOMMENDED OPERATIONAL AMPLIFIERS

It is recommended to use the THS4031 or THS4211 for the analog input. All of the performance figures in this data sheet are measured using the THS4031. Refer to Figure 39 for more information.

## DIGITAL INTERFACE

The device can operate in SPI or DSP interface mode. A busy signal is available to indicate a conversion is in progress apart from  $\overline{CS}$ , SCLK in SPI and  $\overline{CS}$ , SCLK, and FS in DSP mode.

## TIMING AND CONTROL

Refer to the DEVICE OPERATION IN SPI INTERFACE, DEVICE OPERATION IN DSP INTERFACE and FRAME ABORT in the DESCRIPTION AND TIMING sections.

## READING DATA

The ADS7890 outputs serial data in straight binary format as listed in Table 1. Also refer to Figure 1 and Figure 2 for more details.

**Table 1. Ideal Input Voltages and Output Codes<sup>(1)</sup>**

DESCRIPTION	ANALOG VALUE	BINARY CODE	HEX CODE
Full scale	$V_{ref} - 1 \text{ LSB}$	11 1111 1111 1111	3FFF
Midscale	$V_{ref}/2$	10 0000 0000 0000	2000
Midscale – 1 LSB	$V_{ref}/2 - 1 \text{ LSB}$	01 1111 1111 1111	1FFF
Zero	0 V	00 0000 0000 0000	000

<sup>(1)</sup> Full-scale range =  $V_{ref}$  and least significant bit (LSB) =  $V_{ref}/16384$

## Reset

Refer to the POWERDOWN/RESET section for the device reset sequence.

It is recommended to reset the device after power on. A reset can be issued once the power has reached 95% of its final value.

$\overline{\text{PWD/RST}}$  is an asynchronous active low input signal. A current conversion is aborted no later than 45 ns after the converter is in the reset mode. In addition, the device output SDO goes to three-state. The converter returns back to normal operation mode immediately after the  $\overline{\text{PWD/RST}}$  input is brought high.

Data is not valid for the first four conversions after a device reset.

## Powerdown

Refer to the POWERDOWN/RESET section for the device powerdown sequence.

The device enters powerdown mode if a  $\overline{\text{PWD/RST}}$  low duration is extended for more than a period of  $t_{w4}$ .

The converter goes back to normal operation mode no later than a period of  $t_{d6}$  after the  $\overline{\text{PWD/RST}}$  input is brought high.

After this period, normal conversion and sampling operation can be started as discussed in previous sections. Data is not valid for the first four conversions after a device reset.

## Nap Mode

The device enters nap mode at the end of every conversion (with BUSY falling edge). The device powers up again on the 8th SDO rising edge in the next frame. Refer to Figure 1 and Figure 2 for more information. The power dissipation during nap mode is 10 mW. This offers power savings when the device is operated at lower throughput. Refer to Figure 28 for more information on power saving.

## APPLICATION INFORMATION

### LAYOUT

For optimum performance, care should be taken with the physical layout of the ADS7890 circuitry.

As the ADS7890 offers single-supply operation, it is often used in close proximity with digital logic, micro-controllers, microprocessors, and digital signal processors. The more digital logic present in the design and the higher the switching speed, the more difficult it is to achieve acceptable performance from the converter.

The basic SAR architecture is sensitive to glitches or sudden changes on the power supply, reference, ground connections, and digital inputs that occur just prior to the end of sampling (close to the 16th SCLK falling edge) and just prior to latching the output of the analog comparator during the conversion phase. Thus, driving any single conversion for an n-bit SAR converter, there are n+1 windows in which large external transient voltages can affect the conversion result. Such glitches might originate from switching power supplies, nearby digital logic, or high power devices.

The degree of error in the digital output depends on the reference voltage, layout, and the exact timing of the external event.

On average, the ADS7890 draws very little current from an external reference as the reference voltage is internally buffered. If the reference voltage is external and originates from an op amp, make sure that it can drive the bypass capacitor or capacitors without oscillation. A 0.1- $\mu\text{F}$  bypass capacitor and 1- $\mu\text{F}$  storage capacitor are recommended from REFIN (pin 1) directly to REFM (pin 48).

The AGND and BDGND pins should be connected to a clean ground point. In all cases, this should be the analog ground. Avoid connections which are too close to the grounding point of a micro-controller or digital signal processor. If required, run a ground trace directly from the converter to the power supply entry point. The ideal layout consists of an analog ground plane dedicated to the converter and associated analog circuitry.

As with the AGND connections, +VA should be connected to a 5-V power supply plane that is separate from the connection for +VBD and digital logic until they are connected at the power entry point onto the PCB. Power to the ADS7890 should be clean and well bypassed. A 0.1- $\mu\text{F}$  ceramic bypass capacitor should be placed as close to the device as possible. See Table 2 for the placement of capacitor. In addition to a 0.1- $\mu\text{F}$  capacitor, a 1- $\mu\text{F}$  capacitor is recommended. In some situations, additional bypassing may be required, such as a 100- $\mu\text{F}$  electrolytic capacitor or even a Pi filter made up of inductors and capacitors, all designed to essentially low-pass filter the 5-V supply, removing the high frequency noise.

**Table 2. Power Supply Decoupling Capacitor Placement**

POWER SUPPLY PLANE	CONVERTER ANALOG SIDE	CONVERTER DIGITAL SIDE
SUPPLY PINS		
Pairs of pins that require a shortest path to decoupling capacitors	(4,5), (9,8), (10,11), (13, 15), (43, 44) (46, 45)	(24, 25), (34, 35)
Pins that require no decoupling	14, 12	

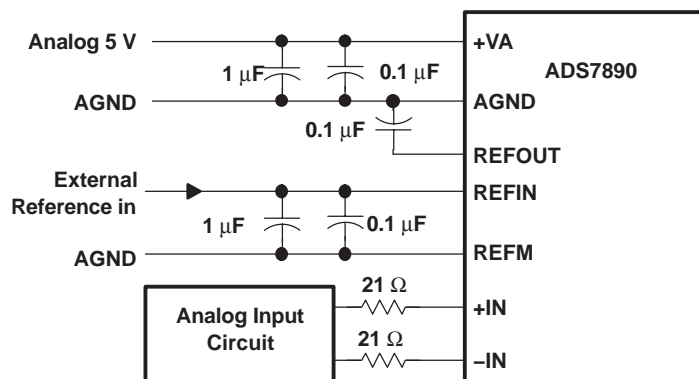

**Figure 37. Using External Reference**

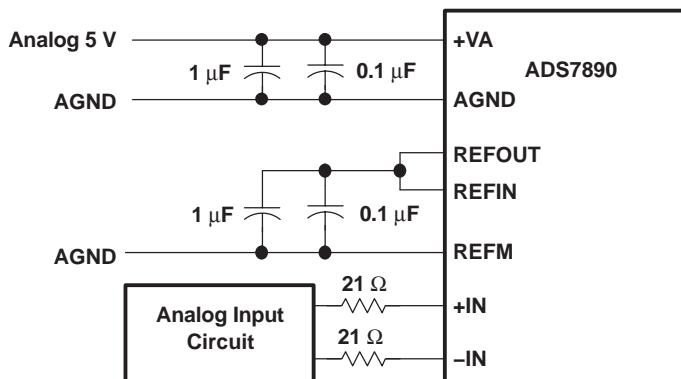

**Figure 38. Using Internal Reference**

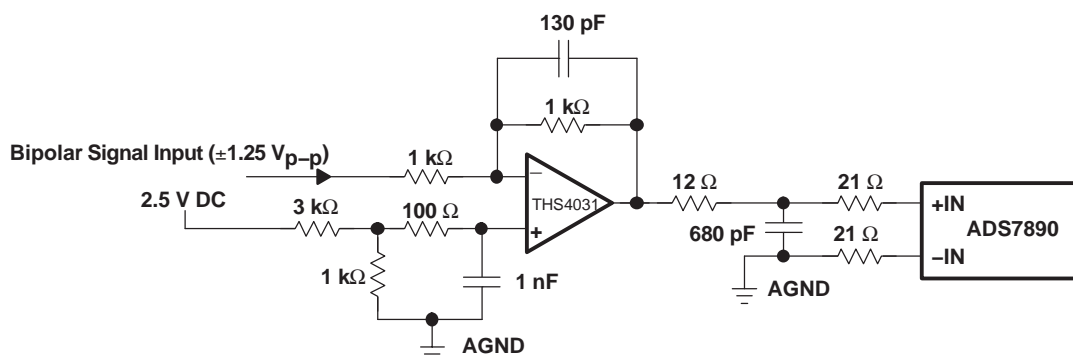

**Figure 39. Typical Analog Input Circuit**

**PACKAGING INFORMATION**

Orderable Device	Status (1)	Package Type	Package Drawing	Pins	Package Qty	Eco Plan (2)	Lead/Ball Finish	MSL Peak Temp (3)	Op Temp (°C)	Top-Side Markings (4)	Samples
ADS7890IPFBT	ACTIVE	TQFP	PFB	48	250	Green (RoHS & no Sb/Br)	CU NIPDAU	Level-2-260C-1 YEAR	-40 to 85	ADS7890I	<a href="#">Samples</a>
ADS7890IPFBTG4	ACTIVE	TQFP	PFB	48	250	Green (RoHS & no Sb/Br)	CU NIPDAU	Level-2-260C-1 YEAR	-40 to 85	ADS7890I	<a href="#">Samples</a>

(1) The marketing status values are defined as follows:

**ACTIVE:** Product device recommended for new designs.

**LIFEBUY:** TI has announced that the device will be discontinued, and a lifetime-buy period is in effect.

**NRND:** Not recommended for new designs. Device is in production to support existing customers, but TI does not recommend using this part in a new design.

**PREVIEW:** Device has been announced but is not in production. Samples may or may not be available.

**OBSOLETE:** TI has discontinued the production of the device.

(2) Eco Plan - The planned eco-friendly classification: Pb-Free (RoHS), Pb-Free (RoHS Exempt), or Green (RoHS & no Sb/Br) - please check <http://www.ti.com/productcontent> for the latest availability information and additional product content details.

**TBD:** The Pb-Free/Green conversion plan has not been defined.

**Pb-Free (RoHS):** TI's terms "Lead-Free" or "Pb-Free" mean semiconductor products that are compatible with the current RoHS requirements for all 6 substances, including the requirement that lead not exceed 0.1% by weight in homogeneous materials. Where designed to be soldered at high temperatures, TI Pb-Free products are suitable for use in specified lead-free processes.

**Pb-Free (RoHS Exempt):** This component has a RoHS exemption for either 1) lead-based flip-chip solder bumps used between the die and package, or 2) lead-based die adhesive used between the die and leadframe. The component is otherwise considered Pb-Free (RoHS compatible) as defined above.

**Green (RoHS & no Sb/Br):** TI defines "Green" to mean Pb-Free (RoHS compatible), and free of Bromine (Br) and Antimony (Sb) based flame retardants (Br or Sb do not exceed 0.1% by weight in homogeneous material)

(3) MSL, Peak Temp. -- The Moisture Sensitivity Level rating according to the JEDEC industry standard classifications, and peak solder temperature.

(4) Multiple Top-Side Markings will be inside parentheses. Only one Top-Side Marking contained in parentheses and separated by a "~" will appear on a device. If a line is indented then it is a continuation of the previous line and the two combined represent the entire Top-Side Marking for that device.

**Important Information and Disclaimer:** The information provided on this page represents TI's knowledge and belief as of the date that it is provided. TI bases its knowledge and belief on information provided by third parties, and makes no representation or warranty as to the accuracy of such information. Efforts are underway to better integrate information from third parties. TI has taken and continues to take reasonable steps to provide representative and accurate information but may not have conducted destructive testing or chemical analysis on incoming materials and chemicals. TI and TI suppliers consider certain information to be proprietary, and thus CAS numbers and other limited information may not be available for release.

In no event shall TI's liability arising out of such information exceed the total purchase price of the TI part(s) at issue in this document sold by TI to Customer on an annual basis.

## TAPE AND REEL INFORMATION



### QUADRANT ASSIGNMENTS FOR PIN 1 ORIENTATION IN TAPE



\*All dimensions are nominal

Device	Package Type	Package Drawing	Pins	SPQ	Reel Diameter (mm)	Reel Width W1 (mm)	A0 (mm)	B0 (mm)	K0 (mm)	P1 (mm)	W (mm)	Pin1 Quadrant
ADS7890IPFBT	TQFP	PFB	48	250	180.0	16.4	9.6	9.6	1.5	12.0	16.0	Q2

**TAPE AND REEL BOX DIMENSIONS**

\*All dimensions are nominal

Device	Package Type	Package Drawing	Pins	SPQ	Length (mm)	Width (mm)	Height (mm)
ADS7890IPFBT	TQFP	PFB	48	250	213.0	191.0	55.0

PFB (S-PQFP-G48)

PLASTIC QUAD FLATPACK

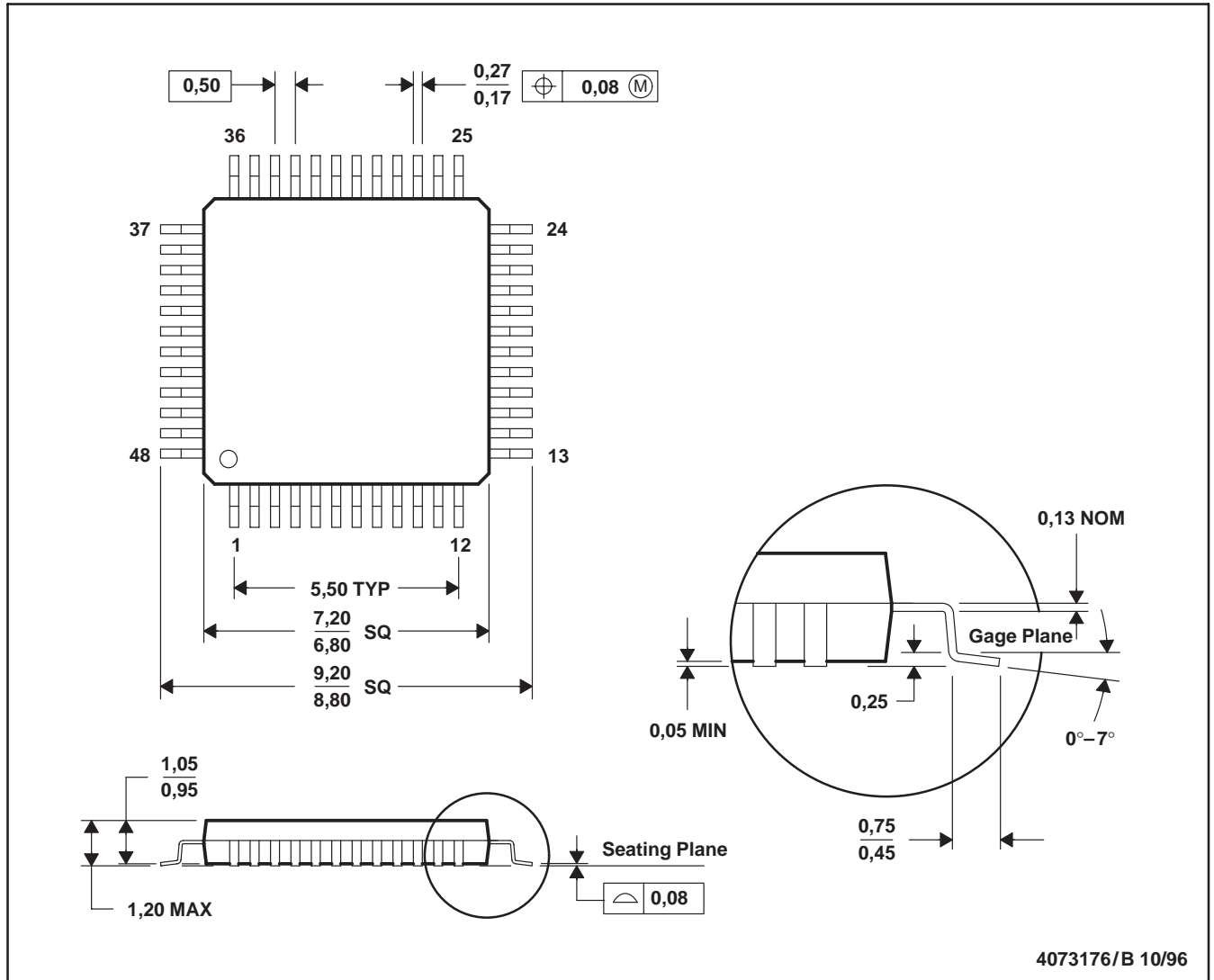

- NOTES: A. All linear dimensions are in millimeters.  
 B. This drawing is subject to change without notice.  
 C. Falls within JEDEC MS-026

PFB (S-PQFP-G48)



4209366/A 03/08

- NOTES:
- A. All linear dimensions are in millimeters.
  - B. This drawing is subject to change without notice.
  - C. Publication IPC-7351 is recommended for alternate designs.
  - D. Laser cutting apertures with trapezoidal walls and also rounding corners will offer better paste release. Customers should contact their board assembly site for stencil design recommendations. Refer to IPC-7525.
  - E. Customers should contact their board fabrication site for solder mask tolerances between and around signal pads.

## IMPORTANT NOTICE

Texas Instruments Incorporated and its subsidiaries (TI) reserve the right to make corrections, enhancements, improvements and other changes to its semiconductor products and services per JESD46, latest issue, and to discontinue any product or service per JESD48, latest issue. Buyers should obtain the latest relevant information before placing orders and should verify that such information is current and complete. All semiconductor products (also referred to herein as "components") are sold subject to TI's terms and conditions of sale supplied at the time of order acknowledgment.

TI warrants performance of its components to the specifications applicable at the time of sale, in accordance with the warranty in TI's terms and conditions of sale of semiconductor products. Testing and other quality control techniques are used to the extent TI deems necessary to support this warranty. Except where mandated by applicable law, testing of all parameters of each component is not necessarily performed.

TI assumes no liability for applications assistance or the design of Buyers' products. Buyers are responsible for their products and applications using TI components. To minimize the risks associated with Buyers' products and applications, Buyers should provide adequate design and operating safeguards.

TI does not warrant or represent that any license, either express or implied, is granted under any patent right, copyright, mask work right, or other intellectual property right relating to any combination, machine, or process in which TI components or services are used. Information published by TI regarding third-party products or services does not constitute a license to use such products or services or a warranty or endorsement thereof. Use of such information may require a license from a third party under the patents or other intellectual property of the third party, or a license from TI under the patents or other intellectual property of TI.

Reproduction of significant portions of TI information in TI data books or data sheets is permissible only if reproduction is without alteration and is accompanied by all associated warranties, conditions, limitations, and notices. TI is not responsible or liable for such altered documentation. Information of third parties may be subject to additional restrictions.

Resale of TI components or services with statements different from or beyond the parameters stated by TI for that component or service voids all express and any implied warranties for the associated TI component or service and is an unfair and deceptive business practice. TI is not responsible or liable for any such statements.

Buyer acknowledges and agrees that it is solely responsible for compliance with all legal, regulatory and safety-related requirements concerning its products, and any use of TI components in its applications, notwithstanding any applications-related information or support that may be provided by TI. Buyer represents and agrees that it has all the necessary expertise to create and implement safeguards which anticipate dangerous consequences of failures, monitor failures and their consequences, lessen the likelihood of failures that might cause harm and take appropriate remedial actions. Buyer will fully indemnify TI and its representatives against any damages arising out of the use of any TI components in safety-critical applications.

In some cases, TI components may be promoted specifically to facilitate safety-related applications. With such components, TI's goal is to help enable customers to design and create their own end-product solutions that meet applicable functional safety standards and requirements. Nonetheless, such components are subject to these terms.

No TI components are authorized for use in FDA Class III (or similar life-critical medical equipment) unless authorized officers of the parties have executed a special agreement specifically governing such use.

Only those TI components which TI has specifically designated as military grade or "enhanced plastic" are designed and intended for use in military/aerospace applications or environments. Buyer acknowledges and agrees that any military or aerospace use of TI components which have **not** been so designated is solely at the Buyer's risk, and that Buyer is solely responsible for compliance with all legal and regulatory requirements in connection with such use.

TI has specifically designated certain components as meeting ISO/TS16949 requirements, mainly for automotive use. In any case of use of non-designated products, TI will not be responsible for any failure to meet ISO/TS16949.

### Products

Audio	<a href="http://www.ti.com/audio">www.ti.com/audio</a>
Amplifiers	<a href="http://amplifier.ti.com">amplifier.ti.com</a>
Data Converters	<a href="http://dataconverter.ti.com">dataconverter.ti.com</a>
DLP® Products	<a href="http://www.dlp.com">www.dlp.com</a>
DSP	<a href="http://dsp.ti.com">dsp.ti.com</a>
Clocks and Timers	<a href="http://www.ti.com/clocks">www.ti.com/clocks</a>
Interface	<a href="http://interface.ti.com">interface.ti.com</a>
Logic	<a href="http://logic.ti.com">logic.ti.com</a>
Power Mgmt	<a href="http://power.ti.com">power.ti.com</a>
Microcontrollers	<a href="http://microcontroller.ti.com">microcontroller.ti.com</a>
RFID	<a href="http://www.ti-rfid.com">www.ti-rfid.com</a>
OMAP Applications Processors	<a href="http://www.ti.com/omap">www.ti.com/omap</a>
Wireless Connectivity	<a href="http://www.ti.com/wirelessconnectivity">www.ti.com/wirelessconnectivity</a>

### Applications

Automotive and Transportation	<a href="http://www.ti.com/automotive">www.ti.com/automotive</a>
Communications and Telecom	<a href="http://www.ti.com/communications">www.ti.com/communications</a>
Computers and Peripherals	<a href="http://www.ti.com/computers">www.ti.com/computers</a>
Consumer Electronics	<a href="http://www.ti.com/consumer-apps">www.ti.com/consumer-apps</a>
Energy and Lighting	<a href="http://www.ti.com/energy">www.ti.com/energy</a>
Industrial	<a href="http://www.ti.com/industrial">www.ti.com/industrial</a>
Medical	<a href="http://www.ti.com/medical">www.ti.com/medical</a>
Security	<a href="http://www.ti.com/security">www.ti.com/security</a>
Space, Avionics and Defense	<a href="http://www.ti.com/space-avionics-defense">www.ti.com/space-avionics-defense</a>
Video and Imaging	<a href="http://www.ti.com/video">www.ti.com/video</a>

### TI E2E Community

[e2e.ti.com](http://e2e.ti.com)

## Looking for pricing, stock, or lifecycle information?

Click below to explore more details on WIN SOURCE:

 [View ADS7890IPFBT on WIN SOURCE](#)

 [Texas Instruments](#) Information

## Optimize Your Supply Chain with WIN SOURCE Solutions

-  Global Sourcing Solution
-  Obsolete Management
-  Cost Control Management
-  Shortage Management
-  Alternative Solution
-  Excess Inventory Management