



# THE DATASHEET OF ADS802U





# 12-Bit, 10MHz Sampling ANALOG-TO-DIGITAL CONVERTER

## FEATURES

- NO MISSING CODES
- LOW POWER: 250mW
- INTERNAL REFERENCE
- WIDEBAND TRACK-AND-HOLD: 65MHz
- SINGLE +5V SUPPLY

## APPLICATIONS

- IF AND BASEBAND DIGITIZATION
- DATA ACQUISITION CARDS
- TEST INSTRUMENTATION
- CCD IMAGING
  - Copiers
  - Scanners
  - Cameras
- VIDEO DIGITIZING
- GAMMA CAMERAS

## DESCRIPTION

The ADS802 is a low-power, monolithic 12-bit, 10MHz Analog-to-Digital (A/D) converter utilizing a small geometry CMOS process. This complete converter includes a 12-bit quantizer, wideband track-and-hold, reference, and three-state outputs. It operates from a single +5V power supply and can be configured to accept either differential or single-ended input signals.

The ADS802 employs digital error correction in order to provide excellent Nyquist differential linearity performance for demanding imaging applications. Its low distortion, high SNR, and high oversampling capability give it the extra margin needed for telecommunications, test instrumentation, and video applications.

This high-performance A/D converter is specified for AC and DC performance at a 10MHz sampling rate. The ADS802 is available in an SO-28 package.

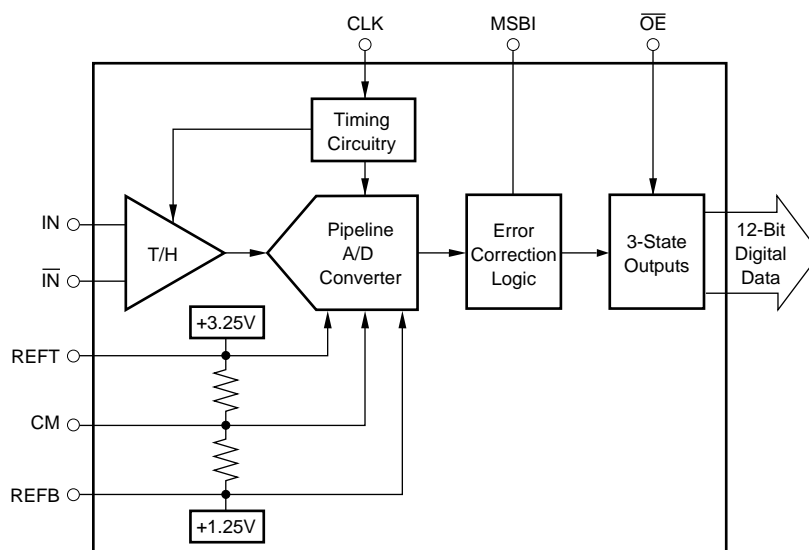

Please be aware that an important notice concerning availability, standard warranty, and use in critical applications of Texas Instruments semiconductor products and disclaimers thereto appears at the end of this data sheet.

All trademarks are the property of their respective owners.

## ABSOLUTE MAXIMUM RATINGS<sup>(1)</sup>

+V <sub>S</sub> .....	+6V
Analog Input .....	0V to (+V <sub>S</sub> + 300mV)
Logic Input .....	0V to (+V <sub>S</sub> + 300mV)
Case Temperature .....	+100°C
Junction Temperature .....	+150°C
Storage Temperature .....	+125°C
External Top Reference Voltage (REFT) .....	+3.4V Max
External Bottom Reference Voltage (REFB) .....	+1.1V Min

NOTE: (1) Stresses above these ratings may permanently damage the device.



## ELECTROSTATIC DISCHARGE SENSITIVITY

This integrated circuit can be damaged by ESD. Texas Instruments recommends that all integrated circuits be handled with appropriate precautions. Failure to observe proper handling and installation procedures can cause damage.

ESD damage can range from subtle performance degradation to complete device failure. Precision integrated circuits may be more susceptible to damage because very small parametric changes could cause the device not to meet its published specifications.

## PACKAGE/ORDERING INFORMATION<sup>(1)</sup>

PRODUCT	PACKAGE-LEAD	PACKAGE DESIGNATOR	SPECIFIED TEMPERATURE RANGE	PACKAGE MARKING	ORDERING NUMBER	TRANSPORT MEDIA, QUANTITY
ADS802U	SO-28	DW	-40°C to +85°C	ADS802U	ADS802U	Rails, 28
ADS802U	"	"	"	ADS802U	ADS802U/1K	Tape and Reel, 1000

NOTE: (1) For the most current package and ordering information, see the Package Option Addendum at the end of this document, or see the TI website at [www.ti.com](http://www.ti.com).

## ELECTRICAL CHARACTERISTICS

At T<sub>A</sub> = +25°C, V<sub>S</sub> = +5V, and Sampling Rate = 10MHz, and with a 50% duty cycle clock having 2ns rise-and-fall time, unless otherwise noted.

PARAMETER	CONDITIONS	TEMP	ADS802U			UNITS
			MIN	TYP	MAX	
<b>RESOLUTION</b> Specified Temperature Range	T <sub>AMBIENT</sub>		-40	12	+85	Bits °C
<b>ANALOG INPUT</b> Differential Full-Scale Input Range Common-Mode Voltage Analog Input Bandwidth (-3dB) Small-Signal Full-Power Input Impedance	Both Inputs  -20dBFS <sup>(1)</sup> Input 0dBFS Input	+25°C +25°C	+1.25	+2.25 400 65 1.25    4	+3.25	V V MHz MHz MΩ    pF
<b>DIGITAL INPUT</b> Logic Family Convert Command	Start Conversion		TTL/HCT Compatible CMOS Falling Edge			
<b>ACCURACY<sup>(2)</sup></b> Gain Error  Gain Tempco Power-Supply Rejection of Gain Input Offset Error Power-Supply Rejection of Offset	f <sub>S</sub> = 2.5MHz  Δ +V <sub>S</sub> = ±5% Δ +V <sub>S</sub> = ±5%	+25°C Full +25°C Full +25°C		±0.6 ±1.0 ±85 0.03 ±2.1 0.05	±1.5 ±2.5 0.1 ±3.0 0.1	% % ppm/°C %FSR/% % %FSR/%
<b>CONVERSION CHARACTERISTICS</b> Sample Rate Data Latency			10k	6.5	10M	Sample/s Convert Cycle
<b>DYNAMIC CHARACTERISTICS</b> Differential Linearity Error f = 500kHz  f = 5MHz  No Missing Codes Integral Linearity Error at f = 500kHz Spurious-Free Dynamic Range (SFDR) f = 500kHz (-1dBFS input)  f = 5MHz (-1dBFS input)	Best Fit	+25°C 0°C to +85°C +25°C 0°C to +85°C 0°C to +85°C  +25°C Full +25°C Full		±0.3 ±0.4 ±0.4 ±0.4 Tested ±1.7  67 66 63 62	±1.0 ±1.0 ±1.0 ±1.0 ±2.75	LSB LSB LSB LSB LSB  dBFS dBFS dBFS dBFS

NOTES: (1) dBFS refers to dB below Full-Scale. (2) Percentage accuracies are referred to the internal A/D converter Full-Scale Range of 4Vp-p. (3) IMD is referred to the larger of the two input signals. If referred to the peak envelope signal (=0dB), the intermodulation products will be 7dB lower. (4) No "rollover" of bits.

# ELECTRICAL CHARACTERISTICS (Cont.)

At  $T_A = +25^\circ\text{C}$ ,  $V_S = +5\text{V}$ , and Sampling Rate = 10MHz, and with a 50% duty cycle clock having a 2ns rise-and-fall time, unless otherwise noted.

PARAMETER	CONDITIONS	TEMP	ADS802U			UNITS
			MIN	TYP	MAX	
<b>DYNAMIC CHARACTERISTICS (Cont.)</b>						
2-Tone Intermodulation Distortion (IMD) <sup>(3)</sup> f = 4.4MHz and 4.5MHz (–7dBFS each tone)		+25°C Full		–65 –64		dBc dBc
Signal-to-Noise Ratio (SNR) f = 500kHz (–1dBFS input)		+25°C Full	65 64	67 67		dB dB
f = 5MHz (–1dBFS input)		+25°C Full	64 62	66 66		dB dB
Signal-to-(Noise + Distortion) (SINAD) f = 500kHz (–1dBFS input)		+25°C Full	63 61	66 65		dB dB
f = 5MHz (–1dBFS input)		+25°C Full	61 60	63 62		dB dB
Differential Gain Error	NTSC or PAL	+25°C		0.5		%
Differential Phase Error	NTSC or PAL	+25°C		0.1		Degrees
Aperture Delay Time		+25°C		2		ns
Aperture Jitter		+25°C		7		ps rms
Over-Voltage Recovery Time <sup>(4)</sup>	1.5x Full-Scale Input	+25°C		2		ns
<b>OUTPUTS</b>						
Logic Family			TTL/HCT Compatible CMOS			
Logic Coding	Logic Selectable		SOB or BTC			
Logic Levels	Logic LOW	Full	0		0.4	V
	Logic HIGH	Full	2.0		+ $V_S$	V
3-State Enable Time		Full		20	40	ns
3-State Disable Time		Full		2	10	ns
<b>POWER-SUPPLY REQUIREMENTS</b>						
Supply Voltage: + $V_S$	Operating	Full	+4.75	+5.0	+5.25	V
Supply Current: + $I_S$	Operating	+25°C		50	62	mA
	Operating	Full		52	62	mA
Power Consumption	Operating	+25°C		250	310	mW
	Operating	Full		260	310	mW
Thermal Resistance, $\theta_{JA}$ SO-28				75		°C/W

NOTES: (1) dBFS refers to dB below Full-Scale. (2) Percentage accuracies are referred to the internal A/D converter Full-Scale Range of 4Vp-p. (3) IMD is referred to the larger of the two input signals. If referred to the peak envelope signal (=0dB), the intermodulation products will be 7dB lower. (4) No “rollover” of bits.

## PIN CONFIGURATION

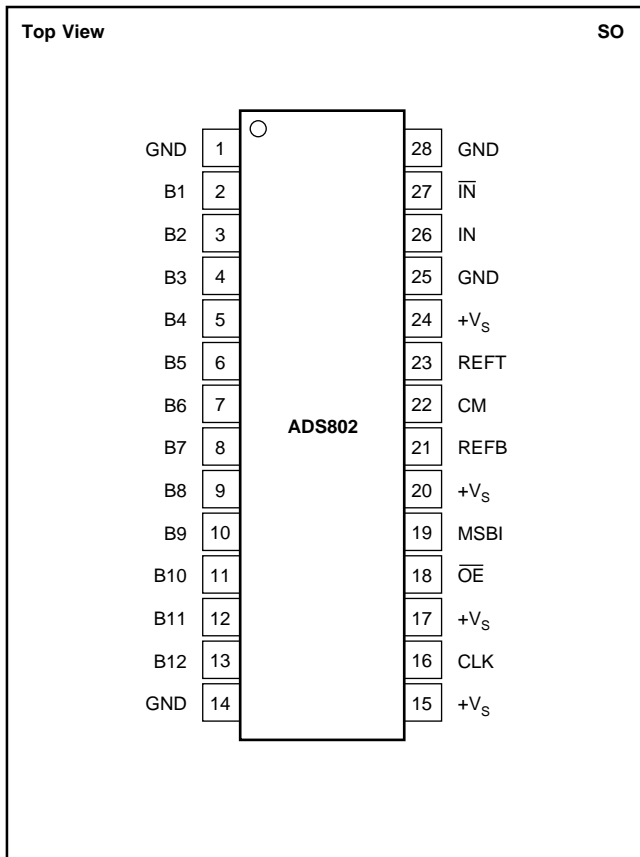

## PIN DESCRIPTIONS

PIN	DESIGNATOR	DESCRIPTION
1	GND	Ground
2	B1	Bit 1, Most Significant Bit (MSB)
3	B2	Bit 2
4	B3	Bit 3
5	B4	Bit 4
6	B5	Bit 5
7	B6	Bit 6
8	B7	Bit 7
9	B8	Bit 8
10	B9	Bit 9
11	B10	Bit 10
12	B11	Bit 11
13	B12	Bit 12, Least Significant Bit (LSB)
14	GND	Ground
15	+V <sub>S</sub>	+5V Power Supply
16	CLK	Convert Clock Input, 50% Duty Cycle
17	+V <sub>S</sub>	+5V Power Supply
18	$\overline{OE}$	HIGH: High-Impedance State. LOW or Floating: Normal Operation. Internal pull-down resistors.
19	MSBI	Most Significant Bit Inversion, HIGH: MSB inverted for complementary output. LOW or Floating: Straight output. Internal pull-down resistors.
20	+V <sub>S</sub>	+5V Power Supply
21	REFB	Bottom Reference Bypass. For external bypassing of internal +1.25V reference.
22	CM	Common-Mode Voltage. It is derived by (REFT + REFB)/2.
23	REFT	Top Reference Bypass. For external bypassing of internal +3.25V reference.
24	+V <sub>S</sub>	+5V Power Supply
25	GND	Ground
26	IN	Input
27	$\overline{IN}$	Complementary Input
28	GND	Ground

## TIMING DIAGRAM

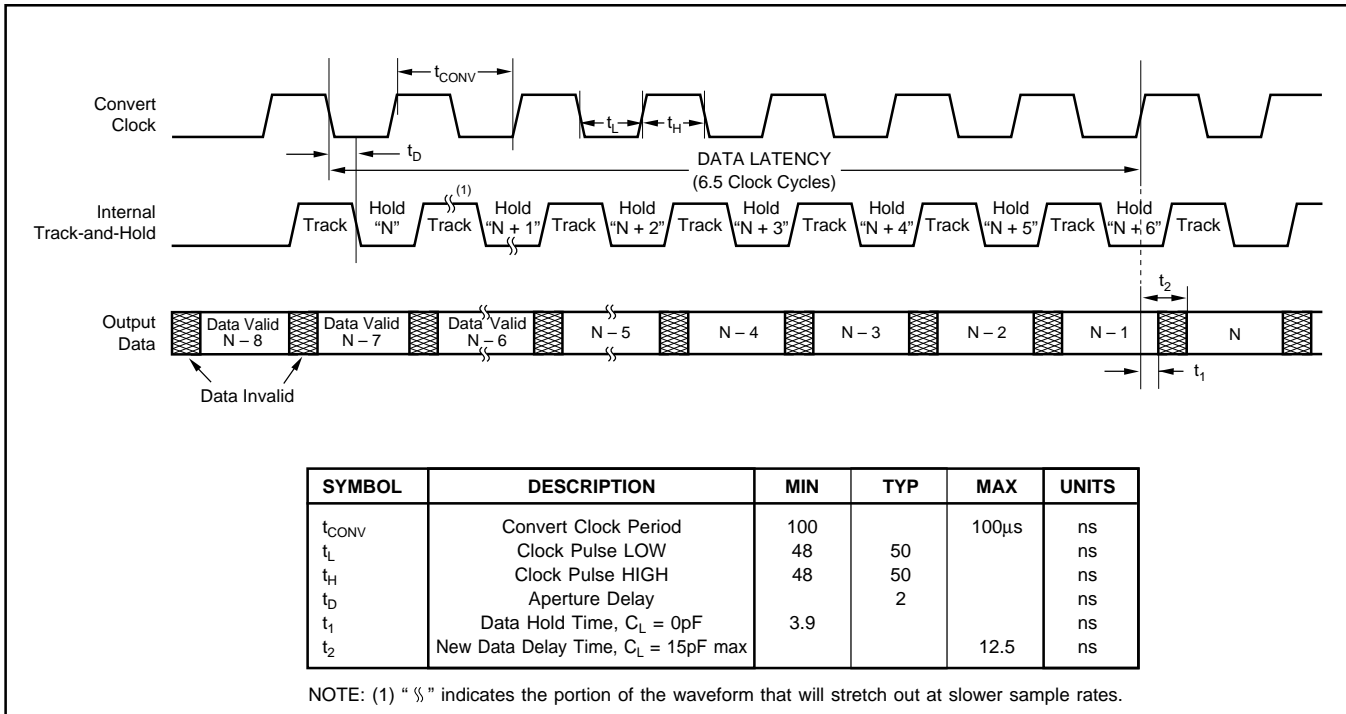

# TYPICAL CHARACTERISTICS

At  $T_A = +25^\circ\text{C}$ ,  $V_S = +5\text{V}$ , Sampling Rate = 10MHz, and with a 50% duty cycle clock having a 2ns rise-and-fall time, unless otherwise noted.

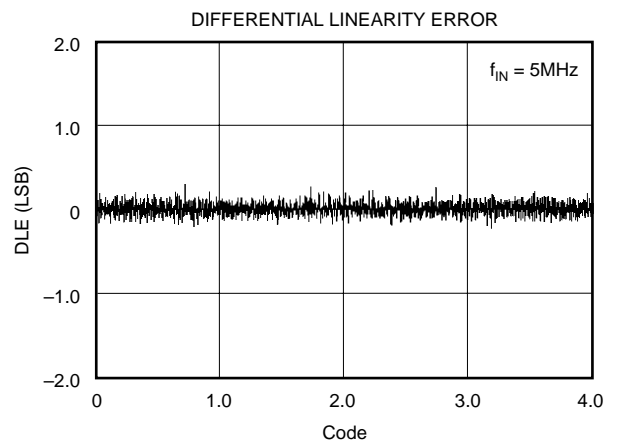
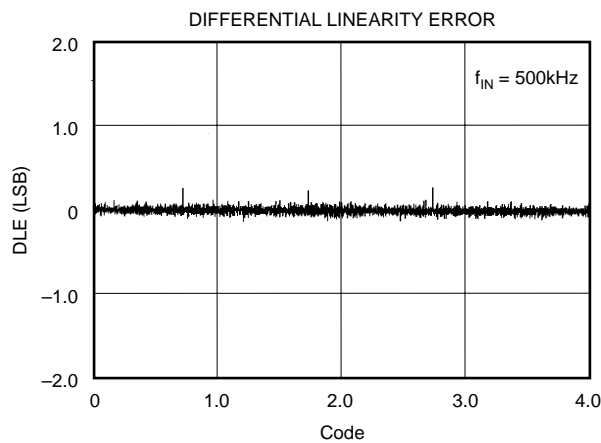
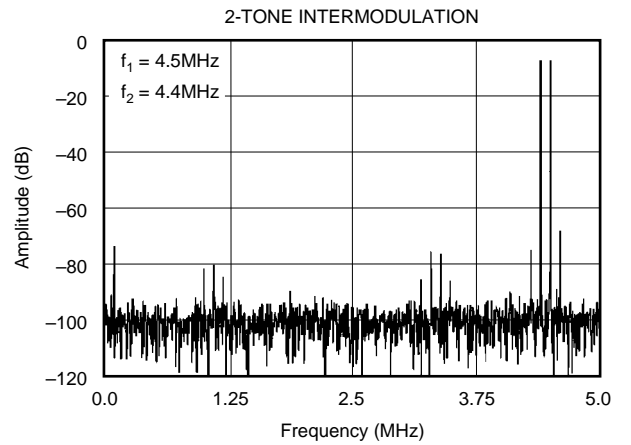
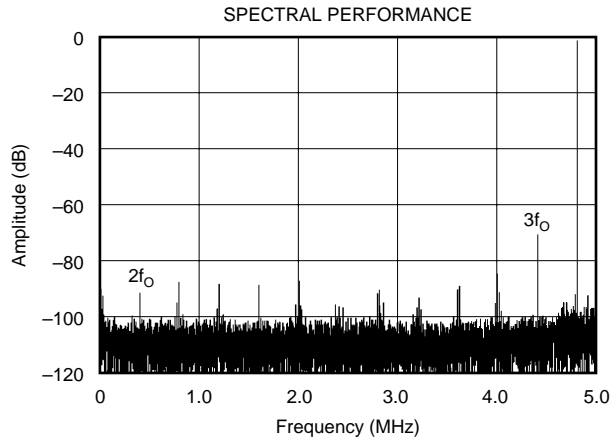
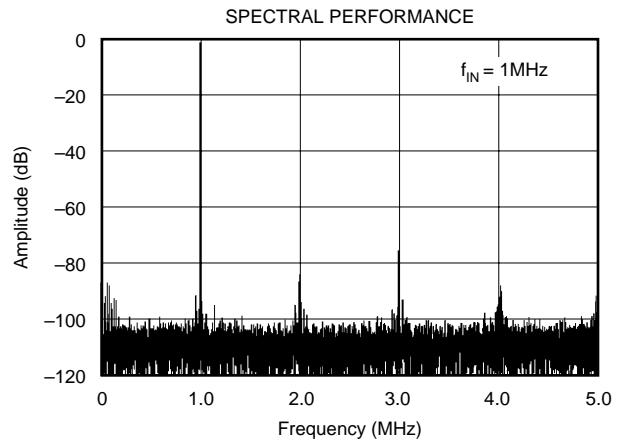
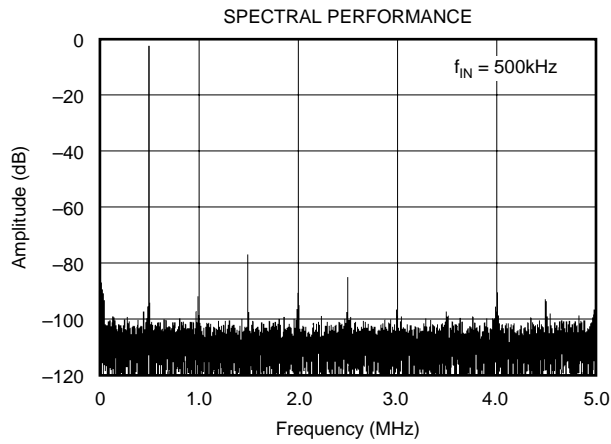

# TYPICAL CHARACTERISTICS (Cont.)

At  $T_A = +25^\circ\text{C}$ ,  $V_S = +5\text{V}$ , Sampling Rate = 10MHz, and with a 50% duty cycle clock having a 2ns rise-and-fall time, unless otherwise noted.

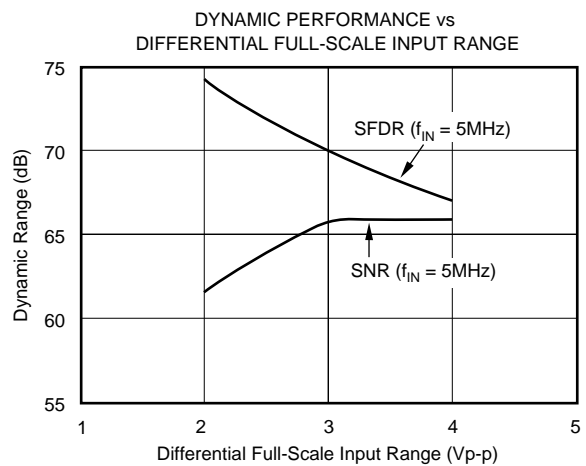
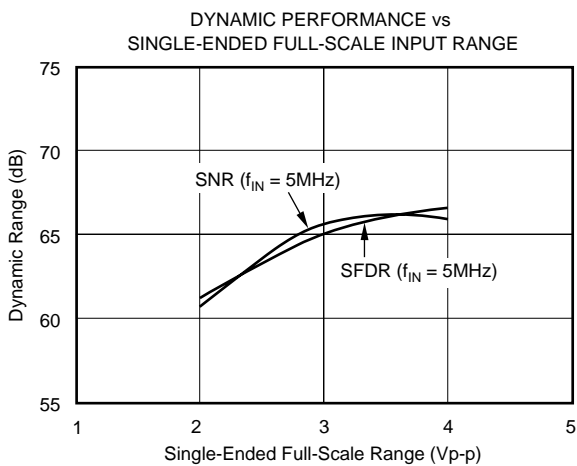
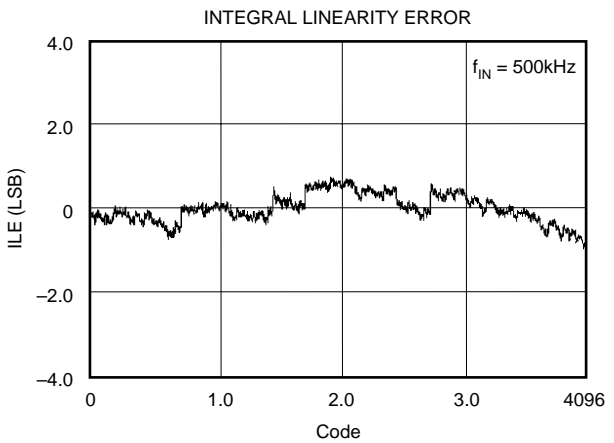
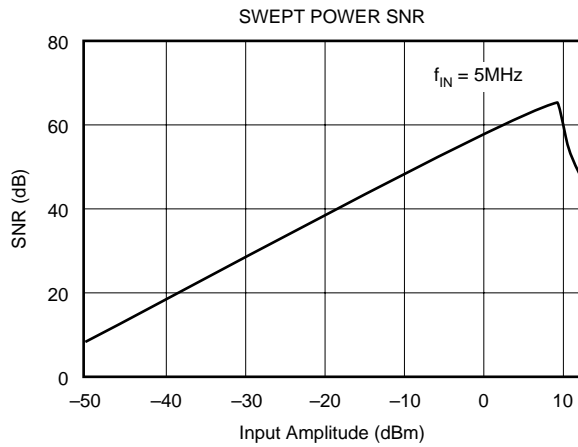
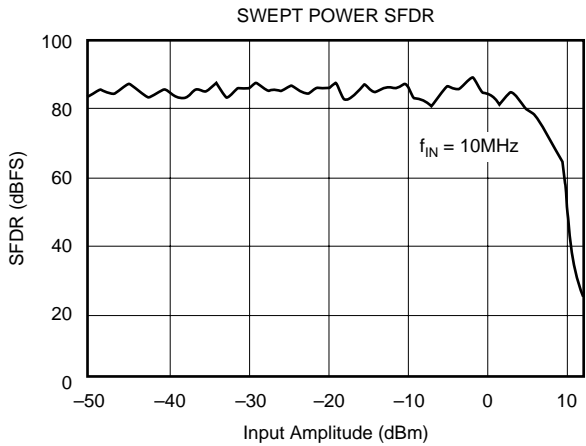
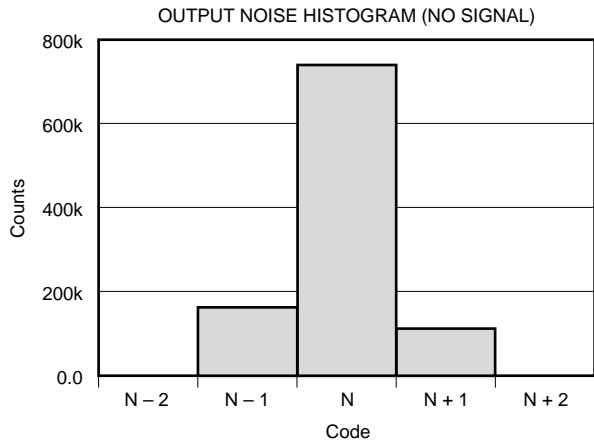

# TYPICAL CHARACTERISTICS (Cont.)

At  $T_A = +25^\circ\text{C}$ ,  $V_S = +5\text{V}$ , Sampling Rate = 10MHz, and with a 50% duty cycle clock having a 2ns rise-and-fall time, unless otherwise noted.

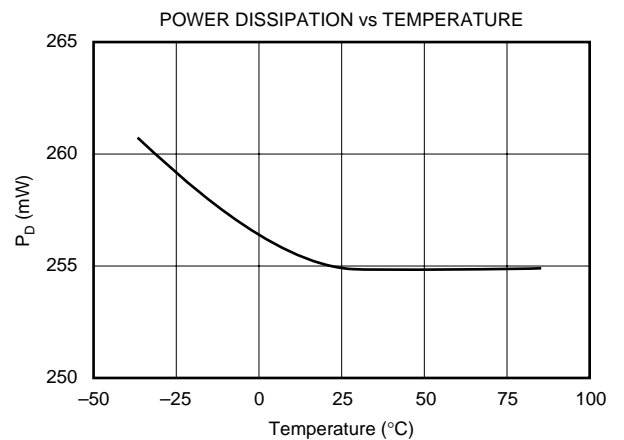
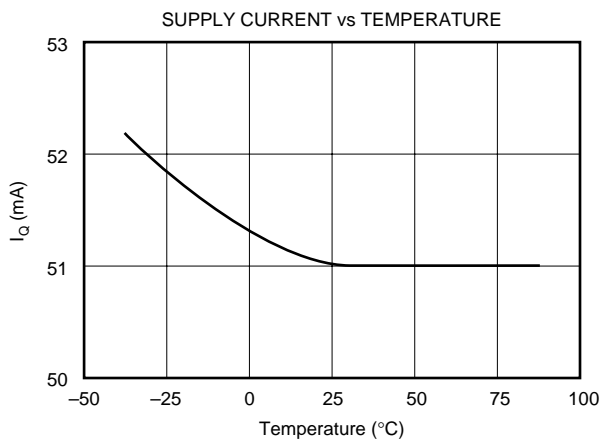
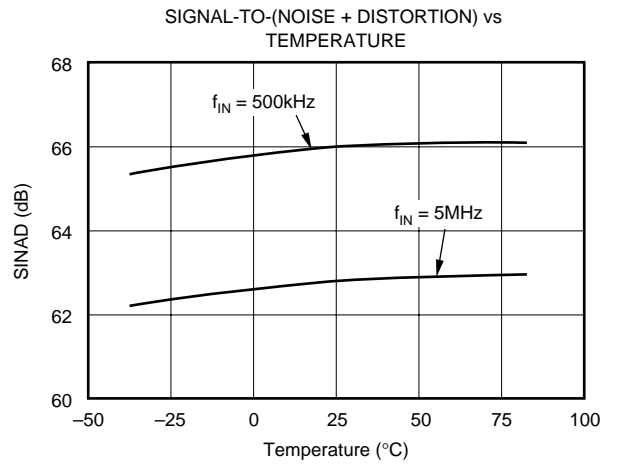
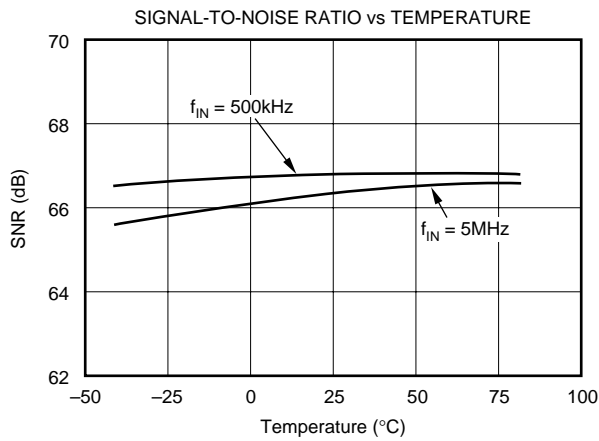
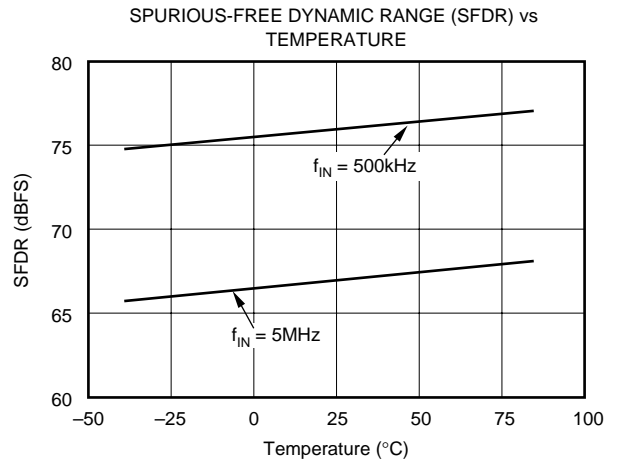
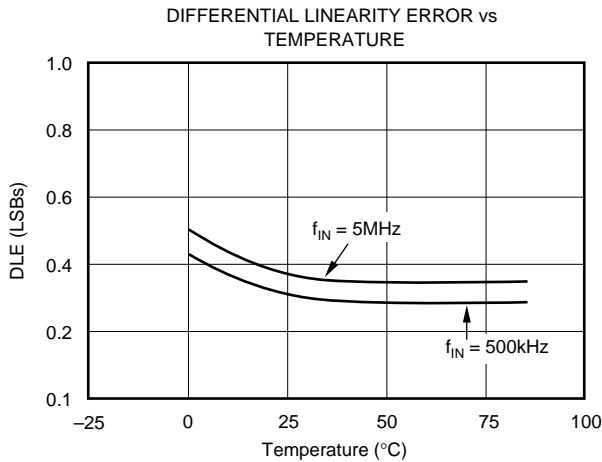

# TYPICAL CHARACTERISTICS (Cont.)

At  $T_A = +25^\circ\text{C}$ ,  $V_S = +5\text{V}$ , Sampling Rate = 10MHz, and with a 50% duty cycle clock having a 2ns rise-and-fall time, unless otherwise noted.

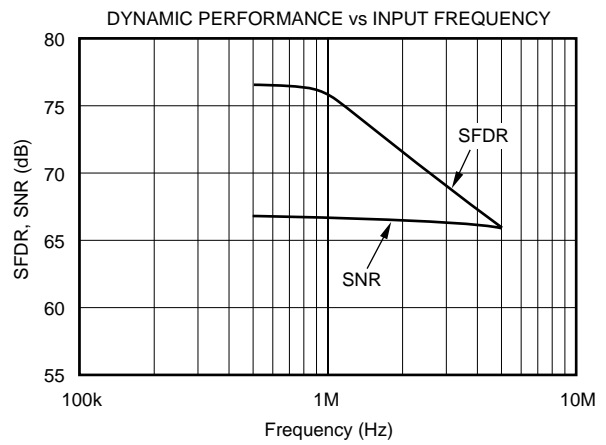
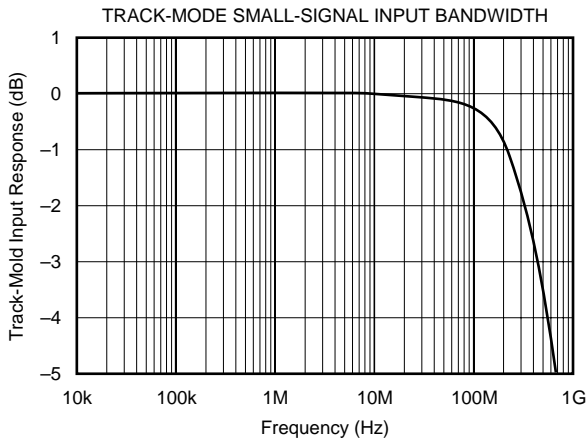
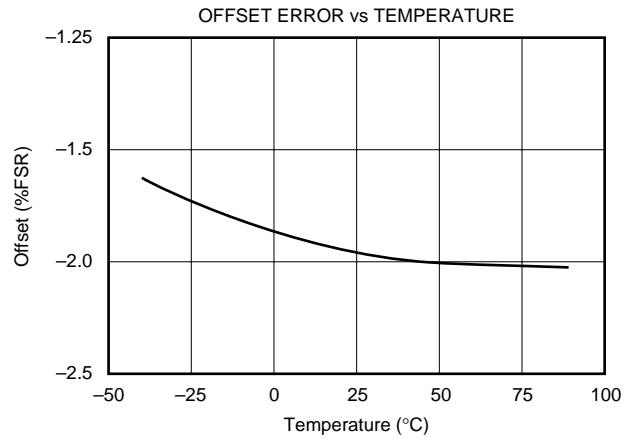
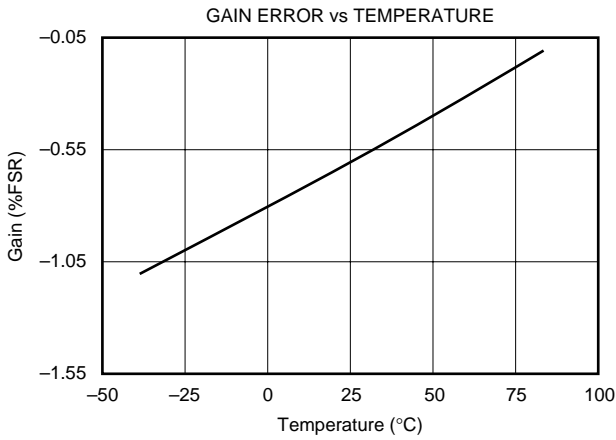

# THEORY OF OPERATION

The ADS802 is a high-speed, sampling A/D converter with pipelining. It uses a fully differential architecture and digital error correction to ensure 12-bit resolution. The differential track-and-hold circuit is shown in Figure 1. The switches are controlled by an internal clock that has a non-overlapping 2-phase signal,  $\phi_1$  and  $\phi_2$ . At the sampling time, the input signal is sampled on the bottom plates of the input capacitors. In the next clock phase,  $\phi_2$ , the bottom plates of the input capacitors are connected together and the feedback capacitors are switched to the op amp output. At this time, the charge redistributes between  $C_1$  and  $C_H$ , completing one track-and-hold cycle. The differential output is a held DC representation of the analog input at the sample time. The track-and-hold circuit can also convert a single-ended input signal into a fully differential signal for the quantizer.

The pipelined quantizer architecture has 11 stages with each stage containing a 2-bit quantizer and a 2-bit Digital-to-Analog Converter (DAC), as shown in Figure 2. Each 2-bit quantizer stage converts on the edge of the sub-clock, which is twice the frequency of the externally applied clock. The output of each quantizer is fed into its own delay line to time-

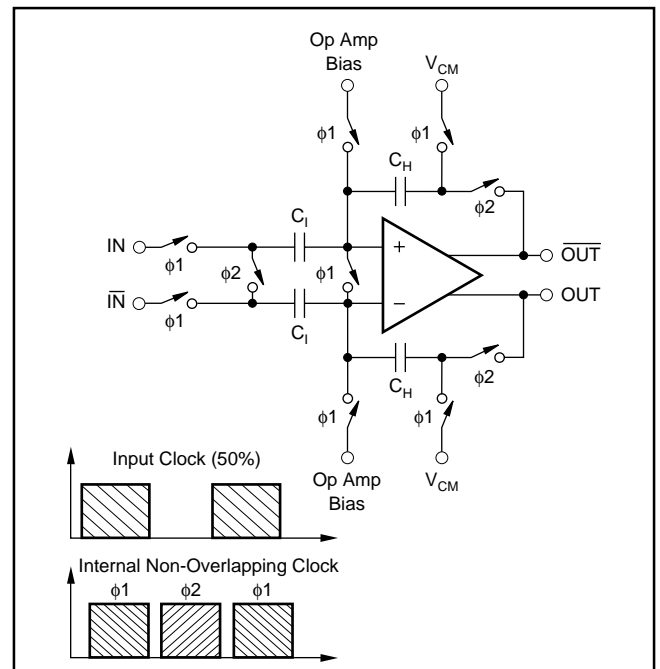

FIGURE 1. Input Track-and-Hold Configuration with Timing Signals.

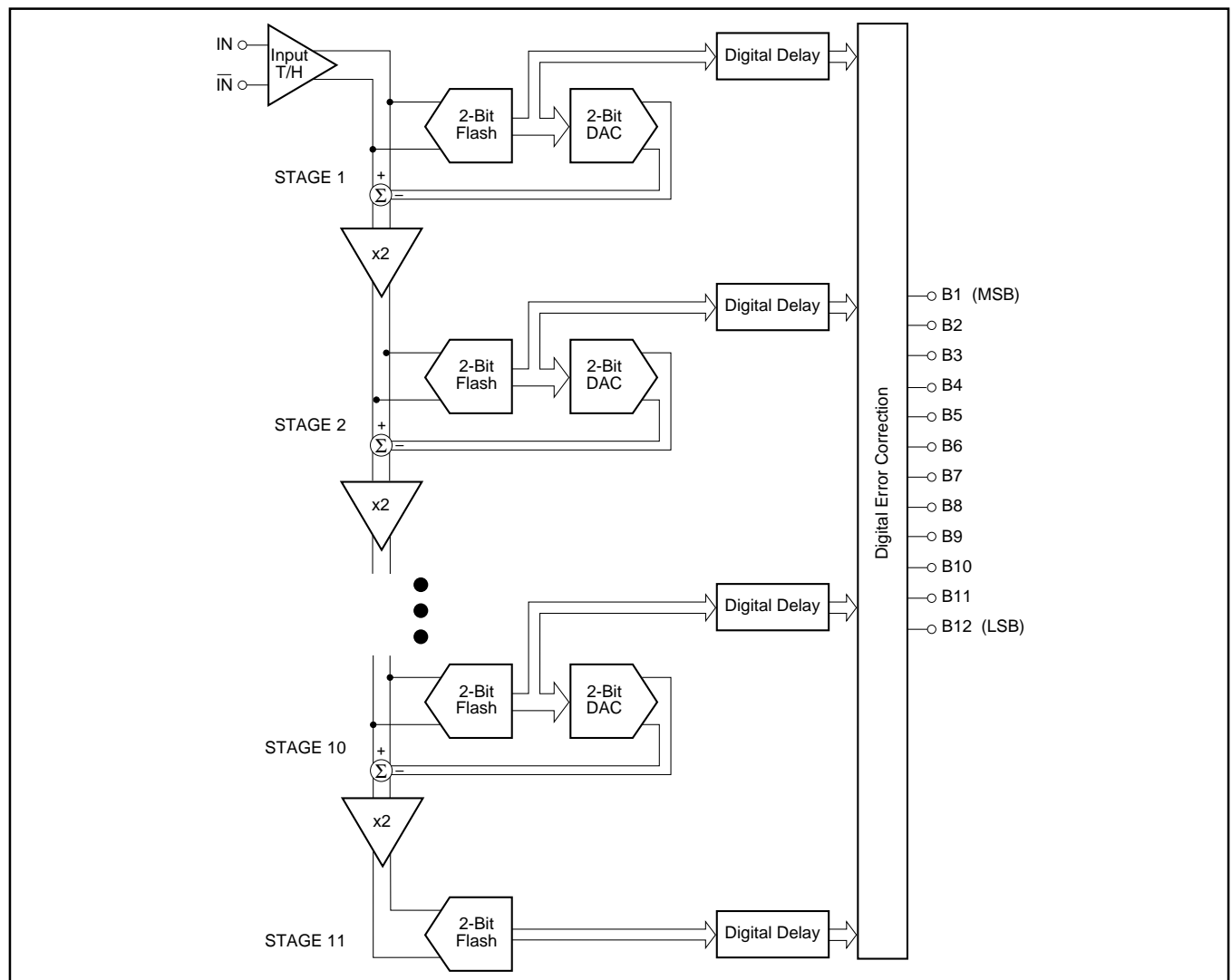

FIGURE 2. Pipeline A/D Converter Architecture.

align it with the data created from the following quantizer stages. This aligned data is fed into a digital error correction circuit that can adjust the output data based on the information found on the redundant bits. This technique gives the ADS802 excellent differential linearity and ensures no missing codes at the 12-bit level.

Since there are two pipeline stages per external clock cycle, there is a 6.5 clock cycle data latency from the start convert signal to the valid output data. The output data is available in Straight Offset Binary (SOB) or Binary Two's Complement (BTC) format.

## THE ANALOG INPUT AND INTERNAL REFERENCE

The analog input of the ADS802 can be configured in various ways and driven with different circuits, depending on the nature of the signal and the level of performance desired. The ADS802 has an internal reference that sets the full-scale input range of the A/D converter. The differential input range has each input centered around the common-mode of +2.25V, with each of the two inputs having a full-scale range of +1.25V to +3.25V. Since each input is 2Vp-p and 180° out-of-phase with the other, a 4V differential input signal to the quantizer results. As shown in Figure 3, the positive full-scale reference (REFT) and the negative full-scale (REFB) are brought out for external bypassing. In addition, the common-mode voltage (CM) may be used as a reference to provide the appropriate offset for the driving circuitry. However, care must be taken not to appreciably load this reference node. For more information regarding external references, single-ended input, and ADS802 drive circuits, refer to the applications section.

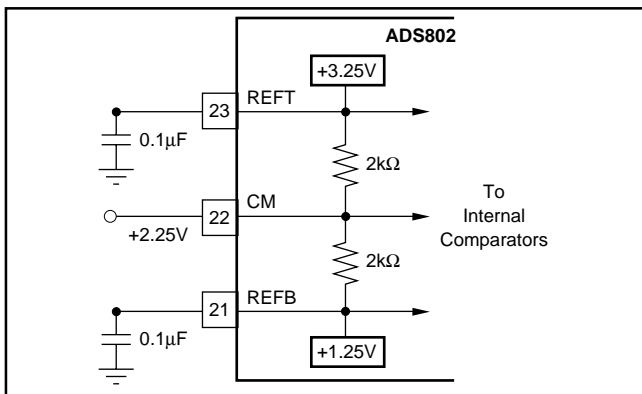

FIGURE 3. Internal Reference Structure.

## CLOCK REQUIREMENTS

The CLK pin accepts a CMOS level clock input. The rising and falling edges of the externally applied convert command clock controls the various interstage conversions in the pipeline. Therefore, the duty cycle of the clock should be held at 50% with low jitter and fast rise-and-fall times of 2ns or less. This is particularly important when digitizing a high-frequency input and operating at the maximum sample rate. Deviation from a 50% duty cycle will effectively shorten some of the interstage settling times, thus degrading the SNR and DNL performance.

## DIGITAL OUTPUT DATA

The 12-bit output data is provided at CMOS logic levels. The standard output coding is Straight Offset Binary (SOB) where a full-scale input signal corresponds to all “1s” at the output, as shown in Table I. This condition is met with pin 19 “LO” or Floating due to an internal pull-down resistor. By applying a logic “HI” voltage to this pin, a Binary Two's Complement (BTC) output will be provided where the most significant bit is inverted. The digital outputs of the ADS802 can be set to a high-impedance state by driving  $\overline{OE}$  (pin 18) with a logic “HI”. Normal operation is achieved with pin 18 “LO” or floating due to internal pull-down resistors. This function is provided for testability purposes and is not meant to drive digital buses directly, or be dynamically changed during the conversion process.

DIFFERENTIAL INPUT <sup>(1)</sup>	OUTPUT CODE	
	SOB PIN 19 FLOATING or LOW	BTC PIN 19 HIGH
+FS (IN = +3.25V, $\overline{IN}$ = +1.25V)	111111111111	011111111111
+FS - 1LSB	111111111111	011111111111
+FS - 2LSB	111111111110	011111111110
+3/4 Full-Scale	111000000000	011000000000
+1/2 Full-Scale	110000000000	010000000000
+1/4 Full-Scale	101000000000	001000000000
+1LSB	100000000001	000000000001
Bipolar Zero (IN = $\overline{IN}$ = +2.25V)	100000000000	000000000000
-1LSB	011111111111	111111111111
-1/4 Full-Scale	011000000000	111000000000
-1/2 Full-Scale	010000000000	110000000000
-3/4 Full-Scale	001000000000	101000000000
-FS + 1LSB	000000000001	100000000001
-FS (IN = +1.25V, $\overline{IN}$ = +3.25V)	000000000000	100000000000

NOTE: (1) In the single-ended input mode, +FS = +4.25V and -FS = +0.25V.

TABLE I. Coding Table for the ADS802.

## APPLICATIONS

### DRIVING THE ADS802

The ADS802 has a differential input with a common-mode of +2.25V. For AC-coupled applications, the simplest way to create this differential input is to drive the primary winding of a transformer with a single-ended input. A differential output is created on the secondary if the center tap is tied to the common-mode voltage of +2.25V, as in Figure 4. This trans-

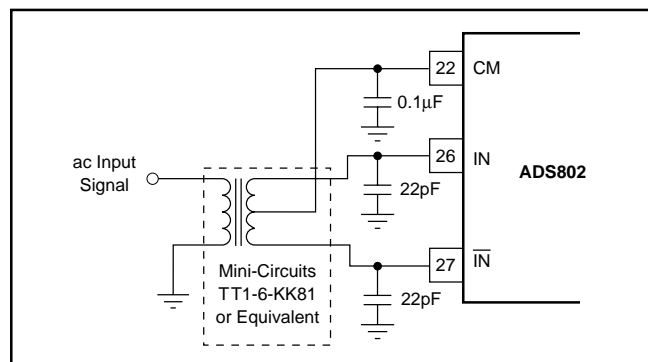

FIGURE 4. AC-Coupled Single-Ended to Differential Drive Circuit Using a Transformer.

former-coupled input arrangement provides good high-frequency AC performance. It is important to select a transformer that gives low distortion and does not exhibit core saturation at full-scale voltage levels. Since the transformer does not appreciably load the ladder, there is no need to buffer the Common-Mode (CM) output in this instance. In general, it is advisable to keep the current draw from the CM output pin below  $0.5\mu\text{A}$  to avoid nonlinearity in the internal reference ladder. A FET input operational amplifier, such as the OPA130, can provide a buffered reference for driving external circuitry. The analog IN and  $\overline{\text{IN}}$  inputs should be bypassed with 22pF capacitors to minimize track-and-hold glitches and to improve high input frequency performance.

Figure 5 illustrates another possible low-cost interface circuit that utilizes resistors and capacitors in place of a transformer. Depending on the signal bandwidth, the component values should be carefully selected in order to maintain the product performance. The input capacitors,  $C_{\text{IN}}$ , and the input resistors,  $R_{\text{IN}}$ , create a high-pass filter with the lower corner frequency at  $f_c = 1/(2\pi R_{\text{IN}} C_{\text{IN}})$ . The corner frequency can be reduced by either increasing the value of  $R_{\text{IN}}$  or  $C_{\text{IN}}$ . If the circuit operates with a  $50\Omega$  or  $75\Omega$  impedance level, the resistors are fixed and only the value of the capacitor can be increased. Usually AC-coupling capacitors are electrolytic or tantalum capacitors with values of  $1\mu\text{F}$  or higher. It should be noted that these large capacitors become inductive with increased input frequency, which could lead to signal amplitude errors or oscillation. To maintain a low AC-coupling impedance throughout the signal band, a small value (e.g.  $1\mu\text{F}$ ) ceramic capacitor could be added in parallel with the polarized capacitor.

Capacitors  $C_{\text{SH}1}$  and  $C_{\text{SH}2}$  are used to minimize current glitches resulting from the switching in the input track-and-hold stage and to improve signal-to-noise performance. These capacitors can also be used to establish a low-pass filter and effectively reduce the noise bandwidth. In order to create a real pole, resistors  $R_{\text{SER}1}$  and  $R_{\text{SER}2}$  were added in series with each input. The cutoff frequency of the filter is deter-

mined by  $f_c = 1/(2\pi R_{\text{SER}} \cdot (C_{\text{SH}} + C_{\text{ADC}}))$ , where  $R_{\text{SER}}$  is the resistor in series with the input,  $C_{\text{SH}}$  is the external capacitor from the input to ground, and  $C_{\text{ADC}}$  is the internal input capacitance of the A/D converter (typically 4pF).

Resistors  $R_1$  and  $R_2$  are used to derive the necessary common-mode voltage from the buffered top and bottom references. The total load of the resistor string should be selected so that the current does not exceed 1mA. Although the circuit in Figure 5 uses two resistors of equal value so that the common-mode voltage is centered between the top and bottom reference ( $+2.25\text{V}$ ), it is not necessary to do so. In all cases the center point,  $V_{\text{CM}}$ , should be bypassed to ground in order to provide a low-impedance AC ground.

If the signal needs to be DC-coupled to the input of the ADS802, an operational amplifier input circuit is required. In the differential input mode, any single-ended signal must be modified to create a differential signal. This can be accomplished by using two operational amplifiers; one in the noninverting mode for the input and the other amplifier in the inverting mode for the complementary input. The low distortion circuit in Figure 6 will provide the necessary input shifting required for signals centered around ground. It also employs a diode for output level shifting to ensure a low distortion  $+3.25\text{V}$  output swing. Other amplifiers can be used in place of the OPA842s if the lowest distortion is not necessary. If output level shifting circuits are not used, care must be taken to select operational amplifiers that give the necessary performance when swinging to  $+3.25\text{V}$  with a  $\pm 5\text{V}$  supply operational amplifier.

The ADS802 can also be configured with a single-ended input full-scale range of  $+0.25\text{V}$  to  $+4.25\text{V}$  by tying the complementary input to the common-mode reference voltage (see Figure 7). This configuration will result in increased even-order harmonics, especially at higher input frequencies. However, this tradeoff may be quite acceptable for time-domain applications. The driving amplifier must give adequate performance with a  $+0.25\text{V}$  to  $+4.25\text{V}$  output swing in this case.

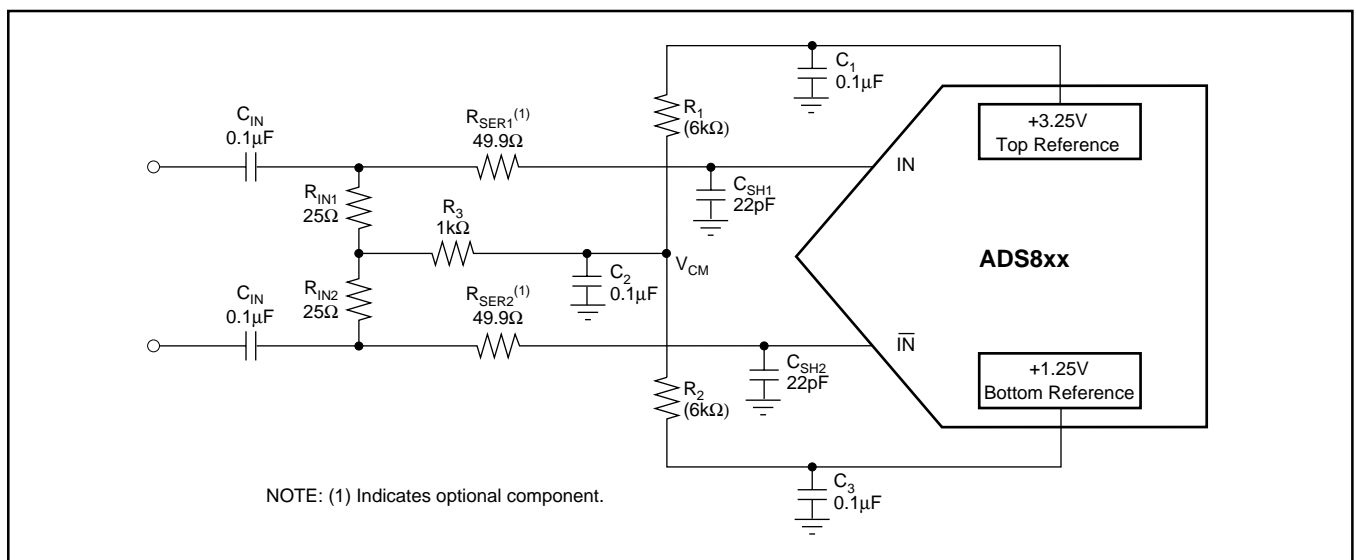

FIGURE 5. AC-Coupled Differential Input Circuit.

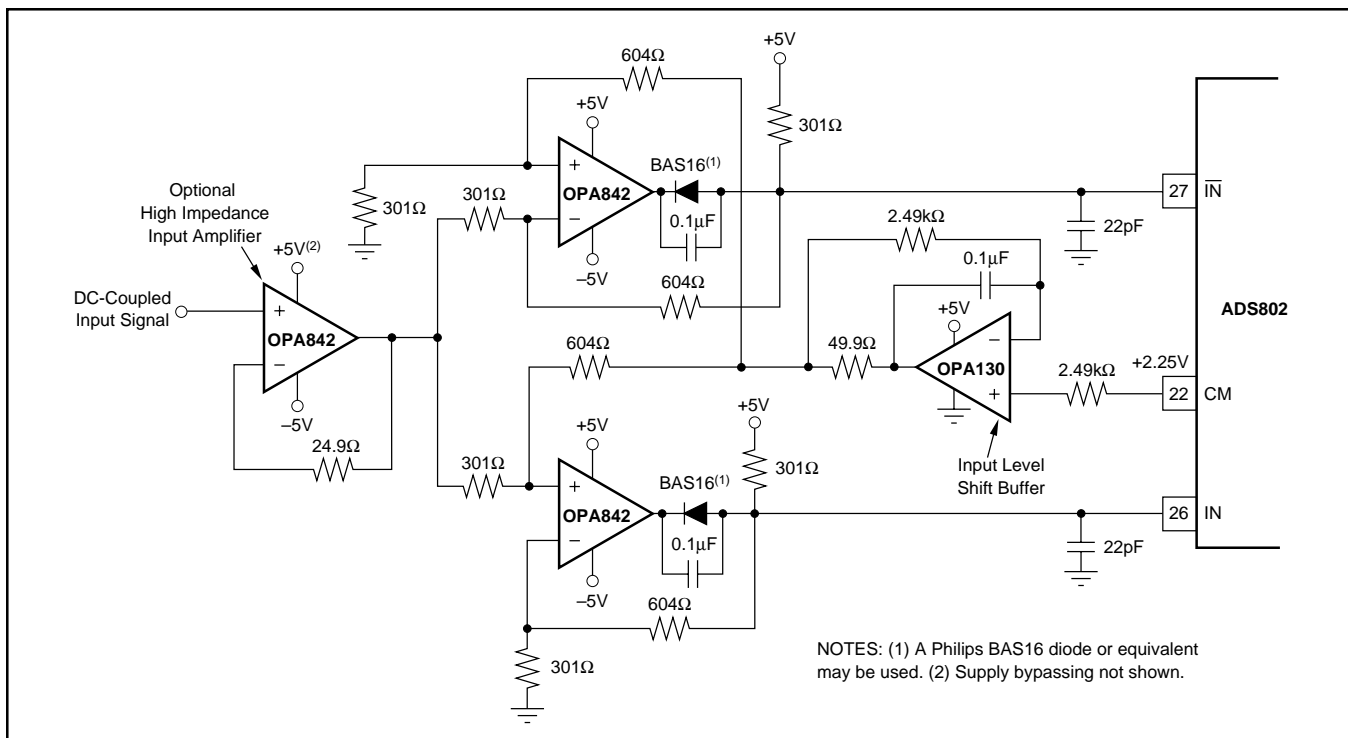

FIGURE 6. A Low-Distortion, DC-Coupled, Single-Ended to Differential Input Driver Circuit.

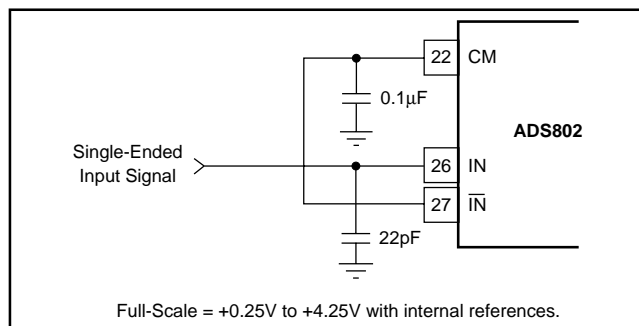

FIGURE 7. Single-Ended Input Connection.

## EXTERNAL REFERENCES AND ADJUSTMENT OF FULL-SCALE RANGE

The internal reference buffers are limited to approximately 1mA of output current. As a result, these internal +1.25V and +3.25V references may be overridden by external references that have at least 18mA (at room temperature) of output drive capability. In this instance, the common-mode voltage will be set halfway between the two references. This feature can be used to adjust the gain error, improve gain drift, or to change the full-scale input range of the ADS802. Changing the full-scale range to a lower value has the benefit of easing the swing requirements of external input amplifiers. The external references can vary as long as the value of the external top reference ( $REF_{T\_EXT}$ ) is less than or equal to +3.4V, the value of the external bottom reference ( $REF_{B\_EXT}$ ) is greater than or equal to +1.1V, and the difference between the external references are greater than or equal to 1.5V.

For the differential configuration, the full-scale input range will be set to the external reference values that are selected. For the single-ended mode, the input range is  $2 \cdot (REF_{T\_EXT} - REF_{B\_EXT})$ , with the common-mode being centered at  $(REF_{T\_EXT} + REF_{B\_EXT})/2$ . Refer to the typical characteristics for expected performance versus full-scale input range.

The circuit in Figure 8 works completely on a single +5V supply. As a reference element, it uses micro-power reference REF1004-2.5 that is set to a quiescent current of 0.1mA. Amplifier  $A_2$  is configured as a follower to buffer the +1.25V generated from the resistor divider. To provide the necessary current drive, a pull-down resistor ( $R_P$ ) is added. Amplifier  $A_1$  is configured as an adjustable-gain stage, with a range of approximately 1 to 1.32. The pull-up resistor again relieves the op amp from providing the full current drive. The value of the pull-up, pull-down resistors is not critical and can be varied to optimize power consumption. The need for pull-up, pull-down resistors depends only on the drive capability of the selected drive amplifiers, and thus can be omitted.

## PC-BOARD LAYOUT AND BYPASSING

A well-designed, clean pc-board layout will assure proper operation and clean spectral response. Proper grounding and bypassing, short lead lengths, and the use of ground planes are particularly important for high-frequency circuits. Multilayer pc-boards are recommended for best performance, but if carefully designed, a two-sided pc-board with large, heavy

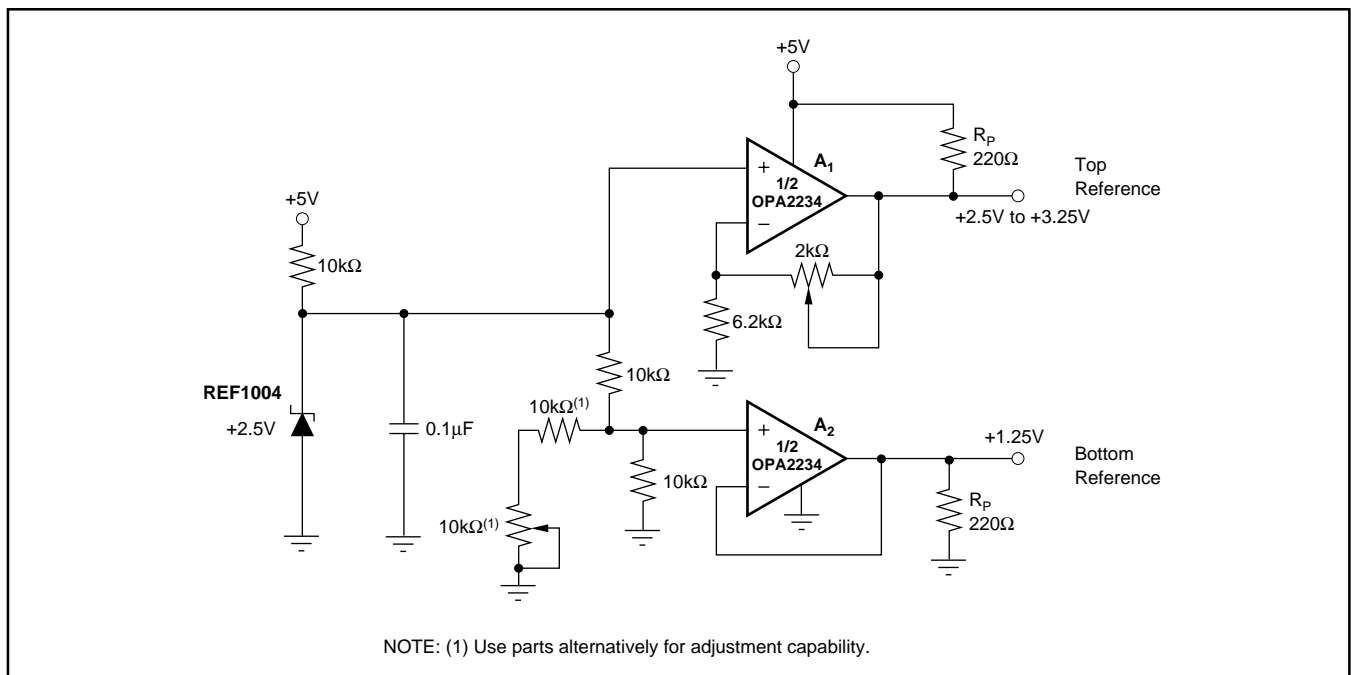

FIGURE 8. Optional External Reference to Set the Full-Scale Range Utilizing a Dual, Single-Supply Op Amp.

ground planes can give excellent results. It is recommended that the analog and digital ground pins of the ADS802 be connected directly to the analog ground plane. In our experience, this gives the most consistent results. The A/D converter power-supply commons should be tied together at the analog ground plane. Power supplies should be bypassed with 0.1μF ceramic capacitors as close to the pin as possible.

### DYNAMIC PERFORMANCE TESTING

The ADS802 is a high-performance converter and careful attention to test techniques is necessary to achieve accurate results. Highly accurate phase-locked signal sources allow high resolution FFT measurements to be made without using data windowing functions. A low-jitter signal generator, such as the HP8644A for the test signal, phase-locked with a low-jitter HP8022A pulse generator for the A/D converter clock, gives excellent results. Low-pass filtering (or bandpass filtering) of test signals is absolutely necessary to test the low distortion of the ADS802. Using a signal amplitude slightly lower than full-scale will allow a small amount of “headroom” so that noise or DC-offset voltage will not overrange the A/D converter and cause clipping on signal peaks.

### DYNAMIC PERFORMANCE DEFINITIONS

1. Signal-to-Noise-and-Distortion Ratio (SINAD):
 
$$10 \log \frac{\text{Sinewave Signal Power}}{\text{Noise} + \text{Harmonic Power (first 15 harmonics)}}$$
2. Signal-to-Noise Ratio (SNR):
 
$$10 \log \frac{\text{Sinewave Signal Power}}{\text{Noise Power}}$$
3. Intermodulation Distortion (IMD):
 
$$10 \log \frac{\text{Highest IMD Product Power (to 5th - order)}}{\text{Sinewave Signal Power}}$$

IMD is referenced to the larger of the test signals  $f_1$  or  $f_2$ . Five “bins” either side of peak are used for calculation of fundamental and harmonic power. The “0” frequency bin (DC) is not included in these calculations, as it is of little importance in dynamic signal processing applications.

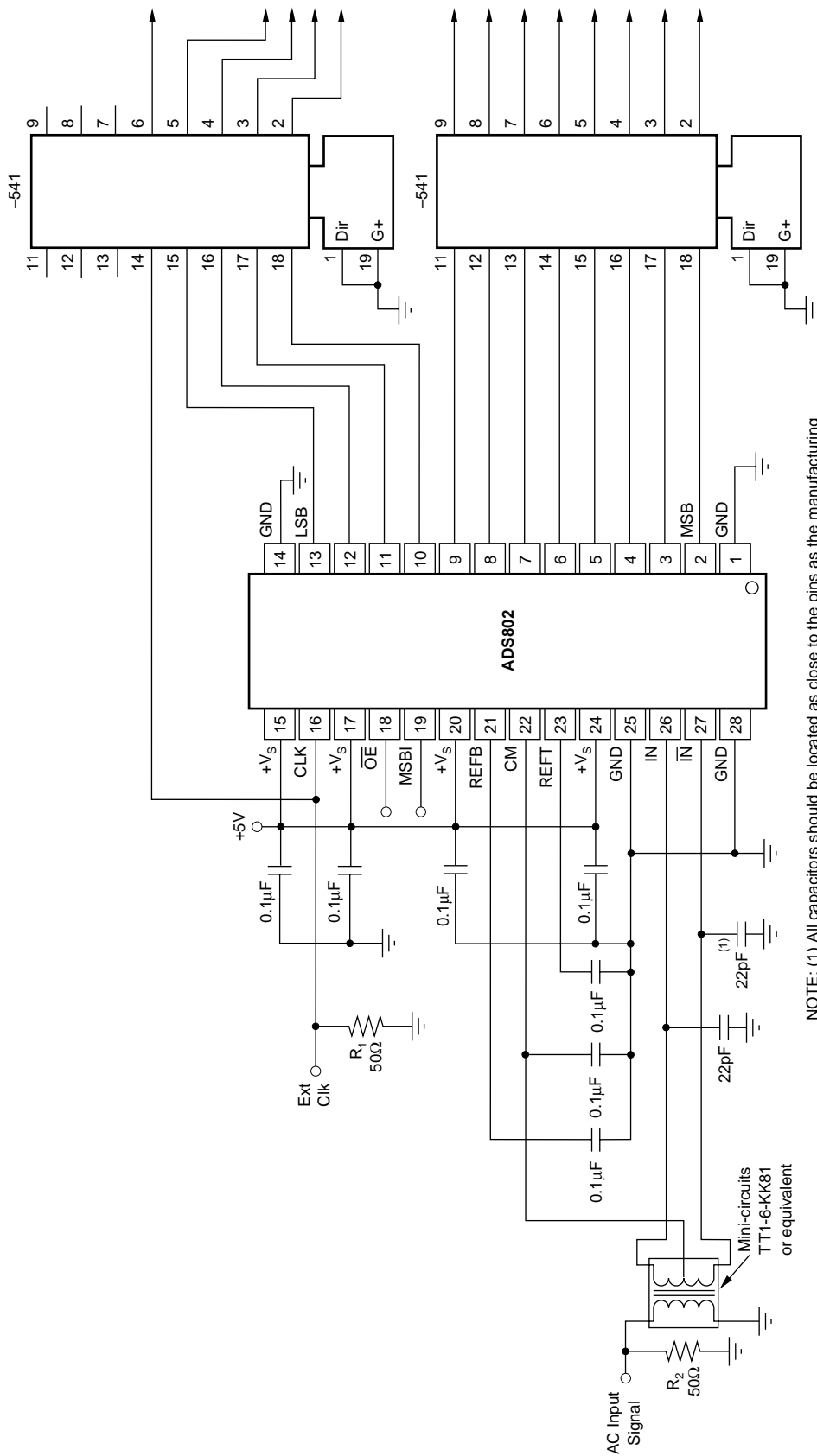

NOTE: (1) All capacitors should be located as close to the pins as the manufacturing process will allow. Ceramic X7R surface-mount capacitors or equivalent are recommended.

FIGURE 9. ADS802 Interface Schematic with AC-Coupling and External Buffers.

**PACKAGING INFORMATION**

Orderable Device	Status (1)	Package Type	Package Drawing	Pins	Package Qty	Eco Plan (2)	Lead finish/ Ball material (6)	MSL Peak Temp (3)	Op Temp (°C)	Device Marking (4/5)	Samples
ADS802U	ACTIVE	SOIC	DW	28	20	RoHS & Green	NIPDAU	Level-2-260C-1 YEAR	-40 to 85	ADS802U	Samples

(1) The marketing status values are defined as follows:

**ACTIVE:** Product device recommended for new designs.

**LIFEBUY:** TI has announced that the device will be discontinued, and a lifetime-buy period is in effect.

**NRND:** Not recommended for new designs. Device is in production to support existing customers, but TI does not recommend using this part in a new design.

**PREVIEW:** Device has been announced but is not in production. Samples may or may not be available.

**OBSOLETE:** TI has discontinued the production of the device.

(2) **RoHS:** TI defines "RoHS" to mean semiconductor products that are compliant with the current EU RoHS requirements for all 10 RoHS substances, including the requirement that RoHS substance do not exceed 0.1% by weight in homogeneous materials. Where designed to be soldered at high temperatures, "RoHS" products are suitable for use in specified lead-free processes. TI may reference these types of products as "Pb-Free".

**RoHS Exempt:** TI defines "RoHS Exempt" to mean products that contain lead but are compliant with EU RoHS pursuant to a specific EU RoHS exemption.

**Green:** TI defines "Green" to mean the content of Chlorine (Cl) and Bromine (Br) based flame retardants meet JS709B low halogen requirements of <=1000ppm threshold. Antimony trioxide based flame retardants must also meet the <=1000ppm threshold requirement.

(3) MSL, Peak Temp. - The Moisture Sensitivity Level rating according to the JEDEC industry standard classifications, and peak solder temperature.

(4) There may be additional marking, which relates to the logo, the lot trace code information, or the environmental category on the device.

(5) Multiple Device Markings will be inside parentheses. Only one Device Marking contained in parentheses and separated by a "-" will appear on a device. If a line is indented then it is a continuation of the previous line and the two combined represent the entire Device Marking for that device.

(6) Lead finish/Ball material - Orderable Devices may have multiple material finish options. Finish options are separated by a vertical ruled line. Lead finish/Ball material values may wrap to two lines if the finish value exceeds the maximum column width.

**Important Information and Disclaimer:**The information provided on this page represents TI's knowledge and belief as of the date that it is provided. TI bases its knowledge and belief on information provided by third parties, and makes no representation or warranty as to the accuracy of such information. Efforts are underway to better integrate information from third parties. TI has taken and continues to take reasonable steps to provide representative and accurate information but may not have conducted destructive testing or chemical analysis on incoming materials and chemicals. TI and TI suppliers consider certain information to be proprietary, and thus CAS numbers and other limited information may not be available for release.

In no event shall TI's liability arising out of such information exceed the total purchase price of the TI part(s) at issue in this document sold by TI to Customer on an annual basis.

**TUBE**

\*All dimensions are nominal

Device	Package Name	Package Type	Pins	SPQ	L (mm)	W (mm)	T (μm)	B (mm)
ADS802U	DW	SOIC	28	20	506.98	12.7	4826	6.6

DW (R-PDSO-G28)

PLASTIC SMALL OUTLINE

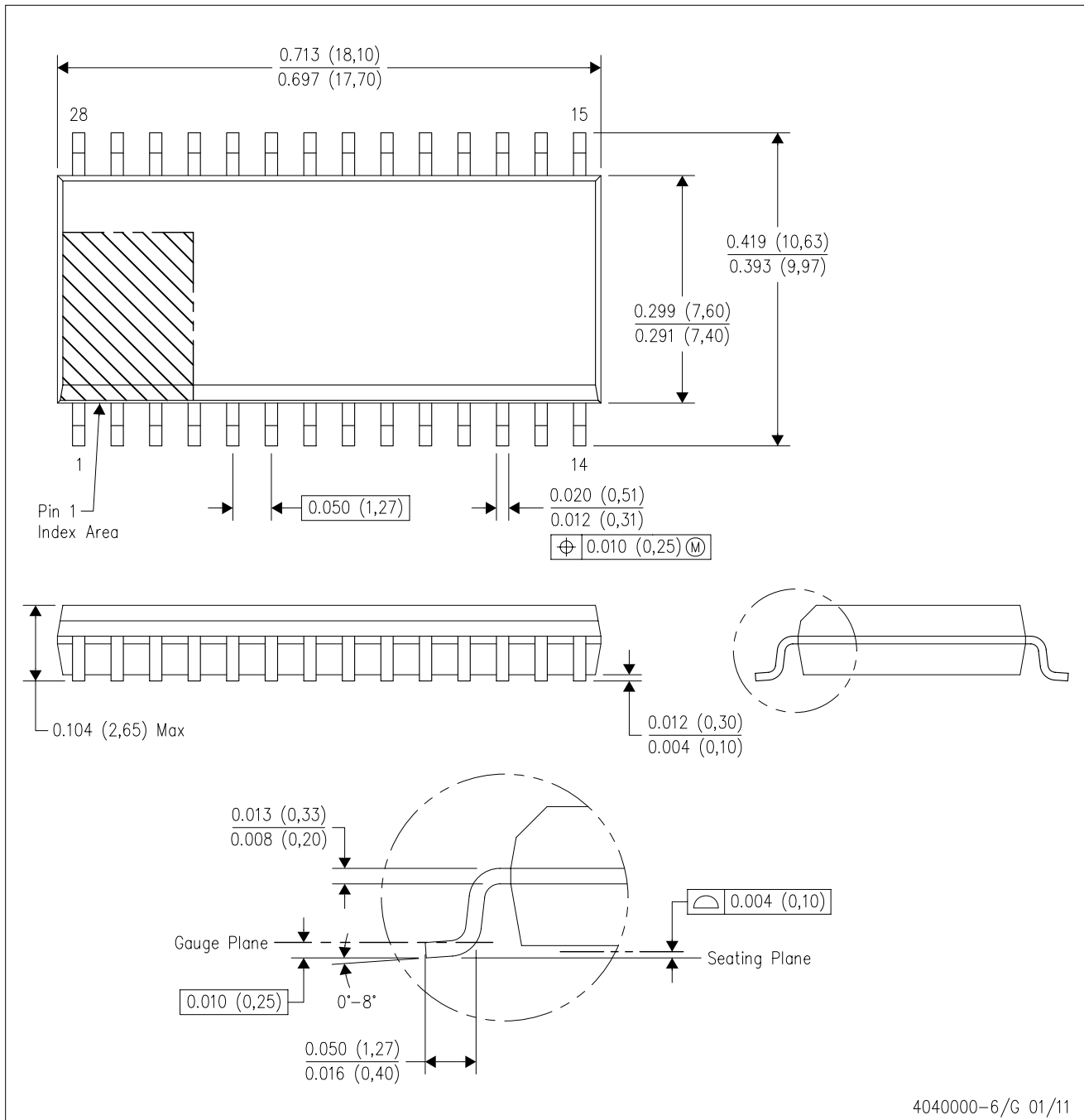

- NOTES:
- All linear dimensions are in inches (millimeters). Dimensioning and tolerancing per ASME Y14.5M-1994.
  - This drawing is subject to change without notice.
  - Body dimensions do not include mold flash or protrusion not to exceed 0.006 (0,15).
  - Falls within JEDEC MS-013 variation AE.

DW (R-PDSO-G28)

PLASTIC SMALL OUTLINE

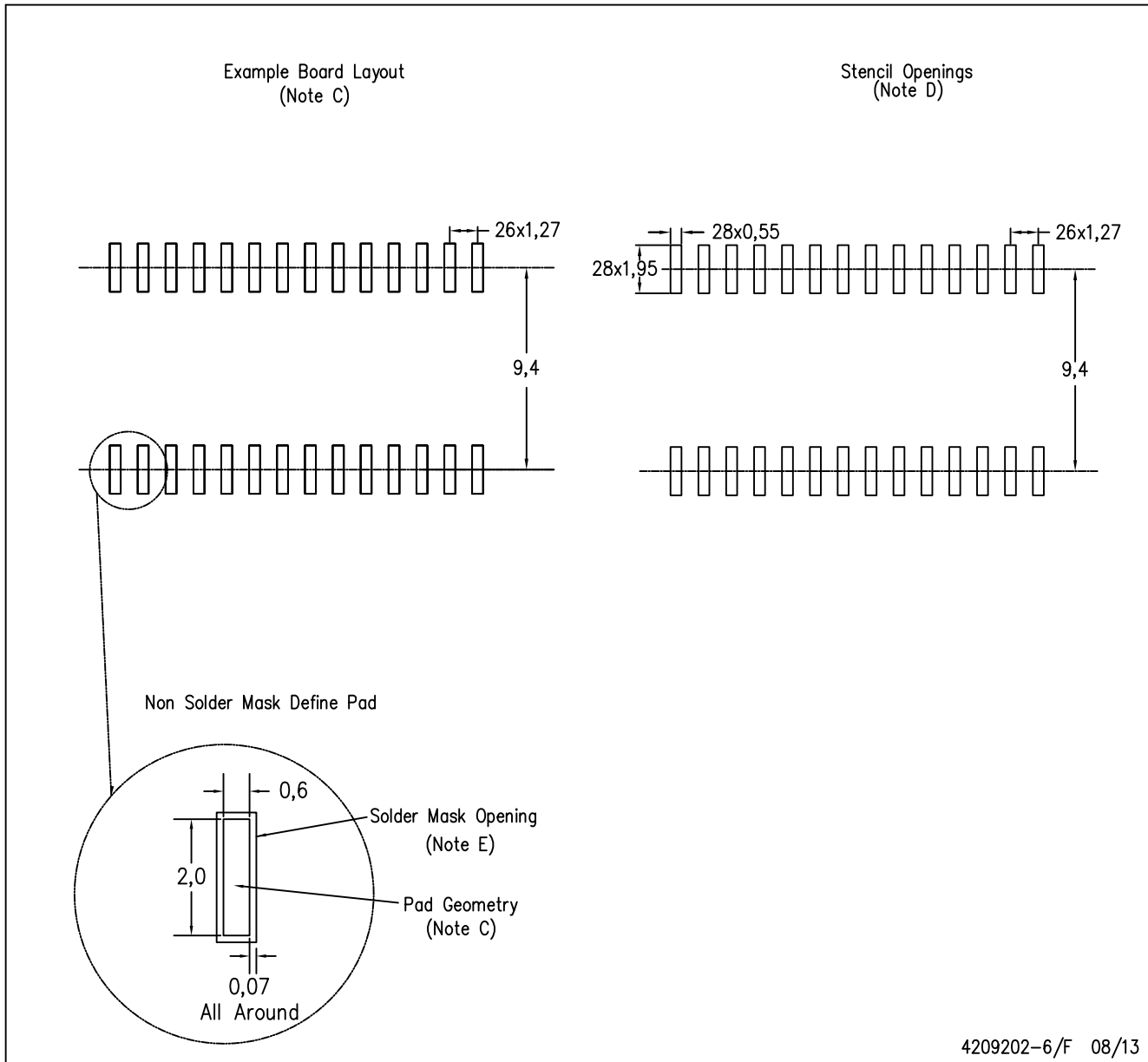

4209202-6/F 08/13

- NOTES:
- A. All linear dimensions are in millimeters.
  - B. This drawing is subject to change without notice.
  - C. Refer to IPC7351 for alternate board design.
  - D. Laser cutting apertures with trapezoidal walls and also rounding corners will offer better paste release. Customers should contact their board assembly site for stencil design recommendations. Refer to IPC-7525
  - E. Customers should contact their board fabrication site for solder mask tolerances between and around signal pads.

## IMPORTANT NOTICE AND DISCLAIMER

TI PROVIDES TECHNICAL AND RELIABILITY DATA (INCLUDING DATA SHEETS), DESIGN RESOURCES (INCLUDING REFERENCE DESIGNS), APPLICATION OR OTHER DESIGN ADVICE, WEB TOOLS, SAFETY INFORMATION, AND OTHER RESOURCES "AS IS" AND WITH ALL FAULTS, AND DISCLAIMS ALL WARRANTIES, EXPRESS AND IMPLIED, INCLUDING WITHOUT LIMITATION ANY IMPLIED WARRANTIES OF MERCHANTABILITY, FITNESS FOR A PARTICULAR PURPOSE OR NON-INFRINGEMENT OF THIRD PARTY INTELLECTUAL PROPERTY RIGHTS.

These resources are intended for skilled developers designing with TI products. You are solely responsible for (1) selecting the appropriate TI products for your application, (2) designing, validating and testing your application, and (3) ensuring your application meets applicable standards, and any other safety, security, regulatory or other requirements.

These resources are subject to change without notice. TI grants you permission to use these resources only for development of an application that uses the TI products described in the resource. Other reproduction and display of these resources is prohibited. No license is granted to any other TI intellectual property right or to any third party intellectual property right. TI disclaims responsibility for, and you will fully indemnify TI and its representatives against, any claims, damages, costs, losses, and liabilities arising out of your use of these resources.

TI's products are provided subject to [TI's Terms of Sale](#) or other applicable terms available either on [ti.com](http://ti.com) or provided in conjunction with such TI products. TI's provision of these resources does not expand or otherwise alter TI's applicable warranties or warranty disclaimers for TI products.

TI objects to and rejects any additional or different terms you may have proposed.

Mailing Address: Texas Instruments, Post Office Box 655303, Dallas, Texas 75265  
Copyright © 2022, Texas Instruments Incorporated

## Looking for pricing, stock, or lifecycle information?

Click below to explore more details on WIN SOURCE:

 [View ADS802U on WIN SOURCE](#)

 [Texas Instruments](#) Information

## Optimize Your Supply Chain with WIN SOURCE Solutions

-  Global Sourcing Solution
-  Obsolete Management
-  Cost Control Management
-  Shortage Management
-  Alternative Solution
-  Excess Inventory Management