



**THE DATASHEET OF
PSD834F2-90JI**





PSD8XXFX

Flash in-system programmable (ISP) peripherals for 8-bit MCUs, 5 V

Features

- Flash in-system programmable (ISP) peripheral for 8-bit MCUs
- Dual bank Flash memories
 - Up to 2 Mbit of primary Flash memory (8 uniform sectors, 32K x8)
 - Up to 256 Kbit secondary Flash memory (4 uniform sectors)
 - Concurrent operation: read from one memory while erasing and writing the other
- Up to 256 Kbit SRAM
- 27 reconfigurable I/O ports
- Enhanced JTAG serial port
- PLD with macrocells
 - Over 3000 gates of PLD: CPLD and DPLD
 - CPLD with 16 output macrocells (OMCs) and 24 input macrocells (IMCs)
 - DPLD - user defined internal chip select decoding
- 27 individually configurable I/O port pins
They can be used for the following functions:
 - MCU I/Os
 - PLD I/Os
 - Latched MCU address output
 - Special function I/Os.16 of the I/O ports may be configured as open-drain outputs.
- In-system programming (ISP) with JTAG
 - Built-in JTAG compliant serial port allows full-chip in-system programmability
 - Efficient manufacturing allow easy product testing and programming
 - Use low cost FlashLINK cable with PC
- Page register
 - Internal page register that can be used to expand the microcontroller address space by a factor of 256

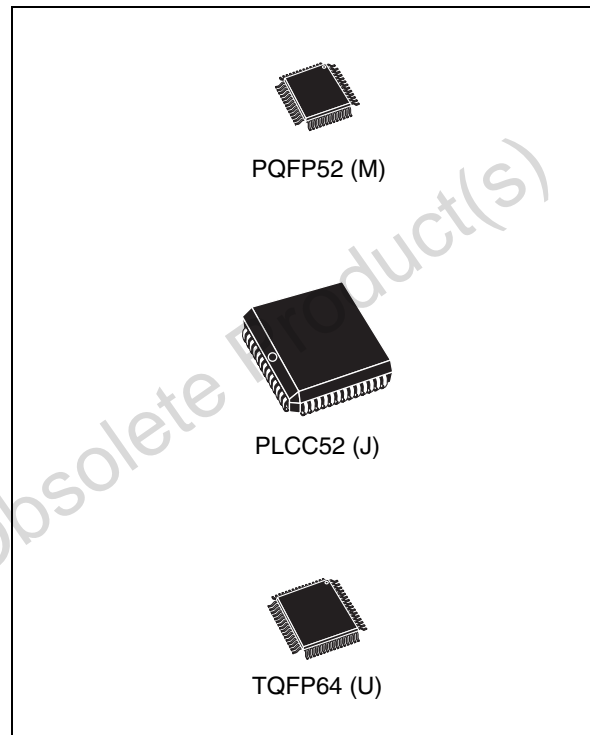

- Programmable power management
- Packages are ECOPACK®

Table 1. Device summary

Reference	Part number
PSD8XXFX	PSD813F2
	PSD813F4
	PSD813F5
	PSD833F2
	PSD834F2
	PSD853F2
	PSD854F2

Contents

1	Summary description	11
2	Pin description	15
3	PSD architectural overview	20
3.1	Memory	20
3.2	Page register	20
3.3	PLDs	20
3.4	I/O ports	21
3.5	MCU bus interface	21
3.6	JTAG port	21
3.7	In-system programming (ISP)	21
3.8	Power management unit (PMU)	21
4	Development system	23
5	PSD register description and address offset	24
6	Detailed operation	26
6.1	Memory blocks	26
6.2	Description of primary Flash memory and secondary Flash memory	27
6.3	Memory block select signals	27
6.3.1	Ready/Busy (PC3)	27
6.3.2	Memory operation	27
7	Instructions	30
7.1	Power-up mode	30
7.2	READ	30
7.3	Read memory contents	31
7.4	Read Primary Flash Identifier	31
7.5	Read Memory Sector Protection status	31
7.6	Reading the Erase/Program Status bits	31
7.7	Data Polling flag (DQ7)	32

7.8	Toggle flag (DQ6)	32
7.9	Error flag (DQ5)	33
7.10	Erase timeout flag (DQ3)	33
8	Programming Flash memory	34
8.1	Data Polling	34
8.2	Data Toggle	35
8.3	Unlock Bypass (PSD833F2x, PSD834F2x, PSD853F2x, PSD854F2x) ..	36
9	Erasing Flash memory	38
9.1	Flash Bulk Erase	38
9.2	Flash Sector Erase	38
9.3	Suspend Sector Erase	38
9.4	Resume Sector Erase	39
10	Specific features	40
10.1	Flash Memory Sector Protect	40
10.2	Reset Flash	40
10.3	Reset (RESET) signal (on the PSD83xF2 and PSD85xF2)	41
11	SRAM	42
12	Sector Select and SRAM Select	43
12.1	Example	43
12.2	Memory select configuration for MCUs with separate program and data spaces	43
12.3	Configuration modes for MCUs with separate program and data spaces	44
12.3.1	Separate Space modes	44
12.3.2	Combined Space modes	44
13	Page register	46
14	PLDS	47
14.1	The Turbo Bit in PSD	47
14.2	Decode PLD (DPLD)	50
14.3	Complex PLD (CPLD)	51

14.4	Output macrocell (OMC)	53
14.5	Product Term Allocator	54
14.6	Loading and reading the Output macrocells (OMC)	54
14.7	The OMC Mask register	54
14.8	The Output Enable of the OMC	54
14.9	Input macrocells (IMC)	56
15	MCU bus interface	59
15.1	PSD interface to a multiplexed 8-bit bus	60
15.2	PSD interface to a non-multiplexed 8-bit bus	60
15.3	Data Byte Enable reference	60
15.4	MCU bus interface examples	61
15.5	80C31	62
15.6	80C251	63
15.7	80C51XA	65
15.8	68HC11	66
16	I/O ports	67
16.1	General port architecture	67
16.2	Port operating modes	68
16.3	MCU I/O mode	69
16.4	PLD I/O mode	69
16.5	Address Out mode	69
16.6	Address In mode	71
16.7	Data port mode	71
16.8	Peripheral I/O mode	71
16.9	JTAG in-system programming (ISP)	71
16.10	Port configuration registers (PCR)	72
16.11	Control register	72
16.12	Direction register	72
16.13	Drive Select register	72
16.14	Port Data registers	74
16.15	Data In	74
16.16	Data Out register	74

16.17	OMC Mask register	74
16.18	Input macro (IMC)	74
16.19	Enable Out	75
16.20	Ports A and B – functionality and structure	75
16.21	Port C – functionality and structure	76
16.22	Port D – functionality and structure	76
16.23	External Chip Select	77
17	Power management	79
17.1	Automatic Power-down (APD) Unit and Power-down mode	80
17.2	For users of the HC11 (or compatible)	81
17.3	Other power saving options	81
17.4	PLD power management	82
17.5	PSD Chip Select input (CSI, PD2)	84
17.6	Input clock	84
17.7	Input control signals	84
18	Reset timing and device status at reset	85
18.1	Power-up reset	85
18.2	Warm reset	85
18.3	I/O pin, register and PLD status at Reset	85
18.4	Reset of Flash memory erase and program cycles (on the PSD834Fx)	85
19	Programming in-circuit using the JTAG serial interface	87
19.1	Standard JTAG signals	87
19.2	JTAG extensions	88
19.3	Security and Flash memory protection	88
20	Initial delivery state	90
21	Maximum rating	91
22	AC/DC parameters	92
23	Package mechanical	116

24	Part numbering	120
Appendix A	PQFP52 pin assignments	121
Appendix B	PLCC52 pin assignments	123
Appendix C	TQFP64 pin assignments	125
Revision history	127

Obsolete Product(s) - Obsolete Product(s)

List of tables

Table 1.	Device summary	1
Table 2.	Product range	11
Table 3.	PLCC52 pin description	15
Table 4.	PLD I/O	21
Table 5.	JTAG Signals on port C	22
Table 6.	Methods for programming different functional blocks of the PSD.	22
Table 7.	I/O port latched address output assignments	24
Table 8.	Register address offset	24
Table 9.	Memory block size and organization	26
Table 10.	Instructions	28
Table 11.	Status bits	32
Table 12.	Sector Protection/Security Bit definition – Flash Protection register.	41
Table 13.	Sector Protection/Security Bit definition – PSD/EE Protection register	41
Table 14.	VM register	45
Table 15.	DPLD and CPLD inputs	47
Table 16.	Output macrocell port and data bit assignments	53
Table 17.	MCUs and their control signals	59
Table 18.	8-bit data bus	61
Table 19.	80C251 configurations	64
Table 20.	Port operating modes	69
Table 21.	Port operating mode settings	70
Table 22.	I/O port Latched address output assignments	70
Table 23.	Port configuration registers (PCR)t.	73
Table 24.	Port Pin Direction Control, Output Enable P.T. not defined	73
Table 25.	Port Pin Direction Control, Output Enable P.T. defined	73
Table 26.	Port Direction assignment example	73
Table 27.	Drive register pin assignment	73
Table 28.	Port Data registers	74
Table 29.	Power-down mode's effect on ports	80
Table 30.	PSD timing and standby current during Power-down mode	81
Table 31.	Power Management mode registers PMMR0.	82
Table 32.	Power Management mode registers PMMR2.	83
Table 33.	APD counter operation	84
Table 34.	Status during Power-on reset, Warm reset and Power-down mode.	86
Table 35.	JTAG port signals	89
Table 36.	JTAG Enable register	90
Table 37.	Absolute maximum ratings	91
Table 38.	Example of PSD typical power calculation at $V_{CC}=5.0$ V (Turbo mode on)	93
Table 39.	Example of PSD typical power calculation at $V_{CC} = 5.0$ V (Turbo mode off)	94
Table 40.	Operating conditions (5 V devices)	95
Table 41.	Operating conditions (3 V devices)	95
Table 42.	AC signal letters for PLD timing	96
Table 43.	AC signal behavior symbols for PLD timing	96
Table 44.	AC measurement conditions.	96
Table 45.	Capacitance	97
Table 46.	DC characteristics (5 V devices)	98
Table 47.	DC Characteristics (3 V devices)	99
Table 48.	CPLD combinatorial timing (5 V devices)	100

Table 49.	CPLD combinatorial timing (3 V devices)	100
Table 50.	CPLD macrocell Synchronous clock mode timing (5 V devices)	101
Table 51.	CPLD macrocell synchronous clock mode timing (3 V devices)	102
Table 52.	CPLD macrocell asynchronous clock mode timing (5 V devices)	103
Table 53.	CPLD macrocell Asynchronous clock mode timing (3 V devices)	104
Table 54.	Input macrocell timing (5 V devices)	105
Table 55.	input macrocell timing (3 V devices)	105
Table 56.	READ timing (5 V devices)	106
Table 57.	READ timing (3 V devices)	107
Table 58.	WRITE timing (5 V devices)	108
Table 59.	WRITE timing (3 V devices)	109
Table 60.	Program, WRITE and Erase times (5 V devices)	110
Table 61.	Program, WRITE and Erase times (3 V devices)	110
Table 62.	Port A Peripheral Data mode READ timing (5 V devices)	111
Table 63.	Port A Peripheral Data mode READ timing (3V devices)	112
Table 64.	Port A Peripheral Data mode WRITE timing (5 V devices)	112
Table 65.	Port A Peripheral Data mode WRITE timing (3 V devices)	113
Table 66.	Reset (RESET) timing (5 V devices)	113
Table 67.	Reset (RESET) timing (3 V devices)	113
Table 68.	ISC timing (5 V devices)	114
Table 69.	ISC timing (3 V devices)	115
Table 70.	Power-down timing (5 V devices)	115
Table 71.	Power-down timing (3 V devices)	115
Table 72.	PQFP52 - 52-pin plastic quad flat package mechanical dimensions	117
Table 73.	PLCC52-52-lead plastic lead chip carrier mechanical dimensions	118
Table 74.	TQFP64 - 64-lead thin quad flatpack, package mechanical data	119
Table 75.	Ordering information scheme	120
Table 76.	PQFP52 connections (see Features)	121
Table 77.	PLCC52 connections (see Features)	123
Table 78.	TQFP64 connections (see Features)	125
Table 79.	Document revision history	127

List of figures

Figure 1.	PQFP52 connections	12
Figure 2.	PLCC52 connections	13
Figure 3.	TQFP64 connections	14
Figure 4.	PSD block diagram	19
Figure 5.	PSDsoft Express development tool	23
Figure 6.	Data Polling flowchart	35
Figure 7.	Data Toggle flowchart	37
Figure 8.	Priority level of memory and I/O components	44
Figure 9.	8031 memory modules – separate space	44
Figure 10.	8031 memory modules – combined space	45
Figure 11.	Page register	46
Figure 12.	PLD diagram	49
Figure 13.	DPLD logic array	50
Figure 14.	Macrocell and I/O port	52
Figure 15.	CPLD Output macrocell	55
Figure 16.	Input macrocell	57
Figure 17.	Handshaking communication using input macrocells	58
Figure 18.	An example of a typical 8-bit multiplexed bus interface	60
Figure 19.	An example of a typical 8-bit non-multiplexed bus interface	61
Figure 20.	Interfacing the PSD with an 80C31	62
Figure 21.	Interfacing the PSD with the 80C251, with One READ input	63
Figure 22.	Interfacing the PSD with the 80C251, with RD and PSEN inputs	64
Figure 23.	Interfacing the PSD with the 80C51X, 8-bit data bus	65
Figure 24.	Interfacing the PSD with a 68HC11	66
Figure 25.	General I/O port architecture	68
Figure 26.	Peripheral I/O mode	71
Figure 27.	Port A and port B structure	75
Figure 28.	Port C structure	76
Figure 29.	Port D structure	77
Figure 30.	Port D external Chip Select signals	78
Figure 31.	APD unit	81
Figure 32.	Enable Power-down flowchart	82
Figure 33.	Reset (RESET) timing	86
Figure 34.	PLD ICC /frequency consumption (5 V range)	93
Figure 35.	PLD ICC /frequency consumption (3 V range)	93
Figure 36.	AC measurement I/O waveform	97
Figure 37.	AC measurement load circuit	97
Figure 38.	Switching waveforms – key	97
Figure 39.	Input to output disable / enable	100
Figure 40.	Synchronous clock mode timing – PLD	101
Figure 41.	Asynchronous Reset / Preset	103
Figure 42.	Asynchronous Clock mode Timing (product term clock)	103
Figure 43.	Input macrocell timing (product term clock)	105
Figure 44.	READ timing	106
Figure 45.	WRITE timing	108
Figure 46.	Peripheral I/O READ timing	111
Figure 47.	Peripheral I/O WRITE timing	112
Figure 48.	Reset (RESET) timing	113

Figure 49.	ISC timing	114
Figure 50.	PQFP52 - 52-pin plastic quad flat package mechanical drawing	117
Figure 51.	PLCC52 - 52-lead plastic lead chip carrier package mechanical drawing	118
Figure 52.	TQFP64 - 64-lead thin quad flatpack, package outline	119

Obsolete Product(s) - Obsolete Product(s)

1 Summary description

The PSD8XXFX family of memory systems for microcontrollers (MCUs) brings in-system-programmability (ISP) to Flash memory and programmable logic. The result is a simple and flexible solution for embedded designs. PSD devices combine many of the peripheral functions found in MCU based applications.

Table 2 summarizes all the devices.

The CPLD in the PSD devices features an optimized macrocell logic architecture. The PSD macrocell was created to address the unique requirements of embedded system designs. It allows direct connection between the system address/data bus, and the internal PSD registers, to simplify communication between the MCU and other supporting devices.

The PSD device includes a JTAG serial programming interface, to allow in-system programming (ISP) of the entire device. This feature reduces development time, simplifies the manufacturing flow, and dramatically lowers the cost of field upgrades. Using ST's special Fast-JTAG programming, a design can be rapidly programmed into the PSD in as little as seven seconds.

The innovative PSD8XXFX family solves key problems faced by designers when managing discrete Flash memory devices, such as:

- First-time in-system programming (ISP)
- Complex address decoding
- Simultaneous read and write to the device.

The JTAG Serial Interface block allows in-system programming (ISP), and eliminates the need for an external Boot EPROM, or an external programmer. To simplify Flash memory updates, program execution is performed from a secondary Flash memory while the primary Flash memory is being updated. This solution avoids the complicated hardware and software overhead necessary to implement IAP.

ST makes available a software development tool, PSDsoft™ Express, that generates ANSI-C compliant code for use with your target MCU. This code allows you to manipulate the non-volatile memory (NVM) within the PSD. Code examples are also provided for:

- Flash memory IAP via the UART of the host MCU
- Memory paging to execute code across several PSD memory pages
- Loading, reading, and manipulation of PSD macrocells by the MCU.

Table 2. Product range

Part number ⁽¹⁾	Primary Flash memory (8 sectors)	Secondary Flash memory (4 sectors)	SRAM	I/O ports	Number of macrocells		Serial ISP JTAG/ISC port	Turbo mode
					Input	Output		
PSD813F2	1 Mbit	256 Kbit	16 Kbit	27	24	16	yes	yes
PSD813F4	1 Mbit	256 Kbit	none	27	24	16	yes	yes
PSD813F5	1 Mbit	none	none	27	24	16	yes	yes
PSD833F2	1 Mbit	256 Kbit	64 Kbit	27	24	16	yes	yes
PSD834F2	2 Mbit	256 Kbit	64 Kbit	27	24	16	yes	yes

Table 2. Product range (continued)

Part number ⁽¹⁾	Primary Flash memory (8 sectors)	Secondary Flash memory (4 sectors)	SRAM	I/O ports	Number of macrocells		Serial ISP JTAG/ISC port	Turbo mode
					Input	Output		
PSD853F2	1 Mbit	256 Kbit	256 Kbit	27	24	16	yes	yes
PSD854F2	2 Mbit	256 Kbit	256 Kbit	27	24	16	yes	yes

1. All products support: JTAG serial ISP, MCU parallel ISP, ISP Flash memory, ISP CPLD, Security features, Power Management Unit (PMU), Automatic Power-down (APD)

Figure 1. PQFP52 connections

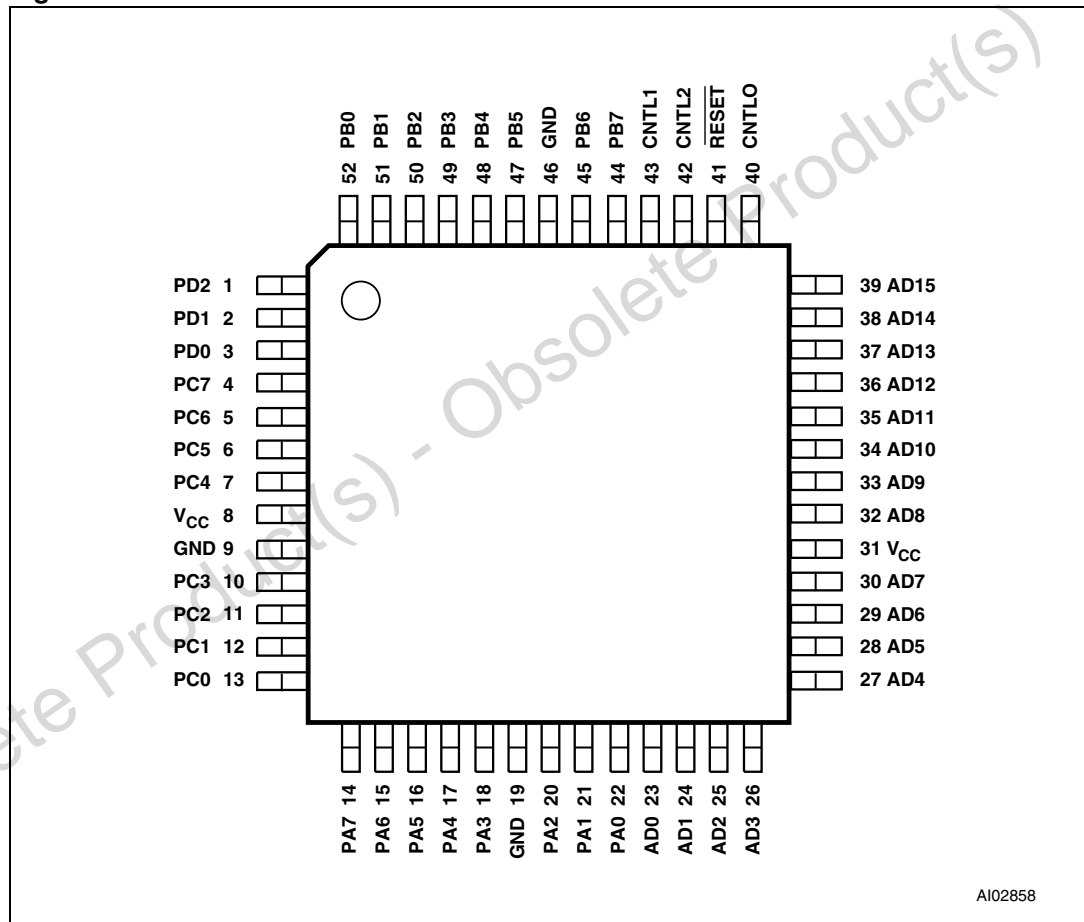

AI02858

Figure 2. PLCC52 connections

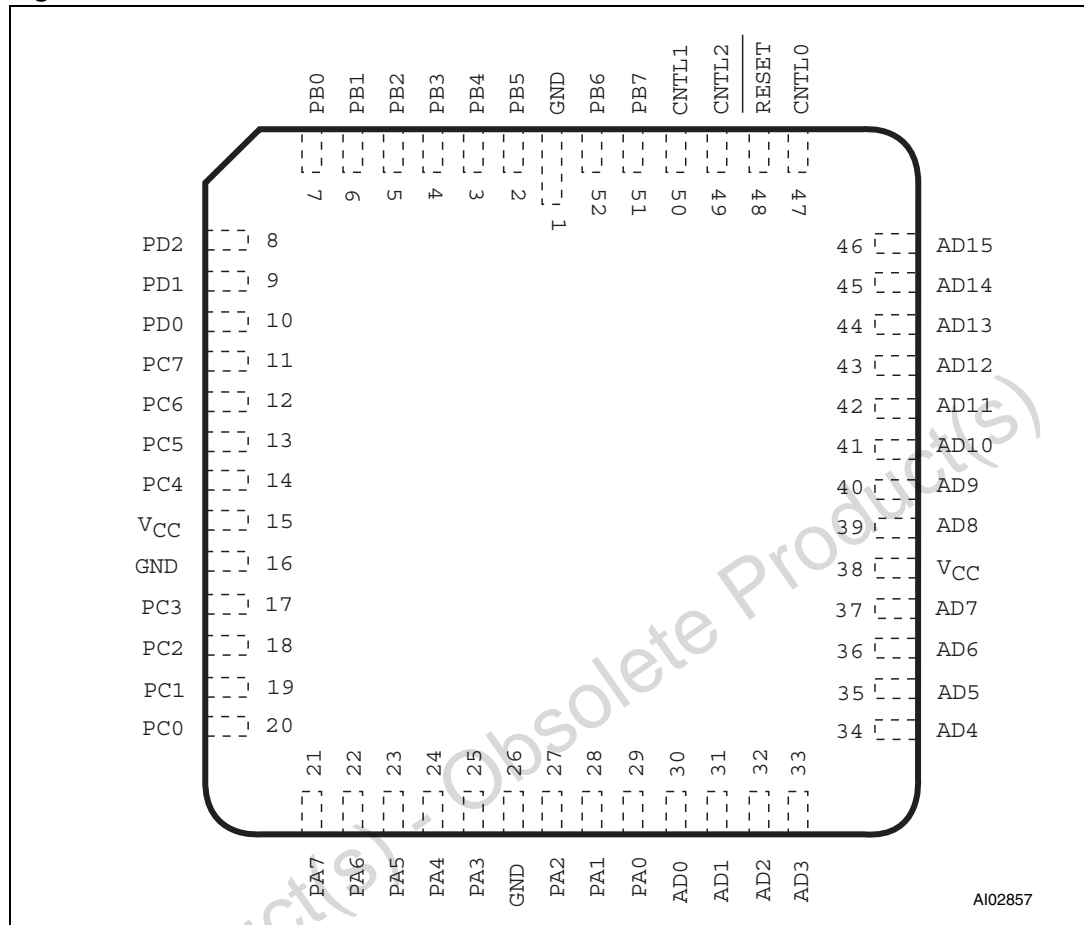
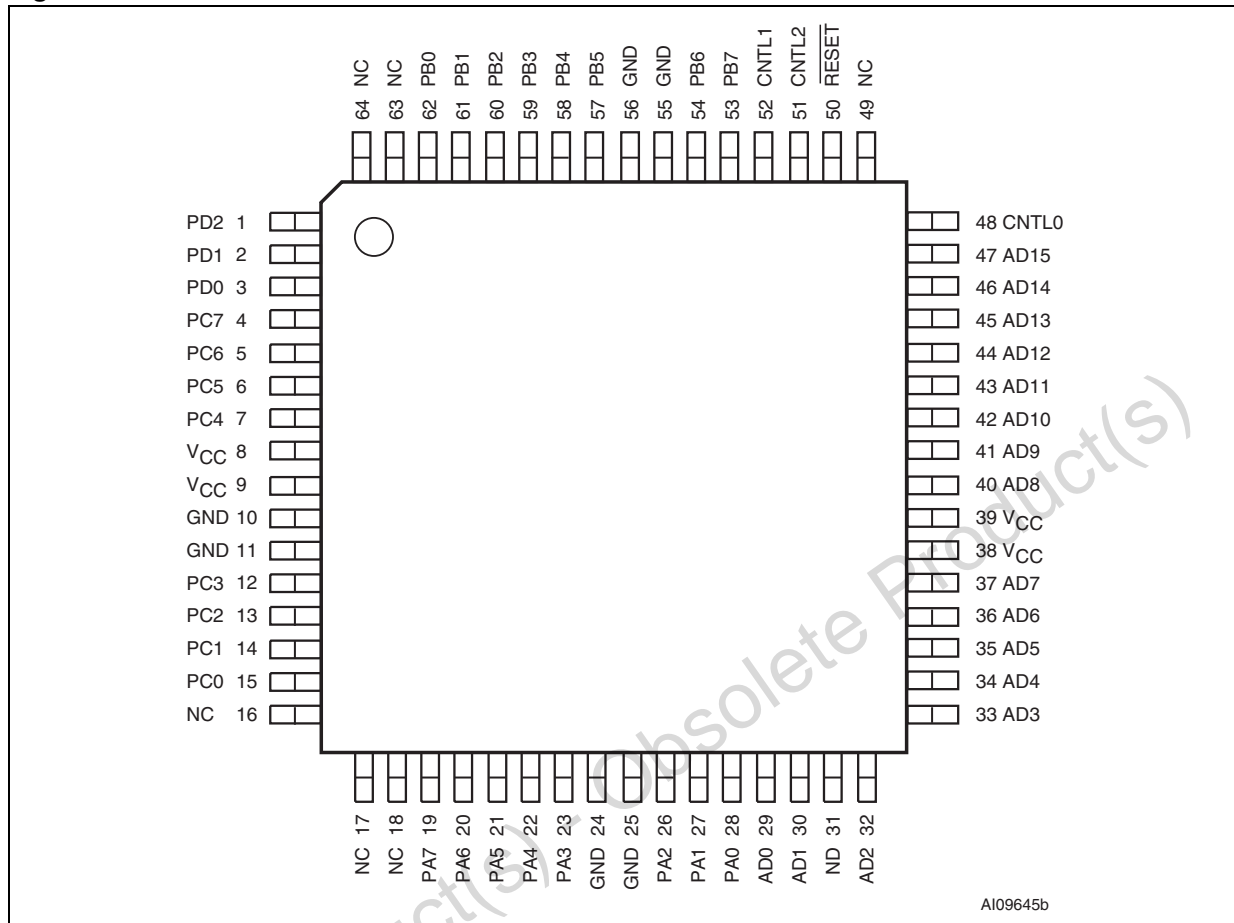

Figure 3. TQFP64 connections



2 Pin description

Table 3. PLCC52 pin description (1)

Pin name	Pin	Type	Description
ADIO0-7	30-37	I/O	<p>This is the lower Address/Data port. Connect your MCU address or address/data bus according to the following rules:</p> <p>If your MCU has a multiplexed address/data bus where the data is multiplexed with the lower address bits, connect AD0-AD7 to this port.</p> <p>If your MCU does not have a multiplexed address/data bus, or you are using an 80C251 in page mode, connect A0-A7 to this port.</p> <p>If you are using an 80C51XA in burst mode, connect A4/D0 through A11/D7 to this port. ALE or AS latches the address. The PSD drives data out only if the READ signal is active and one of the PSD functional blocks was selected. The addresses on this port are passed to the PLDs.</p>
ADIO8-15	39-46	I/O	<p>This is the upper Address/Data port. Connect your MCU address or address/data bus according to the following rules:</p> <p>If your MCU has a multiplexed address/data bus where the data is multiplexed with the lower address bits, connect A8-A15 to this port.</p> <p>If your MCU does not have a multiplexed address/data bus, connect A8-A15 to this port.</p> <p>If you are using an 80C251 in page mode, connect AD8-AD15 to this port.</p> <p>If you are using an 80C51XA in burst mode, connect A12/D8 through A19/D15 to this port.</p> <p>ALE or AS latches the address. The PSD drives data out only if the READ signal is active and one of the PSD functional blocks was selected. The addresses on this port are passed to the PLDs.</p>
CNTL0	47	I	<p>The following control signals can be connected to this port, based on your MCU:</p> <p>\overline{WR} – active low Write Strobe input.</p> <p>R_W – active high READ/active low write input.</p> <p>This port is connected to the PLDs. Therefore, these signals can be used in decode and other logic equations.</p>
CNTL1	50	I	<p>The following control signals can be connected to this port, based on your MCU:</p> <p>\overline{RD} – active low Read Strobe input.</p> <p>E – E clock input.</p> <p>\overline{DS} – active low Data Strobe input.</p> <p>\overline{PSEN} – connect \overline{PSEN} to this port when it is being used as an active low READ signal. For example, when the 80C251 outputs more than 16 address bits, \overline{PSEN} is actually the READ signal.</p> <p>This port is connected to the PLDs. Therefore, these signals can be used in decode and other logic equations.</p>
CNTL2	49	I	<p>This port can be used to input the \overline{PSEN} (Program Select Enable) signal from any MCU that uses this signal for code exclusively. If your MCU does not output a Program Select Enable signal, this port can be used as a generic input. This port is connected to the PLDs.</p>
Reset	48	I	<p>Resets I/O ports, PLD macrocells and some of the Configuration registers. Must be low at Power-up.</p>

Table 3. PLCC52 pin description ⁽¹⁾ (continued)

Pin name	Pin	Type	Description
PA0 PA1 PA2 PA3 PA4 PA5 PA6 PA7	29 28 27 25 24 23 22 21	I/O	<p>These pins make up port A. These port pins are configurable and can have the following functions:</p> <p>MCU I/O – write to or read from a standard output or input port.</p> <p>CPLD macrocell (McellAB0-7) outputs.</p> <p>Inputs to the PLDs.</p> <p>Latched address outputs (see Table 7).</p> <p>Address inputs. For example, PA0-3 could be used for A0-A3 when using an 80C51XA in burst mode.</p> <p>As the data bus inputs D0-D7 for non-multiplexed address/data bus MCUs.</p> <p>D0/A16-D3/A19 in M37702M2 mode.</p> <p>Peripheral I/O mode.</p> <p><i>Note: PA0-PA3 can only output CMOS signals with an option for high slew rate. However, PA4-PA7 can be configured as CMOS or Open Drain outputs.</i></p>
PB0 PB1 PB2 PB3 PB4 PB5 PB6 PB7	7 6 5 4 3 2 52 51	I/O	<p>These pins make up port B. These port pins are configurable and can have the following functions:</p> <p>MCU I/O – write to or read from a standard output or input port.</p> <p>CPLD macrocell (McellAB0-7 or McellBC0-7) outputs.</p> <p>Inputs to the PLDs.</p> <p>Latched address outputs (see Table 7).</p> <p><i>Note: PB0-PB3 can only output CMOS signals with an option for high slew rate. However, PB4-PB7 can be configured as CMOS or Open Drain outputs.</i></p>
PC0	20	I/O	<p>PC0 pin of port C. This port pin can be configured to have the following functions:</p> <p>MCU I/O – write to or read from a standard output or input port.</p> <p>CPLD macrocell (McellBC0) output.</p> <p>Input to the PLDs.</p> <p>TMS input⁽²⁾ for the JTAG Serial Interface.</p> <p>This pin can be configured as a CMOS or Open Drain output.</p>
PC1	19	I/O	<p>PC1 pin of port C. This port pin can be configured to have the following functions:</p> <p>MCU I/O – write to or read from a standard output or input port.</p> <p>CPLD macrocell (McellBC1) output.</p> <p>Input to the PLDs.</p> <p>TCK input⁽²⁾ for the JTAG Serial Interface.</p> <p>This pin can be configured as a CMOS or Open Drain output.</p>
PC2	18	I/O	<p>PC2 pin of port C. This port pin can be configured to have the following functions:</p> <p>MCU I/O – write to or read from a standard output or input port.</p> <p>CPLD macrocell (McellBC2) output.</p> <p>Input to the PLDs.</p> <p>This pin can be configured as a CMOS or Open Drain output.</p>

Table 3. PLCC52 pin description ⁽¹⁾ (continued)

Pin name	Pin	Type	Description
PC3	17	I/O	PC3 pin of port C. This port pin can be configured to have the following functions: MCU I/O – write to or read from a standard output or input port. CPLD macrocell (McellBC3) output. Input to the PLDs. $\overline{\text{TSTAT}}$ output ⁽²⁾ for the JTAG Serial Interface. Ready/ $\overline{\text{Busy}}$ output for parallel in-system programming (ISP). This pin can be configured as a CMOS or Open Drain output.
PC4	14	I/O	PC4 pin of port C. This port pin can be configured to have the following functions: MCU I/O – write to or read from a standard output or input port. CPLD macrocell (McellBC4) output. Input to the PLDs. $\overline{\text{TERR}}$ output ⁽²⁾ for the JTAG Serial Interface. This pin can be configured as a CMOS or Open Drain output.
PC5	13	I/O	PC5 pin of port C. This port pin can be configured to have the following functions: MCU I/O – write to or read from a standard output or input port. CPLD macrocell (McellBC5) output. Input to the PLDs. TDI input ⁽²⁾ for the JTAG Serial Interface. This pin can be configured as a CMOS or Open Drain output.
PC6	12	I/O	PC6 pin of port C. This port pin can be configured to have the following functions: MCU I/O – write to or read from a standard output or input port. CPLD macrocell (McellBC6) output. Input to the PLDs. TDO output ⁽²⁾ for the JTAG Serial Interface. This pin can be configured as a CMOS or Open Drain output.
PC7	11	I/O	PC7 pin of port C. This port pin can be configured to have the following functions: MCU I/O – write to or read from a standard output or input port. CPLD macrocell (McellBC7) output. Input to the PLDs. DBE – active low Data Byte Enable input from 68HC912 type MCUs. This pin can be configured as a CMOS or Open Drain output.
PD0	10	I/O	PD0 pin of port D. This port pin can be configured to have the following functions: ALE/AS input latches address output from the MCU. MCU I/O – write or read from a standard output or input port. Input to the PLDs. CPLD output (External Chip Select).
PD1	9	I/O	PD1 pin of port D. This port pin can be configured to have the following functions: MCU I/O – write to or read from a standard output or input port. Input to the PLDs. CPLD output (External Chip Select). CLKIN – clock input to the CPLD macrocells, the APD Unit's Power-down counter, and the CPLD AND Array.

Table 3. PLCC52 pin description ⁽¹⁾ (continued)

Pin name	Pin	Type	Description
PD2	8	I/O	PD2 pin of port D. This port pin can be configured to have the following functions: MCU I/O - write to or read from a standard output or input port. Input to the PLDs. CPLD output (External Chip Select). PSD Chip Select input ($\overline{\text{CSI}}$). When low, the MCU can access the PSD memory and I/O. When high, the PSD memory blocks are disabled to conserve power.
V _{CC}	15, 38		Supply voltage
GND	1, 16, 26		Ground pins

1. The pin numbers in this table are for the PLCC package only. See the package information from [Table 73](#) onwards, for pin numbers on other package types.
2. These functions can be multiplexed with other functions.

Figure 4. PSD block diagram

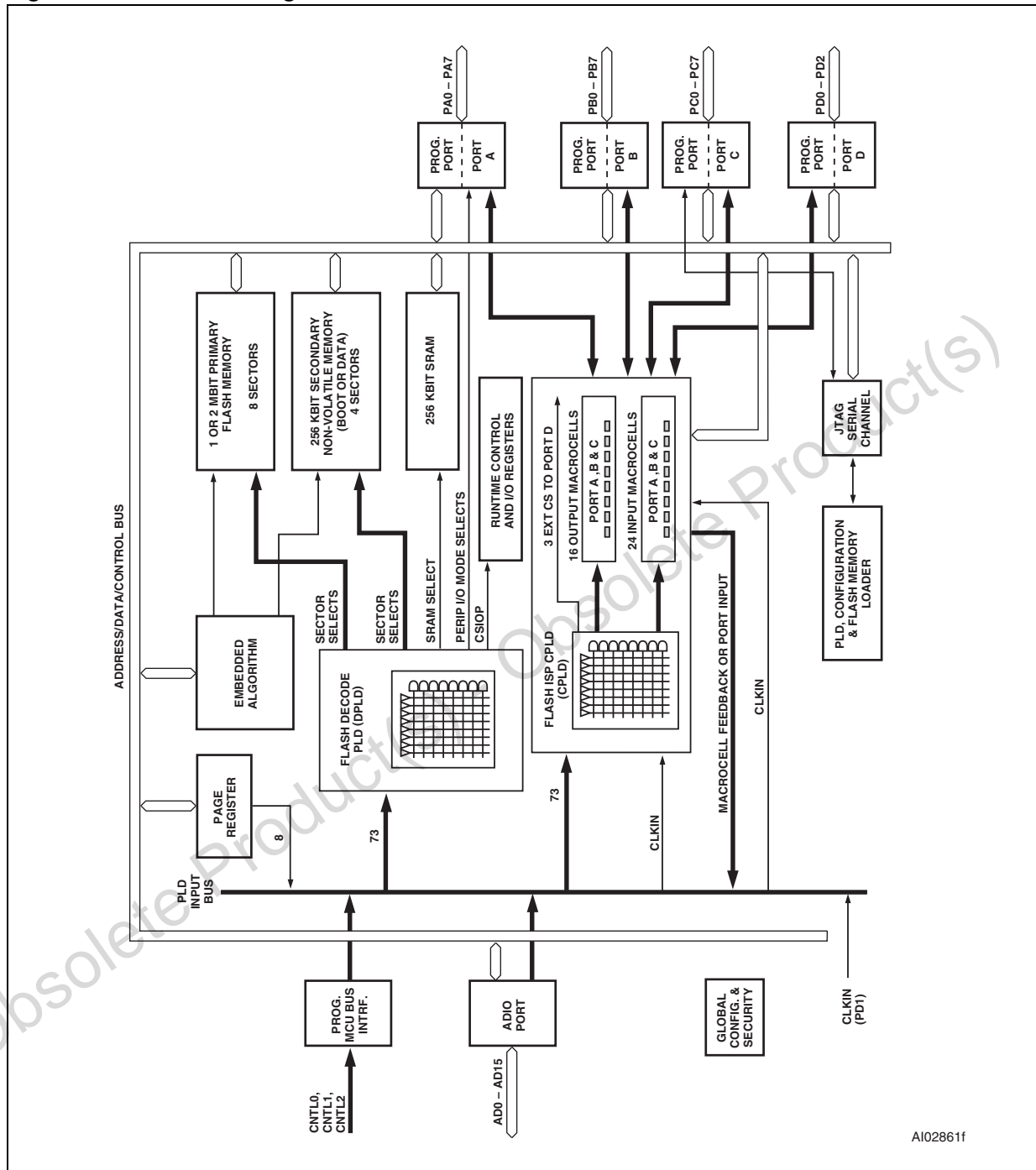

3 PSD architectural overview

PSD devices contain several major functional blocks. [Figure 4](#) shows the architecture of the PSD device family. The functions of each block are described briefly in the following sections. Many of the blocks perform multiple functions and are user configurable.

3.1 Memory

Each of the memory blocks is briefly discussed in the following paragraphs. A more detailed discussion can be found in [Section 6.1: Memory blocks](#).

The 1 Mbit or 2 Mbit (128K x 8, or 256K x 8) Flash memory is the primary memory of the PSD. It is divided into 8 equally-sized sectors that are individually selectable.

The optional 256 Kbit (32K x 8) secondary Flash memory is divided into 4 equally-sized sectors. Each sector is individually selectable.

The optional SRAM is intended for use as a scratch-pad memory or as an extension to the MCU SRAM.

Each sector of memory can be located in a different address space as defined by the user. The access times for all memory types includes the address latching and DPLD decoding time.

3.2 Page register

The 8-bit Page register expands the address range of the MCU by up to 256 times. The paged address can be used as part of the address space to access external memory and peripherals, or internal memory and I/O. The Page register can also be used to change the address mapping of sectors of the Flash memories into different memory spaces for IAP.

3.3 PLDs

The device contains two PLDs, the Decode PLD (DPLD) and the Complex PLD (CPLD), as shown in [Table 4](#), each optimized for a different function. The functional partitioning of the PLDs reduces power consumption, optimizes cost/performance, and eases design entry.

The DPLD is used to decode addresses and to generate Sector Select signals for the PSD internal memory and registers. The DPLD has combinatorial outputs. The CPLD has 16 Output macrocells (OMC) and 3 combinatorial outputs. The PSD also has 24 input macrocells (IMC) that can be configured as inputs to the PLDs. The PLDs receive their inputs from the PLD input bus and are differentiated by their output destinations, number of product terms, and macrocells.

The PLDs consume minimal power. The speed and power consumption of the PLD is controlled by the Turbo Bit in PMMR0 and other bits in the PMMR2. These registers are set by the MCU at run-time. There is a slight penalty to PLD propagation time when invoking the power management features.

3.4 I/O ports

The PSD has 27 individually configurable I/O pins distributed over the four ports (Port A, B, C, and D). Each I/O pin can be individually configured for different functions. ports can be configured as standard MCU I/O ports, PLD I/O, or latched address outputs for MCUs using multiplexed address/data buses.

The JTAG pins can be enabled on port C for in-system programming (ISP).

Ports A and B can also be configured as a data port for a non-multiplexed bus.

3.5 MCU bus interface

PSD interfaces easily with most 8-bit MCUs that have either multiplexed or non-multiplexed address/data buses. The device is configured to respond to the MCU control signals, which are also used as inputs to the PLDs. For examples, please see [Section 15.4: MCU bus interface examples](#).

Table 4. PLD I/O

Name	Inputs	Outputs	Product terms
Decode PLD (DPLD)	73	17	42
Complex PLD (CPLD)	73	19	140

3.6 JTAG port

In-system programming (ISP) can be performed through the JTAG signals on port C. This serial interface allows complete programming of the entire PSD device. A blank device can be completely programmed. The JTAG signals (TMS, TCK, TSTAT, TERR, TDI, TDO) can be multiplexed with other functions on port C. [Table 5](#) indicates the JTAG pin assignments.

3.7 In-system programming (ISP)

Using the JTAG signals on port C, the entire PSD device can be programmed or erased without the use of the MCU. The primary Flash memory can also be programmed in-system by the MCU executing the programming algorithms out of the secondary memory, or SRAM. The secondary memory can be programmed the same way by executing out of the primary Flash memory. The PLD or other PSD configuration blocks can be programmed through the JTAG port or a device programmer. [Table 6](#) indicates which programming methods can program different functional blocks of the PSD.

3.8 Power management unit (PMU)

The power management unit (PMU) gives the user control of the power consumption on selected functional blocks based on system requirements. The PMU includes an Automatic Power-down (APD) Unit that turns off device functions during MCU inactivity. The APD unit has a Power-down mode that helps reduce power consumption.

The PSD also has some bits that are configured at run-time by the MCU to reduce power consumption of the CPLD. The Turbo Bit in PMMR0 can be reset to '0' and the CPLD latches its outputs and goes to sleep until the next transition on its inputs.

Additionally, bits in PMMR2 can be set by the MCU to block signals from entering the CPLD to reduce power consumption. Please see [Section 17: Power management](#) for more details.

Table 5. JTAG Signals on port C

Port C pins	JTAG signal
PC0	TMS
PC1	TCK
PC3	$\overline{\text{TSTAT}}$
PC4	$\overline{\text{TERR}}$
PC5	TDI
PC6	TDO

Table 6. Methods for programming different functional blocks of the PSD

Functional block	JTAG programming	Device programmer	IAP
Primary Flash memory	Yes	Yes	Yes
Secondary Flash memory	Yes	Yes	Yes
PLD array (DPLD and CPLD)	Yes	Yes	No
PSD configuration	Yes	Yes	No

4 Development system

The PSD8XXFX family is supported by PSDsoft Express, a Windows-based software development tool. A PSD design is quickly and easily produced in a point and click environment. The designer does not need to enter Hardware Description Language (HDL) equations, unless desired, to define PSD pin functions and memory map information. The general design flow is shown in *Figure 5*. PSDsoft Express is available from our web site (the address is given on the back page of this data sheet) or other distribution channels.

PSDsoft Express directly supports two low cost device programmers from ST: PSDpro and FlashLINK (JTAG). Both of these programmers may be purchased through your local distributor/representative, or directly from our web site using a credit card. The PSD is also supported by third party device programmers. See our web site for the current list.

Figure 5. PSDsoft Express development tool

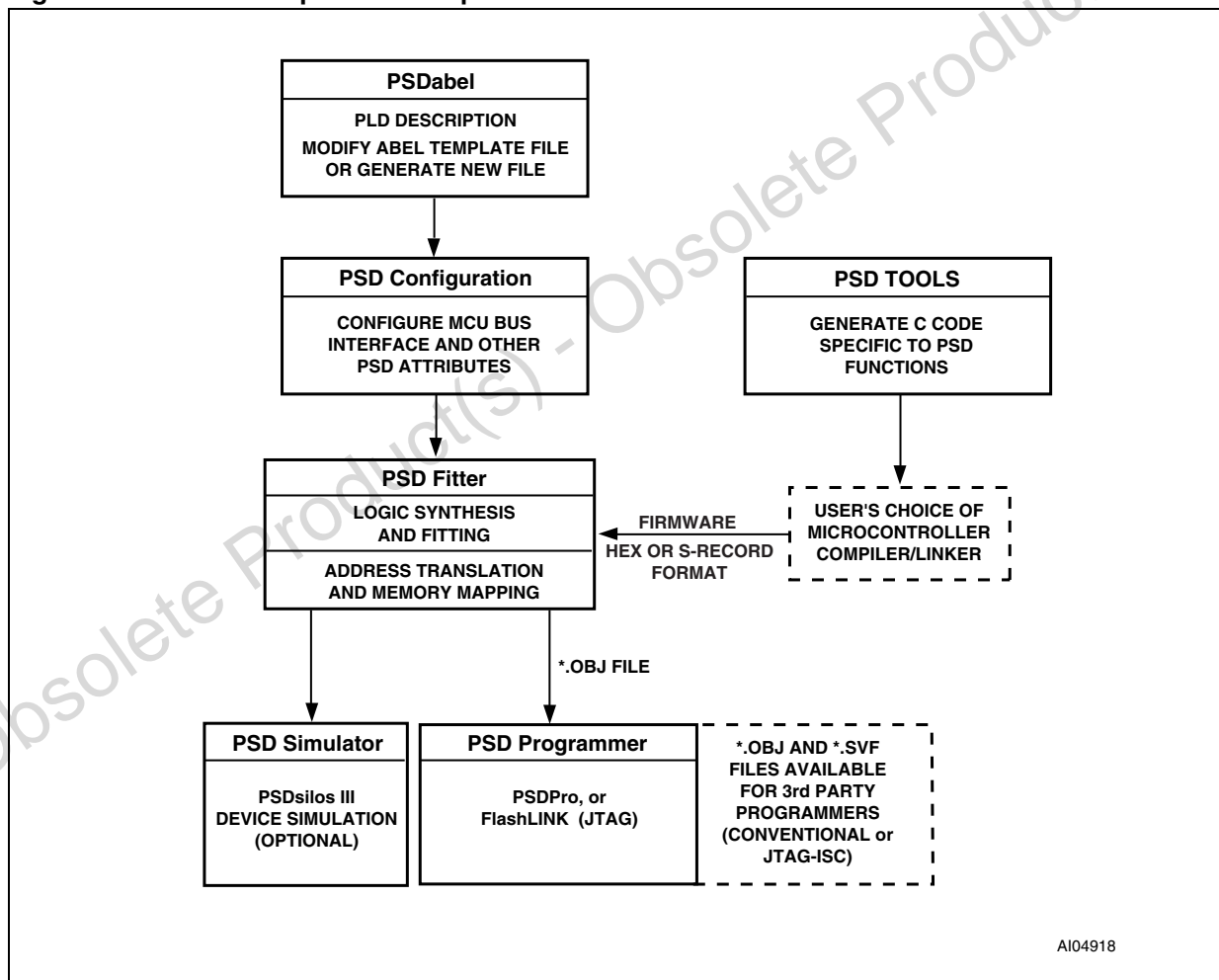

AI04918

5 PSD register description and address offset

Table 7 shows the offset addresses to the PSD registers relative to the CSIOP base address. The CSIOP space is the 256 bytes of address that is allocated by the user to the internal PSD registers. Table 8 provides brief descriptions of the registers in CSIOP space. The following section gives a more detailed description.

Table 7. I/O port latched address output assignments⁽¹⁾⁽²⁾

MCU	Port A		Port B	
	Port A (3:0)	Port A (7:4)	Port B (3:0)	Port B (7:4)
8051XA (8-bit)	N/A	Address a7-a4	Address a11-a8	N/A
80C251 (page mode)	N/A	N/A	Address a11-a8	Address a15-a12
All other 8-bit multiplexed	Address a3-a0	Address a7-a4	Address a3-a0	Address a7-a4
8-bit non-multiplexed bus	N/A	N/A	Address a3-a0	Address a7-a4

1. See Section 16: I/O ports, on how to enable the Latched Address Output function.
2. N/A = Not Applicable

Table 8. Register address offset

Register name	Port A	Port B	Port C	Port D	Other (1)	Description
Data In	00	01	10	11		Reads port pin as input, MCU I/O input mode
Control	02	03				Selects mode between MCU I/O or Address Out
Data Out	04	05	12	13		Stores data for output to port pins, MCU I/O output mode
Direction	06	07	14	15		Configures port pin as input or output
Drive Select	08	09	16	17		Configures port pins as either CMOS or Open Drain on some pins, while selecting high slew rate on other pins.
Input macrocell	0A	0B	18			Reads input macrocells
Enable Out	0C	0D	1A	1B		Reads the status of the output enable to the I/O port driver
Output macrocells AB	20	20				READ – reads output of macrocells AB WRITE – loads macrocell flip-flops
Output macrocells BC		21	21			READ – reads output of macrocells BC WRITE – loads macrocell flip-flops

Table 8. Register address offset (continued)

Register name	Port A	Port B	Port C	Port D	Other (1)	Description
Mask macrocells AB	22	22				Blocks writing to the Output macrocells AB
Mask macrocells BC		23	23			Blocks writing to the Output macrocells BC
Primary Flash Protection					C0	Read only – Primary Flash Sector Protection
Secondary Flash memory Protection					C2	Read only – PSD Security and Secondary Flash memory Sector Protection
JTAG Enable					C7	Enables JTAG port
PMMR0					B0	Power Management register 0
PMMR2					B4	Power Management register 2
Page					E0	Page register
VM					E2	Places PSD memory areas in program and/or data space on an individual basis.

1. Other registers that are not part of the I/O ports.

6 Detailed operation

As shown in [Figure 4](#), the PSD consists of six major types of functional blocks:

- Memory blocks
- PLD blocks
- MCU bus interface
- I/O ports
- Power management unit (PMU)
- JTAG interface

The functions of each block are described in the following sections. Many of the blocks perform multiple functions, and are user configurable.

6.1 Memory blocks

The PSD has the following memory blocks:

- Primary Flash memory
- Optional Secondary Flash memory
- Optional SRAM

The Memory Select signals for these blocks originate from the Decode PLD (DPLD) and are user-defined in PSDsoft Express.

Table 9. Memory block size and organization

Sector number	Primary Flash memory		Secondary Flash memory		SRAM	
	Sector size (Kbytes)	Sector select signal	Sector size (Kbytes)	Sector select signal	SRAM size (Kbytes)	SRAM select signal
0	32	FS0	16	CSBOOT0	256	RS0
1	32	FS1	16	CSBOOT1		
2	32	FS2	16	CSBOOT2		
3	32	FS3	16	CSBOOT3		
4	32	FS4				
5	32	FS5				
6	32	FS6				
7	32	FS7				
Total	512	8 sectors	64	4 sectors	256	

6.2 Description of primary Flash memory and secondary Flash memory

The primary Flash memory is divided evenly into eight equal sectors. The secondary Flash memory is divided into four equal sectors. Each sector of either memory block can be separately protected from Program and Erase cycles.

Flash memory may be erased on a sector-by-sector basis. Flash sector erasure may be suspended while data is read from other sectors of the block and then resumed after reading.

During a program or erase cycle in Flash memory, the status can be output on Ready/ $\overline{\text{Busy}}$ (PC3). This pin is set up using PSDsoft Express Configuration.

6.3 Memory block select signals

The DPLD generates the Select signals for all the internal memory blocks (see [Section 14: PLDS](#)). Each of the eight sectors of the primary Flash memory has a Select signal (FS0-FS7) which can contain up to three product terms. Each of the four sectors of the secondary Flash memory has a Select signal (CSBOOT0-CSBOOT3) which can contain up to three product terms. Having three product terms for each Select signal allows a given sector to be mapped in different areas of system memory. When using a MCU with separate program and data space, these flexible Select signals allow dynamic re-mapping of sectors from one memory space to the other.

6.3.1 Ready/ $\overline{\text{Busy}}$ (PC3)

This signal can be used to output the Ready/ $\overline{\text{Busy}}$ status of the PSD. The output on Ready/ $\overline{\text{Busy}}$ (PC3) is a 0 (Busy) when Flash memory is being written to, *or* when Flash memory is being erased. The output is a 1 (Ready) when no WRITE or Erase cycle is in progress.

6.3.2 Memory operation

The primary Flash memory and secondary Flash memory are addressed through the MCU bus interface. The MCU can access these memories in one of two ways:

- The MCU can execute a typical bus WRITE or READ *operation* just as it would if accessing a RAM or ROM device using standard bus cycles.
- The MCU can execute a specific instruction that consists of several WRITE and READ operations. This involves writing specific data patterns to special addresses within the Flash memory to invoke an embedded algorithm. These instructions are summarized in [Table 10](#).

Typically, the MCU can read Flash memory using READ operations, just as it would read a ROM device. However, Flash memory can only be altered using specific Erase and Program instructions. For example, the MCU cannot write a single byte directly to Flash memory as it would write a byte to RAM. To program a byte into Flash memory, the MCU must execute a Program instruction, then test the status of the Program cycle. This status test is achieved by a READ operation or polling Ready/ $\overline{\text{Busy}}$ (PC3).

Flash memory can also be read by using special instructions to retrieve particular Flash device information (sector protect status and ID).

Table 10. Instructions (1)(2)(3)

Instruction	FS0-FS7 or CSBOOT0-CSBOOT3 (4)	Cycle 1	Cycle 2	Cycle 3	Cycle 4	Cycle 5	Cycle 6	Cycle 7
READ ⁽⁵⁾	1	"READ" RD @ RA						
Read Main Flash ID ⁽⁶⁾	1	AAh@ X555h	55h@ XAAAh	90h@ X555h	Read identifier (A6,A1,A0 = 0,0,1)			
Read Sector Protection ⁽⁶⁾⁽⁷⁾ (8)	1	AAh@ X555h	55h@ XAAAh	90h@ X555h	Read identifier (A6,A1,A0 = 0,1,0)			
Program a Flash Byte ⁽⁸⁾	1	AAh@ X555h	55h@ XAAAh	A0h@ X555h	PD@ PA			
Flash Sector Erase ⁽⁹⁾⁽⁸⁾	1	AAh@ X555h	55h@ XAAAh	80h@ X555h	AAh@ X555h	55h@ XAAAh	30h@ SA	30h ⁷ @ next SA
Flash Bulk Erase ⁽⁸⁾	1	AAh@ X555h	55h@ XAAAh	80h@ X555h	AAh@ X555h	55h@ XAAAh	10h@ X555h	
Suspend Sector Erase ⁽¹⁰⁾	1	B0h@ XXXXh						
Resume Sector Erase ⁽¹¹⁾	1	30h@ XXXXh						
Reset ⁽⁶⁾	1	F0h@ XXXXh						
Unlock Bypass	1	AAh@ X555h	55h@ XAAAh	20h@ X555h				
Unlock Bypass Program ⁽¹²⁾	1	A0h@ XXXXh	PD@ PA					
Unlock Bypass Reset ⁽¹³⁾	1	90h@ XXXXh	00h@ XXXXh					

- All bus cycles are WRITE bus cycles, except the ones with the "READ" label
- All values are in hexadecimal:
 X = Don't Care. Addresses of the form XXXXh, in this table, must be even addresses
 RA = Address of the memory location to be read
 RD = Data read from location RA during the READ cycle
 PA = Address of the memory location to be programmed. Addresses are latched on the falling edge of Write Strobe (\overline{WR} , CNTL0). PA is an even address for PSD in word programming mode.
 PD = Data word to be programmed at location PA. Data is latched on the rising edge of Write Strobe (\overline{WR} , CNTL0)
 SA = Address of the sector to be erased or verified. The Sector Select (FS0-FS7 or CSBOOT0-CSBOOT3) of the sector to be erased, or verified, must be Active (high).
- Only address bits A11-A0 are used in instruction decoding.
- Sector Select (FS0 to FS7 or CSBOOT0 to CSBOOT3) signals are active high, and are defined in PSDsoft Express.
- No Unlock or instruction cycles are required when the device is in the READ mode
- The Reset instruction is required to return to the READ mode after reading the Flash ID, or after reading the Sector Protection Status, or if the Error flag bit (DQ5/DQ13) goes high.
- The data is 00h for an unprotected sector, and 01h for a protected sector. In the fourth cycle, the Sector Select is active, and (A1,A0)=(1,0)

8. The MCU cannot invoke these instructions while executing code from the same Flash memory as that for which the instruction is intended. The MCU must fetch, for example, the code from the secondary Flash memory when reading the Sector Protection Status of the primary Flash memory.
9. Additional sectors to be erased must be written at the end of the Sector Erase instruction within 80 μ s.
10. The system may perform READ and Program cycles in non-erasing sectors, read the Flash ID or read the Sector Protection Status when in the Suspend Sector Erase mode. The Suspend Sector Erase instruction is valid only during a Sector Erase cycle.
11. The Resume Sector Erase instruction is valid only during the Suspend Sector Erase mode.
12. The Unlock Bypass instruction is required prior to the Unlock Bypass Program instruction.
13. The Unlock Bypass Reset Flash instruction is required to return to reading memory data when the device is in the Unlock Bypass mode.

Obsolete Product(s) - Obsolete Product(s)

7 Instructions

An instruction consists of a sequence of specific operations. Each received byte is sequentially decoded by the PSD and not executed as a standard WRITE operation. The instruction is executed when the correct number of bytes are properly received and the time between two consecutive bytes is shorter than the timeout period. Some instructions are structured to include READ operations after the initial WRITE operations.

The instruction must be followed exactly. Any invalid combination of instruction bytes or timeout between two consecutive bytes while addressing Flash memory resets the device logic into READ mode (Flash memory is read like a ROM device).

The PSD supports the instructions summarized in [Table 10](#):

Flash memory:

- Erase memory by chip or sector
- Suspend or resume sector erase
- Program a Byte
- Reset to READ mode
- Read primary Flash Identifier value
- Read Sector Protection Status
- Bypass (on the PSD833F2, PSD834F2, PSD853F2 and PSD854F2)

These instructions are detailed in [Table 10](#). For efficient decoding of the instructions, the first two bytes of an instruction are the coded cycles and are followed by an instruction byte or confirmation byte. The coded cycles consist of writing the data AAh to address X555h during the first cycle and data 55h to address XAAAh during the second cycle. Address signals A15-A12 are Don't Care during the instruction WRITE cycles. However, the appropriate Sector Select (FS0-FS7 or CSBOOT0-CSBOOT3) must be selected.

The primary and secondary Flash memories have the same instruction set (except for Read Primary Flash Identifier). The Sector Select signals determine which Flash memory is to receive and execute the instruction. The primary Flash memory is selected if any one of Sector Select (FS0-FS7) is high, and the secondary Flash memory is selected if any one of Sector Select (CSBOOT0-CSBOOT3) is high.

7.1 Power-up mode

The PSD internal logic is reset upon Power-up to the READ mode. Sector Select (FS0-FS7 and CSBOOT0-CSBOOT3) must be held low, and Write Strobe (WR, CNTL0) high, during Power-up for maximum security of the data contents and to remove the possibility of a byte being written on the first edge of Write Strobe (WR, CNTL0). Any WRITE cycle initiation is locked when V_{CC} is below V_{LKO} .

7.2 READ

Under typical conditions, the MCU may read the primary Flash memory or the secondary Flash memory using READ operations just as it would a ROM or RAM device. Alternately, the MCU may use READ operations to obtain status information about a program or erase

cycle that is currently in progress. Lastly, the MCU may use instructions to read special data from these memory blocks. The following sections describe these READ functions.

7.3 Read memory contents

Primary Flash memory and secondary Flash memory are placed in the READ mode after Power-up, chip reset, or a Reset Flash instruction (see [Table 10](#)). The MCU can read the memory contents of the primary Flash memory or the secondary Flash memory by using READ operations any time the READ operation is not part of an instruction.

7.4 Read Primary Flash Identifier

The primary Flash memory identifier is read with an instruction composed of 4 operations: 3 specific WRITE operations and a READ operation (see [Table 10](#)). During the READ operation, address bits A6, A1, and A0 must be '0,0,1,' respectively, and the appropriate Sector Select (FS0-FS7) must be high. The identifier for the PSD813F2/3/4/5 is E4h, and for the PSD83xF2 or PSD85xF2 it is E7h.

7.5 Read Memory Sector Protection status

The primary Flash memory Sector Protection Status is read with an instruction composed of 4 operations: 3 specific WRITE operations and a READ operation (see [Table 10](#)). During the READ operation, address Bits A6, A1, and A0 must be '0,1,0,' respectively, while Sector Select (FS0-FS7 or CSBOOT0-CSBOOT3) designates the Flash memory sector whose protection has to be verified. The READ operation produces 01h if the Flash memory sector is protected, or 00h if the sector is not protected.

The sector protection status for all NVM blocks (primary Flash memory or secondary Flash memory) can also be read by the MCU accessing the Flash Protection registers in PSD I/O space. See [Section 10.1: Flash Memory Sector Protect](#) for register definitions.

7.6 Reading the Erase/Program Status bits

The PSD provides several status bits to be used by the MCU to confirm the completion of an Erase or Program cycle of Flash memory. These status bits minimize the time that the MCU spends performing these tasks and are defined in [Table 11](#). The status bits can be read as many times as needed.

For Flash memory, the MCU can perform a READ operation to obtain these status bits while an Erase or Program instruction is being executed by the embedded algorithm. See [Section 8: Programming Flash memory](#) for details.

Table 11. Status bits⁽¹⁾⁽²⁾⁽³⁾

Functional block	FS0-FS7/CSBOOT0-CSBOOT3	DQ7	DQ6	DQ5	DQ4	DQ3	DQ2	DQ1	DQ0
Flash memory	V _{IH}	Data Polling	Toggle flag	Error flag	X	Erase timeout	X	X	X

1. X = Not guaranteed value, can be read either '1' or '0.'
2. DQ7-DQ0 represent the data bus bits, D7-D0.
3. FS0-FS7 and CSBOOT0-CSBOOT3 are active high.

7.7 Data Polling flag (DQ7)

When erasing or programming in Flash memory, the Data Polling flag bit (DQ7) outputs the complement of the bit being entered for programming/writing on the DQ7 Bit. Once the Program instruction or the WRITE operation is completed, the true logic value is read on the Data Polling flag bit (DQ7, in a READ operation).

- Data Polling is effective after the fourth WRITE pulse (for a Program instruction) or after the sixth WRITE pulse (for an Erase instruction). It must be performed at the address being programmed or at an address within the Flash memory sector being erased.
- During an Erase cycle, the Data Polling flag bit (DQ7) outputs a '0.' After completion of the cycle, the Data Polling flag bit (DQ7) outputs the last bit programmed (it is a '1' after erasing).
- If the byte to be programmed is in a protected Flash memory sector, the instruction is ignored.
- If all the Flash memory sectors to be erased are protected, the Data Polling flag bit (DQ7) is reset to '0' for about 100µs, and then returns to the previous addressed byte. No erasure is performed.

7.8 Toggle flag (DQ6)

The PSD offers another way for determining when the Flash memory Program cycle is completed. During the internal WRITE operation and when either the FS0-FS7 or CSBOOT0-CSBOOT3 is true, the Toggle flag bit (DQ6) toggles from '0' to '1' and '1' to '0' on subsequent attempts to read any byte of the memory.

When the internal cycle is complete, the toggling stops and the data read on the data bus D0-D7 is the addressed memory byte. The device is now accessible for a new READ or WRITE operation. The cycle is finished when two successive READs yield the same output data.

- The Toggle flag bit (DQ6) is effective after the fourth WRITE pulse (for a Program instruction) or after the sixth WRITE pulse (for an Erase instruction).
- If the byte to be programmed belongs to a protected Flash memory sector, the instruction is ignored.
- If all the Flash memory sectors selected for erasure are protected, the Toggle flag bit (DQ6) toggles to '0' for about 100µs and then returns to the previous addressed byte.

7.9 Error flag (DQ5)

During a normal program or erase cycle, the Error flag bit (DQ5) is to '0.' This bit is set to '1' when there is a failure during Flash memory Byte Program, Sector Erase, or Bulk Erase cycle.

In the case of Flash memory programming, the Error flag bit (DQ5) indicates the attempt to program a Flash memory bit from the programmed state, '0,' to the erased state, '1,' which is not valid. The Error flag bit (DQ5) may also indicate a timeout condition while attempting to program a byte.

In case of an error in a Flash memory Sector Erase or Byte Program cycle, the Flash memory sector in which the error occurred or to which the programmed byte belongs must no longer be used. Other Flash memory sectors may still be used. The Error flag bit (DQ5) is reset after a Reset Flash instruction.

7.10 Erase timeout flag (DQ3)

The Erase timeout flag bit (DQ3) reflects the timeout period allowed between two consecutive Sector Erase instructions. The Erase timeout flag bit (DQ3) is reset to '0' after a Sector Erase cycle for a time period of $100\mu\text{s} + 20\%$ unless an additional Sector Erase instruction is decoded. After this time period, or when the additional Sector Erase instruction is decoded, the Erase timeout flag bit (DQ3) is set to '1.'

8 Programming Flash memory

Flash memory must be erased prior to being programmed. A byte of Flash memory is erased to all 1s (FFh), and is programmed by setting selected bits to '0.' The MCU may erase Flash memory all at once or by-sector, but not byte-by-byte. However, the MCU may program Flash memory byte-by-byte.

The primary and secondary Flash memories require the MCU to send an instruction to program a byte or to erase sectors (see [Table 10](#)).

Once the MCU issues a Flash memory Program or Erase instruction, it must check for the status bits for completion. The embedded algorithms that are invoked inside the PSD support several means to provide status to the MCU. Status may be checked using any of three methods: Data Polling, Data Toggle, or Ready/Busy (PC3).

8.1 Data Polling

Polling on the Data Polling flag bit (DQ7) is a method of checking whether a program or erase cycle is in progress or has completed. [Figure 6](#) shows the Data Polling algorithm.

When the MCU issues a Program instruction, the embedded algorithm within the PSD begins. The MCU then reads the location of the byte to be programmed in Flash memory to check status. The Data Polling flag bit (DQ7) of this location becomes the complement of b7 of the original data byte to be programmed. The MCU continues to poll this location, comparing the Data Polling flag bit (DQ7) and monitoring the Error flag bit (DQ5). When the Data Polling flag bit (DQ7) matches b7 of the original data, and the Error flag bit (DQ5) remains '0,' the embedded algorithm is complete. If the Error flag bit (DQ5) is '1,' the MCU should test the Data Polling flag bit (DQ7) again since the Data Polling flag bit (DQ7) may have changed simultaneously with the Error flag bit (DQ5, see [Figure 6](#)).

The Error flag bit (DQ5) is set if either an internal timeout occurred while the embedded algorithm attempted to program the byte or if the MCU attempted to program a '1' to a bit that was not erased (not erased is logic '0').

It is suggested (as with all Flash memories) to read the location again after the embedded programming algorithm has completed, to compare the byte that was written to the Flash memory with the byte that was intended to be written.

When using the Data Polling method during an Erase cycle, [Figure 6](#) still applies. However, the Data Polling flag bit (DQ7) is '0' until the Erase cycle is complete. A 1 on the Error flag bit (DQ5) indicates a timeout condition on the Erase cycle; a 0 indicates no error. The MCU can read any location within the sector being erased to get the Data Polling flag bit (DQ7) and the Error flag bit (DQ5).

PSDsoft Express generates ANSI C code functions which implement these Data Polling algorithms.

Figure 6. Data Polling flowchart

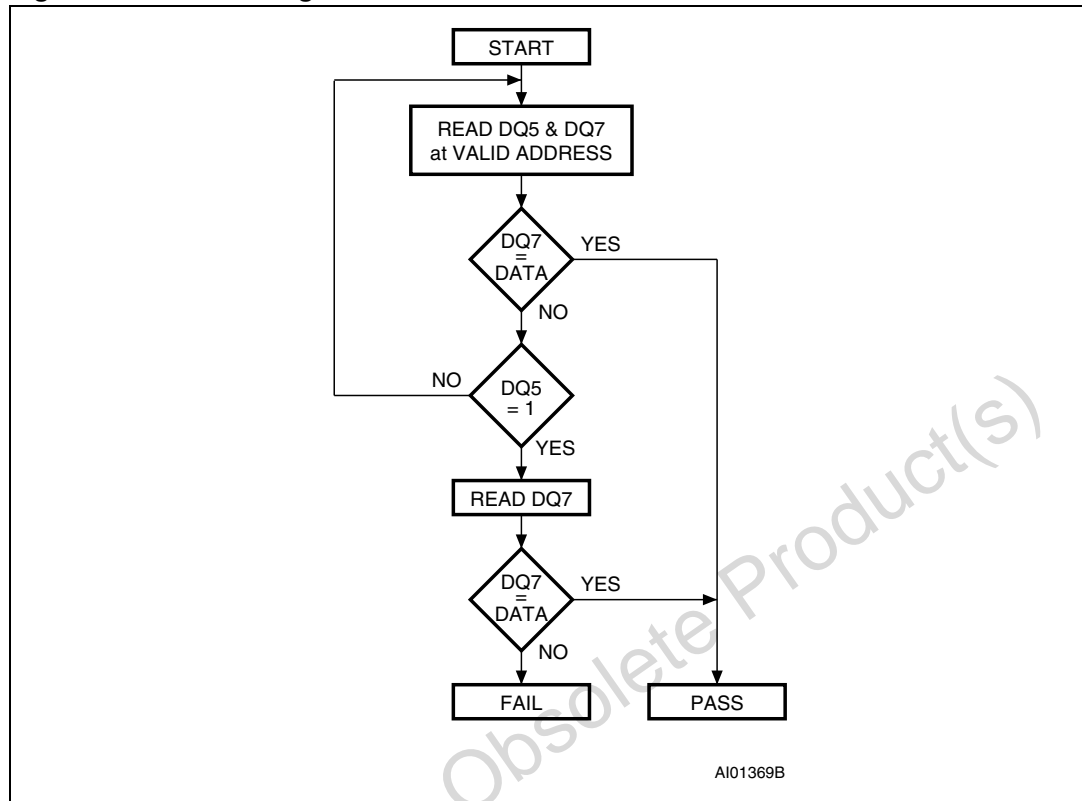

8.2 Data Toggle

Checking the Toggle flag bit (DQ6) is a method of determining whether a program or erase cycle is in progress or has completed. [Figure 7](#) shows the Data Toggle algorithm.

When the MCU issues a Program instruction, the embedded algorithm within the PSD begins. The MCU then reads the location of the byte to be programmed in Flash memory to check status. The Toggle flag bit (DQ6) of this location toggles each time the MCU reads this location until the embedded algorithm is complete. The MCU continues to read this location, checking the Toggle flag bit (DQ6) and monitoring the Error flag bit (DQ5). When the Toggle flag bit (DQ6) stops toggling (two consecutive reads yield the same value), and the Error flag bit (DQ5) remains '0,' the embedded algorithm is complete. If the Error flag bit (DQ5) is '1,' the MCU should test the Toggle flag bit (DQ6) again, since the Toggle flag bit (DQ6) may have changed simultaneously with the Error flag bit (DQ5, see [Figure 7](#)).

The Error flag bit (DQ5) is set if either an internal timeout occurred while the embedded algorithm attempted to program the byte, or if the MCU attempted to program a '1' to a bit that was not erased (not erased is logic '0').

It is suggested (as with all Flash memories) to read the location again after the embedded programming algorithm has completed, to compare the byte that was written to Flash memory with the byte that was intended to be written.

When using the Data Toggle method after an Erase cycle, [Figure 7](#) still applies. the Toggle flag bit (DQ6) toggles until the Erase cycle is complete. A '1' on the Error flag bit (DQ5) indicates a timeout condition on the Erase cycle; a '0' indicates no error. The MCU can read

any location within the sector being erased to get the Toggle flag bit (DQ6) and the Error flag bit (DQ5).

PSDsoft Express generates ANSI C code functions which implement these Data Toggling algorithms.

8.3 **Unlock Bypass (PSD833F2x, PSD834F2x, PSD853F2x, PSD854F2x)**

The Unlock Bypass instructions allow the system to program bytes to the Flash memories faster than using the standard Program instruction. The Unlock Bypass mode is entered by first initiating two Unlock cycles. This is followed by a third WRITE cycle containing the Unlock Bypass code, 20h (as shown in [Table 10](#)).

The Flash memory then enters the Unlock Bypass mode. A two-cycle Unlock Bypass Program instruction is all that is required to program in this mode. The first cycle in this instruction contains the Unlock Bypass Program code, A0h. The second cycle contains the program address and data. Additional data is programmed in the same manner. These instructions dispense with the initial two Unlock cycles required in the standard Program instruction, resulting in faster total Flash memory programming.

During the Unlock Bypass mode, only the Unlock Bypass Program and Unlock Bypass Reset Flash instructions are valid.

To exit the Unlock Bypass mode, the system must issue the two-cycle Unlock Bypass Reset Flash instruction. The first cycle must contain the data 90h; the second cycle the data 00h. Addresses are Don't Care for both cycles. The Flash memory then returns to READ mode.

Figure 7. Data Toggle flowchart

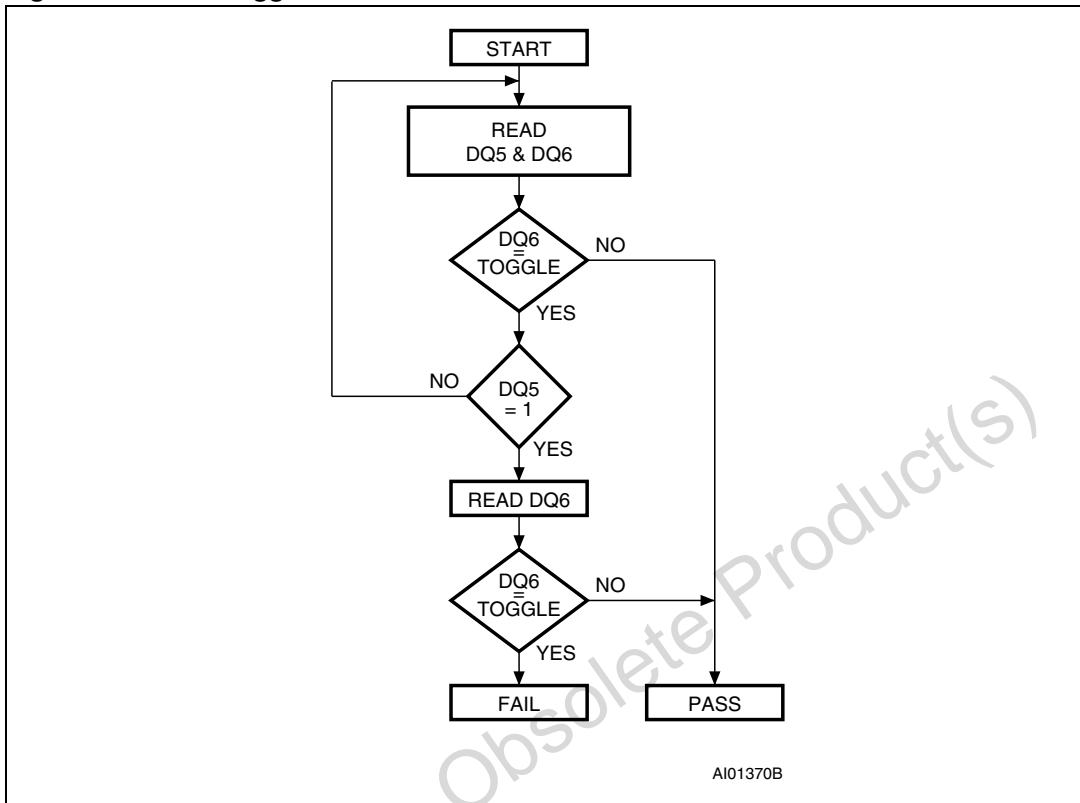

Obsolete Product(s) - Obsolete Product(s)

9 Erasing Flash memory

9.1 Flash Bulk Erase

The Flash Bulk Erase instruction uses six WRITE operations followed by a READ operation of the status register, as described in [Table 10](#). If any byte of the Bulk Erase instruction is wrong, the Bulk Erase instruction aborts and the device is reset to the Read Flash memory status.

During a Bulk Erase, the memory status may be checked by reading the Error flag bit (DQ5), the Toggle flag bit (DQ6), and the Data Polling flag bit (DQ7), as detailed in [Section 8: Programming Flash memory](#). The Error flag bit (DQ5) returns a '1' if there has been an Erase Failure (maximum number of Erase cycles have been executed).

It is not necessary to program the memory with 00h because the PSD automatically does this before erasing to 0FFh.

During execution of the Bulk Erase instruction, the Flash memory does not accept any instructions.

9.2 Flash Sector Erase

The Sector Erase instruction uses six WRITE operations, as described in [Table 10](#). Additional Flash Sector Erase codes and Flash memory sector addresses can be written subsequently to erase other Flash memory sectors in parallel, without further coded cycles, if the additional bytes are transmitted in a shorter time than the timeout period of about 100µs. The input of a new Sector Erase code restarts the timeout period.

The status of the internal timer can be monitored through the level of the Erase timeout flag bit (DQ3). If the Erase timeout flag bit (DQ3) is '0,' the Sector Erase instruction has been received and the timeout period is counting. If the Erase timeout flag bit (DQ3) is '1,' the timeout period has expired and the PSD is busy erasing the Flash memory sector(s). Before and during Erase timeout, any instruction other than Suspend Sector Erase and Resume Sector Erase instructions abort the cycle that is currently in progress, and reset the device to READ mode. It is not necessary to program the Flash memory sector with 00h as the PSD does this automatically before erasing (byte = FFh).

During a Sector Erase, the memory status may be checked by reading the Error flag bit (DQ5), the Toggle flag bit (DQ6), and the Data Polling flag bit (DQ7), as detailed in [Section 8: Programming Flash memory](#).

During execution of the Erase cycle, the Flash memory accepts only Reset and Suspend Sector Erase instructions. Erasure of one Flash memory sector may be suspended, in order to read data from another Flash memory sector, and then resumed.

9.3 Suspend Sector Erase

When a Sector Erase cycle is in progress, the Suspend Sector Erase instruction can be used to suspend the cycle by writing 0B0h to any address when an appropriate Sector Select (FS0-FS7 or CSBOOT0-CSBOOT3) is high. (See [Table 10](#)). This allows reading of data from another Flash memory sector after the Erase cycle has been suspended. Suspend Sector Erase is accepted only during an Erase cycle and defaults to READ mode.

A Suspend Sector Erase instruction executed during an Erase timeout period, in addition to suspending the Erase cycle, terminates the time out period.

The Toggle flag bit (DQ6) stops toggling when the PSD internal logic is suspended. The status of this bit must be monitored at an address within the Flash memory sector being erased. The Toggle flag bit (DQ6) stops toggling between 0.1 μ s and 15 μ s after the Suspend Sector Erase instruction has been executed. The PSD is then automatically set to READ mode.

If an Suspend Sector Erase instruction was executed, the following rules apply:

- Attempting to read from a Flash memory sector that was being erased outputs invalid data.
- Reading from a Flash sector that was *not* being erased is valid.
- The Flash memory cannot be programmed, and only responds to Resume Sector Erase and Reset Flash instructions (READ is an operation and is allowed).
- If a Reset Flash instruction is received, data in the Flash memory sector that was being erased is invalid.

9.4 Resume Sector Erase

If a Suspend Sector Erase instruction was previously executed, the erase cycle may be resumed with this instruction. The Resume Sector Erase instruction consists of writing 030h to any address while an appropriate Sector Select (FS0-FS7 or CSBOOT0-CSBOOT3) is high. (See [Table 10](#).)

10 Specific features

10.1 Flash Memory Sector Protect

Each primary and secondary Flash memory sector can be separately protected against Program and Erase cycles. Sector Protection provides additional data security because it disables all program or erase cycles. This mode can be activated through the JTAG port or a device programmer.

Sector protection can be selected for each sector using the PSDsoft Express Configuration program. This automatically protects selected sectors when the device is programmed through the JTAG port or a device programmer. Flash memory sectors can be unprotected to allow updating of their contents using the JTAG port or a device programmer. The MCU can read (but cannot change) the sector protection bits.

Any attempt to program or erase a protected Flash memory sector is ignored by the device. The Verify operation results in a READ of the protected data. This allows a guarantee of the retention of the Protection status.

The sector protection status can be read by the MCU through the Flash memory protection and PSD/EE protection registers (in the CSIOP block). See [Table 12](#) and [Table 13](#).

10.2 Reset Flash

The Reset Flash instruction consists of one WRITE cycle (see [Table 10](#)). It can also be optionally preceded by the standard two WRITE decoding cycles (writing AAh to 555h and 55h to AAAh). It must be executed after:

- Reading the Flash Protection Status or Flash ID
- An Error condition has occurred (and the device has set the Error flag bit (DQ5) to '1') during a Flash memory program or erase cycle.

On the PSD813F2/3/4/5, the Reset Flash instruction puts the Flash memory back into normal READ mode. It may take the Flash memory up to a few milliseconds to complete the Reset cycle. The Reset Flash instruction is ignored when it is issued during a Program or Bulk Erase cycle of the Flash memory. The Reset Flash instruction aborts any on-going Sector Erase cycle, and returns the Flash memory to the normal READ mode within a few milliseconds.

On the PSD83xF2 or PSD85xF2, the Reset Flash instruction puts the Flash memory back into normal READ mode. If an Error condition has occurred (and the device has set the Error flag bit (DQ5) to '1') the Flash memory is put back into normal READ mode within 25µs of the Reset Flash instruction having been issued. The Reset Flash instruction is ignored when it is issued during a Program or Bulk Erase cycle of the Flash memory. The Reset Flash instruction aborts any on-going Sector Erase cycle, and returns the Flash memory to the normal READ mode within 25µs.

10.3 Reset ($\overline{\text{RESET}}$) signal (on the PSD83xF2 and PSD85xF2)

A pulse on Reset ($\overline{\text{RESET}}$) aborts any cycle that is in progress, and resets the Flash memory to the READ mode. When the reset occurs during a program or erase cycle, the Flash memory takes up to 25 μs to return to the READ mode. It is recommended that the Reset ($\overline{\text{RESET}}$) pulse (except for Power On Reset, as described in [Section 18: Reset timing and device status at reset](#)) be at least 25 μs so that the Flash memory is always ready for the MCU to fetch the bootstrap instructions after the Reset cycle is complete.

Table 12. Sector Protection/Security Bit definition – Flash Protection register⁽¹⁾

Bit 7	Bit 6	Bit 5	Bit 4	Bit 3	Bit 2	Bit 1	Bit 0
Sec7_Prot	Sec6_Prot	Sec5_Prot	Sec4_Prot	Sec3_Prot	Sec2_Prot	Sec1_Prot	Sec0_Prot

1. Bit Definitions:
 Sec<i>_Prot 1 = Primary Flash memory or secondary Flash memory Sector <i> is write protected.
 Sec<i>_Prot 0 = Primary Flash memory or secondary Flash memory Sector <i> is not write protected.

Table 13. Sector Protection/Security Bit definition – PSD/EE Protection register⁽¹⁾

Bit 7	Bit 6	Bit 5	Bit 4	Bit 3	Bit 2	Bit 1	Bit 0
Security_Bit	not used	not used	not used	Sec3_Prot	Sec2_Prot	Sec1_Prot	Sec0_Prot

1. Bit Definitions:
 Sec<i>_Prot 1 = Secondary Flash memory Sector <i> is write protected.
 Sec<i>_Prot 0 = Secondary Flash memory Sector <i> is not write protected.
 Security_Bit 0 = Security Bit in device has not been set.
 1 = Security Bit in device has been set.

11 SRAM

The SRAM is enabled when SRAM Select (RS0) from the DPLD is high. SRAM Select (RS0) can contain up to two product terms, allowing flexible memory mapping.

SRAM Select (RS0) is configured using PSDsoft Express Configuration.

Obsolete Product(s) - Obsolete Product(s)

12 Sector Select and SRAM Select

Sector Select (FS0-FS7, CSBOOT0-CSBOOT3) and SRAM Select (RS0) are all outputs of the DPLD. They are setup by writing equations for them in PSDLabel. The following rules apply to the equations for these signals:

1. Primary Flash memory and secondary Flash memory Sector Select signals must *not* be larger than the physical sector size.
2. Any primary Flash memory sector must *not* be mapped in the same memory space as another Flash memory sector.
3. A secondary Flash memory sector must *not* be mapped in the same memory space as another secondary Flash memory sector.
4. SRAM, I/O, and Peripheral I/O spaces must *not* overlap.
5. A secondary Flash memory sector *may* overlap a primary Flash memory sector. In case of overlap, priority is given to the secondary Flash memory sector.
6. SRAM, I/O, and Peripheral I/O spaces *may* overlap any other memory sector. Priority is given to the SRAM, I/O, or Peripheral I/O.

12.1 Example

FS0 is valid when the address is in the range of 8000h to BFFFh, CSBOOT0 is valid from 8000h to 9FFFh, and RS0 is valid from 8000h to 87FFh. Any address in the range of RS0 always accesses the SRAM. Any address in the range of CSBOOT0 greater than 87FFh (and less than 9FFFh) automatically addresses secondary Flash memory segment 0. Any address greater than 9FFFh accesses the primary Flash memory segment 0. You can see that half of the primary Flash memory segment 0 and one-fourth of secondary Flash memory segment 0 cannot be accessed in this example. Also note that an equation that defined FS1 to anywhere in the range of 8000h to BFFFh would *not* be valid.

Figure 8 shows the priority levels for all memory components. Any component on a higher level can overlap and has priority over any component on a lower level. Components on the same level must *not* overlap. Level one has the highest priority and level 3 has the lowest.

12.2 Memory select configuration for MCUs with separate program and data spaces

The 8031 and compatible family of MCUs, which includes the 80C51, 80C151, 80C251, and 80C51XA, have separate address spaces for program memory (selected using Program Select Enable (PSEN, CNTL2)) and data memory (selected using Read Strobe (RD, CNTL1)). Any of the memories within the PSD can reside in either space or both spaces.

This is controlled through manipulation of the VM register that resides in the CSIOP space.

The VM register is set using PSDsoft Express to have an initial value. It can subsequently be changed by the MCU so that memory mapping can be changed on-the-fly.

For example, you may wish to have SRAM and primary Flash memory in the data space at Boot-up, and secondary Flash memory in the program space at Boot-up, and later swap the primary and secondary Flash memories. This is easily done with the VM register by using

PSDsoft Express Configuration to configure it for Boot-up and having the MCU change it when desired. [Table 14](#) describes the VM register.

Figure 8. Priority level of memory and I/O components

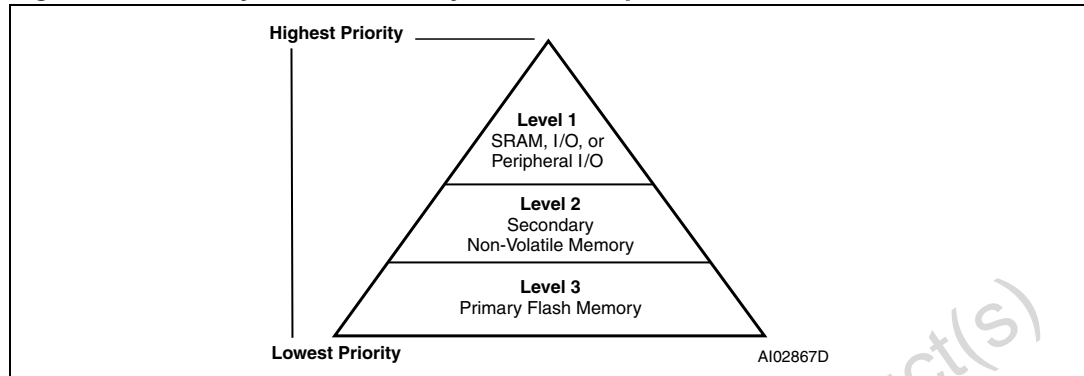

12.3 Configuration modes for MCUs with separate program and data spaces

12.3.1 Separate Space modes

Program space is separated from data space. For example, Program Select Enable ($\overline{\text{PSEN}}$, CNTL2) is used to access the program code from the primary Flash memory, while Read Strobe ($\overline{\text{RD}}$, CNTL1) is used to access data from the secondary Flash memory, SRAM and I/O port blocks. This configuration requires the VM register to be set to 0Ch (see [Figure 9](#)).

12.3.2 Combined Space modes

The program and data spaces are combined into one memory space that allows the primary Flash memory, secondary Flash memory, and SRAM to be accessed by either Program Select Enable ($\overline{\text{PSEN}}$, CNTL2) or Read Strobe ($\overline{\text{RD}}$, CNTL1). For example, to configure the primary Flash memory in Combined space, Bits b2 and b4 of the VM register are set to '1' (see [Figure 10](#)).

Figure 9. 8031 memory modules – separate space

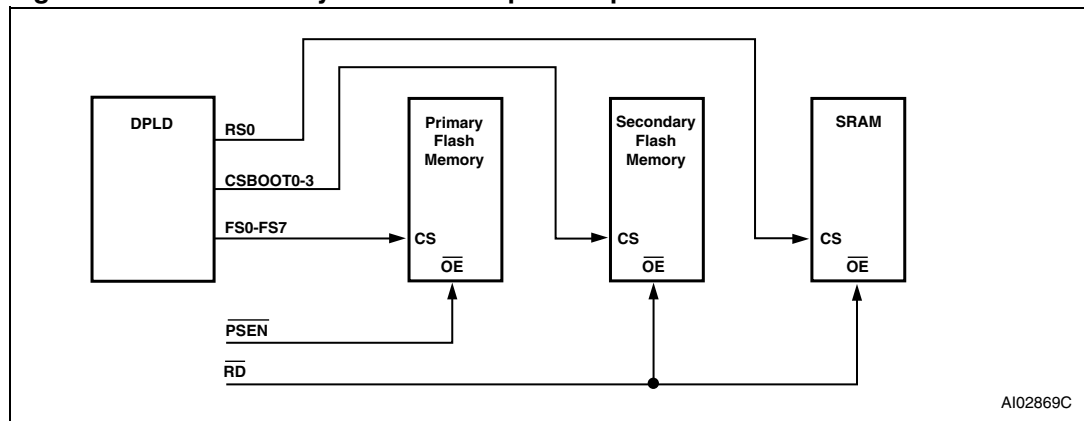

Figure 10. 8031 memory modules – combined space

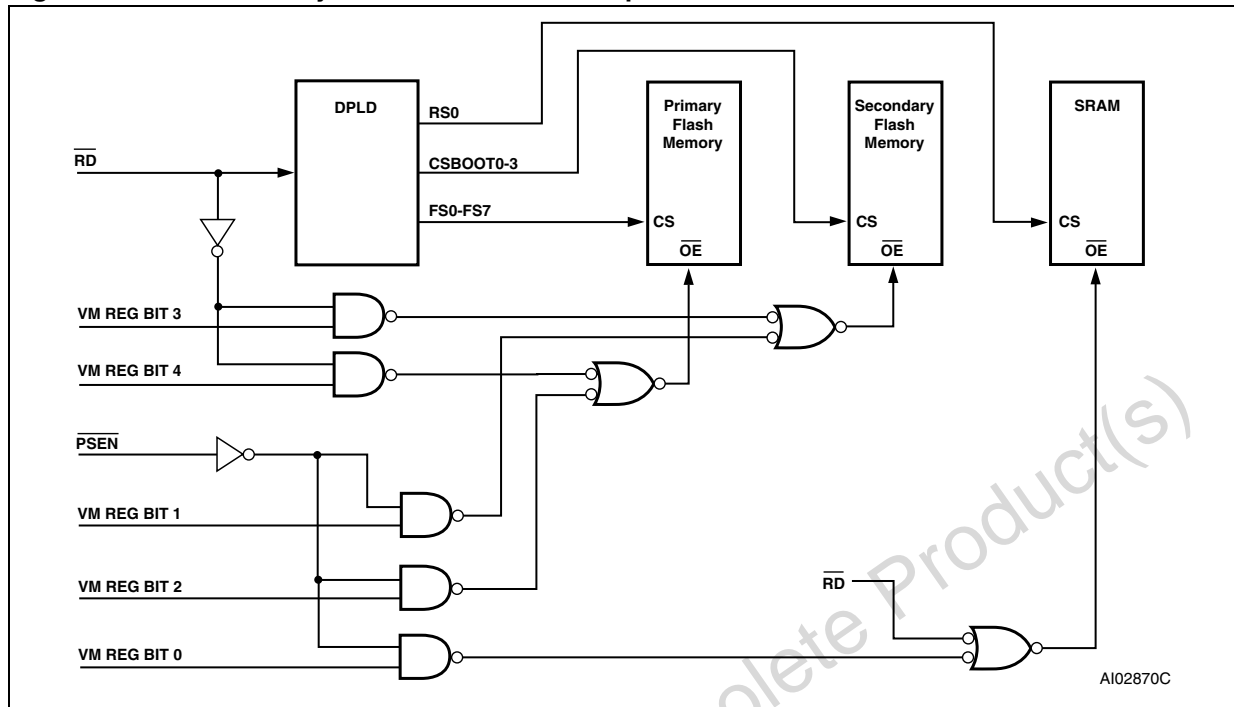

Table 14. VM register

Bit 7 PIO_EN	Bit 6	Bit 5	Bit 4 Primary FL_Data	Bit 3 econdary EE_Data	Bit 2 Primary FL_Code	Bit 1 Secondary EE_Code	Bit 0 SRAM_Code
0 = disable PIO mode	not used	not used	0 = \overline{RD} cannot access Flash memory	0 = \overline{RD} can't access secondary Flash memory	0 = \overline{PSEN} cannot access Flash memory	0 = \overline{PSEN} can't access secondary Flash memory	0 = \overline{PSEN} cannot access SRAM
1 = enable PIO mode	not used	not used	1 = \overline{RD} access Flash memory	1 = \overline{RD} access secondary Flash memory	1 = \overline{PSEN} access Flash memory	1 = \overline{PSEN} access secondary Flash memory	1 = \overline{PSEN} access SRAM

13 Page register

The 8-bit Page register increases the addressing capability of the MCU by a factor of up to 256. The contents of the register can also be read by the MCU. The outputs of the Page register (PGR0-PGR7) are inputs to the DPLD decoder and can be included in the Sector Select (FS0-FS7, CSBOOT0-CSBOOT3), and SRAM Select (RS0) equations.

If memory paging is not needed, or if not all 8 page register bits are needed for memory paging, then these bits may be used in the CPLD for general logic. See Application Note AN1154.

Figure 11 shows the Page register. The eight flip-flops in the register are connected to the internal data bus D0-D7. The MCU can write to or read from the Page register. The Page register can be accessed at address location CSIOP + E0h.

Figure 11. Page register

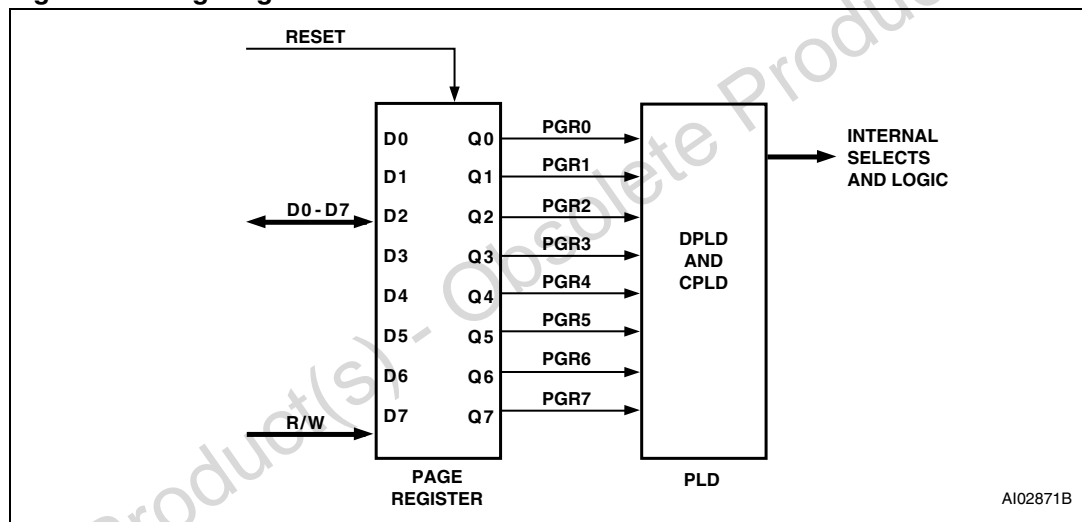

14 PLDS

The PLDs bring programmable logic functionality to the PSD. After specifying the logic for the PLDs using the PSDabel tool in PSDsoft Express, the logic is programmed into the device and available upon Power-up.

The PSD contains two PLDs: the Decode PLD (DPLD), and the Complex PLD (CPLD). The PLDs are briefly discussed in the next few paragraphs, and in more detail in [Section 14.2: Decode PLD \(DPLD\)](#), and [Section 14.3: Complex PLD \(CPLD\)](#). [Figure 12](#) shows the configuration of the PLDs.

The DPLD performs address decoding for Select signals for internal components, such as memory, registers, and I/O ports.

The CPLD can be used for logic functions, such as loadable counters and shift registers, state machines, and encoding and decoding logic. These logic functions can be constructed using the 16 Output macrocells (OMC), 24 input macrocells (IMC), and the AND Array. The CPLD can also be used to generate External Chip Select (ECS0-ECS2) signals.

The AND Array is used to form product terms. These product terms are specified using PSDabel. An input bus consisting of 73 signals is connected to the PLDs. The signals are shown in [Table 15](#).

14.1 The Turbo Bit in PSD

The PLDs in the PSD can minimize power consumption by switching off when inputs remain unchanged for an extended time of about 70ns. Resetting the Turbo Bit to '0' (Bit 3 of PMMR0) automatically places the PLDs into standby if no inputs are changing. Turning the Turbo mode off increases propagation delays while reducing power consumption. See [Section 17: Power management](#) on how to set the Turbo Bit.

Additionally, five bits are available in PMMR2 to block MCU control signals from entering the PLDs. This reduces power consumption and can be used only when these MCU control signals are not used in PLD logic equations.

Each of the two PLDs has unique characteristics suited for its applications. They are described in the following sections.

Table 15. DPLD and CPLD inputs

Input source	Input name	Number of signals
MCU address bus ⁽¹⁾	A15-A0	16
MCU control signals	CNTL2-CNTL0	3
Reset	$\overline{\text{RST}}$	1
Power-down	PDN	1
Port A input macrocells	PA7-PA0	8
Port B input macrocells	PB7-PB0	8
Port C input macrocells	PC7-PC0	8
Port D inputs	PD2-PD0	3

Table 15. DPLD and CPLD inputs (continued)

Input source	Input name	Number of signals
Page register	PGR7-PGR0	8
Macrocell AB feedback	MCELLAB.FB7-FB0	8
Macrocell BC feedback	MCELLBC.FB7-FB0	8
Secondary Flash memory Program Status Bit	Ready/ $\overline{\text{Busy}}$	1

1. The address inputs are A19-A4 in 80C51XA mode.

Obsolete Product(s) - Obsolete Product(s)

Figure 12. PLD diagram

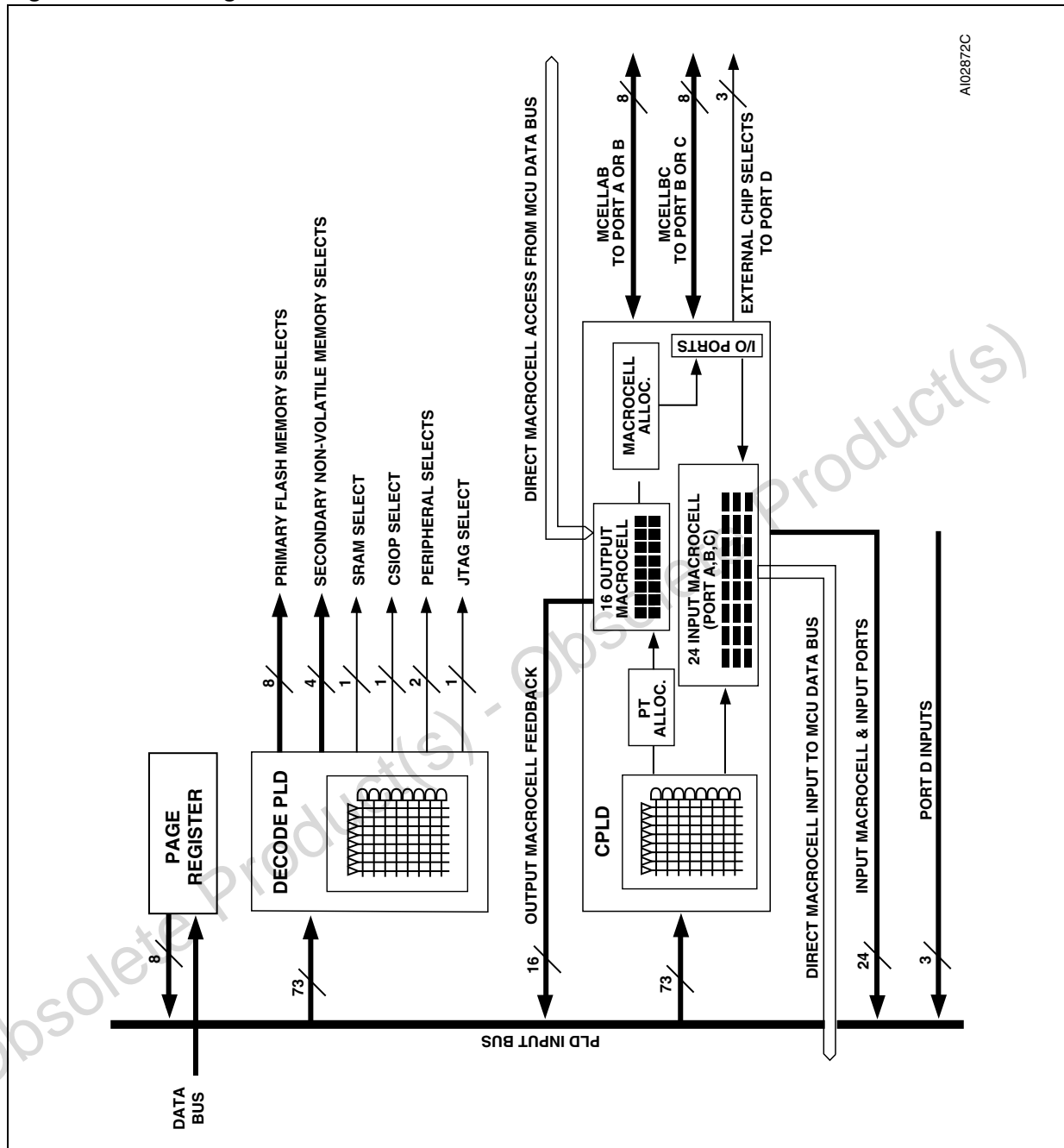

14.2 Decode PLD (DPLD)

The DPLD, shown in *Figure 13*, is used for decoding the address for internal and external components. The DPLD can be used to generate the following decode signals:

- 8 Sector Select (FS0-FS7) signals for the primary Flash memory (three product terms each)
- 4 Sector Select (CSBOOT0-CSBOOT3) signals for the secondary Flash memory (three product terms each)
- 1 internal SRAM Select (RS0) signal (two product terms)
- 1 internal CSIOP Select (PSD Configuration register) signal
- 1 JTAG Select signal (enables JTAG on port C)
- 2 internal Peripheral Select signals (Peripheral I/O mode).

Figure 13. DPLD logic array

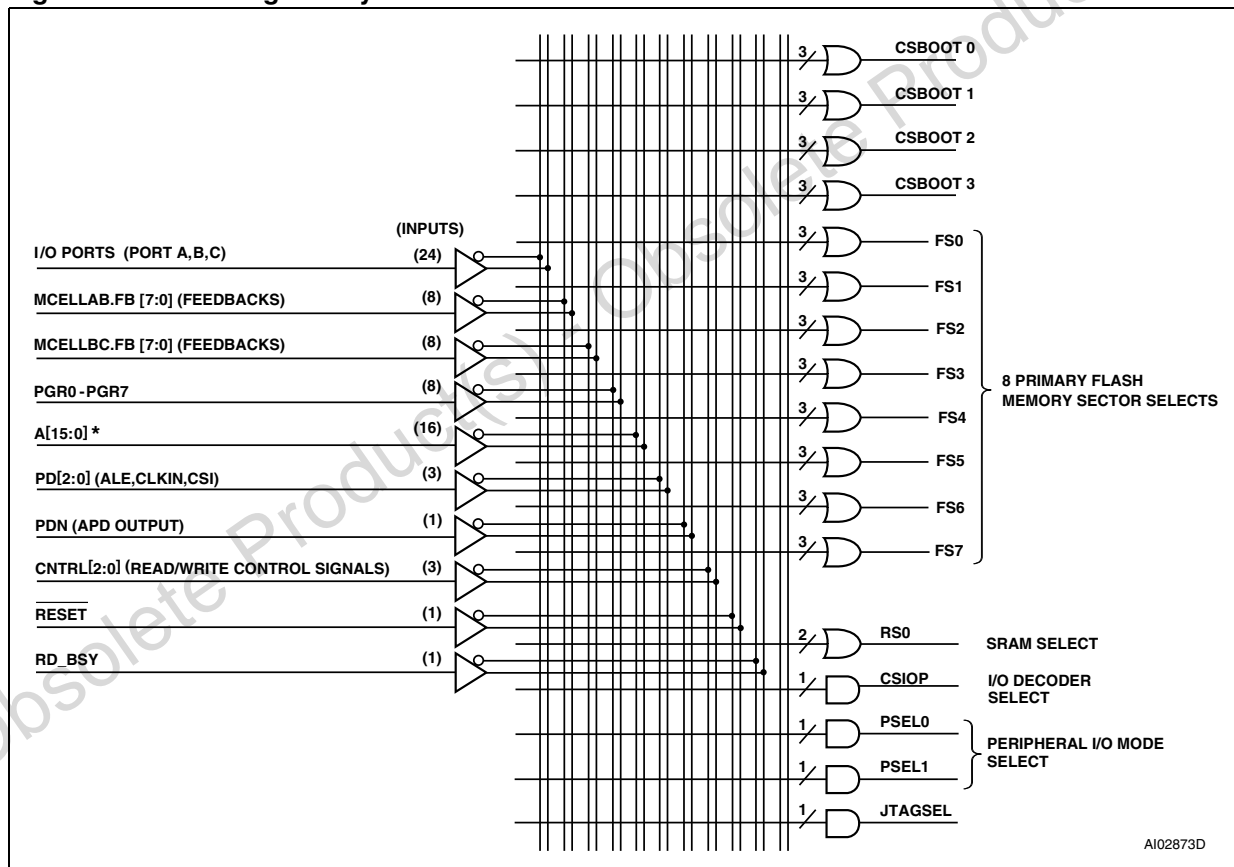

AI02873D

14.3 Complex PLD (CPLD)

The CPLD can be used to implement system logic functions, such as loadable counters and shift registers, system mailboxes, handshaking protocols, state machines, and random logic. The CPLD can also be used to generate three External Chip Select (ECS0-ECS2), routed to port D.

Although External Chip Select (ECS0-ECS2) can be produced by any Output macrocell (OMC), these three External Chip Select (ECS0-ECS2) on port D do not consume any Output macrocells (OMC).

As shown in [Figure 12](#), the CPLD has the following blocks:

- 24 input macrocells (IMC)
- 16 Output macrocells (OMC)
- Macrocell Allocator
- Product Term Allocator
- AND Array capable of generating up to 137 product terms
- Four I/O ports.

Each of the blocks are described in the sections that follow.

The input macrocells (IMC) and Output macrocells (OMC) are connected to the PSD internal data bus and can be directly accessed by the MCU. This enables the MCU software to load data into the Output macrocells (OMC) or read data from both the input and Output macrocells (IMC and OMC).

This feature allows efficient implementation of system logic and eliminates the need to connect the data bus to the AND Array as required in most standard PLD macrocell architectures.

Figure 14. Macrocell and I/O port

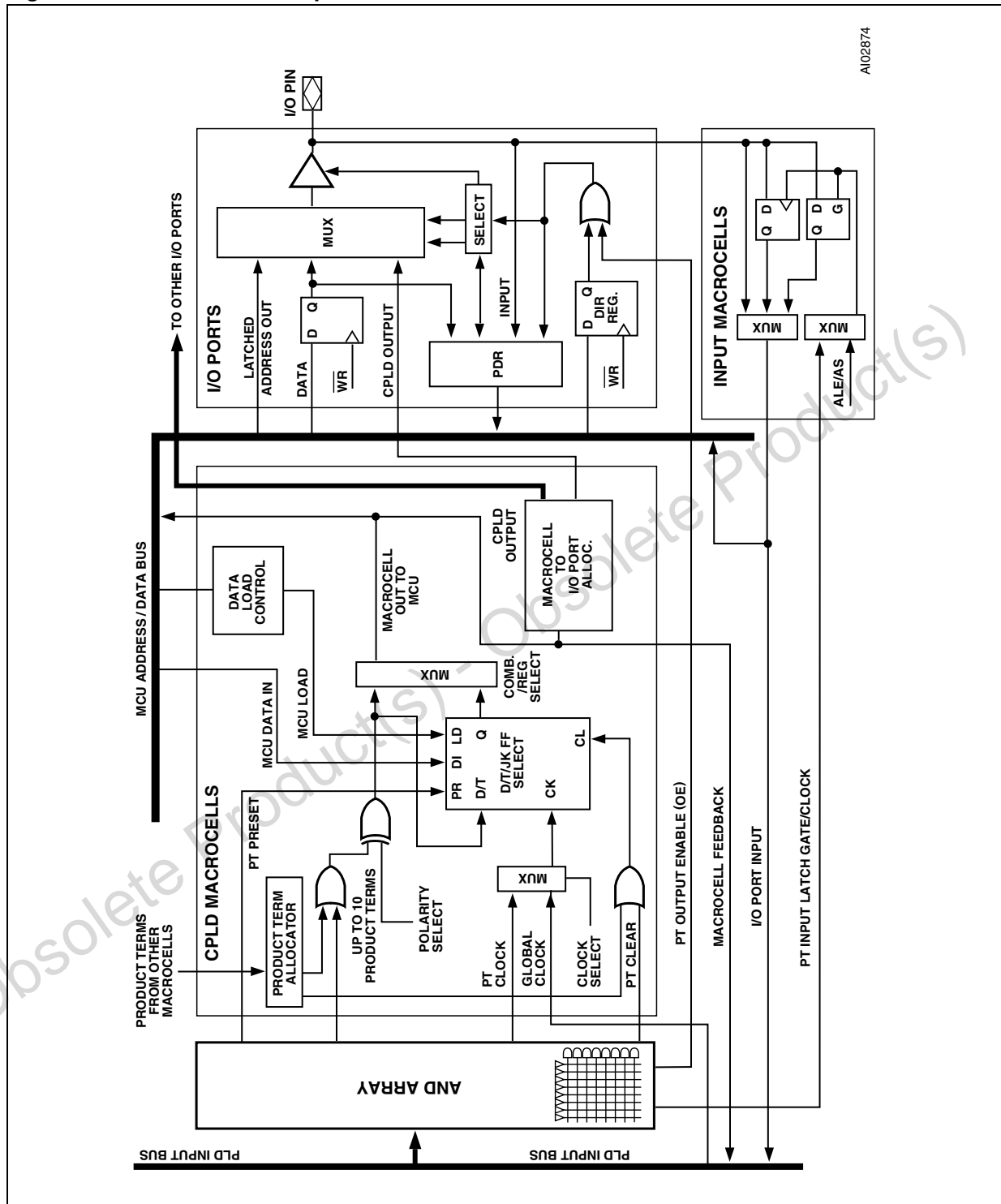

14.4 Output macrocell (OMC)

Eight of the Output macrocells (OMC) are connected to ports A and B pins and are named as McellAB0-McellAB7. The other eight macrocells are connected to ports B and C pins and are named as McellBC0-McellBC7. If an McellAB output is not assigned to a specific pin in PSDabel, the macrocell Allocator block assigns it to either port A or B. The same is true for a McellBC output on port B or C. [Table 16](#) shows the macrocells and port assignment.

The Output macrocell (OMC) architecture is shown in [Figure 15](#). As shown in the figure, there are native product terms available from the AND Array, and borrowed product terms available (if unused) from other Output macrocells (OMC). The polarity of the product term is controlled by the XOR gate. The Output macrocell (OMC) can implement either sequential logic, using the flip-flop element, or combinatorial logic. The multiplexer selects between the sequential or combinatorial logic outputs. The multiplexer output can drive a port pin and has a feedback path to the AND Array inputs.

The flip-flop in the Output macrocell (OMC) block can be configured as a D, T, JK, or SR type in the PSDabel program. The flip-flop's clock, preset, and clear inputs may be driven from a product term of the AND Array. Alternatively, CLKIN (PD1) can be used for the clock input to the flip-flop. The flip-flop is clocked on the rising edge of CLKIN (PD1). The preset and clear are active high inputs. Each clear input can use up to two product terms.

Table 16. Output macrocell port and data bit assignments

Output macrocell	Port assignment	Native product terms	Maximum borrowed product terms	Data bit for loading or reading
McellAB0	Port A0, B0	3	6	D0
McellAB1	Port A1, B1	3	6	D1
McellAB2	Port A2, B2	3	6	D2
McellAB3	Port A3, B3	3	6	D3
McellAB4	Port A4, B4	3	6	D4
McellAB5	Port A5, B5	3	6	D5
McellAB6	Port A6, B6	3	6	D6
McellAB7	Port A7, B7	3	6	D7
McellBC0	Port B0, C0	4	5	D0
McellBC1	Port B1, C1	4	5	D1
McellBC2	Port B2, C2	4	5	D2
McellBC3	Port B3, C3	4	5	D3
McellBC4	Port B4, C4	4	6	D4
McellBC5	Port B5, C5	4	6	D5
McellBC6	Port B6, C6	4	6	D6
McellBC7	Port B7, C7	4	6	D7

14.5 Product Term Allocator

The CPLD has a Product Term Allocator. The PSDLabel compiler uses the Product Term Allocator to borrow and place product terms from one macrocell to another. The following list summarizes how product terms are allocated:

- McellAB0-McellAB7 all have three native product terms and may borrow up to six more
- McellBC0-McellBC3 all have four native product terms and may borrow up to five more
- McellBC4-McellBC7 all have four native product terms and may borrow up to six more.

Each macrocell may only borrow product terms from certain other macrocells. Product terms already in use by one macrocell are not available for another macrocell.

If an equation requires more product terms than are available to it, then “external” product terms are required, which consume other Output macrocells (OMC). If external product terms are used, extra delay is added for the equation that required the extra product terms.

This is called product term expansion. PSDsoft Express performs this expansion as needed.

14.6 Loading and reading the Output macrocells (OMC)

The Output macrocells (OMC) block occupies a memory location in the MCU address space, as defined by the CSIOP block (see [Section 16: I/O ports](#)). The flip-flops in each of the 16 Output macrocells (OMC) can be loaded from the data bus by a MCU. Loading the Output macrocells (OMC) with data from the MCU takes priority over internal functions. As such, the preset, clear, and clock inputs to the flip-flop can be overridden by the MCU. The ability to load the flip-flops and read them back is useful in such applications as loadable counters and shift registers, mailboxes, and handshaking protocols.

Data can be loaded to the Output macrocells (OMC) on the trailing edge of Write Strobe (\overline{WR} , CNTL0) (edge loading) or during the time that Write Strobe (\overline{WR} , CNTL0) is active (level loading). The method of loading is specified in PSDsoft Express Configuration.

14.7 The OMC Mask register

There is one Mask register for each of the two groups of eight Output macrocells (OMC). The Mask registers can be used to block the loading of data to individual Output macrocells (OMC). The default value for the Mask registers is 00h, which allows loading of the Output macrocells (OMC). When a given bit in a Mask register is set to a 1, the MCU is blocked from writing to the associated Output macrocells (OMC). For example, suppose McellAB0-McellAB3 are being used for a state machine. You would not want a MCU write to McellAB to overwrite the state machine registers. Therefore, you would want to load the Mask register for McellAB (Mask macrocell AB) with the value 0Fh.

14.8 The Output Enable of the OMC

The Output macrocells (OMC) block can be connected to an I/O port pin as a PLD output. The output enable of each port pin driver is controlled by a single product term from the AND Array, ORed with the Direction register output. The pin is enabled upon Power-up if no output enable equation is defined and if the pin is declared as a PLD output in PSDsoft Express.

If the Output macrocell (OMC) output is declared as an internal node and not as a port pin output in the PSDabel file, the port pin can be used for other I/O functions. The internal node feedback can be routed as an input to the AND Array.

Figure 15. CPLD Output macrocell

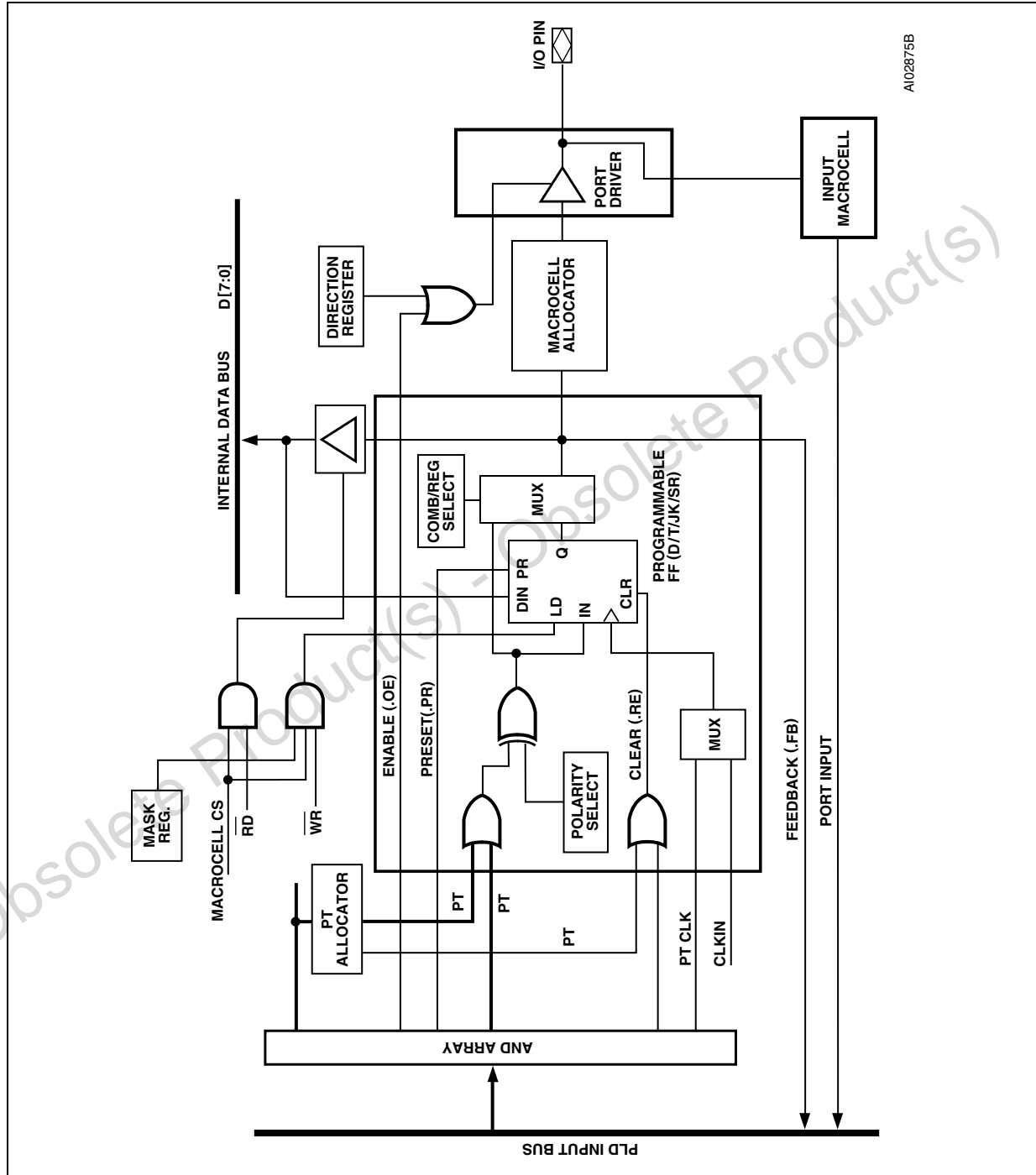

14.9 Input macrocells (IMC)

The CPLD has 24 input macrocells (IMC), one for each pin on ports A, B, and C. The architecture of the input macrocells (IMC) is shown in [Figure 16](#). The input macrocells (IMC) are individually configurable, and can be used as a latch, register, or to pass incoming port signals prior to driving them onto the PLD input bus. The outputs of the input macrocells (IMC) can be read by the MCU through the internal data bus.

The enable for the latch and clock for the register are driven by a multiplexer whose inputs are a product term from the CPLD AND Array or the MCU Address Strobe (ALE/AS). Each product term output is used to latch or clock four input macrocells (IMC). port inputs 3-0 can be controlled by one product term and 7-4 by another.

Configurations for the input macrocells (IMC) are specified by equations written in PSDabel (see Application Note [AN1171](#)). outputs of the input macrocells (IMC) can be read by the MCU via the IMC buffer (see [Section 16: I/O ports](#)).

Input macrocells (IMC) can use Address Strobe (ALE/AS, PD0) to latch address bits higher than A15. Any latched addresses are routed to the PLDs as inputs.

Input macrocells (IMC) are particularly useful with handshaking communication applications where two processors pass data back and forth through a common mailbox. [Figure 17](#) shows a typical configuration where the Master MCU writes to the port A Data Out register. This, in turn, can be read by the Slave MCU via the activation of the "Slave-Read" output enable product term.

The Slave can also write to the port A input macrocells (IMC) and the Master can then read the input macrocells (IMC) directly.

Note that the "Slave-Read" and "Slave-Wr" signals are product terms that are derived from the Slave MCU inputs Read Strobe (\overline{RD} , CNTL1), Write Strobe (\overline{WR} , CNTL0), and Slave_CS.

Figure 16. Input macrocell

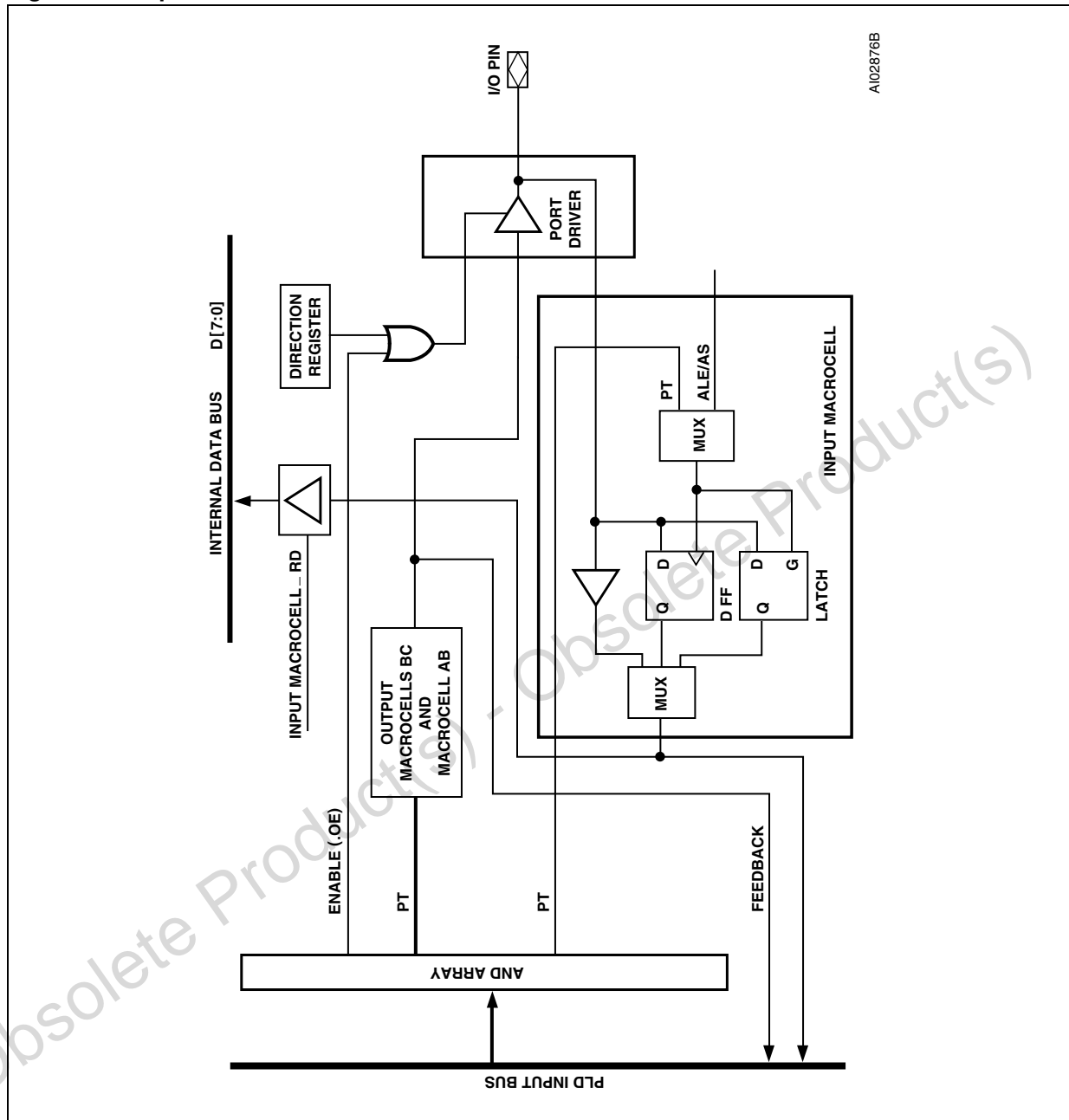
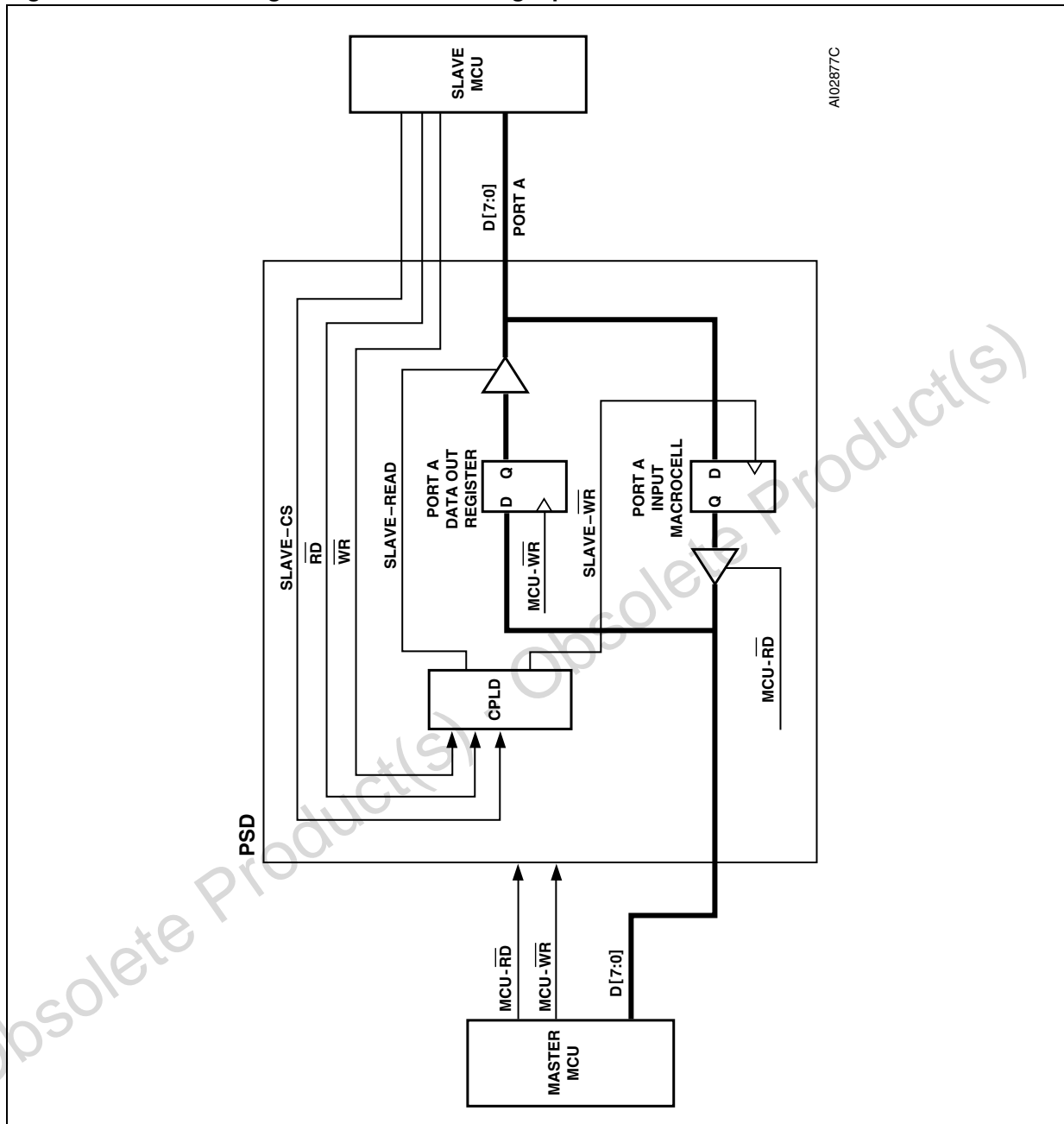

Figure 17. Handshaking communication using input macrocells



15 MCU bus interface

The “no-glue logic” MCU bus interface block can be directly connected to most popular MCUs and their control signals. Key 8-bit MCUs, with their bus types and control signals, are shown in [Table 17](#). The interface type is specified using the PSDsoft Express Configuration.

Table 17. MCUs and their control signals

MCU	Data bus width	CNTL0	CNTL1	CNTL2	PC7	PD0 ⁽¹⁾	ADIO0	PA3-PA0	PA7-PA3
8031	8	\overline{WR}	RD	PSEN	(2)	ALE	A0	(2)	(2)
80C51XA	8	\overline{WR}	RD	PSEN	(2)	ALE	A4	A3-A0	(2)
80C251	8	\overline{WR}	PSEN	(2)	(2)	ALE	A0	(2)	(2)
80C251	8	\overline{WR}	RD	PSEN	(2)	ALE	A0	(2)	(2)
80198	8	\overline{WR}	RD	(2)	(2)	ALE	A0	(2)	(2)
68HC11	8	R/ \overline{W}	E	(2)	(2)	AS	A0	(2)	(2)
68HC912	8	R/ \overline{W}	E	(2)	DBE	AS	A0	(2)	(2)
Z80	8	\overline{WR}	\overline{RD}	(2)	(2)	(2)	A0	D3-D0	D7-D4
Z8	8	R/ \overline{W}	DS	(2)	(2)	AS	A0	(2)	(2)
68330	8	R/ \overline{W}	DS	(2)	(2)	AS	A0	(2)	(2)
M37702M2	8	R/ \overline{W}	E	(2)	(2)	ALE	A0	D3-D0	D7-D4

1. ALE/AS input is optional for MCUs with a non-multiplexed bus
2. Unused CNTL2 pin can be configured as CPLD input. Other unused pins (PC7, PD0, PA3-0) can be configured for other I/O functions.

15.1 PSD interface to a multiplexed 8-bit bus

Figure 18 shows an example of a system using a MCU with an 8-bit multiplexed bus and a PSD. The ADIO port on the PSD is connected directly to the MCU address/data bus. Address Strobe (ALE/AS, PD0) latches the address signals internally. Latched addresses can be brought out to port A or B. The PSD drives the ADIO data bus only when one of its internal resources is accessed and Read Strobe (RD, CNTRL1) is active. Should the system address bus exceed sixteen bits, ports A, B, C, or D may be used as additional address inputs.

Figure 18. An example of a typical 8-bit multiplexed bus interface

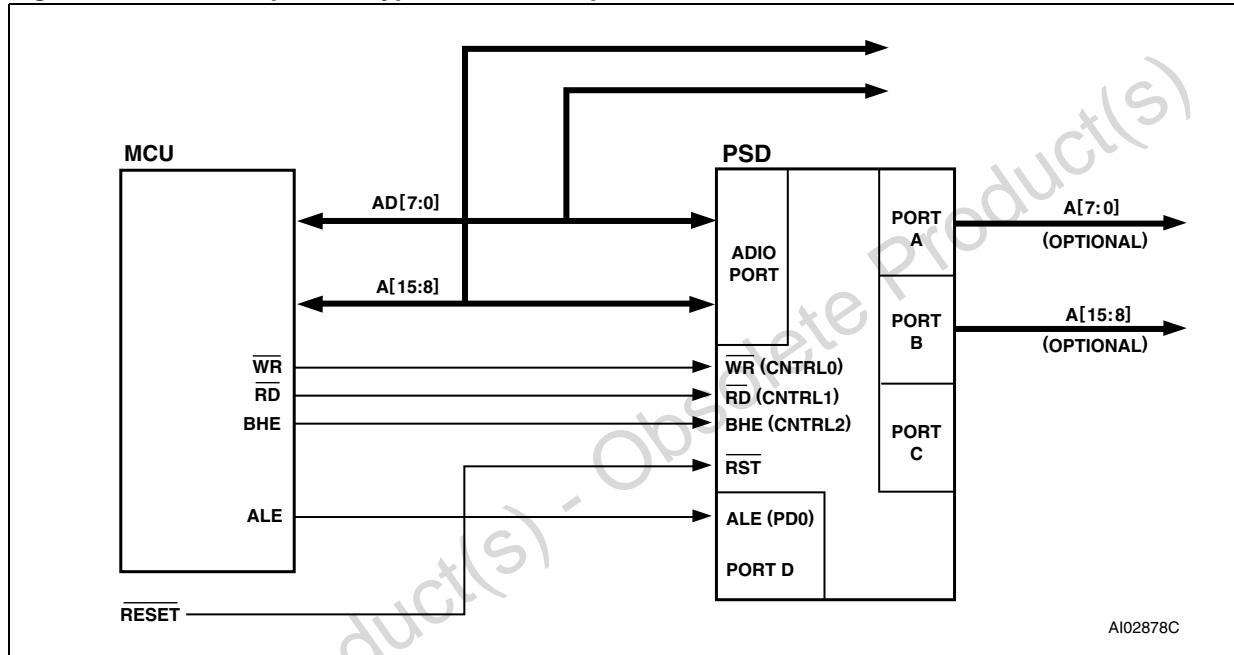

15.2 PSD interface to a non-multiplexed 8-bit bus

Figure 19 shows an example of a system using a MCU with an 8-bit non-multiplexed bus and a PSD. The address bus is connected to the ADIO port, and the data bus is connected to port A. port A is in tri-state mode when the PSD is not accessed by the MCU. Should the system address bus exceed sixteen bits, ports B, C, or D may be used for additional address inputs.

15.3 Data Byte Enable reference

MCUs have different data byte orientations. Table 18 shows how the PSD interprets byte/word operations in different bus WRITE configurations. Even-byte refers to locations with address A0 equal to '0' and odd byte as locations with A0 equal to '1.'

15.4 MCU bus interface examples

Figure 20, Figure 21, Figure 22, Figure 23, and Figure 24 show examples of the basic connections between the PSD and some popular MCUs. The PSD Control input pins are labeled as to the MCU function for which they are configured. The MCU bus interface is specified using the PSDsoft Express Configuration.

Table 18. 8-bit data bus

BHE	A0	D7-D0
X	0	Even byte
X	1	Odd byte

Figure 19. An example of a typical 8-bit non-multiplexed bus interface

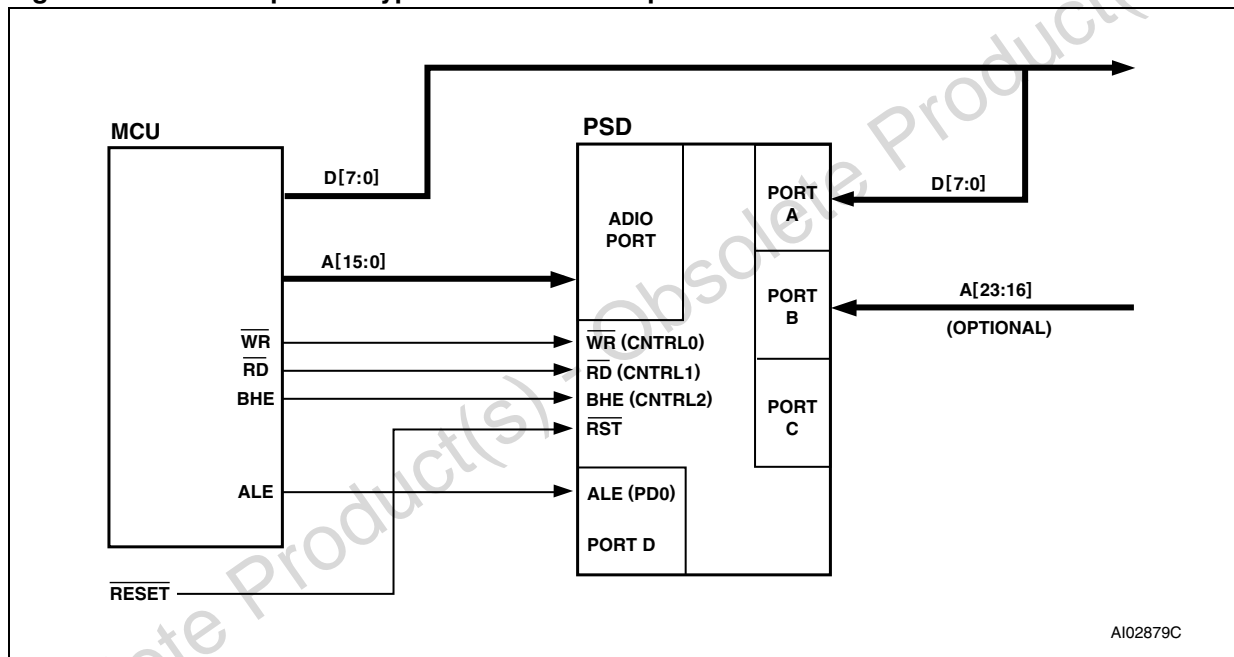

15.5 80C31

Figure 20 shows the bus interface for the 80C31, which has an 8-bit multiplexed address/data bus. The lower address byte is multiplexed with the data bus. The MCU control signals Program Select Enable (PSEN, CNTL2), Read Strobe (RD, CNTL1), and Write Strobe (WR, CNTL0) may be used for accessing the internal memory and I/O ports blocks. Address Strobe (ALE/AS, PD0) latches the address.

Figure 20. Interfacing the PSD with an 80C31

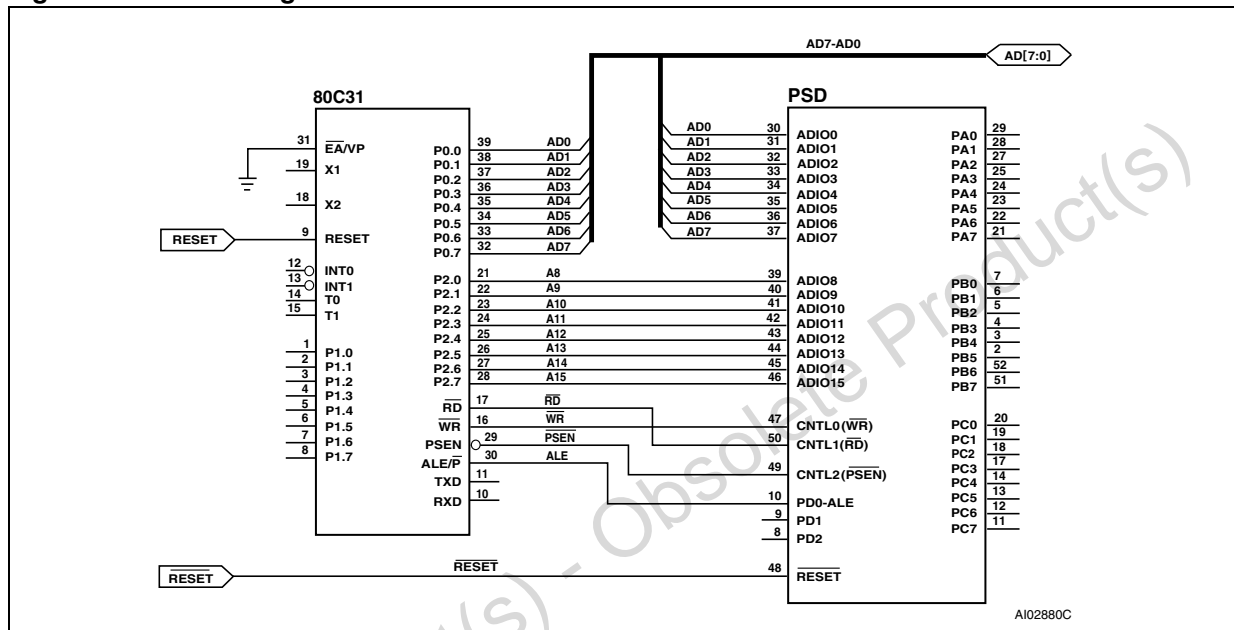

AI02880C

15.6 80C251

The Intel 80C251 MCU features a user-configurable bus interface with four possible bus configurations, as shown in [Table 19](#).

The first configuration is 80C31-compatible, and the bus interface to the PSD is identical to that shown in [Figure 20](#). The second and third configurations have the same bus connection as shown in [Figure 21](#). There is only one Read Strobe (PSEN) connected to CNTL1 on the PSD. The A16 connection to PA0 allows for a larger address input to the PSD. The fourth configuration is shown in [Figure 22](#). Read Strobe (RD) is connected to CNTL1 and Program Select Enable (PSEN) is connected to CNTL2.

The 80C251 has two major operating modes: Page mode and Non-page mode. In Non-page mode, the data is multiplexed with the lower address byte, and Address Strobe (ALE/AS, PD0) is active in every bus cycle. In Page mode, data (D7-D0) is multiplexed with address (A15-A8). In a bus cycle where there is a Page hit, Address Strobe (ALE/AS, PD0) is not active and only addresses (A7-A0) are changing. The PSD supports both modes. In Page mode, the PSD bus timing is identical to Non-Page mode except the address hold time and setup time with respect to Address Strobe (ALE/AS, PD0) is not required. The PSD access time is measured from address (A7-A0) valid to data in valid.

Figure 21. Interfacing the PSD with the 80C251, with One READ input

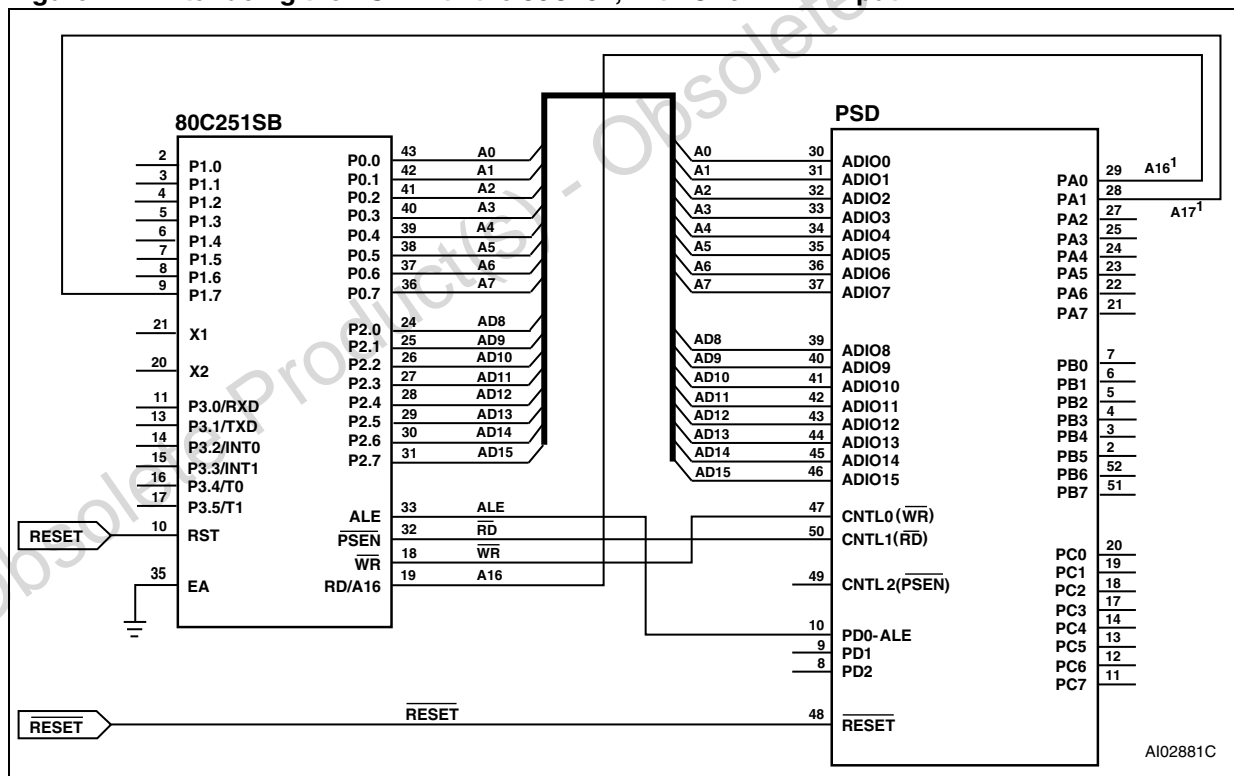

1. The A16 and A17 connections are optional.
2. In non-Page-mode, AD7-AD0 connects to ADIO7-ADIO0.

Figure 22. Interfacing the PSD with the 80C251, with \overline{RD} and \overline{PSEN} inputs

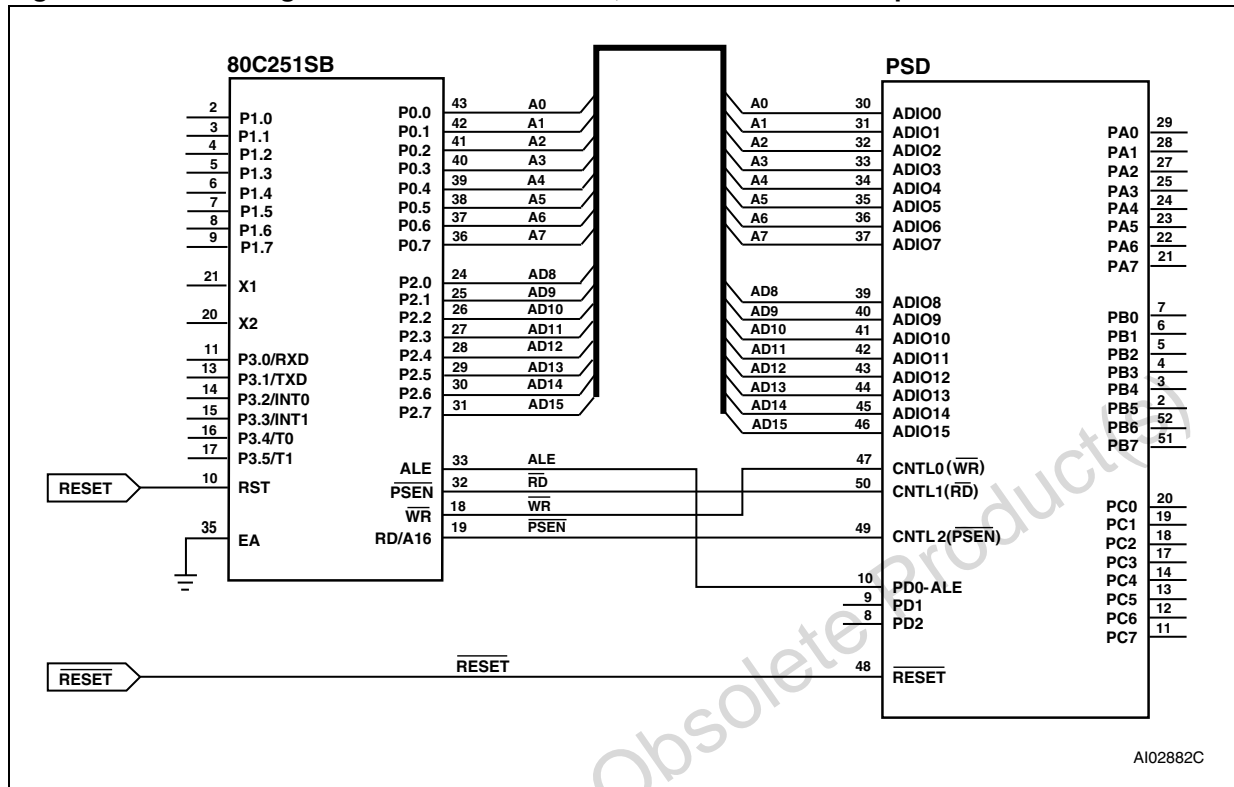

AI02882C

Table 19. 80C251 configurations

Configuration	80C251 READ/WRITE pins	Connecting to PSD pins	Page mode
1	\overline{WR} \overline{RD} \overline{PSEN}	CNTL0 CNTL1 CNTL2	Non-Page mode, 80C31 compatible A7-A0 multiplex with D7-D0
2	\overline{WR} \overline{PSEN} only	CNTL0 CNTL1	Non-Page mode A7-A0 multiplex with D7-D0
3	\overline{WR} \overline{PSEN} only	CNTL0 CNTL1	Page mode A15-A8 multiplex with D7-D0
4	\overline{WR} \overline{RD} \overline{PSEN}	CNTL0 CNTL1 CNTL2	Page mode A15-A8 multiplex with D7-D0

15.7 80C51XA

The Philips 80C51XA MCU family supports an 8- or 16-bit multiplexed bus that can have burst cycles. Address bits (A3-A0) are not multiplexed, while (A19-A4) are multiplexed with data bits (D15-D0) in 16-bit mode. In 8-bit mode, (A11-A4) are multiplexed with data bits (D7-D0).

The 80C51XA can be configured to operate in eight-bit data mode (as shown in *Figure 23*).

The 80C51XA improves bus throughput and performance by executing burst cycles for code fetches. In Burst mode, address A19-A4 are latched internally by the PSD, while the 80C51XA changes the A3-A0 signals to fetch up to 16 bytes of code. The PSD access time is then measured from address A3-A0 valid to data in valid. The PSD bus timing requirement in Burst mode is identical to the normal bus cycle, except the address setup and hold time with respect to Address Strobe (ALE/AS, PD0) does not apply.

Figure 23. Interfacing the PSD with the 80C51X, 8-bit data bus

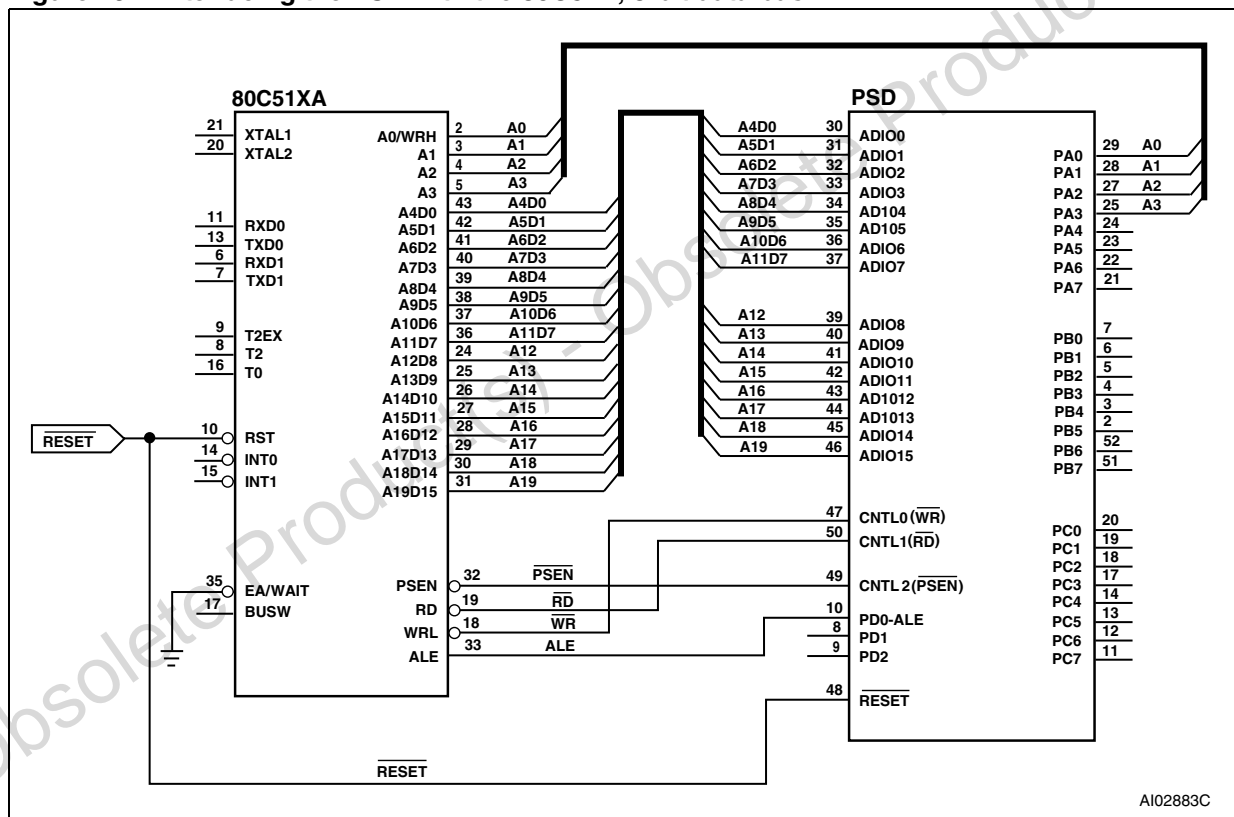

15.8 68HC11

Figure 24 shows a bus interface to a 68HC11 where the PSD is configured in 8-bit multiplexed mode with E and R/W settings. The DPLD can be used to generate the READ and WR signals for external devices.

Figure 24. Interfacing the PSD with a 68HC11

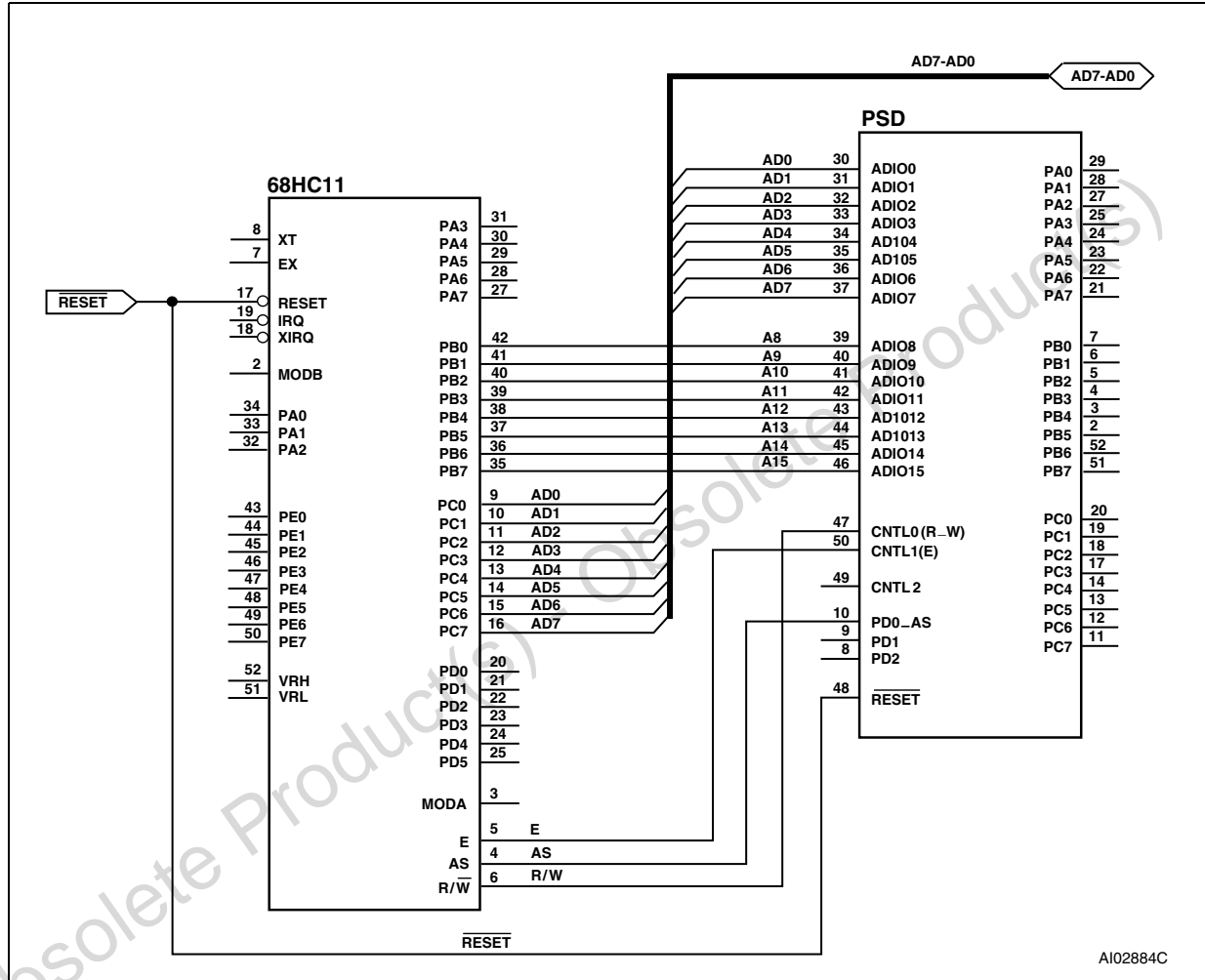

16 I/O ports

There are four programmable I/O ports: ports A, B, C, and D. Each of the ports is eight bits except port D, which is 3 bits. Each port pin is individually user configurable, thus allowing multiple functions per port. The ports are configured using PSDsoft Express Configuration or by the MCU writing to on-chip registers in the CSIOP space.

The topics discussed in this section are:

- General port architecture
- Port operating modes
- Port configuration registers (PCR)
- Port Data registers
- Individual port functionality.

16.1 General port architecture

The general architecture of the I/O port block is shown in [Figure 25](#). Individual port architectures are shown in [Figure 27](#), [Figure 28](#), [Figure 29](#), and [Figure 30](#). In general, once the purpose for a port pin has been defined, that pin is no longer available for other purposes. Exceptions are noted.

As shown in [Figure 25](#), the ports contain an output multiplexer whose select signals are driven by the configuration bits in the Control registers (Ports A and B only) and PSDsoft Express Configuration. Inputs to the multiplexer include the following:

- Output data from the Data Out register
- Latched address outputs
- CPLD macrocell output
- External Chip Select (ECS0-ECS2) from the CPLD.

The port Data Buffer (PDB) is a tri-state buffer that allows only one source at a time to be read. The port Data Buffer (PDB) is connected to the Internal data bus for feedback and can be read by the MCU. The Data Out and macrocell outputs, Direction and Control registers, and port pin input are all connected to the port data buffer (PDB).

The port pin's tri-state output driver enable is controlled by a two input OR gate whose inputs come from the CPLD AND Array enable product term and the Direction register. If the enable product term of any of the Array outputs are not defined and that port pin is not defined as a CPLD output in the PSDabel file, then the Direction register has sole control of the buffer that drives the port pin.

The contents of these registers can be altered by the MCU. The port Data Buffer (PDB) feedback path allows the MCU to check the contents of the registers.

Ports A, B, and C have embedded input macrocells (IMC). The input macrocells (IMC) can be configured as latches, registers, or direct inputs to the PLDs. The latches and registers are clocked by Address Strobe (ALE/AS, PD0) or a product term from the PLD AND Array. The outputs from the input macrocells (IMC) drive the PLD input bus and can be read by the MCU (see [Figure 16: Input macrocell](#)).

16.2 Port operating modes

The I/O ports have several modes of operation. Some modes can be defined using PSDabel, some by the MCU writing to the Control registers in CSIOP space, and some by both. The modes that can only be defined using PSDsoft Express must be programmed into the device and cannot be changed unless the device is reprogrammed. The modes that can be changed by the MCU can be done so dynamically at run-time. The PLD I/O, Data port, Address input, and Peripheral I/O modes are the only modes that must be defined before programming the device. All other modes can be changed by the MCU at run-time. See Application Note AN1171 for more detail.

Table 20 summarizes which modes are available on each port. Table 23 shows how and where the different modes are configured. Each of the port operating modes are described in the following sections.

Figure 25. General I/O port architecture

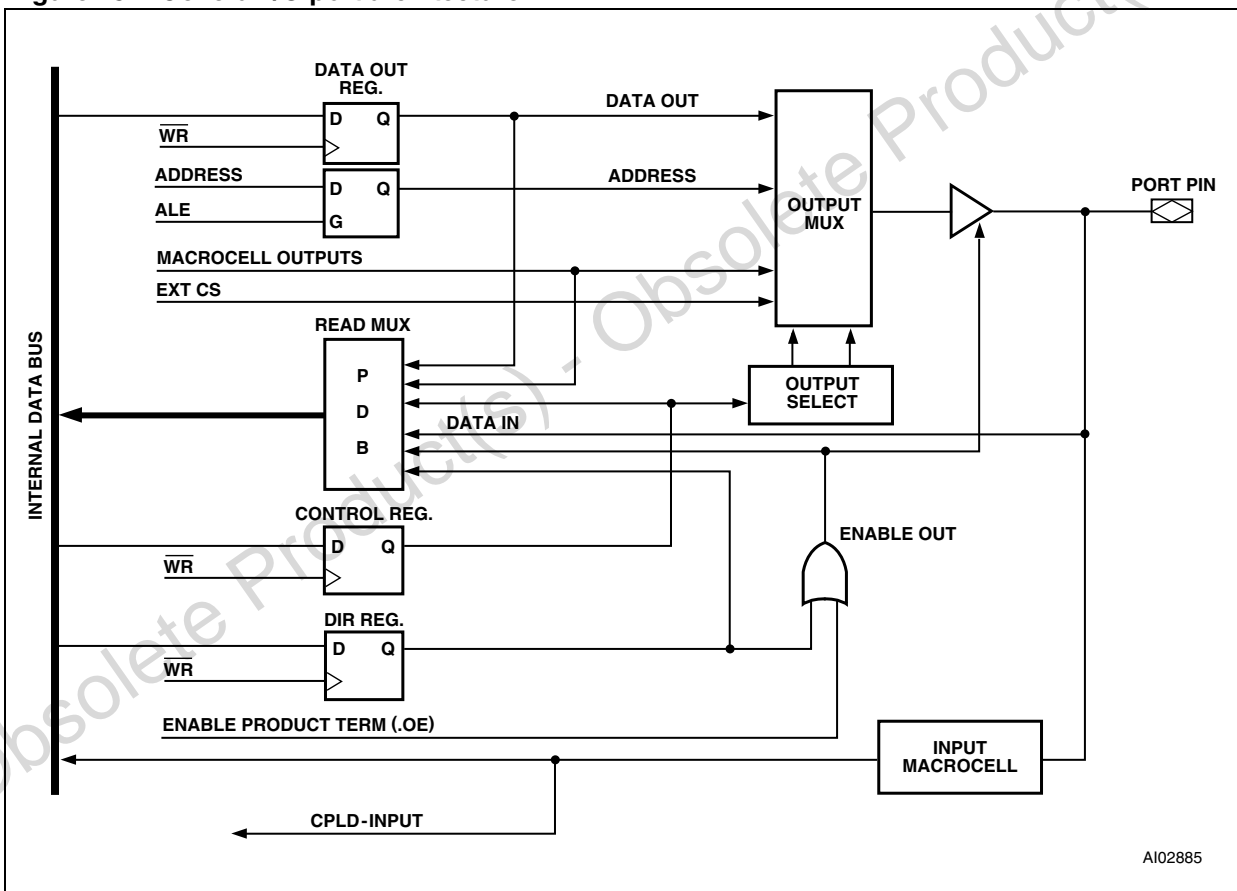

16.3 MCU I/O mode

In the MCU I/O mode, the MCU uses the I/O ports block to expand its own I/O ports. By setting up the CSIOP space, the ports on the PSD are mapped into the MCU address space. The addresses of the ports are listed in [Table 8](#).

A port pin can be put into MCU I/O mode by writing a 0 to the corresponding bit in the Control register. The MCU I/O direction may be changed by writing to the corresponding bit in the Direction register, or by the output enable product term (see [Section 16.8: Peripheral I/O mode](#)). When the pin is configured as an output, the content of the Data Out register drives the pin. When configured as an input, the MCU can read the port input through the Data In buffer (see [Figure 25](#)).

Ports C and D do not have Control registers, and are in MCU I/O mode by default. They can be used for PLD I/O if equations are written for them in PSDabel.

16.4 PLD I/O mode

The PLD I/O mode uses a port as an input to the CPLD's input macrocells (IMC), and/or as an output from the CPLD's Output macrocells (OMC). The output can be tri-stated with a control signal. This output enable control signal can be defined by a product term from the PLD, or by resetting the corresponding bit in the Direction register to '0.' The corresponding bit in the Direction register must not be set to '1' if the pin is defined for a PLD input signal in PSDabel. The PLD I/O mode is specified in PSDabel by declaring the port pins, and then writing an equation assigning the PLD I/O to a port.

16.5 Address Out mode

For MCUs with a multiplexed address/data bus, Address Out mode can be used to drive latched addresses on to the port pins. These port pins can, in turn, drive external devices. Either the output enable or the corresponding bits of both the Direction register and Control register must be set to a 1 for pins to use Address Out mode. This must be done by the MCU at run-time. See [Table 22](#) for the address output pin assignments on ports A and B for various MCUs.

For non-multiplexed 8-bit bus mode, address signals (A7-A0) are available to port B in Address Out mode.

Note: Do not drive address signals with Address Out mode to an external memory device if it is intended for the MCU to Boot from the external device. The MCU must first Boot from PSD memory so the Direction and Control register bits can be set.

Table 20. Port operating modes

Port mode	Port A	Port B	Port C	Port D
MCU I/O	Yes	Yes	Yes	Yes
PLD I/O				
McellAB outputs	Yes	Yes	No	No
McellBC outputs	No	Yes	Yes	No
Additional Ext. CS outputs	No	No	No	Yes
PLD inputs	Yes	Yes	Yes	Yes

Table 20. Port operating modes (continued)

Port mode	Port A	Port B	Port C	Port D
Address Out	Yes (A7 – 0)	Yes (A7 – 0) or (A15 – 8)	No	No
Address In	Yes	Yes	Yes	Yes
Data port	Yes (D7 – 0)	No	No	No
Peripheral I/O	Yes	No	No	No
JTAG ISP	No	No	Yes ⁽¹⁾	No

1. Can be multiplexed with other I/O functions.

Table 21. Port operating mode settings

Mode	Defined in PSDlabel	Defined in PSD configuration	Control register setting	Direction register setting	VM register setting	JTAG Enable
MCU I/O	Declare pins only	N/A ⁽¹⁾	0	1 = output, 0 = input ⁽²⁾	N/A	N/A
PLD I/O	Logic equations	N/A	N/A	⁽²⁾	N/A	N/A
Data port (Port A)	N/A	Specify bus type	N/A	N/A	N/A	N/A
Address Out (Port A,B)	Declare pins only	N/A	1	1 ⁽²⁾	N/A	N/A
Address In (Port A,B,C,D)	Logic for equation input macrocells	N/A	N/A	N/A	N/A	N/A
Peripheral I/O (Port A)	Logic equations (PSEL0 & 1)	N/A	N/A	N/A	PIO bit = 1	N/A
JTAG ISP ⁽³⁾	JTAGSEL	JTAG Configuration	N/A	N/A	N/A	JTAG_Enable

1. N/A = Not Applicable

2. The direction of the port A,B,C, and D pins are controlled by the Direction register ORed with the individual output enable product term (.oe) from the CPLD AND Array.

3. Any of these three methods enables the JTAG pins on port C.

Table 22. I/O port Latched address output assignments

MCU	Port A (PA3-PA0)	Port A (PA7-PA4)	Port B (PB3-PB0)	Port B (PB7-PB4)
8051XA (8-Bit)	N/A ⁽¹⁾	Address a7-a4	Address a11-a8	N/A
80C251 (Page mode)	N/A	N/A	Address a11-a8	Address a15-a12
All Other 8-Bit Multiplexed	Address a3-a0	Address a7-a4	Address a3-a0	Address a7-a4
8-Bit Non-Multiplexed bus	N/A	N/A	Address a3-a0	Address a7-a4

1. N/A = Not Applicable

16.6 Address In mode

For MCUs that have more than 16 address signals, the higher addresses can be connected to port A, B, C, and D. The address input can be latched in the input macrocell (IMC) by Address Strobe (ALE/AS, PD0). Any input that is included in the DPLD equations for the SRAM, or primary or secondary Flash memory is considered to be an address input.

16.7 Data port mode

Port A can be used as a data bus port for a MCU with a non-multiplexed address/data bus. The Data port is connected to the data bus of the MCU. The general I/O functions are disabled in port A if the port is configured as a Data port.

16.8 Peripheral I/O mode

Peripheral I/O mode can be used to interface with external peripherals. In this mode, all of port A serves as a tri-state, bi-directional data buffer for the MCU. Peripheral I/O mode is enabled by setting Bit 7 of the VM register to a '1'. [Figure 26](#) shows how port A acts as a bi-directional buffer for the MCU data bus if Peripheral I/O mode is enabled. An equation for PSEL0 and/or PSEL1 must be written in PSDabel. The buffer is tri-stated when PSEL0 or PSEL1 is not active.

Figure 26. Peripheral I/O mode

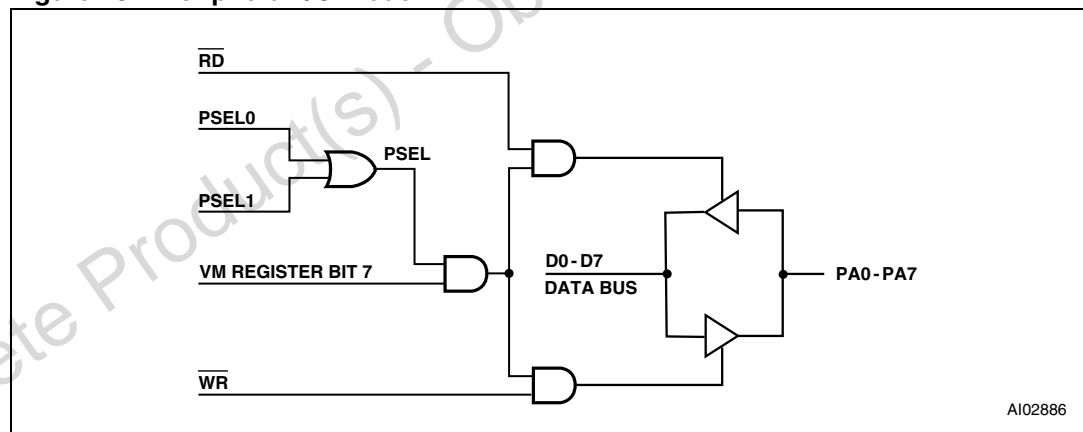

16.9 JTAG in-system programming (ISP)

Port C is JTAG compliant, and can be used for in-system programming (ISP). You can multiplex JTAG operations with other functions on port C because in-system programming (ISP) is not performed in normal operating mode. For more information on the JTAG port, see [Section 19: Programming in-circuit using the JTAG serial interface](#).

16.10 Port configuration registers (PCR)

Each port has a set of port configuration registers (PCR) used for configuration. The contents of the registers can be accessed by the MCU through normal READ/WRITE bus cycles at the addresses given in [Table 8](#). The addresses in [Table 8](#) are the offsets in hexadecimal from the base of the CSIOP register.

The pins of a port are individually configurable and each bit in the register controls its respective pin. For example, Bit 0 in a register refers to Bit 0 of its port. The three port configuration registers (PCR), shown in [Table 23](#), are used for setting the port configurations. The default Power-up state for each register in [Table 23](#) is 00h.

16.11 Control register

Any bit reset to '0' in the Control register sets the corresponding port pin to MCU I/O mode, and a '1' sets it to Address Out mode. The default mode is MCU I/O. Only ports A and B have an associated Control register.

16.12 Direction register

The Direction register, in conjunction with the output enable (except for port D), controls the direction of data flow in the I/O ports. Any bit set to '1' in the Direction register causes the corresponding pin to be an output, and any bit set to '0' causes it to be an input. The default mode for all port pins is input.

[Figure 27](#) and [Figure 28](#) show the port architecture diagrams for ports A/B and C, respectively. The direction of data flow for ports A, B, and C are controlled not only by the direction register, but also by the output enable product term from the PLD AND Array. If the output enable product term is not active, the Direction register has sole control of a given pin's direction.

An example of a configuration for a port with the three least significant bits set to output and the remainder set to input is shown in [Table 26](#). Since port D only contains three pins (shown in [Figure 30](#)), the Direction register for port D has only the three least significant bits active.

16.13 Drive Select register

The Drive Select register configures the pin driver as Open Drain or CMOS for some port pins, and controls the slew rate for the other port pins. An external pull-up resistor should be used for pins configured as Open Drain.

A pin can be configured as Open Drain if its corresponding bit in the Drive Select register is set to a '1.' The default pin drive is CMOS.

Note that the slew rate is a measurement of the rise and fall times of an output. A higher slew rate means a faster output response and may create more electrical noise. A pin operates in a high slew rate when the corresponding bit in the Drive register is set to '1.' The default rate is slow slew.

[Table 27](#) shows the Drive register for ports A, B, C, and D. It summarizes which pins can be configured as Open Drain outputs and which pins the slew rate can be set for.

Table 23. Port configuration registers (PCR)t

Register name	Port	MCU access
Control	A,B	WRITE/READ
Direction	A,B,C,D	WRITE/READ
Drive Select ⁽¹⁾	A,B,C,D	WRITE/READ

1. See [Table 27](#) for Drive register bit definition.

Table 24. Port Pin Direction Control, Output Enable P.T. not defined

Direction register bit	Port Pin mode
0	Input
1	Output

Table 25. Port Pin Direction Control, Output Enable P.T. defined

Direction register Bit	Output Enable P.T.	Port Pin mode
0	0	Input
0	1	Output
1	0	Output
1	1	Output

Table 26. Port Direction assignment example

Bit 7	Bit 6	Bit 5	Bit 4	Bit 3	Bit 2	Bit 1	Bit 0
0	0	0	0	0	1	1	1

Table 27. Drive register pin assignment

Drive register	Bit 7	Bit 6	Bit 5	Bit 4	Bit 3	Bit 2	Bit 1	Bit 0
Port A	Open Drain	Open Drain	Open Drain	Open Drain	Slew Rate	Slew Rate	Slew Rate	Slew Rate
Port B	Open Drain	Open Drain	Open Drain	Open Drain	Slew Rate	Slew Rate	Slew Rate	Slew Rate
Port C	Open Drain	Open Drain	Open Drain	Open Drain	Open Drain	Open Drain	Open Drain	Open Drain
Port D	NA ⁽¹⁾	NA ⁽¹⁾	NA ⁽¹⁾	NA ⁽¹⁾	NA ⁽¹⁾	Slew Rate	Slew Rate	Slew Rate

1. NA = Not Applicable.

16.14 Port Data registers

The port Data registers, shown in [Table 28](#), are used by the MCU to write data to or read data from the ports. [Table 28](#) shows the register name, the ports having each register type, and MCU access for each register type. The registers are described below.

16.15 Data In

Port pins are connected directly to the Data In buffer. In MCU I/O input mode, the pin input is read through the Data In buffer.

16.16 Data Out register

Stores output data written by the MCU in the MCU I/O output mode. The contents of the register are driven out to the pins if the Direction register or the output enable product term is set to '1.' The contents of the register can also be read back by the MCU.

Output macrocells (OMC)

The CPLD Output macrocells (OMC) occupy a location in the MCU's address space. The MCU can read the output of the Output macrocells (OMC). If the OMC Mask register bits are not set, writing to the macrocell loads data to the macrocell flip-flops (see [Section 14: PLDS](#)).

16.17 OMC Mask register

Each OMC Mask register bit corresponds to an Output macrocell (OMC) flip-flop. When the OMC Mask register bit is set to a 1, loading data into the Output macrocell (OMC) flip-flop is blocked. The default value is 0 or unblocked.

Table 28. Port Data registers

Register name	Port	MCU access
Data In	A,B,C,D	READ – input on pin
Data Out	A,B,C,D	WRITE/READ
Output macrocell	A,B,C	READ – outputs of macrocells WRITE – loading macrocells flip-flop
Mask macrocell	A,B,C	WRITE/READ – prevents loading into a given macrocell
Input macrocell	A,B,C	READ – outputs of the input macrocells
Enable Out	A,B,C	READ – the output enable control of the port driver

16.18 Input macro (IMC)

The input macrocells (IMC) can be used to latch or store external inputs. The outputs of the input macrocells (IMC) are routed to the PLD input bus, and can be read by the MCU (see [Section 14: PLDS](#)).

16.19 Enable Out

The Enable Out register can be read by the MCU. It contains the output enable values for a given port. A 1 indicates the driver is in output mode. A 0 indicates the driver is in tri-state and the pin is in input mode.

16.20 Ports A and B – functionality and structure

Ports A and B have similar functionality and structure, as shown in [Figure 27](#). The two ports can be configured to perform one or more of the following functions:

- MCU I/O mode
- CPLD Output – macrocells McellAB7-McellAB0 can be connected to port A or port B. McellBC7-McellBC0 can be connected to port B or port C.
- CPLD input – Via the input macrocells (IMC).
- Latched Address output – Provide latched address output as per [Table 22](#).
- Address In – Additional high address inputs using the input macrocells (IMC).
- Open Drain/Slew Rate – pins PA3-PA0 and PB3-PB0 can be configured to fast slew rate, pins PA7-PA4 and PB7-PB4 can be configured to Open Drain mode.
- Data port – port A to D7-D0 for 8 bit non-multiplexed bus
- Multiplexed Address/Data port for certain types of MCU bus interfaces.
- Peripheral mode – port A only

Figure 27. Port A and port B structure

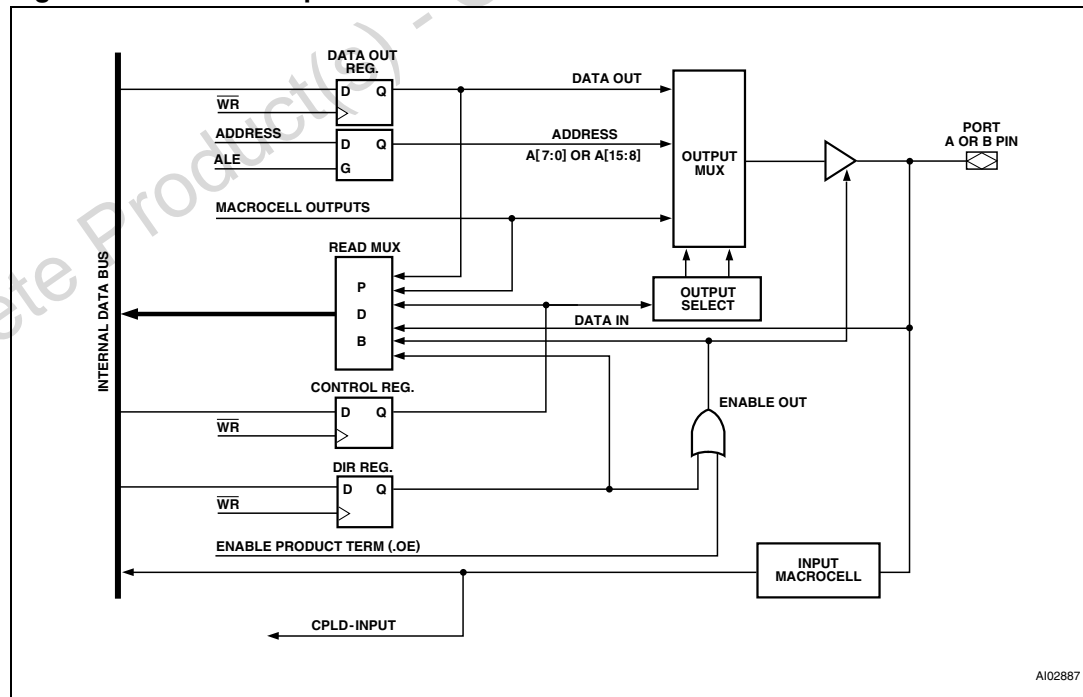

16.21 Port C – functionality and structure

Port C can be configured to perform one or more of the following functions (see [Figure 28](#)):

- MCU I/O mode
- CPLD Output – McellBC7-McellBC0 outputs can be connected to port B or port C.
- CPLD input – via the input macrocells (IMC)
- Address In – Additional high address inputs using the input macrocells (IMC).
- In-system programming (ISP) – JTAG port can be enabled for programming/erase of the PSD device (see [Section 19: Programming in-circuit using the JTAG serial interface](#) for more information on JTAG programming).
- Open Drain – port C pins can be configured in Open Drain mode

Port C does not support Address Out mode, and therefore no Control register is required.

Pin PC7 may be configured as the DBE input in certain MCU bus interfaces.

Figure 28. Port C structure

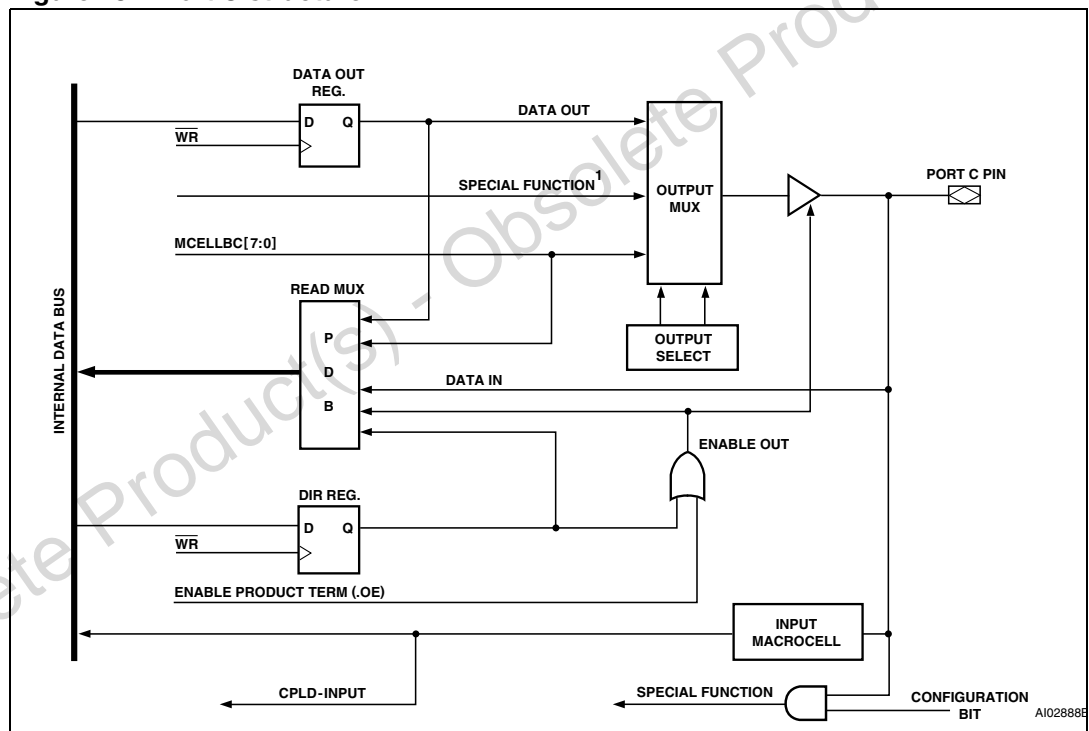

16.22 Port D – functionality and structure

Port D has three I/O pins. See [Figure 29](#) and [Figure 30](#). This port does not support Address Out mode, and therefore no Control register is required. port D can be configured to perform one or more of the following functions:

- MCU I/O mode
- CPLD Output – External Chip Select (ECS0-ECS2)
- CPLD input – direct input to the CPLD, no input macrocells (IMC)
- Slew rate – pins can be set up for fast slew rate

Port D pins can be configured in PSDsoft Express as input pins for other dedicated functions:

- Address Strobe (ALE/AS, PD0)
- CLKIN (PD1) as input to the macrocells flip-flops and APD counter
- PSD Chip Select input ($\overline{\text{CSI}}$, PD2). Driving this signal high disables the Flash memory, SRAM and CSIOP.

Figure 29. Port D structure

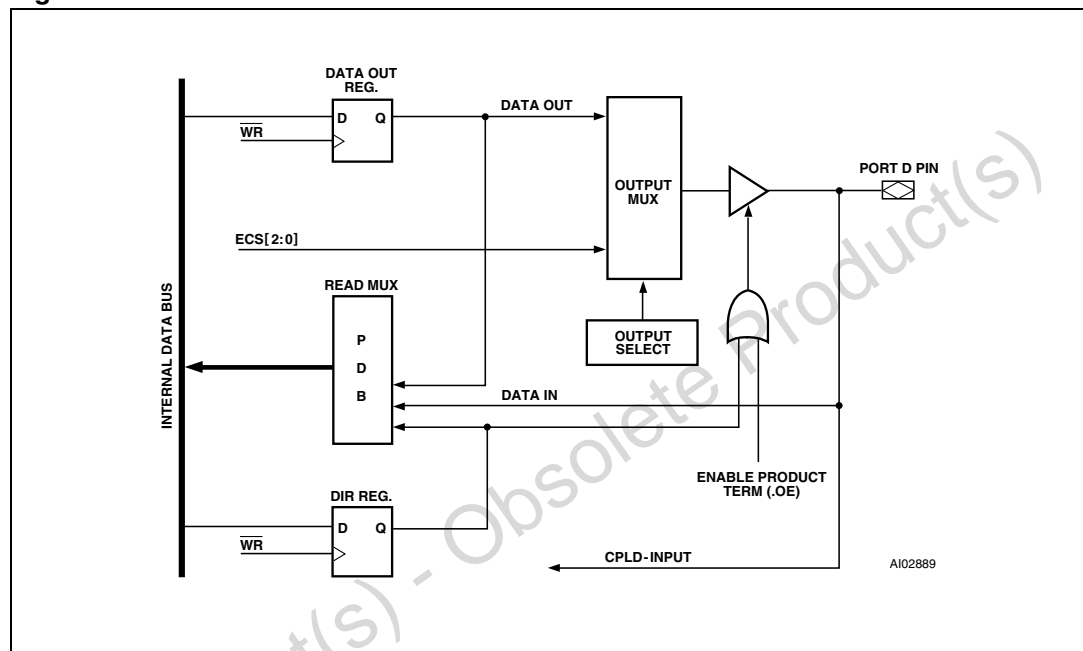

16.23 External Chip Select

The CPLD also provides three External Chip Select (ECS0-ECS2) outputs on port D pins that can be used to select external devices. Each External Chip Select (ECS0-ECS2) consists of one product term that can be configured active high or low. The output enable of the pin is controlled by either the output enable product term or the Direction register (see [Figure 30](#)).

Figure 30. Port D external Chip Select signals

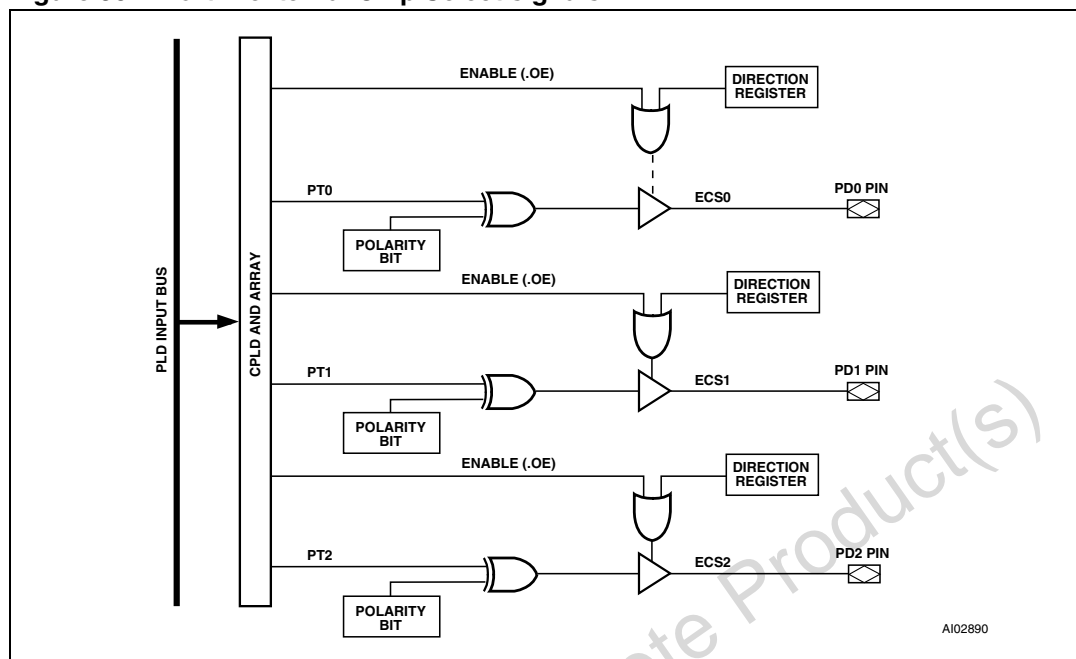

17 Power management

All PSD devices offer configurable power saving options. These options may be used individually or in combinations, as follows:

- All memory blocks in a PSD (primary and secondary Flash memory, and SRAM) are built with power management technology. In addition to using special silicon design methodology, power management technology puts the memories into standby mode when address/data inputs are not changing (zero DC current). As soon as a transition occurs on an input, the affected memory “wakes up”, changes and latches its outputs, then goes back to Standby. The designer does *not* have to do anything special to achieve memory Standby mode when no inputs are changing—it happens automatically.
The PLD sections can also achieve Standby mode when its inputs are not changing, as described in the sections on the Power Management mode registers (PMMR).
- As with the Power Management mode, the Automatic Power Down (APD) block allows the PSD to reduce to standby current automatically. The APD Unit can also block MCU address/data signals from reaching the memories and PLDs. This feature is available on all the devices of the PSD family. The APD Unit is described in more detail in [Section 17.1: Automatic Power-down \(APD\) Unit and Power-down mode](#).
Built in logic monitors the Address Strobe of the MCU for activity. If there is no activity for a certain time period (MCU is asleep), the APD Unit initiates Power-down mode (if enabled). Once in Power-down mode, all address/data signals are blocked from reaching PSD memory and PLDs, and the memories are deselected internally. This allows the memory and PLDs to remain in Standby mode even if the address/data signals are changing state externally (noise, other devices on the MCU bus, etc.). Keep in mind that any unblocked PLD input signals that are changing states keeps the PLD out of Standby mode, but not the memories.
- PSD Chip Select input ($\overline{CS1}$, PD2) can be used to disable the internal memories, placing them in Standby mode even if inputs are changing. This feature does not block any internal signals or disable the PLDs. This is a good alternative to using the APD Unit. There is a slight penalty in memory access time when PSD Chip Select input ($\overline{CS1}$, PD2) makes its initial transition from deselected to selected.
- The PMMRs can be written by the MCU at run-time to manage power. All PSD supports “blocking bits” in these registers that are set to block designated signals from reaching both PLDs. Current consumption of the PLDs is directly related to the composite frequency of the changes on their inputs (see [Figure 34](#) and [Figure 35](#)). Significant power savings can be achieved by blocking signals that are not used in DPLD or CPLD logic equations.
PSD devices have a Turbo Bit in PMMR0. This bit can be set to turn the Turbo mode off (the default is with Turbo mode turned on). While Turbo mode is off, the PLDs can achieve standby current when no PLD inputs are changing (zero DC current). Even when inputs do change, significant power can be saved at lower frequencies (AC current), compared to when Turbo mode is on. When the Turbo mode is on, there is a significant DC current component and the AC component is higher.

17.1 Automatic Power-down (APD) Unit and Power-down mode

The APD Unit, shown in [Figure 31](#), puts the PSD into Power-down mode by monitoring the activity of Address Strobe (ALE/AS, PD0). If the APD Unit is enabled, as soon as activity on Address Strobe (ALE/AS, PD0) stops, a four bit counter starts counting. If Address Strobe (ALE/AS, PD0) remains inactive for fifteen clock periods of CLKIN (PD1), Power-down (PDN) goes high, and the PSD enters Power-down mode, as discussed next.

Power-down mode

By default, if you enable the APD Unit, Power-down mode is automatically enabled. The device enters Power-down mode if Address Strobe (ALE/AS, PD0) remains inactive for fifteen periods of CLKIN (PD1).

The following should be kept in mind when the PSD is in Power-down mode:

- If Address Strobe (ALE/AS, PD0) starts pulsing again, the PSD returns to normal operating mode. The PSD also returns to normal operating mode if either PSD Chip Select input (\overline{CS} , PD2) is low or the Reset (\overline{RESET}) input is high.
- The MCU address/data bus is blocked from all memory and PLDs.
- Various signals can be blocked (prior to Power-down mode) from entering the PLDs by setting the appropriate bits in the PMMR registers. The blocked signals include MCU control signals and the common CLKIN (PD1). Note that blocking CLKIN (PD1) from the PLDs does not block CLKIN (PD1) from the APD Unit.
- All PSD memories enter Standby mode and are drawing standby current. However, the PLD and I/O ports blocks do *not* go into Standby mode because you don't want to have to wait for the logic and I/O to "wake up" before their outputs can change. See [Table 29](#) for Power-down mode effects on PSD ports.
- Typical standby current is of the order of microamperes. These standby current values assume that there are no transitions on any PLD input.

Table 29. Power-down mode's effect on ports

Port function	Pin level
MCU I/O	No change
PLD Out	No change
Address Out	Undefined
Data port	Tri-state
Peripheral I/O	Tri-state

Figure 31. APD unit

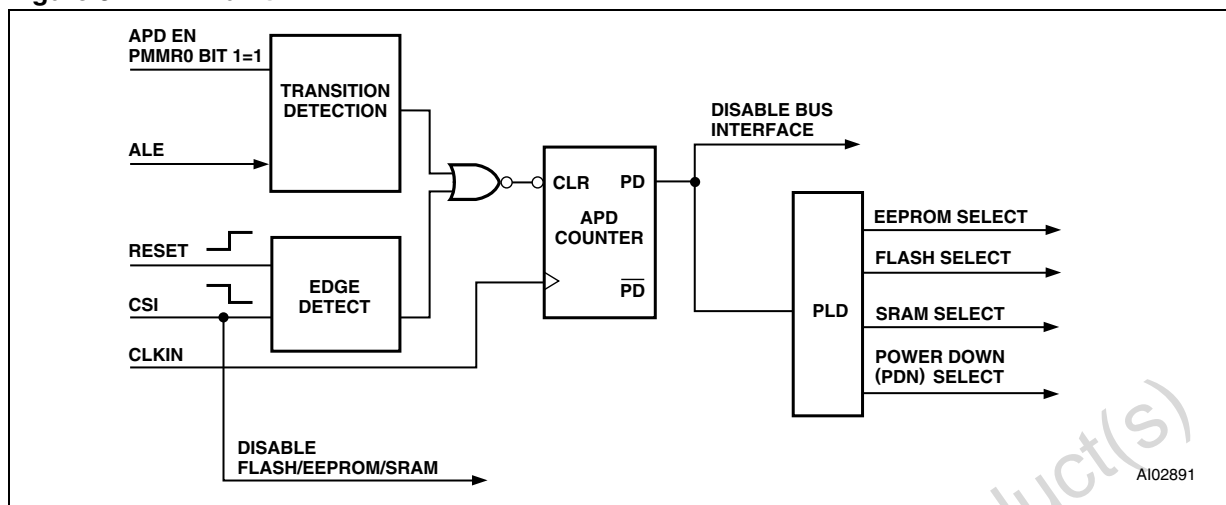

Table 30. PSD timing and standby current during Power-down mode

Mode	PLD propagation delay	Memory access time	Access recovery time to normal access	Typical standby current	
				5 V V _{CC}	3 V V _{CC}
Power-down	Normal t _{PD} ⁽¹⁾	No access	t _{LVDV}	75 μA ⁽²⁾	25 μA ⁽²⁾

1. Power-down does not affect the operation of the PLD. The PLD operation in this mode is based only on the Turbo Bit.
2. Typical current consumption assuming no PLD inputs are changing state and the PLD Turbo Bit is '0.'

17.2 For users of the HC11 (or compatible)

The HC11 turns off its E clock when it sleeps. Therefore, if you are using an HC11 (or compatible) in your design, and you wish to use the Power-down mode, you must not connect the E clock to CLKIN (PD1). You should instead connect a crystal oscillator to CLKIN (PD1). The crystal oscillator frequency must be *less than* 15 times the frequency of AS. The reason for this is that if the frequency is greater than 15 times the frequency of AS, the PSD keeps going into Power-down mode.

17.3 Other power saving options

The PSD offers other reduced power saving options that are independent of the Power-down mode. Except for PSD Chip Select input (\overline{CSI} , PD2) features, they are enabled by setting bits in PMMR0 and PMMR2.

Figure 32. Enable Power-down flowchart

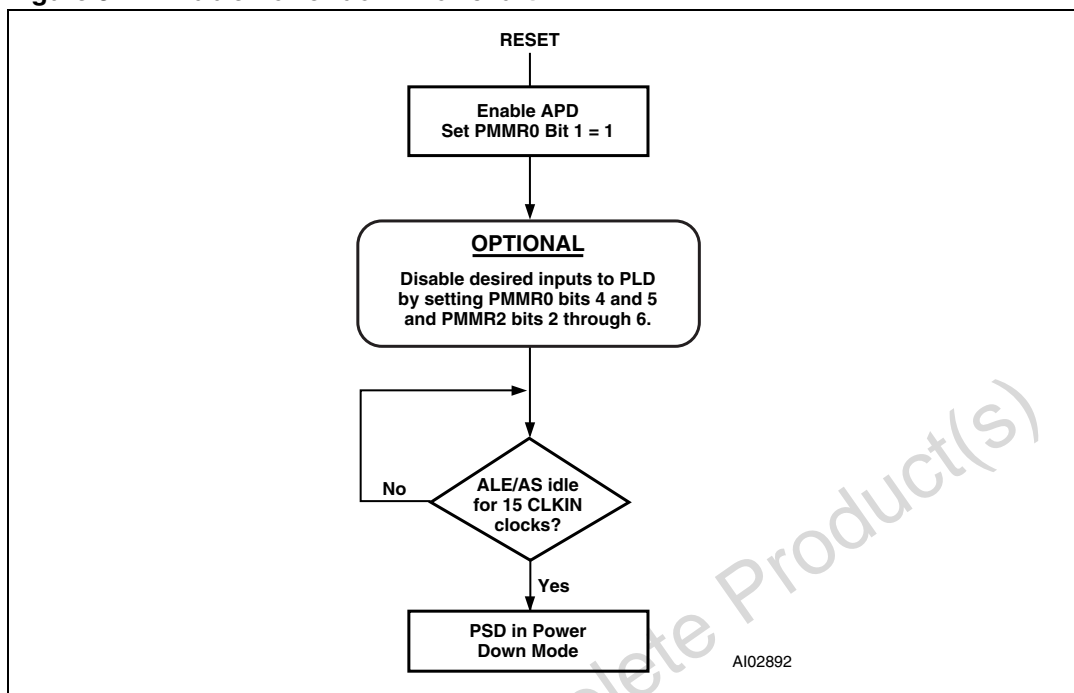

17.4 PLD power management

The power and speed of the PLDs are controlled by the Turbo Bit (Bit 3) in PMMR0. By setting the bit to '1,' the Turbo mode is off and the PLDs consume the specified standby current when the inputs are not switching for an extended time of 70ns. The propagation delay time is increased by 10ns after the Turbo Bit is set to '1' (turned off) when the inputs change at a composite frequency of less than 15 MHz. When the Turbo Bit is reset to '0' (turned on), the PLDs run at full power and speed. The Turbo Bit affects the PLD's DC power, AC power, and propagation delay.

Blocking MCU control signals with the bits of PMMR2 can further reduce PLD AC power consumption.

Table 31. Power Management mode registers PMMR0⁽¹⁾

Bit	Name	Description	
Bit 0	X	0	Not used, and should be set to zero.
Bit 1	APD Enable	0 = off	Automatic Power-down (APD) is disabled.
		1 = on	Automatic Power-down (APD) is enabled.
Bit 2	X	0	Not used, and should be set to zero.
Bit 3	PLD Turbo	0 = on	PLD Turbo mode is on
		1 = off	PLD Turbo mode is off, saving power.

Table 31. Power Management mode registers PMMR0⁽¹⁾ (continued)

Bit	Name	Description	
Bit 4	PLD Array clk	0 = on	CLKIN (PD1) input to the PLD AND Array is connected. Every change of CLKIN (PD1) Powers-up the PLD when Turbo Bit is '0.'
		1 = off	CLKIN (PD1) input to PLD AND Array is disconnected, saving power.
Bit 5	PLD MCell clk	0 = on	CLKIN (PD1) input to the PLD macrocells is connected.
		1 = off	CLKIN (PD1) input to PLD macrocells is disconnected, saving power.
Bit 6	X	0	Not used, and should be set to zero.
Bit 7	X	0	Not used, and should be set to zero.

1. The bits of this register are cleared to zero following Power-up. Subsequent Reset ($\overline{\text{RESET}}$) pulses do not clear the registers.

Table 32. Power Management mode registers PMMR2⁽¹⁾

Bit	Name	Description	
Bit 0	X	0	Not used, and should be set to zero.
Bit 1	X	0	Not used, and should be set to zero.
Bit 2	PLD Array CNTL0	0 = on	Cntl0 input to the PLD AND Array is connected.
		1 = off	Cntl0 input to PLD AND Array is disconnected, saving power.
Bit 3	PLD Array CNTL1	0 = on	Cntl1 input to the PLD AND Array is connected.
		1 = off	Cntl1 input to PLD AND Array is disconnected, saving power.
Bit 4	PLD Array CNTL2	0 = on	Cntl2 input to the PLD AND Array is connected.
		1 = off	Cntl2 input to PLD AND Array is disconnected, saving power.
Bit 5	PLD Array ALE	0 = on	ALE input to the PLD AND Array is connected.
		1 = off	ALE input to PLD AND Array is disconnected, saving power.
Bit 6	PLD Array DBE	0 = on	DBE input to the PLD AND Array is connected.
		1 = off	DBE input to PLD AND Array is disconnected, saving power.
Bit 7	X	0	Not used, and should be set to zero.

1. The bits of this register are cleared to zero following Power-up. Subsequent Reset ($\overline{\text{RESET}}$) pulses do not clear the registers.

17.5 PSD Chip Select input ($\overline{\text{CSI}}$, PD2)

PD2 of port D can be configured in PSDsoft Express as PSD Chip Select input ($\overline{\text{CSI}}$). When low, the signal selects and enables the internal Flash memory, EEPROM, SRAM, and I/O blocks for READ or WRITE operations involving the PSD. A high on PSD Chip Select input ($\overline{\text{CSI}}$, PD2) disables the Flash memory, EEPROM, and SRAM, and reduces the PSD power consumption. However, the PLD and I/O signals remain operational when PSD Chip Select input ($\overline{\text{CSI}}$, PD2) is high.

There may be a timing penalty when using PSD Chip Select input ($\overline{\text{CSI}}$, PD2) depending on the speed grade of the PSD that you are using. See the timing parameter t_{SLQV} in [Table 62](#) or [Table 63](#).

17.6 Input clock

The PSD provides the option to turn off CLKIN (PD1) to the PLD to save AC power consumption. CLKIN (PD1) is an input to the PLD AND Array and the Output macrocells (OMC).

During Power-down mode, or, if CLKIN (PD1) is not being used as part of the PLD logic equation, the clock should be disabled to save AC power. CLKIN (PD1) is disconnected from the PLD AND Array or the macrocells block by setting Bits 4 or 5 to a 1 in PMMR0.

17.7 Input control signals

The PSD provides the option to turn off the input control signals (CNTL0, CNTL1, CNTL2, Address Strobe (ALE/AS, PD0) and DBE) to the PLD to save AC power consumption. These control signals are inputs to the PLD AND Array. During Power-down mode, or, if any of them are not being used as part of the PLD logic equation, these control signals should be disabled to save AC power. They are disconnected from the PLD AND Array by setting Bits 2, 3, 4, 5, and 6 to a 1 in PMMR2.

Table 33. APD counter operation

APD Enable bit	ALE PD polarity	ALE level	APD counter
0	X	X	Not counting
1	X	Pulsing	Not counting
1	1	1	Counting (generates PDN after 15 clocks)
1	0	0	Counting (generates PDN after 15 clocks)

18 Reset timing and device status at reset

18.1 Power-up reset

Upon Power-up, the PSD requires a Reset ($\overline{\text{RESET}}$) pulse of duration $t_{\text{NLNH-PO}}$ after V_{CC} is steady. During this period, the device loads internal configurations, clears some of the registers and sets the Flash memory into operating mode. After the rising edge of Reset ($\overline{\text{RESET}}$), the PSD remains in the Reset mode for an additional period, t_{OPR} , before the first memory access is allowed.

The Flash memory is reset to the READ mode upon Power-up. Sector Select (FS0-FS7 and CSBOOT0-CSBOOT3) must all be low, Write Strobe ($\overline{\text{WR}}$, CNTL0) high, during Power On Reset for maximum security of the data contents and to remove the possibility of a byte being written on the first edge of Write Strobe ($\overline{\text{WR}}$, CNTL0). Any Flash memory WRITE cycle initiation is prevented automatically when V_{CC} is below V_{LKO} .

18.2 Warm reset

Once the device is up and running, the device can be reset with a pulse of a much shorter duration, t_{NLNH} .

The same t_{OPR} period is needed before the device is operational after warm reset. [Figure 33](#) shows the timing of the Power-up and warm reset.

18.3 I/O pin, register and PLD status at Reset

[Table 34](#) shows the I/O pin, register and PLD status during Power On Reset, warm reset and Power-down mode. PLD outputs are always valid during warm reset, and they are valid in Power On Reset once the internal PSD Configuration bits are loaded. This loading of PSD is completed typically long before the V_{CC} ramps up to operating level. Once the PLD is active, the state of the outputs are determined by the PSDLabel equations.

18.4 Reset of Flash memory erase and program cycles (on the PSD834Fx)

A Reset ($\overline{\text{RESET}}$) also resets the internal Flash memory state machine. During a Flash memory program or erase cycle, Reset ($\overline{\text{RESET}}$) terminates the cycle and returns the Flash memory to the Read mode within a period of $t_{\text{NLNH-A}}$.

Figure 33. Reset ($\overline{\text{RESET}}$) timing

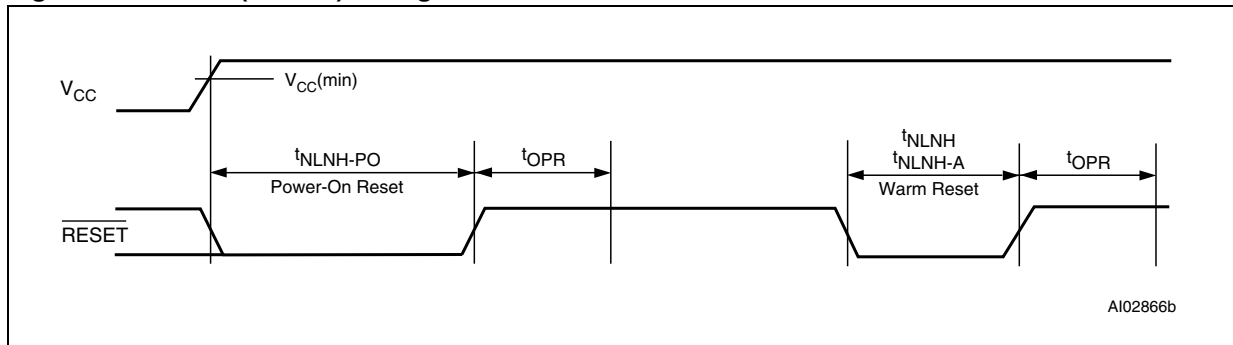

Table 34. Status during Power-on reset, Warm reset and Power-down mode

Port configuration	Power-on reset	Warm reset	Power-down mode
MCU I/O	Input mode	Input mode	Unchanged
PLD Output	Valid after internal PSD configuration bits are loaded	Valid	Depends on inputs to PLD (addresses are blocked in PD mode)
Address Out	Tri-stated	Tri-stated	Not defined
Data port	Tri-stated	Tri-stated	Tri-stated
Peripheral I/O	Tri-stated	Tri-stated	Tri-stated

Register	Power-on reset	Warm reset	Power-down mode
PMMR0 and PMMR2	Cleared to '0'	Unchanged	Unchanged
Macrocells flip-flop status	Cleared to '0' by internal Power-On Reset	Depends on .re and .pr equations	Depends on .re and .pr equations
VM register ⁽¹⁾	Initialized, based on the selection in PSDsoft Configuration menu	Initialized, based on the selection in PSDsoft Configuration menu	Unchanged
All other registers	Cleared to '0'	Cleared to '0'	Unchanged

1. The SR_cod and Periphmode bits in the VM register are always cleared to '0' on Power-on reset or Warm reset.

19 Programming in-circuit using the JTAG serial interface

The JTAG Serial Interface block can be enabled on port C (see [Table 35](#)). All memory blocks (primary and secondary Flash memory), PLD logic, and PSD Configuration register bits may be programmed through the JTAG Serial Interface block. A blank device can be mounted on a printed circuit board and programmed using JTAG.

The standard JTAG signals (IEEE 1149.1) are TMS, TCK, TDI, and TDO. Two additional signals, $\overline{\text{TSTAT}}$ and $\overline{\text{TERR}}$, are optional JTAG extensions used to speed up Program and Erase cycles.

Note: By default, on a blank PSD (as shipped from the factory or after erasure), four pins on port C are enabled for the basic JTAG signals TMS, TCK, TDI, and TDO.

See Application Note AN1153 for more details on JTAG in-system programming (ISP).

19.1 Standard JTAG signals

The standard JTAG signals (TMS, TCK, TDI, and TDO) can be enabled by any of three different conditions that are logically ORed. When enabled, TDI, TDO, TCK, and TMS are inputs, waiting for a JTAG serial command from an external JTAG controller device (such as FlashLINK or Automated Test Equipment). When the enabling command is received, TDO becomes an output and the JTAG channel is fully functional inside the PSD. The same command that enables the JTAG channel may optionally enable the two additional JTAG signals, $\overline{\text{TSTAT}}$ and $\overline{\text{TERR}}$.

The following symbolic logic equation specifies the conditions enabling the four basic JTAG signals (TMS, TCK, TDI, and TDO) on their respective port C pins. For purposes of discussion, the logic label JTAG_ON is used. When JTAG_ON is true, the four pins are enabled for JTAG. When JTAG_ON is false, the four pins can be used for general PSD I/O.

```
JTAG_ON = PSDsoft_enabled +
/* An NVM configuration bit inside the PSD is set by the designer
in the PSDsoft Express Configuration utility. This dedicates the
pins for JTAG at all times (compliant with IEEE 1149.1 */
Microcontroller_enabled +
/* The microcontroller can set a bit at run-time by writing to the
PSD register, JTAG Enable. This register is located at address CSIOp
+ offset C7h. Setting the JTAG_ENABLE bit in this register will
enable the pins for JTAG use. This bit is cleared by a PSD reset or
the microcontroller. See Table 36 for bit definition. */
PSD_product_term_enabled;
/* A dedicated product term (PT) inside the PSD can be used to
enable the JTAG pins. This PT has the reserved name JTAGSEL. Once
defined as a node in PSDlabel, the designer can write an equation for
JTAGSEL. This method is used when the port C JTAG pins are
multiplexed with other I/O signals. It is recommended to logically
tie the node JTAGSEL to the JEN\ signal on the Flashlink cable when
multiplexing JTAG signals. See Application Note 1153 for details. */
```

The state of the PSD Reset ($\overline{\text{RESET}}$) signal does not interrupt (or prevent) JTAG operations if the JTAG pins are dedicated by an NVM configuration bit (via PSDsoft Express). However,

Reset ($\overline{\text{RESET}}$) will prevent or interrupt JTAG operations if the JTAG enable register is used to enable the JTAG pins.

The PSD supports JTAG In-System-Configuration (ISC) commands, but not Boundary Scan. The PSDsoft Express software tool and FlashLINK JTAG programming cable implement the JTAG In-System-Configuration (ISC) commands. A definition of these JTAG In-System-Configuration (ISC) commands and sequences is defined in a supplemental document available from ST. This document is needed only as a reference for designers who use a FlashLINK to program their PSD.

19.2 JTAG extensions

$\overline{\text{TSTAT}}$ and $\overline{\text{TERR}}$ are two JTAG extension signals enabled by an "ISC_ENABLE" command received over the four standard JTAG signals (TMS, TCK, TDI, and TDO). They are used to speed Program and Erase cycles by indicating status on PSD signals instead of having to scan the status out serially using the standard JTAG channel. See Application Note *AN1153*.

$\overline{\text{TERR}}$ indicates if an error has occurred when erasing a sector or programming a byte in Flash memory. This signal goes low (active) when an Error condition occurs, and stays low until an "ISC_CLEAR" command is executed or a chip Reset ($\overline{\text{RESET}}$) pulse is received after an "ISC_DISABLE" command.

$\overline{\text{TSTAT}}$ behaves the same as Ready/Busy described in [Section 6.3.1: Ready/Busy \(PC3\)](#). $\overline{\text{TSTAT}}$ is high when the PSD device is in READ mode (primary and secondary Flash memory contents can be read). $\overline{\text{TSTAT}}$ is low when Flash memory program or erase cycles are in progress, and also when data is being written to the secondary Flash memory.

$\overline{\text{TSTAT}}$ and $\overline{\text{TERR}}$ can be configured as open-drain type signals during an "ISC_ENABLE" command. This facilitates a wired-OR connection of $\overline{\text{TSTAT}}$ signals from multiple PSD devices and a wired-OR connection of $\overline{\text{TERR}}$ signals from those same devices. This is useful when several PSD devices are "chained" together in a JTAG environment.

19.3 Security and Flash memory protection

When the security bit is set, the device cannot be read on a device programmer or through the JTAG port. When using the JTAG port, only a Full Chip Erase command is allowed.

All other Program, Erase and Verify commands are blocked. Full Chip Erase returns the part to a non-secured blank state. The Security bit can be set in PSDsoft Express configuration.

All primary and secondary Flash memory sectors can individually be sector protected against erasures. The sector protect bits can be set in PSDsoft Express configuration.

Table 35. JTAG port signals

Port C pin	JTAG signals	Description
PC0	TMS	mode Select
PC1	TCK	Clock
PC3	$\overline{\text{TSTAT}}$	Status
PC4	$\overline{\text{TERR}}$	Error flag
PC5	TDI	Serial Data In
PC6	TDO	Serial Data Out

Obsolete Product(s) - Obsolete Product(s)

20 Initial delivery state

When delivered from ST, the PSD device has all bits in the memory and PLDs set to '1.' The PSD Configuration register bits are set to '0.' The code, configuration, and PLD logic are loaded using the programming procedure. Information for programming the device is available directly from ST. Please contact your local sales representative.

Table 36. JTAG Enable register⁽¹⁾

Bit	Name	Description	
Bit 0	JTAG_Enable	0 = off	JTAG port is disabled.
		1 = on	JTAG port is enabled.
Bit 1	X	0	Not used, and should be set to zero.
Bit 2	X	0	Not used, and should be set to zero.
Bit 3	X	0	Not used, and should be set to zero.
Bit 4	X	0	Not used, and should be set to zero.
Bit 5	X	0	Not used, and should be set to zero.
Bit 6	X	0	Not used, and should be set to zero.
Bit 7	X	0	Not used, and should be set to zero.

1. The state of Reset (**RESET**) does not interrupt (or prevent) JTAG operations if the JTAG signals are dedicated by an NVM Configuration bit (via PSDsoft Express). However, Reset (**RESET**) prevents or interrupts JTAG operations if the JTAG enable register is used to enable the JTAG signals.

21 Maximum rating

Stressing the device above the rating listed in the Absolute Maximum Ratings” table may cause permanent damage to the device. These are stress ratings only and operation of the device at these or any other conditions above those indicated in the operating sections of this specification is not implied. Exposure to Absolute Maximum Rating conditions for extended periods may affect device reliability. Refer also to the STMicroelectronics SURE Program and other relevant quality documents.

Table 37. Absolute maximum ratings

Symbol	Parameter	Min.	Max.	Unit
T _{STG}	Storage temperature	-65	125	°C
T _{LEAD}	Lead temperature during soldering (20 seconds max.) ⁽¹⁾		235	°C
V _{IO}	Input and output voltage (Q = V _{OH} or Hi-Z)	-0.6	7.0	V
V _{CC}	Supply voltage	-0.6	7.0	V
V _{PP}	Device programmer supply voltage	-0.6	14.0	V
V _{ESD}	Electrostatic discharge voltage (human body model) ⁽²⁾	-2000	2000	V

1. IPC/JEDEC J-STD-020A

2. JEDEC Std JESD22-A114A (C1=100 pF, R1=1500 Ω, R2=500 Ω)

22 AC/DC parameters

This section summarizes the operating and measurement conditions, and the DC and AC characteristics of the device:

- DC electrical specifications
- AC timing specifications
 - PLD timings
 - Combinatorial timings
 - Synchronous clock mode
 - Asynchronous clock mode
 - Input macrocell timings
 - MCU timings
 - READ timings
 - WRITE timings
 - Peripheral mode timings
 - Power-down and Reset timings

The parameters in the DC and AC Characteristic tables that follow are derived from tests performed under the Measurement Conditions summarized in the relevant tables. Designers should check that the operating conditions in their circuit match the measurement conditions when relying on the quoted parameters.

The following are issues concerning the parameters presented:

- In the DC specification the supply current is given for different modes of operation. Before calculating the total power consumption, determine the percentage of time that the PSD is in each mode. Also, the supply power is considerably different if the Turbo Bit is '0.'
- The AC power component gives the PLD, Flash memory, and SRAM mA/MHz specification. [Figure 34](#) and [Figure 35](#) show the PLD mA/MHz as a function of the number of Product Terms (PT) used.
- In the PLD timing parameters, add the required delay when Turbo Bit is '0.'

Figure 34. PLD I_{CC}/frequency consumption (5 V range)

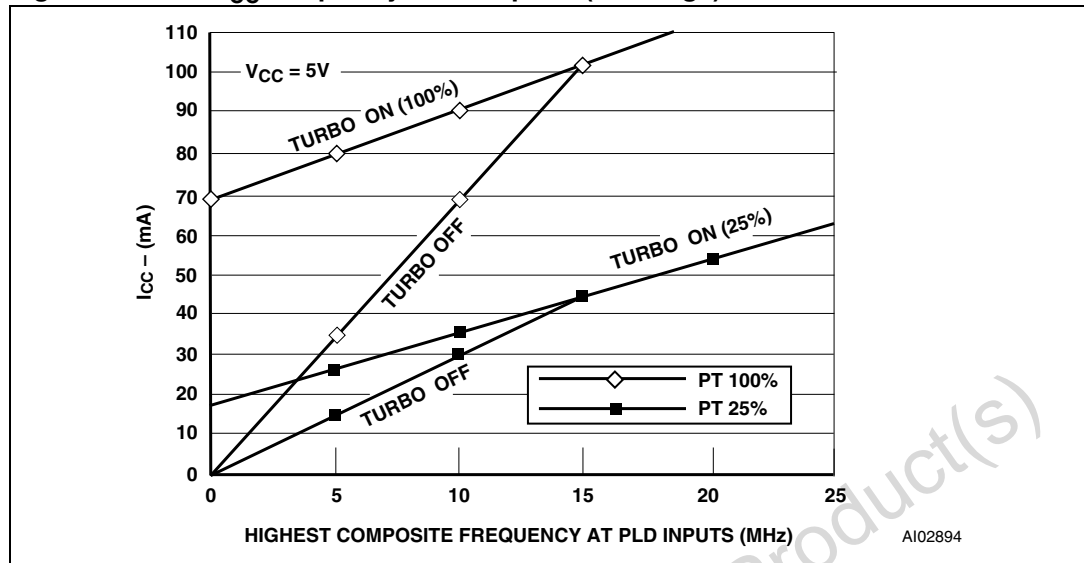

Figure 35. PLD I_{CC}/frequency consumption (3 V range)

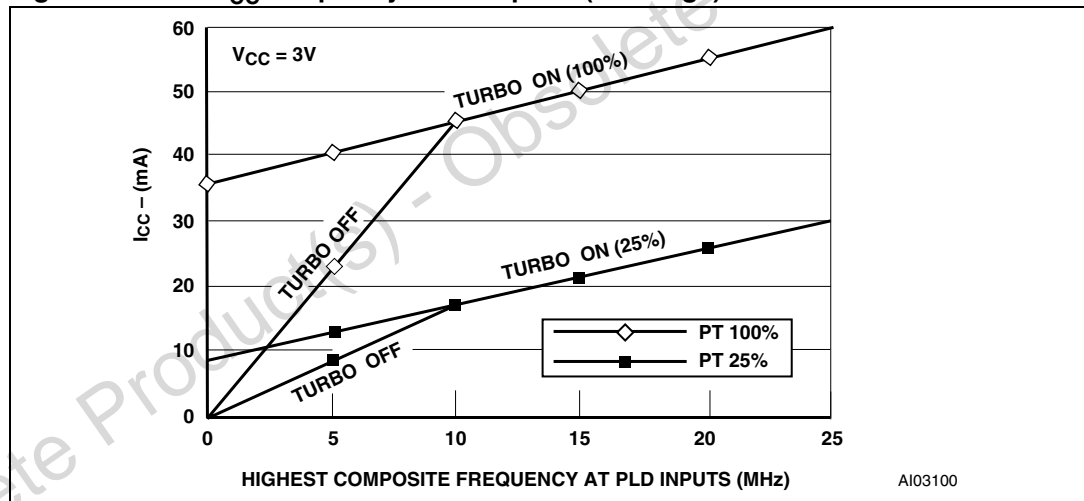

Table 38. Example of PSD typical power calculation at V_{CC}=5.0 V (Turbo mode on) ⁽¹⁾

Conditions		
Highest Composite PLD input frequency		
(Freq PLD)	=	8 MHz
MCU ALE frequency (Freq ALE)		
	=	4 MHz
% Flash memory access		
	=	80%
% SRAM access		
	=	15%
% I/O access		
	=	5% (no additional power above base)
Operational modes		
% Normal		
	=	10%
% Power-down mode		
	=	90%

Table 38. Example of PSD typical power calculation at V_{CC}=5.0 V (Turbo mode on) ⁽¹⁾

Conditions		
Number of product terms used		
	(from fitter report)	= 45 PT
	% of total product terms	= 45/182 = 24.7%
	Turbo mode	= ON
Calculation (using typical values)		
I _{CC} total	= I _{pwrdown} x %pwrdown + %normal x (I _{CC} (ac) + I _{CC} (dc))	
	= I _{pwrdown} x %pwrdown + % normal x (%flash x 2.5 mA/MHz x Freq ALE	
		+ %SRAM x 1.5 mA/MHz x Freq ALE
		+ % PLD x 2 mA/MHz x Freq PLD
		+ #PT x 400 μA/PT)
	= 50 μA x 0.90 + 0.1 x (0.8 x 2.5 mA/MHz x 4 MHz	
		+ 0.15 x 1.5 mA/MHz x 4 MHz
		+ 2 mA/MHz x 8 MHz
		+ 45 x 0.4 mA/PT)
	= 45 μA + 0.1 x (8 + 0.9 + 16 + 18 mA)	
	= 45 μA + 0.1 x 42.9	
	= 45 μA + 4.29 mA	
	= 4.34 mA	

1. This is the operating power with no EEPROM WRITE or Flash memory Erase cycles in progress. Calculation is based on I_{OUT} = 0 mA.

Table 39. Example of PSD typical power calculation at V_{CC} = 5.0 V (Turbo mode off) ⁽¹⁾

Conditions		
Highest Composite PLD input frequency		
	(Freq PLD)	= 8 MHz
MCU ALE frequency (Freq ALE)		
		= 4 MHz
	% Flash memory access	= 80%
	% SRAM access	= 15%
	% I/O access	= 5% (no additional power above base)
Operational modes		
	% Normal	= 10%
	% Power-down mode	= 90%
Number of product terms used		

Table 39. Example of PSD typical power calculation at V_{CC} = 5.0 V (Turbo mode off)

Conditions	
(from fitter report)	= 45 PT
% of total product terms	= 45/182 = 24.7%
Turbo mode	= Off
Calculation (using typical values)	
I _{CC} total	= I _{pwrdown} x %pwrdown + %normal x (I _{CC} (ac) + I _{CC} (dc))
	= I _{pwrdown} x %pwrdown + % normal x (%flash x 2.5mA/MHz x Freq ALE
	+ %SRAM x 1.5mA/MHz x Freq ALE
	+ % PLD x (from graph using Freq PLD))
	= 50 μA x 0.90 + 0.1 x (0.8 x 2.5mA/MHz x 4 MHz
	+ 0.15 x 1.5mA/MHz x 4 MHz
	+ 24mA)
	= 45 μA + 0.1 x (8 + 0.9 + 24)
	= 45 μA + 0.1 x 32.9
	= 45 μA + 3.29mA
	= 3.34mA

1. This is the operating power with no EEPROM WRITE or Flash memory Erase cycles in progress. Calculation is based on I_{OUT} = 0 mA.

Table 40. Operating conditions (5 V devices)

Symbol	Parameter	Min.	Max.	Unit
V _{CC}	Supply voltage	4.5	5.5	V
T _A	Ambient operating temperature (industrial)	-40	85	°C
	Ambient operating temperature (commercial)	0	70	°C

Table 41. Operating conditions (3 V devices)

Symbol	Parameter	Min.	Max.	Unit
V _{CC}	Supply voltage	3.0	3.6	V
T _A	Ambient operating temperature (industrial)	-40	85	°C
	Ambient operating temperature (commercial)	0	70	°C

Table 42. AC signal letters for PLD timing⁽¹⁾

Letter	Signal description
A	Address input
C	CEout output
D	Input data
E	E output
G	Internal WDOG_ON signal
I	Interrupt input
L	ALE input
N	$\overline{\text{RESET}}$ input or output
P	Port signal output
Q	Output data
R	$\overline{\text{WR}}$, $\overline{\text{UDS}}$, $\overline{\text{LDS}}$, $\overline{\text{DS}}$, $\overline{\text{IORD}}$, $\overline{\text{PSEN}}$ inputs
S	Chip Select input
T	$\text{R}/\overline{\text{W}}$ input
W	Internal PDN signal
M	Output macrocell

1. Example: t_{AVLX} = time from address valid to ALE invalid.

Table 43. AC signal behavior symbols for PLD timing⁽¹⁾

Letter	AC signal description
t	Time
L	Logic level low or ALE
H	Logic level high
V	Valid
X	No longer a valid logic level ⁽²⁾
Z	Float
PW	Pulse width

1. Example: t_{AVLX} = time from address valid to ALE invalid.

2. Output Hi-Z is defined as the point where data out is no longer driven.

Table 44. AC measurement conditions

Symbol	Parameter	Min.	Max.	Unit
C_L	Load capacitance		30	pF

Table 45. Capacitance⁽¹⁾

Symbol	Parameter	Test condition	Typ. ⁽²⁾	Max.	Unit
C_{IN}	Input capacitance (for input pins)	$V_{IN} = 0V$	4	6	pF
C_{OUT}	Output capacitance (for input/output pins)	$V_{OUT} = 0V$	8	12	pF
C_{VPP}	Capacitance (for CNTL2/ V_{PP})	$V_{PP} = 0V$	18	25	pF

1. Sampled only, not 100% tested.
2. Typical values are for $T_A = 25^\circ C$ and nominal supply voltages.

Figure 36. AC measurement I/O waveform

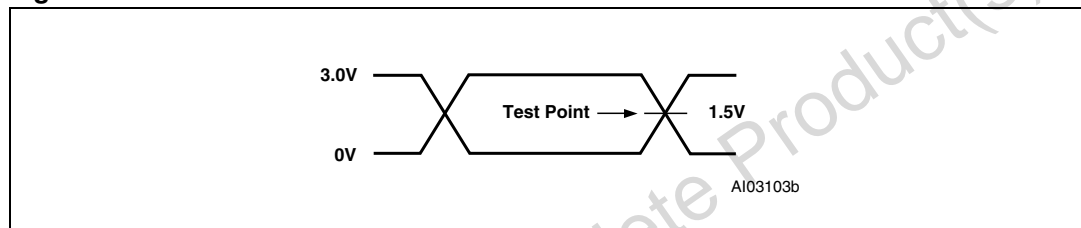

Figure 37. AC measurement load circuit

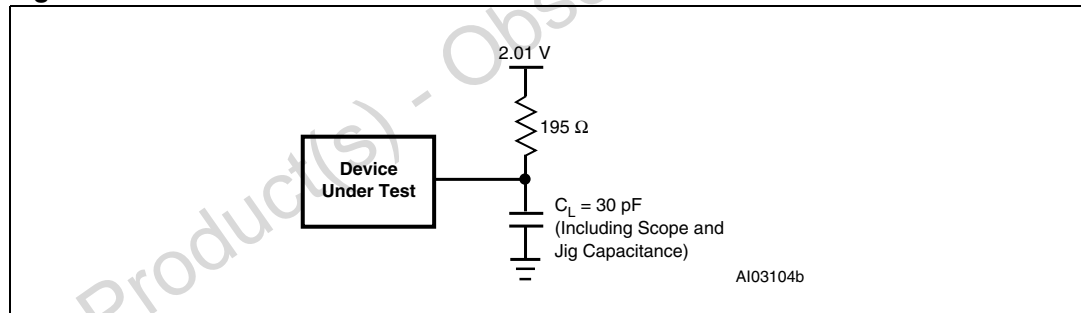

Figure 38. Switching waveforms – key

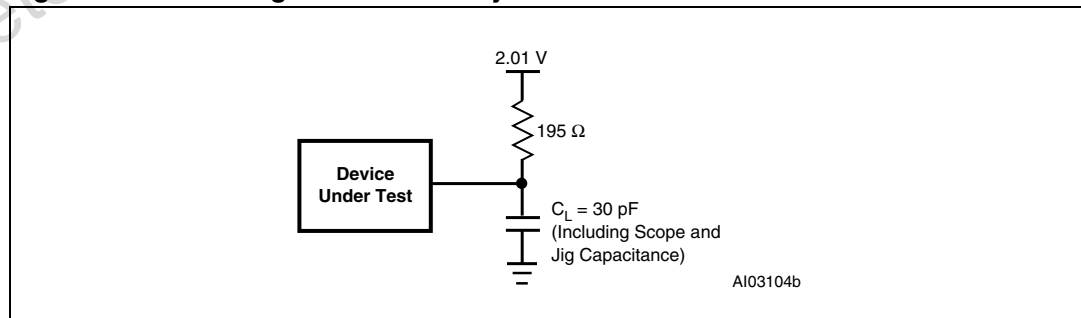

Table 46. DC characteristics (5 V devices)

Symbol	Parameter	Test condition (in addition to those in Table 40)	Min.	Typ.	Max.	Unit	
V _{IH}	Input high voltage	4.5 V < V _{CC} < 5.5 V	2		V _{CC} + 0.5	V	
V _{IL}	Input low voltage	4.5 V < V _{CC} < 5.5 V	-0.5		0.8	V	
V _{IH1}	Reset high level input voltage	(1)	0.8V _{CC}		V _{CC} + 0.5	V	
V _{IL1}	Reset low level input voltage	(1)	-0.5		0.2V _{CC} - 0.1	V	
V _{HYS}	Reset pin hysteresis		0.3			V	
V _{LKO}	V _{CC} (min) for Flash Erase and Program		2.5		4.2	V	
V _{OL}	Output low voltage	I _{OL} = 20 μA, V _{CC} = 4.5 V		0.01	0.1	V	
		I _{OL} = 8 mA, V _{CC} = 4.5 V		0.25	0.45	V	
V _{OH}	Output high voltage	I _{OH} = -20 μA, V _{CC} = 4.5 V	4.4	4.49		V	
		I _{OH} = -2 mA, V _{CC} = 4.5 V	2.4	3.9		V	
I _{SB}	Standby supply current for Power-down mode	$\overline{CS1} > V_{CC} - 0.3$ V ⁽²⁾⁽³⁾		50	200	μA	
I _{LI}	input leakage current	V _{SS} < V _{IN} < V _{CC}	-1	±0.1	1	μA	
I _{LO}	Output leakage current	0.45 < V _{OUT} < V _{CC}	-10	±5	10	μA	
I _{CC} (DC) ⁽⁴⁾	Operating supply current	PLD only	PLD_TURBO = off, f = 0 MHz ⁽⁴⁾		0		μA/PT
			PLD_TURBO = on, f = 0 MHz		400	700	μA/PT
		Flash memory	During Flash memory WRITE/Erase only		15	30	mA
			Read only, f = 0 MHz		0	0	mA
	SRAM	f = 0 MHz		0	0	mA	
I _{CC} (AC) ⁽⁴⁾	PLD AC adder				(5)		
	Flash memory AC adder			2.5	3.5	mA/MHz	
	SRAM AC adder			1.5	3.0	mA/MHz	

- Reset (\overline{RESET}) has hysteresis. V_{IL1} is valid at or below 0.2V_{CC} - 0.1. V_{IH1} is valid at or above 0.8V_{CC}.
- $\overline{CS1}$ deselected or internal Power-down mode is active.
- PLD is in non-Turbo mode, and none of the inputs are switching.
- I_{OUT} = 0 mA
- Please see [Figure 34](#) for the PLD current calculation.

Table 47. DC Characteristics (3 V devices)

Symbol	Parameter	Conditions	Min.	Typ.	Max.	Unit	
V_{IH}	High level input voltage	$3.0\text{ V} < V_{CC} < 3.6\text{ V}$	$0.7V_{CC}$		$V_{CC} + 0.5$	V	
V_{IL}	Low level input voltage	$3.0\text{ V} < V_{CC} < 3.6\text{ V}$	-0.5		0.8	V	
V_{IH1}	Reset high level input voltage	(1)	$0.8V_{CC}$		$V_{CC} + 0.5$	V	
V_{IL1}	Reset low level input voltage	(1)	-0.5		$0.2V_{CC} - 0.1$	V	
V_{HYS}	Reset pin hysteresis		0.3			V	
V_{LKO}	V_{CC} (min) for Flash Erase and Program		1.5		2.2	V	
V_{OL}	Output low voltage	$I_{OL} = 20\text{ }\mu\text{A}, V_{CC} = 3.0\text{ V}$		0.01	0.1	V	
		$I_{OL} = 4\text{ mA}, V_{CC} = 3.0\text{ V}$		0.15	0.45	V	
V_{OH}	Output high voltage	$I_{OH} = -20\text{ }\mu\text{A}, V_{CC} = 3.0\text{ V}$	2.9	2.99		V	
		$I_{OH} = -1\text{ mA}, V_{CC} = 3.0\text{ V}$	2.7	2.8		V	
I_{SB}	Standby supply current for Power-down mode	$\overline{CS1} > V_{CC} - 0.3\text{ V}^{(2)(3)}$		25	100	μA	
I_{LI}	Input leakage current	$V_{SS} < V_{IN} < V_{CC}$	-1	± 0.1	1	μA	
I_{LO}	Output leakage current	$0.45 < V_{IN} < V_{CC}$	-10	± 5	10	μA	
I_{CC} (DC) ⁽⁴⁾	Operating supply current	PLD only	PLD_TURBO = off, $f = 0\text{ MHz}^{(3)}$		0		$\mu\text{A/PT}$
			PLD_TURBO = on, $f = 0\text{ MHz}$		200	400	$\mu\text{A/PT}$
		Flash memory	During Flash memory WRITE/Erase only		10	25	mA
			Read only, $f = 0\text{ MHz}$		0	0	mA
		SRAM	$f = 0\text{ MHz}$		0	0	mA
I_{CC} (AC) ⁽⁴⁾	PLD AC adder			(5)			
	Flash memory AC adder			1.5	2.0	mA/MHz	
	SRAM AC adder			0.8	1.5	mA/MHz	

- Reset (RESET) has hysteresis. V_{IL1} is valid at or below $0.2V_{CC} - 0.1$. V_{IH1} is valid at or above $0.8V_{CC}$.
- $\overline{CS1}$ deselected or internal Power-down mode is active.
- PLD is in non-Turbo mode, and none of the inputs are switching.
- $I_{OUT} = 0\text{ mA}$
- Please see [Figure 35](#) for the PLD current calculation.

Figure 39. Input to output disable / enable

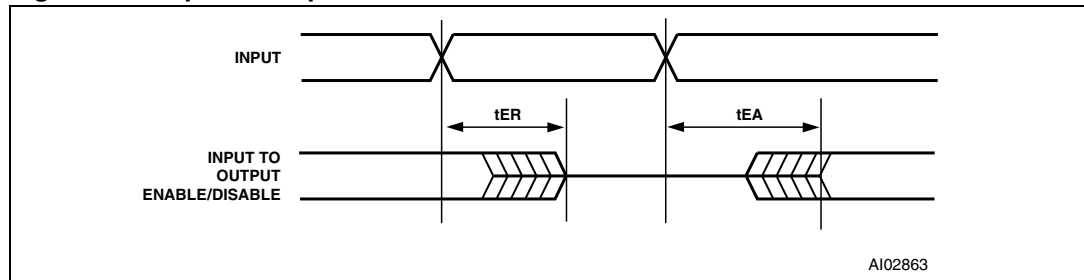

Table 48. CPLD combinatorial timing (5 V devices)

Symbol	Parameter	Conditions	-70		-90		-15		Fast PT Alloc	Turbo off	Slew rate (1)	Unit
			Min	Max	Min	Max	Min	Max				
t _{PD}	CPLD input pin/feedback to CPLD combinatorial output			20		25		32	+ 2	+ 10	- 2	ns
t _{EA}	CPLD input to CPLD output enable			21		26		32		+ 10	- 2	ns
t _{ER}	CPLD input to CPLD output disable			21		26		32		+ 10	- 2	ns
t _{ARP}	CPLD register clear or preset delay			21		26		33		+ 10	- 2	ns
t _{ARPW}	CPLD register clear or preset pulse width		10		20		29			+ 10		ns
t _{ARD}	CPLD array delay	Any macrocell		11		16		22	+ 2			ns

1. Fast Slew Rate output available on PA3-PA0, PB3-PB0, and PD2-PD0. Decrement times by given amount.

Table 49. CPLD combinatorial timing (3 V devices)

Symbol	Parameter	Conditions	-12		-15		-20		PT Alloc	Turbo off	Slew rate (1)	Unit
			Min	Max	Min	Max	Min	Max				
t _{PD}	CPLD input pin/feedback to CPLD combinatorial output			40		45		50	+ 4	+ 20	- 6	ns
t _{EA}	CPLD input to CPLD output enable			43		45		50		+ 20	- 6	ns
t _{ER}	CPLD input to CPLD output disable			43		45		50		+ 20	- 6	ns
t _{ARP}	CPLD register clear or preset delay			40		43		48		+ 20	- 6	ns

Table 49. CPLD combinatorial timing (3 V devices) (continued)

Symbol	Parameter	Conditions	-12		-15		-20		PT Alloc	Turbo off	Slew rate (1)	Unit
			Min	Max	Min	Max	Min	Max				
t _{ARPW}	CPLD register clear or preset pulse width		25		30		35			+ 20		ns
t _{ARD}	CPLD array delay	Any macrocell		25		29		33	+ 4			ns

1. Fast Slew Rate output available on PA3-PA0, PB3-PB0, and PD2-PD0. Decrement times by given amount.

Figure 40. Synchronous clock mode timing – PLD

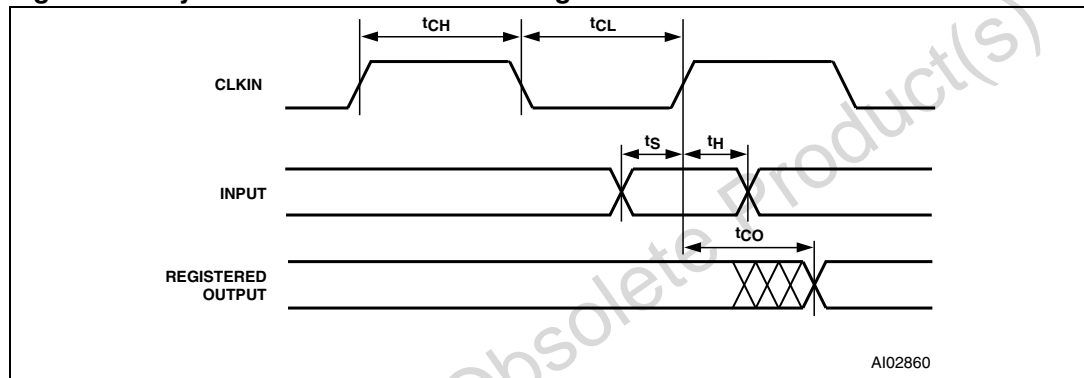

Table 50. CPLD macrocell Synchronous clock mode timing (5 V devices)

Symbol	Parameter	Conditions	-70		-90		-15		Fast PT Alloc	Turbo off	Slew rate (1)	Unit
			Min	Max	Min	Max	Min	Max				
f _{MAX}	Maximum frequency External feedback	1/(t _S +t _{CO})		40.0		30.30		25.00				MHz
	Maximum frequency Internal feedback (f _{CNT})	1/(t _S +t _{CO} -10)		66.6		43.48		31.25				MHz
	Maximum frequency Pipelined data	1/(t _{CH} +t _{CL})		83.3		50.00		35.71				MHz
t _S	Input setup time		12		15		20		+ 2	+ 10		ns
t _H	Input hold time		0		0		0					ns
t _{CH}	Clock high time	Clock input	6		10		15					ns
t _{CL}	Clock low time	Clock input	6		10		15					ns
t _{CO}	Clock to output delay	Clock input		13		18		22			- 2	ns

Table 50. CPLD macrocell Synchronous clock mode timing (5 V devices) (continued)

Symbol	Parameter	Conditions	-70		-90		-15		Fast PT Alloc	Turbo off	Slew rate (1)	Unit
			Min	Max	Min	Max	Min	Max				
t_{ARD}	CPLD array delay	Any macrocell		11		16		22	+ 2			ns
t_{MIN}	Minimum clock period ⁽²⁾	$t_{CH}+t_{CL}$	12		20		30					ns

1. Fast Slew Rate output available on PA3-PA0, PB3-PB0, and PD2-PD0. Decrement times by given amount.

2. CLKIN (PD1) $t_{CLCL} = t_{CH} + t_{CL}$.

Table 51. CPLD macrocell synchronous clock mode timing (3 V devices)

Symbol	Parameter	Conditions	-12		-15		-20		PT Alloc	Turbo off	Slew rate (1)	Unit
			Min	Max	Min	Max	Min	Max				
f_{MAX}	Maximum frequency External feedback	$1/(t_S+t_{CO})$		22.2		18.8		15.8				MHz
	Maximum frequency Internal feedback (f_{CNT})	$1/(t_S+t_{CO}-10)$		28.5		23.2		18.8				MHz
	Maximum frequency Pipelined data	$1/(t_{CH}+t_{CL})$		40.0		33.3		31.2				MHz
t_S	Input setup time		20		25		30		+ 4	+ 20		ns
t_H	Input hold time		0		0		0					ns
t_{CH}	Clock high time	Clock input	15		15		16					ns
t_{CL}	Clock low time	Clock input	10		15		16					ns
t_{CO}	Clock to output delay	Clock input		25		28		33			- 6	ns
t_{ARD}	CPLD array delay	Any macrocell		25		29		33	+ 4			ns
t_{MIN}	Minimum clock period ⁽²⁾	$t_{CH}+t_{CL}$	25		29		32					ns

1. Fast Slew Rate output available on PA3-PA0, PB3-PB0, and PD2-PD0. Decrement times by given amount.

2. CLKIN (PD1) $t_{CLCL} = t_{CH} + t_{CL}$.

Figure 41. Asynchronous Reset / Preset

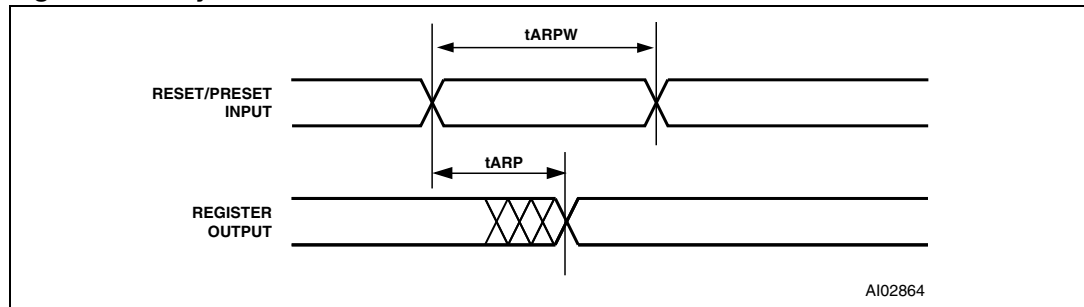

AI02864

Figure 42. Asynchronous Clock mode Timing (product term clock)

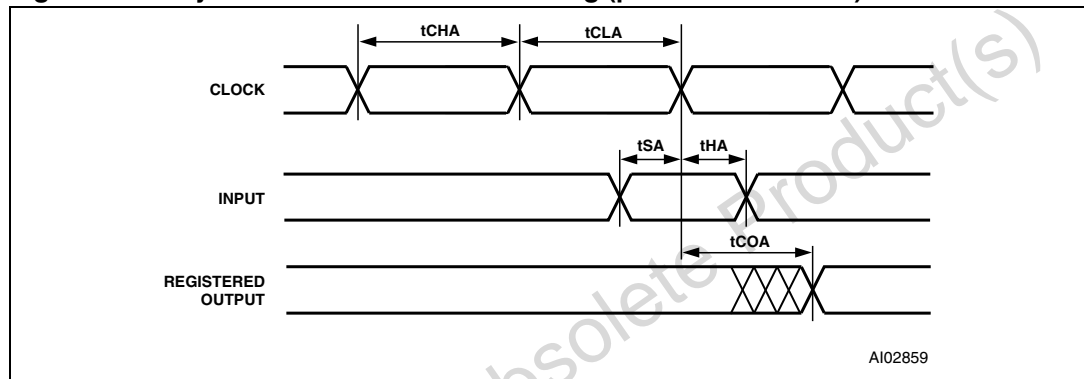

AI02859

Table 52. CPLD macrocell asynchronous clock mode timing (5 V devices)

Symbol	Parameter	Conditions	-70		-90		-15		PT Alloc	Turbo off	Slew rate	Unit
			Min	Max	Min	Max	Min	Max				
f _{MAXA}	Maximum frequency External feedback	1/(t _{SA} +t _{COA})		38.4		26.32		21.27				MHz
	Maximum frequency Internal feedback (f _{CNTA})	1/(t _{SA} +t _{COA} -10)		62.5		35.71		27.78				MHz
	Maximum frequency Pipelined data	1/(t _{CHA} +t _{CLA})		71.4		41.67		35.71				MHz
t _{SA}	Input setup time		7		8		12		+ 2	+ 10		ns
t _{HA}	Input hold time		8		12		14					ns
t _{CHA}	Clock input high time		9		12		15			+ 10		ns
t _{CLA}	Clock input low time		9		12		15			+ 10		ns

Table 52. CPLD macrocell asynchronous clock mode timing (5 V devices) (continued)

Symbol	Parameter	Conditions	-70		-90		-15		PT Alloc	Turbo off	Slew rate	Unit
			Min	Max	Min	Max	Min	Max				
t_{COA}	Clock to output delay			21		30		37		+ 10	- 2	ns
t_{ARDA}	CPLD array delay	Any macrocell		11		16		22	+ 2			ns
t_{MINA}	Minimum clock period	$1/f_{CNTA}$	16		28		39					ns

Table 53. CPLD macrocell Asynchronous clock mode timing (3 V devices)

Symbol	Parameter	Conditions	-12		-15		-20		PT Alloc	Turbo off	Slew rate	Unit
			Min	Max	Min	Max	Min	Max				
f_{MAXA}	Maximum frequency External feedback	$1/(t_{SA}+t_{COA})$		21.7		19.2		16.9				MHz
	Maximum frequency Internal feedback (f_{CNTA})	$1/(t_{SA}+t_{COA}-10)$		27.8		23.8		20.4				MHz
	Maximum frequency Pipelined data	$1/(t_{CHA}+t_{CLA})$		33.3		27		24.4				MHz
t_{SA}	Input setup time		10		12		13		+ 4	+ 20		ns
t_{HA}	Input hold time		12		15		17					ns
t_{CHA}	Clock high time		17		22		25			+ 20		ns
t_{CLA}	Clock low time		13		15		16			+ 20		ns
t_{COA}	Clock to output delay			36		40		46		+ 20	- 6	ns
t_{ARD}	CPLD array delay	Any macrocell		25		29		33	+ 4			ns
t_{MINA}	Minimum clock period	$1/f_{CNTA}$	36		42		49					ns

Figure 43. Input macrocell timing (product term clock)

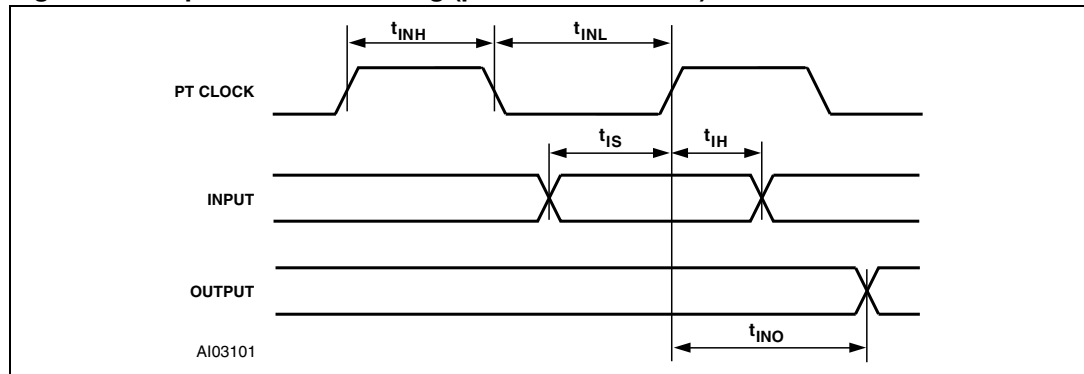

Table 54. Input macrocell timing (5 V devices)

Symbol	Parameter	Conditions	-70		-90		-15		PT Alloc	Turbo off	Unit
			Min	Max	Min	Max	Min	Max			
t _{IS}	Input setup time	(1)	0		0		0				ns
t _{IH}	Input hold time	(1)	15		20		26			+ 10	ns
t _{INH}	NIB input high time	(1)	9		12		18				ns
t _{INL}	NIB input low time	(1)	9		12		18				ns
t _{INO}	NIB input to combinatorial delay	(1)		34		46		59	+ 2	+ 10	ns

1. Inputs from port A, B, and C relative to register/ latch clock from the PLD. ALE/AS latch timings refer to t_{AVLX} and t_{LXAX}.

Table 55. input macrocell timing (3 V devices)

Symbol	Parameter	Conditions	-12		-15		-20		PT Alloc	Turbo off	Unit
			Min	Max	Min	Max	Min	Max			
t _{IS}	Input setup time	(1)	0		0		0				ns
t _{IH}	Input hold time	(1)	25		25		30			+ 20	ns
t _{INH}	NIB input high time	(1)	12		13		15				ns
t _{INL}	NIB input low time	(1)	12		13		15				ns
t _{INO}	NIB input to combinatorial delay	(1)		46		62		70	+ 4	+ 20	ns

1. Inputs from port A, B, and C relative to register/ latch clock from the PLD. ALE latch timings refer to t_{AVLX} and t_{LXAX}.

Figure 44. READ timing

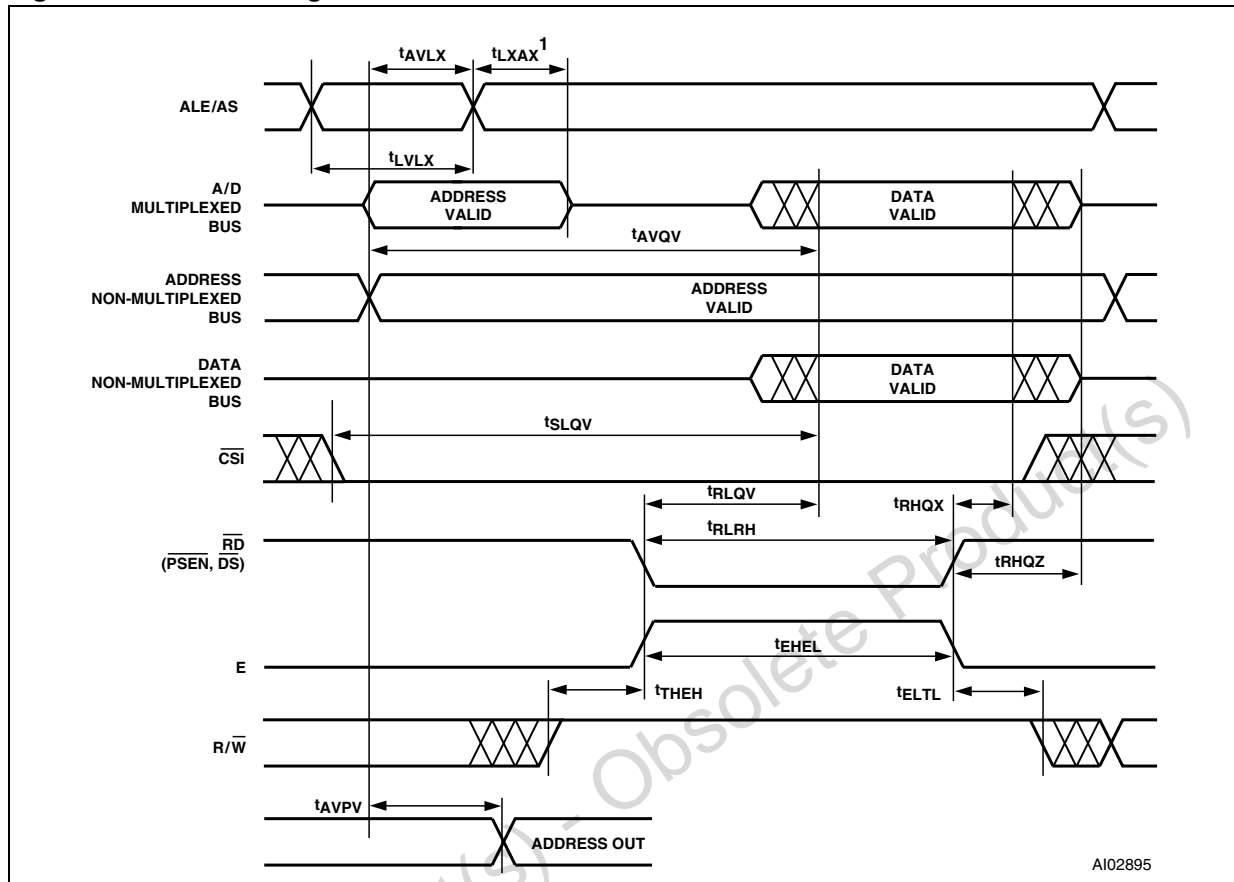

1. t_{AVLX} and t_{LXAX} are not required for 80C251 in Page mode or 80C51XA in Burst mode.

Table 56. READ timing (5 V devices)

Symbol	Parameter	Conditions	-70		-90		-15		Turbo off	Unit
			Min	Max	Min	Max	Min	Max		
t_{LVLX}	ALE or AS pulse width		15		20		28			ns
t_{AVLX}	Address setup time	(1)	4		6		10			ns
t_{LXAX}	Address hold time	(1)	7		8		11			ns
t_{AVQV}	Address valid to data valid	(1)		70		90		150	+ 10	ns
t_{SLQV}	CS valid to data valid			75		100		150		ns
t_{RLQV}	\overline{RD} to data valid 8-bit bus	(2)		24		32		40		ns
	\overline{RD} or \overline{PSEN} to data valid 8-bit bus, 8031, 80251	(3)		31		38		45		ns
t_{RHQX}	\overline{RD} data hold time	(4)	0		0		0			ns
t_{RLRH}	\overline{RD} pulse width	(4)	27		32		38			ns
t_{RHQZ}	\overline{RD} to data high-Z	(4)		20		25		30		ns
t_{EHEL}	E pulse width		27		32		38			ns

Table 56. READ timing (5 V devices) (continued)

Symbol	Parameter	Conditions	-70		-90		-15		Turbo off	Unit
			Min	Max	Min	Max	Min	Max		
t _{THEH}	R/ \overline{W} setup time to Enable		6		10		18			ns
t _{ELTL}	R/ \overline{W} hold time After Enable		0		0		0			ns
t _{AVPV}	Address input valid to Address output delay	(5)		20		25		30		ns

- Any input used to select an internal PSD function.
- \overline{RD} timing has the same timing as \overline{DS} , \overline{LDS} , and \overline{UDS} signals.
- \overline{RD} and \overline{PSEN} have the same timing.
- \overline{RD} timing has the same timing as \overline{DS} , \overline{LDS} , \overline{UDS} , and \overline{PSEN} signals.
- In multiplexed mode, latched addresses generated from ADIO delay to address output on any port.

Table 57. READ timing (3 V devices)

Symbol	Parameter	Conditions	-12		-15		-20		Turbo off	Unit
			Min	Max	Min	Max	Min	Max		
t _{LVLX}	ALE or AS pulse width		26		26		30			ns
t _{AVLX}	Address setup time	(1)	9		10		12			ns
t _{LXAX}	Address hold time	(1)	9		12		14			ns
t _{AVQV}	Address valid to data valid	(1)		120		150		200	+ 20	ns
t _{SLQV}	CS valid to data valid			120		150		200		ns
t _{RLQV}	\overline{RD} to data valid 8-bit bus	(2)		35		35		40		ns
	\overline{RD} or \overline{PSEN} to data valid 8-bit bus, 8031, 80251	(3)		45		50		55		ns
t _{RHQX}	\overline{RD} data hold time	(4)	0		0		0			ns
t _{RLRH}	\overline{RD} pulse width		38		40		45			ns
t _{RHQZ}	\overline{RD} to data high-Z	(4)		38		40		45		ns
t _{EHEL}	E pulse width		40		45		52			ns
t _{THEH}	R/ \overline{W} setup time to enable		15		18		20			ns
t _{ELTL}	R/ \overline{W} hold time after enable		0		0		0			ns
t _{AVPV}	Address input valid to address output delay	(5)		33		35		40		ns

- Any input used to select an internal PSD function.
- \overline{RD} timing has the same timing as \overline{DS} , \overline{LDS} , and \overline{UDS} signals.
- \overline{RD} and \overline{PSEN} have the same timing for 8031.
- \overline{RD} timing has the same timing as \overline{DS} , \overline{LDS} , \overline{UDS} , and \overline{PSEN} signals.
- In multiplexed mode latched address generated from ADIO delay to address output on any port.

Figure 45. WRITE timing

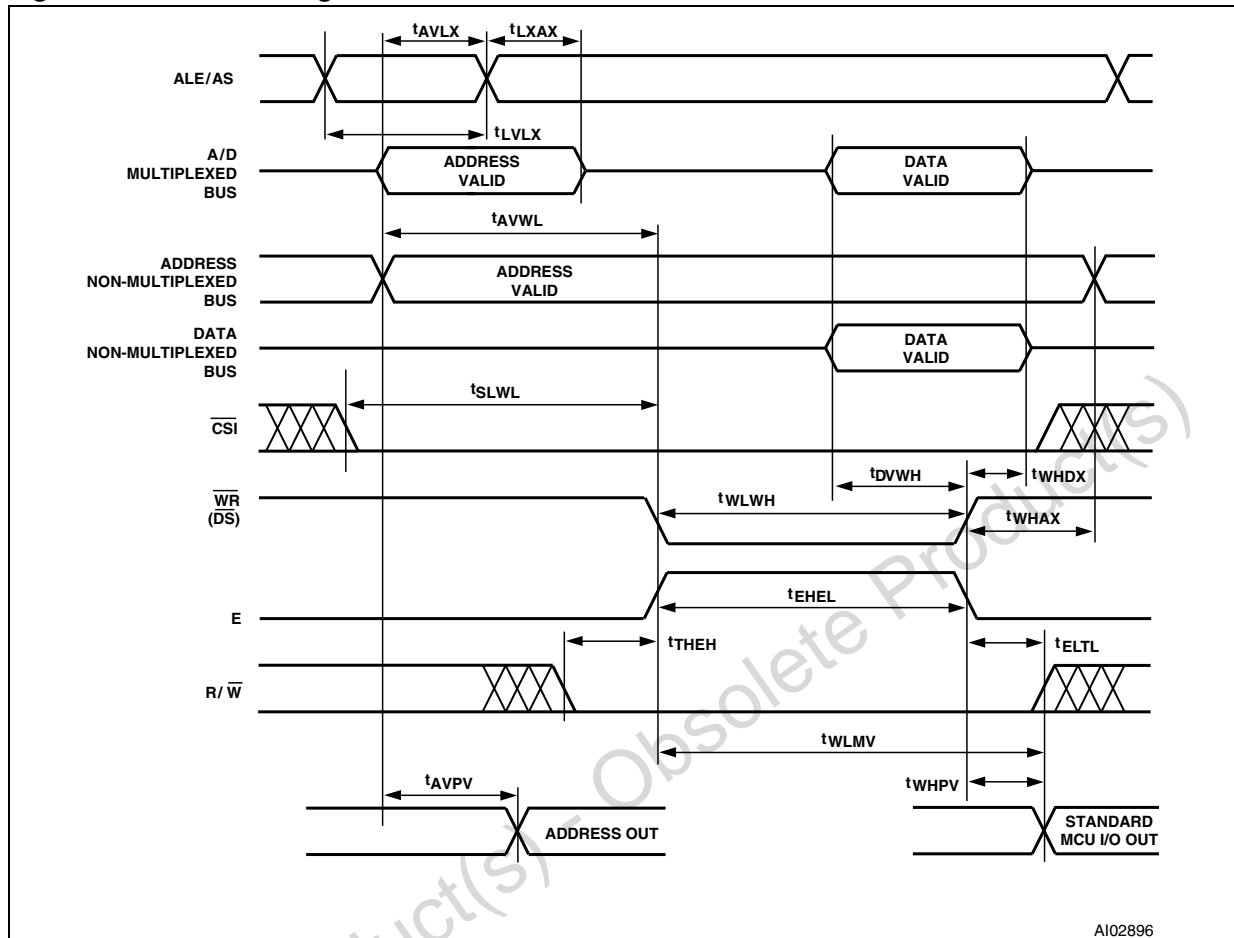

AI02896

Table 58. WRITE timing (5 V devices)

Symbol	Parameter	Conditions	-70		-90		-15		Unit
			Min	Max	Min	Max	Min	Max	
t_{LVLX}	ALE or AS pulse width		15		20		28		ns
t_{AVLX}	Address setup time	(1)	4		6		10		ns
t_{LXAX}	Address hold time	(1)	7		8		11		ns
t_{AVWL}	Address valid to leading edge of \overline{WR}	(1)(2)	8		15		20		ns
t_{SLWL}	\overline{CS} valid to leading edge of \overline{WR}	(2)	12		15		20		ns
t_{DVBH}	\overline{WR} data setup time	(2)	25		35		45		ns
t_{WHDX}	\overline{WR} data hold time	(2)	4		5		5		ns
t_{WLWH}	\overline{WR} pulse width	(2)	31		35		45		ns
t_{WHAX1}	Trailing edge of \overline{WR} to address invalid	(2)	6		8		10		ns
t_{WHAX2}	Trailing edge of \overline{WR} to DPLD address invalid	(2)(3)	0		0		0		ns

Table 58. WRITE timing (5 V devices) (continued)

Symbol	Parameter	Conditions	-70		-90		-15		Unit
			Min	Max	Min	Max	Min	Max	
t_{WHPV}	Trailing edge of \overline{WR} to port output valid using I/O port data register	(2)		27		30		38	ns
t_{DVMV}	Data valid to port output valid using macrocell register Preset/Clear	(2)(4)		42		55		65	ns
t_{AVPV}	Address input valid to address output delay	(5)		20		25		30	ns
t_{WLMV}	\overline{WR} valid to port output valid using macrocell register Preset/Clear	(2)(6)		48		55		65	ns

1. Any input used to select an internal PSD function.
2. \overline{WR} has the same timing as E, \overline{LDS} , \overline{UDS} , \overline{WRL} , and \overline{WRH} signals.
3. t_{WHAX2} is the address hold time for DPLD inputs that are used to generate Sector Select signals for internal PSD memory.
4. Assuming WRITE is active before data becomes valid.
5. In multiplexed mode, latched address generated from ADIO delay to address output on any port.
6. Assuming data is stable before active WRITE signal.

Table 59. WRITE timing (3 V devices)

Symbol	Parameter	Conditions	-12		-15		-20		Unit
			Min	Max	Min	Max	Min	Max	
t_{LVLX}	ALE or AS pulse width		26		26		30		
t_{AVLX}	Address setup time	(1)	9		10		12		ns
t_{LXAX}	Address hold time	(1)	9		12		14		ns
t_{AVWL}	Address valid to Leading Edge of \overline{WR}	(1)(2)	17		20		25		ns
t_{SLWL}	\overline{CS} valid to Leading Edge of \overline{WR}	(2)	17		20		25		ns
t_{DVWH}	\overline{WR} data setup time	(2)	45		45		50		ns
t_{WHDX}	\overline{WR} data hold time	(2)	7		8		10		ns
t_{WLWH}	\overline{WR} pulse width	(2)	46		48		53		ns
t_{WHAX1}	Trailing edge of \overline{WR} to address invalid	(2)	10		12		17		ns
t_{WHAX2}	Trailing edge of \overline{WR} to DPLD address invalid	(2)(3)	0		0		0		ns
t_{WHPV}	Trailing edge of \overline{WR} to port output valid using I/O port data register	(2)		33		35		40	ns
t_{DVMV}	Data valid to port output valid using macrocell register Preset/Clear	(2)(4)		70		70		80	ns

Table 59. WRITE timing (3 V devices) (continued)

Symbol	Parameter	Conditions	-12		-15		-20		Unit
			Min	Max	Min	Max	Min	Max	
t_{AVPV}	Address input valid to address output delay	(5)		33		35		40	ns
t_{WLMV}	\overline{WR} valid to port output valid using macrocell register Preset/Clear	(2)(6)		70		70		80	ns

- Any input used to select an internal PSD function.
- \overline{WR} has the same timing as E, \overline{LDS} , \overline{UDS} , \overline{WRL} , and \overline{WRH} signals.
- t_{WHAX2} is the address hold time for DPLD inputs that are used to generate Sector Select signals for internal PSD memory.
- Assuming WRITE is active before data becomes valid.
- In multiplexed mode, latched address generated from ADIO delay to address output on any port.
- Assuming data is stable before active WRITE signal.

Table 60. Program, WRITE and Erase times (5 V devices)

Symbol	Parameter	Min.	Typ.	Max.	Unit
	Flash Program		8.5		s
	Flash Bulk Erase (pre-programmed) ⁽¹⁾		3	30	s
	Flash Bulk Erase (not pre-programmed)		5		s
t_{WHQV3}	Sector Erase (pre-programmed)		1	30	s
t_{WHQV2}	Sector Erase (not pre-programmed)		2.2		s
t_{WHQV1}	Byte Program		14	1200	μ s
	Program/Erase cycles (per sector)	100,000			cycles
t_{WHWLO}	Sector Erase timeout		100		μ s
t_{Q7VQV}	DQ7 valid to output (DQ7-DQ0) valid (data polling) ⁽²⁾			30	ns

- The whole memory is programmed to 00h before erase.
- The polling status, DQ7, is valid t_{Q7VQV} time units before the data byte, DQ0-DQ7, is valid for reading.

Table 61. Program, WRITE and Erase times (3 V devices)

Symbol	Parameter	Min.	Typ.	Max.	Unit
	Flash Program		8.5		s
	Flash Bulk Erase (pre-programmed) ⁽¹⁾		3	30	s
	Flash Bulk Erase (not pre-programmed)		5		s
t_{WHQV3}	Sector Erase (pre-programmed)		1	30	s
t_{WHQV2}	Sector Erase (not pre-programmed)		2.2		s
t_{WHQV1}	Byte Program		14	1200	μ s
	Program / Erase Cycles (per sector)	100,000			cycles
t_{WHWLO}	Sector Erase timeout		100		μ s
t_{Q7VQV}	DQ7 valid to Output (DQ7-DQ0) valid (data polling) ⁽²⁾			30	ns

1. The whole memory is programmed to 00h before erase.
2. The polling status, DQ7, is valid tQ7VQV time units before the data byte, DQ0-DQ7, is valid for reading.

Figure 46. Peripheral I/O READ timing

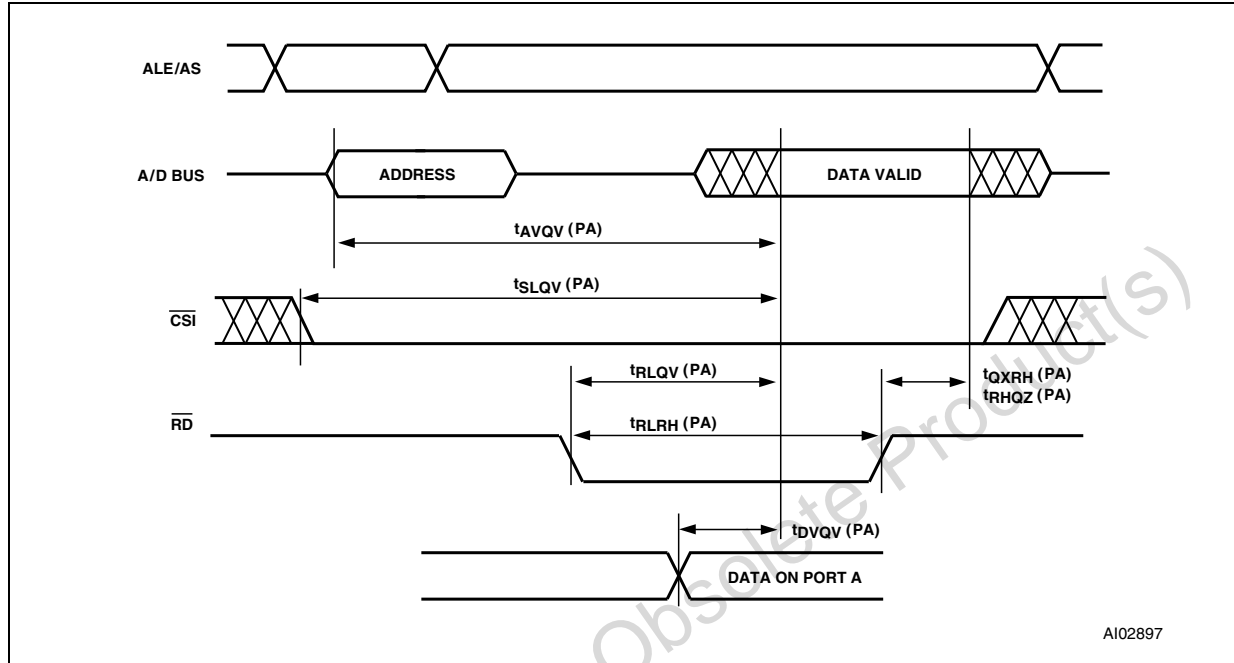

Table 62. Port A Peripheral Data mode READ timing (5 V devices)

Symbol	Parameter	Conditions	-70		-90		-15		Turbo off	Unit
			Min	Max	Min	Max	Min	Max		
$t_{AVQV-PA}$	Address valid to data valid	(1)		37		39		45	+ 10	ns
$t_{SLQV-PA}$	CSi valid to data valid			27		35		45	+ 10	ns
$t_{RLQV-PA}$	RD to data valid	(2)(3)		21		32		40		ns
	RD to data valid 8031 mode			32		38		45		ns
$t_{DVQV-PA}$	Data In to data out valid			22		30		38		ns
$t_{QLRH-PA}$	RD data hold time		0		0		0			ns
$t_{RLRH-PA}$	RD pulse width	(2)	27		32		38			ns
$t_{RHQZ-PA}$	RD to data high-Z	(2)		23		25		30		ns

1. Any input used to select port A Data Peripheral mode.
2. RD has the same timing as DS, LDS, UDS, and PSEN (in 8031 combined mode).
3. Data is already stable on port A.

Table 63. Port A Peripheral Data mode READ timing (3V devices)

Symbol	Parameter	Conditions	-12		-15		-20		Turbo off	Unit
			Min	Max	Min	Max	Min	Max		
$t_{AVQV-PA}$	Address valid to data valid	(1)		50		50		50	+ 20	ns
$t_{SLQV-PA}$	\overline{CS} valid to data valid			37		45		50	+ 20	ns
$t_{RLQV-PA}$	\overline{RD} to data valid	(2)(3)		37		40		45		ns
	\overline{RD} to data valid 8031 mode			45		45		50		ns
$t_{DVQV-PA}$	Data In to data Out valid			38		40		45		ns
$t_{QXRH-PA}$	\overline{RD} data hold time		0		0		0			ns
$t_{RLRH-PA}$	\overline{RD} pulse width	(2)	36		36		46			ns
$t_{RHQZ-PA}$	\overline{RD} to data high-Z	(2)		36		40		45		ns

- Any input used to select port A Data Peripheral mode.
- \overline{RD} has the same timing as \overline{DS} , \overline{LDS} , \overline{UDS} , and \overline{PSEN} (in 8031 combined mode).
- Data is already stable on port A.

Figure 47. Peripheral I/O WRITE timing

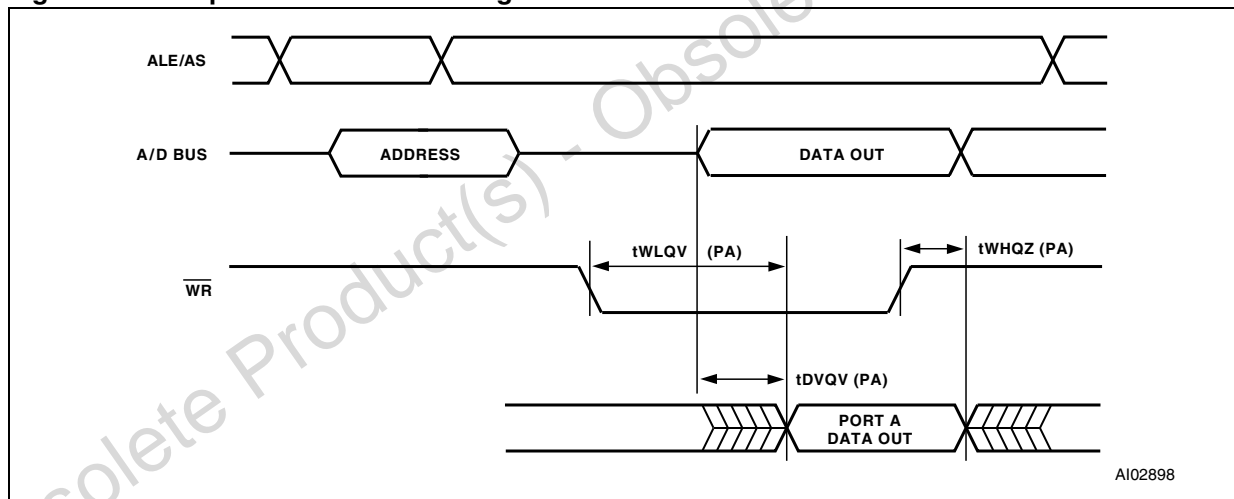

Table 64. Port A Peripheral Data mode WRITE timing (5 V devices)

Symbol	Parameter	Conditions	-70		-90		-15		Unit
			Min	Max	Min	Max	Min	Max	
$t_{WLQV-PA}$	\overline{WR} to data propagation delay	(1)		25		35		40	ns
$t_{DVQV-PA}$	Data to port A data propagation delay	(2)		22		30		38	ns
$t_{WHQZ-PA}$	\overline{WR} invalid to port A tri-state	(1)		20		25		33	ns

- \overline{WR} has the same timing as the \overline{E} , \overline{LDS} , \overline{UDS} , \overline{WRL} , and \overline{WRH} signals.
- Data stable on ADIO pins to data on port A.

Table 65. Port A Peripheral Data mode WRITE timing (3 V devices)

Symbol	Parameter	Conditions	-12		-15		-20		Unit
			Min	Max	Min	Max	Min	Max	
$t_{WLQV-PA}$	\overline{WR} to data propagation delay	(1)		42		45		55	ns
$t_{DVQV-PA}$	Data to port A data propagation delay	(2)		38		40		45	ns
$t_{WHQZ-PA}$	\overline{WR} invalid to port A tri-state	(1)		33		33		35	ns

- \overline{WR} has the same timing as the \overline{E} , \overline{LDS} , \overline{UDS} , \overline{WRL} , and \overline{WRH} signals.
- Data stable on ADIO pins to data on port A.

Figure 48. Reset (\overline{RESET}) timing

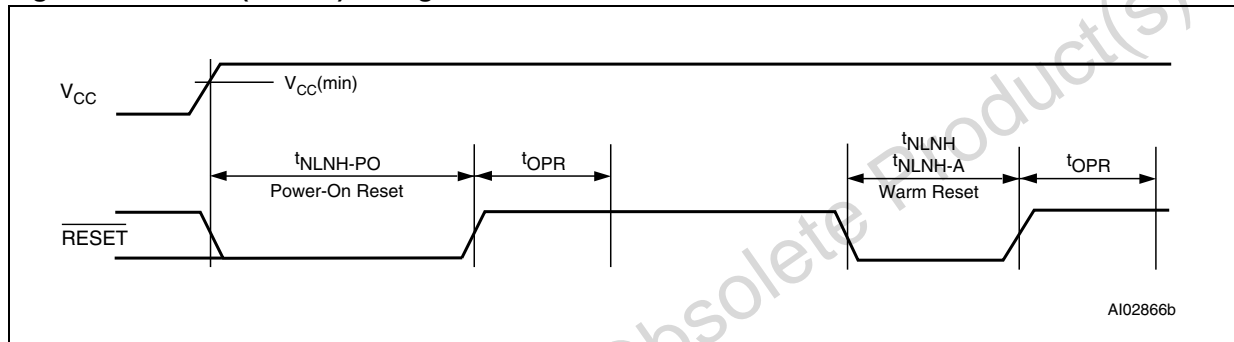

Table 66. Reset (\overline{RESET}) timing (5 V devices)

Symbol	Parameter	Conditions	Min	Max	Unit
t_{NLNH}	\overline{RESET} active low time ⁽¹⁾		150		ns
$t_{NLNH-PO}$	Power-on Reset active low time		1		ms
t_{NLNH-A}	Warm Reset (on the PSD834Fx) ⁽²⁾		25		μ s
t_{OPR}	\overline{RESET} high to operational device			120	ns

- Reset (\overline{RESET}) does not reset Flash memory program or erase cycles.
- Warm reset aborts Flash memory program or erase cycles, and puts the device in READ mode.

Table 67. Reset (\overline{RESET}) timing (3 V devices)

Symbol	Parameter	Conditions	Min	Max	Unit
t_{NLNH}	\overline{RESET} active low time ⁽¹⁾		300		ns
$t_{NLNH-PO}$	Power-on Reset active low time		1		ms
t_{NLNH-A}	Warm Reset (on the PSD834Fx) ⁽²⁾		25		μ s
t_{OPR}	\overline{RESET} high to operational device			300	ns

- Reset (\overline{RESET}) does not reset Flash memory program or erase cycles.
- Warm reset aborts Flash memory program or erase cycles, and puts the device in READ mode.

Figure 49. ISC timing

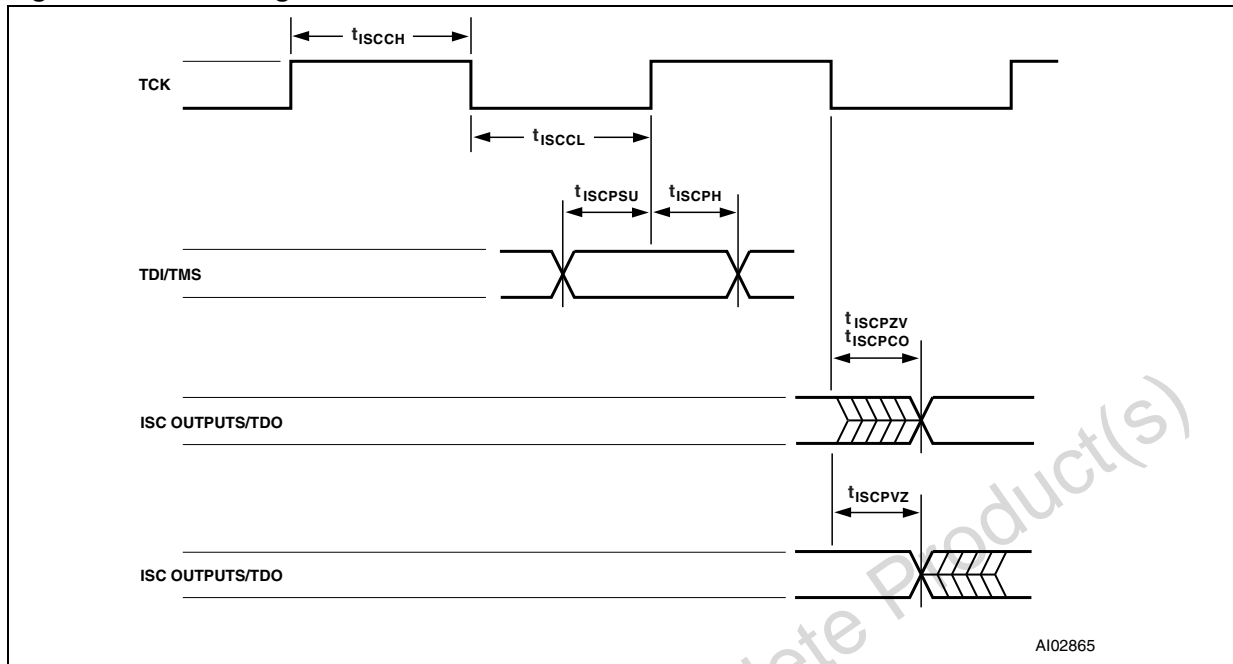

A102865

Table 68. ISC timing (5 V devices)

Symbol	Parameter	Conditions	-70		-90		-15		Unit
			Min	Max	Min	Max	Min	Max	
t_{ISCCF}	Clock (TCK, PC1) frequency (except for PLD)	(1)		20		18		14	MHz
t_{ISCCH}	Clock (TCK, PC1) high time (except for PLD)	(1)	23		26		31		ns
t_{ISCCL}	Clock (TCK, PC1) low time (except for PLD)	(1)	23		26		31		ns
t_{ISCCFP}	Clock (TCK, PC1) frequency (PLD only)	(2)		2		2		2	MHz
t_{ISCCHP}	Clock (TCK, PC1) high time (PLD only)	(2)	240		240		240		ns
t_{ISCCLP}	Clock (TCK, PC1) low time (PLD only)	(2)	240		240		240		ns
t_{ISCPSU}	ISC port setup time		7		8		10		ns
t_{ISCPH}	ISC port hold up time		5		5		5		ns
t_{ISCPCO}	ISC port clock to output			21		23		25	ns
t_{ISCPZV}	ISC port high-impedance to valid output			21		23		25	ns
t_{ISCPVZ}	ISC port valid output to high-impedance			21		23		25	ns

1. For non-PLD Programming, Erase or in ISC by-pass mode.

2. For program or erase PLD only.

Table 69. ISC timing (3 V devices)

Symbol	Parameter	Conditions	-12		-15		-20		Unit
			Min	Max	Min	Max	Min	Max	
t_{ISCCF}	Clock (TCK, PC1) frequency (except for PLD)	(1)		12		10		9	MHz
t_{ISCCH}	Clock (TCK, PC1) high time (except for PLD)	(1)	40		45		51		ns
t_{ISCCL}	Clock (TCK, PC1) low time (except for PLD)	(1)	40		45		51		ns
t_{ISCCFP}	Clock (TCK, PC1) frequency (PLD only)	(2)		2		2		2	MHz
t_{ISCCHP}	Clock (TCK, PC1) high time (PLD only)	(2)	240		240		240		ns
t_{ISCCLP}	Clock (TCK, PC1) low time (PLD only)	(2)	240		240		240		ns
t_{ISCPsu}	ISC port setup time		12		13		15		ns
t_{ISCPH}	ISC port hold up time		5		5		5		ns
t_{ISPCO}	ISC port clock to output			30		36		40	ns
t_{ISCPZV}	ISC port high-Impedance to valid Output			30		36		40	ns
t_{ISCPVZ}	ISC port valid Output to high-Impedance			30		36		40	ns

1. For non-PLD Programming, Erase or in ISC by-pass mode.
2. For program or erase PLD only.

Table 70. Power-down timing (5 V devices)

Symbol	Parameter	Conditions	-70		-90		-15		Unit
			Min	Max	Min	Max	Min	Max	
t_{LVDV}	ALE access time from Power-down			80		90		150	ns
t_{CLWH}	Maximum delay from APD Enable to Internal PDN valid signal	Using CLKIN (PD1)	$15 * t_{CLCL}^{(1)}$						μs

1. t_{CLCL} is the period of CLKIN (PD1).

Table 71. Power-down timing (3 V devices)

Symbol	Parameter	Conditions	-12		-15		-20		Unit
			Min	Max	Min	Max	Min	Max	
t_{LVDV}	ALE access time from Power-down			145		150		200	ns
t_{CLWH}	Maximum Delay from APD Enable to Internal PDN valid Signal	Using CLKIN (PD1)	$15 * t_{CLCL}^{(1)}$						μs

1. t_{CLCL} is the period of CLKIN (PD1).

23 Package mechanical

In order to meet environmental requirements, ST offers this device in different grades of ECOPACK® packages, depending on their level of environmental compliance. ECOPACK® specifications, grade definitions and product status are available at: www.st.com. ECOPACK® is an ST trademark.

Obsolete Product(s) - Obsolete Product(s)

Figure 50. PQFP52 - 52-pin plastic quad flat package mechanical drawing

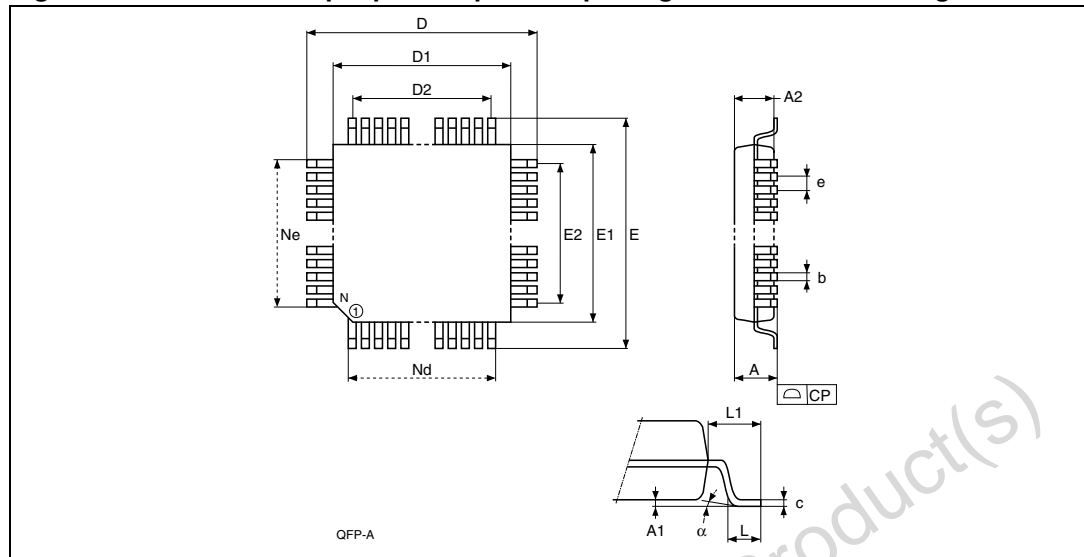

1. Drawing is not to scale.

Table 72. PQFP52 - 52-pin plastic quad flat package mechanical dimensions

Symbol	mm			inches		
	Typ.	Min.	Max.	Typ.	Min.	Max.
A			2.350			0.0930
A1			0.250			0.0100
A2	2.000	1.800	2.100	0.0790	0.0770	0.0830
b		0.220	0.380		0.0090	0.0150
c		0.110	0.230		0.0040	0.0090
D	13.200	13.150	13.250	0.5200	0.5180	0.5220
D1	10.000	9.950	10.050	0.3940	0.3920	0.3960
D2	7.800	-	-	0.3070	-	-
E	13.200	13.150	13.250	0.5200	0.5180	0.5220
E1	10.000	9.950	10.050	0.3940	0.3920	0.3960
E2	7.800	-	-	0.3070	-	-
e	0.650	-	-	0.0260		
L	0.880	0.730	1.030	0.0350	0.0290	0.0410
L1	1.600	-	-	0.0630		
alpha		0°	7°		0°	7°
N	52			52		
Nd	13			13		
Ne	13			13		
CP			0.100			0.0040

Figure 51. PLCC52 - 52-lead plastic lead chip carrier package mechanical drawing

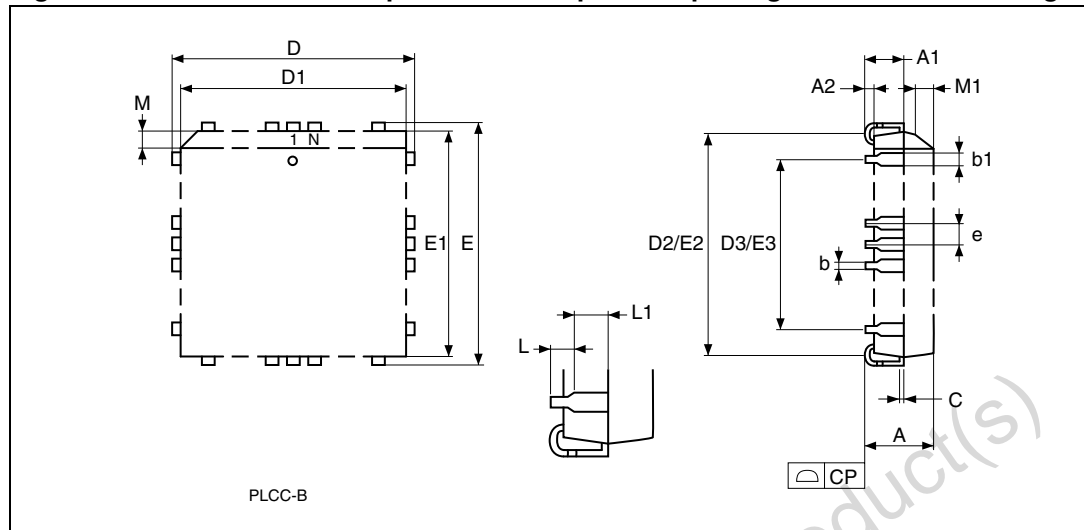

1. Drawing is not to scale.

Table 73. PLCC52-52-lead plastic lead chip carrier mechanical dimensions

Symbol	mm			inches		
	Typ.	Min.	Max.	Typ.	Min.	Max.
A		4.190	4.570		0.1650	0.1800
A1		2.540	2.790		0.1000	0.1100
A2		–	0.910		–	0.0360
B		0.330	0.530		0.0130	0.0210
B1		0.660	0.810		0.0260	0.0320
C		0.2460	0.2610		0.0097	0.0103
D		19.940	20.190		0.7850	0.7950
D1		19.050	19.150		0.7500	0.7540
D2		17.530	18.540		0.6900	0.7300
E		19.940	20.190		0.7850	0.7950
E1		19.050	19.150		0.7500	0.7540
E2		17.530	18.540		0.6900	0.7300
e	1.270	–	–	0.050	–	–
R	0.890	–	–	0.035	–	–
N		52			52	
Nd		13			13	
Ne		13			13	

Figure 52. TQFP64 - 64-lead thin quad flatpack, package outline

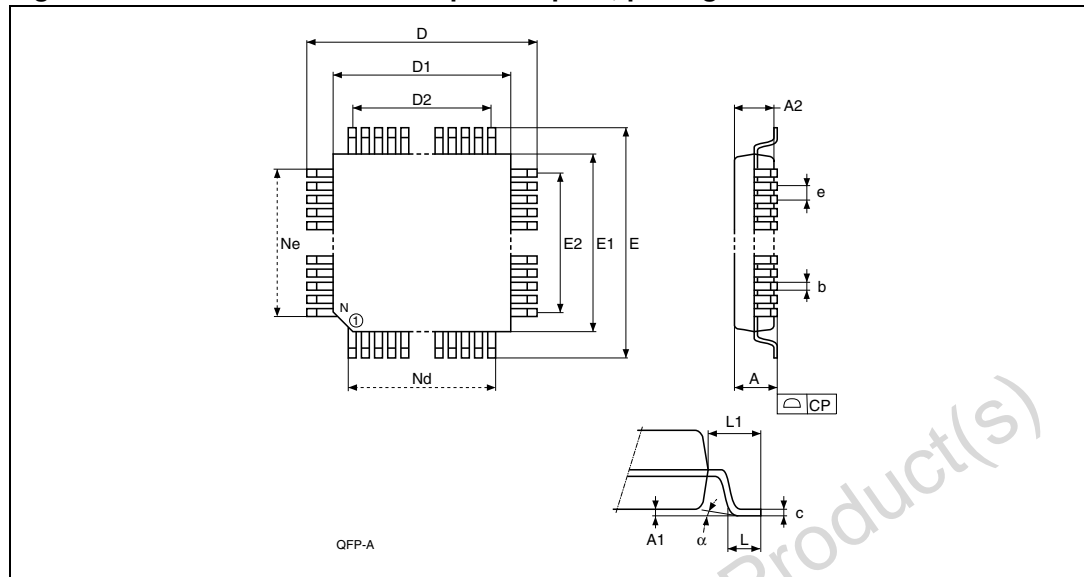

1. Drawing is not to scale.

Table 74. TQFP64 - 64-lead thin quad flatpack, package mechanical data

Symb.	mm			inches		
	Typ.	Min.	Max.	Typ.	Min.	Max.
A		1.420	1.540		0.0560	0.0610
A1	0.100	0.070	0.140	0.0040	0.0030	0.0050
A2	1.400	1.360	1.440	0.0550	0.0540	0.0570
a	3.5°	0.0°	7.0°	3.5°	0.0°	7.0°
b	0.350	0.330	0.380	0.0140	0.0130	0.0150
c			0.170			0.006
D	16.000	15.900	16.100	0.6300	0.6260	0.6340
D1	14.000	13.980	14.030	0.5510	0.5500	0.5520
D2	12.000	11.950	12.050	0.4720	0.4700	0.4740
E	16.000	15.900	16.100	0.6300	0.6260	0.6340
E1	14.000	13.980	14.030	0.5510	0.5500	0.5520
E2	12.000	11.950	12.050	0.4720	0.4700	0.4740
e	0.800	0.750	0.850	0.0310	0.0300	0.0330
L	0.600	0.450	0.750	0.0240	0.0180	0.0300
L1	1.000	0.940	1.060	0.0390	0.0370	0.0420
CP	0.100			0.0040		
N	64			64		
Nd	16			16		
Ne	16			16		

24 Part numbering

Table 75. Ordering information scheme

Example:	PSD8	1	3	F	2	V	A	- 15	J	1	T
Device Type											
PSD8 = 8-bit PSD with register Logic											
SRAM Capacity											
1 = 16 Kbit											
3 = 64 Kbit											
5 = 256 Kbit											
Flash Memory Capacity											
3 = 1 Mbit (128K x 8)											
4 = 2 Mbit (256K x 8)											
2nd Flash Memory											
2 = 256 Kbit Flash memory + SRAM											
3 = SRAM but no Flash memory											
4 = 256 Kbit Flash memory but no SRAM											
5 = no Flash memory + no SRAM											
Operating voltage											
blank = V _{CC} = 4.5 to 5.5V											
V = V _{CC} = 3.0 to 3.6V											
Silicon Revision											
A = Revision A											
Speed											
70 = 70ns											
90 = 90ns											
12 = 120ns											
15 = 150ns											
20 = 200ns											
Package											
J = ECOPACK-compliant PLCC52											
M = ECOPACK-compliant PQFP52											
U = ECOPACK-compliant TQFP64											
Temperature Range											
blank = 0 to 70°C (commercial)											
I = -40 to 85°C (industrial)											
Option											
T = Tape & Reel Packing											

For a list of available options (e.g., speed, package) or for further information on any aspect of this device, please contact your nearest ST Sales Office.

Appendix A PQFP52 pin assignments

Table 76. PQFP52 connections (see *Features*)

Pin number	Pin assignments
1	PD2
2	PD1
3	PD0
4	PC7
5	PC6
6	PC5
7	PC4
8	V _{CC}
9	GND
10	PC3
11	PC2
12	PC1
13	PC0
14	PA7
15	PA6
16	PA5
17	PA4
18	PA3
19	GND
20	PA2
21	PA1
22	PA0
23	AD0
24	AD1
25	AD2
26	AD3
27	AD4
28	AD5
29	AD6
30	AD7
31	V _{CC}
32	AD8

Table 76. PQFP52 connections (see *Features*) (continued)

Pin number	Pin assignments
33	AD9
34	AD10
35	AD11
36	AD12
37	AD13
38	AD14
39	AD15
40	CNTL0
41	RESET
42	CNTL2
43	CNTL1
44	PB7
45	PB6
46	GND
47	PB5
48	PB4
49	PB3
50	PB2
51	PB1
52	PB0

Appendix B PLCC52 pin assignments

Table 77. PLCC52 connections (see *Features*)

Pin number	Pin assignments
1	GND
2	PB5
3	PB4
4	PB3
5	PB2
6	PB1
7	PB0
8	PD2
9	PD1
10	PD0
11	PC7
12	PC6
13	PC5
14	PC4
15	V _{CC}
16	GND
17	PC3
18	PC2
19	PC1
20	PC0
21	PA7
22	PA6
23	PA5
24	PA4
25	PA3
26	GND
27	PA2
28	PA1
29	PA0
30	AD0
31	AD1
32	AD2

Table 77. PLCC52 connections (see [Features](#)) (continued)

Pin number	Pin assignments
33	AD3
34	AD4
35	AD5
36	AD6
37	AD7
38	V _{CC}
39	AD8
40	AD9
41	AD10
42	AD11
43	AD12
44	AD13
45	AD14
46	AD15
47	CNTL0
48	RESET
49	CNTL2
50	CNTL1
51	PB7
52	PB6

Appendix C TQFP64 pin assignments

Table 78. TQFP64 connections (see *Features*)

Pin number	Pin assignments
1	PD2
2	PD1
3	PD0
4	PC7
5	PC6
6	PC5
7	V _{CC}
8	V _{CC}
9	V _{CC}
10	GND
11	GND
12	PC3
13	PC2
14	PC1
15	PC0
16	NC
17	NC
18	NC
19	PA7
20	PA6
21	PA5
22	PA4
23	PA3
24	GND
25	GND
26	PA2
27	PA1
28	PA0
29	AD0
30	AD1
31	N/D
32	AD2

Table 78. TQFP64 connections (see *Features*) (continued)

Pin number	Pin assignments
33	AD3
34	AD4
35	AD5
36	AD6
37	AD7
38	V _{CC}
39	V _{CC}
40	AD8
41	AD9
42	AD10
43	AD11
44	AD12
45	AD13
46	AD14
47	AD15
48	CNTL0
49	NC
50	RESET
51	CNTL2
52	CNTL1
53	PB7
54	PB6
55	GND
56	GND
57	PB5
58	PB4
59	PB3
60	PB2
61	PB1
62	PB0
63	NC
64	NC

Revision history

Table 79. Document revision history

Date	Revision	Changes
15-Oct-99	1.0	Initial release as a WSI document
27-Oct-00	1.1	Port A Peripheral Data mode Read Timing, changed to 50
30-Nov-00	1.2	PSD85xF2 added
23-Oct-01	2.0	Document rewritten using the ST template
07-Apr-03	3.0	v2.2 Template applied; voltage correction (Table 75)
12-Jun-03	3.1	Fix errors in PQFQ52 Connections
02-Oct-03	3.2	Correct Instructions (Table 10); update disclaimer, Title for EDOCS application
17-Nov-03	3.3	Correct package references (Features)
04-Jun-04	4.0	Reformatted (adjust RPN list); added Table 9 ; added 'U' package (64-pin) (Features , Figure 3 , Figure 52 , Table 74 , Table 75 , Table 78); 5V split from original
05-Jan-06	5.0	Added Silicon Revision A into part numbering scheme. See Table 75
13-Feb-2009	6	Document reformatted. Removed root part number PSD813F3. SRAM standby mode removed. Backup battery feature removed. All products are delivered in ECOPACK-compliant packages. Section 23: Package mechanical updated. Minor text modifications.
05-May-2009	7	Corrected pin 7 of TQFP64 package in Figure 3: TQFP64 connections .

Please Read Carefully:

Information in this document is provided solely in connection with ST products. STMicroelectronics NV and its subsidiaries ("ST") reserve the right to make changes, corrections, modifications or improvements, to this document, and the products and services described herein at any time, without notice.

All ST products are sold pursuant to ST's terms and conditions of sale.

Purchasers are solely responsible for the choice, selection and use of the ST products and services described herein, and ST assumes no liability whatsoever relating to the choice, selection or use of the ST products and services described herein.

No license, express or implied, by estoppel or otherwise, to any intellectual property rights is granted under this document. If any part of this document refers to any third party products or services it shall not be deemed a license grant by ST for the use of such third party products or services, or any intellectual property contained therein or considered as a warranty covering the use in any manner whatsoever of such third party products or services or any intellectual property contained therein.

UNLESS OTHERWISE SET FORTH IN ST'S TERMS AND CONDITIONS OF SALE ST DISCLAIMS ANY EXPRESS OR IMPLIED WARRANTY WITH RESPECT TO THE USE AND/OR SALE OF ST PRODUCTS INCLUDING WITHOUT LIMITATION IMPLIED WARRANTIES OF MERCHANTABILITY, FITNESS FOR A PARTICULAR PURPOSE (AND THEIR EQUIVALENTS UNDER THE LAWS OF ANY JURISDICTION), OR INFRINGEMENT OF ANY PATENT, COPYRIGHT OR OTHER INTELLECTUAL PROPERTY RIGHT.

UNLESS EXPRESSLY APPROVED IN WRITING BY AN AUTHORIZED ST REPRESENTATIVE, ST PRODUCTS ARE NOT RECOMMENDED, AUTHORIZED OR WARRANTED FOR USE IN MILITARY, AIR CRAFT, SPACE, LIFE SAVING, OR LIFE SUSTAINING APPLICATIONS, NOR IN PRODUCTS OR SYSTEMS WHERE FAILURE OR MALFUNCTION MAY RESULT IN PERSONAL INJURY, DEATH, OR SEVERE PROPERTY OR ENVIRONMENTAL DAMAGE. ST PRODUCTS WHICH ARE NOT SPECIFIED AS "AUTOMOTIVE GRADE" MAY ONLY BE USED IN AUTOMOTIVE APPLICATIONS AT USER'S OWN RISK.

Resale of ST products with provisions different from the statements and/or technical features set forth in this document shall immediately void any warranty granted by ST for the ST product or service described herein and shall not create or extend in any manner whatsoever, any liability of ST.

ST and the ST logo are trademarks or registered trademarks of ST in various countries.

Information in this document supersedes and replaces all information previously supplied.

The ST logo is a registered trademark of STMicroelectronics. All other names are the property of their respective owners.

© 2009 STMicroelectronics - All rights reserved



STMicroelectronics group of companies

Australia - Belgium - Brazil - Canada - China - Czech Republic - Finland - France - Germany - Hong Kong - India - Israel - Italy - Japan - Malaysia - Malta - Morocco - Philippines - Singapore - Spain - Sweden - Switzerland - United Kingdom - United States of America



www.st.com

Looking for pricing, stock, or lifecycle information?

Click below to explore more details on WIN SOURCE:

-  [View PSD834F2-90JI on WIN SOURCE](#)
-  [STMicroelectronics](#) Information

Optimize Your Supply Chain with WIN SOURCE Solutions

-  Global Sourcing Solution
-  Obsolete Management
-  Cost Control Management
-  Shortage Management
-  Alternative Solution
-  Excess Inventory Management