

UCS1002-1

Programmable USB Port Power Controller with Charger Emulation

PRODUCT FEATURES

Datasheet

General Description

The UCS1002 provides a USB port power switch for precise control of up to 2.5 amperes continuous current with over-current limit (OCL), dynamic thermal management, latch or auto-recovery (low test current) fault handling, selectable active low or high enable, under- and over-voltage lockout, back-drive protection, and back-voltage protection.

Split supply support for VS and VDD is an option for low power in system standby states. This gives battery operated applications, like notebook PCs, the ability to detect attachments from a sleep or off state. After the Attach Detection is flagged, the system can decide to wake up and/or provide charging.

In addition to power switching and current limiting modes, the UCS1002 will automatically charge a wide variety of portable devices, including USB-IF BC1.2, YD/T-1591 (2009), most Apple® and RIM®, and many others. Nine preloaded charger emulation profiles maximize compatibility coverage of peripheral devices.

As well, a customizable charger emulation profile is available to accommodate unique existing and future portable device handshaking / signature requirements. This custom profile uses a unique stimulus and response method referenced below.*

The UCS1002 also provides current monitoring to allow intelligent management of system power and a Battery Full option for controlled delivery of current regardless of the host power state. This is especially important for battery operated applications that want to provide power in a standby and/or off state but do not want to drain the battery excessively.

The UCS1002 is available in a 20-pin QFN 4 mm x 4 mm package.

Applications

- Notebook and Netbook Computers
- Tablets and E-book readers
- Desktops and Monitors
- Docking Stations and Printers
- AC-DC wall adapters

Features

- Port power switch with two current limit behaviors
 - 2.9 V to 5.5 V source voltage range
 - Up to 2.5 A current with 55 mΩ On Resistance
 - Over-current trip or constant current limiting
 - Soft turn-on circuitry
 - Programmable current limit
 - Dynamic thermal management
 - Under- and over-voltage lockout
 - Back-drive, back-voltage protection
 - Latch or auto-recovery (low test current) fault handling
 - Selectable active high or low power switch enable
 - BC1.2 VBUS discharge port renegotiation function
- Selectable / automatic cycling of USB data line charger emulation profiles
 - Customizable emulation profile uses a unique stimulus and response method useful for future profiles*
 - Supports charger emulation
 - Allows for active cables
 - USB-IF BC1.2 charging downstream port (CDP) & dedicated charging port (DCP) modes, YD/T-1591, and most Apple and RIM protocols standard; others as defined via the SMBus 2.0 / I²C®
 - USB 2.0 compliant high-speed data switch (in Pass-through and CDP modes)
 - Nine preloaded charger emulation profiles for maximum compatibility coverage of peripheral devices
 - One custom programmable charger emulation profile for portable device support for fully host controlled charger emulation
- Fault Alert open-drain output
- Self-contained current monitoring
- Low power Attach Detection and open-drain A_DET# pin
- Ultra low power Sleep state
- Optional split supply support for VBUS and VDD for low power in system standby states
- Wake on Attach USB
- SMBus 2.0 / I²C communications
 - Supports Block Write and Read
 - Multiple SMBus addresses
- Wide operating temperature range: -40 °C to +85 °C
- IEC61000-4-2 8 / 15 kV ESD immunity
- UL recognized and EN/IEC 60950-1 (CB) certified

* Unique technology covered under the following US patents pending: 13/109,446; 13/149,529; 13/173,287; 13/233,949; 13/157,282; 12/978,371; 13/232,965.

Block Diagram

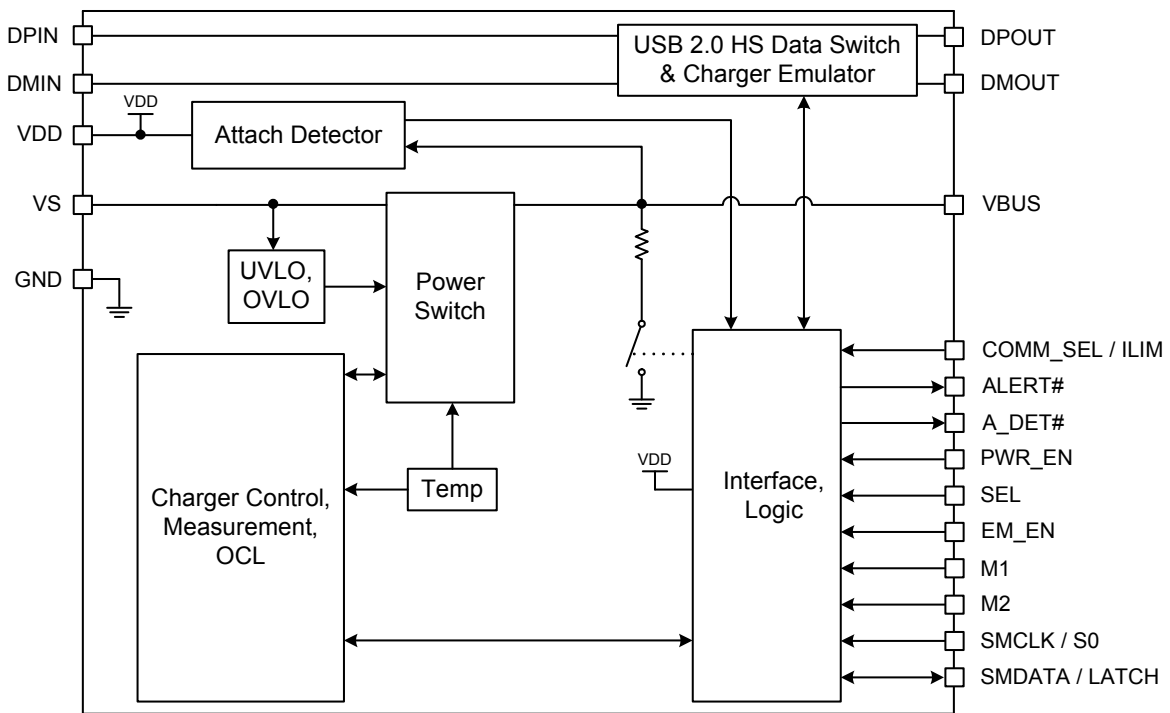

ORDERING INFORMATION:

ORDERING NUMBER	PACKAGE	FEATURES
UCS1002-1-BP-TR	20 pin QFN 4mm x 4mm (RoHS compliant)	USB Port Power Controller with Charger Emulation, 10W Emulation support, Attachment Detection, Current Monitoring, Current Rationing, and Programmable SMBus address

REEL SIZE IS 4,000 PIECES

This product meets the halogen maximum concentration values per IEC61249-2-21

For RoHS compliance and environmental information, please visit www.smSC.com/rohs

Please contact your SMSC sales representative for additional documentation related to this product such as application notes, anomaly sheets, and design guidelines.

Copyright © 2013 SMSC or its subsidiaries. All rights reserved.

Circuit diagrams and other information relating to SMSC products are included as a means of illustrating typical applications. Consequently, complete information sufficient for construction purposes is not necessarily given. Although the information has been checked and is believed to be accurate, no responsibility is assumed for inaccuracies. SMSC reserves the right to make changes to specifications and product descriptions at any time without notice. Contact your local SMSC sales office to obtain the latest specifications before placing your product order. The provision of this information does not convey to the purchaser of the described semiconductor devices any licenses under any patent rights or other intellectual property rights of SMSC or others. All sales are expressly conditional on your agreement to the terms and conditions of the most recently dated version of SMSC's standard Terms of Sale Agreement dated before the date of your order (the "Terms of Sale Agreement"). The product may contain design defects or errors known as anomalies which may cause the product's functions to deviate from published specifications. Anomaly sheets are available upon request. SMSC products are not designed, intended, authorized or warranted for use in any life support or other application where product failure could cause or contribute to personal injury or severe property damage. Any and all such uses without prior written approval of an Officer of SMSC and further testing and/or modification will be fully at the risk of the customer. Copies of this document or other SMSC literature, as well as the Terms of Sale Agreement, may be obtained by visiting SMSC's website at <http://www.smSC.com>. SMSC is a registered trademark of Standard Microsystems Corporation ("SMSC"). Product names and company names are the trademarks of their respective holders.

The Microchip name and logo, and the Microchip logo are registered trademarks of Microchip Technology Incorporated in the U.S.A. and other countries.

SMSC DISCLAIMS AND EXCLUDES ANY AND ALL WARRANTIES, INCLUDING WITHOUT LIMITATION ANY AND ALL IMPLIED WARRANTIES OF MERCHANTABILITY, FITNESS FOR A PARTICULAR PURPOSE, TITLE, AND AGAINST INFRINGEMENT AND THE LIKE, AND ANY AND ALL WARRANTIES ARISING FROM ANY COURSE OF DEALING OR USAGE OF TRADE. IN NO EVENT SHALL SMSC BE LIABLE FOR ANY DIRECT, INCIDENTAL, INDIRECT, SPECIAL, PUNITIVE, OR CONSEQUENTIAL DAMAGES; OR FOR LOST DATA, PROFITS, SAVINGS OR REVENUES OF ANY KIND; REGARDLESS OF THE FORM OF ACTION, WHETHER BASED ON CONTRACT; TORT; NEGLIGENCE OF SMSC OR OTHERS; STRICT LIABILITY; BREACH OF WARRANTY; OR OTHERWISE; WHETHER OR NOT ANY REMEDY OF BUYER IS HELD TO HAVE FAILED OF ITS ESSENTIAL PURPOSE, AND WHETHER OR NOT SMSC HAS BEEN ADVISED OF THE POSSIBILITY OF SUCH DAMAGES.

Table of Contents

Chapter 1 Terms and Abbreviations	10
Chapter 2 Pin Description	12
Chapter 3 Electrical Specifications	15
3.1 ESD & Transient Performance	26
3.1.1 Human Body Model (HBM) Performance	26
3.1.2 Charged Device Model (CDM) Performance	26
3.1.3 IEC61000-4-2 Performance	26
Chapter 4 Communications	27
4.1 Operating Mode	27
4.2 SMBus Operating Mode	28
4.2.1 System Management Bus	28
4.2.2 SMBus and I ² C Compatibility	30
4.2.3 SMBus Protocols	30
4.2.4 I ² C Protocols	31
4.3 Stand-alone Operating Mode	32
Chapter 5 General Description	34
5.1 UCS1002 Power States	38
5.1.1 Off State Operation	39
5.1.2 Sleep State Operation	40
5.1.3 Detect State Operation	41
5.1.4 Active State Operation	42
5.1.5 Error State Operation	43
5.2 Supply Voltages	43
5.2.1 VDD Supply Voltage	43
5.2.2 VS Source Voltage	43
5.2.3 Back-voltage Detection	44
5.2.4 Back-drive Current Protection	44
5.2.5 Under-voltage Lockout on VS	44
5.2.6 Over-voltage Detection and Lockout on VS	44
5.3 Discrete Input Pins	44
5.3.1 COMM_SEL / ILIM Input	44
5.3.2 SEL Input	44
5.3.3 M1, M2, and EM_EN Inputs	45
5.3.4 PWR_EN Input	45
5.3.5 Latch Input	45
5.3.6 S0 Input	45
5.4 Discrete Output Pins	45
5.4.1 ALERT# and A_DET# Output Pins	45
5.4.2 Interrupt Blanking	46
Chapter 6 USB High-speed Data Switch	47
6.1 USB High-speed Data Switch	47
6.1.1 USB-IF High-speed Compliance	47

Chapter 7 USB Port Power Switch	48
7.1 USB Port Power Switch	48
7.2 Current Limiting	48
7.2.1 Current Limit Setting	48
7.2.2 Short Circuit Output Current Limiting	48
7.2.3 Soft Start	48
7.2.4 Current Limiting Modes	48
7.3 Thermal Management and Voltage Protection	51
7.3.1 Thermal Management	51
7.4 VBUS Discharge	53
7.5 Battery Full	53
7.5.1 Charge Rationing Interactions	55
7.6 Fault Handling Mechanism	56
7.6.1 Auto-recovery Fault Handling	57
7.6.2 Latched Fault Handling	57

Chapter 8 Detect State	58
8.1 Device Attach / Removal Detection	58
8.2 VBUS Bypass Switch	58
8.3 Attach Detection	58
8.4 Removal Detection	58

Chapter 9 Active State	60
9.1 Active State Overview	60
9.2 Active Mode Selection	60
9.3 BC1.2 Detection Renegotiation	60
9.4 Data Pass-through (No Charger Emulation)	60
9.5 BC1.2 SDP (No Charger Emulation)	61
9.6 BC1.2 CDP	61
9.6.1 BC1.2 CDP Charger Emulation Profile	61
9.7 BC1.2 DCP	62
9.7.1 BC1.2 DCP Charger Emulation Profile	62
9.8 Dedicated Charger	62
9.8.1 Emulation Reset	62
9.8.2 Emulation Cycling	63
9.8.3 DCE Cycle Retry	63
9.9 Current Limit Mode Associations	64
9.10 No Handshake	64
9.11 Preloaded Charger Emulation Profiles	65
9.11.1 BC1.2 DCP Charger Emulation Profile Within DCE Cycle	65
9.11.2 Legacy 2 Charger Emulation Profile	65
9.11.3 Legacy 1, 3, 4, and 6 Charger Emulation Profiles	66
9.11.4 Legacy 5 Charger Emulation Profile	66
9.11.5 Legacy 7 Charger Emulation Profile	66
9.12 Custom Charger Emulation Profile	67

Chapter 10 Register Description	68
10.1 Current Measurement Register	71
10.2 Total Accumulated Charge Registers	72
10.3 Status Registers	73

10.3.1 Other Status - 0Fh	73
10.3.2 Interrupt Status - 10h	74
10.3.3 General Status - 11h	75
10.3.4 Profile Status 1 - 12h	75
10.3.5 Profile Status 2 - 13h	76
10.3.6 Pin Status Register - 14h	77
10.4 Configuration Registers	78
10.4.1 General Configuration - 15h	78
10.4.2 Emulation Configuration - 16h	79
10.4.3 Switch Configuration - 17h	80
10.4.4 Attach Detection Configuration - 18h	81
10.4.5 High-speed Switch Configuration - 25h	82
10.5 Current Limit Register	82
10.6 Charge Rationing Threshold Registers	83
10.7 Auto-recovery Configuration Register	84
10.8 IBUS_CHG Configuration Register	85
10.9 tDET_CHARGE Configuration Register	85
10.10 Preloaded Emulation Enable Registers	87
10.10.1 BCS Emulation Enable - 20h	87
10.10.2 Legacy Emulation Enable - 21h	87
10.11 Preloaded Emulation Timeout Configuration Registers	88
10.11.1 BCS Emulation Timeout Config - 22h	88
10.11.2 Legacy Emulation Timeout Config 1 - 23h	89
10.11.3 Legacy Emulation Timeout Config 2 - 24h	89
10.12 Preloaded Emulation Configuration Registers	90
10.12.1 Applied Charger Emulation - 30h	91
10.12.2 Preloaded Emulation Configuration Registers 31h - 3Bh	91
10.12.3 Preloaded Emulation Stimulus X - Config 1 - 31h, 35h, 39h	92
10.12.4 BC1.2 Emulation Stimulus X - Config 2 - 32h, 36h, 3Ah	93
10.12.5 Emulation Stimulus X - Config 3 - 33h, 37h, 3Bh	97
10.12.6 Emulation Stimulus X - Config 4 - 34h, 38h	98
10.13 Custom Emulation Configuration Registers	99
10.13.1 Custom Emulation Configuration - 40h	100
10.13.2 Custom Stimulus / Response Pair X - Config 1 - 41h, 45h, 49h	101
10.13.3 Custom Stimulus / Response Pair X - Config 2 - 42h, 46h, 4Ah	101
10.13.4 Custom Stimulus / Response Pair X - Config 3 - 43h, 47h, 4Bh	101
10.13.5 Custom Stimulus / Response Pair X - Config 4 - 44h, 48h, 4Ch	102
10.14 Current Limiting Behavior Configuration Registers	102
10.14.1 Applied Current Limiting Behavior - 50h	102
10.14.2 Custom Current Limiting Behavior Configuration - 51h	102
10.15 Product ID Register	103
10.16 Manufacturer ID Register	104
10.17 Revision Register	104

Chapter 11 Package Information	105
Chapter 12 Typical Operating Curves	107
Chapter 13 References	111
Chapter 14 Document Revision History	112

List of Tables

Table 1.1	Terms and Abbreviations	10
Table 2.1	UCS1002 Pin Description	12
Table 2.2	Pin Types	14
Table 3.1	Absolute Maximum Ratings	15
Table 3.2	Power Dissipation Summary	15
Table 3.3	Electrical Specifications	16
Table 3.4	ESD Ratings	26
Table 4.1	UCS1002 Communication Mode and ILIM Selection	27
Table 4.2	SEL Pin Decode	29
Table 4.3	Protocol Format	30
Table 4.4	Write Byte Protocol	31
Table 4.5	Read Byte Protocol	31
Table 4.6	Send Byte Protocol	31
Table 4.7	Receive Byte Protocol	31
Table 4.8	Block Write Protocol	32
Table 4.9	Block Read Protocol	32
Table 4.10	Stand-alone Fault and Attach Detection Selection	33
Table 5.1	Power States Control Settings	39
Table 7.1	Charge Rationing Behavior	54
Table 7.2	Charge Rationing Reset Behavior	54
Table 7.3	Effects of Changing Rationing Behavior after Threshold Reached	55
Table 9.1	Active Mode Selection	60
Table 9.2	Current Limit Mode Options	64
Table 10.1	Register Set in Hexadecimal Order	68
Table 10.2	Current Measurement Register	71
Table 10.3	Total Accumulated Charge Registers	72
Table 10.4	Status Registers	73
Table 10.5	EM_STEP Bit Decode	74
Table 10.6	PWR_STATE Bit Decode	77
Table 10.7	Configuration Registers	78
Table 10.8	EM_RESET_TIME Bit Decode	80
Table 10.9	Discharge Time Options	81
Table 10.10	Attach / Removal Detection Threshold Options	81
Table 10.11	Current Limit Register	82
Table 10.12	ILIM_SW Bit Decode	83
Table 10.13	Charge Rationing Threshold Registers	83
Table 10.14	Auto-recovery Configuration Register	84
Table 10.15	t _{CYCLE} Options	84
Table 10.16	TRST_SW Options	84
Table 10.17	VTST_SW Options	85
Table 10.18	IBUS_CHG Configuration Register	85
Table 10.19	tDET_CHARGE Configuration Register	85
Table 10.20	DC_TEMP_SET Bit Decode	86
Table 10.21	DET_CHARGE_SET Bit Decode	86
Table 10.22	Preloaded Emulation Enable Registers	87
Table 10.23	Preloaded Emulation Timeout Configuration Registers	88
Table 10.24	X_EM_TIMEOUT Bit Decode	89
Table 10.25	Preloaded Emulation Configuration Registers	90
Table 10.26	Applied Emulation Selection	91
Table 10.27	Stimulus Delay Time Options	92

Table 10.28	Stimulus Options	93
Table 10.29	Stimulus Response	94
Table 10.30	Response Magnitude Meaning	95
Table 10.31	Voltage Divider Minimum Impedance Options	95
Table 10.32	Stimulus Response Resistor Options	96
Table 10.33	Stimulus Response Voltage Options	96
Table 10.34	Pull-Down Magnitude	97
Table 10.35	Stimulus Threshold Values	98
Table 10.36	Voltage Divider Ratio Options	99
Table 10.37	Custom Emulation Configuration Registers	99
Table 10.38	Current Limit Behavior Configuration Registers	102
Table 10.39	V_{BUS_MIN} Threshold Options	103
Table 10.40	I_{BUS_R2MIN} Threshold Options	103
Table 10.41	Product ID Register	103
Table 10.42	Manufacturer ID Register	104
Table 10.43	Revision Register	104
Table 14.1	Customer Revision History	112

List of Figures

Figure 2.1	UCS1002 Pin Diagram	12
Figure 3.1	USB Rise Time / Fall Time Measurement	25
Figure 3.2	Description of DC Terms	25
Figure 4.1	SMBus Timing Diagram	28
Figure 5.1	UCS1002 Full-Featured System Configuration (SMBus Control)	34
Figure 5.2	UCS1002 System Configuration (Charger Emulation, No SMBus, with USB Host)	35
Figure 5.3	UCS1002 System Configuration (No SMBus, No Charger Emulation)	36
Figure 5.4	UCS1002 System Configuration (No SMBus, No USB Host, with Charger Emulation)	37
Figure 5.5	Wake Timing via External Pins	40
Figure 5.6	Wake Via SMBus Read with S0 = '0'	41
Figure 7.1	Trip Current Limiting Operation	50
Figure 7.2	Constant Current Limiting (Variable Slope) Operation	51
Figure 7.3	Error Recovery Timing (Short Circuit Example)	57
Figure 8.1	Detect State VBUS Biasing	58
Figure 11.1	UCS1002 Package View	105
Figure 11.2	UCS1002 Package Dimensions and Notes	106
Figure 12.1	USB-IF High-speed Eye Diagram (without data switch)	107
Figure 12.2	USB-IF High-speed Eye Diagram (with data switch)	107
Figure 12.3	Short Applied After Power Up	107
Figure 12.4	Power Up Into A Short	107
Figure 12.5	Internal Power Switch Short Response	107
Figure 12.6	VBUS Discharge Behavior	107
Figure 12.7	Data Switch Off Isolation vs. Frequency	108
Figure 12.8	Data Switch Bandwidth vs. Frequency	108
Figure 12.9	Data Switch On Resistance vs. Temp	108
Figure 12.10	Power Switch On Resistance vs. Temp	108
Figure 12.11	R_{DCP_RES} Resistance vs. Temp	108
Figure 12.12	Power Switch On / Off Time vs. Temp	108
Figure 12.13	VS Over-Voltage Threshold vs. Temp	109
Figure 12.14	VS Under Voltage Threshold vs. Temp	109
Figure 12.15	Detect State VBUS vs. IBUS	109
Figure 12.16	Trip Current Limit Operation vs. Temp	109
Figure 12.17	IBUS Measurement Accuracy	109
Figure 12.18	Active State Current vs. Temp	110
Figure 12.19	Detect State Current vs. Temp	110
Figure 12.20	Sleep State Current vs. Temp	110

Chapter 1 Terms and Abbreviations

APPLICATION NOTE: The M1, M2, PWR_EN, and EM_EN pins each have configuration bits (<pin name>_SET in [Section 10.4.3, "Switch Configuration - 17h"](#)) that may be used to perform the same function as the external pin state. These bits are accessed via the SMBus / I²C and are OR'd with the respective pin. This OR'd combination of pin state and register bit is referenced as the <pin name> control.

Table 1.1 Terms and Abbreviations

TERM / ABBREVIATION	DESCRIPTION
Active mode	Active power state operation mode: Data Pass-through, BC1.2 SDP, BC1.2 CDP, BC1.2 DCP, or Dedicated Charger Emulation Cycle.
Attach Detection	An Attach Detection event occurs when the current drawn by a portable device is greater than I _{DET_QUAL} for longer than t _{DET_QUAL} .
attachment	The physical insertion of a portable device into a USB port that UCS1002 is controlling.
CC	Constant current
CDM	Charged Device Model. JEDEC model for characterizing susceptibility of a device to damage from ESD.
CDP or USB-IF BC1.2 CDP	Charging downstream port. The combination of the UCS1002 CDP handshake and an active standard USB host comprises a CDP. This enables a BC1.2 compliant portable device to simultaneously draw current up to 1.5 A while data communication is active. The USB high-speed data switch is closed in this mode.
charge enable	When a charger emulation profile has been accepted by a portable device and charging commences.
charger emulation profile	Representation of a charger comprised of DPOUT, DMOUT, and VBUS signalling which make up a defined set of signatures or handshaking protocols.
connection	USB-IF term which refers to establishing active USB communications between a USB host and a USB device.
current limiting mode	Determines the action that is performed when the IBUS current reaches the ILIM threshold. Trip opens the port power switch. Constant current (variable slope) allows VBUS to be dropped by the portable device.
DCE	Dedicated charger emulation. Charger emulation in which the UCS1002 can deliver power only (by default). No active USB data communication is possible when charging in this mode (by default).
DCP or USB-IF BC1.2 DCP	Dedicated Charging Port. This functions as a dedicated charger for a BC1.2 portable device. This allows the portable device to draw currents up to 1.5 A with constant current limiting (and beyond 1.5 A with trip current limiting). No USB communications are possible (by default).
DC	Dedicated charger. A charger which inherently does not have USB communications, such as an A/C wall adapter.
disconnection	USB-IF term which refers to the loss of active USB communications between a USB host and a USB device.

Table 1.1 Terms and Abbreviations (continued)

TERM / ABBREVIATION	DESCRIPTION
dynamic thermal management	The UCS1002 automatically adjusts port power switch limits and modes to lower internal power dissipation when the thermal regulation temperature value is approached.
enumeration	A USB-specific term that indicates that a host is detecting and identifying USB devices.
handshake	Application of a charger emulation profile that requires a response. Two-way communication between the UCS1002 and the portable device.
HBM	Human Body Model.
HSW	High-speed switch.
I_{BUS_R2MIN}	Current limiter mode boundary.
ILIM	The IBUS current threshold used in current limiting. In trip mode, when ILIM is reached, the port power switch is opened. In constant current mode, when the current exceeds ILIM, operation continues at a reduced voltage and increased current; if VBUS voltage drops below V_{BUS_MIN} , the port power switch is opened.
Legacy	USB devices that require non-BC1.2 signatures be applied on the DPOUT and DMOUT pins to enable charging.
OCL	Over-current limit.
POR	Power-on reset.
portable device	USB device attached to the USB port.
power thief	A USB device that does not follow the handshaking conventions of a BC1.2 device or Legacy devices and draws current immediately upon receiving power (i.e., a USB book light, portable fan, etc).
Removal Detection	A Removal Detection event occurs when the current load on the VBUS pin drops to less than I_{REM_QUAL} for longer than t_{REM_QUAL} .
removal	The physical removal of a portable device from a USB port that the UCS1002 is controlling.
response	An action, usually in response to a stimulus, in charger emulation performed by the UCS1002 device via the USB data lines.
SDP or USB-IF SDP	Standard downstream port. The combination of the UCS1002 high-speed switch being closed with an upstream USB host present comprises a BC1.2 SDP. This enables a BC1.2 compliant portable device to simultaneously draw current up to 0.5 A while data communication is active.
signature	Application of a charger emulation profile without waiting for a response. One-way communication from the UCS1002 to the portable device.
Stand-alone mode	Indicates that the communications protocol is not active and all communications between the UCS1002 and a controller are done via the external pins only (M1, M2, EM_EN, PWR_EN, S0, and LATCH as inputs and ALERT# and A_DET# as outputs).
stimulus	An event in charger emulation detected by the UCS1002 device via the USB data lines.

Chapter 2 Pin Description

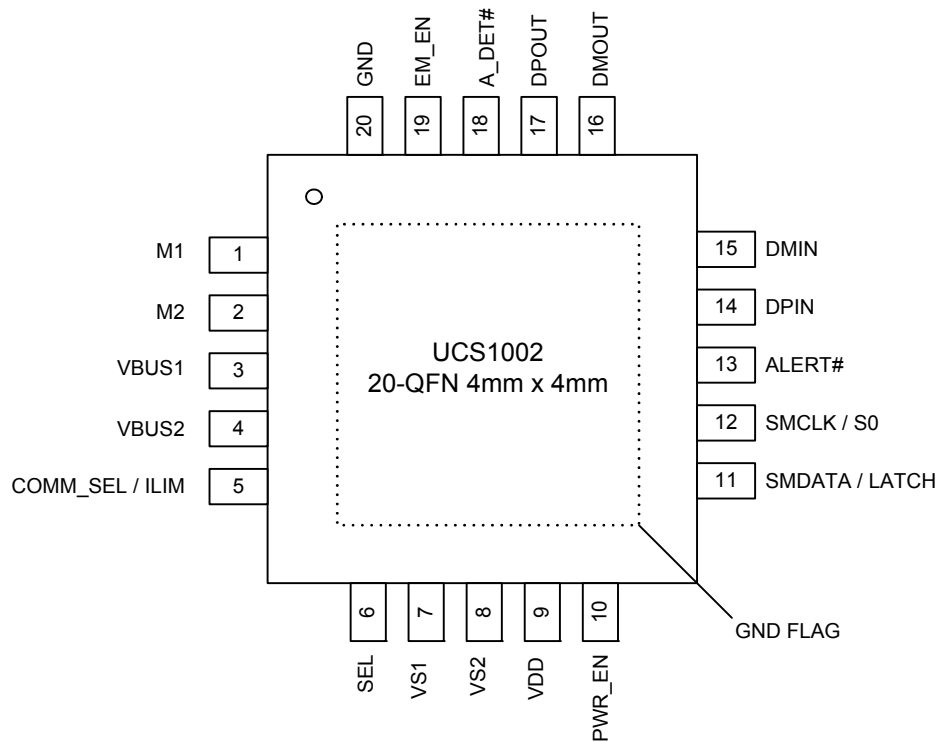

Figure 2.1 UCS1002 Pin Diagram

The pin types are described in [Table 2.2](#). All pins are 5 V tolerant.

Table 2.1 UCS1002 Pin Description

PIN NUMBER	PIN NAME	PIN FUNCTION	PIN TYPE	IF PIN NOT USED CONNECTION
1	M1	Active mode selector input #1	DI	Connect to ground or VDD (see Note 2.3)
2	M2	Active mode selector input #2	DI	Connect to ground or VDD (see Note 2.3)
3	VBUS1	Voltage output from Power Switch. These pins must be tied together.	Hi-Power, AIO Note 2.1	Leave open
4	VBUS2			

Table 2.1 UCS1002 Pin Description (continued)

PIN NUMBER	PIN NAME	PIN FUNCTION	PIN TYPE	IF PIN NOT USED CONNECTION
5	COMM_SEL / ILIM	COMM_SEL - Selects SMBus address or Stand-alone mode of operation	AIO	n/a
		ILIM - Selects the maximum current limit at power-up		
6	SEL	Selects whether PWR_EN is active high or active low and determines the SMBus address	AIO	n/a
7	VS1	Voltage input to Power Switch. These pins must be tied together.	Hi-Power, AIO	Connect to ground
8	VS2			
9	VDD	Main power supply input for chip functionality	Power	n/a
10	PWR_EN	Port power switch enable input. Polarity determined by SEL pin.	DI	Connect to ground or VDD (see Note 2.3)
11	SMDATA / LATCH	SMDATA - SMBus data input/output (requires pull-up resistor)	DIOD	n/a
		LATCH - In Stand-alone mode, Latch / Auto-recovery fault handling mechanism selection input	DI	
12	SMCLK / S0	SMCLK - SMBus Clock Input (requires pull-up resistor)	DI	n/a
		S0 - In Stand-alone mode, enables Attach / Removal Detection feature		
13	ALERT#	Active low error event output flag (requires pull-up resistor)	OD	Connect to ground
14	DPIN	USB data input (plus)	AIO	Connect to ground or ground through a resistor
15	DMIN	USB data input (minus)	AIO	Connect to ground or ground through a resistor
16	DMOUT	USB data output (minus)	AIO (see Note 2.2)	Connect to ground
17	DPOUT	USB data output (plus)	AIO (see Note 2.2)	Connect to ground
18	A_DET#	Active low Attach Detection output flag (requires pull-up resistor)	OD	Connect to ground
19	EM_EN	Active mode selector input	DI	Connect to ground or VDD (see Note 2.3)

Table 2.1 UCS1002 Pin Description (continued)

PIN NUMBER	PIN NAME	PIN FUNCTION	PIN TYPE	IF PIN NOT USED CONNECTION
20	GND	Ground	Power	n/a
Bottom Pad	GND FLAG	Thermal connection to ground plane	Thermal Pad	n/a

Note 2.1 Total leakage current from pins 3 and 4 (VBUS) to ground must be less than 100 μ A for proper attach / removal detection operation.

Note 2.2 It is recommended to use 2 M Ω pull-down resistors on the DPOUT pin and / or DMOUT pin if a portable device stimulus is expected when using the Custom charger emulation profile with the high-speed data switch open. The 2 M Ω value is based on BC1.1 impedance characteristics for Dedicated Charging Ports.

Note 2.3 To ensure operation, the PWR_EN pin must be enabled, as determined by the SEL pin decode, when it is not driven by an external device. Furthermore, one of the M1, M2, or EM_EN pins must be connected to VDD if all three are not driven from an external device. If the PWR_EN is disabled or all of the M1, M2, and EM_EN are connected to ground, the UCS1002 will remain in the Sleep or Detect state unless activated via the SMBus.

Table 2.2 Pin Types

PIN TYPE	DESCRIPTION
Power	This pin is used to supply power or ground to the device.
Hi-Power	This pin is a high current pin.
AIO	Analog Input / Output - this pin is used as an I/O for analog signals.
DI	Digital Input - this pin is used as a digital input.
DIOD	Open-drain Digital Input / Output - this pin is bidirectional. It is open-drain and requires a pull-up resistor.
OD	Open-drain Digital Output - used as a digital output. It is open-drain and requires a pull-up resistor.

Chapter 3 Electrical Specifications

Table 3.1 Absolute Maximum Ratings

Voltage on VDD, VS, and VBUS pins	-0.3 to 6	V
Pullup voltage (V_{PULLUP})	-0.3 to VDD + 0.3	
Data switch current (I_{HSW_ON}), switch on	±50	mA
Port power switch current	Internally limited	
Data switch pin voltage to ground (DPOUT, DPIN, DMOUT, DMIN); (VDD powered or unpowered)	-0.3 to VDD + 0.3	V
Differential voltage across open data switch (DPOUT - DPIN, DMOUT - DMIN, DPIN - DPOUT, DMIN - DMOUT)	VDD	V
Voltage on any other pin to ground	-0.3 to VDD + 0.3	V
Current on any other pin	±10	mA
Package power dissipation	See Table 3.2	
Operating ambient temperature range	-40 to 125	°C
Storage temperature range	-55 to 150	°C

Note: Stresses above those listed could cause permanent damage to the UCS1002. This is a stress rating only and functional operation of the UCS1002 at any other condition above those indicated in the operation sections of this specification is not implied.

Table 3.2 Power Dissipation Summary

BOARD	PKG	θ_{JC}	θ_{JA}	DERATING FACTOR ABOVE 25 °C	TA < 25 °C POWER RATING	TA = 70 °C POWER RATING	TA = 85 °C POWER RATING
High K (see Note 3.1)	20-pin QFN 4 mm x 4 mm	6 °C / W	41 °C / W	24.4 mW / °C	2193 mW	1095 mW	729 mW
Low K (see Note 3.1)	20-pin QFN 4 mm x 4 mm	6 °C / W	60 °C / W	16.67 mW / °C	1498 mW	748 mW	498 mW

Note 3.1 A High K board uses a thermal via design with the thermal landing soldered to the PCB ground plane with 0.3 mm (12 mil) diameter vias in a 3x3 matrix (9 total) at 0.5 mm (20 mil) pitch. The board is multi-layer with 1-ounce internal power and ground planes and 2-ounce copper traces on top and bottom. A Low K board is a two layer board without thermal via design with 2-ounce copper traces on the top and bottom.

Table 3.3 Electrical Specifications

VDD = 4.5 V to 5.5 V, VS = 2.9 V to 5.5 V, VPULLUP = 3 V to 5.5 V, TA = -40 °C to 85 °C all Typical values at VDD = VS = 5 V, TA = 27 °C unless otherwise noted.						
CHARACTERISTIC	SYMBOL	MIN	TYP	MAX	UNIT	CONDITIONS
Power and Interrupts - DC						
Supply Voltage	VDD	4.5	5	5.5	V	See Note 3.2
Source Voltage	VS	2.9	5	5.5	V	See Note 3.2
Supply Current in Active ($I_{DD_ACTIVE} + I_{VS_ACT}$)	I_{ACTIVE}		650	750	μA	Average current IBUS = 0 mA
Supply Current in Sleep ($I_{DD_SLEEP} + I_{VS_SLEEP}$)	I_{SLEEP}		5	15	μA	Average current $V_{PULLUP} \leq VDD$
Supply Current in Detect ($I_{DD_DETECT} + I_{VS_DETECT}$)	I_{DETECT}		185	220	μA	Average current No portable device attached.
Power-on Reset						
VS Low Threshold	V_{S_UVLO}		2.5	2.7	V	VS voltage increasing
VS Low Hysteresis	$V_{S_UVLO_HYST}$		100		mV	VS voltage decreasing
VDD Low Threshold	V_{DD_TH}		4	4.4	V	VDD voltage increasing
VDD Low Hysteresis	$V_{DD_TH_HYST}$		500		mV	VDD voltage decreasing
I/O Pins - SMCLK, SMDATA, EM_EN, M1, M2, PWR_EN, ALERT#, A_DET# - DC Parameters						
Output Low Voltage	V_{OL}			0.4	V	$I_{SINK_IO} = 8\text{ mA}$ SMDATA, ALERT#, A_DET#
Input High Voltage	V_{IH}	2.0			V	PWR_EN, EM_EN, M1, M2, SMDATA, SMCLK
Input Low Voltage	V_{IL}			0.8	V	PWR_EN, EM_EN, M1, M2, EM_EN, SMDATA, SMCLK
Leakage Current	I_{LEAK}			± 5	μA	Powered or unpowered $V_{PULLUP} \leq VDD$ $T_A < 85\text{ }^\circ C$
Interrupt Pins - AC Parameters						
ALERT#, A_DET# Pin Blanking Time	t_{BLANK}		25		ms	
ALERT# Pin Interrupt Masking Time	t_{MASK}		5		ms	

Table 3.3 Electrical Specifications (continued)

VDD = 4.5 V to 5.5 V, VS = 2.9 V to 5.5 V, VPULLUP = 3 V to 5.5 V, TA = -40 °C to 85 °C all Typical values at VDD = VS = 5 V, TA = 27 °C unless otherwise noted.						
CHARACTERISTIC	SYMBOL	MIN	TYP	MAX	UNIT	CONDITIONS
SMBus / I²C Timing						
Input Capacitance	C _{IN}		5		pF	
Clock Frequency	f _{SMB}	10		400	kHz	
Spike Suppression	t _{SP}			50	ns	
Bus Free Time Stop to Start	t _{BUF}	1.3			μs	
Start Setup Time	t _{SU:STA}	0.6			μs	
Start Hold Time	t _{HD:STA}	0.6			μs	
Stop Setup Time	t _{SU:STO}	0.6			μs	
Data Hold Time	t _{HD:DAT}	0			μs	When transmitting to the master
Data Hold Time	t _{HD:DAT}	0.3			μs	When receiving from the master
Data Setup Time	t _{SU:DAT}	0.6			μs	
Clock Low Period	t _{LOW}	1.3			μs	
Clock High Period	t _{HIGH}	0.6			μs	
Clock / Data Fall Time	t _{FALL}			300	ns	Min = 20+0.1C _{LOAD} ns
Clock / Data Rise Time	t _{RISE}			300	ns	Min = 20+0.1C _{LOAD} ns
Capacitive Load	C _{LOAD}			400	pF	Per bus line
Timeout	t _{TIMEOUT}	25		35	ms	Disabled by default
Idle Reset	t _{IDLE_RESET}	350			μs	Disabled by default.
High-speed Data Switch						
High-speed Data Switch - DC Parameters						
Switch Leakage Current	I _{HSW_OFF}		±0.5		μA	Switch open - DPIN to DPOUT, DMIN to DMOUT, or all four pins to ground. VDD ≤ VS.
Charger Resistance	R _{CHG}	2			MΩ	DPOUT or DMOUT to VBUS or ground, see Figure 3.2 BC1.2 DCP charger emulation active

Table 3.3 Electrical Specifications (continued)

VDD = 4.5 V to 5.5 V, VS = 2.9 V to 5.5 V, VPULLUP = 3 V to 5.5 V, TA = -40 °C to 85 °C all Typical values at VDD = VS = 5 V, TA = 27 °C unless otherwise noted.						
CHARACTERISTIC	SYMBOL	MIN	TYP	MAX	UNIT	CONDITIONS
On Resistance	R _{ON_HSW}		2		Ω	Switch closed, VDD = 5 V test current = 8 mA, test voltage = 0.4 V, see Figure 3.2
On Resistance	R _{ON_HSW_1}		5		Ω	Switch closed, VDD = 5 V, test current = 8 mA, test voltage = 3.0 V, see Figure 3.2
Delta On Resistance	ΔR _{ON_HSW}		±0.3		Ω	Switch closed, VDD = 5 V I _{TST} = 8 mA, V _{TST} = 0 to 1.5 V, see Figure 3.2
High-speed Data Switch - AC Parameters						
DP, DM Capacitance to Ground	C _{HSW_ON}		4		pF	Switch closed VDD = 5 V
DP, DM Capacitance to Ground	C _{HSW_OFF}		2		pF	Switch open VDD = 5 V
Turn Off Time	t _{HSW_OFF}		400		μs	Time from state control (EM_EN, M1, M2) switch on to switch off, R _{TERM} = 50 Ω, C _{LOAD} = 5 pF
Turn On Time	t _{HSW_ON}		400		μs	Time from state control (EM_EN, M1, M2) switch off to switch on, R _{TERM} = 50 Ω, C _{LOAD} = 5 pF
Propagation Delay	t _{PD}		0.25		ns	R _{TERM} = 50 Ω, C _{LOAD} = 5 pF
Propagation Delay Skew	Δt _{PD}		25		ps	R _{TERM} = 50 Ω, C _{LOAD} = 5 pF
Rise/Fall Time	t _{F/R}		10		ns	R _{TERM} = 50 Ω, C _{LOAD} = 5 pF
DP - DM Crosstalk	X _{TALK}		-40		dB	R _{TERM} = 50 Ω, C _{LOAD} = 5 pF
Off Isolation	O _{IRR}		-30		dB	R _{TERM} = 50 Ω, C _{LOAD} = 5 pF f = 240 MHz
-3dB Bandwidth	BW		1100		MHz	R _{TERM} = 50 Ω, C _{LOAD} = 1.5 pF V _{DPOUT} = V _{DMOUT} = 350 mV DC
Total Jitter	t _J		200		ps	R _{TERM} = 50 Ω, C _{LOAD} = 5 pF, rise time = fall time = 500 ps at 480 Mbps (PRBS = 2 ¹⁵ - 1)
Skew of Opposite Transitions of the Same Output	t _{SK(P)}		20		ps	R _{TERM} = 50 Ω, C _{LOAD} = 5 pF

Table 3.3 Electrical Specifications (continued)

VDD = 4.5 V to 5.5 V, VS = 2.9 V to 5.5 V, VPULLUP = 3 V to 5.5 V, TA = -40 °C to 85 °C all Typical values at VDD = VS = 5 V, TA = 27 °C unless otherwise noted.						
CHARACTERISTIC	SYMBOL	MIN	TYP	MAX	UNIT	CONDITIONS
Port Power Switch						
Port Power Switch - DC Parameter						
Over-voltage Lockout	VS_OV		6		V	
On Resistance	RON_PSW		55	65	mΩ	4.75 V < VS < 5.25 V
VS Leakage Current	ILEAK_VS		2.2	5	μA	Sleep state into VS pin
Back-voltage Protection Threshold	VBV_TH		150		mV	VBUS > VS VS > VS_UVLO
Back-drive Current	IBD_1		0	3	μA	VDD < VDD_TH. Any powered power pin to any unpowered power pin. Current out of unpowered pin.
	IBD_2		0	2	μA	VDD > VDD_TH. Any powered power pin to any unpowered power pin, except for VDD to VBUS in Detect power state and VS to VBUS in Active power state. Current out of unpowered pin.
Selectable Current Limits	ILIM1	450	467	500	mA	ILIM Resistor = 0 or 47 kΩ (500 mA setting)
	ILIM2	810	839	900	mA	ILIM Resistor = 10 kΩ or 56 kΩ (900 mA setting)
	ILIM3	900	932	1000	mA	ILIM Resistor = 12 kΩ or 68 kΩ (1000 mA setting)
	ILIM4	1080	1112	1200	mA	ILIM Resistor = 15 kΩ or 82 kΩ (1200 mA setting)
	ILIM5	1350	1385	1500	mA	ILIM Resistor = 18 kΩ or 100 kΩ (1500 mA setting)
	ILIM6	1620	1702	1800	mA	ILIM Resistor = 22 kΩ or 120 kΩ (1800 mA setting)
	ILIM7	1800	1892	2000	mA	ILIM Resistor = 27 kΩ or 150 kΩ (2000 mA setting)
	ILIM8	2250	2355	2500	mA	ILIM Resistor = 33 kΩ or VDD (2500 mA setting)
Pin Wake Time	tPIN_WAKE		3		ms	

Table 3.3 Electrical Specifications (continued)

VDD = 4.5 V to 5.5 V, VS = 2.9 V to 5.5 V, VPULLUP = 3 V to 5.5 V, TA = -40 °C to 85 °C all Typical values at VDD = VS = 5 V, TA = 27 °C unless otherwise noted.						
CHARACTERISTIC	SYMBOL	MIN	TYP	MAX	UNIT	CONDITIONS
SMBus Wake Time	t _{SMB_WAKE}		4		ms	
Idle Sleep Time	t _{IDLE_SLEEP}		200		ms	
Thermal Regulation Limit	T _{REG}		110		°C	Die Temperature at which current limit will be reduced
Thermal Regulation Hysteresis	T _{REG_HYST}		10		°C	Hysteresis for t _{REG} functionality. Temperature must drop by this value before ILIM value restored to normal operation
Thermal Shutdown Threshold	T _{TSD}		135		°C	Die Temperature at which port power switch will turn off
Thermal Shutdown Hysteresis	T _{TSD_HYST}		35		°C	After shutdown due to T _{TSD} being reached, die temperature drop required before port power switch can be turned on again
Auto-recovery Test Current	I _{TEST}		190		mA	Portable device attached, VBUS = 0 V, Die temp < T _{TSD}
Auto-recovery Test Voltage	V _{TEST}		750		mV	Portable device attached, VBUS = 0 V before application, Die temp < T _{TSD} Programmable, 250 - 1000 mV, default listed
Discharge Impedance	R _{DISCHARGE}	100			Ω	
Port Power Switch - AC Parameters						
Turn On Delay	t _{ON_PSW}		0.75		ms	PWR_EN active toggle to switch on time, VBUS discharge not active
Turn Off Time	t _{OFF_PSW_INA}		0.75		ms	PWR_EN inactive toggle to switch off time C _{BUS} = 120 μF
Turn Off Time	t _{OFF_PSW_ERR}		1		ms	Over-current Error, VBUS Min Error, or Discharge Error to switch off C _{BUS} = 120 μF
Turn Off Time	t _{OFF_PSW_ERR}		100		ns	TSD or Back-drive Error to switch off C _{BUS} = 120 μF
VBUS Output Rise Time	t _{R_BUS}		1.1		ms	Measured from 10% to 90% of VBUS, C _{LOAD} = 220 μF ILIM = 1.0 A

Table 3.3 Electrical Specifications (continued)

VDD = 4.5 V to 5.5 V, VS = 2.9 V to 5.5 V, VPULLUP = 3 V to 5.5 V, TA = -40 °C to 85 °C all Typical values at VDD = VS = 5 V, TA = 27 °C unless otherwise noted.						
CHARACTERISTIC	SYMBOL	MIN	TYP	MAX	UNIT	CONDITIONS
Soft Turn on Rate	$\Delta I_{BUS} / \Delta t$		100		mA / μ s	
Temperature Update Time	t _{DC_TEMP}		200		ms	Programmable 200 - 1600 ms, default listed
Short Circuit Response Time	t _{SHORT_LIM}		1.5		μ s	Time from detection of short to current limit applied. No C _{BUS} applied
Short Circuit Detection Time	t _{SHORT}		6		ms	Time from detection of short to port power switch disconnect and ALERT# pin assertion.
Latched Mode Cycle Time	t _{UL}		7		ms	From PWR_EN edge transition from inactive to active to begin error recovery
Auto-recovery Mode Cycle Time	t _{CYCLE}		25		ms	Time delay before error condition check Programmable 15-50 ms, default listed
Auto-recovery Delay	t _{RST}		20		ms	Portable device attached, VBUS must be $\geq V_{TEST}$ after this time Programmable 10-25 ms, default listed
Discharge Time	t _{DISCHARGE}		200		ms	Amount of time discharge resistor applied Programmable 100-400 ms, default listed
Port Power Switch Operation With Trip Mode Current Limiting						
Region 2 Current Keep-out	I _{BUS_R2MIN}			0.1	A	
Minimum VBUS Allowed at Output	V _{BUS_MIN}	2.0			V	
Port Power Switch Operation With Constant Current Limiting (Variable Slope)						
Region 2 Current Keep-out	I _{BUS_R2MIN}			1.5	A	
Minimum VBUS Allowed at Output	V _{BUS_MIN}	2.0			V	
Port Power Switch Operation With Custom Current Limiting						
Region 2 Current Keep-out	I _{BUS_R2MIN}			0.1	A	Programmable from 100 mA to 1.8 A. Default value listed.

Table 3.3 Electrical Specifications (continued)

VDD = 4.5 V to 5.5 V, VS = 2.9 V to 5.5 V, V _{PULLUP} = 3 V to 5.5 V, T _A = -40 °C to 85 °C all Typical values at VDD = VS = 5 V, T _A = 27 °C unless otherwise noted.						
CHARACTERISTIC	SYMBOL	MIN	TYP	MAX	UNIT	CONDITIONS
Minimum VBUS Allowed at Output	V _{BUS_MIN}	2.0			V	Programmable from 1.5 V to 2.25 V. Default value listed.
Current Measurement - DC						
Current Measurement Range	I _{BUS_M}	6.4		2500	mA	Range (see Note 3.3)
Reported Current Measurement Resolution	ΔI _{BUS_M}		9.76		mA	1 LSB
Current Measurement Accuracy			±2		%	ILIM not exceeded
Current Measurement - AC						
Sampling Rate			500		μs	
Charge Rationing - DC						
Accumulated Current Measurement Accuracy			±4.5		%	
Charge Rationing - AC						
Current Measurement Update Time	t _{PCYCLE}		1		s	
Attach / Removal Detection						
VBUS Bypass - DC						
On Resistance	R _{ON_BYP}		50		Ω	
Leakage Current	I _{LEAK_BYP}			3	μA	Switch off
Current Limit	I _{DET_CHG} / I _{BUS_BYP}		2		mA	VDD = 5 V and VBUS > 4.75 V
Attach / Removal Detection - DC						
Attach Detection Threshold	I _{DET_QUAL}		800		μA	Programmable 200-1000 μA, default listed
Primary Removal Detection Threshold	I _{REM_QUAL_ACT}		700		μA	Programmable 100-900 μA, default listed Active power state
	I _{REM_QUAL_DET}		800		μA	Programmable 200-1000 μA, default listed Detect power state (see Section 8.4)

Table 3.3 Electrical Specifications (continued)

VDD = 4.5 V to 5.5 V, VS = 2.9 V to 5.5 V, VPULLUP = 3 V to 5.5 V, TA = -40 °C to 85 °C all Typical values at VDD = VS = 5 V, TA = 27 °C unless otherwise noted.						
CHARACTERISTIC	SYMBOL	MIN	TYP	MAX	UNIT	CONDITIONS
Attach / Removal Detection - AC						
Attach Detection Time	t _{DET_QUAL}		100		ms	Time from Attach to A_DET# assert .
Removal Detection Time	t _{REM_QUAL}		1000		ms	
Allowed Charge Time	t _{DET_CHARGE}		800		ms	C _{BUS} = 500 µF max Programmable 200-2000 ms, default listed
Charger Emulation Profile						
General Emulation - DC						
Charging Current Threshold	I _{BUS_CHG}		9.76		mA	default
Charging Current Threshold Range	I _{BUS_CHG_RNG}	9.76		155	mA	Programmable, all typical
DP-DM Shunt Resistor Value	R _{DGP_RES}			200	Ω	Connected between DPOUT and DMOUT 0 V < DPOUT = DMOUT ≤ 3 V
Response Magnitude (voltage divider option min resistance range)	SX_RXMAG_DVDR	93		200	kΩ	Programmable, all mins
Resistor Ratio Range (voltage divider option)	SX_RATIO	0.25		0.66	V / V	Programmable, all typical
Resistor Ratio Accuracy (voltage divider option)	SX_RATIO_ACC		±0.5		%	Average over range
Response Magnitude (resistor option range)	SX_RXMAG_RES	1.8		150	kΩ	Programmable, all typical
Internal Resistor Tolerance (resistor option)	SX_RXMAG_RES_ACC		±10		%	Average over range
Response Magnitude (voltage option range)	SX_RXMAG_VOLT	0.4		2.2	V	Programmable, all typical
Voltage Option Accuracy	SX_RXMAG_VOLT_ACC		±1		%	No load Average over range
Voltage Option Accuracy	SX_RXMAG_VOLT_ACC_150		-6		%	150 µA load Average over range
Voltage Option Accuracy	SX_RXMAG_VOLT_ACC_250		-10		%	250 µA load Average over range

Table 3.3 Electrical Specifications (continued)

VDD = 4.5 V to 5.5 V, VS = 2.9 V to 5.5 V, VPULLUP = 3 V to 5.5 V, TA = -40 °C to 85 °C all Typical values at VDD = VS = 5 V, TA = 27 °C unless otherwise noted.						
CHARACTERISTIC	SYMBOL	MIN	TYP	MAX	UNIT	CONDITIONS
Voltage Option Output	SX_RXMAG_VOLT_BC	0.5			V	DMOUT = 0.6 V 250 µA load
Response Magnitude (zero volt option range)	SX_PUPD	10		150	µA	SX_RXMAG_VOLT = 0 Programmable, all typical
Pull-down Current Accuracy	SX_PUPD_ACC_3p6		±5		%	DPOUT or DMOUT = 3.6 V Compliance voltage
Pull-down Current	SX_PUPD_ACC_BC	50			µA	Setting = 100 µA DPOUT or DMOUT = 0.15 V Compliance voltage
Stimulus Voltage Threshold Range	SX_TH	0.3		2.2	V	Programmable, all typical
Stimulus Voltage Accuracy	SX_TH_ACC		±2		%	Average over range
Stimulus Voltage Accuracy	SX_TH_ACC_BC	0.25			V	At SX_TH = 0.3 V
Stimulus Voltage Hysteresis	SX_TH_HYST		40		mV	Voltage falling
General Emulation - AC						
Emulation Reset Time	t _{EM_RESET}		50		ms	default
Emulation Reset Time Range	t _{EM_RESET_RNG}	50		175	ms	Programmable, all typical
Emulation Timeout Range	t _{EM_TIMEOUT}	0.8		12.8	s	Programmable, 0.8 s to 12.8 s, all typical
Stimulus Delay, SX_TD Range	t _{STIM_DEL}	0		100	ms	Programmable, all typical
Emulation Delay	t _{RES_EM}			0.5	s	Time from set impedance to impedance appears on DP / DM

Note 3.2 For split supply systems using the Attach Detection feature, VS must not exceed VDD + 150 mV.

Note 3.3 The current measurement full scale range maximum value is 2.5 A. However, the UCS1002 cannot report values above ILIM (if I_{BUS_R2MIN} ≤ ILIM) or above I_{BUS_R2MIN} (if I_{BUS_R2MIN} > ILIM and ILIM ≤ 1.5 A).

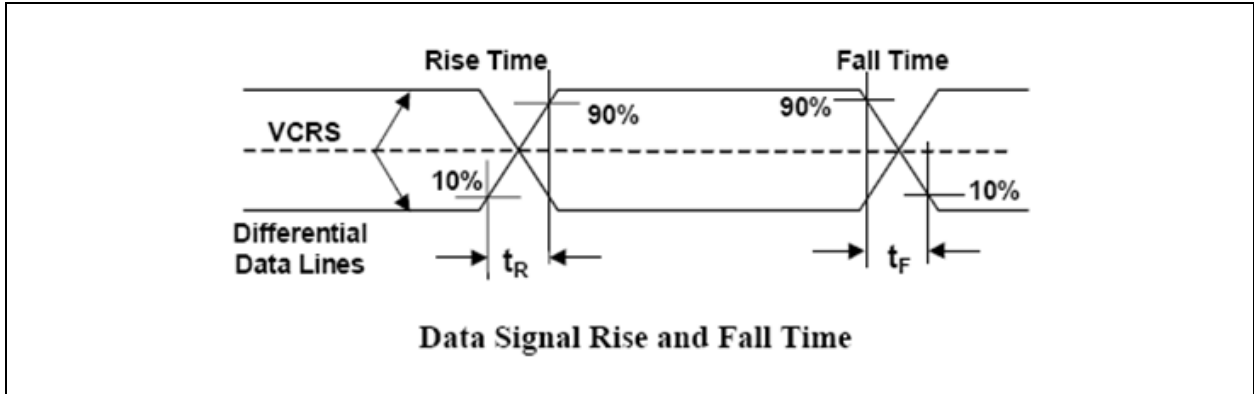

Figure 3.1 USB Rise Time / Fall Time Measurement

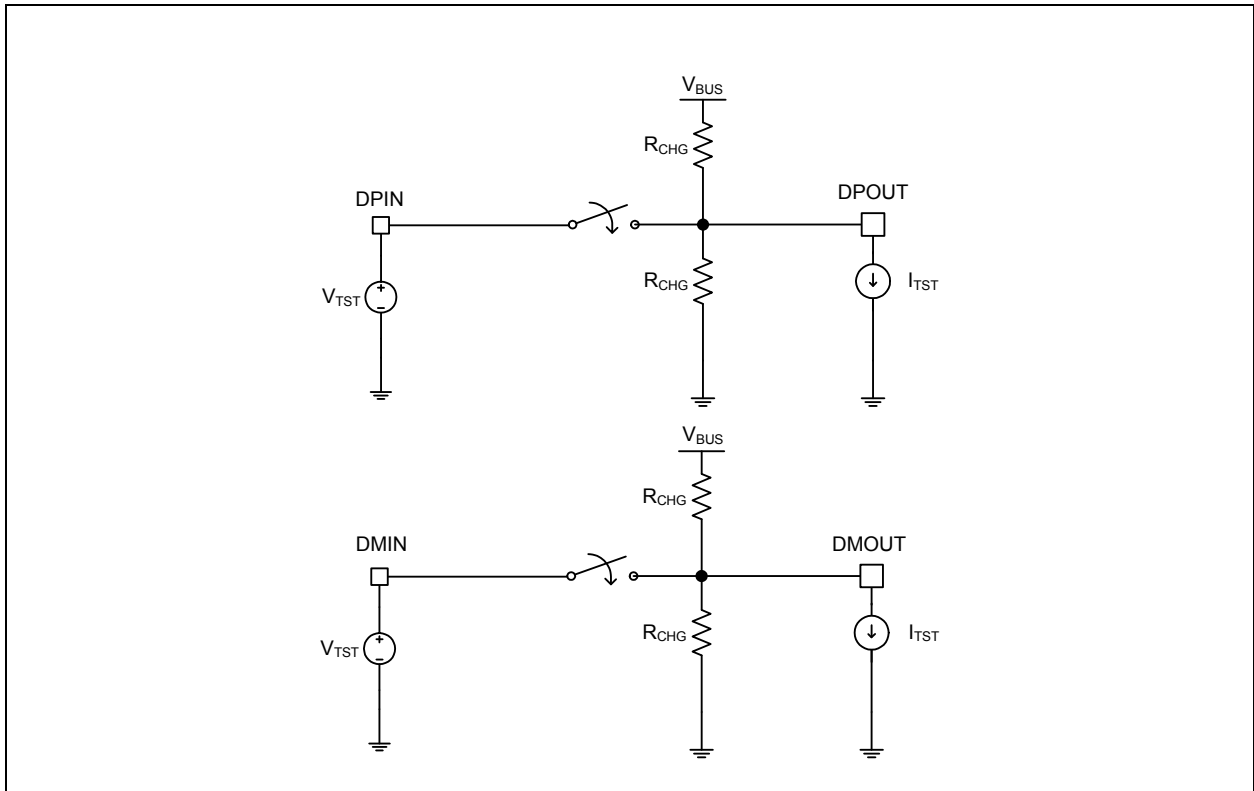

Figure 3.2 Description of DC Terms

3.1 ESD & Transient Performance

APPLICATION NOTE: Depending on the level of ESD protection required by the application, external protection devices may be required. The datasheet ESD levels were reached using external devices and standard USB-A connectors; refer to the EVB schematic and reference design for details.

Table 3.4 ESD Ratings

ESD SPEC	RATING OR VALUE
EN / IEC61000-4-2 (DPOUT, DMOUT pins) air gap, Operational Classification B (see Note 3.4)	Level 4 (15 kV)
EN / IEC61000-4-2 (DPOUT, DMOUT pins) direct contact, Operational Classification B (see Note 3.4)	Level 4 (8 kV)
EN / IEC61000-4-2 (VBUS, GND pins) air gap, Operational Classification A (see Note 3.5)	Level 4 (15 kV)
EN / IEC61000-4-2 (VBUS, GND pins) direct contact, Operational Classification A (see Note 3.5)	Level 4 (8 kV)
Human Body Model (JEDEC JESD22-A114) - All pins	8 kV
Charged Device Model (JEDEC JESD22-C101) - All pins	500 V

Note 3.4 Operational Classification B indicates that during and immediately after an ESD event, anomalous behavior may occur; however, it is non-damaging and the device is self-recovering. All IEC testing is performed using an SMSC evaluation board.

Note 3.5 Operational Classification A indicates that during and immediately after an ESD event no anomalous behavior will occur. All IEC testing is performed using an SMSC evaluation board.

3.1.1 Human Body Model (HBM) Performance

HBM testing verifies the ability to withstand ESD strikes like those that occur during handling and manufacturing and is done without power applied to the IC. To pass the test, the device must have no change in operation or performance due to the event.

3.1.2 Charged Device Model (CDM) Performance

CDM testing verifies the ability to withstand ESD strikes like those that occur during handling and assembly with pick and place style machinery and is done without power applied to the IC. To pass the test, the device must have no change in operation or performance due to the event.

3.1.3 IEC61000-4-2 Performance

The IEC61000-4-2 ESD specification is an international standard that addresses system-level immunity to ESD strikes while the end equipment is operational. These tests are performed while the device is powered.

Chapter 4 Communications

4.1 Operating Mode

The UCS1002 can operate in SMBus mode (see [Section 4.2, "SMBus Operating Mode"](#)) or Stand-alone mode (see [Section 4.3, "Stand-alone Operating Mode"](#)). The resistor on the COMM_SEL / ILIM pin determines operating mode and the hardware-set ILIM setting, as shown in [Table 4.1](#). Unless connected to GND or VDD, the resistors in [Table 4.1](#) are pull-down resistors.

APPLICATION NOTE: If it is necessary to connect the COMM_SEL / ILIM pin to VDD via a pull-up resistor, it is recommended that this resistor value not exceed 100 k Ω .

Table 4.1 UCS1002 Communication Mode and ILIM Selection

SELECTION RESISTOR $\pm 5\%$	ILIM SETTING	COMMUNICATIONS MODE
GND	500 mA	SMBus - see Section 4.2.1.2
10 k Ω pull-down	900 mA	SMBus - see Section 4.2.1.2
12 k Ω pull-down	1000 mA	SMBus - see Section 4.2.1.2
15 k Ω pull-down	1200 mA	SMBus - see Section 4.2.1.2
18 k Ω pull-down	1500 mA	SMBus - see Section 4.2.1.2
22 k Ω pull-down	1800 mA	SMBus - see Section 4.2.1.2
27 k Ω pull-down	2000 mA	SMBus - see Section 4.2.1.2
33 k Ω pull-down	2500 mA	SMBus - see Section 4.2.1.2
47 k Ω pull-down	500 mA	Stand-alone mode
56 k Ω pull-down	900 mA	Stand-alone mode
68 k Ω pull-down	1000 mA	Stand-alone mode
82 k Ω pull-down	1200 mA	Stand-alone mode
100 k Ω pull-down	1500 mA	Stand-alone mode
120 k Ω pull-down	1800 mA	Stand-alone mode
150 k Ω pull-down	2000 mA	Stand-alone mode
VDD (If a pull-up resistor is used, its value must not exceed 100 k Ω .)	2500 mA	Stand-alone mode

4.2 SMBus Operating Mode

When the COMM_SEL / ILIM pin is connected to directly to ground or through a pull-down resistor with a value of 33kΩ or below as listed in [Table 4.1, "UCS1002 Communication Mode and ILIM Selection"](#), the UCS1002 communicates via the SMBus or I²C communications protocols.

APPLICATION NOTE: Upon power-up, the UCS1002 will not respond to any SMBus communications for 5.5 ms. After this time, full functionality is available.

APPLICATION NOTE: When in the Sleep state, the first SMBus read command sent to the UCS1002 device address will wake it. Any data sent to the UCS1002 will be ignored and any data read from the UCS1002 should be considered invalid. The UCS1002 will be fully functional 3 ms after this first read command is sent. See [Section 5.1.2](#).

4.2.1 System Management Bus

In SMBus mode, the UCS1002 communicates with a host controller, such as an SMSC SIO. The SMBus is a two-wire serial communication protocol between a computer host and its peripheral devices. A detailed timing diagram is shown in [Figure 4.1](#). Stretching of the SMCLK signal is supported; however, the UCS1002 will not stretch the clock signal.

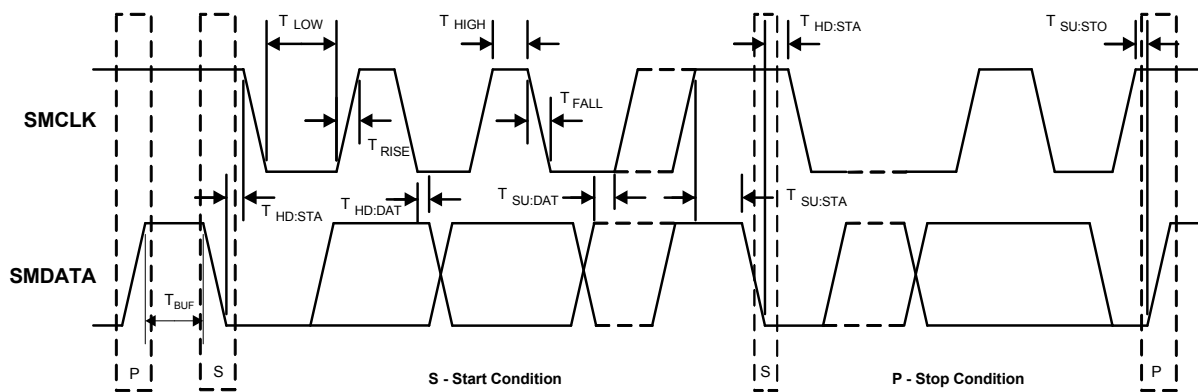

Figure 4.1 SMBus Timing Diagram

4.2.1.1 SMBus Start Bit

The SMBus Start bit is defined as a transition of the SMBus data line from a logic '1' state to a logic '0' state while the SMBus clock line is in a logic '1' state.

4.2.1.2 SMBus Address and RD / \overline{WR} Bit

The SMBus Address Byte consists of the 7-bit client address followed by the RD / \overline{WR} indicator bit. If this RD / \overline{WR} bit is a logic '0', the SMBus host is writing data to the client device. If this RD / \overline{WR} bit is a logic '1', the SMBus host is reading data from the client device.

The SMBus address is determined based on the resistor connected on the SEL pin as shown in [Table 4.2](#).

APPLICATION NOTE: If it is necessary to connect the SEL pin to VDD via a resistor, the pull-up resistor may be any value up to 100 kΩ.

Table 4.2 SEL Pin Decode

RESISTOR ($\pm 5\%$)	PWR_EN POLARITY	SMBUS ADDRESS
GND	Active Low	1010_111(r/w)
10 k Ω pull-down	Active Low	1010_110(r/w)
12 k Ω pull-down	Active Low	1010_101(r/w)
15 k Ω pull-down	Active Low	1010_100(r/w)
18 k Ω pull-down	Active Low	0110_000(r/w)
22 k Ω pull-down	Active Low	0110_001(r/w)
27 k Ω pull-down	Active Low	0110_010(r/w)
33 k Ω pull-down	Active Low	0110_011(r/w)
47 k Ω pull-down	Active High	0110_011(r/w)
56 k Ω pull-down	Active High	0110_010(r/w)
68 k Ω pull-down	Active High	0110_001(r/w)
82 k Ω pull-down	Active High	0110_000(r/w)
100 k Ω pull-down	Active High	1010_100(r/w)
120 k Ω pull-down	Active High	1010_101(r/w)
150 k Ω pull-down	Active High	1010_110(r/w)
VDD (If a pull-up resistor is used, its value must not exceed 100 k Ω .)	Active High	1010_111(r/w)

4.2.1.3 SMBus Data Bytes

All SMBus data bytes are sent most significant bit first and composed of 8-bits of information.

4.2.1.4 SMBus ACK and NACK Bits

The SMBus client will acknowledge all data bytes that it receives. This is done by the client device pulling the SMBus data line low after the 8th bit of each byte that is transmitted. This applies to both the Write Byte and Block Write protocols.

The host will NACK (not acknowledge) the last data byte to be received from the client by holding the SMBus data line high after the 8th data bit has been sent. For the Block Read protocol, the host will ACK each data byte that it receives except the last data byte.

4.2.1.5 SMBus Stop Bit

The SMBus Stop bit is defined as a transition of the SMBus data line from a logic '0' state to a logic '1' state while the SMBus clock line is in a logic '1' state. When the UCS1002 detects an SMBus Stop

bit, and it has been communicating with the SMBus protocol, it will reset its client interface and prepare to receive further communications.

4.2.1.6 SMBus Timeout and Idle Reset

The UCS1002 includes an SMBus timeout feature. If the clock is held at logic '0' for t_{TIMEOUT} , the device can timeout and reset the SMBus interface. The SMBus interface can also reset if both the clock and data lines are held at a logic '1' for $t_{\text{IDLE_RESET}}$. Communication is restored with a start condition. This functionality defaults to disabled and can be enabled by clearing the DIS_TO bit in the Emulation Configuration register (see [Section 10.4.2, "Emulation Configuration - 16h"](#)).

4.2.2 SMBus and I²C Compatibility

The major differences between SMBus and I²C devices are highlighted here. For more information, refer to the SMBus 2.0 and I²C specifications.

1. UCS1002 supports I²C fast mode at 400 kHz. This covers the SMBus max time of 100 kHz.
2. Minimum frequency for SMBus communications is 10 kHz.
3. The SMBus client protocol will reset if the clock is held at a logic '0' for longer than 30 ms. This timeout functionality is disabled by default in the UCS1002 and can be enabled by clearing the DIS_TO bit. I²C does not have a timeout.
4. Except when operating in Sleep, the SMBus client protocol will reset if both the clock and data lines are held at a logic '1' for longer than 200 μ s (idle condition). This function is disabled by default in the UCS1002 and can be enabled by clearing the DIS_TO bit. I²C does not have an idle condition.
5. I²C devices do not support the Alert Response Address functionality (which is optional for SMBus).
6. I²C devices support block read and write differently. I²C protocol allows for unlimited number of bytes to be sent in either direction. The SMBus protocol requires that an additional data byte indicating number of bytes to read / write is transmitted. The UCS1002 supports I²C formatting only.

4.2.3 SMBus Protocols

The UCS1002 is SMBus 2.0 compatible and supports Write Byte, Read Byte, Send Byte, and Receive Byte as valid protocols as shown below.

All of the below protocols use the convention in [Table 4.3](#).

Table 4.3 Protocol Format

DATA SENT TO DEVICE	DATA SENT TO THE HOST
Data sent	Data sent

4.2.3.1 SMBus Write Byte

The Write Byte is used to write one byte of data to a specific register as shown in [Table 4.4](#).

Table 4.4 Write Byte Protocol

START	CLIENT ADDRESS	WR	ACK	REGISTER ADDRESS	ACK	REGISTER DATA	ACK	STOP
1 -> 0	YYYY_YYY	0	0	XXh	0	XXh	0	0 -> 1

4.2.3.2 SMBus Read Byte

The Read Byte protocol is used to read one byte of data from the registers as shown in [Table 4.5](#).

Table 4.5 Read Byte Protocol

START	CLIENT ADDRESS	WR	ACK	REGISTER ADDRESS	ACK	START	CLIENT ADDRESS	RD	ACK	REGISTER DATA	NACK	STOP
1->0	YYYY_YYY	0	0	XXh	0	1 -> 0	YYYY_YYY	1	0	XXh	1	0 -> 1

4.2.3.3 SMBus Send Byte

The Send Byte protocol is used to set the internal address register pointer to the correct address location. No data is transferred during the Send Byte protocol as shown in [Table 4.6](#).

Table 4.6 Send Byte Protocol

START	CLIENT ADDRESS	WR	ACK	REGISTER ADDRESS	ACK	STOP
1 -> 0	YYYY_YYY	0	0	XXh	0	0 -> 1

4.2.3.4 SMBus Receive Byte

The Receive Byte protocol is used to read data from a register when the internal register address pointer is known to be at the right location (e.g., set via Send Byte). This is used for consecutive reads of the same register as shown in [Table 4.7](#).

Table 4.7 Receive Byte Protocol

START	CLIENT ADDRESS	RD	ACK	REGISTER DATA	NACK	STOP
1 -> 0	YYYY_YYY	1	0	XXh	1	0 -> 1

4.2.4 I²C Protocols

The UCS1002 supports I²C Block Read and Block Write. The protocols listed below use the convention in [Table 4.3](#).

4.2.4.1 Block Write

The Block Write is used to write multiple data bytes to a group of contiguous registers as shown in [Table 4.8](#).

APPLICATION NOTE: When using the Block Write protocol, the internal address pointer will be automatically incremented after every data byte is received. It will wrap from FFh to 00h.

Table 4.8 Block Write Protocol

START	CLIENT ADDRESS	WR	ACK	REGISTER ADDRESS	ACK	REGISTER DATA	ACK
1 -> 0	YYYY_YYY	0	0	XXh	0	XXh	0
REGISTER DATA	ACK	REGISTER DATA	ACK	...	REGISTER DATA	ACK	STOP
XXh	0	XXh	0	...	XXh	0	0 -> 1

4.2.4.2 Block Read

The Block Read is used to read multiple data bytes from a group of contiguous registers as shown in [Table 4.9](#).

APPLICATION NOTE: When using the Block Read protocol, the internal address pointer will be automatically incremented after every data byte is received. It will wrap from FFh to 00h.

Table 4.9 Block Read Protocol

START	CLIENT ADDRESS	WR	ACK	REGISTER ADDRESS	ACK	START	CLIENT ADDRESS	RD	ACK	REGISTER DATA
1->0	YYYY_YYY	0	0	XXh	0	1->0	YYYY_YYY	1	0	XXh
ACK	REGISTER DATA	ACK	REGISTER DATA	ACK	REGISTER DATA	ACK	...	REGISTER DATA	NACK	STOP
0	XXh	0	XXh	0	XXh	0	...	XXh	1	0 -> 1

4.3 Stand-alone Operating Mode

Stand-alone mode allows the UCS1002 to operate without active SMBus / I²C communications. Stand-alone mode can be enabled by connecting a pull-down resistor greater or equal to 47 kΩ on the COMM_SEL / ILIM pin as shown in [Table 4.1, "UCS1002 Communication Mode and ILIM Selection"](#).

When the device is configured to operate in Stand-alone mode, the fault handling and Attach Detection controls are determined via the LATCH and S0 pins as shown in [Table 4.10](#).

APPLICATION NOTE: If it is necessary to connect the S0 or LATCH pins to VDD via a pull-up resistor, the pull-up resistor value should be 100 kΩ in order to guarantee V_{IH} specification. Likewise, if it is necessary to connect the S0 or LATCH pins to GND via a pull-down resistor, the pull-down resistor value should be 100 kΩ in order to guarantee V_{IL} specification.

Table 4.10 Stand-alone Fault and Attach Detection Selection

LATCH PIN	S0 PIN	COMMAND
Low	Low	No Attach Detection. Auto-recovery upon error detection.
Low	High	Attach Detection in the Detect power state. Auto-recovery upon error detection.
High	Low	No Attach Detection. Error states are Latched and require host to change PWR_EN control to recover from Error state.
High	High	Attach Detection in the Detect power state. Error states are Latched and require host to change PWR_EN control to recover from Error state.

In the Stand-alone operating mode, communications from and to the UCS1002 are limited to the PWR_EN, EM_EN, M2, M1, ALERT#, and A_DET# pins.

Chapter 5 General Description

The UCS1002 provides a single USB port power switch for precise control of up to 2.5 amperes continuous current with over-current limit (OCL), dynamic thermal management, latch or auto-recovery fault handling, selectable active low or high enable, under- and over-voltage lockout, and back-voltage protection.

Split supply support for VBUS and VDD is an option for low power in system standby states.

In addition to power switching and current limiting, the UCS1002 provides automatic and configurable charger emulation profiles to charge a wide variety of portable devices, including USB-IF BC1.2 (CDP or DCP modes), YD/T-1591 (2009), most Apple and RIM portable devices, and many others.

The UCS1002 also provides current monitoring to allow intelligent management of system power and charge rationing for controlled delivery of current regardless of the host power state. This is especially important for battery operated applications that want to provide power and do not want to excessively drain the battery, or that require power allocation depending on application activities.

Figure 5.1 shows a UCS1002 full-featured system configuration in which the UCS1002 provides a port power switch and low power Attach Detection with wake-up signaling (wake on USB). The current limit is established at power-up. It can be lowered if required after power-up via the SMBus / I²C. This configuration also provides configurable USB data line charger emulation, programmable current limiting (as determined by the accepted charger emulation profile), active current monitoring, and port charge rationing.

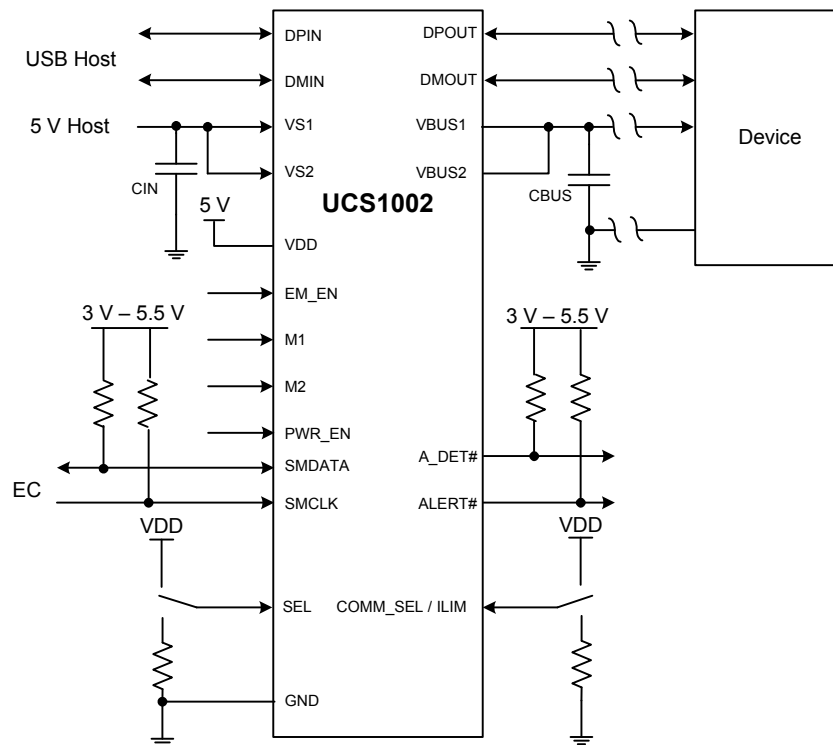

Figure 5.1 UCS1002 Full-Featured System Configuration (SMBus Control)

Figure 5.2 shows a system configuration in which the UCS1002 provides a USB data switch, port power switch, low power Attach Detection, and portable device Attach / Removal Detection signaling. This configuration does not include configurable data line charger emulation, programmable current limiting, or current monitoring and rationing.

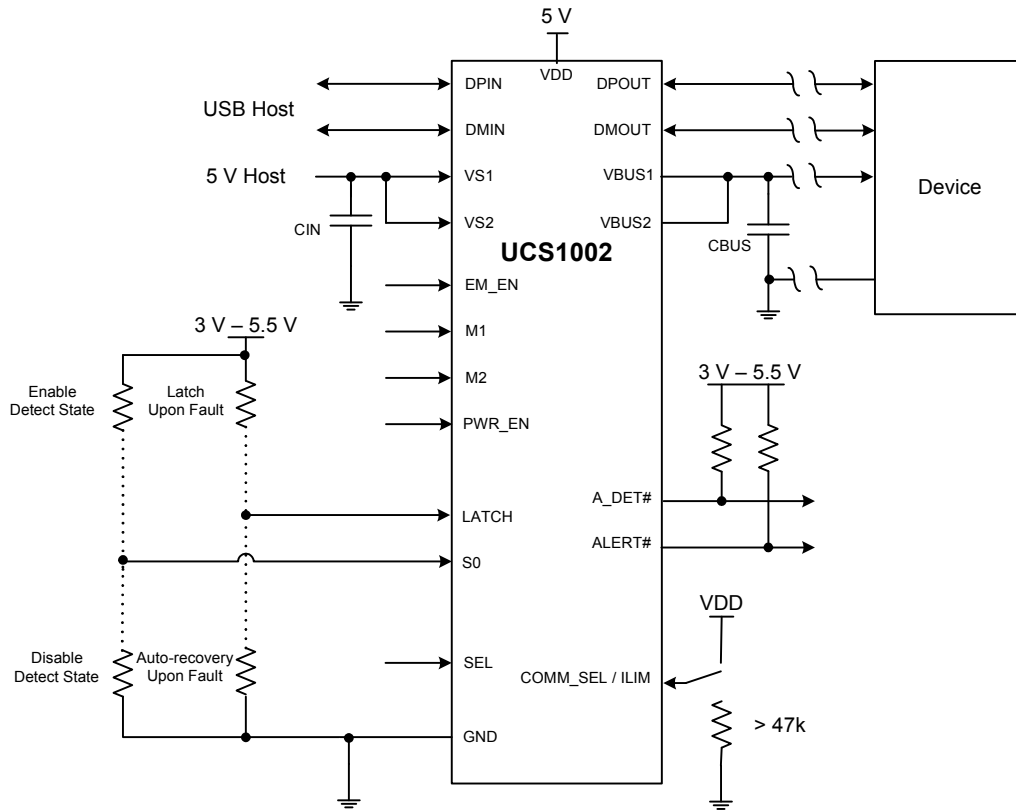

Figure 5.2 UCS1002 System Configuration (Charger Emulation, No SMBus, with USB Host)

Figure 5.3 shows a system configuration in which the UCS1002 provides a port power switch, low power Attach Detection, and portable device attachment detected signaling. This configuration is useful for applications that already provide USB BC1.2 and/or legacy data line handshaking on the USB data lines, but still require port power switching and current limiting.

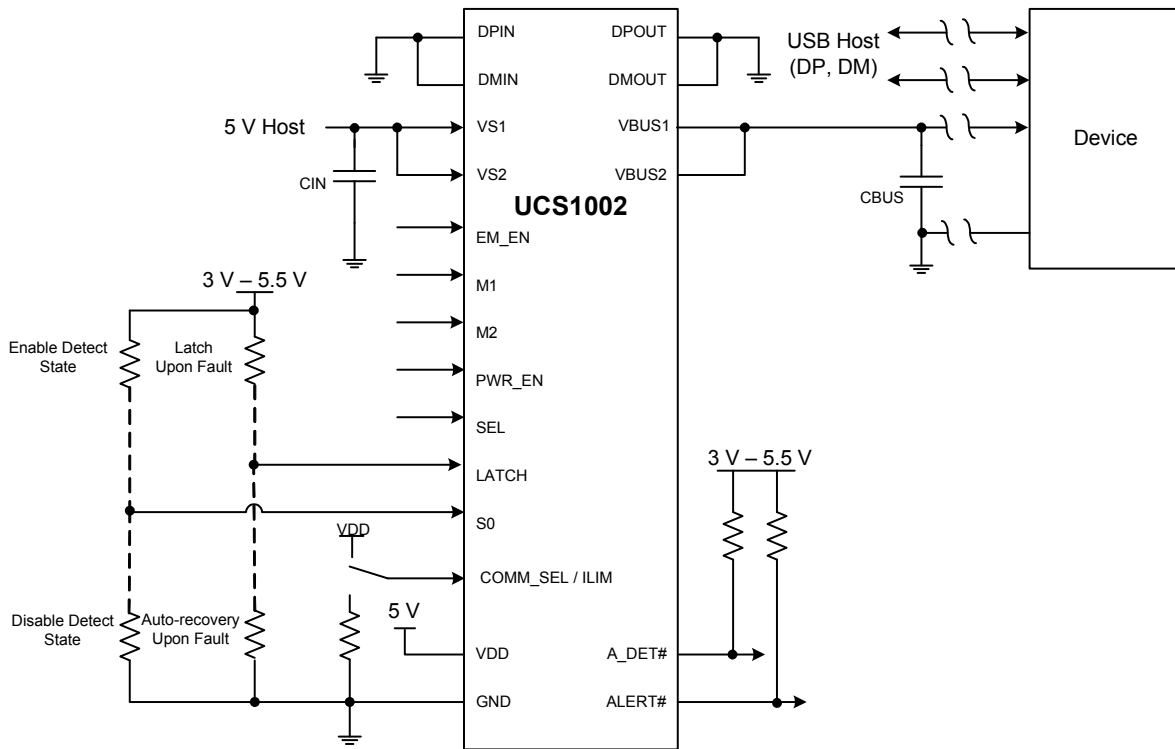

Figure 5.3 UCS1002 System Configuration (No SMBus, No Charger Emulation)

Figure 5.4 shows a system configuration in which the UCS1002 provides a port power switch, low power Attach Detection, charger emulation (with no USB host), and portable device attachment detected signaling. This configuration is useful for wall adapter type applications.

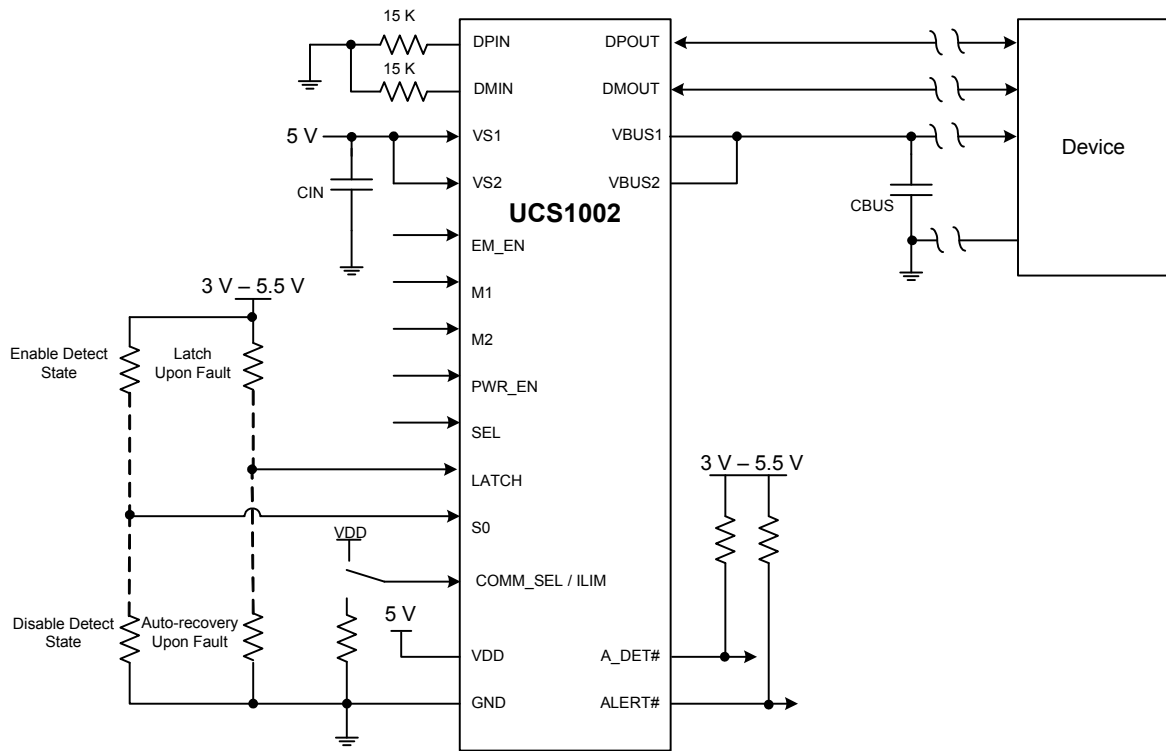

Figure 5.4 UCS1002 System Configuration (No SMBus, No USB Host, with Charger Emulation)

UCS1002 references design is available; contact your SMSC representative.

5.1 UCS1002 Power States

The UCS1002 has the following power states.

- **Off** - This power state is entered when the voltage at the VDD pin voltage is $< V_{DD_TH}$. In this state the device is considered “off”. The UCS1002 will not retain its digital states and register contents nor respond to SMBus / I²C communications. The port power switch, bypass switch, and the high-speed data switches will be off. See [Section 5.1.1, "Off State Operation"](#).
- **Sleep** - This is the lowest power state available. While in this state, the UCS1002 will retain digital functionality, respond to changes in emulation controls, and wake to respond to SMBus / I²C communications. The high-speed switch and all other functionality will be disabled. See [Section 5.1.2, "Sleep State Operation"](#).
- **Detect** - This is a lower current power state. In this state, the device is actively looking for a portable device to be attached. The high-speed switch is disabled by default. While in this state, the UCS1002 will retain the configuration and charge rationing data, but it will not monitor the bus current. SMBus / I²C communications will be fully functional. See [Section 5.1.3, "Detect State Operation"](#).
- **Error** - This power state is entered when a fault condition exists. See [Section 5.1.5, "Error State Operation"](#).
- **Active** - This power state provides full functionality. While in this state, operations include activation of the port power switch, USB data line handshaking / charger emulation, current limiting, and charge rationing. See [Section 5.1.4, "Active State Operation"](#).

Table 5.1 shows the settings for the various power states, except Off and Error. If $V_{DD} < V_{DD_TH}$, the UCS1002 is in the Off state. To determine the mode of operation in the Active state, see Table 9.1, "Active Mode Selection". For more information about configuring the UCS1002 to create single or dual mode charger solutions, see SMSC application note 24.20 "Using the UCS100x as a Single or Dual Mode Charger."

APPLICATION NOTE: Using configurations not listed in Table 5.1 is not recommended and may produce undesirable results.

Table 5.1 Power States Control Settings

POWER STATE	VS	PWR_EN	S0	M1, M2, EM_EN	PORTABLE DEVICE ATTACHED	BEHAVIOR
Sleep	X	disabled	0	Not set to Data Pass-through. See Note 5.1.	X	All switches disabled. VBUS will be near ground potential. The UCS1002 wakes to respond to SMBus communications.
	X	enabled	0	All = 0b	X	
Detect (see Chapter 8, Detect State)	X	disabled	1	X	X	High-speed switch disabled (by default). Port power switch disabled. Host-controlled transition to Active state (see Section 5.1.3.2, "Host-Controlled Transition from Detect to Active").
	< V_{S_UVLO}	enabled	1	All <> 0b	X	
	> V_{S_UVLO}	enabled	1	All <> 0b	No	High-speed switch disabled (by default). Automatic transition to Active state when conditions met (see Section 5.1.3.1, "Automatic Transition from Detect to Active").
Active (see Chapter 9, Active State)	> V_{S_UVLO}	enabled	0	All <> 0b	X	High-speed switch enabled / disabled based on mode. Port power switch is on at all times. Attach and Removal Detection disabled. See Note 5.2.
	> V_{S_UVLO}	enabled	1	All <> 0b	Yes	Port power switch is on. Removal Detection enabled.

Note 5.1 In order to transition from Active state Data Pass-through mode into Sleep with these settings, change the M1, M2, and EM_EN pins before changing the PWR_EN pin. See Section 9.4, "Data Pass-through (No Charger Emulation)".

Note 5.2 If S0='0' and a portable device is not attached in DCE Cycle mode, the UCS1002 will be cycling through charger emulation profiles (by default). There is no guarantee which charger emulation profile will be applied first when a portable device attaches.

5.1.1 Off State Operation

The device will be in the off state if V_{DD} is less than V_{DD_TH} . When the UCS1002 is in the Off state, it will do nothing, and all circuitry will be disabled. Digital register values are not stored and the device will not respond to SMBus commands.

5.1.2 Sleep State Operation

When the UCS1002 is in the Sleep state, the device will be in its lowest power state. The high-speed switch, bypass switch, and the port power switch will be disabled. The Attach and Removal Detection feature will be disabled. VBUS will be near ground potential. The ALERT# pin will not be asserted. If asserted prior to entering the Sleep state, the ALERT# pin will be released. The A_DET# pin will be released. SMBus activity is limited to single byte read or write.

The first data byte read from the UCS1002 when it is in the Sleep state will wake it; however, the data to be read will return all 0's and should be considered invalid. This is a “dummy” read byte meant to wake the UCS1002. Subsequent read or write bytes will be accepted normally. After the dummy read, the UCS1002 will be in a higher power state (see Figure 5.6). After communication has not occurred for t_{IDLE_SLEEP} , the UCS will return to Sleep.

Figure 5.5 shows timing diagrams for waking the UCS1002 via external pins. Figure 5.6 shows the timing for waking the UCS1002 via SMBus.

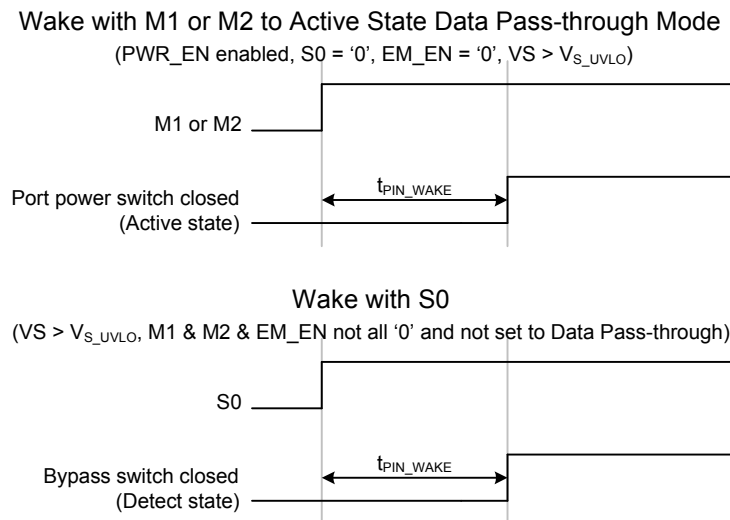

Figure 5.5 Wake Timing via External Pins

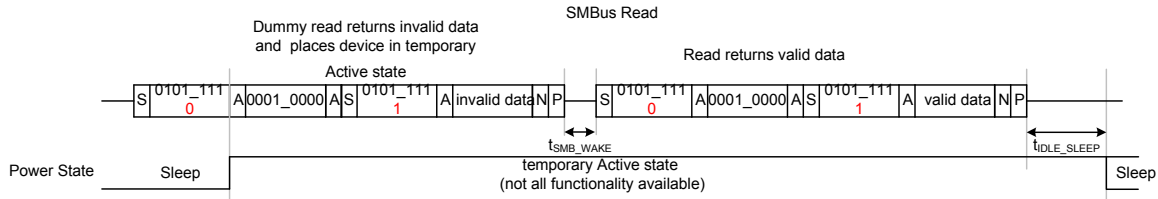

Figure 5.6 Wake Via SMBus Read with S0 = '0'

5.1.3 Detect State Operation

When the UCS1002 is in the Detect state, the port power switch will be disabled. The high-speed switch is also disabled by default. The VBUS output will be connected to the VDD voltage by a secondary bypass switch (see [Chapter 8, Detect State](#)).

There is one **non-recommended** configuration which places the UCS1002 in the Detect state, but V_{BUS} will not be discharged and a portable device attachment will not be detected. For the recommended configurations, see [Table 5.1, "Power States Control Settings"](#).

- **NOT RECOMMENDED:** PWR_EN is enabled, S0 = '1', and M1, M2, and EM_EN are all '0'.

There are two methods for transitioning from the Detect state to the Active state: automatic and host-controlled.

5.1.3.1 Automatic Transition from Detect to Active

For the Detect state, set S0 to '1', enable PWR_EN, set the EM_EN, M1, and M2 controls to the desired Active mode ([Table 9.1, "Active Mode Selection"](#)), and supply $V_S > V_{S_UVLO}$. When a portable device is attached and an Attach Detection event occurs, the UCS1002 will automatically transition to the Active state and operate according to the selected Active mode.

5.1.3.2 Host-Controlled Transition from Detect to Active

For the Detect state, set S0 to '1', set the EM_EN, M1, and M2 controls to the desired Active mode ([Table 9.1, "Active Mode Selection"](#)), and configure one of the following: 1) disable PWR_EN and supply VS, or 2) enable PWR_EN and don't supply VS. When a portable device is attached and an Attach Detection event occurs, the host must respond to transition to the Active state. Depending on the control settings in the Detect state, this could entail 1) enabling PWR_EN or 2) supplying VS above the threshold.

APPLICATION NOTE: If S0 is '1', PWR_EN is enabled, and VS is not present, the A_DET# pin will cycle if the current draw exceeds the current capacity of the bypass switch.

5.1.3.3 State Change from Detect to Active

When conditions cause the UCS1002 to transition from the Detect state to the Active state, the following occurs:

1. The Attach Detection feature will be disabled; the Removal Detection feature remains enabled, unless S0 is changed to '0'.

2. The bypass switch will be turned off.
3. The discharge switch will be turned on for $t_{\text{DISCHARGE}}$.
4. The port power switch will be turned on.

5.1.4 Active State Operation

Every time that the UCS1002 enters the Active state and the port power switch is closed, it will enter the mode as instructed by the host controller (see [Chapter 9, Active State](#)). The UCS1002 cannot be in the Active state (and therefore, the port power switch cannot be turned on) if any of the following conditions exist:

1. $V_S < V_{S_UVLO}$.
2. PWR_EN is disabled.
3. M1, M2, and EM_EN are all set to '0'.
4. S0 is set to '1' and an Attach Detection event has not occurred.

5.1.5 Error State Operation

The UCS1002 will enter the Error state from the Active state when any of the following events are detected:

1. The maximum allowable internal die temperature (T_{TSD}) has been exceeded (see [Section 7.3.1.2](#)).
2. An over-current condition has been detected (see [Section 7.2.1](#)).
3. An under-voltage condition on VBUS has been detected (see [Section 5.2.5](#)).
4. A back-drive condition has been detected (see [Section 5.2.3](#)).
5. A discharge error has been detected (see [Section 7.4](#)).
6. An over-voltage condition on the VS pins.

The UCS1002 will enter the Error state from the Detect state when a back-drive condition has been detected or when the maximum allowable internal die temperature has been exceeded.

The UCS1002 will enter the Error state from the Sleep state when a back-drive condition has been detected.

When the UCS1002 enters the Error state, the port power switch, the VBUS bypass switch, the high-speed switch are turned off, and the ALERT# pin is asserted (by default). They will remain off while in this power state. The UCS1002 will leave this state as determined by the fault handling selection (see [Section 7.6, "Fault Handling Mechanism"](#)).

When using the Latch fault handler and the user has re-activated the device by clearing the ERR bit (see [Section 10.3, "Status Registers"](#)), or toggling the PWR_EN control, the UCS1002 will check that all of the error conditions have been removed. If using Auto-recovery fault handler, after the t_{CYCLE} time period, the UCS1002 will check that all of the error conditions have been removed.

If all of the error conditions have been removed, the UCS1002 will return to the Active state or Detect state, as applicable. Returning to the Active state will cause the UCS1002 to restart the selected mode (see [Section 9.2, "Active Mode Selection"](#)).

If the device is in the Error state and a Removal Detection event occurs, it will check the error conditions and then return to the power state defined by the PWR_EN, M1, M2, EM_EN, and S0 controls.

5.2 Supply Voltages

5.2.1 VDD Supply Voltage

The UCS1002 requires 4.5 V to 5.5 V present on the VDD pin for core device functionality. Core device functionality consists of maintaining register states, wake-up upon SMBus / I²C query, and Attach Detection.

5.2.2 VS Source Voltage

VS can be a separate supply and can be greater than VDD to accommodate high current applications in which current path resistances result in unacceptable voltage drops that may prevent optimal charging of some portable devices.

5.2.3 Back-voltage Detection

Whenever the following conditions are true, the port power switch will be disabled, the VBUS bypass switch will be disabled, the high-speed data switch will be disabled, and a Back-voltage event will be flagged. This will cause the UCS1002 to enter the Error power state (see [Section 5.1.5, "Error State Operation"](#)).

1. The VBUS voltage exceeds the VS voltage by V_{BV_TH} and the port power switch is closed. The port power switch will be opened immediately. If the condition lasts for longer than t_{MASK} , then the UCS1002 will enter the Error state. Otherwise, the port power switch will be turned on as soon as the condition is removed.
2. The VBUS voltage exceeds the VDD voltage by V_{BV_TH} and the VBUS bypass switch is closed. The bypass switch will be opened immediately. If the condition lasts for longer than t_{MASK} , then the UCS1002 will enter the Error state. Otherwise, the bypass switch will be turned on as soon as the condition is removed.

5.2.4 Back-drive Current Protection

If a portable device is attached that is self-powered, it may drive the VBUS port to its power supply voltage level; however, the UCS1002 is designed such that leakage current from the VBUS pins to the VDD or VS pins shall not exceed I_{BD_1} (if the VDD voltage is zero) or I_{BD_2} (if the VDD voltage exceeds V_{DD_TH}).

5.2.5 Under-voltage Lockout on VS

The UCS1002 requires a minimum voltage (V_{S_UVLO}) be present on the VS pin for Active power state.

5.2.6 Over-voltage Detection and Lockout on VS

The UCS1002 port power switch will be disabled if the voltage on the VS pin exceeds a voltage (V_{S_OV}) for longer than the specified time (t_{MASK}). This will cause the device to enter the Error state.

5.3 Discrete Input Pins

APPLICATION NOTE: If it is necessary to connect any of the control pins except the COMM_SEL / ILIM or SEL pins via a resistor to VDD or GND, the resistor value should not exceed 100 k Ω in order to meet the VIH and VIL specifications.

5.3.1 COMM_SEL / ILIM Input

The COMM_SEL / ILIM input determines the initial ILIM settings and the communications mode, as shown in [Table 4.1, "UCS1002 Communication Mode and ILIM Selection"](#).

5.3.2 SEL Input

The SEL pin selects the polarity of the PWR_EN control. In addition, if the UCS1002 is not configured to operate in Stand-alone mode, the SEL pin determines the SMBus address. See [Table 4.2, "SEL Pin Decode"](#). The SEL pin state is latched upon device power-up and further changes will have no effect.

5.3.3 M1, M2, and EM_EN Inputs

The M1, M2, and EM_EN input controls determine the Active mode and affect the power state (see [Table 5.1, "Power States Control Settings"](#) and [Table 9.1, "Active Mode Selection"](#)). When these controls are all set to '0' and PWR_EN is enabled, the UCS1002 Attach and Removal Detection feature is disabled. In SMBus mode, the M1, M2, and EM_EN pin states will be ignored by the UCS1002 if the PIN_IGNORE configuration bit is set (see [Section 10.4.3](#)); otherwise, the M1_SET, M2_SET, and EM_EN_SET configuration bits (see [Section 10.4.3](#)) are checked along with the pins.

5.3.4 PWR_EN Input

The PWR_EN control enables the port power switch to be turned on if conditions are met and affects the power state (see [Table 5.1, "Power States Control Settings"](#)). The port power switch cannot be closed if PWR_EN is disabled. However, if PWR_EN is enabled, the port power switch is not necessarily closed (see [Section 5.1.4, "Active State Operation"](#)). Polarity is controlled by the SEL pin. In SMBus mode, the PWR_EN pin state will be ignored by the UCS1002 if the PIN_IGNORE configuration bit is set (see [Section 10.4.3](#)); otherwise, the PWR_EN_SET configuration bit (see [Section 10.4.3](#)) is checked along with the pin.

5.3.5 Latch Input

The Latch input control determines the behavior of the fault handling mechanism (see [Section 7.6, "Fault Handling Mechanism"](#)).

When the UCS1002 is configured to operate in Stand-alone mode (see [Section 4.3, "Stand-alone Operating Mode"](#)), the LATCH control is available exclusively via the LATCH pin (see [Section Table 4.10, "Stand-alone Fault and Attach Detection Selection"](#)). When the UCS1002 is configured to operate in SMBus mode, the LATCH control is available exclusively via the LATCH_SET configuration bit (see [Section 10.4.3, "Switch Configuration - 17h"](#)).

5.3.6 S0 Input

The S0 control enables the Attach and Removal Detection feature and affects the power state (see [Table 5.1, "Power States Control Settings"](#)). When S0 is set to '1', an Attach Detection event must occur before the port power switch can be turned on. When S0 is set to '0', the Attach and Removal Detection feature is not enabled.

When the device is configured to operate in SMBus mode, (see [Section 4.3, "Stand-alone Operating Mode"](#)), the S0 control is available exclusively via the S0_SET configuration bit (see [Section 10.4.3, "Switch Configuration - 17h"](#)). Otherwise, the S0 control is available exclusively via the S0 pin since the SMBus protocol will be disabled.

5.4 Discrete Output Pins

5.4.1 ALERT# and A_DET# Output Pins

The ALERT# pin is an active low open-drain interrupt to the host controller. The ALERT# pin is asserted (by default - see ALERT_MASK in [Section 10.4.1, "General Configuration - 15h"](#)) when an error occurs (see [Section 10.3.2, "Interrupt Status - 10h"](#)). The ALERT# pin can also be asserted when the LOW_CUR (portable device is pulling less current and may be finished charging) or TREG (thermal regulation temperature exceeded) bits are set and linked. As well, when charge rationing is enabled, the ALERT# pin is asserted by default when the current rationing threshold is reached (as determined by RATION_BEH[1:0] - see [Table 7.1, "Charge Rationing Behavior"](#)). The ALERT# pin is released when all conditions that may assert the ALERT# pin (such as an error condition, charge rationing, and TREG and LOW_CHG if linked) have been removed or reset as necessary.

The A_DET# pin provides an active low open-drain output indication that a valid Attach Detection event has occurred. It will remain asserted until the UCS1002 is placed into the Sleep state or a Removal Detection event occurs. For wake on USB, the A_DET# pin assertion can be utilized by the system. If the S0 control is '0' and the UCS1002 is in the Active state, the A_DET# pin will be asserted regardless if a portable device is attached or not. If S0 is '1', PWR_EN is enabled, and VS is not present, the A_DET# pin will cycle if the current draw exceeds the current capacity of the bypass switch.

5.4.2 Interrupt Blanking

The ALERT# and A_DET# pins will not be asserted for a specified time (up to t_{BLANK}) after power-up. Additionally, an error condition (except for the thermal shutdown) must be present for longer than a specified time (t_{MASK}) before the ALERT# pin is asserted.

Chapter 6 USB High-speed Data Switch

6.1 USB High-speed Data Switch

The UCS1002 contains a series USB 2.0 compliant high-speed switch between the DPIN and DMIN pins and between the DPOUT and DMOOUT pins. This switch is designed for high-speed, low latency functionality to allow USB 2.0 full-speed and high-speed communications with minimal interference.

Nominally, the switch is closed in the Active state, allowing uninterrupted USB communications between the upstream host and the portable device. The switch is opened when:

1. The UCS1002 is actively emulating using any of the charger emulation profiles except CDP (by default - see [Section 10.4.5, "High-speed Switch Configuration - 25h"](#)).
2. The UCS1002 is operating as a dedicated charger unless the HSW_DCE configuration bit is set (see [Section 10.4.5](#)).
3. The UCS1002 is in the Detect state (by default) or in the Sleep state.

APPLICATION NOTE: If the VDD voltage is less than V_{DD_TH} , the high-speed data switch will be disabled and opened.

6.1.1 USB-IF High-speed Compliance

The USB data switch will not significantly degrade the signal integrity through the device DP / DM pins with USB high-speed communications.

Chapter 7 USB Port Power Switch

7.1 USB Port Power Switch

To assure compliance to various charging specifications, the UCS1002 contains a USB port power switch that supports two current limiting modes: trip and constant current (variable slope). The current limit (ILIM) is pin selectable (and may be updated via the register set). The switch also includes soft start circuitry and a separate short circuit current limit.

The port power switch is on in the Active state (except when VBUS is discharging).

7.2 Current Limiting

7.2.1 Current Limit Setting

The UCS1002 hardware set current limit, ILIM, can be one of eight values (see [Table 4.1, "UCS1002 Communication Mode and ILIM Selection"](#)). This resistor value is read once upon UCS1002 power-up. The current limit can be changed via the SMBus / I²C after power-up; however, the programmed current limit cannot exceed the hardware set current limit.

At power-up, the communication mode (Stand-alone or SMBus / I²C) and hardware current limit (ILIM) are determined via the pull-down resistor (or pull-up resistor if connected to VDD) on the COMM_SEL / ILIM pin, as shown in [Table 4.1](#).

7.2.2 Short Circuit Output Current Limiting

Short circuit current limiting occurs when the output current is above the selectable current limit (I_{LIMx}). This event will be detected and the current will immediately be limited (within t_{SHORT_LIM} time). If the condition remains, the port power switch will flag an Error condition and enter the Error state (see [Section 5.1.5, "Error State Operation"](#)).

7.2.3 Soft Start

When the PWR_EN control changes states to enable the port power switch, or an Attach Detection event occurs in the Detect power state and the PWR_EN control is already enabled, the UCS1002 invokes a soft start routine for the duration of the VBUS rise time (t_{R_BUS}). This soft start routine will limit current flow from VS into VBUS while it is active. This circuitry will prevent current spikes due to a step in the portable device current draw.

In the case when a portable device is attached while the PWR_EN pin is already enabled, if the bus current exceeds ILIM, the UCS1002 current limiter will respond within a specified time (t_{SHORT_LIM}) and will operate normally at this point. The C_{BUS} capacitor will deliver the extra current, if any, as required by the load change.

7.2.4 Current Limiting Modes

The UCS1002 current limiting has two modes: trip and constant current (variable slope). Either mode functions at all times when the port power switch is closed. The current limiting mode used depends on the Active state mode (see [Section 9.9, "Current Limit Mode Associations"](#)). When operating in the Detect power state (see [Section 5.1.3](#)), the current capacity at VBUS is limited to I_{BUS_BYP} as described in [Section 8.2, "VBUS Bypass Switch"](#).

7.2.4.1 Trip Mode

When using trip current limiting, the UCS1002 USB port power switch functions as a low resistance switch and rapidly turns off if the current limit is exceeded. While operating using trip current limiting, the VBUS output voltage will be held relatively constant (equal to the VS voltage minus the $R_{ON} * I_{BUS}$ current) for all current values up to the ILIM.

If the current drawn by a portable device exceeds ILIM, the following occurs:

1. The port power switch will be turned off (trip action).
2. The UCS1002 will enter the Error state and assert the ALERT# pin.
3. The fault handling circuitry will then determine subsequent actions.

Trip current limiting is used by default when the UCS1002 is in Data Pass-through and Dedicated Charger Emulation Cycle (except when the BC1.2 DCP charger emulation profile is accepted), and when there's no handshake.

APPLICATION NOTE: To avoid cycling in trip mode, set ILIM higher than the highest expected portable device current draw.

Figure 7.1 shows operation of current limits in trip mode with the shaded area representing the USB 2.0 specified VBUS range. Dashed lines indicate the port power switch output will go to zero (e.g., trip) when ILIM is exceeded. Note that operation at all possible values of ILIM are shown in Figure 7.1 for illustrative purposes only; in actual operation only one ILIM can be active at any time.

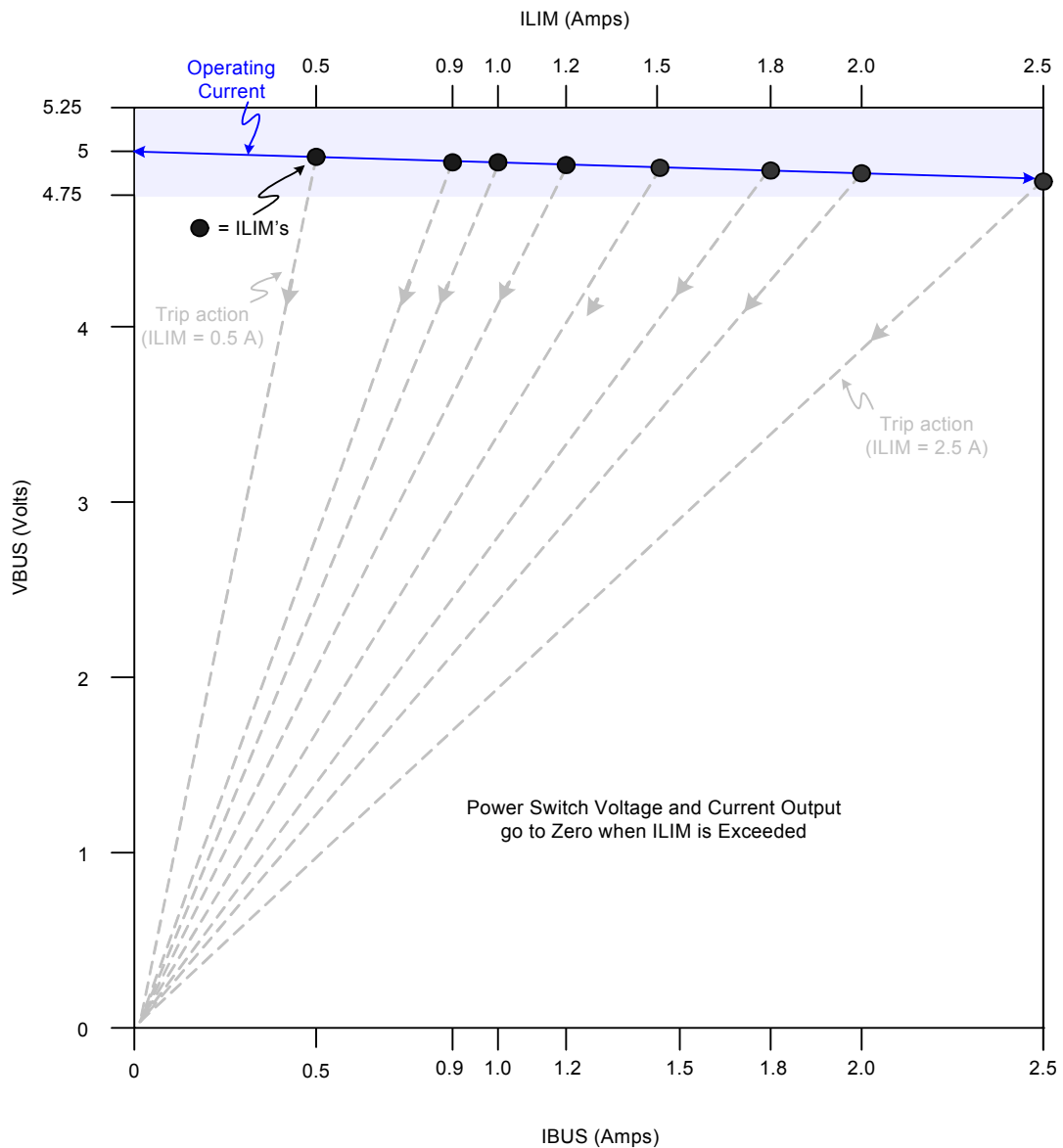

Figure 7.1 Trip Current Limiting Operation

7.2.4.2 Constant Current Limiting (Variable Slope)

Constant current limiting is used when a portable device handshakes using the BC1.2 DCP charger emulation profile and the current drawn is greater than ILIM (and $ILIM \leq 1.5\text{ A}$). It's also used in BC1.2 CDP mode and during the DCE Cycle when a charger emulation profile is being applied and the emulation timeout is active.

In CC mode, the port power switch allows the attached portable device to reduce VBUS output voltage to less than the input VS voltage while maintaining current delivery. The V/I slope depends on the user set ILIM value. This slope is held constant for a given ILIM value.

Figure 7.2 shows operation of current limits while using CC mode. Unlike trip mode, once IBUS current exceeds ILIM, operation continues at a reduced voltage and increased current. Note that the shaded area representing the USB 2.0 specified VBUS range is now restricted to an upper current limit of I_{BUS_R2MIN} . Note that the UCS1002 will heat up along each load line as voltage decreases. If the internal temperature exceeds the T_{REG} or T_{TSD} thresholds, the port power switch will open. Also note that when the VBUS voltage is brought low enough (below V_{BUS_MIN}), the port power switch will open.

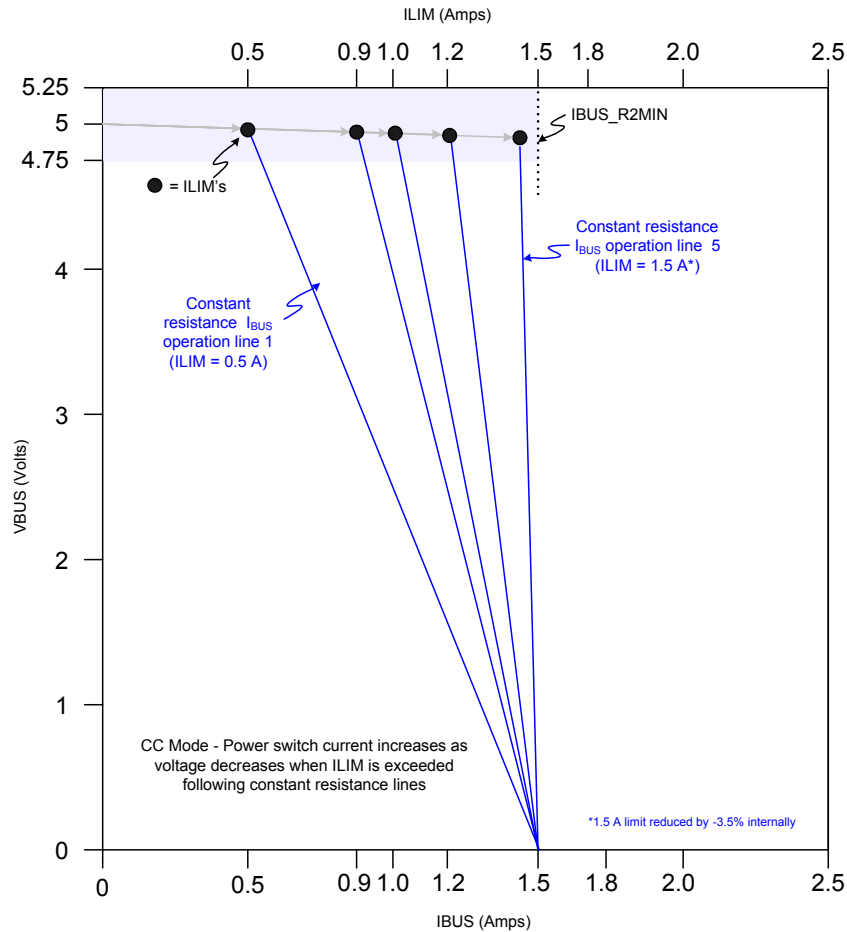

Figure 7.2 Constant Current Limiting (Variable Slope) Operation

7.3 Thermal Management and Voltage Protection

7.3.1 Thermal Management

The UCS1002 utilizes two-stage internal thermal management. The first is named dynamic thermal management and the second is a fixed thermal shutdown.

7.3.1.1 Dynamic Thermal Management

For the first stage (active in both current limiting modes), referred to as dynamic thermal management, the UCS1002 automatically adjusts port power switch limits and modes to lower power dissipation when the thermal regulation temperature value is approached, as described below.

If the internal temperature exceeds the T_{REG} value, the port power switch is opened, the current limit (ILIM) will be lowered by one step and a timer is started (t_{DC_TEMP}). When this timer expires, the port power switch is closed and the internal temperature will be checked again. If it remains above the T_{REG} threshold, the UCS1002 will repeat this cycle (open port power switch and reduce the ILIM setting by one step) until ILIM reaches its minimum value.

APPLICATION NOTE: If the temperature exceeds the TREG threshold while operating in the DCE Cycle mode after a charger emulation profile has been accepted, the profile will be removed. The UCS1002 will not restart the DCE Cycle until one of the control inputs changes states to restart emulation.

APPLICATION NOTE: The UCS1002 will not actively discharge VBUS as a result of the temperature exceeding TREG; however, any load current provided by a portable device or other load will cause VBUS to be discharged when the port power switch is opened, possibly resulting in an attached portable device resetting.

If the UCS1002 is operating using constant current limiting (variable slope) and the ILIM setting has been reduced to its minimum set point and the temperature is still above T_{REG} , the UCS1002 will switch to operating using trip current limiting. This will be done by reducing the I_{BUS_R2MIN} setting to 100 mA and restoring the ILIM setting to the value immediately below the programmed setting (e.g., if the programmed ILIM is 1.8 A, the value will be set to 1.5 A). If the temperature continues to remain above T_{REG} , the UCS1002 will continue this cycle (open the port power switch and reduce the ILIM setting by one step).

If the UCS1002 internal temperature drops below $T_{REG} - T_{REG_HYST}$, the UCS1002 will take action based on the following:

1. If the current limit mode changed from CC mode to trip mode, then a timer is started. When this timer expires, the UCS1002 will reset the port power switch operation to its original configuration allowing it to operate using constant current limiting (variable slope).
2. If the current limit mode did not change from CC mode to trip mode, or was already operating in trip mode, the UCS1002 will reset the port power switch operation to its original configuration.

If the UCS1002 is operating using trip current limiting and the ILIM setting has been reduced to its minimum set point and the temperature is above T_{REG} , the port power switch will be closed and the current limit will be held at its minimum setting until the temperature drops below $T_{REG} - T_{REG_HYST}$.

7.3.1.2 Thermal Shutdown

The second stage thermal management consists of a hardware implemented thermal shutdown corresponding to the maximum allowable internal die temperature (T_{TSD}). If the internal temperature exceeds this value, the port power switch will immediately be turned off until the temperature is below $T_{TSD} - T_{TSD_HYST}$.

7.4 VBUS Discharge

The UCS1002 will discharge V_{BUS} through an internal $100\ \Omega$ resistor when at least one of the following conditions occurs:

- The PWR_EN control is disabled (triggered on the inactive edge of the PWR_EN control).
- A portable device Removal Detection event is flagged.
- The VS voltage drops below a specified threshold (V_{S_UVLO}) that causes the port power switch to be disabled.
- When commanded into the Sleep power state via the EM_EN, M1, and M2 controls.
- Before each charger emulation profile is applied.
- Upon recovery from the Error state.
- When commanded via the SMBus (see [Section 10.4, "Configuration Registers"](#)) in the Active state.
- Any time that the port power switch is activated after the VBUS bypass switch has been on (i.e., whenever VBUS voltage transitions from being driven from VDD to being driven from VS, such as going from Detect to Active power state).
- Any time that the VBUS bypass switch is activated after the port power switch has been on (i.e., going from Active to Detect power state).

When the VBUS discharge circuitry is activated, at the end of the $t_{DISCHARGE}$ time, the UCS1002 will confirm that VBUS was discharged. If the VBUS voltage is not below the V_{TEST} level, a discharge error will be flagged (by setting the DISCHARGE_ERR status bit) and the UCS1002 will enter the Error state.

7.5 Battery Full

Delivery of bus current to a portable device can be rationed by the UCS1002. When this functionality is enabled, the host system must provide the UCS1002 with an accumulated charge maximum limit (in milliampere-hours). The charge rationing functionality works only in the Active power state. It continuously monitors the current delivered as well as the time elapsed since the mode was activated (or since the data was updated). This information is compiled to generate a charge-rationing number that is checked against the host limit.

Once the programmed current-rationing limit has been reached, the UCS1002 will take action as determined by the RATION_BEH bits as described in [Table 7.1](#). Note that this does not cause the device to enter the Error state.

Once the charge rationing circuitry has reached the programmed threshold, the UCS1002 will maintain the desired behavior until charge rationing is reset. Once charge rationing has been reset or disabled, the UCS1002 will recover as shown in [Table 7.2](#).

Table 7.1 Charge Rationing Behavior

RATION_BEH [1:0]		BEHAVIOR	ACTIONS TAKEN	NOTES
1	0			
0	0	Report	ALERT# pin asserted.	
0	1	Report and Disconnect (default)	<ol style="list-style-type: none"> 1. ALERT# pin asserted. 2. Charger emulation profile removed. 3. Port power switch disconnected. 	The HSW will not be affected. All bus monitoring is still active. Changing the M1, M2, EM_EN, S0, and PWR_EN controls will cause the device to change power states as defined by the pin combinations; however, the port power switch will remain off until the rationing circuitry is reset. Furthermore, the bypass switch will not be turned on if enabled via the S0 control.
1	0	Disconnect and go to Sleep	<ol style="list-style-type: none"> 1. Port power switch disconnected. 2. Charger emulation profile removed. 3. Device will enter the Sleep state. 	The HSW will be disabled. All VBUS and VS monitoring will be stopped. Changing the M1, M2, EM_EN, S0, and PWR_EN controls will have no effect on the power state until the rationing circuitry is reset.
1	1	Ignore	Take no further action.	

Table 7.2 Charge Rationing Reset Behavior

BEHAVIOR	RESET ACTIONS
Report	<ol style="list-style-type: none"> 1. Reset the Total Accumulated Charge registers. 2. Clear the RATION status bit. 3. Release the ALERT# pin.
Report and Disconnect	<ol style="list-style-type: none"> 1. Reset the Total Accumulated Charge registers. 2. Clear the RATION status bit. 3. Release the ALERT# pin. 4. Check the M1, M2, EM_EN, S0, and PWR_EN controls and enter the indicated power state if the controls changed (see Note 7.1).
Disconnect and go to Sleep	<ol style="list-style-type: none"> 1. Reset the Total Accumulated Charge registers. 2. Clear the RATION status bit. 3. Check the M1, M2, EM_EN, S0, and PWR_EN controls and enter the indicated power state if the controls changed (see Note 7.1).
Ignore	<ol style="list-style-type: none"> 1. Reset the Total Accumulated Charge registers. 2. Clear the RATION status bit.

Note 7.1 Any time the charge rationing circuitry checks the pin conditions when changing rationing behavior or resetting charge rationing, if the external pin conditions have changed, then charger emulation will be restarted (provided emulation is enabled via the pin states). If the pin conditions have not changed, the UCS1002 return to the previous power state as if the rationing threshold had not been reached (e.g., it will not discharge VBUS or restart emulation).

7.5.1 Charge Rationing Interactions

When charge rationing is active, regardless of the specified behavior, the UCS1002 will function normally until the charge rationing threshold is reached. Note that charge rationing is only active when the UCS1002 is in the Active state, and it does not automatically reset when a Removal or Attach Detection event occurs. Charger emulation will start over if a Removal Detection event and Attach Detection event occur while charge rationing is active and the charge rationing threshold has not been reached. This allows charging of sequential portable devices while charge is being rationed, which means that the accumulated power given to several portable devices will still be held to the stated rationing limit.

Changing the charge rationing behavior will have no effect on the charge rationing data registers. If the behavior is changed prior to reaching the charge rationing threshold, this change will occur and be transparent to the user. When the charge rationing threshold is reached, the UCS1002 will take action as shown in [Table 7.1](#). If the behavior is changed after the charge rationing threshold has been reached, the UCS1002 will immediately adopt the newly programmed behavior, clearing the ALERT# pin and restoring switch operation respectively (see [Table 7.3](#)).

Table 7.3 Effects of Changing Rationing Behavior after Threshold Reached

PREVIOUS BEHAVIOR	NEW BEHAVIOR	ACTIONS TAKEN
Ignore	Report	Assert ALERT# pin.
	Report and Disconnect	<ol style="list-style-type: none"> 1. Assert ALERT# pin. 2. Remove charger emulation profile. 3. Open port power switch. See the “Report and Disconnect” entry in Table 7.1.
	Disconnect and go to Sleep	<ol style="list-style-type: none"> 1. Remove charger emulation profile. 2. Open port power switch. 3. Enter the Sleep state. See the “Disconnect and go to Sleep” entry in Table 7.1.
Report	Ignore	Release ALERT# pin.
	Report and Disconnect	Open port power switch. See the “Report and Disconnect” entry in Table 7.1 .
	Disconnect and go to Sleep	<ol style="list-style-type: none"> 1. Release the ALERT# pin. 2. Remove charger emulation profile. 3. Open the port power switch. 4. Enter the Sleep state. See the “Disconnect and go to Sleep” entry in Table 7.1.

Table 7.3 Effects of Changing Rationing Behavior after Threshold Reached (continued)

PREVIOUS BEHAVIOR	NEW BEHAVIOR	ACTIONS TAKEN
Report and Disconnect	Ignore	<ol style="list-style-type: none"> 1. Release the ALERT# pin. 2. Check the M1, M2, EM_EN, S0, and PWR_EN controls and enter the indicated power state if the controls changed (see Note 7.1).
	Report	Check the M1, M2, EM_EN, S0, and PWR_EN controls and enter the indicated power state if the controls changed (see Note 7.1).
	Disconnect and go to Sleep	<ol style="list-style-type: none"> 1. Release the ALERT# pin. 2. Enter the Sleep state. See the “Disconnect and go to Sleep” entry in Table 7.1.
Disconnect and go to Sleep	Ignore	Check the M1, M2, EM_EN, S0, and PWR_EN controls and enter the indicated power state if the controls changed (see Note 7.1).
	Report	<ol style="list-style-type: none"> 1. Assert the ALERT# pin. 2. Check the M1, M2, EM_EN, S0, and PWR_EN controls and enter the indicated power state if the controls changed (see Note 7.1).
	Report and Disconnect	<ol style="list-style-type: none"> 1. Assert the ALERT# pin. 2. Check the M1, M2, EM_EN, S0, and PWR_EN controls to determine the power state then enter that state except that the port power switch and bypass switch will not be closed (see Note 7.1).

If the RATION_EN control is set to '0' prior to reaching the charge rationing threshold, rationing will be disabled and the Total Accumulated Charge registers will be cleared. If the RATION_EN control is set to '0' after the charge rationing threshold has been reached, the following will be done:

1. RATION status bit will be cleared.
2. The ALERT# pin will be released if asserted by the rationing circuitry and no other conditions are present.
3. The M1, M2, EM_EN, S0, and PWR_EN controls are checked to determine the power state. See [Note 7.1](#).

APPLICATION NOTE: If the rationing behavior was set to “Report and Disconnect” when the charge rationing threshold was reached and then the RATION_EN bit is cleared, the portable device may start charging suboptimally because the charger emulation profile has been removed. Toggle the PWR_EN control to restart charger emulation.

Setting the RATION_RST control to '1' will automatically reset the Total Accumulated Charge registers to 00_00h. If this is done prior to reaching the charge rationing threshold, the data will continue to be accumulated restarting from 00_00h. If this is done after the charge rationing threshold is reached, the UCS1002 will take action as shown in [Table 7.2](#).

7.6 Fault Handling Mechanism

The UCS1002 has two modes for handling faults: Latch (latch-upon-fault) or Auto-recovery (automatically attempt to restore the Active power state after a fault occurs). If the SMBus is actively utilized, auto-recovery fault handling is the default error handler as determined by the LATCH_SET bit (see [Section 10.4.3, "Switch Configuration - 17h"](#)). Otherwise, the fault handling mechanism used depends on the state of the LATCH pin. Faults include over-current, over-voltage (on VS), under-

voltage (on VBUS), back-voltage (VBUS to VS or VBUS to VDD), discharge error, and maximum allowable internal die temperature (T_{TSD}) exceeded (see Section 5.1.5, "Error State Operation").

7.6.1 Auto-recovery Fault Handling

When the LATCH control is low, auto-recovery fault handling is used. When an error condition is detected, the UCS1002 will immediately enter the Error state and assert the ALERT# pin (see Section 5.1.5). Independently from the host controller, the UCS1002 will wait a preset time (t_{CYCLE}), check error conditions (t_{TST}), and restore Active operation if the error condition(s) no longer exist. If all other conditions that may cause the ALERT# pin to be asserted have been removed, the ALERT# pin will be released.

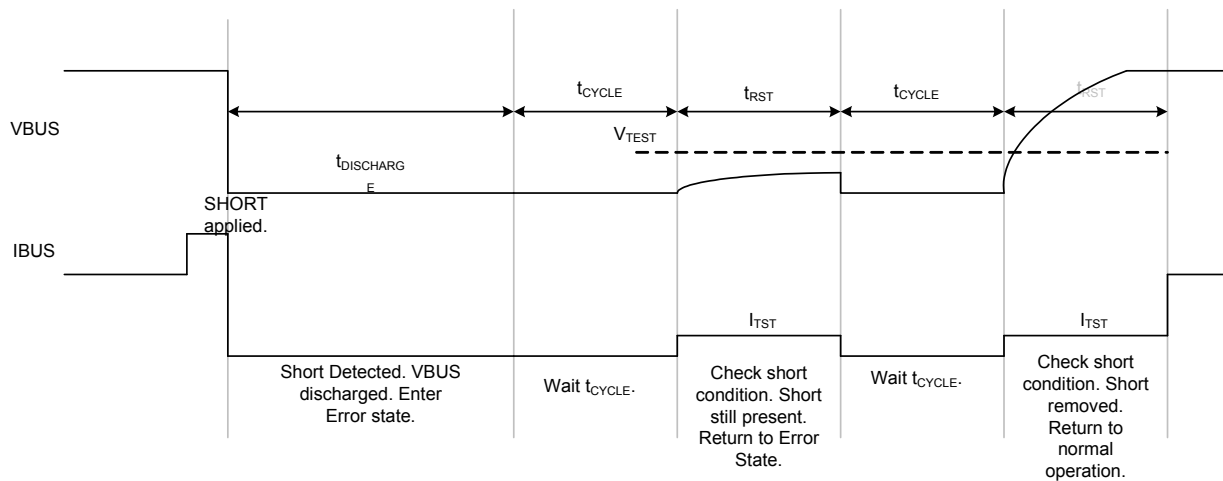

Figure 7.3 Error Recovery Timing (Short Circuit Example)

7.6.2 Latched Fault Handling

When the LATCH control is high, latch fault handling is used. When an error condition is detected, the UCS1002 will enter the Error power state and assert the ALERT# pin. Upon command from the host controller (by toggling the PWR_EN control from enabled to disabled or by clearing the ERR bit via SMBus), the UCS1002 will check error conditions once and restore Active operation if error conditions no longer exist. If an error condition still exists, the host controller is required to issue the command again to check error conditions.

Chapter 8 Detect State

8.1 Device Attach / Removal Detection

The UCS1002 can detect the attachment and removal of a portable device on the USB port. Attach and Removal Detection does not perform any charger emulation or qualification of the device. The high-speed switch is “off” (by default) during the Detect power state.

8.2 VBUS Bypass Switch

The UCS1002 contains circuitry to provide VBUS current as shown in [Figure 8.1](#). In the Detect state, VDD is the voltage source; in the Active state, VS is the voltage source. The bypass switch and the port power switch are never both on at the same time.

While the VBUS bypass switch is active, the current available to a portable device will be limited to I_{BUS_BYP} , and the Attach Detection feature is active.

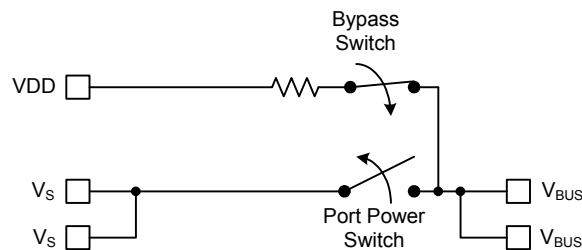

Figure 8.1 Detect State VBUS Biasing

8.3 Attach Detection

The Attach Detection feature is only active in the Detect power state. When active, this feature constantly monitors the current load on the VBUS pin. If the current drawn by a portable device is greater than I_{DET_QUAL} for longer than t_{DET_QUAL} , an Attach Detection event occurs. This will cause the A_DET# pin to assert low and the ADET_PIN and ATT status bits to be set.

Until the port power switch is enabled, the current available to a portable device will be limited to that used to detect device attachment (I_{DET_QUAL}). Once an Attach Detection event occurs, the UCS1002 will wait for the PWR_EN control to be enabled (if not already). When PWR_EN is enabled and VS is above the threshold, the UCS1002 will activate the USB port power switch and operate in the selected Active mode (see [Chapter 9, Active State](#)).

8.4 Removal Detection

The Removal Detection feature will be active in the Active and Detect power states if $S0 = 1$. This feature monitors the current load on the VBUS pin. If this load drops to less than $I_{REM_QUAL_DET}$ for longer than t_{REM_QUAL} , a Removal Detection event is flagged.

When a Removal Detection event is flagged, the following will be done:

1. Disable the port power switch and the bypass switch.

2. De-assert the A_DET# pinUCS1002 and set the REM status register bit.
3. Enable an internal discharging device that will discharge the VBUS line within $t_{DISCHARGE}$.
4. Once the VBUS pin has been discharged, the device will return to the Detect state regardless of the PWR_EN control state.

Chapter 9 Active State

9.1 Active State Overview

The UCS1002 has the following modes of operation in the Active state: Data Pass-through, BC1.2 DCP, BC1.2 SDP, BC1.2 CDP, and Dedicated Charger Emulation Cycle. The current limiting mode depends on the Active mode behavior (see [Table 9.2, "Current Limit Mode Options"](#)).

9.2 Active Mode Selection

The Active mode selection is controlled by three controls: EM_EN, M1, and M2, as shown in [Table 9.1](#).

Table 9.1 Active Mode Selection

#	M1	M2	EM_EN	ACTIVE MODE
1	0	0	1	Dedicated Charger Emulation Cycle
2	0	1	0	Data Pass-through
3	0	1	1	BC1.2 DCP
4	1	0	0	BC1.2 SDP - See Note 9.1
5	1	0	1	Dedicated Charger Emulation Cycle
6	1	1	0	Data Pass-through
7	1	1	1	BC1.2 CDP

Note 9.1 BC1.2 SDP behaves the same as the Data Pass-through mode with the exception that it is preceded by a VBUS discharge when the mode is entered per the BC1.2 specification.

9.3 BC1.2 Detection Renegotiation

The BC1.2 specification allows a charger to act as an SDP, CDP, or DCP and to change between these roles. To force an attached portable device to repeat the charging detection procedure, VBUS must be cycled. In compliance with this specification, the UCS1002 automatically cycles VBUS when switching between the BC1.2 SDP, BC1.2 DCP, and BC1.2 CDP modes.

9.4 Data Pass-through (No Charger Emulation)

When commanded to Data Pass-through mode, UCS1002 will close its USB high-speed data switch to allow USB communications between a portable device and host controller and will operate using trip current limiting. No charger emulation profiles are applied in this mode. Data Pass-through mode will persist until commanded otherwise by the M1, M2, and EM_EN controls.

APPLICATION NOTE: If it is desired that the Data Pass-through mode operates as a traditional / standard port power switch, the S0 control should be set to '0'. When entering this mode, there is no automatic VBUS discharge.

APPLICATION NOTE: When the M1, M2, and EM_EN controls are set to '0', '1', '0' or to '1', '1', '0' respectively, Data Pass-through mode will persist if the PWR_EN control is disabled; however, the UCS1002 will draw more current. To leave Data Pass-through mode, the PWR_EN control must be enabled before the M1, M2, and EM_EN controls are changed to the desired mode.

9.5 BC1.2 SDP (No Charger Emulation)

When commanded to BC1.2 SDP mode, UCS1002 will discharge VBUS, close its USB high-speed data switch to allow USB communications between a portable device and host controller, and will operate using trip current limiting. No charger emulation profiles are applied in this mode. BC1.2 SDP mode will persist until commanded otherwise by the M1, M2, EM_EN, and PWR_EN controls.

APPLICATION NOTE: If it is desired that the BC1.2 SDP mode operates as a traditional / standard port power switch, the S0 control should be set to '0'.

9.6 BC1.2 CDP

When BC1.2 CDP is selected as the Active mode, UCS1002 will discharge VBUS, close its USB high-speed data switch (by default), and apply the BC1.2 CDP charger emulation profile which performs handshaking per the specification. The combination of the UCS1002 CDP handshake along with a standard USB host comprises a charging downstream port. In BC1.2 CDP mode, there is no emulation timeout.

If the handshake is successful, the UCS1002 will operate using constant current limiting (variable slope). If the handshake is not successful, the UCS1002 will leave the applied CDP profile in place, leave the high-speed switch closed, enable constant current limiting, and persist in this condition until commanded otherwise by the M1, M2, EM_EN, and PWR_EN controls.

The UCS1002 will respond per the BC1.2 specification to portable device initiated charger renegotiation requests.

APPLICATION NOTE: BC1.2 compliance testing may require the S0 control to be set to '0' (Attach and Removal Detection feature disabled) while testing is in progress.

APPLICATION NOTE: When the UCS1002 is in BC1.2 CDP mode and the Attach and Removal Detection feature is enabled, if a power thief, such as a USB light or fan, attaches but does not assert DP, a Removal event will not occur when the portable device is removed. However, if a standard USB device is subsequently attached, Removal Detection will again be fully functional. As well, if PWR_EN is cycled or M1, M2, and / or EM_EN change state, a Removal event will occur and Attach Detection will be reactivated.

9.6.1 BC1.2 CDP Charger Emulation Profile

The BC1.2 CDP charger emulation profile acts as described below.

APPLICATION NOTE: All CDP handshaking is performed with the high-speed switch closed.

1. VBUS voltage is applied.
2. Primary Detection - When the portable device drives a voltage between 0.4 V and 0.8 V onto the DPOUT pin, the UCS1002 will drive 0.6 V onto the DMOUT pin within 20 ms.
3. When the portable device drives the DPOUT pin back to '0', the UCS1002 will then drive the DMOUT pin back to '0' within 20 ms.

- Optional Secondary Detection - If the portable device then drives a voltage of 0.6 V (nominal) onto the DMOUT pin, the UCS1002 will take no other action. This will cause the portable device to observe a '0' on the DPOUT pin and know that it is connected to a CDP.

9.7 BC1.2 DCP

When BC1.2 DCP is selected as the Active mode, UCS1002 will discharge VBUS and apply the BC1.2 DCP charger emulation profile per the specification. In BC1.2 DCP mode, the emulation timeout and requirement for portable device current draw are automatically disabled. When the BC1.2 DCP charger emulation profile is applied within the Dedicated Charger Emulation Cycle (see [Section 9.11.1, "BC1.2 DCP Charger Emulation Profile Within DCE Cycle"](#)), the timeout and current draw requirement are enabled.

If the portable device is charging after the DCP charger emulation profile is applied, the UCS1002 will leave in place the resistive short, leave the high-speed switch open, and enable constant current limiting (variable slope).

APPLICATION NOTE: BC1.2 compliance testing may require the S0 control to be set to '0' (Attach and Removal Detection feature disabled) while testing is in progress.

9.7.1 BC1.2 DCP Charger Emulation Profile

The BC1.2 DCP charger emulation profile is described below.

- VBUS voltage is applied. A resistor (R_{DCP_RES}) is connected between the DPOUT and DMOUT pins.
- Primary Detection - If the portable device drives 0.6 V (nominal) onto the DPOUT pin, the UCS1002 will take no other action than to leave the resistor connected between DPOUT and DMOUT. This will cause the portable device to see 0.6 V (nominal) on the DMOUT pin and know that it is connected to a DCP.
- Optional Secondary Detection - If the portable device drives 0.6 V (nominal) onto the DMOUT pin, the UCS1002 will take no other action than to leave the resistor connected between DPOUT and DMOUT. This will cause the portable device to see 0.6 V (nominal) on the DPOUT pin and know that it is connected to a DCP.

9.8 Dedicated Charger

When commanded to Dedicated Charger Emulation Cycle mode, the UCS1002 enables an attached portable device to enter its charging mode by applying specific charger emulation profiles in a predefined sequence. Using these profiles, the UCS1002 is capable of generating and recognizing several signal levels on the DPOUT and DMOUT pins. The preloaded charger emulation profiles include ones compatible with BC1.2 DCP, YD/T-1591 (2009) and most Apple and RIM portable devices. Other levels, sequences, and protocols are configurable via the SMBus / I²C.

When a charger emulation profile is applied, a programmable timer for the emulation profile is started. When emulation timeout occurs, the UCS1002 checks the IBUS current against a programmable threshold. If the current is above the threshold, the charger emulation profile is accepted and the associated current limiting mode is applied. No active USB data communication is possible when charging in this mode (by default - see [Section 10.4.5, "High-speed Switch Configuration - 25h"](#)).

9.8.1 Emulation Reset

Prior to applying any of the charger emulation profiles, the UCS1002 will perform an emulation reset. This involves the following:

1. The UCS1002 resets the VBUS line by disconnecting the port power switch and connecting VBUS to ground via an internal 100 Ω resistor for $t_{DISCHARGE}$ time. The port power switch will be held open for a time equal to t_{EM_RESET} at which point the port power switch will be closed and the VBUS voltage applied.
2. The DPOUT and DMOUT pins will be pulled low using internal 15 k Ω pull-down resistors.

APPLICATION NOTE: To help prevent possible damage to a portable device, the DPOUT and DMOUT pins have current limiting in place when the emulation profiles are applied.

9.8.2 Emulation Cycling

In Dedicated Charger Emulation Cycle mode, the charger emulation profiles (if enabled) will be applied in the following order:

1. Legacy 1
2. BC1.2 DCP
3. Legacy 2
4. Legacy 3
5. Legacy 4
6. Legacy 5
7. Legacy 6
8. Legacy 7
9. Custom (disabled by default). If the CS1_FIRST configuration bit is set, then the Custom charger emulation profile will be tested first and the order will proceed as given.

APPLICATION NOTE: If S0='0' and a portable device is not attached in DCE Cycle mode, the UCS1002 will be cycling through charger emulation profiles (by default). There is no guarantee which charger emulation profile will be applied first when a portable device attaches.

The UCS1002 will apply a charger emulation profile until one of the following exit conditions occurs:

1. Current greater than I_{BUS_CHG} is detected flowing out of VBUS at the respective emulation timeout time. In this case, the profile is assumed to be accepted and no other profiles will be applied.
2. The respective emulation timeout ($t_{EM_TIMEOUT}$) time is reached without current that exceeds the I_{BUS_CHG} limit flowing out of VBUS (the emulation timeout is enabled by default, see [Section 10.4.2, "Emulation Configuration - 16h"](#) and [Section 10.13.1, "Custom Emulation Configuration - 40h"](#)). The profile is assumed to be rejected, and the UCS1002 will perform emulation reset and apply the next profile, if there is one.

Emulation timeouts can be programmed for each charger emulation profile (see [Section 10.11, "Preloaded Emulation Timeout Configuration Registers"](#) and [Section 10.13.1, "Custom Emulation Configuration - 40h"](#)).

9.8.3 DCE Cycle Retry

If none of the charger emulation profiles cause a charge current to be drawn, the UCS1002 will perform emulation reset and cycle through the profiles again (if the EM_RETRY bit is set (default - see [Section 10.4.2, "Emulation Configuration - 16h"](#))). The UCS1002 will continue to cycle through the profiles so as long as charging current is not drawn and the PWR_EN control is enabled. If the Emulation Retry is not enabled, the UCS1002 will flag "no handshake" and end the DCE Cycle using trip current limiting.

9.9 Current Limit Mode Associations

The UCS1002 will close the port power switch and use the current limiting mode as shown in [Table 9.2](#).

Table 9.2 Current Limit Mode Options

ACTIVE MODE	CURRENT LIMIT MODE (SEE Section 10.14)
Data Pass-through	Trip mode
BC1.2 DCP	CC mode if $ILIM \leq 1.5$ A, otherwise, trip mode
BC1.2 SDP	Trip mode
BC1.2 CDP	CC mode if $ILIM \leq 1.5$ A, otherwise, trip mode
DCE CYCLE	
During DCE Cycle when a charger emulation profile is being applied and the emulation timeout is active	CC mode if $ILIM \leq 1.5$ A, otherwise, trip mode
BC1.2 DCP charger emulation profile accepted or the emulation timeout is disabled	CC mode if $ILIM \leq 1.5$ A, otherwise, trip mode
Legacy 2 charger emulation profile accepted or the emulation timeout is disabled	CC mode if $ILIM \leq 1.5$ A, otherwise, trip mode
Legacy 1 or Legacy 3 - Legacy 7 charger emulation profile accepted or the emulation timeout is disabled	Trip mode if $I_{BUS_R2MIN} \leq ILIM$ or $ILIM > 1.5$ A (normal operation), otherwise, CC mode (see Section 10.14.2)
Custom charger emulation profile accepted or the emulation timeout is disabled	Trip mode if $I_{BUS_R2MIN} \leq ILIM$ or $ILIM > 1.5$ A (normal operation), otherwise, CC mode (see Section 10.14.2)
No handshake (DCE Cycle with Emulation Retry not enabled)	Trip mode if $I_{BUS_R2MIN} \leq ILIM$ or $ILIM > 1.5$ A (normal operation), otherwise, CC mode (see Section 10.14.2)

As noted in the last three rows in [Table 9.2](#), under those specific conditions with $ILIM \leq 1.5$ A, it is the relationship of $ILIM$ and I_{BUS_R2MIN} that determines the current limiting mode. In these cases, the value of I_{BUS_R2MIN} is determined by CS_R2_IMIN[2:0] bits 4-2 in the Custom Current Limiting Behavior Configuration register 51h.

9.10 No Handshake

In DCE Cycle mode with emulation retry disabled, a “no handshake” condition is flagged (the NO_HS status bit stays set (see [Section 10.3.4, "Profile Status 1 - 12h"](#))) when the end of the DCE Cycle is reached without a handshake and without drawing current.

All signatures / handshaking placed on the DPOUT and DMOUT pins are removed. The UCS1002 will operate with the high-speed switch opened or closed as determined by the high-speed switch configuration and will use trip or constant current limiting as determined by the I_{BUS_R2MIN} setting (CS_R2_IMIN[2:0] bits 4-2 in the Custom Current Limiting Behavior Configuration register 51h).

Portable devices that can cause this are generally ones that pull up DPOUT to some voltage and leave it there, or apply the wrong voltage.

9.11 Preloaded Charger Emulation Profiles

The following charger emulation profiles are resident to the UCS1002:

1. Legacy 1, 3, 4, and 6 - See [Section 9.11.3](#)
2. Legacy 2 - See [Section 9.11.2](#)
3. Legacy 5 - See [Section 9.11.4](#)
4. Legacy 7 - See [Section 9.11.5](#)
5. BC1.2 CDP - See [Section 9.6.1](#)
6. BC1.2 DCP - See [Section 9.7.1](#)

Additionally, the user may “build” a charger emulation profile by determining the voltage and resistance characteristics that are placed on each of the DPOUT and DMOUT pins. See [Section 9.12, "Custom Charger Emulation Profile"](#).

9.11.1 BC1.2 DCP Charger Emulation Profile Within DCE Cycle

When the BC1.2 DCP charger emulation profile ([Section 9.7.1, "BC1.2 DCP Charger Emulation Profile"](#)) is applied within the DCE Cycle (Dedicated Charger Emulation Cycle is selected as the Active mode), the behavior after the profile is applied is different than Active mode BC1.2 DCP (BC1.2 DCP in [Table 9.1](#)) because the $t_{EM_TIMEOUT}$ timer is enabled (by default) during the DCE Cycle.

During the DCE Cycle after the DCP charger emulation profile, the UCS1002 will perform one of the following:

1. If the portable device is drawing more than I_{BUS_CHG} current when the $t_{EM_TIMEOUT}$ timer expires, the UCS1002 will flag that a BC1.2 DCP was detected. The UCS1002 will leave in place the resistive short, leave the high-speed switch open, and then enable constant current limiting (variable slope).
2. If the portable device does not draw more than I_{BUS_CHG} current when the $t_{EM_TIMEOUT}$ timer expires, the UCS1002 will stop applying the DCP charger emulation profile and proceed to the next charger emulation profile in the DCE Cycle.

9.11.2 Legacy 2 Charger Emulation Profile

The Legacy 2 charger emulation profile does the following:

1. The UCS1002 will connect a resistor (R_{DCP_RES}) between DPOUT and DMOUT.
2. VBUS is applied.
3. If the portable device draws more than I_{BUS_CHG} current when the $t_{EM_TIMEOUT}$ timer expires (enabled by default), the UCS1002 will accept that this is the correct charger emulation profile for the attached portable device. Charging commences. The resistive short between the DPOUT and DMOUT pins will be left in place. The UCS1002 will use constant current limiting.
4. If the portable device does not draw more than I_{BUS_CHG} current when $t_{EM_TIMEOUT}$ timer expires, the UCS1002 will stop the Legacy 2 charger emulation. This will cause resistive short between the DPOUT and DMOUT pins to be removed. Emulation reset occurs, and the UCS1002 will initiate the next charger emulation profile.

9.11.3 Legacy 1, 3, 4, and 6 Charger Emulation Profiles

Legacy 1, 3, 4, and 6 charger emulation profiles follow the same pattern of operation although the voltage that is applied on the DPOUT and DMOUT pins will vary. They do the following:

1. The UCS1002 will apply a voltage on the DPOUT pin using either a current-limited voltage source or a voltage divider between VBUS and ground with the center tap on the DPOUT pin.
2. The UCS1002 will apply a possibly different voltage on the DMOUT pin using either a current-limited voltage source or a voltage divider between VBUS and ground with the center tap on the DMOUT pin.
3. VBUS voltage is applied.
4. If the portable device draws more than I_{BUS_CHG} current when the $t_{EM_TIMEOUT}$ timer expires, the UCS1002 will accept that the currently applied profile is the correct charger emulation profile for the attached portable device. Charging commences. The voltages applied to the DPOUT and DMOUT pins will remain in place (unless LEAVE_EMU_RESP is set to 0b). The UCS1002 will begin operating in trip mode or CC mode as determined by the I_{BUS_R2MIN} setting (see [Section 10.14, "Current Limiting Behavior Configuration Registers"](#)).
5. If the portable device does not draw more than I_{BUS_CHG} current when $t_{EM_TIMEOUT}$ timer expires, the UCS1002 will stop the currently applied charger emulation profile. This will cause all voltages put onto the DPOUT and DMOUT pins to be removed. Emulation reset occurs, and the UCS1002 will initiate the next charger emulation profile.

9.11.4 Legacy 5 Charger Emulation Profile

Legacy 5 charger emulation profile does the following:

1. The UCS1002 will apply 900 mV to both the DPOUT and the DMOUT pins.
2. VBUS voltage is applied.
3. If the portable device draws more than I_{BUS_CHG} current when the $t_{EM_TIMEOUT}$ timer expires, the UCS1002 will accept that the currently applied profile is the correct charger emulation profile for the attached portable device. Charging commences. The voltages applied to the DPOUT and DMOUT pins will remain in place (unless LEAVE_EMU_RESP is set to 0b). The UCS1002 will begin operating in trip mode or CC mode as determined by the I_{BUS_R2MIN} setting (see [Section 10.14, "Current Limiting Behavior Configuration Registers"](#)).
4. If the portable device does not draw more than I_{BUS_CHG} current when $t_{EM_TIMEOUT}$ timer expires, the UCS1002 will stop the currently applied charger emulation profile. This will cause all voltages put onto the DPOUT and DMOUT pins to be removed. Emulation reset occurs, and the UCS1002 will initiate the next charger emulation profile.

9.11.5 Legacy 7 Charger Emulation Profile

The Legacy 7 charger emulation profile does the following:

1. The UCS1002 will apply a voltage on the DPOUT pin using a voltage divider between VBUS and ground with the center tap on the DPOUT pin.
2. VBUS voltage is applied.
3. If the portable device draws more than I_{BUS_CHG} current when the $t_{EM_TIMEOUT}$ timer expires, the UCS1002 will accept that Legacy 7 is the correct charger emulation profile for the attached portable device. Charging commences. The voltage applied to the DPOUT pin will remain in place (unless LEAVE_EMU_RESP is set to 0b). The UCS1002 will begin operating in trip mode or CC mode as determined by the I_{BUS_R2MIN} setting (see [Section 10.14, "Current Limiting Behavior Configuration Registers"](#)).

4. If the portable device does not draw more than I_{BUS_CHG} current when $t_{EM_TIMEOUT}$ timer expires, the UCS1002 will stop the Legacy 7 charger emulation profile. This will cause the voltage put onto the DPOUT pin to be removed. Emulation reset occurs, and the UCS1002 will initiate the next charger emulation profile.

9.12 Custom Charger Emulation Profile

The UCS1002 allows the user to create a Custom charger emulation profile to handshake as any type of charger. This profile can be included in the DCE Cycle. In addition, it can be placed first or last in the profile sequence in the DCE Cycle. See [Section 10.13.1, "Custom Emulation Configuration - 40h"](#).

The Custom charger emulation profile uses a number of registers to define stimuli and behaviors. The Custom charger emulation profile uses three separate stimulus / response pairs that will be detected and applied in sequence, allowing flexibility to “build” any of the preloaded emulation profiles or tailor the profile to match a specific charger application.

For details, see application note 24.14 “UCS1002 Fundamentals of Custom Charger Emulation.

Chapter 10 Register Description

The registers shown in [Table 10.1](#) are accessible through the SMBus or I²C. An entry of ‘-’ indicates that the bit is not used. Writing to these bits will have no effect and reading these bits will return ‘0’. An entry of RES indicates that the bit is reserved. Writing to a RES bit may cause unexpected results and reading from a RES bit will return either ‘1’ or ‘0’ as indicated in the bit description. While in the Sleep state, the UCS1002 will retain configuration and charge rationing data as indicated in the text. If a register does not indicate that data will be retained in the Sleep power state, this information will be lost when the UCS1002 enters the Sleep power state.

Table 10.1 Register Set in Hexadecimal Order

REGISTER ADDRESS	R/W	REGISTER NAME	FUNCTION	DEFAULT VALUE	PAGE
00h	R	Current Measurement	Stores the current measurement	00h	Page 71
01h	R	Total Accumulated Charge High Byte	Stores the total accumulated charge delivered high byte	00h	Page 72
02h	R	Total Accumulated Charge Middle High Byte	Stores the total accumulated charge delivered middle high byte	00h	Page 72
03h	R	Total Accumulated Charge Middle Low Byte	Stores the total accumulated charge delivered middle low byte	00h	Page 72
04h	R	Total Accumulated Charge Low Byte	Stores the total accumulated charge delivered low byte	00h	Page 72
0Fh	R	Other Status	Indicates emulation status as well as the ALERT# and A_DET# pin status	00h	Page 73
10h	See Text	Interrupt Status	Indicates why ALERT# pin asserted.	00h	Page 73
11h	R / R-C	General Status	Indicates general status	00h	Page 73
12h	R	Profile Status 1	Indicates which charger emulation profile was accepted	00h	Page 73
13h	R	Profile Status 2		00h	Page 73
14h	R	Pin Status	Indicates the pin states of the internal control pins	00h	Page 73
15h	R/W	General Configuration	Controls basic functionality	01h	Page 78
16h	R/W	Emulation Configuration	Controls emulation functionality	8Ch	Page 78
17h	R/W	Switch Configuration	Controls advanced switch functions	04h	Page 78
18h	R/W	Attach Detect Configuration	Controls Attach Detect functionality	46h	Page 78

Table 10.1 Register Set in Hexadecimal Order (continued)

REGISTER ADDRESS	R/W	REGISTER NAME	FUNCTION	DEFAULT VALUE	PAGE
19h	R/W	Current Limit	Controls the maximum current limit	00h	Page 82
1Ah	R/W	Charge Rationing Threshold High Byte	Controls the Current Threshold I_{THRESH} used by the charge rationing circuitry	FFh	Page 83
1Bh	R/W	Charge Rationing Threshold Low Byte	Controls the Current Threshold I_{THRESH} used by the charge rationing circuitry	FFh	Page 83
1Ch	R/W	Auto-recovery Configuration	Controls the Auto-recovery functionality	2Ah	Page 84
1Eh	R/W	IBUS_CHG Configuration	Stores the limit for I_{BUS_CHG} used to determine if emulation is successful	04h	Page 85
1Fh	R/W	tDET_CHARGE Configuration	Stores bits that define the tDET_CHARGE time	03h	Page 85
20h	R/W	BCS Emulation Enable	Enables BCS charger emulation profiles	06h	Page 87
21h	R/W	Legacy Emulation Enable	Enables Legacy charger emulation profiles	00h	Page 87
22h	R/W	BCS Emulation Timeout Config	Controls timeout for each BCS charger emulation profile	10h	Page 88
23h	R/W	Legacy Emulation Timeout Config 1	Controls timeout for Legacy charger emulation profiles 1 - 4	B0h	Page 88
24h	R/W	Legacy Emulation Timeout Config 2	Controls timeout for Legacy charger emulation profiles 5 - 7	04h	Page 88
25h	R/W	High-speed Switch Configuration	Controls when the high-speed switch is enabled	14h	Page 78
30h	R	Applied Charger Emulation	Indicates which charger emulation profile is being applied	00h	Page 90
31h	R	Preloaded Emulation Stimulus 1 - Config 1	Indicates the stimulus and timing for stimulus 1	00h	Page 90
32h	R	Preloaded Emulation Stimulus 1 - Config 2	Indicates the response and magnitude for stimulus 1	00h	Page 90
33h	R	Preloaded Emulation Stimulus 1 - Config 3	Indicates the threshold and pull-up / pull-down settings for stimulus 1	00h	Page 90
34h	R	Preloaded Emulation Stimulus 1 - Config 4	Indicates the resistor ratio for stimulus 1	00h	Page 90
35h	R	Preloaded Emulation Stimulus 2 - Config 1	Indicates the stimulus and timing for stimulus 2	00h	Page 90
36h	R	Preloaded Emulation Stimulus 2 - Config 2	Indicates the response and magnitude for stimulus 2	00h	Page 90

Table 10.1 Register Set in Hexadecimal Order (continued)

REGISTER ADDRESS	R/W	REGISTER NAME	FUNCTION	DEFAULT VALUE	PAGE
37h	R	Preloaded Emulation Stimulus 2 - Config 3	Indicates the threshold and pull-up / pull-down settings for stimulus 2	00h	Page 90
38h	R	Preloaded Emulation Stimulus 2 - Config 4	Indicates the resistor ratio for stimulus 2	00h	Page 90
39h	R	Preloaded Emulation Stimulus 3 - Config 1	Indicates the stimulus and timing for stimulus 3 (CDP only)	00h	Page 90
3Ah	R	Preloaded Emulation Stimulus 3 - Config 2	Indicates the response and magnitude for stimulus 3 (CDP only)	00h	Page 90
3Bh	R	Preloaded Emulation Stimulus 3 - Config 3	Indicates the threshold and pull-up / pull-down settings for stimulus 3 (CDP only)	00h	Page 90
40h	R/W	Custom Emulation Config	Controls general configuration of the Custom charger emulation profile	01h	Page 99
41h	R/W	Custom Stimulus / Response Pair 1 - Config 1	Sets the stimulus and timing for stimulus 1	00h	Page 99
42h	R/W	Custom Stimulus / Response Pair 1 - Config 2	Sets the response and magnitude for stimulus 1	00h	Page 99
43h	R/W	Custom Stimulus / Response Pair 1 - Config 3	Sets the threshold and pull-up / pull-down settings for stimulus 1	00h	Page 99
44h	R/W	Custom Stimulus / Response Pair 1 - Config 4	Sets the resistor ratio for stimulus 1	00h	Page 99
45h	R/W	Custom Stimulus / Response Pair 2 - Config 1	Sets the stimulus and timing for stimulus 2	00h	Page 99
46h	R/W	Custom Stimulus / Response Pair 2 - Config 2	Sets the response and magnitude for stimulus 2	00h	Page 99
47h	R/W	Custom Stimulus / Response Pair 2 - Config 3	Sets the threshold and pull-up / pull-down settings for stimulus 2	00h	Page 99
48h	R/W	Custom Stimulus / Response Pair 2 - Config 4	Sets the resistor ratio for stimulus 2	00h	Page 99
49h	R/W	Custom Emulation Stimulus 3 - Config 1	Sets the stimulus and timing for stimulus 3	00h	Page 99

Table 10.1 Register Set in Hexadecimal Order (continued)

REGISTER ADDRESS	R/W	REGISTER NAME	FUNCTION	DEFAULT VALUE	PAGE
4Ah	R/W	Custom Stimulus / Response Pair 3 - Config 2	Sets the response and magnitude for stimulus 3	00h	Page 99
4Bh	R/W	Custom Stimulus / Response Pair 3 - Config 3	Sets the threshold and pull-up / pull-down settings for stimulus 3	00h	Page 99
4Ch	R/W	Custom Stimulus / Response Pair 3 - Config 4	Sets the resistor ratio for stimulus 3	00h	Page 99
50h	R	Applied Current Limiting Behavior	Indicates the applied current limiting behavior	82h	Page 102
51h	R/W	Custom Current Limiting Behavior Config	Controls the custom current limiting behavior	82h	Page 102
FDh	R	Product ID	Stores a fixed value that identifies each product	4Eh	Page 103
FEh	R	Manufacturer ID	Stores a fixed value that identifies SMSC	5Dh	Page 104
FFh	R	Revision	Stores a fixed value that represents the revision number	82h	Page 104

During power-on reset (POR), the default values are stored in the registers. A POR is initiated when power is first applied to the part and the voltage on the VDD supply surpasses the V_{DD_TH} level as specified in the electrical characteristics. Any reads to undefined registers will return 00h. Writes to undefined registers will not have an effect.

When a bit is “set”, this means that the user writes a logic ‘1’ to it. When a bit is “cleared”, this means that the user writes a logic ‘0’ to it.

10.1 Current Measurement Register

Table 10.2 Current Measurement Register

ADDR	R/W	REGISTER	B7	B6	B5	B4	B3	B2	B1	B0	DEFAULT
00h	R	Current Measurement	1249.3	624.6	312.3	156.2	78.1	39.0	19.5	9.76	00h

The Current Measurement register stores the measured current value delivered to the portable device (IBUS). This value is updated continuously while the device is in the Active power state. The bit weights are in mA and the range is from 9.76 mA to 2.5 A.

This data will be cleared when the device enters the Sleep or Detect states. This data will also be cleared whenever the port power switch is turned off (including during emulation or any time that VBUS is discharged).

10.2 Total Accumulated Charge Registers

Table 10.3 Total Accumulated Charge Registers

ADDR	R/W	REGISTER	B7	B6	B5	B4	B3	B2	B1	B0	DEFAULT
01h	R	Total Accumulated Charge High Byte	90968	45484	22742	11371	5685	2843	1421	710.7	00h
02h	R	Total Accumulated Charge Middle High	355.4	177.7	88.84	44.42	22.21	11.105	5.552	2.776	00h
03h	R	Total Accumulated Charge Middle Low Byte	1.388	0.6940	0.3470	0.1735	0.08676	0.0434	0.02169	0.01084	00h
04h	R	Total Accumulated Charge Low Byte	0.005422	0.00271	-	-	-	-	-	-	00h

The Total Accumulated Charge registers store the total accumulated charge delivered from the VS source to a portable device. The bit weighting of the registers is given in mA-hrs. The register value is reset to 00_00h only when the RATION_RST bit is set or if the RATION_EN bit is cleared. This value will be retained when the device transitions out of the Active state and resumes accumulation if the device returns to the Active state and charge rationing is still enabled.

These registers are updated every one (1) second while the UCS1002 is in the Active power state. Every time the value is updated, it is compared against the target value in the Charge Rationing Threshold registers (see [Section 10.6](#)).

This data is retained in the Sleep state.

10.3 Status Registers

Table 10.4 Status Registers

ADDR	R/W	REGISTER	B7	B6	B5	B4	B3	B2	B1	B0	DEFAULT
0Fh	R	Other Status	-	-	ALERT_PIN	ADET_PIN	CHG_ACT	EM_ACT	EM_STEP[1:0]		00h
10h	See Text	Interrupt Status	ERR	DISCHARGE_ERR	RESET	MIN_KEEP_OUT	TSD	OVER_VOLT	BACK_VOLT	OVER_LIM	00h
11h	R / R-C	General Status	RATION	-	-	CC_MODE	TREG	LOW_CUR	REM	ATT	00h
12h	R	Profile Status 1	NO_HS	-	-	VS_LOW	CUST	DCP	CDP	PT	00h
13h	R	Profile Status 2	-	LG7	LG6	LG5	LG4	LG3	LG2	LG1	00h
14h	R	Pin Status	-	PWR_EN_PIN	M2_PIN	M1_PIN	EM_EN_PIN	SEL_PIN	PWR_STATE [1:0]		00h

The Status registers store bits that indicate error conditions as well as Attach Detection and Removal Detection. Unless otherwise noted, these bits will operate as described when the UCS1002 is operating in Stand-alone mode.

10.3.1 Other Status - 0Fh

Bit 5 - ALERT_PIN - Reflects the status of the ALERT# pin. When set, indicates that the ALERT# pin is asserted low. This bit is set and cleared as the ALERT# pin changes states.

Bit 4 - ADET_PIN - Reflects the status of the A_DET# pin. When set, indicates that the A_DET# pin is asserted low. This bit is set and cleared as the A_DET# pin changes states.

APPLICATION NOTE: If S0 is '1', PWR_EN is enabled, and VS is not present, the ADET_PIN bit will cycle if the current draw exceeds the current capacity of the bypass switch.

Bit 3 - CHG_ACT - This bit is automatically set when $IBUS > I_{BUS_CHG}$ and cleared when $IBUS < I_{BUS_CHG}$

APPLICATION NOTE: The CHG_ACT bit does not indicate that a portable device has accepted one of the charger emulation profiles. This bit will cycle during the Dedicated Charger Emulation Cycle.

Bit 2 - EM_ACT - Indicates that the UCS1002 is in the Active state and emulating. The actual profile that is being applied is identified by PRE_EM_SEL[3:0] (see [Section 10.12.1, "Applied Charger Emulation - 30h"](#)). This bit is set and cleared automatically.

APPLICATION NOTE: The EM_ACT bit does not indicate that a portable device has accepted one of the emulation profiles. This bit will cycle during the Dedicated Charger Emulation Cycle.

Bits 1 - 0 - EM_STEP[1:0] - Indicates which stimulus / response pair is currently being applied by the charger emulation profile as shown in [Table 10.5](#). These bits are set and cleared automatically. Note

that the Legacy charger emulation profiles and the BC1.2 DCP charger emulation profile do not use Stimulus / Response Pair #3.

Table 10.5 EM_STEP Bit Decode

EM_STEP[1:0]		STIMULUS / RESPONSE #
1	0	
0	0	None applied / Waiting for Current
0	1	#1
1	0	#2
1	1	#3 if applicable

10.3.2 Interrupt Status - 10h

Bit 7 - ERR - Indicates that an error was detected and the device has entered the Error state. Writing this bit to a '0' will clear the Error state and allows the device to be returned to the Active state. When written to '0' all error conditions are checked. If all error conditions have been removed, the UCS1002 returns to the Active state. This bit is set automatically by the UCS1002 when the Error state is entered. Regardless of the fault handling mechanism used, if any other bit is set in the Interrupt Status register (10h), the device will not leave the Error state.

This bit is cleared automatically by the UCS1002 if the Auto-recovery fault handling functionality is active and no error conditions are detected. Likewise, this bit is cleared when the PWR_EN control is disabled.

- '0' (default) - There are no errors detected.
- '1' - One or more errors have been detected, and the UCS1002 has entered the Error state.

APPLICATION NOTE: If the Auto-recovery fault handling is not used, the ERR bit must be written to a logic '0' to be cleared. It will also be cleared when the PWR_EN control is disabled.

APPLICATION NOTE: Note that the ERR bit does not necessarily reflect the ALERT# pin status. The ALERT# pin may be cleared or asserted without the ERR bit changing states.

Bit 6 - DISCHARGE_ERR - Indicates that the UCS1002 was unable to discharge the VBUS node. This bit will be cleared when read if the error condition has been removed or if the ERR bit is cleared. This bit will cause the ALERT# pin to be asserted and the device to enter the Error state.

Bit 5 - RESET - Indicates that the UCS1002 has just been reset and should be re-programmed. This bit will be set at power up. This bit is cleared when read or when the PWR_EN control is toggled. The ALERT# pin is not asserted when this bit is set. This data is retained in the Sleep state.

Bit 4 - MIN_KEEP_OUT - Indicates that the V-I output on the VBUS pins has dropped below V_{BUS_MIN} . This bit will be cleared when read if the error condition has been removed or if the ERR bit is cleared. This bit will cause the ALERT# pin to be asserted and the device to enter the Error state.

Bit 3 - TSD - Indicates that the internal temperature has exceeded T_{TSD} threshold and the device has entered the Error state. This bit will be cleared when read if the error condition has been removed or if the ERR bit is cleared. This bit will cause the ALERT# pin to be asserted and the device to enter the Error state.

Bit 2 - OVER_VOLT - Indicates that the VS voltage has exceeded the V_{S_OV} threshold and the device has entered the Error state. This bit will be cleared when read if the error condition has been removed or if the ERR bit is cleared. This bit will cause the ALERT# pin to be asserted and the device to enter the Error state.

Bit 1 - BACK_VOLT - Indicates that the VBUS voltage has exceeded the VS or VDD voltages by more than 150 mV. This bit will be cleared when read if the error condition has been removed or if the ERR bit is cleared. This bit will cause the ALERT# pin to be asserted and the device to enter the Error state.

Bit 0 - OVER_ILIM - Indicates that the IBUS current has exceeded both the ILIM threshold and the I_{BUS_R2MIN} threshold settings. This bit will be cleared when read if the error condition has been removed or if the ERR bit is cleared. This bit will cause the ALERT# pin to be asserted and the device to enter the Error state.

10.3.3 General Status - 11h

Bit 7 - RATION - Indicates that the UCS1002 has delivered the programmed amount of power to a portable device. If the RATION_BEH bits are set to interrupt the host, this bit will cause the ALERT# pin to be asserted. This bit is cleared when read. This bit is also cleared automatically when the RATION_RST bit is set or the RATION_EN bit is cleared (see [Section 10.4.1, "General Configuration - 15h"](#)).

Bit 4 - CC_MODE - Indicates that the IBUS current has exceeded ILIM.

Bit 3 - TREG - Indicates that the internal temperature has exceeded T_{REG} and that the current limit has been reduced. This bit is cleared when read and will not cause the ALERT# pin to be asserted unless the ALERT_LINK bit is set.

Bit 2 - LOW_CUR - Indicates that a portable device has reduced its charge current to below ~6.4 mA and may be finished charging. This bit is cleared when read and will not cause the ALERT# pin to be asserted unless the ALERT_LINK bit is set.

Bit 1 - REM - Indicates that a Removal Detection event has occurred and there is no longer a portable device present. This bit is cleared when read and will not cause the ALERT# pin to be asserted. It will cause the A_DET# pin to be released.

Bit 0 - ATT - Indicates that an Attach Detection event has occurred and there is a new portable device present. This bit is cleared when read and will not cause the ALERT# pin to be asserted. It will cause the A_DET# pin to be asserted.

10.3.4 Profile Status 1 - 12h

These bits are indicators only and will not cause the ALERT# pin or A_DET# pin to change states. The CUST, DCP, CDP, and PT bits are cleared under the following circumstances: the PWR_EN control is disabled, a new Active mode is selected, or a Removal Detection event occurs.

Bit 7 - NO_HS - The NO_HS bit is only set during the Dedicated Charger Emulation Cycle (see [Section 9.10, "No Handshake"](#)). This bit is automatically cleared whenever a new charger emulation profile is applied.

APPLICATION NOTE: The NO_HS bit does not indicate that a portable device is drawing current and it may be cleared to '0' (indicating a handshake) and a portable device not charge. This bit is set at the end of each charger emulation profile if a portable device does not handshake with it. This bit will not be set at the same time that any other Profile Status register bits are set.

Bit 4 - VS_LOW - Indicates that the VS voltage is below the V_{S_UVLO} threshold and the port power switch is held off. This bit is cleared automatically when the VS voltage is above the V_{S_UVLO} threshold.

Bit 3 - CUST - Indicates that the portable device successfully performed a handshake with the user-defined Custom charger emulation profile during the DCE Cycle and is charging. Based on the Custom charger emulation profile configuration, the high-speed switch will be either open or closed (see [Section 10.13, "Custom Emulation Configuration Registers"](#)). The port power switch current limiting mode is determined by the Custom current limiting behavior settings (see [Section 10.14.2, "Custom Current Limiting Behavior Configuration - 51h"](#)).

Bit 2 - DCP - Indicates that the portable device accepted the BC1.2 DCP charger emulation profile and is charging. The high-speed switch will be controlled via the HSW_DCE bit (see [Section 10.4.5, "High-speed Switch Configuration - 25h"](#)), and the port power switch will use constant current limiting.

Bit 1 - CDP - Indicates that the portable device successfully performed a handshake with the BC1.2 CDP charger emulation profile and is charging. The high-speed switch will be closed, and the port power switch will use trip current limiting.

Bit 0 - PT - Indicates that the UCS1002 is in the Data Pass-through or BC1.2 SDP Active mode. The high-speed switch will be closed, and the port power switch will use trip current limiting.

APPLICATION NOTE: When the UCS1002 is configured as a Data Pass-through and a Removal event and then an Attach event occur without changing the Active mode, the PT bit will not be set again even though the UCS1002 is still operating as a Data Pass-through as configured. Toggling the M1 control will re-enable the PT status bit.

10.3.5 Profile Status 2 - 13h

These bits indicate which profile was accepted. These bits are indicators only and will not cause the ALERT# pin or A_DET# pin to change states. These bits are cleared under the following circumstances: the PWR_EN control is disabled, a new Active mode is selected, or a Removal Detection event occurs.

Bit 6 - LG7 - Indicates that the portable device successfully performed a handshake with the Legacy 7 charger emulation profile and is charging. The high-speed switch will be controlled via the HSW_DCE bit (see [Section 10.4.5, "High-speed Switch Configuration - 25h"](#)). The port power switch current limiting mode is determined by the Custom current limiting behavior settings (see [Section 10.14.2, "Custom Current Limiting Behavior Configuration - 51h"](#)).

Bit 5 - LG6 - Indicates that the portable device successfully performed a handshake with the Legacy 6 charger emulation profile and is charging. The high-speed switch will be controlled via the HSW_DCE bit (see [Section 10.4.5, "High-speed Switch Configuration - 25h"](#)). The port power switch current limiting mode is determined by the Custom current limiting behavior settings (see [Section 10.14.2, "Custom Current Limiting Behavior Configuration - 51h"](#)).

Bit 4 - LG5 - Indicates that the portable device successfully performed a handshake with the Legacy 5 charger emulation profile and is charging. The high-speed switch will be controlled via the HSW_DCE bit (see [Section 10.4.5, "High-speed Switch Configuration - 25h"](#)). The port power switch current limiting mode is determined by the Custom current limiting behavior settings (see [Section 10.14.2, "Custom Current Limiting Behavior Configuration - 51h"](#)).

Bit 3 - LG4 - Indicates that the portable device successfully performed a handshake with the Legacy 4 charger emulation profile and is charging. The high-speed switch will be controlled via the HSW_DCE bit (see [Section 10.4.5, "High-speed Switch Configuration - 25h"](#)). The port power switch current limiting mode is determined by the Custom current limiting behavior settings (see [Section 10.14.2, "Custom Current Limiting Behavior Configuration - 51h"](#)).

Bit 2 - LG3 - Indicates that the portable device successfully performed a handshake with the Legacy 3 charger emulation profile and is charging. The high-speed switch will be controlled via the HSW_DCE bit (see [Section 10.4.5, "High-speed Switch Configuration - 25h"](#)). The port power switch current limiting mode is determined by the Custom current limiting behavior settings (see [Section 10.14.2, "Custom Current Limiting Behavior Configuration - 51h"](#)).

Bit 1 - LG2 - Indicates that the portable device successfully performed a handshake with the Legacy 2 charger emulation profile and is charging. The high-speed switch will be controlled via the HSW_DCE bit (see Section 10.4.5, "High-speed Switch Configuration - 25h"). The port power switch current limiting mode is determined by the Custom current limiting behavior settings (see Section 10.14.2, "Custom Current Limiting Behavior Configuration - 51h").

Bit 0 - LG1 - Indicates that the portable device successfully performed a handshake with the Legacy 1 charger emulation profile and is charging. The high-speed switch will be controlled via the HSW_DCE bit (see Section 10.4.5, "High-speed Switch Configuration - 25h"). The port power switch current limiting mode is determined by the Custom current limiting behavior settings (see Section 10.14.2, "Custom Current Limiting Behavior Configuration - 51h").

10.3.6 Pin Status Register - 14h

The Pin Status register reflects the current pin state of the external control pins as well as identifying the power state. These bits are linked to the X_SET bits (see Section 10.4.3).

Bit 6 - PWR_EN_PIN - Reflects the PWR_EN control state. This bit is set and cleared automatically as the PWR_EN pin / PWR_EN_SET bit state changes.

Bit 5 - M2_PIN - Reflects the M2 pin state. This bit is set and cleared automatically as the M2 pin / M2_SET state changes.

Bit 4 - M1_PIN - Reflects the M1 pin state. This bit is set and cleared automatically as the M1 pin / M1_SET state changes.

Bit 3 - EM_EN_PIN - Reflects the EM_EN pin state. This bit is set and cleared automatically as the EM_EN pin / EM_EN_SET state changes.

Bit 2 - SEL_PIN - Reflects the polarity settings determined by the SEL pin decode. This bit is set or cleared automatically upon device power-up as the SEL pin is decoded.

- '0' - The PWR_EN control is active low.
- '1' - The PWR_EN control is active high.

Bits 1 - 0 - PWR_STATE[1:0] - Indicates the current power state as shown in Table 10.6. These bits are set and cleared automatically as the power state changes.

APPLICATION NOTE: Accessing the SMBus / I²C causes the UCS1002 to leave the Sleep state. As a result, the PWR_STATE[1:0] bits will never read as 00b.

Table 10.6 PWR_STATE Bit Decode

PWR_STATE[1:0]		POWER STATE
1	0	
0	0	Sleep
0	1	Detect
1	0	Active
1	1	Error

10.4 Configuration Registers

Table 10.7 Configuration Registers

ADDR	R/W	REGISTER	B7	B6	B5	B4	B3	B2	B1	B0	DEFAULT
15h	R/W	General Configuration	ALERT_MASK	-	ALERT_LINK	DISCHARGE	RATION_EN	RATION_RST	RATION_BEH [1:0]		01h
16h	R/W	Emulation Configuration	DIS_TO	-	-	EM_TIMEOUT_DIS	EM_RETRY	LEAVE_EMU_RESP	EM_RESET_TIME[1:0]		8Ch
17h	R/W	Switch Configuration	PIN_IGNORE	-	EM_EN_SET	M2_SET	M1_SET	S0_SET	PWR_EN_SET	LATCH_SET	04h
18h	R/W	Attach Detect Configuration	0	1	0	0	DISCHG_TIME_SEL[1:0]		ATT_TH[1:0]		46h
25h	R/W	High-speed Switch Configuration	-	-	-	1	HSW_CUST	HSW_CDP	HSW_DET	HSW_DCE	14h

The Configuration registers control basic device functionality.

10.4.1 General Configuration - 15h

The contents of this register are retained in Sleep.

Bit 7 - ALERT_MASK - Disables the ALERT# pin from asserting in the case of an error.

- '0' (default) - The ALERT# pin will be asserted if an error condition or indicator event is detected.
- '1' - The ALERT# pin will not be asserted in the event of an error condition.

Bit 5 - ALERT_LINK - Links the ALERT# pin to be asserted when the LOW_CUR and/or TREG bits are set.

- '0' (default) - The ALERT# pin will not be asserted if the LOW_CUR or TREG indicator bit is set.
- '1' - The ALERT# pin will be asserted if the LOW_CUR or TREG indicator bit is set.

Bit 4 - DISCHARGE - Forces the VBUS to be reset and discharged when the UCS1002 is in the Active state. Writing this bit to a logic '1' will cause the port power switch to be opened and the discharge circuitry to activate to discharge VBUS. The port power switch will remain open while this bit is '1'. This bit is not self-clearing.

Bit 3 - RATION_EN - Enables charge rationing functionality and power monitoring.

- '0' (default) - Charge rationing is disabled. The Total Accumulated Charge registers will be cleared to 00_00h and current data will no longer be accumulated. If the Total Accumulated Charge registers have already reached the Charge Rationing Threshold (see [Section 10.6, "Charge Rationing Threshold Registers"](#)), the applied response will be removed as if the charge rationing had been reset. This will also clear the RATION status bit (if set).
- '1' - Charge rationing is enabled (see [Section 7.5, "Battery Full"](#)).

Bit 2 - RATION_RST - Resets the charge rationing functionality. When this bit is set to '1', the Total Accumulated Charge registers are reset to 00_00h. In addition, when this bit is set, the RATION status bit will be cleared and, if there are no other errors or active indicators, the ALERT# pin will be released.

Bits 1 - 0 - RATION_BEH[1:0] - Controls the behavior when the power rationing threshold is reached as shown in [Table 7.1](#).

10.4.2 Emulation Configuration - 16h

The contents of this register are retained in Sleep.

Bit 7 - DIS_TO - Disables the timeout and idle reset functionality (see [Section 4.2.1.6, "SMBus Timeout and Idle Reset"](#)).

- '0' - The timeout and idle reset functionality is enabled.
- '1' (default) - The timeout and idle reset functionality is disabled. This is used for I²C compliance.

Bit 4 - EM_TIMEOUT_DIS - Disables the emulation circuitry timeout for all charger emulation profiles in the DCE Cycle. There is a separate bit to enable / disable the emulation timeout for the Custom charger emulation profile ([Section 10.13.1, "Custom Emulation Configuration - 40h"](#)); however, if the EM_TIMEOUT_DIS bit is set, the emulation timeout will also be disabled for the Custom charger emulation profile.

APPLICATION NOTE: If the EM_TIMEOUT_DIS bit is set and the Legacy 1, Legacy 3, or Custom charger emulation profiles were accepted during the DCE cycle, a removal is not detected. To avoid this issue, re-enable the emulation timeout after applying any test profiles and charging with the 'final' profile.

- '0' (default) - Emulation timeout is enabled during the Dedicated Charger Emulation Cycle. An individual charger emulation profile will be applied and maintained for the duration of the $t_{EM_TIMEOUT}$ value. When this timer expires, the UCS1002 will determine whether the charger emulation profile was successful and take appropriate action.
- '1' - Emulation timeout is disabled during the DCE Cycle. The applied charger emulation profile will not exit as a result of an emulation timeout event. The I_{BUS} current will be checked continuously and if it exceeds the I_{BUS_CHG} threshold for any reason, the charger emulation profile will be accepted.

Bit 3 - EM_RETRY - Configures whether the DCE Cycle will reset and restart if it reaches the final profile without the portable device drawing charging current and accepting one of the profiles. This bit is only used if the UCS1002 is configured to emulate a dedicated charger.

- '0' - Once the DCE Cycle is completed, it will not restart. The DPOUT and DMOUT will be left as High-Z pins and the port power switch will be closed. The current limiting mode is determined by the Custom current limiting behavior settings (see [Section 10.14.2, "Custom Current Limiting Behavior Configuration - 51h"](#)).
- '1' (default) - Once the DCE Cycle is completed, it will perform emulation reset and restart from the first enabled charger emulation profile in the DCE Cycle.

Bit 2 - LEAVE_EMU_RESP - Enables the Dedicated Charger Emulation Cycle mode to hold the DPOUT and DMOUT stimulus response after the UCS1002 has finished emulation using the Legacy, BC1.2 DCP, or Custom charger emulation profiles.

APPLICATION NOTE: If the HSW_DCE bit is set, the high-speed switch will be closed regardless of the status of the LEAVE_EMU_RESP bit. Leaving the emulation response applied will not allow normal USB traffic. Therefore, prior to setting the HSW_DCE bit, this bit should be cleared.

- '0' - The dedicated emulation circuitry will behave normally. It will remove the short condition when the $t_{EM_TIMEOUT}$ timer has expired regardless if the portable device has drawn charging current or not.
- '1' (default) - If a portable device begins drawing charging current while the UCS1002 is applying the BC1.2 DCP, Custom, or any of the Legacy charger emulation profiles during the DCE Cycle, the last response applied will be kept in place until a Removal Detection event occurs, the internal

temperature exceeds the T_{REG} value, or emulation is restarted. In the case of the BC1.2 DCP or Legacy 2 charger emulation profiles, this will be the short (R_{DCP_RES}). In the case of the Legacy 1, or Legacy 3 - 7 profiles, this will be the DPOUT and DMOUT pin voltages. If a portable device does not draw charging current, the DCE Cycle will behave normally.

Bits 1 - 0 - EM_RESET_TIME[1:0] - Determines the length of the t_{EM_RESET} time (see [Section 9.8.1, "Emulation Reset"](#)) as shown in [Table 10.8](#).

Table 10.8 EM_RESET_TIME Bit Decode

EM_RESET_TIME[1:0]		T_{EM_RESET} TIME (SEE Note 10.1)
1	0	
0	0	50 ms (default)
0	1	75 ms
1	0	125 ms
1	1	175 ms

Note 10.1 When measured, the actual emulation reset time will be t_{EM_RESET} plus $t_{DISCHARGE}$.

10.4.3 Switch Configuration - 17h

The contents of this register are retained in Sleep.

Bit 7 - PIN_IGNORE - Ignores the M1, M2, PWR_EN, and EM_EN pin states when determining the Active mode selection and power state.

- '0' (default) - The Active mode selection and power state will be set by the OR'd combination of the M1, M2, PWR_EN, and EM_EN pin states and the corresponding bit states.
- '1' - The Active mode selection and power state will be set by the individual control bits and not by the M1, M2, PWR_EN, and EM_EN pin states. These pin states are ignored.

Bit 5 - EM_EN_SET - In conjunction with other controls, determines the Active mode that is selected (see [Section 9.2, "Active Mode Selection"](#)) and power state (see [Table 5.1, "Power States Control Settings"](#)). This bit is OR'd with the EM_EN pin.

Bit 4 - M2_SET - In conjunction with other controls, determines the Active mode that is selected (see [Section 9.2](#)) and power state (see [Table 5.1](#)). This bit is OR'd with the M2 pin.

Bit 3 - M1_SET - In conjunction with other controls, determines the Active mode that is selected (see [Section 9.2](#)) and power state (see [Table 5.1](#)). This bit is OR'd with the M1 pin.

Bit 2 - S0_SET - In SMBus mode, enables the Attach and Removal Detection feature and affects the power state (see [Section 5.3.6, "S0 Input"](#)).

- '0' - Detection is not enabled. Also see [Table 5.1, "Power States Control Settings"](#).
- '1' (default) - Detection is enabled. Also see [Table 5.1](#).

Bit 1 - PWR_EN_SET - Controls whether the port power switch may be turned on or not and affects the power state (see [Section 5.3.4, "PWR_EN Input"](#)). This bit is OR'd with the PWR_EN pin and the polarity of both are controlled by SEL pin decode. Thus, if the polarity is set to active high, either the PWR_EN pin or this bit must be '1' to enable the port power switch.

Bit 0 - LATCH_SET - In SMBus mode, controls the fault handling routine that is used in the case that an error is detected (see [Section 5.3.5, "Latch Input"](#)).

- '0' (default) - The UCS1002 will automatically retry when an error condition is detected.
- '1' - The UCS1002 will latch its error conditions. In order for the device to return to normal Active state, the ERR bit must be cleared by the user.

10.4.4 Attach Detection Configuration - 18h

The contents of this register are retained in Sleep.

Bit 7 - RESERVED - Do not change. This bit will read '0' and should not be written to a logic '1'.

Bit 6 - RESERVED - Do not change. This bit will read '1' and should not be written to a logic '0'.

Bit 5 - RESERVED - Do not change. This bit will read '0' and should not be written to a logic '1'.

Bit 4 - RESERVED - Do not change. This bit will read '0' and should not be written to a logic '1'.

Bits 3 - 2 - DISCHG_TIME_SEL[1:0] - Sets the $t_{DISCHARGE}$ time as shown in [Table 10.9](#).

Table 10.9 Discharge Time Options

DISCHG_TIME_SEL[1:0]		$T_{DISCHARGE}$
1	0	
0	0	100 ms
0	1	200 ms (default)
1	0	300 ms
1	1	400 ms

Bits 1 - 0 - ATT_TH[1:0] - Determines the Attach Detection threshold (I_{DET_QUAL}) and Removal Detection thresholds ($I_{REM_QUAL_DET}$ and $I_{REM_QUAL_ACT}$) as shown in [Table 10.10](#).

APPLICATION NOTE: The removal threshold is different when operating in the Active power state versus when operating in the Detect power state.

Table 10.10 Attach / Removal Detection Threshold Options

ATT_TH[1:0]		ATTACH THRESHOLD / REMOVAL THRESHOLD (DETECT STATE)	REMOVAL THRESHOLD (ACTIVE STATE)
1	0		
0	0	200 μ A	100 μ A
0	1	400 μ A	300 μ A
1	0	800 μ A (default)	700 μ A (default)
1	1	1000 μ A	900 μ A

10.4.5 High-speed Switch Configuration - 25h

The contents of this register are retained in Sleep.

Bit 4 - RESERVED - This bit will default to '1'. Changing this bit will have no effect.

Bit 3 - HSW_CUST - Enables the USB high-speed data switch to be active during the Custom handshake. This control is checked at the beginning of charger emulation. Therefore, changing this control during emulation will have no immediate effect. Upon restarting charger emulation (as a result of the EM_RETRY bit being set, a Removal Detection event, or change of emulation controls), the high-speed switch will close.

- '0' (default) - The USB high-speed data switch is disabled while the Custom charger emulation profile is applied.
- '1' - The USB high-speed data switch is enabled while the Custom charger emulation profile is applied. Also, if the Custom charger emulation profile is accepted during the Dedicated Charger Emulation Cycle, the high-speed switch will stay closed.

Bit 2 - HSW_CDP - Enables the USB high-speed data switch to be active during the CDP handshake. This control is checked at the beginning of charger emulation. Therefore, changing this control during emulation will have no immediate effect. Upon restarting charger emulation (as a result of a Removal Detection event or change of emulation controls), the high-speed switch will close.

- '0' - The USB high-speed data switch is disabled during the CDP handshake.
- '1' (default) - The USB high-speed data switch is enabled during the CDP handshake.

Bit 1 - HSW_DET - Enables the USB high-speed data switch to be active during the Detect power state. If the S0 control is set to '0', this bit is ignored.

- '0' (default) - The USB high-speed data switch is open during the Detect power state.
- '1' - The USB high-speed data switch will be closed during the Detect power state.

Bit 0 - HSW_DCE - Enables the USB high-speed data switch after the DCP charger emulation profile or one of the Legacy charger emulation profiles was accepted during the DCE Cycle and the portable device is charging. This bit is ignored if the UCS1002 is not in the Active state. This bit will not cause the high-speed switch to be closed during emulation when the DCP and Legacy profiles are applied, only after the DCP or a Legacy charger emulation profile has been accepted.

- '0' (default) - The USB high-speed data switch will be open.
- '1' - The USB high-speed data switch will be closed.

10.5 Current Limit Register

Table 10.11 Current Limit Register

ADDR	R/W	REGISTER	B7	B6	B5	B4	B3	B2	B1	B0	DEFAULT
19h	R/W	Current Limit	-	-	-	-	-	ILIM_SW[2:0]			Set by COMM_SEL / ILIM

The Current Limit register controls the ILIM used by the port power switch. The default setting is based on the resistor on the COMM_SEL / ILIM pin and this value cannot be changed to be higher than hardware set value.

The contents of this register are retained in Sleep.

Bits 2 - 0 - ILIM_SW[2:0] - Sets the ILIM value as shown in [Table 10.12](#).

Table 10.12 ILIM_SW Bit Decode

ILIM_SW[2:0]			ILIM
2	1	0	
0	0	0	500 mA
0	0	1	900 mA
0	1	0	1.0 A
0	1	1	1.2 A
1	0	0	1.5 A
1	0	1	1.8 A
1	1	0	2.0 A
1	1	1	2.5 A

10.6 Charge Rationing Threshold Registers

Table 10.13 Charge Rationing Threshold Registers

ADDR	R/W	REGISTER	B7	B6	B5	B4	B3	B2	B1	B0	DEFAULT
1Ah	R/W	Charge Rationing Threshold High Byte	90968	45484	22742	11371	5685	2843	1421	710.7	FFh
1Bh	R/W	Charge Rationing Threshold Low Byte	355.4	177.7	88.84	44.42	22.21	11.105	5.552	2.776	FFh

The Charge Rationing Threshold registers set the maximum allowed charge that will be delivered to a portable device. Every time the Total Accumulated Charge registers are updated, the value is checked against this limit. If the value meets or exceeds this limit, the RATION bit is set (see [Section 10.4.1](#)) and action taken according to the RATION_BEH[1:0] bits (see [Section 10.4.1](#)).

The units are in mA-hrs with a range from 0 to ~181768.

The contents of this register are retained in Sleep.

10.7 Auto-recovery Configuration Register

Table 10.14 Auto-recovery Configuration Register

ADDR	R/W	REGISTER	B7	B6	B5	B4	B3	B2	B1	B0	DEFAULT
1Ch	R/W	Auto-recovery Configuration	-	TCYCLE[2:0]			TRST_SW[1:0]		VTST_SW[1:0]		2Ah

The contents of this register are retained in Sleep.

The Auto-recovery Configuration register sets the parameters used when the Auto-recovery fault handling algorithm is invoked (see [Section 7.6.1, "Auto-recovery Fault Handling"](#)).

Once the Auto-recovery fault handling algorithm has checked the over-temperature and back-drive conditions, it will set the ILIM value to I_{TEST} and then turn on the port power switch and start the t_{RST} Timer. If, after the timer has expired, the VBUS voltage is less than V_{TEST} , then it is assumed that a short circuit condition is present and the Error state is reset.

Bits 6 - 4 - TCYCLE[2:0] - Defines the delay (t_{CYCLE}) after the Error state is entered before the Auto-recovery fault handling algorithm is started as shown in [Table 10.15](#).

Table 10.15 t_{CYCLE} Options

TCYCLE [2:0]			TCYCLE TIME
2	1	0	
0	0	0	15 ms
0	0	1	20 ms
0	1	0	25 ms (default)
0	1	1	30 ms
1	0	0	35 ms
1	0	1	40 ms
1	1	0	45 ms
1	1	1	50 ms

Bits 3 - 2 - TRST_SW[1:0] - Sets the t_{RST} time as shown in [Table 10.16](#).

Table 10.16 TRST_SW Options

TRST_SW[1:0]		T_{RST}
1	0	
0	0	10 ms

Table 10.16 TRST_SW Options (continued)

TRST_SW[1:0]		T _{RST}
1	0	
0	1	15 ms
1	0	20 ms (default)
1	1	25 ms

Bits 1 - 0 - VTST_SW[1:0] - Sets the V_{TEST} value as shown in [Table 10.17](#).

Table 10.17 VTST_SW Options

VTST_SW[1:0]		V _{TEST}
1	0	
0	0	250 mV
0	1	500 mV
1	0	750 mV (default)
1	1	1000 mV

10.8 IBUS_CHG Configuration Register

Table 10.18 IBUS_CHG Configuration Register

ADDR	R/W	REGISTER	B7	B6	B5	B4	B3	B2	B1	B0	DEFAULT
1Eh	R/W	IBUS_CHG Configuration	-	-	-	-	78.1	39.0	19.5	9.76	04h

The IBUS_CHG Configuration register sets the I_{BUS_CHG} current value. If current greater than I_{BUS_CHG} is detected flowing out of VBUS, emulation is successful. The bit weights are in mA, and the range is from 9.76 mA to 156.16 mA.

APPLICATION NOTE: The contents of this register are not retained in Sleep.

10.9 tDET_CHARGE Configuration Register

Table 10.19 tDET_CHARGE Configuration Register

ADDR	R/W	REGISTER	B7	B6	B5	B4	B3	B2	B1	B0	DEFAULT
1Fh	R/W	tDET_CHARGE Configuration	-	-	-	DC_TEMP_SET[1:0]		DET_CHARGE_SET [2:0]			03h

The contents of this register are retained in Sleep.

The TDET_CHARGE Configuration register controls the t_{DC_TEMP} and t_{DET_CHARGE} timing. The t_{DC_TEMP} timer is started whenever the temperature exceeds T_{REG} . This timer is meant to give the system time to cool at the lower ILIM setting before changing ILIM again. The t_{DET_CHARGE} timer is started whenever the VBUS voltage is discharged and the bypass switch is re-activated. This timer is meant to be a delay to allow the VBUS capacitor to charge before detecting an Attach Detection event.

Bits 4 - 3 - DC_TEMP_SET[2:0] - Determines the t_{DC_TEMP} time as shown in [Table 10.20](#).

Bits 2 - 0 - DET_CHARGE_SET[2:0] - Determines the t_{DET_CHARGE} time as shown in [Table 10.21](#).

APPLICATION NOTE: If t_{DET_CHARGE} time is increased greater than 800 ms, larger bus capacitors can be accommodated; however, with a portable device present and PWR_EN disabled, a Removal Detection event and then another Attach Detection event will occur.

Table 10.20 DC_TEMP_SET Bit Decode

DC_TEMP_SET[1:0]		TDC_TEMP
1	0	
0	0	200 ms (default)
0	1	400 ms
1	0	800 ms
1	1	1600 ms

Table 10.21 DET_CHARGE_SET Bit Decode

DET_CHARGE_SET[2:0]			TDET_CHARGE
2	1	0	
0	0	0	200 ms
0	0	1	400 ms
0	1	0	600 ms
0	1	1	800 ms (default)
1	0	0	1000 ms
1	0	1	1200 ms
1	1	0	1400 ms
1	1	1	2000 ms

10.10 Preloaded Emulation Enable Registers

Table 10.22 Preloaded Emulation Enable Registers

ADDR	R/W	REGISTER	B7	B6	B5	B4	B3	B2	B1	B0	DEFAULT
20h	R/W	BCS Emulation Enable	-	-	-	DCP_EM_DIS	-	1	1	0	06h
21h	R/W	Legacy Emulation Enable	-	LG7_EM_DIS	LG6_EM_DIS	LG5_EM_DIS	LG4_EM_DIS	LG3_EM_DIS	LG2_EM_DIS	LG1_EM_DIS	00h

The Preloaded Emulation Enable registers enable the charger emulation profiles used by the emulation circuitry.

10.10.1 BCS Emulation Enable - 20h

The contents of this register are retained in Sleep.

Bit 4 - DCP_EM_DIS - Disables the DCP charger emulation profile in the DCE Cycle. This bit is ignored if the M1, M2, and EM_EN control settings have selected DCP mode (see [Table 9.1, "Active Mode Selection"](#)).

- '0' (default) - The BC1.2 DCP charger emulation profile is enabled during the Dedicated Charger Emulation Cycle.
- '1' - The BC1.2 DCP charger emulation profile is not enabled during the DCE Cycle.

Bit 2 - RESERVED - Do not change. This bit will read '1' and should not be written to a logic '0'.

Bit 1 - RESERVED - Do not change. This bit will read '1' and should not be written to a logic '0'.

Bit 0 - RESERVED - Do not change. This bit will read '0' and should not be written to a logic '1'.

10.10.2 Legacy Emulation Enable - 21h

The contents of this register are retained in Sleep.

Bit 6 - LG7_EM_DIS - Disables the Legacy 7 charger emulation profile.

- '0' (default) - The Legacy 7 charger emulation profile is enabled.
- '1' - The Legacy 7 charger emulation profile is not enabled.

Bit 5 - LG6_EM_DIS - Disables the Legacy 6 charger emulation profile.

- '0' (default) - The Legacy 6 charger emulation profile is enabled.
- '1' - The Legacy 6 charger emulation profile is not enabled.

Bit 4 - LG5_EM_DIS - Disables the Legacy 5 charger emulation profile.

- '0' (default) - The Legacy 5 charger emulation profile is enabled.
- '1' - The Legacy 5 charger emulation profile is not enabled.

Bit 3 - LG4_EM_DIS - Disables the Legacy 4 charger emulation profile.

- '0' (default) - The Legacy 4 charger emulation profile is enabled.

- '1' - The Legacy 4 charger emulation profile is not enabled.
- Bit 2 - LG3_EM_DIS - Disables the Legacy 3 charger emulation profile.
- '0' (default) - The Legacy 3 charger emulation profile is enabled.
 - '1' - The Legacy 3 charger emulation profile is not enabled.
- Bit 1 - LG2_EM_DIS - Disables the Legacy 2 charger emulation profile.
- '0' (default) - The Legacy 2 charger emulation profile is enabled.
 - '1' - The Legacy 2 charger emulation profile is not enabled.
- Bit 0 - LG1_EM_DIS - Disables the Legacy 1 charger emulation profile.
- '0' (default) - The Legacy 1 charger emulation profile is enabled.
 - '1' - The Legacy 1 charger emulation profile is not enabled.

10.11 Preloaded Emulation Timeout Configuration Registers

Table 10.23 Preloaded Emulation Timeout Configuration Registers

ADDR	R/W	REGISTER	B7	B6	B5	B4	B3	B2	B1	B0	DEFAULT
22h	R/W	BCS Emulation Timeout Config	-	-	DCP_EM_TIMEOUT[1:0]		0	0	0	0	10h
23h	R/W	Legacy Emulation Timeout Config 1	LG1_EM_TIMEOUT[1:0]		LG2_EM_TIMEOUT[1:0]		LG3_EM_TIMEOUT[1:0]		LG4_EM_TIMEOUT[1:0]		B0h
24h	R/W	Legacy Emulation Timeout Config 2	-	-	LG5_EM_TIMEOUT[1:0]		LG6_EM_TIMEOUT[1:0]		LG7_EM_TIMEOUT[1:0]		04h

The Preloaded Emulation Timeout Configuration registers control the $t_{EM_TIMEOUT}$ setting that is applied whenever the indicated preloaded charger emulation profile is applied during the DCE Cycle. These settings are not used if the EM_TIMEOUT_DIS bit is set.

10.11.1 BCS Emulation Timeout Config - 22h

The contents of this register are retained in Sleep.

Bits 5 - 4 - DCP_EM_TIMEOUT[1:0] - Defines the $t_{EM_TIMEOUT}$ setting, as shown in [Table 10.24](#), that is applied when the BC1.2 DCP charger emulation profile is used during the DCE Cycle. Default is 1.6 s (01b).

Bit 3 - RESERVED - This bit will default to '0'. Changing this bit will have no effect.

Bit 2 - RESERVED - This bit will default to '0'. Changing this bit will have no effect.

Bit 1 - RESERVED - Do not change. This bit will read '0' and should not be written to a logic '1'.

Bit 0 - RESERVED - Do not change. This bit will read '0' and should not be written to a logic '1'.

Table 10.24 X_EM_TIMEOUT Bit Decode

X_EM_TIMEOUT[1:0]		T _{EM_TIMEOUT} APPLIED
1	0	
0	0	0.8 s
0	1	1.6 s
1	0	6.4 s
1	1	12.8 s

10.11.2 Legacy Emulation Timeout Config 1 - 23h

The contents of this register are retained in Sleep.

Bits 7 - 6 - LG1_EM_TIMEOUT[1:0] - Defines the $t_{EM_TIMEOUT}$ setting, as shown in [Table 10.24](#), that is applied when the Legacy 1 charger emulation profile is used during the DCE Cycle. Default is 6.4 s (10b).

Bits 5 - 4 - LG2_EM_TIMEOUT[1:0] - Defines the $t_{EM_TIMEOUT}$ setting, as shown in [Table 10.24](#), that is applied when the Legacy 2 charger emulation profile is used during the DCE Cycle. Default is 12.8 s (11b).

Bits 3 - 2 - LG3_EM_TIMEOUT[1:0] - Defines the $t_{EM_TIMEOUT}$ setting, as shown in [Table 10.24](#), that is applied when the Legacy 3 charger emulation profile is used during the DCE Cycle. Default is 0.8 s (00b).

Bits 1 - 0 - LG4_EM_TIMEOUT[1:0] - Defines the $t_{EM_TIMEOUT}$ setting, as shown in [Table 10.24](#), that is applied when the Legacy 4 charger emulation profile is used during the DCE Cycle. Default is 0.8 s (00b).

10.11.3 Legacy Emulation Timeout Config 2 - 24h

The contents of this register are retained in Sleep.

Bits 5 - 4 - LG5_EM_TIMEOUT[1:0] - Defines the $t_{EM_TIMEOUT}$ setting, as shown in [Table 10.24](#), that is applied when the Legacy 5 charger emulation profile is used during the DCE Cycle. Default is 0.8 s (00b).

Bits 3 - 2 - LG6_EM_TIMEOUT[1:0] - Defines the $t_{EM_TIMEOUT}$ setting, as shown in [Table 10.24](#), that is applied when the Legacy 6 charger emulation profile is used during the DCE Cycle. Default is 1.6 s (01b).

Bits 1 - 0 - LG7_EM_TIMEOUT[1:0] - Defines the $t_{EM_TIMEOUT}$ setting, as shown in [Table 10.24](#), that is applied when the Legacy 7 charger emulation profile is used during the DCE Cycle. Default is 0.8 s (00b).

10.12 Preloaded Emulation Configuration Registers

Table 10.25 Preloaded Emulation Configuration Registers

ADDR	R/W	REGISTER	B7	B6	B5	B4	B3	B2	B1	B0	DEFAULT
30h	R	Applied Charger Emulation	-	-	-	-	PRE_EM_SEL[3:0]				00h
31h	R	Preloaded Emulation Stimulus 1 - Config 1	-	S1_TD_TYPE	S1_TD[2:0]			STIM1[2:0]			00h
32h	R	Preloaded Emulation Stimulus 1 - Config 2	S1_R1MAG[3:0]				S1_R1[3:0]				00h
33h	R	Preloaded Emulation Stimulus 1 - Config 3	-	-	S1_PUPD[1:0]		S1_TH[3:0]				00h
34h	R	Preloaded Emulation Stimulus 1 - Config 4	-	-	-	-	-	S1_RATIO[2:0]			00h
35h	R	Preloaded Emulation Stimulus 2 - Config 1	-	S2_TD_TYPE	S2_TD[2:0]			STIM2[2:0]			00h
36h	R	Preloaded Emulation Stimulus 2 - Config 2	S2_R2MAG[3:0]				S2_R2[3:0]				00h
37h	R	Preloaded Emulation Stimulus 2 - Config 3	-	-	S2_PUPD[1:0]		S2_TH[3:0]				00h
38h	R	Preloaded Emulation Stimulus 2 - Config 4	-	-	-	-	-	S2_RATIO[2:0]			00h
39h	R	Preloaded Emulation Stimulus 3 - Config 1	-	S3_TD_TYPE	S3_TD[2:0]			STIM3[2:0]			00h
3Ah	R	Preloaded Emulation Stimulus 3 - Config 2	S3_R3MAG[3:0]				S3_R3[3:0]				00h

Table 10.25 Preloaded Emulation Configuration Registers (continued)

ADDR	R/W	REGISTER	B7	B6	B5	B4	B3	B2	B1	B0	DEFAULT
3Bh	R	Preloaded Emulation Stimulus 3 - Config 3	-	-	S3_PUPD[1:0]		S3_TH[3:0]			00h	

The Preloaded Emulation Configuration registers store the settings loaded from internal memory as required for the preloaded charger emulation profile that is actively being applied. These registers are read only.

10.12.1 Applied Charger Emulation - 30h

The contents of this register are not retained in Sleep. The contents are updated as the charger emulation profile being applied changes.

Bits 3 - 0 - PRE_EM_SEL[3:0] - Indicates which of the charger emulation profiles is being actively applied as shown in [Table 10.26](#).

Table 10.26 Applied Emulation Selection

PRE_EM_SEL[3:0] SETTING				APPLIED CHARGER EMULATION
3	2	1	0	
0	0	0	0	Data Pass-through or BC1.2 SDP
0	0	0	1	BC1.2 CDP
0	0	1	0	BC1.2 DCP
0	0	1	1	Legacy 1
0	1	0	0	Legacy 2
0	1	0	1	Legacy 3
0	1	1	0	Legacy 4
0	1	1	1	Legacy 5
1	0	0	0	Legacy 6
1	0	0	1	Legacy 7
1	0	1	0	Custom Profile
All others				Not used

10.12.2 Preloaded Emulation Configuration Registers 31h - 3Bh

These registers store the emulation configuration settings for the currently applied preloaded charger emulation profile. The contents of these registers are loaded dynamically during charger emulation. When the Custom charger emulation profile is being applied, the contents of these registers will remain set at the previously applied preloaded charger emulation profile.

APPLICATION NOTE: The Legacy charger emulation profiles and the BC1.2 DCP charger emulation profile do not use the Stimulus 3 Configuration registers (39h - 3Bh). Whenever these charger emulation profiles are applied, registers 39h - 3Bh will not be updated and their contents should be ignored.

10.12.3 Preloaded Emulation Stimulus X - Config 1 - 31h, 35h, 39h

The contents of this register are not retained during Sleep. They are updated as needed.

APPLICATION NOTE: The Legacy charger emulation profiles do not use these settings. Whenever a Legacy charger emulation profile is applied within the DCE Cycle, these controls will not be updated and should be ignored. These settings are only used by the BC1.2 CDP and BC1.2 DCP charger emulation profiles.

Bit 6 - SX_TD_TYPE - Determines the behavior of the stimulus timer.

- '0' - The stimulus timer is a delay from when the stimulus is detected until the response is performed.
- '1' - The stimulus timer controls how long the response is applied after the stimulus is detected. The response is applied immediately and held for the duration of the timer then removed (if the stimulus has been removed).

Bits 5 - 3 - SX_TD[2:0] - Determines the stimulus X $t_{\text{STIM_DEL}}$ value as shown in [Table 10.27](#).

Bits 2 - 0 - STIMX[2:0] - Determines the stimulus that is used as shown in [Table 10.28](#).

Table 10.27 Stimulus Delay Time Options

SX_TD[2:0] SETTING			TIME DELAY
2	1	0	
0	0	0	0 ms
0	0	1	1 ms
0	1	0	5 ms
0	1	1	10 ms
1	0	0	20 ms
1	0	1	40 ms
1	1	0	80 ms
1	1	1	100 ms

Table 10.28 Stimulus Options

STIMX[2:0] SETTING			STIMULUS
2	1	0	
0	0	0	VBUS voltage ready to be applied (before port power switch is closed) (default). Next stimulus will not wait for this stimulus to be removed.
0	0	1	DPOUT Voltage is > threshold (SX_TH).
0	1	0	Window comparator. DPOUT Voltage is < threshold (SX_TH) and DPOUT Voltage is > fixed threshold (see Note 10.2).
0	1	1	DMOUT Voltage is > threshold (SX_TH).
1	0	0	Do not use.
1	0	1	Do not use.
1	1	0	DPOUT Voltage is > threshold (SX_TH).
1	1	1	VBUS voltage is present (after port power switch is closed). Next stimulus will not wait for this stimulus to be removed.

Note 10.2 The lower threshold for the window comparator option is fixed at 400 mV and only applies to the DPOUT pin. This setting cannot be used for the DMOUT port.

10.12.4 BC1.2 Emulation Stimulus X - Config 2 - 32h, 36h, 3Ah

The contents of this register are retained in Sleep.

Bits 7 - 4 - SX_RMAG[3:0] - Determines the magnitude of the response to the stimulus. The bit decode changes meaning based on which response was selected as shown in [Table 10.30](#). [Table 10.31](#) through [Table 10.33](#) show the specific decode for each function.

APPLICATION NOTE: Data written to any field that is identified as “do not use” will not be accepted. The data will not be updated and the settings will remain set at the previous value.

Bits 3 - 0 - SX_RX[3:0] - Defines the stimulus response as shown in [Table 10.29](#).

Table 10.29 Stimulus Response

SX_RX[3:0] SETTING				STIMULUS RESPONSE
3	2	1	0	
0	0	0	0	Remove previous response on DPOUT and DMOUT.
0	0	0	1	Apply voltage on DPOUT (see Note 10.3).
0	0	1	0	Apply voltage on DMOUT (see Note 10.4).
0	0	1	1	Apply voltage on DPOUT and DMOUT.
0	1	0	0	Connect resistor from DPOUT to GND (see Note 10.3).
0	1	0	1	Do not use.
0	1	1	0	Connect voltage divider from VBUS to GND with “center” at DPOUT (see Note 10.3).
0	1	1	1	Connect resistor from DMOUT to GND (see Note 10.4).
1	0	0	0	Do not use.
1	0	0	1	Connect voltage divider from VBUS to GND with “center” at DMOUT (see Note 10.4).
1	0	1	0	Connect $\leq 200 \Omega$ resistor from DPOUT to DMOUT.
1	0	1	1	Do not use.
1	1	0	0	Connect voltage divider from VBUS to GND with “center” at DPOUT. Connect voltage divider from VBUS to GND with “center” at DMOUT.
1	1	0	1	Connect resistor from DPOUT to GND and from DMOUT to GND.
1	1	1	0	If STIMX[2:0] = 000b, the 15 k Ω pull-down resistors applied to DPOUT and DMOUT during emulation reset are not removed. If STIMX[2:0] = 111b, the 15 k Ω pull-down resistors applied to DPOUT and DMOUT during emulation reset are removed. For all other STIMX[2:0] settings, whatever was applied is not changed.
1	1	1	1	

Note 10.3 If STIMX[2:0] = 000b and no other response was applied to the DMOUT pin, the 15 k Ω pull-down resistor applied to the DMOUT pin during emulation reset is not removed. Otherwise, the previous response is left on the DMOUT pin (if applicable) or the 15 k Ω pull-down resistor is removed.

Note 10.4 If STIMX[2:0] = 000b and no other response was applied to the DPOUT pin, the 15 k Ω pull-down resistor applied to the DPOUT pin during emulation reset is not removed. Otherwise, the previous response is left on the DPOUT pin (if applicable) or the 15 k Ω pull-down resistor is removed.

Table 10.30 Response Magnitude Meaning

RESPONSE		X_SX_RMAG[3:0] BIT MEANINGS
0000b - 0011b	Apply voltage on DPOUT / DMOUT	Voltage to be applied relative to ground (see Table 10.33).
0100b, 0111b, 1101b - 1111b	Apply resistor on DPOUT / DMOUT to GND or VBUS	Magnitude of resistor (see Table 10.32).
0110b, 1001b, 1100b	Apply voltage divider from VBUS to GND with “center” at DPOUT / DMOUT	Minimum resistance of voltage divider from VBUS to GND (sum of $R_1 + R_2$) (see Table 10.31).
1010b	Apply resistor between DPOUT and DMOUT	Not used.

Table 10.31 Voltage Divider Minimum Impedance Options

SX_RXMAG[3:0] SETTING				VOLTAGE DIVIDER MINIMUM IMPEDANCE OPTIONS
3	2	1	0	
0	0	0	0	93 kΩ
0	0	0	1	100 kΩ
0	0	1	0	125 kΩ
0	0	1	1	150 kΩ
0	1	0	0	200 kΩ
0	1	0	1	200 kΩ
0	1	1	0	200 kΩ
0	1	1	1	200 kΩ
1	0	0	0	93 kΩ
1	0	0	1	100 kΩ
1	0	1	0	125 kΩ
1	0	1	1	150 kΩ
1	1	0	0	200 kΩ
1	1	0	1	200 kΩ
1	1	1	0	200 kΩ
1	1	1	1	Do not use

Table 10.32 Stimulus Response Resistor Options

SX_RXMAG[3:0] SETTING				RESISTOR ON VBUS TO DX_OUT OR FROM DX_OUT TO GND
3	2	1	0	
0	0	0	0	1.8 kΩ
0	0	0	1	10 kΩ
0	0	1	0	15 kΩ
0	0	1	1	20 kΩ
0	1	0	0	25 kΩ
0	1	0	1	30 kΩ
0	1	1	0	40 kΩ
0	1	1	1	43 kΩ
1	0	0	0	50 kΩ
1	0	0	1	60 kΩ
1	0	1	0	75 kΩ
1	0	1	1	80 kΩ
1	1	0	0	100 kΩ
1	1	0	1	120 kΩ
1	1	1	0	150 kΩ
1	1	1	1	Do not use

Table 10.33 Stimulus Response Voltage Options

SX_RXMAG[3:0] SETTING				VOLTAGE ON DPOUT / DMOUT
3	2	1	0	
0	0	0	0	Pull-down
0	0	0	1	400 mV
0	0	1	0	400 mV
0	0	1	1	400 mV
0	1	0	0	400 mV
0	1	0	1	500 mV
0	1	1	0	600 mV

Table 10.33 Stimulus Response Voltage Options (continued)

SX_RXMAG[3:0] SETTING				VOLTAGE ON DPOUT / DMOUT
3	2	1	0	
0	1	1	1	700 mV
1	0	0	0	800 mV
1	0	0	1	900 mV
1	0	1	0	1400 mV
1	0	1	1	1600 mV
1	1	0	0	1800 mV
1	1	0	1	2000 mV
1	1	1	0	2200 mV
1	1	1	1	Do not use

10.12.5 Emulation Stimulus X - Config 3 - 33h, 37h, 3Bh

The contents of this register are retained in Sleep.

APPLICATION NOTE: The Legacy charger emulation profiles do not use these settings. Whenever a Legacy charger emulation profile is applied within the DCE Cycle, these controls will not be updated and should be ignored. These settings are only used by the BC1.2 CDP and DCP charger emulation profiles.

Bits 5 - 4 - SX_PUPD[1:0] - Determines the magnitude of the pull-down current applied on the DPOUT and DMOUT pins when the stimulus response is to apply a voltage and the voltage magnitude is set at pull-down (0000b). The bit decode is given in [Table 10.34](#).

Bits 3 - 0 - SX_TH[3:0] - Defines the threshold value, as shown in [Table 10.35](#), for the specified stimulus. If the stimulus is VBUS voltage is ready to be applied or applied (i.e., STIMX[2:0] = 000b or 111b), the threshold value is ignored.

Table 10.34 Pull-Down Magnitude

SX_PUPD		PULL-DOWN CURRENT
1	0	
0	0	10 μ A
0	1	50 μ A
1	0	100 μ A
1	1	150 μ A

Table 10.35 Stimulus Threshold Values

SX_TH[3:0] SETTING				VOLTAGE ON DPOUT / DMOUT
3	2	1	0	
0	0	0	0	400 mV
0	0	0	1	400 mV
0	0	1	0	400 mV
0	0	1	1	300 mV
0	1	0	0	400 mV
0	1	0	1	500 mV
0	1	1	0	600 mV
0	1	1	1	700 mV
1	0	0	0	800 mV
1	0	0	1	900 mV
1	0	1	0	1400 mV
1	0	1	1	1600 mV
1	1	0	0	1800 mV
1	1	0	1	2000 mV
1	1	1	0	2200 mV
1	1	1	1	Do not use

10.12.6 Emulation Stimulus X - Config 4 - 34h, 38h

The contents of this register are retained in Sleep.

APPLICATION NOTE: The BC1.2 DCP and CDP charger emulation profiles do not use this control. Whenever the BC1.2 CDP or DCP charger emulation profile is applied, these controls will not be updated and should be ignored. These settings are only used by the Legacy charger emulation profiles.

Bits 2 - 0 - SX_RATIO[2:0] - Determines the voltage divider ratio, as shown in [Table 10.36](#), when the stimulus response is set to connect a voltage divider (i.e., SX_RX[3:0] = 0110b, 1001b, or 1100b).

Table 10.36 Voltage Divider Ratio Options

SX_RATIOX[2:0] SETTING			VOLTAGE DIVIDER RATIO
2	1	0	
0	0	0	0.25
0	0	1	0.33
0	1	0	0.4
0	1	1	0.5
1	0	0	0.54
1	0	1	0.6
1	1	0	0.66
1	1	1	Do not use

10.13 Custom Emulation Configuration Registers

Table 10.37 Custom Emulation Configuration Registers

ADDR	R/W	REGISTER	B7	B6	B5	B4	B3	B2	B1	B0	DEFAULT
40h	R/W	Custom Emulation Config	-	-	CS1_TIME_OUT_DIS	CS1_EM_TIMEOUT[1:0]		CS1_FIRST	0	CS1_EM_DIS	01h
41h	R/W	Custom Emulation Stimulus 1 - Config 1	-	CS1_S1_TD_TYPE	CS1_S1_TD[2:0]			CS1_STIM1[2:0]			00h
42h	R/W	Custom Emulation Stimulus 1 - Config 2	CS1_S1_R1MAG[3:0]				CS1_S1_R1[3:0]				00h
43h	R/W	Custom Emulation Stimulus 1 - Config 3	-	-	CS1_S1_PUPD[1:0]		CS1_S1_TH[3:0]				00h
44h	R/W	Custom Emulation Stimulus 1 - Config 4	-	-	-	-	-	CS1_S1_RATIO[2:0]			00h
45h	R/W	Custom Emulation Stimulus 2 - Config 1	-	CS1_S2_TD_TYPE	CS1_S2_TD[2:0]			CS1_STIM2[2:0]			00h

Table 10.37 Custom Emulation Configuration Registers (continued)

ADDR	R/W	REGISTER	B7	B6	B5	B4	B3	B2	B1	B0	DEFAULT
46h	R/W	Custom Emulation Stimulus 2 - Config 2	CS1_S2_R2MAG[3:0]			CS1_S2_R2[3:0]			00h		
47h	R/W	Custom Emulation Stimulus 2 - Config 3	-	-	CS1_S2_PUP D[1:0]		CS1_S2_TH[3:0]			00h	
48h	R/W	Custom Emulation Stimulus 2 - Config 4	-	-	-	-	-	CS1_S2_RATIO[2:0]		00h	
49h	R/W	Custom Emulation Stimulus 3 - Config 1	-	CS1_S3 TD TYPE	CS1_S3_TD[2:0]		CS1_STIM3[2:0]			00h	
4Ah	R/W	Custom Emulation Stimulus 3 - Config 2	CS1_S3_R3MAG[3:0]			CS1_S3_R3[3:0]			00h		
4Bh	R/W	Custom Emulation Stimulus 3 - Config 3	-	-	CS1_S3_PUP D[1:0]		CS1_S3_TH[3:0]			00h	
4Ch	R/W	Custom Emulation Stimulus 3 - Config 4	-	-	-	-	-	CS1_S3_RATIO[2:0]		00h	

The Custom Emulation Configuration registers store the values used by the Custom charger emulation circuitry. The Custom charger emulation profile is set up as three stimuli and the respective responses. See application note 24.14 "UCS1002 Fundamentals of Custom Charger Emulation".

10.13.1 Custom Emulation Configuration - 40h

The contents of this register are retained in Sleep.

Bit 5 - CS1_TIMEOUT_DIS - Disables the Emulation Timeout timer when the Custom charger emulation profile is applied during the DCE Cycle. If the EM_TIMEOUT_DIS is set, this bit will have no effect (see [Section 10.4.2, "Emulation Configuration - 16h"](#)).

APPLICATION NOTE: If the CS1_TIMEOUT_DIS bit is set and the Custom charger emulation profile was accepted during the DCE cycle, a removal is not detected. To avoid this issue, re-enable the emulation timeout after applying any test profiles and charging with the 'final' profile.

- '0' (default) - The Emulation Timeout timer is enabled when the Custom charger emulation profile is applied during the DCE Cycle and the EM_TIMEOUT_DIS bit is not set.
- '1' - The Emulation Timeout timer is disabled when the Custom charger emulation profile is applied during the DCE Cycle. When the Custom charger emulation profile is being applied, the UCS1002 will be constantly monitoring the I_{BUS} current. When the I_{BUS} current is greater than I_{BUS_CHG}

regardless of the reason, then the Custom charger emulation profile will be accepted. If the portable device does not draw more than I_{BUS_CHG} current, then the UCS1002 will continue waiting until this bit is cleared.

Bits 4 - 3 - CS1_EM_TIMEOUT[1:0] - Determines the $t_{EM_TIMEOUT}$ value, as shown in [Table 10.24](#), that is used when the Custom charger emulation profile is used during the DCE Cycle.

Bit 2 - CS1_FIRST - Determines whether the Custom charger emulation profile is placed first or last in the DCE Cycle.

- '0' (default) - The Custom charger emulation profile is the last of the profiles applied during the DCE Cycle.
- '1' - The Custom charger emulation profile is the first of the profiles applied during the DCE Cycle.

Bit 1 - RESERVED - Do not change. This bit will read '0' and should not be written to a logic '1'.

Bit 0 - CS1_EM_DIS - Disables the Custom charger emulation profile.

- '0' - The Custom charger emulation profile is enabled.
- '1' (default) - The Custom charger emulation profile is not enabled.

10.13.2 Custom Stimulus / Response Pair X - Config 1 - 41h, 45h, 49h

The contents of this register are retained in Sleep.

Bit 6 - CS1_SX_TD_TYPE - Determines the behavior of the stimulus timer.

- '0' - The stimulus timer is a delay from when the stimulus is detected until the response is performed.
- '1' - The stimulus timer controls how long the response is applied after the stimulus is detected. The response is applied immediately and held for the duration of the timer then removed (if the stimulus has been removed).

Bits 5 - 3 - CS1_SX_TD[2:0] - Determines the stimulus X t_{STIM_DEL} value as shown in [Table 10.27](#).

Bits 2 - 0 - CS1_STIMX[2:0] - Determines the stimulus that is used as shown in [Table 10.28](#).

10.13.3 Custom Stimulus / Response Pair X - Config 2 - 42h, 46h, 4Ah

The contents of this register are retained in Sleep.

Bits 7 - 4 - CS1_SX_RXMAG[3:0] - Determines the magnitude of the response to the stimulus. The bit decode changes meaning based on which response was selected as shown in [Table 10.30](#). [Table 10.31](#) through [Table 10.33](#) show the specific decode for each function.

Bits 3 - 0 - CS1_SX_RX[3:0] - Defines the stimulus response as shown in [Table 10.29](#).

10.13.4 Custom Stimulus / Response Pair X - Config 3 - 43h, 47h, 4Bh

The contents of this register are retained in Sleep.

Bits 5 - 4 - CS1_SX_PUPD[1:0] - Determines the magnitude of the pull-down current applied on the DPOUT and DMOUT pins when the stimulus response is to apply a voltage and the voltage magnitude is set at pull-down (0000b). The bit decode is given in [Table 10.34](#).

Bits 3 - 0 - CS1_SX_TH[3:0] - Defines the threshold value, as shown in [Table 10.35](#), for the specified stimulus. If the stimulus is VBUS is ready to be applied or applied (i.e., CS1_STIMX[2:0] = 000b or 111b), the threshold value is ignored.

10.13.5 Custom Stimulus / Response Pair X - Config 4 - 44h, 48h, 4Ch

The contents of this register are retained in Sleep.

Bits 2 - 0 - CS1_SX_RATIO[2:0] - Determines the voltage divider ratio, as shown in [Table 10.36](#), when the stimulus response is set to connect a voltage divider (i.e., CS1_SX_RX[3:0] = 0110b, 1001b, or 1100b).

10.14 Current Limiting Behavior Configuration Registers

Table 10.38 Current Limit Behavior Configuration Registers

ADDR	R/W	REGISTER	B7	B6	B5	B4	B3	B2	B1	B0	DEFAULT
50h	R	Applied Current Limiting Behavior	SEL_VBUS_MIN[1:0] (V_{BUS_MIN})	-	-	SEL_R2_IMIN[2:0] (I_{BUS_R2MIN} as shown in Figure 7.2)	-	-	1	0	82h
51h	R/W	Custom Current Limiting Behavior Config	CS_VBUS_MIN [1:0] (V_{BUS_MIN})	-	-	CS_R2_IMIN[2:0] (I_{BUS_R2MIN} as shown in Figure 7.2)	-	-	1	0	82h

10.14.1 Applied Current Limiting Behavior - 50h

This register stores the values used by the applied current limiting mode (trip or CC) when the custom settings are not used. The contents of this register are updated automatically when charger emulation is completed.

The contents of this register are not retained in Sleep. The contents are updated as needed.

Bits 7 - 6 - SEL_VBUS_MIN[1:0] - Define the V_{BUS_MIN} voltage as shown in [Table 10.39](#).

Bits 4 - 2 - SEL_R2_IMIN[2:0] - Define the I_{BUS_R2MIN} current as shown in [Table 10.40](#).

Bits 1 - 0 - RESERVED.

10.14.2 Custom Current Limiting Behavior Configuration - 51h

The Custom Current Limiting Behavior Configuration register allows programming of current limit parameters. These controls are used when a portable device handshakes using the Legacy charger emulation profiles (except Legacy 2), the Custom charger emulation profile, or does not handshake as a dedicated charger (i.e., a power thief).

The contents of this register are retained in Sleep.

Bits 7 - 6 - CS_VBUS_MIN[1:0] - Defines the Custom V_{BUS_MIN} voltage as shown in [Table 10.39](#). Note that V_{BUS_MIN} is checked even when operating with trip current limiting.

Table 10.39 V_{BUS_MIN} Threshold Options

X_VBUS_MIN[1:0]		V _{BUS_MIN} VALUE
1	0	
0	0	1.5 V
0	1	1.75 V
1	0	2.0 V (default)
1	1	2.25 V

Bits 4 - 2 - CS_R2_IMIN[2:0] - Define the Custom I_{BUS_R2MIN} threshold as shown in Table 10.40. The default is 100 mA. This value is used under the following conditions: when a portable device handshakes using the Legacy charger emulation profiles (except Legacy 2) or the Custom charger emulation profile, or when it does not handshake in DCE Cycle (i.e., a power thief). Under these conditions, the current limiting mode is determined by the relative value of I_{BUS_R2MIN} and ILIM. When I_{BUS_R2MIN} ≤ ILIM or ILIM > 1.5 A, trip current limiting used; otherwise, CC mode is used.

Bits 1 - 0 - RESERVED - Do not change.

Table 10.40 I_{BUS_R2MIN} Threshold Options

X_R2_IMIN[2:0]			I _{BUS_R2MIN} VALUE
2	1	0	
0	0	0	100 mA
0	0	1	500 mA
0	1	0	900 mA
0	1	1	1200 mA
1	0	0	1500 mA
1	0	1	1800 mA

10.15 Product ID Register

Table 10.41 Product ID Register

ADDR	R/W	REGISTER	B7	B6	B5	B4	B3	B2	B1	B0	DEFAULT
FDh	R	Product ID	0	1	0	0	1	1	1	0	4Eh

The Product ID register stores a unique 8-bit value that identifies the device.

10.16 Manufacturer ID Register

Table 10.42 Manufacturer ID Register

ADDR	R/W	REGISTER	B7	B6	B5	B4	B3	B2	B1	B0	DEFAULT
FEh	R	Manufacturer ID	0	1	0	1	1	1	0	1	5Dh

The Manufacturer ID register stores a unique 8-bit value that identifies SMSC.

10.17 Revision Register

Table 10.43 Revision Register

ADDR	R/W	REGISTER	B7	B6	B5	B4	B3	B2	B1	B0	DEFAULT
FFh	R	Revision	1	0	0	0	0	0	1	0	82h

The Revision register stores an 8-bit value that represents the part revision.

Chapter 11 Package Information

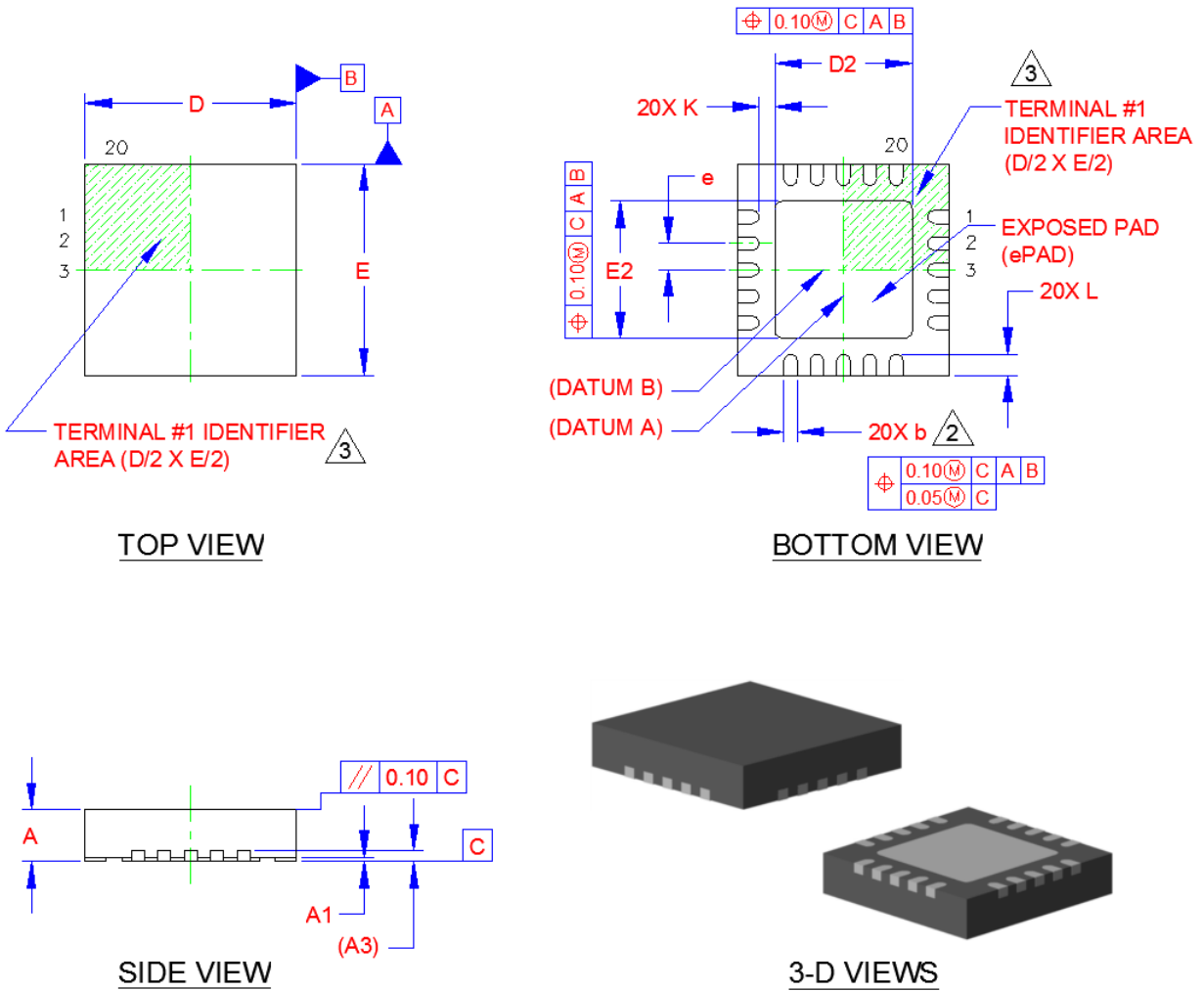

Figure 11.1 UCS1002 Package View

COMMON DIMENSIONS					
SYMBOL	MIN	NOM	MAX	NOTE	REMARK
A	0.80	0.85	0.90	-	OVERALL PACKAGE HEIGHT
A1	0	0.02	0.05	-	STANDOFF
A3	0.20 REF			-	LEAD-FRAME THICKNESS
D/E	3.90	4.00	4.10	-	X/Y BODY SIZE
D2/E2	2.50	2.60	2.70	-	X/Y EXPOSED PAD SIZE
L	0.30	0.40	0.50	-	TERMINAL LENGTH
b	0.18	0.25	0.30	2	TERMINAL WIDTH
K	0.25	0.30	-	-	TERMINAL TO PAD DISTANCE
e	0.50 BSC			-	TERMINAL PITCH

NOTES:

1. ALL DIMENSIONS ARE IN MILLIMETERS.
2. DIMENSIONS "b" APPLIES TO PLATED TERMINALS AND IT IS MEASURED BETWEEN 0.15 AND 0.30 mm FROM THE TERMINAL TIP.
3. DETAILS OF TERMINAL #1 IDENTIFIER ARE OPTIONAL BUT MUST BE LOCATED WITHIN THE AREA INDICATED.

Figure 11.2 UCS1002 Package Dimensions and Notes

Chapter 12 Typical Operating Curves

Figure 12.1 USB-IF High-speed Eye Diagram (without data switch)

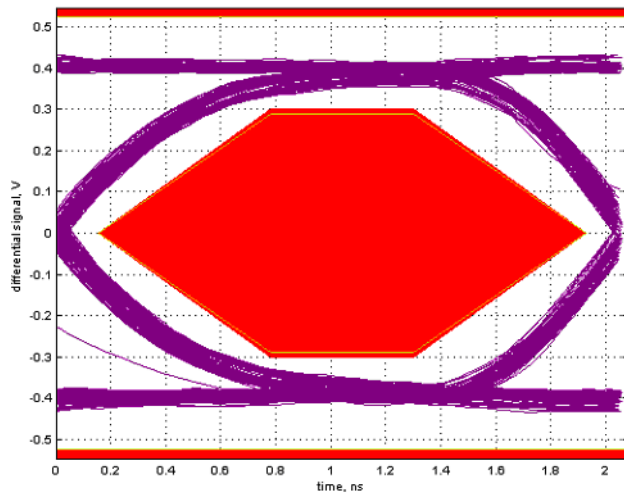

Figure 12.2 USB-IF High-speed Eye Diagram (with data switch)

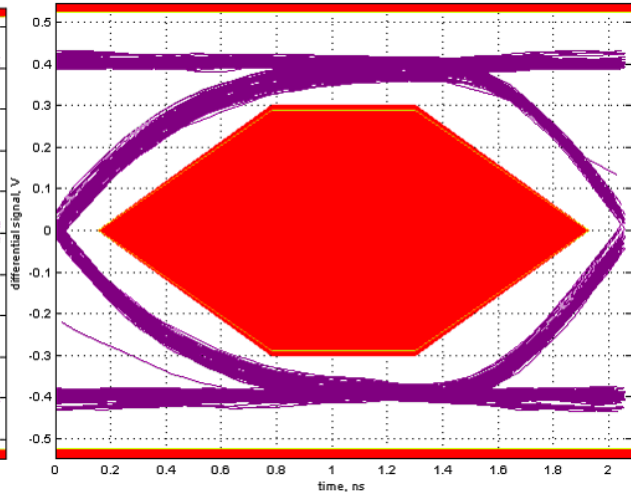

Figure 12.3 Short Applied After Power Up

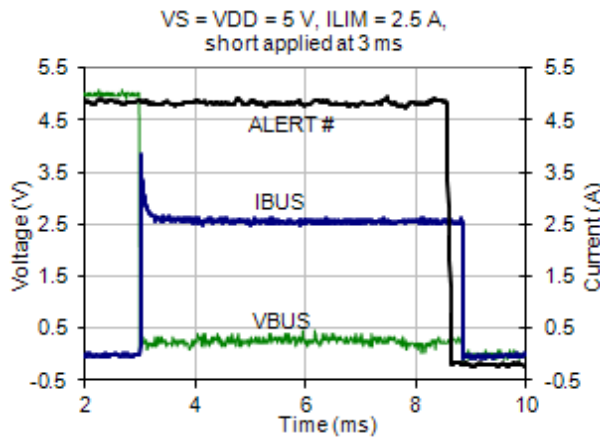

Figure 12.4 Power Up Into A Short

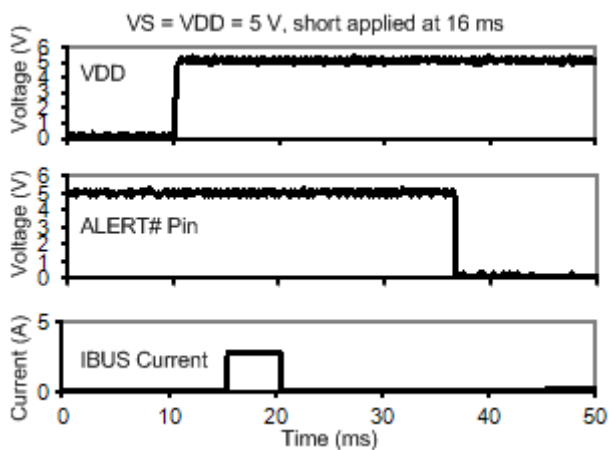

Figure 12.5 Internal Power Switch Short Response

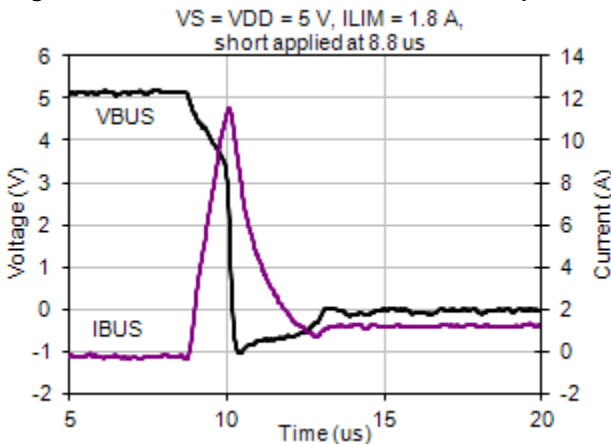

Figure 12.6 VBUS Discharge Behavior

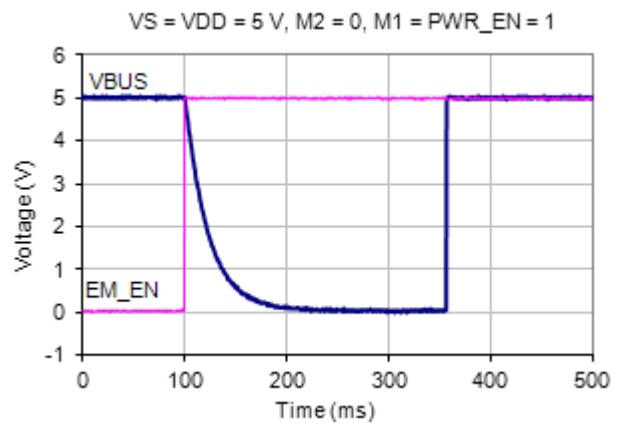

Figure 12.7 Data Switch Off Isolation vs. Frequency

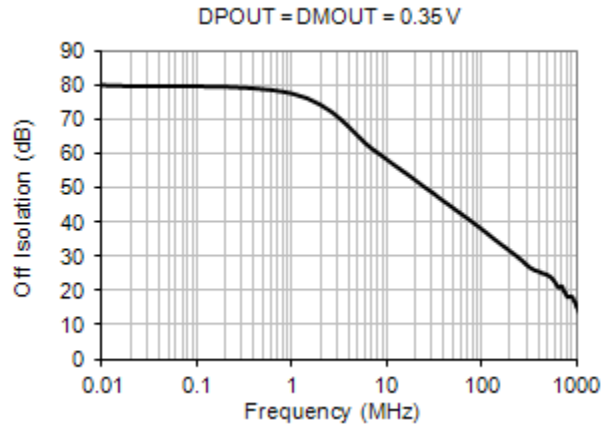

Figure 12.8 Data Switch Bandwidth vs. Frequency

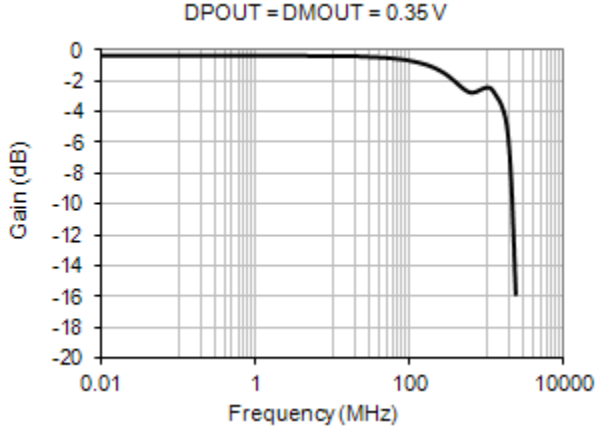

Figure 12.9 Data Switch On Resistance vs. Temp

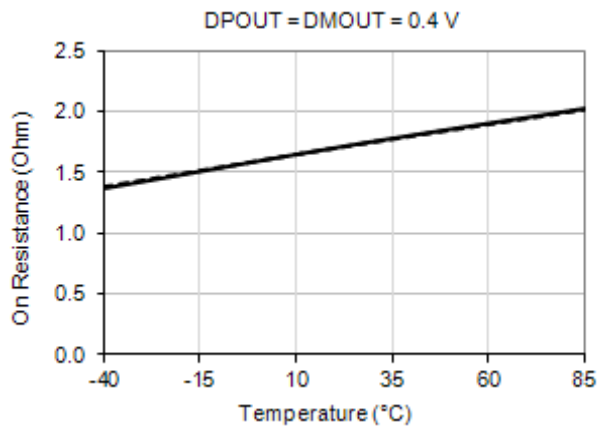

Figure 12.10 Power Switch On Resistance vs. Temp

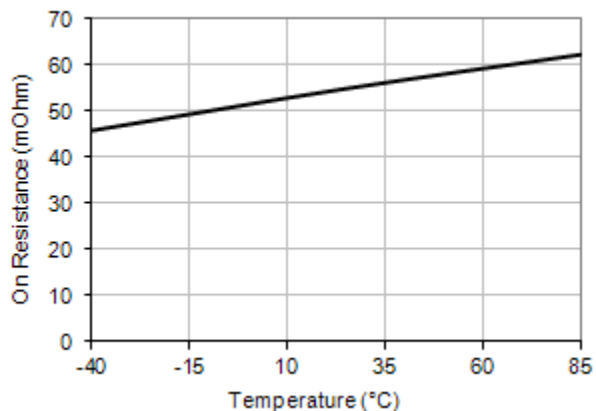

Figure 12.11 R_{DCP_RES} Resistance vs.Temp

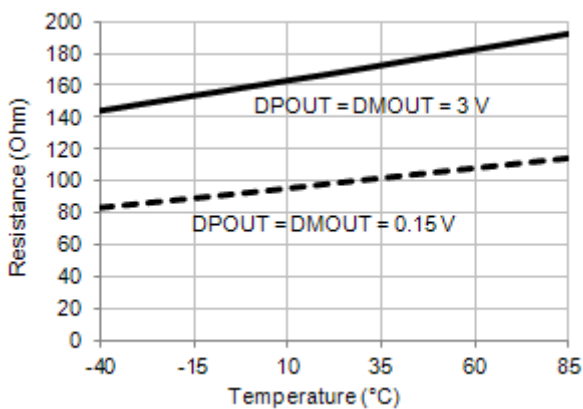

Figure 12.12 Power Switch On / Off Time vs. Temp

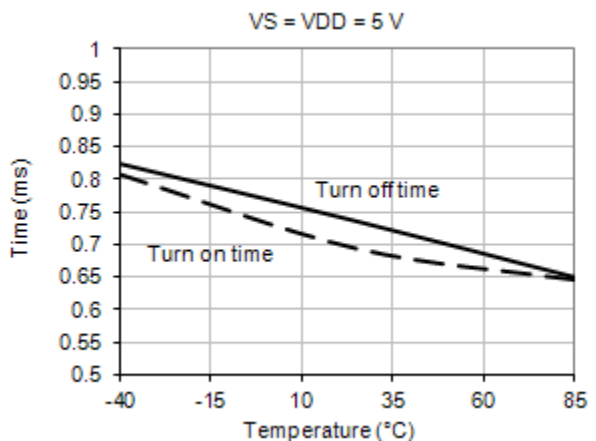

Figure 12.13 VS Over-Voltage Threshold vs. Temp

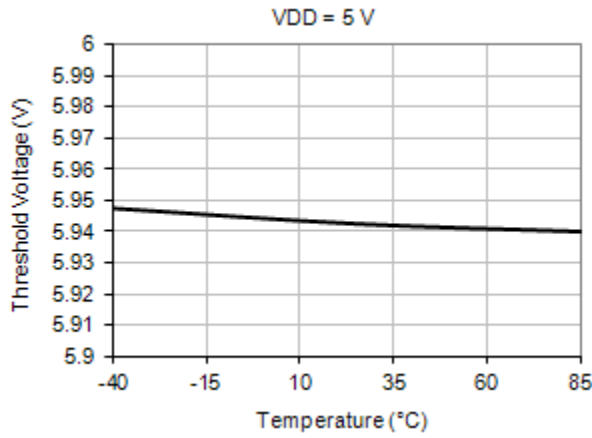

Figure 12.14 VS Under Voltage Threshold vs. Temp

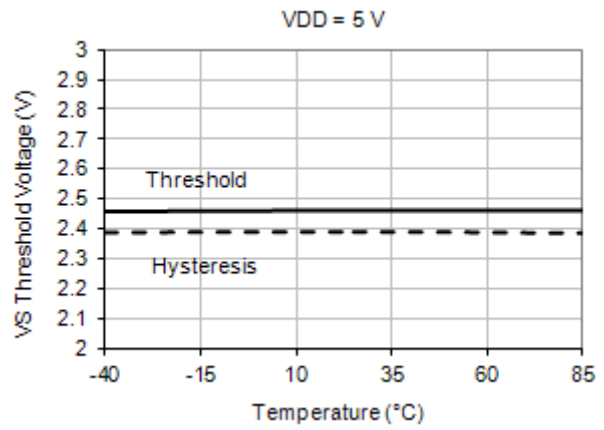

Figure 12.15 Detect State VBUS vs. IBUS

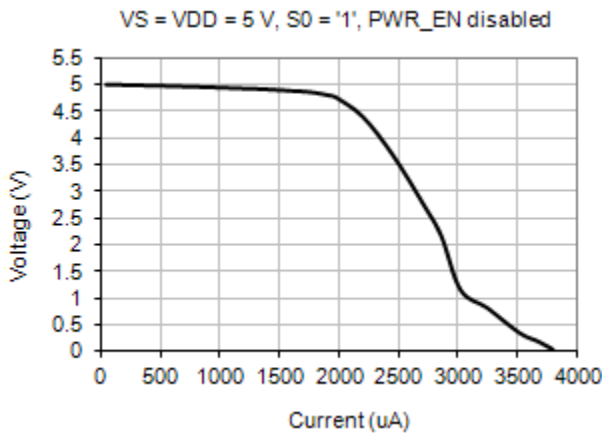

Figure 12.16 Trip Current Limit Operation vs. Temp.

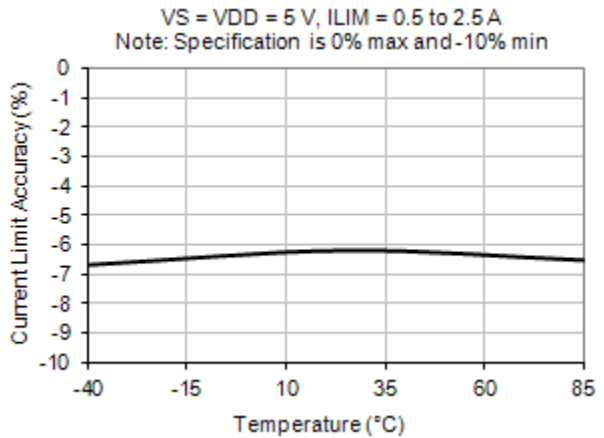

Figure 12.17 IBUS Measurement Accuracy

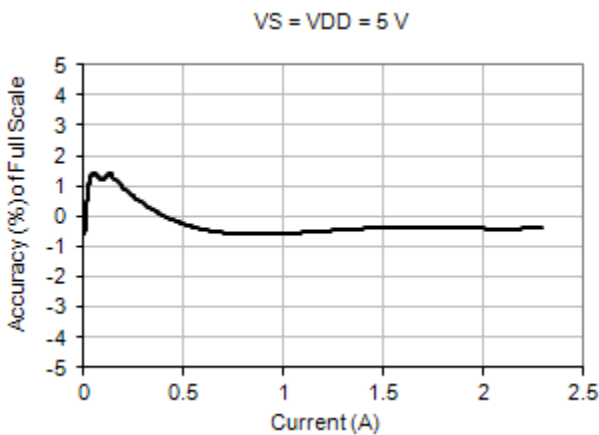

Figure 12.18 Active State Current vs. Temp

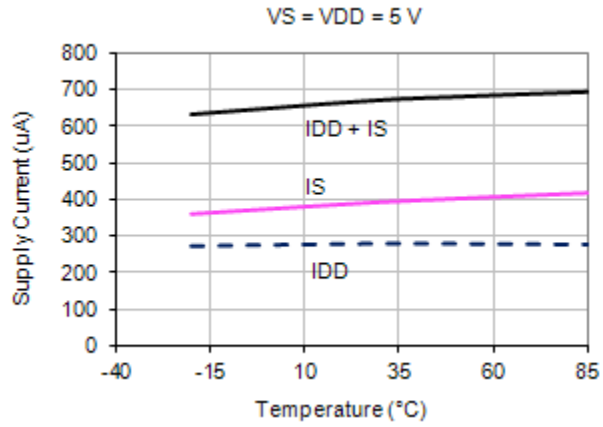

Figure 12.19 Detect State Current vs. Temp

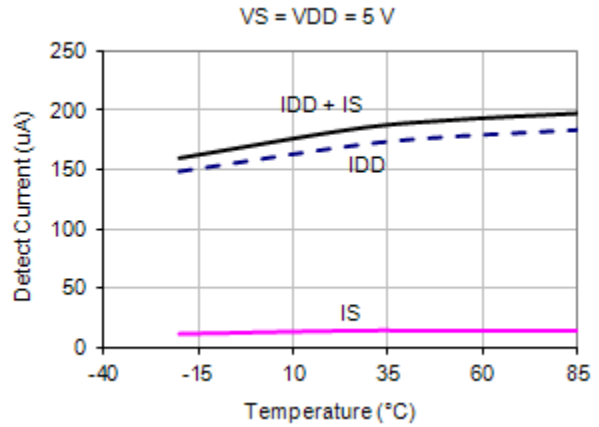
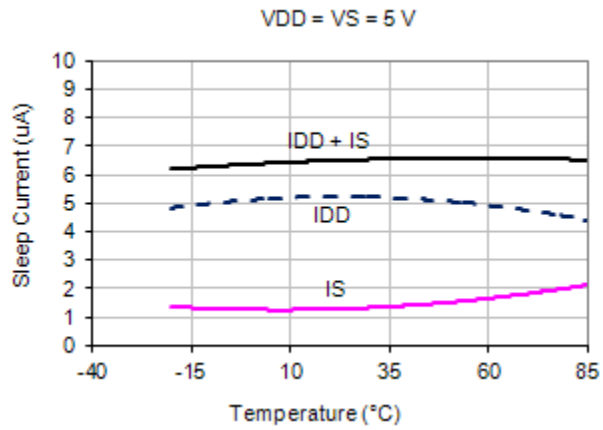

Figure 12.20 Sleep State Current vs. Temp



Chapter 13 References

For additional information, the following documents are available from your SMSC representative.

Application Note 24.14 Fundamentals of Custom Charger Emulation

Application Note 24.20 Using the UCS100x or UCS8100x as a Single or Dual Mode Charger

Application Note 25.0 UCS1002 Highest Current Algorithm Using an MCU

Application Note 25.4 UCS1002 Advanced Custom Charging

Application Note 25.5 UCS1002 Smart Battery Charger Hardware Reference Design

Application Note 25.7 UCS1002 Charge Rationing

Application Note 25.16 USB Charging Port ESD Protection Tips for UCS100x

Application Note 26.1 - UCS1002 Current Limit Operation and Features

UCS1002 FAQs (frequently asked questions)

UCS1002-1 Reference Design

UCS1001 / UCS1002 Production Test Method

Charger Test Report

Chapter 14 Document Revision History

Table 14.1 Customer Revision History

REVISION LEVEL & DATE	SECTION/FIGURE/ENTRY	CORRECTION
Revision 1.4 (07-16-13)	Cover	<ul style="list-style-type: none"> Added patent information to cover
		<ul style="list-style-type: none"> Title change from "USB Port Power Controller with Charger Emulation" to "Programmable USB Port Power Controller with Charger Emulation"
	Table 3.3, "Electrical Specifications"	<ul style="list-style-type: none"> Added specifications for I_{DET_QUAL} / I_{REM_QUAL} and I_{BUS_CHG}
	Section 9.8.2, "Emulation Cycling"	<ul style="list-style-type: none"> Updated text for DCE cycle behavior. Changed cycle order for 1001-3 and 1001-4.
	Section 10.4.4, "Attach Detection Configuration - 18h"	<ul style="list-style-type: none"> Changed register default setting for I_{DET_QUAL} / I_{REM_QUAL} default change from 45h to 46h
	Section 10.8, "IBUS_CHG Configuration Register"	<ul style="list-style-type: none"> Changed register default setting for I_{BUS_CHG} value change from 01h to 04h
Revision 1.3 (02-14-13)	Table 3.3, "Electrical Specifications"	<ul style="list-style-type: none"> Added Pin Wake Time (t_{PIN_WAKE}). Added SMBus Wake Time (t_{SMB_WAKE}) and Idle Sleep Time (t_{IDLE_SLEEP}). Added Timeout ($t_{TIMEOUT}$) and Idle Reset (t_{IDLE_RESET}). Changed I_{SLEEP} from 8 μA (MAX) to 15 μA (MAX) per characterization data. Added 12W Current Limit changes.
	Figure 5.5, "Wake Timing via External Pins"	<ul style="list-style-type: none"> Changed ~3ms to t_{PIN_WAKE}. Removed third example: "Wake with S0 & PWR_EN to Auto-transition Detect State ($V_S > V_{S_UVLO}$, M1 & M2 & EM_EN not all '0' and not set to Data Pass-through)".
	Figure "Wake Via SMBus Read with S0 = "0"	<ul style="list-style-type: none"> Changed >5ms to t_{IDLE_SLEEP}. Changed time between reads from $1ms < t < 5ms$ to t_{SMB_WAKE}.
	Chapter 5, General Description	<ul style="list-style-type: none"> After system diagrams, noted that a reference design is available.
	Chapter 14, Document Revision History	<ul style="list-style-type: none"> Added.
Revision 1.2 (05-21-12)	Cover	<ul style="list-style-type: none"> Certification added: "UL recognized and EN/IEC 60950-1 (CB) certified"
Revision 1.2 (05-16-12)	Cover	<ul style="list-style-type: none"> Source voltage: V_S MIN moved from 2.7 to 2.9 V to accommodate UL
	Table 3.3, "Electrical Specifications"	<ul style="list-style-type: none"> Source voltage: V_S MIN moved from 2.7 to 2.9 V to accommodate UL
	Cover	<ul style="list-style-type: none"> There are nine preloaded charger emulation profiles.

Table 14.1 Customer Revision History (continued)

REVISION LEVEL & DATE	SECTION/FIGURE/ENTRY	CORRECTION
	Chapter 2, Pin Description	<ul style="list-style-type: none"> ■ Changed “unused connection” to n/a for COMM_SEL / ILIM, SEL, SMDATA / LATCH, and SMCLK / S0 pins as they must be used. ■ Added Note 2.1: Total leakage current from pins 3 and 4 (VBUS) to ground must be less than 100 µA for proper attach / removal detection operation. ■ Added Note 2.2: It is recommended to use 2 MΩ pull-down resistors on the DPOUT and / or DMOUT pin if a portable device stimulus is expected when using the Custom charger emulation profile with the high-speed data switch open. The 2 MΩ value is based on BC1.1 impedance characteristics for Dedicated Charging Ports.
	Table 3.3, "Electrical Specifications"	<ul style="list-style-type: none"> ■ I_{DET_QUAL} changed from 200 µA to 400 µA. ■ I_{REM_QUAL_DET} changed from 200 µA to 400 µA. ■ I_{REM_QUAL_ACT} changed from 100 µA to 300 µA. ■ Updated selectable current limits (ILIMx) min and max values. Typical values did not change. ■ Changed I_{ACTIVE} from 500 µA (TYP) to 650 µA (TYP). ■ Changed I_{ACTIVE} from TBD µA (MAX) to 750 µA (MAX). ■ Changed I_{SLEEP} from TBD µA (MAX) to 8 µA (MAX). ■ Changed I_{DETECT} from 190 µA (TYP) to 185 µA (TYP). ■ Changed I_{DETECT} from TBD µA (MAX) to 220 µA (MAX). ■ Removed V_{S_OV} MIN value (5.6 V) and MAX value (TBD). ■ Changed R_{ON_PSW} from 70 mΩ (MAX) to 65 mΩ (MAX). ■ Changed I_{LEAK_VS} from TBD µA (MAX) to 5 µA (MAX). ■ Changed I_{LEAK_BYP} from 0.5 µA (MAX) to 3 µA (MAX). ■ Changed I_{BD_1} from 2 µA (MAX) to 3 µA (MAX).
	Section 4.1, "Operating Mode"	<ul style="list-style-type: none"> ■ Added. Moved Table 4.1, "UCS1002 Communication Mode and ILIM Selection" here (it was in Section 4.3, "Stand-alone Operating Mode").
	Table 5.1, "Power States Control Settings"	<ul style="list-style-type: none"> ■ “Behavior” cell in the “Sleep” row: Clarified behavior by adding “VBUS will be near ground potential”.
	Section 5.1.2, "Sleep State Operation"	<ul style="list-style-type: none"> ■ Clarified behavior by adding “VBUS will be near ground potential”.
	Section 5.2.3, "Back-voltage Detection" and Section 5.2.4, "Back-drive Current Protection"	<ul style="list-style-type: none"> ■ Section “Back-voltage / Back-drive Detection” split into two. ■ In Section 5.2.4, "Back-drive Current Protection", corrected reference I_{BD_LK} to match elec spec symbol I_{BD_1} and rewrote back-drive description.
	Section 7.2.4, "Current Limiting Modes"	<ul style="list-style-type: none"> ■ Added: The current limiting mode used depends on the Active state mode (see Section 9.9, "Current Limit Mode Associations").
	Section 7.2.4.1, "Trip Mode"	<ul style="list-style-type: none"> ■ Added application note: To avoid cycling in trip mode, set ILIM higher than the highest expected portable device current draw.

Table 14.1 Customer Revision History (continued)

REVISION LEVEL & DATE	SECTION/FIGURE/ENTRY	CORRECTION
	Table 9.2, "Current Limit Mode Options"	<ul style="list-style-type: none"> ■ Rearranged rows so DCE Cycle is grouped together. ■ Added row for DCE Cycle when a charger emulation profile is being applied. ■ For Legacy charger emulation profiles 1 and 3-7 and the Custom profile, the current limiting behavior used when the profile is accepted is also used if the timeout is disabled when the profile is applied during the DCE cycle. ■ Added text below table: As noted in the last three rows in Table 9.2, under those specific conditions with $ILIM \leq 1.5$ A, it is the relationship of $ILIM$ and I_{BUS_R2MIN} that determines the current limiting mode. In these cases, the value of I_{BUS_R2MIN} is determined by $CS_R2_IMIN[2:0]$ bits 4-2 in the Custom Current Limiting Behavior Configuration register 51h.
	Section 9.8.2, "Emulation Cycling" and Section 9.11.5, "Legacy 7 Charger Emulation Profile"	<ul style="list-style-type: none"> ■ Legacy 7 charger emulation profile defined and enabled by default.
	Section 10.4, "Configuration Registers" and Table 10.10, "Attach / Removal Detection Threshold Options"	<ul style="list-style-type: none"> ■ $ATT_TH[1:0]$ default changed from 200 μA to 400 μA. 18h register default changed from 44h to 45h.
	Section 10.10.2, "Legacy Emulation Enable - 21h"	<ul style="list-style-type: none"> ■ Legacy 7 charger emulation profile enabled by default. Register 21h default changed from 40h to 00h.
	Section 10.14.2, "Custom Current Limiting Behavior Configuration - 51h"	<ul style="list-style-type: none"> ■ Clarified description of $CS_R2_IMIN[2:0]$.
	Chapter 12, Typical Operating Curves	<ul style="list-style-type: none"> ■ Rearranged order of TOCs. ■ Added new TOCs: <ul style="list-style-type: none"> — Figure 12.3, "Short Applied After Power Up" — Figure 12.5, "Internal Power Switch Short Response" — Figure 12.16, "Trip Current Limit Operation vs. Temp." — Figure 12.17, "IBUS Measurement Accuracy" — Figure 12.18, "Active State Current vs. Temp" — Figure 12.19, "Detect State Current vs. Temp" — Figure 12.20, "Sleep State Current vs. Temp" ■ Updated the following: <ul style="list-style-type: none"> — Figure 12.6, "VBUS Discharge Behavior" — Figure 12.11, "RDCP_RES Resistance vs.Temp" — Figure 12.13, "VS Over-Voltage Threshold vs. Temp" — Figure 12.14, "VS Under Voltage Threshold vs. Temp" — Figure 12.15, "Detect State VBUS vs. IBUS"
Revision 1.1 (11-21-11)	Table 3.2, "Power Dissipation Summary"	<ul style="list-style-type: none"> ■ Missing units added.

Table 14.1 Customer Revision History (continued)



REVISION LEVEL & DATE	SECTION/FIGURE/ENTRY	CORRECTION
	Table 3.3, "Electrical Specifications"	<ul style="list-style-type: none"> ■ Changed t_{DET_CHARGE} from 400 ms to 800 ms typ and changed condition from $C_{BUS} = 220 \mu F$ to $C_{BUS} = 500 \mu F$ max. ■ VS Leakage Current changed from 0.8 μA typical to 2.2 μA. ■ Changed I_{BD_1} and I_{BD_2} from TBD typ to 0 μA typ and from 1.5 μA max to 2 μA max ■ Changed I_{TST} to I_{TEST} and changed typ from 165 to 190 mA. ■ Changed t_{ON_PSW} from 3 ms to 0.75 ms typical and $t_{OFF_PSW_INA}$ from 1 ms to 0.75 ms typical. ■ Spec changed for t_{HD_DAT}. 0 μs min has condition when transmitting to master. New row added with 0.3 μs min with condition when receiving from master. ■ New characteristic: Bus Free Time to Start, Start Setup Time, Hold Time, Setup Time, Clock Low Period, Clock High Period Data Fall Time -> Clock / Data Fall Time Data Rise Time -> Clock / Data Rise Time
	Table 3.4, "ESD Ratings"Section 3.1	<ul style="list-style-type: none"> ■ Charged Device Model: changed from 200 V to 500 V
	Section 4.2.2	<ul style="list-style-type: none"> ■ Differences between SMBus and I²C revised.
	Note 5.1	<ul style="list-style-type: none"> ■ Added note: In order to transition from Active state Data Pass-through mode into Sleep with these settings, change the M1, M2, and EM_EN pins before changing the PWR_EN pin.
	Table 5.1, "Power States Control Settings", Section 5.1.2, "Sleep State Operation", Section 6.1, "USB High-speed Data Switch"	<ul style="list-style-type: none"> ■ The high-speed switch is open in Sleep.
	Section 5.2.2, "VS Source Voltage"	<ul style="list-style-type: none"> ■ Added.
	Section 4.2.4	<ul style="list-style-type: none"> ■ New section I²C Protocols, covering sections Block Write and Block Read moved from Section 4.2.3.
	Section 10.4.2, "Emulation Configuration - 16h"	<ul style="list-style-type: none"> ■ Added application note regarding EM_TIMEOUT_DIS: If the EM_TIMEOUT_DIS bit is set and the Legacy 1, Legacy 3, or Custom charger emulation profiles were accepted during the DCE cycle, a removal is not detected. To avoid this issue, re-enable the timeout after applying any test profiles and charging with the 'final' profile.
	Section 10.13.1, "Custom Emulation Configuration - 40h"	<ul style="list-style-type: none"> ■ Added application note regarding CS1_TIMEOUT_DIS: If the CS1_TIMEOUT_DIS bit is set and the Custom charger emulation profile was accepted during the DCE cycle, a removal is not detected. To avoid this issue, re-enable the timeout after applying any test profiles and charging with the 'final' profile.
	Cover, Section 9.11.3, "Legacy 1, 3, 4, and 6 Charger Emulation Profiles"	<ul style="list-style-type: none"> ■ Legacy 6 profile has been defined.
	Section 10.11.3, "Legacy Emulation Timeout Config 2 - 24h"	<ul style="list-style-type: none"> ■ Register 24h default changed from 00h to 04h (Legacy 6 timeout 1.6 s).

Table 14.1 Customer Revision History (continued)

REVISION LEVEL & DATE	SECTION/FIGURE/ENTRY	CORRECTION
Revision 1.1 (11-21-11) cont.	Section 9.4, "Data Pass-through (No Charger Emulation)"	<ul style="list-style-type: none"> ■ Data Pass-through persists until M1, M2, or EM_EN controls are changed. It is no longer affected by PWR_EN. Added application note: When the M1, M2, and EM_EN controls are set to '0', '1', '0' or to '1', '1', '0' respectively, Data Pass-through mode will persist if the PWR_EN control is disabled; however, the UCS1002 will draw more current. To leave Data Pass-through mode, the PWR_EN control must be enabled before the M1, M2, and EM_EN controls are changed to the desired mode.
	Section 9.6, "BC1.2 CDP"	<ul style="list-style-type: none"> ■ BC1.2 CDP mode uses constant current limiting. Added application note: BC1.2 compliance testing may require the S0 control to be set to '0' (Attach and Removal Detection feature disabled) while testing is in progress. ■ Added application note: When the UCSX100X is in BC1.2 CDP mode and the Attach and Removal Detection feature is enabled, if a power thief, such as a USB light or fan, attaches but does not assert DP, a Removal event will not occur when the portable device is removed. However, if a standard USB device is subsequently attached, Removal Detection will again be fully functional. As well, if PWR_EN is cycled or M1, M2, and / or EM_EN change state, a Removal event will occur and Attach Detection will be reactivated.
	Section 9.7, "BC1.2 DCP"	<ul style="list-style-type: none"> ■ Added application note: BC1.2 compliance testing may require the S0 control to be set to '0' (Attach and Removal Detection feature disabled) while testing is in progress.
	Table 9.2, "Current Limit Mode Options"	<ul style="list-style-type: none"> ■ BC1.2 CDP charger emulation changed from using "trip" to "CC mode if ILIM < 1.5 A, otherwise, trip mode".
	Section 9.11.4, "Legacy 5 Charger Emulation Profile"	<ul style="list-style-type: none"> ■ Added. The Legacy 5 charger emulation profile no longer applies a voltage divider. It applies 900 mV to DPOUT and DMOUT.
Revision 1.0 (08-18-11)	Initial Release	

Looking for pricing, stock, or lifecycle information?

Click below to explore more details on WIN SOURCE:

-  [View UCS1002-1-BP-TR on WIN SOURCE](#)
-  [Microchip Technology](#) Information

Optimize Your Supply Chain with WIN SOURCE Solutions

-  Global Sourcing Solution
-  Obsolete Management
-  Cost Control Management
-  Shortage Management
-  Alternative Solution
-  Excess Inventory Management