



**THE DATASHEET OF
ADS850Y/250**





14-Bit, 10MSPS Self-Calibrating ANALOG-TO-DIGITAL CONVERTER

FEATURES

- SELF-CALIBRATING
- HIGH SFDR: 85dB at NYQUIST
- HIGH SNR: 76dB
- LOW POWER: 250mW
- DIFFERENTIAL OR SINGLE-ENDED INPUTS
- +3V/+5V LOGIC I/O COMPATIBLE
- FLEXIBLE INPUT RANGE
- OVER-RANGE INDICATOR
- INTERNAL OR EXTERNAL REFERENCE

APPLICATIONS

- IF AND BASEBAND DIGITIZATION
- CCD IMAGING SCANNERS
- TEST INSTRUMENTATION
- IR IMAGING

DESCRIPTION

The ADS850 is a high dynamic range, 14-bit Analog-to-Digital Converter (ADC) that utilizes a fully differential input, allowing for either single-ended or differential input interface over varying input spans. This converter features digital error correction techniques ensuring 14-bit linearity and a calibration procedure that corrects for capacitor and gain mismatches. The ADS850 also includes a high-bandwidth track-and-hold that provides excellent spurious performance up to and beyond the Nyquist rate.

The ADS850 provides an internal reference that can be programmed for a 2Vp-p input range for the best spurious performance and ease of driving. Alternatively, the 4Vp-p input range can be used for the lowest input referred noise, offering superior signal-to-noise performance for imaging applications. There is also the capability to set the range between 2Vp-p and 4Vp-p, or to use an external reference. The ADS850 also provides an over-range indicator flag to indicate if the input has exceeded the full-scale input range of the converter.

The low distortion and high signal-to-noise performance provide the extra margin needed for communications, imaging, and test instrumentation applications. The ADS850 is available in a TQFP-48 package.

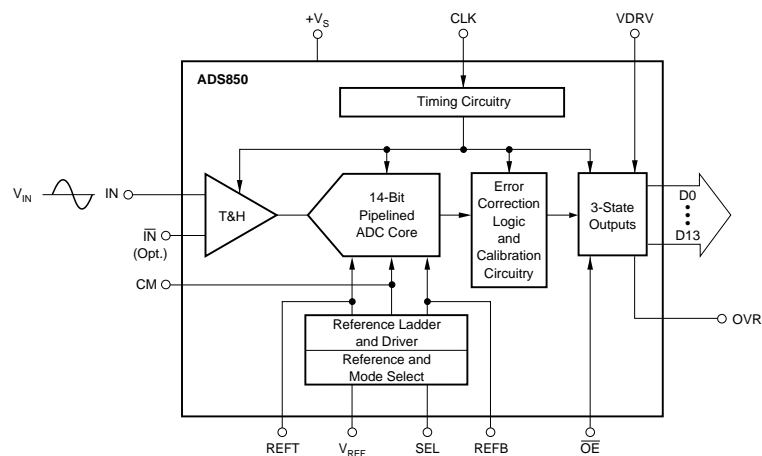

Please be aware that an important notice concerning availability, standard warranty, and use in critical applications of Texas Instruments semiconductor products and disclaimers thereto appears at the end of this data sheet.

ABSOLUTE MAXIMUM RATINGS⁽¹⁾

+V _S	+6V
Analog Input	(-0.3V) to (+V _S +0.3V)
Logic Input	(-0.3V) to (+V _S +0.3V)
Case Temperature	+100°C
Junction Temperature	+150°C
Storage Temperature	+150°C

NOTE: (1) Stresses above those listed under "Absolute Maximum Ratings" may cause permanent damage to the device. Exposure to absolute maximum conditions for extended periods may affect device reliability.

DEMO BOARD ORDERING INFORMATION

PRODUCT	DEMO BOARD
ADS850Y	ADS850Y-EVM



ELECTROSTATIC DISCHARGE SENSITIVITY

This integrated circuit can be damaged by ESD. Texas Instruments recommends that all integrated circuits be handled with appropriate precautions. Failure to observe proper handling and installation procedures can cause damage.

ESD damage can range from subtle performance degradation to complete device failure. Precision integrated circuits may be more susceptible to damage because very small parametric changes could cause the device not to meet its published specifications.

PACKAGE/ORDERING INFORMATION

PRODUCT	PACKAGE-LEAD	PACKAGE DESIGNATOR ⁽¹⁾	SPECIFIED TEMPERATURE RANGE	PACKAGE MARKING	ORDERING NUMBER	TRANSPORT MEDIA, QUANTITY
ADS850Y	TQFP-48	PFB	-40°C to +85°C	ADS850Y	ADS850Y/250	Tape and Reel, 250
"	"	"	"	"	ADS850Y/2K	Tape and Reel, 2000

NOTE: (1) For the most current specifications and package information, refer to our web site at www.ti.com.

ELECTRICAL CHARACTERISTICS

At T_A = full specified temperature range, V_S = +5V, specified differential input range = 1.5V to 3.5V, internal reference input, sampling rate = 10MSPS after calibration, and V_{REF} = 2V, unless otherwise specified.

PARAMETER	CONDITIONS	ADS850Y			UNITS
		MIN	TYP	MAX	
RESOLUTION			14		Bits
SPECIFIED TEMPERATURE RANGE			-40 to +85		°C
CONVERSION CHARACTERISTICS					
Sample Rate		10k		10M	Samples/s
Data Latency			7		Clk Cycles
ANALOG INPUT					
Single-Ended Input Range	V _{REF} = 1.0	1.5		3.5	V
	V _{REF} = 2.0	0.5		4.5	V
Differential Input Range	V _{REF} = 2.0	1.5		3.5	V
Common-Mode Voltage			2.5		V
Input Capacitance			1		V
Analog Input Bandwidth	-3dBFS Input		20		pF
			270		MHz
DYNAMIC CHARACTERISTICS					
Differential Linearity Error (Largest Code Error)					
f = 4.8MHz			±0.75	±1.0	LSB
No Missing Codes			Tested		
Spurious-Free Dynamic Range ⁽¹⁾					
f = 4.8MHz (-1dB input)	4Vp-p	75	85		dBFS ⁽²⁾
f = 4.8MHz (-1dB input)	2Vp-p		82		dBFS
Signal-to-Noise Ratio (SNR)					
f = 4.8MHz (-1dB input)	4Vp-p	71	76		dBFS
f = 4.8MHz (-1dB input)	2Vp-p		73		dBFS
Signal-to-(Noise + Distortion) (SINAD)					
f = 4.8MHz (-1dB input)	4Vp-p	70	75		dBFS
f = 4.8MHz (-1dB input)	2Vp-p		72		dBFS
Effective Number of Bits at 4.8MHz ⁽³⁾			12.2		Bits
Integral Nonlinearity Error					
f = 4.8MHz			±2.5	±5.0	LSB
Aperture Delay Time			1		ns
Aperture Jitter			4		ps rms
Overvoltage Recovery Time	1.5 • FS Input		2		ns
Full-Scale Step Acquisition Time			50		ns

ELECTRICAL CHARACTERISTICS (Cont.)

At T_A = full specified temperature range, $V_S = +5V$, specified differential input range = 1.5V to 3.5V, internal reference input, sampling rate = 10MSPS after calibration, and $V_{REF} = 2V$, unless otherwise specified.

PARAMETER	CONDITIONS	ADS850Y			UNITS
		MIN	TYP	MAX	
DIGITAL INPUTS Logic Family Convert Command High Level Input Current ($V_{IN} = 5V$) ⁽⁴⁾ Low Level Input Current ($V_{IN} = 0V$) High Level Input Voltage Low Level Input Voltage Input Capacitance	Start Conversion		+3V/+5V Logic Compatible CMOS Rising Edge of Convert Clock	100 ±10 +1.0	µA µA V V pF
DIGITAL OUTPUTS Logic Family Logic Coding Low Output Voltage Low Output Voltage High Output Voltage High Output Voltage 3-State Enable Time 3-State Disable Time Output Capacitance	($I_{OL} = 50\mu A$) ($I_{OL} = 1.6mA$) ($I_{OH} = 50\mu A$) ($I_{OH} = 0.5mA$) OE = LOW OE = HIGH	+4.5 +2.4	+3V/+5V Logic Compatible CMOS Straight Offset Binary	0.1 0.4 20 40 2 10 5	V V V V ns ns pF
ACCURACY (4Vp-p Input Range) Zero Error (Referred to –FS) Zero Error Drift (Referred to –FS) Gain Error ⁽⁵⁾ Gain Error Drift ⁽⁵⁾ Gain Error ⁽⁶⁾ Gain Error Drift ⁽⁶⁾ Power-Supply Rejection of Gain Reference Input Resistance Internal Voltage Reference Tolerance ($V_{REF} = 2.0V$) ⁽⁷⁾ Internal Voltage Reference Tolerance ($V_{REF} = 1.0V$) ⁽⁷⁾	At 25°C At 25°C At 25°C At 25°C $\Delta V_S = \pm 5\%$ At 25°C At 25°C		±0.2 ±5 ±0.7 ±15 ±0.042 ±15 82 1.6 ±13.5mV ±6mV	%FS ppm/°C %FS ppm/°C %FS ppm/°C dB kΩ mV mV	
POWER-SUPPLY REQUIREMENTS Supply Voltage: + V_S Supply Voltage: VDRV Supply Current: + I_S Power Dissipation VDRV = 3V VDRV = 5V VDRV = 3V VDRV = 5V Thermal Resistance, θ_{JA} TQFP-48	Operating Operating Operating External Reference External Reference Internal Reference Internal Reference Power-Down	+4.7 +2.7	+5.0 +5.3 53 240 245 250 255 20 56.5	+5.3 +5.3 275	V V mA mW mW mW mW mW °C/W

NOTES: (1) Spurious-Free Dynamic Range refers to the difference in magnitude between the fundamental and the next largest harmonic. (2) dBFS means dB relative to full scale. (3) Effective number of bits (ENOB) is defined by $(SINAD - 1.76)/6.02$. (4) Internal 50kΩ pull-down resistor. (5) Includes internal reference. (6) Excludes internal reference. (7) Typical reference tolerance based on ±1 sigma of distribution.

PIN CONFIGURATION

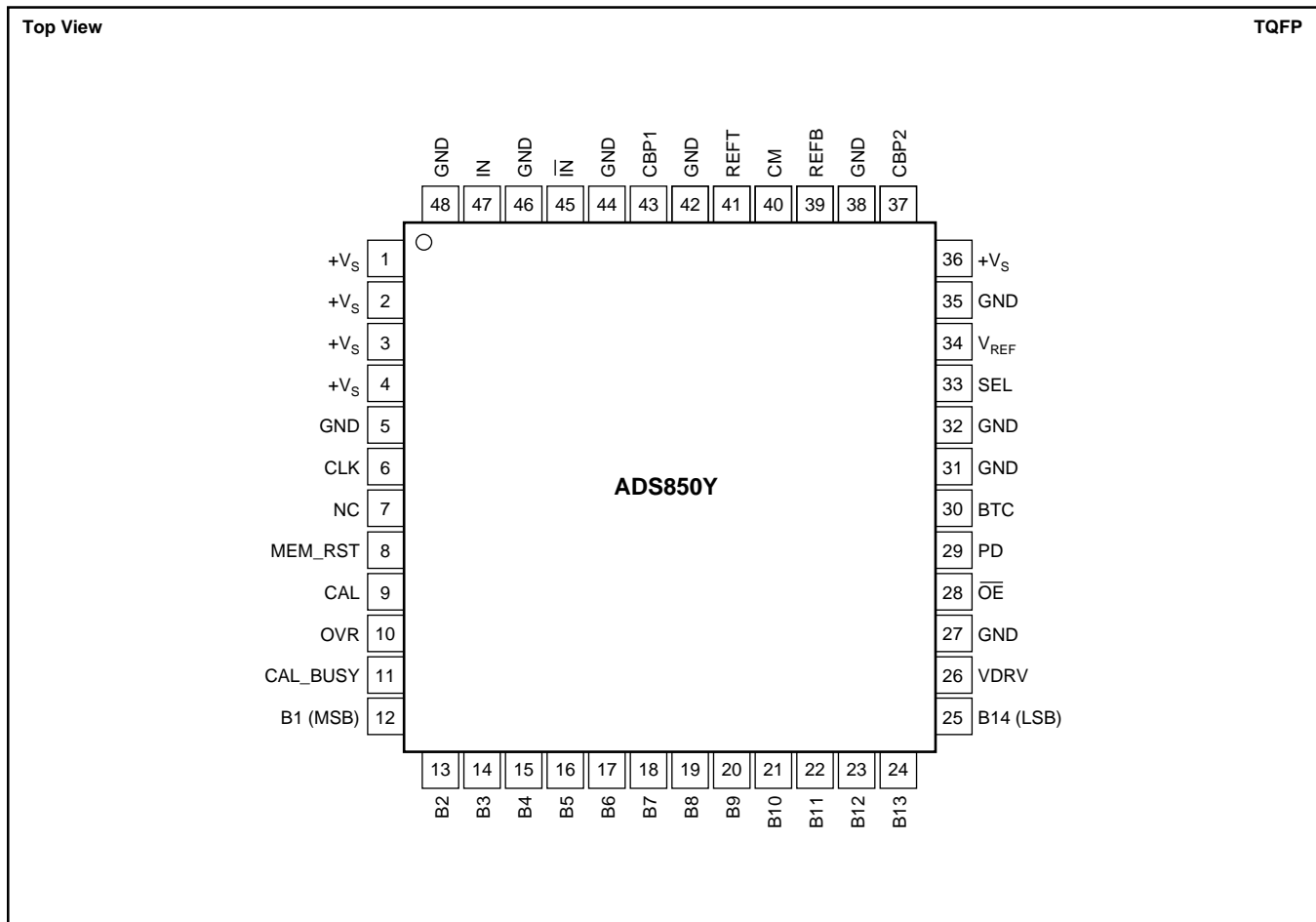

PIN DESCRIPTIONS

PIN	I/O	DESIGNATOR	DESCRIPTION	PIN	I/O	DESIGNATOR	DESCRIPTION
1		+V _S	+5V Supply	27		GND	Ground
2		+V _S	+5V Supply	28	I	OE	Output Enable: HI = High Impedance; LO = Normal Operation (50kΩ Internal Pull-Down Resistor)
3		+V _S	+5V Supply	29	I	PD	Power Down: HI = Power Down; LO = Normal Operation (50kΩ Internal Pull-Down Resistor)
4		+V _S	+5V Supply	30	I	BTC	HI = Binary Two's Complement (BTC); LO = Straight Offset Binary (SOB)
5		GND	Ground	31		GND	Ground
6	I	CLK	Convert Clock Input	32		GND	Ground
7		NC	No Connection	33		SEL	Input Range Select
8	I	MEM_RST	Memory Reset. When pulsed HIGH, resets memory to zero. Not intended as a function pin, so should be permanently tied to ground.	34	I/O	V _{REF}	Reference Voltage Select
9	I	CAL	When Pulsed High, puts ADC into Calibration Mode (2 clock cycles).	35		GND	Ground
10		OVR	Over Range Indicator	36		+V _S	+5V Supply
11		CAL_BUSY	Indicates in Calibration Mode.	37		CBP2	Calibration Reference Bypass 2 (0.1μF ceramic capacitor recommended for decoupling.)
12	O	B1 (MSB)	Data Bit 1 (D13) (MSB)	38		GND	Ground
13	O	B2	Data Bit 2 (D12)	39	I/O	REFB	Bottom Reference Voltage Bypass
14	O	B3	Data Bit 3 (D11)	40	O	CM	Common-Mode Voltage (mid-scale). Not intended for driving a load.
15	O	B4	Data Bit 4 (D10)	41	I/O	REFT	Top Reference Voltage Bypass
16	O	B5	Data Bit 5 (D9)	42		GND	Ground
17	O	B6	Data Bit 6 (D8)	43		CBP1	Calibration Reference Bypass 1 (0.1μF ceramic capacitor recommended for decoupling.)
18	O	B7	Data Bit 7 (D7)	44		GND	Ground
19	O	B8	Data Bit 8 (D6)	45	I	IN	Complementary Analog Input (-)
20	O	B9	Data Bit 9 (D5)	46		GND	Ground
21	O	B10	Data Bit 10 (D4)	47	I	IN	Analog Input (+)
22	O	B11	Data Bit 11 (D3)	48		GND	Ground
23	O	B12	Data Bit 12 (D2)				
24	O	B13	Data Bit 13 (D1)				
25	O	B14 (LSB)	Data Bit 14 (D0) (LSB)				
26		VDRV	Output Driver Voltage				

TIMING DIAGRAMS

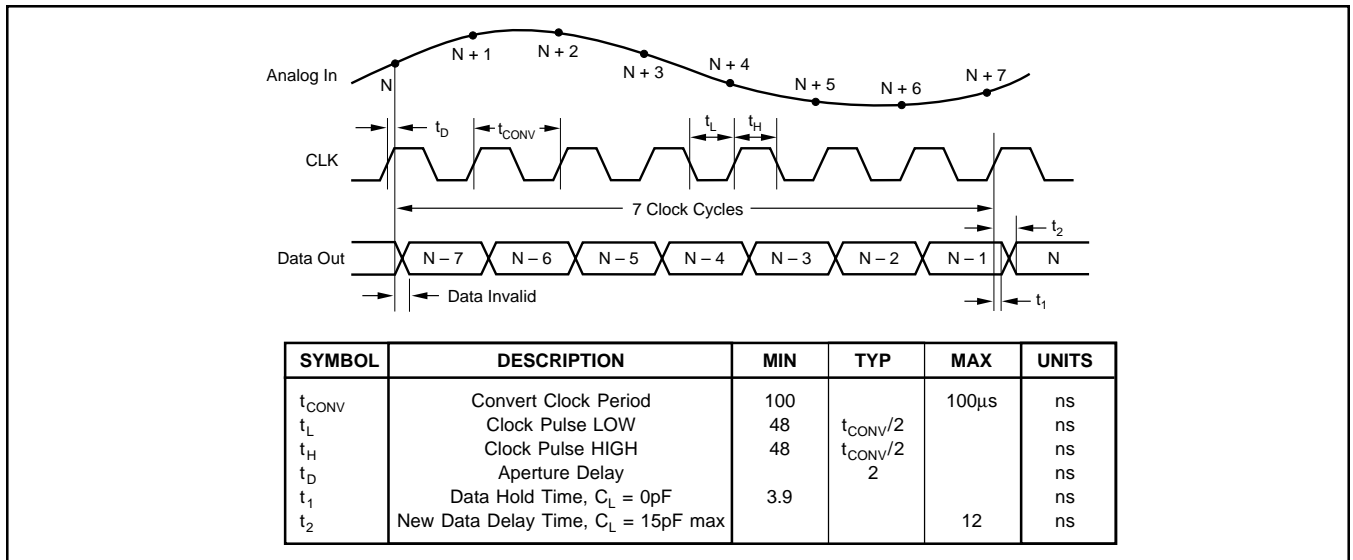

TIMING DIAGRAM 1. Pipeline Delay Timing.

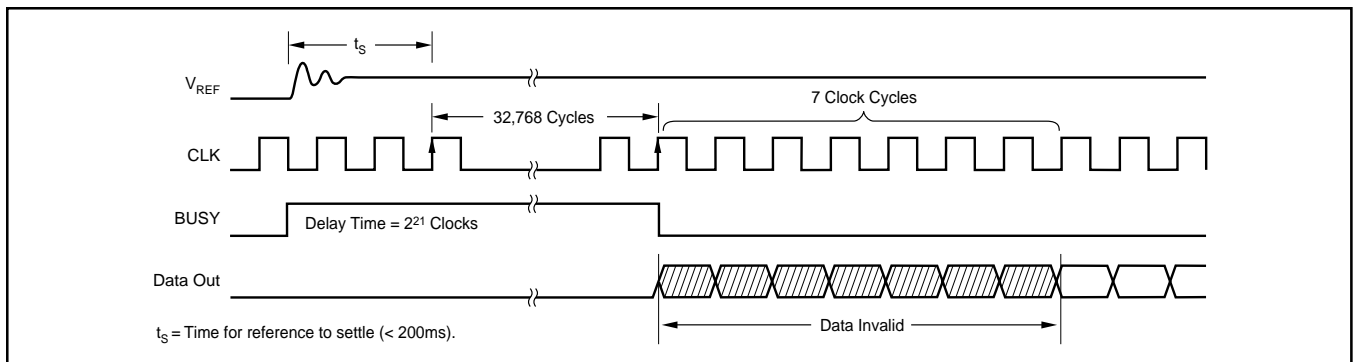

TIMING DIAGRAM 2. Power-On Calibration Mode Timing.

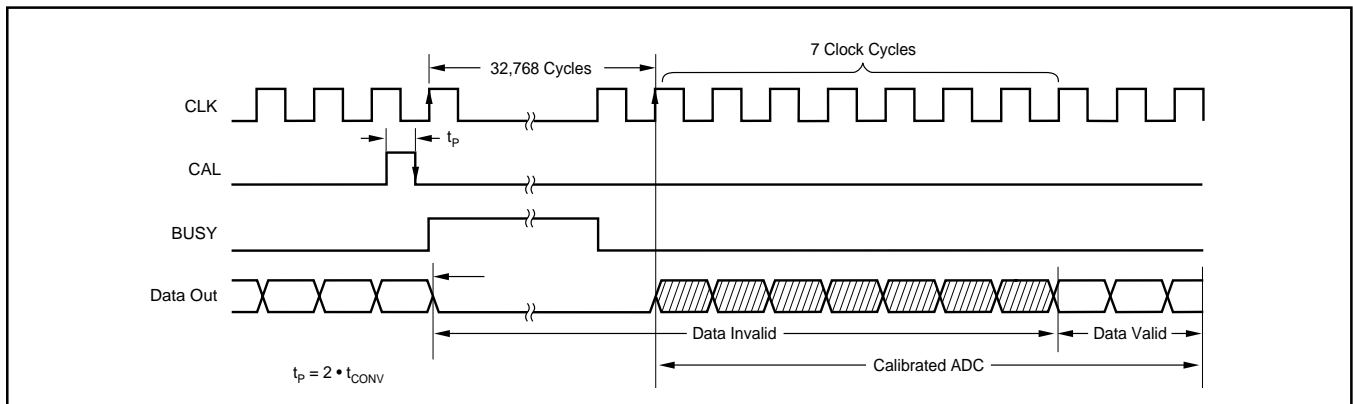

TIMING DIAGRAM 3. Calibration-On-Demand Mode Timing.

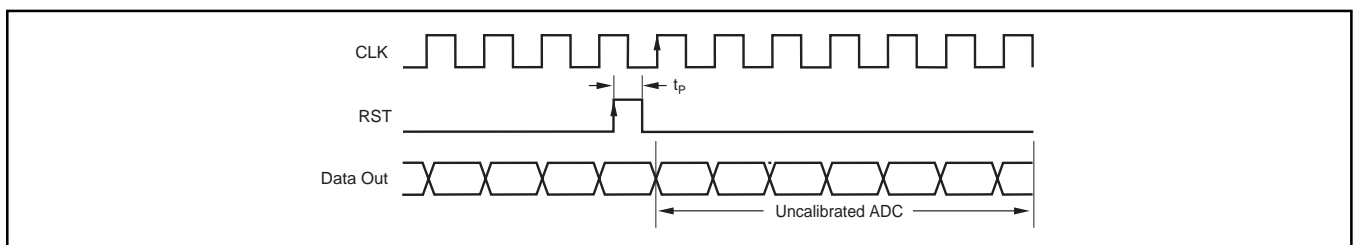

TIMING DIAGRAM 4. Reset Mode Timing.

TYPICAL CHARACTERISTICS

At T_A = full specified temperature range, $V_S = +5V$, specified input range = 1.5V to 3.5V, differential internal reference input and sampling rate = 10MSPS after calibration, $V_{REF} = 2V$, -1dB input, unless otherwise specified.

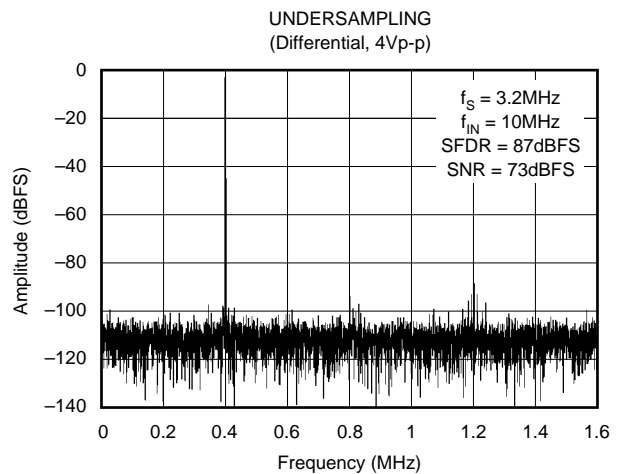
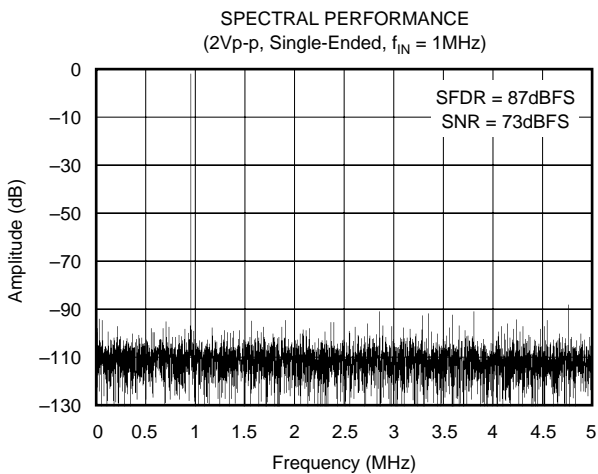
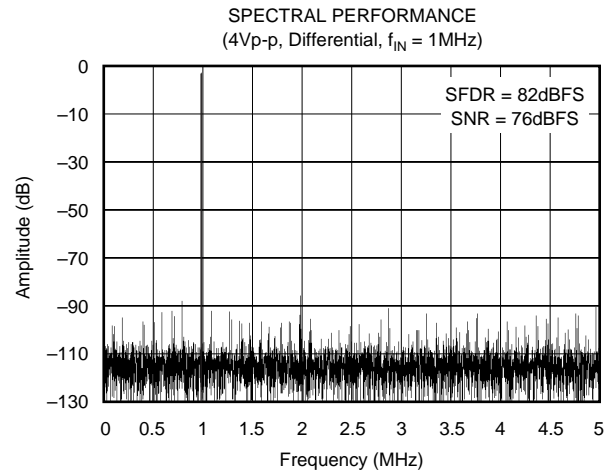
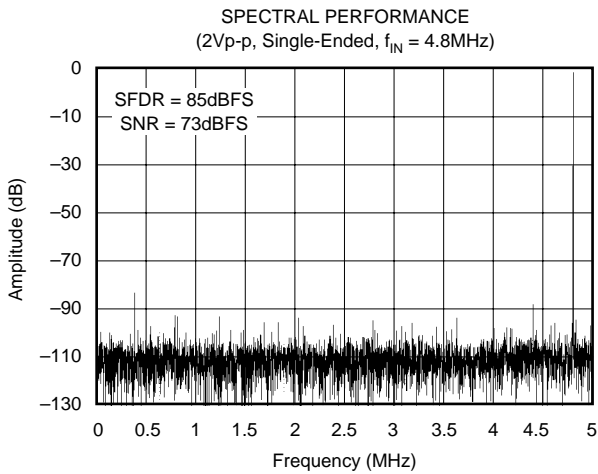
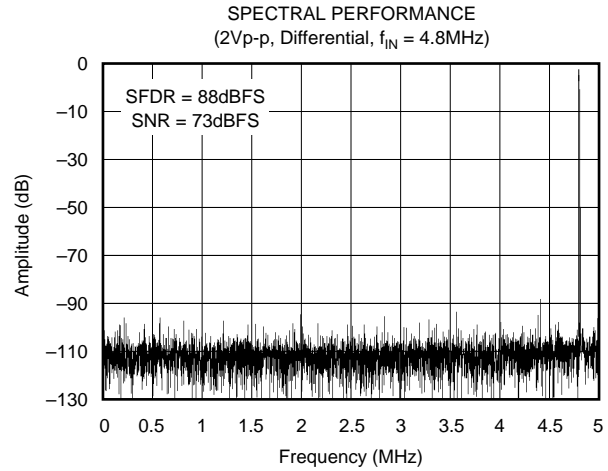
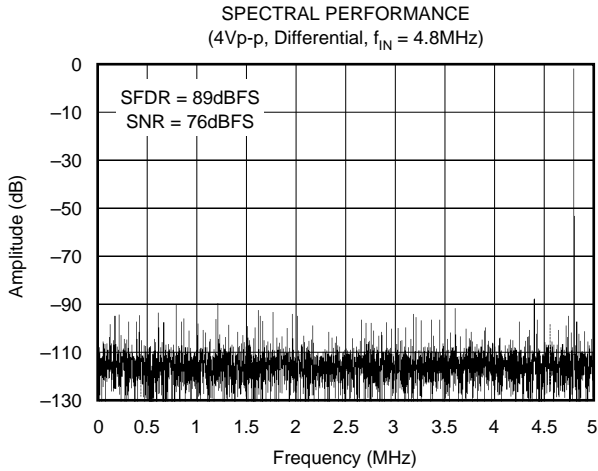

TYPICAL CHARACTERISTICS (Cont.)

At T_A = full specified temperature range, V_S = +5V, specified input range = 1.5V to 3.5V, differential internal reference input and sampling rate = 10MSPS after calibration, V_{REF} = 2V, -1dB input, unless otherwise specified.

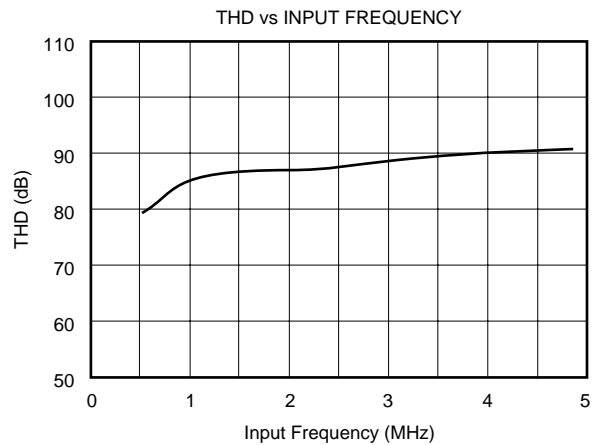
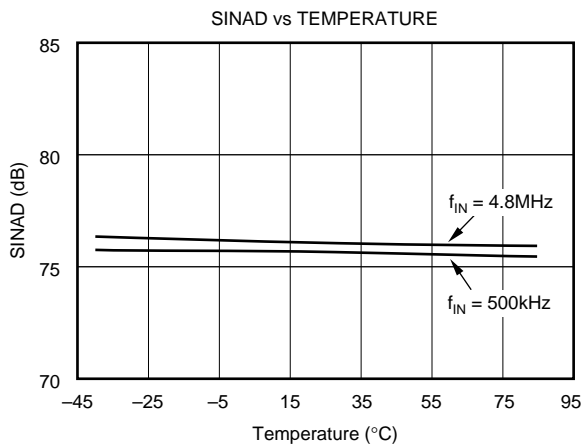
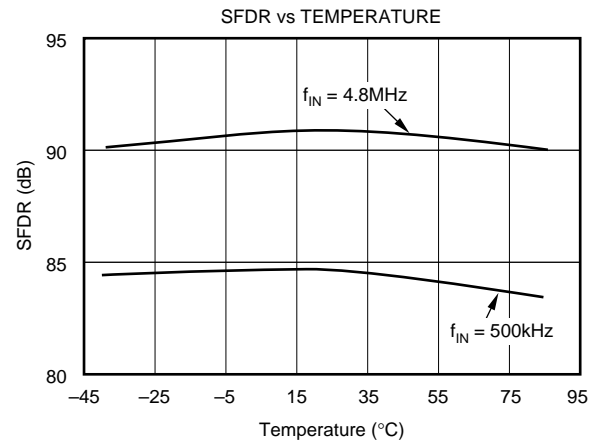
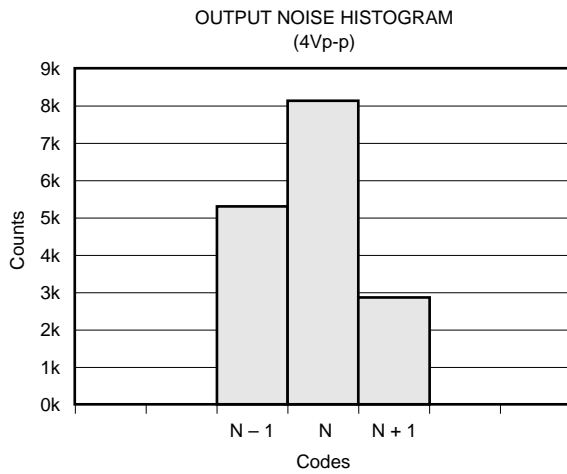
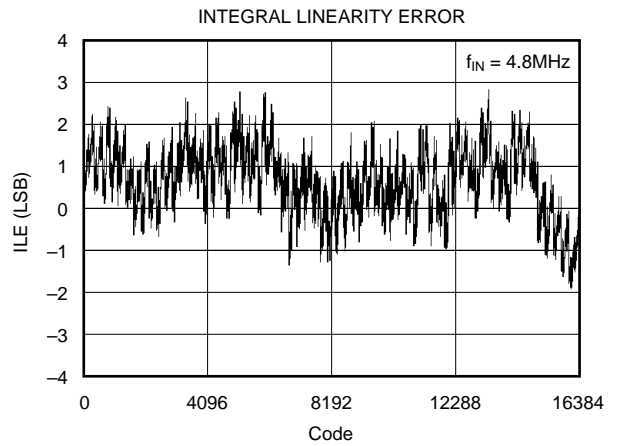
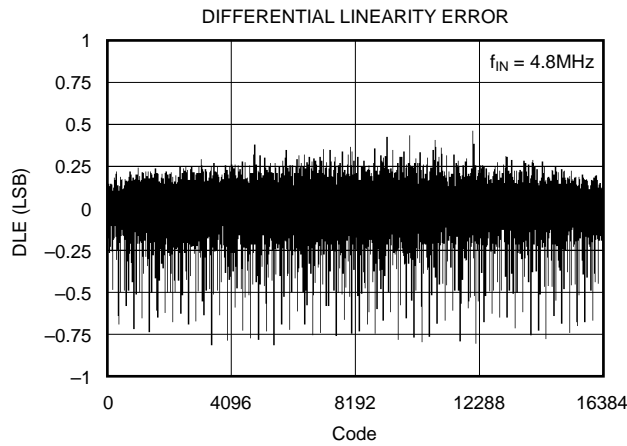

TYPICAL CHARACTERISTICS (Cont.)

At T_A = full specified temperature range, $V_S = +5V$, specified input range = 1.5V to 3.5V, differential internal reference input and sampling rate = 10MSPS after calibration, $V_{REF} = 2V$, -1dB input, unless otherwise specified.

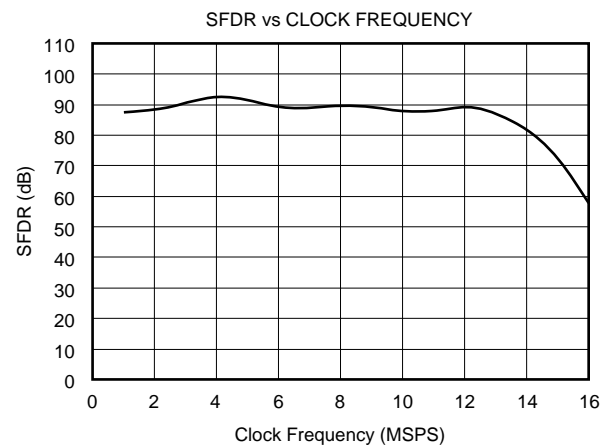
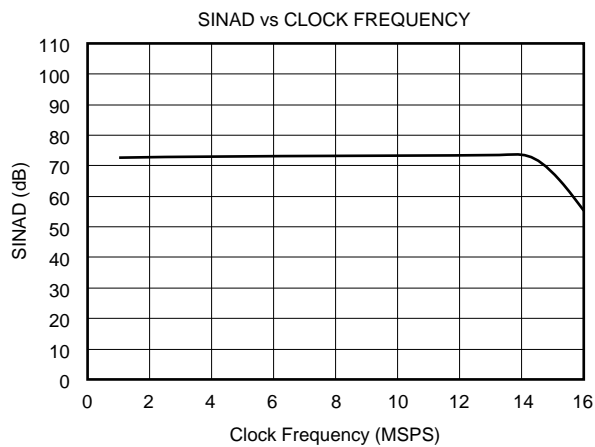
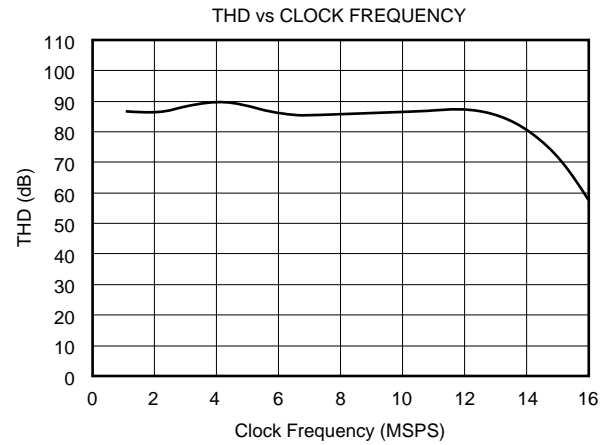
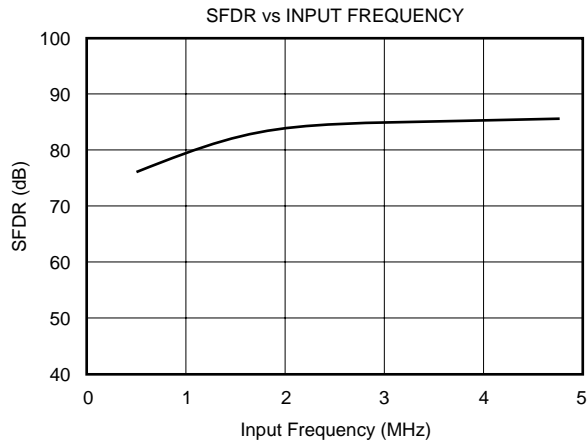
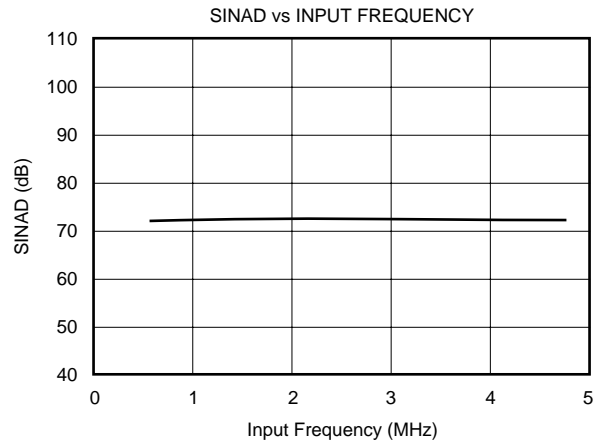
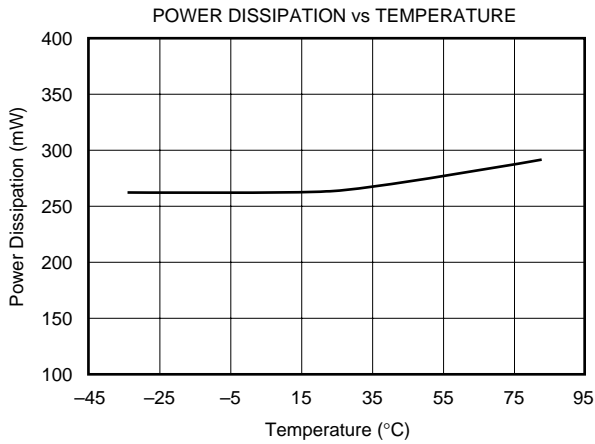

TYPICAL CHARACTERISTICS (Cont.)

At T_A = full specified temperature range, V_S = +5V, specified input range = 1.5V to 3.5V, differential internal reference input and sampling rate = 10MSPS after calibration, V_{REF} = 2V, -1dB input, unless otherwise specified.

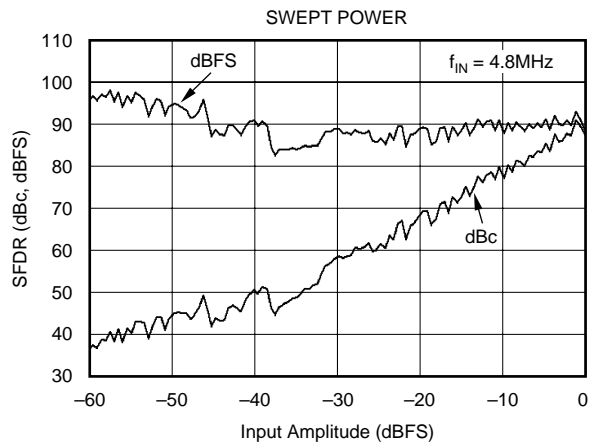

APPLICATION INFORMATION

DRIVING THE ANALOG INPUT

The ADS850 allows its analog inputs to be driven either single-ended or differentially. The focus of the following discussion is on the single-ended configuration.

CALIBRATION PROCEDURE

The calibration procedure (CAL) is started by a positive pulse, with a minimum width of 2 clock cycles. Once calibration is initiated, the clock must operate continuously and the power supplies and references must remain stable. The calibration registers are reset on the rising edge of the CAL signal. The actual calibration procedure begins at the falling edge of the CAL signal. Calibration is completed at the end of 32,775 cycles at 10MSPS, CAL = 3.28ms (see Timing Diagram 3 on page 5). During calibration, the CAL_BUSY signal stays HIGH and the digital output pins of the ADC are forced to zero. Also, during calibration, the inputs (IN and \overline{IN}) are disabled. When the calibration procedure is complete, the CAL_BUSY goes LOW. Valid data appears at the output seven cycles later or after a total of 32,775 clock cycles. If there are any changes to the clock or the temperature changes more than $\pm 20^\circ\text{C}$, the ADC should be re-calibrated to maintain performance.

At power-on (see Timing Diagram 2 on page 5), the ADC calibrates itself. The power-on delay, t_S , is the time it takes for the reference voltage to settle. Once the clock starts, the power-on delay operates for 2^{21} clock cycles. Bypass capacitors should be selected to allow the reference to settle within 200ms. If the system is noisy or external references require a longer settling time, a CAL pulse may be required.

AC-COUPLED INPUT CONFIGURATION

See Figure 1 for the circuit example of the most common interface configuration for the ADS850. With the V_{REF} pin connected to the SEL pin, the full-scale input range is defined to be 2Vp-p. This signal is ac-coupled in single-ended form to the ADS850 using the low distortion voltage-feedback amplifier OPA642. As is generally necessary for single-supply components, operating the ADS850 with a full-scale input signal swing requires a level-shift of the amplifier's zero-centered analog signal to comply with the ADC's input range requirements. Using a DC blocking capacitor between the output of the driving amplifier and the converter's input, a simple level-shifting scheme can be implemented. In this configuration, the top and bottom references (REFT, REFB) provide an output voltage of +3V and +2V, respectively. Here, two resistor pairs of $2 \cdot 2\text{k}\Omega$ are used to create a common-mode voltage of approximately +2.5V to bias the inputs of the ADS850 (IN, \overline{IN}) to the required DC voltage.

An advantage of ac-coupling is that the driving amplifier still operates with a ground-based signal swing. This will keep the distortion performance at its optimum since the signal swing stays centered within the linear region of the op amp and sufficient headroom to the supply rails can be maintained. Consider using the inverting gain configuration to eliminate CMR induced errors of the amplifier. The addition of a small series resistor (R_S) between the output of the op amp and the input of the ADS850 will be beneficial in almost all interface configurations. This will decouple the op amp's output from the capacitive load and avoid gain peaking, which can result in increased noise. For best spurious and distortion performance, the resistor value should be kept below 100Ω . Furthermore, the series resistor together with the 100pF capacitor establish a passive low-pass filter, limiting the bandwidth for the wideband noise, thus help improving the SNR performance.

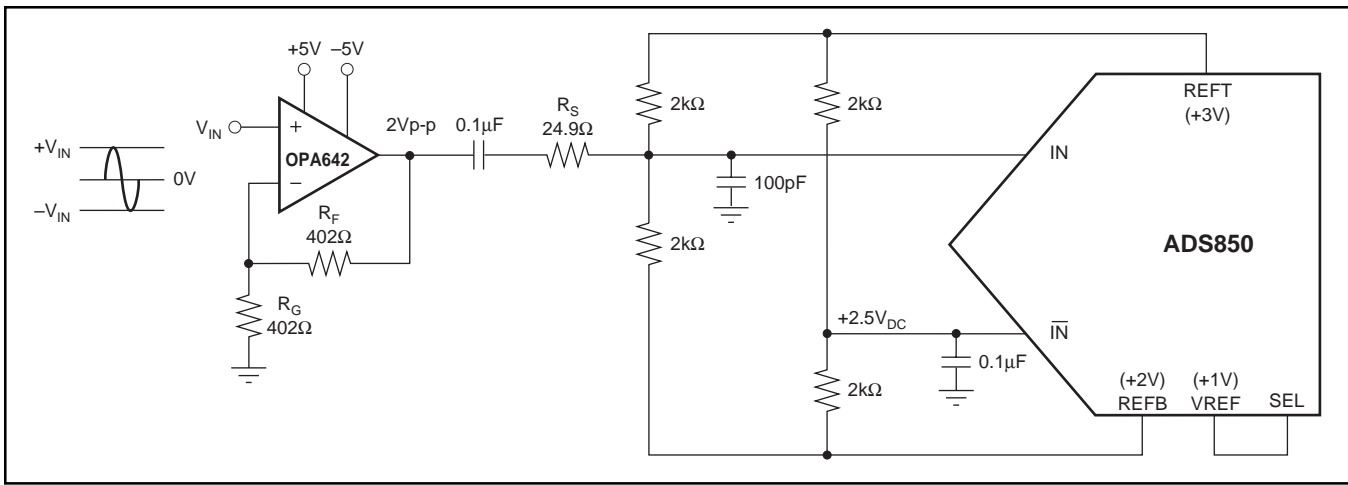

FIGURE 1. AC-Coupled Input Configuration for 2Vp-p Input Swing and Common-Mode Voltage at +2.5V Derived from Internal Top and Bottom Reference.

DC-COUPLED WITHOUT LEVEL SHIFT

In some applications the analog input signal may already be biased at a level which complies with the selected input range and reference level of the ADS850. In this case, it is only necessary to provide an adequately low source impedance to the selected input, IN or $\bar{\text{IN}}$. Always consider wideband op amps since their output impedance will stay low over a wide range of frequencies. For those applications requiring the driving amplifier to provide a signal amplification, with a gain ≥ 3 , consider using the decompensated voltage feedback op amp OPA686.

DC-COUPLED WITH LEVEL SHIFT

Several applications may require that the bandwidth of the signal path include DC, in which case the signal has to be DC-coupled to the ADC. In order to accomplish this, the interface circuit has to provide a DC-level shift. The circuit shown in Figure 2 employs an op amp, OPA681, to sum the ground

centered input signal with a required DC offset. The ADS850 typically operates with a +2.5V common-mode voltage, which is established at the center tap of the ladder and connected to the $\bar{\text{IN}}$ input of the converter. The OPA681 operates in inverting configuration. Here resistors R_1 and R_2 set the DC-bias level for the OPA681. Because of the op amp's noise gain of +2V/V, assuming $R_F = R_{\text{IN}}$, the DC offset voltage applied to its noninverting input has to be divided down to +1.25V, resulting in a DC output voltage of +2.5V. DC voltage differences between the IN and $\bar{\text{IN}}$ inputs of the ADS850 effectively will produce an offset, which can be corrected for by adjusting the values of resistors R_1 and R_2 . The bias current of the op amp may also result in an undesired offset. The selection criteria of the appropriate op amp should include the input bias current, output voltage swing, distortion and noise specification. Note that in this example the overall signal phase is inverted. To re-establish the original signal polarity, it is always possible to interchange the IN and $\bar{\text{IN}}$ connections.

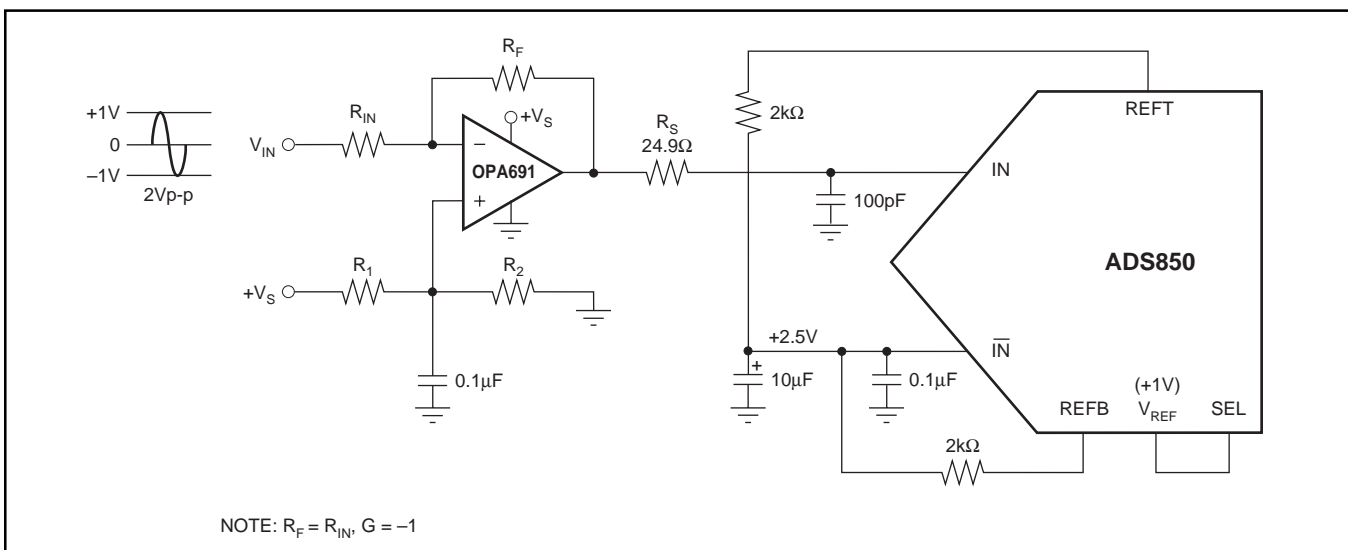

FIGURE 2. DC-Coupled, Single-Ended Input Configuration with DC-level Shift.

SINGLE-ENDED-TO-DIFFERENTIAL CONFIGURATION (TRANSFORMER COUPLED)

In order to select the best suited interface circuit for the ADS850, the performance requirements must be known. If an ac-coupled input is needed for a particular application, the next step is to determine the method of applying the signal; either single-ended or differentially. The differential input configuration may provide a noticeable advantage of achieving good SFDR performance based on the fact that in the differential mode, the signal swing can be reduced to half of the swing required for single-ended drive. Secondly, by driving the ADS850 differentially, the even-order harmonics will be reduced. Figure 3 shows the schematic for the suggested transformer-coupled interface circuit. The resistor across the secondary side (R_T) should be set to get an input impedance match (e.g., $R_T = n^2 \cdot R_G$).

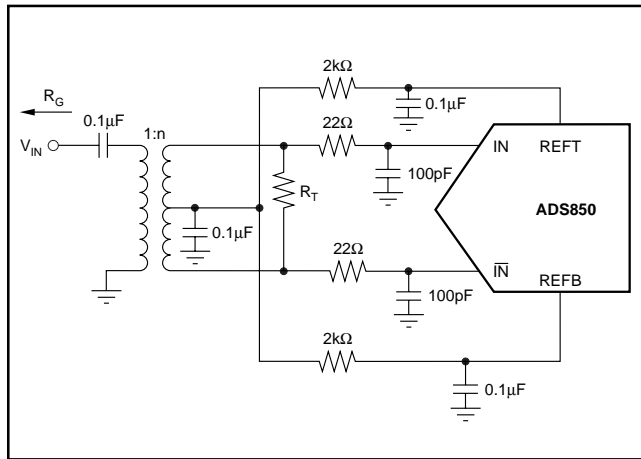

FIGURE 3. Transformer-Coupled Input.

REFERENCE OPERATION

Integrated into the ADS850 is a bandgap reference circuit including logic that provides either a +1V or +2V reference output, by simply selecting the corresponding pin-strap configuration. For more design flexibility, the internal reference can be shut off and an external reference voltage used. Table I provides an overview of the possible reference options and pin configurations.

MODE	INPUT RANGE	SEL	V_{REF}	REFB	REFT
Internal	2Vp-p	V_{REF}	SEL	NC	NC
Internal	4Vp-p	GND	NC	NC	NC
External	$2V < FSR < 4V$	$+V_S$	$1V < FSR < 2V$	NC	NC
External	$(REFB - REFT) \cdot 2$	$+V_S$	GND	$1.5V < REFB < 2V$	$2V < REFT < 3.5V$

TABLE I. Selected Reference Configuration Examples.

A simple model of the internal reference circuit is shown in Figure 4. The internal blocks are a 1V bandgap voltage reference, buffer, the resistive reference ladder, and the drivers for the top and bottom reference which supply the necessary current to the internal nodes. As shown, the output of the buffer appears at the V_{REF} pin. The full-scale input span of the ADS850 is determined by the voltage at V_{REF} , according to Equation 1:

$$\text{Full-Scale Input Span} = 2 \cdot V_{REF} \quad (1)$$

Note that the current drive capability of this amplifier is limited to about 1mA and should not be used to drive low loads. The programmable reference circuit is controlled by the voltage applied to the select pin (SEL). Refer to Table I for an overview.

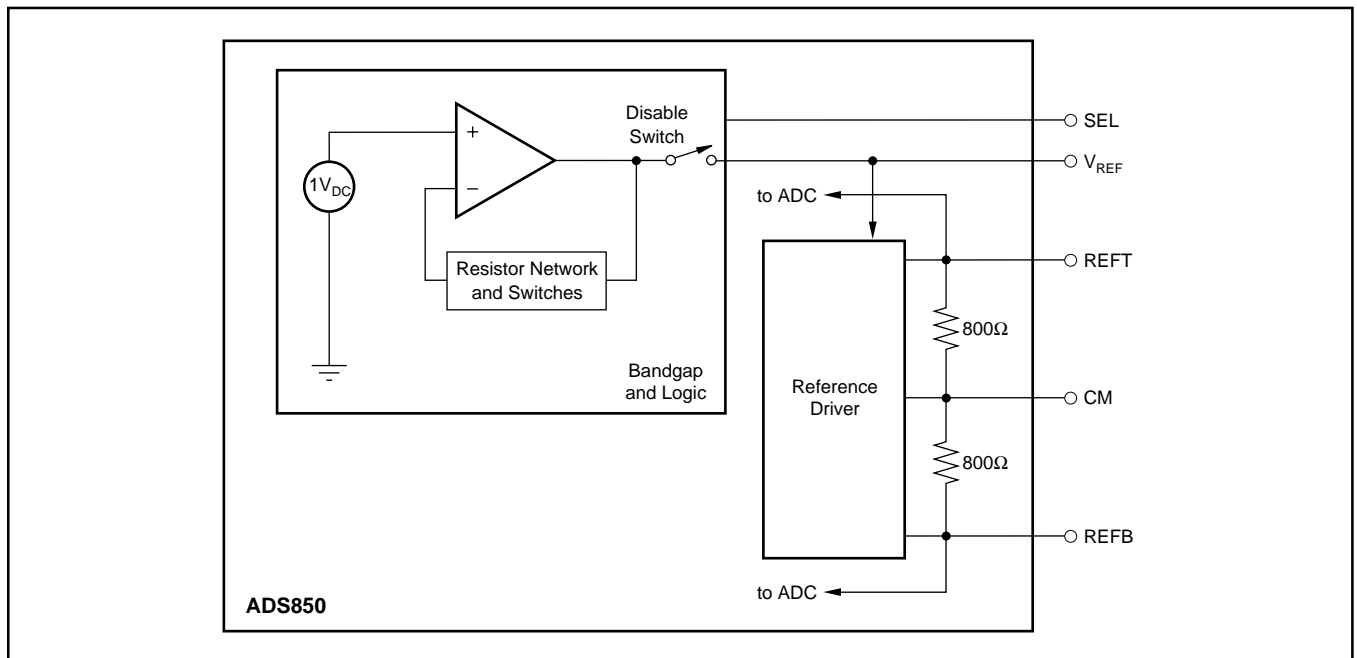

FIGURE 4. Equivalent Reference Circuit.

The top reference (REFT) and the bottom reference (REFB) are brought out mainly for external bypassing. For proper operation with all reference configurations, it is necessary to provide solid bypassing to the reference pins in order to keep the clock feedthrough to a minimum. Figure 5 shows the recommended reference decoupling configuration.

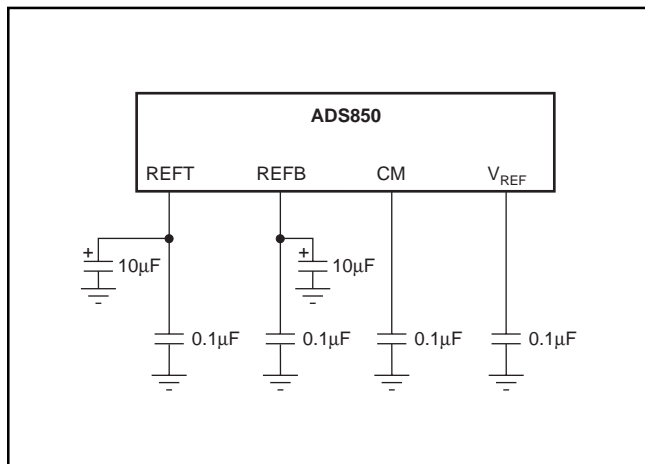

FIGURE 5. Recommended Reference Bypassing Scheme.

In addition, the Common-Mode Voltage (CMV) may be used as a reference level to provide the appropriate offset for the driving circuitry. However, care must be taken not to appreciably load this node, which is not buffered and has a high impedance. An alternate method of generating a common-mode voltage is given in Figure 6. Here, two external precision resistors (tolerance 1% or better) are located between the top and bottom reference pins. The common-mode level will appear at the midpoint. The output buffers of the top and bottom reference are designed to supply approximately 2mA of output current.

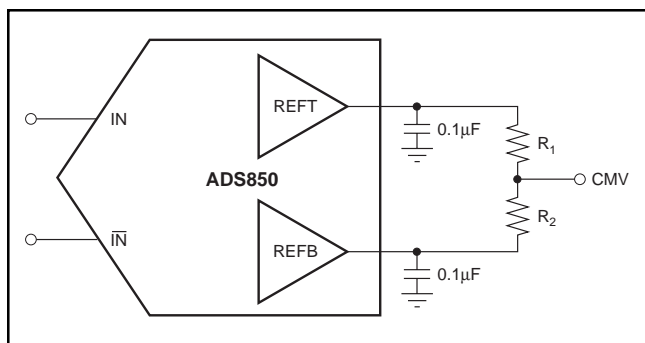

FIGURE 6. Alternative Circuit to Generate Common-Mode Voltage.

EXTERNAL REFERENCE OPERATION

Depending on the application requirements, it might be advantageous to operate the ADS850 with an external reference. This may improve the DC accuracy if the external reference circuitry is superior in its drift and accuracy. To use the ADS850 with an external reference, the user must disable the internal reference, as shown in Figure 7. By connecting the SEL pin to $+V_S$, the internal logic will shut

down the internal reference. At the same time, the output of the internal reference buffer is disconnected from the V_{REF} pin, which now must be driven with the external reference. Note that a similar bypassing scheme should be maintained as described for the internal reference operation.

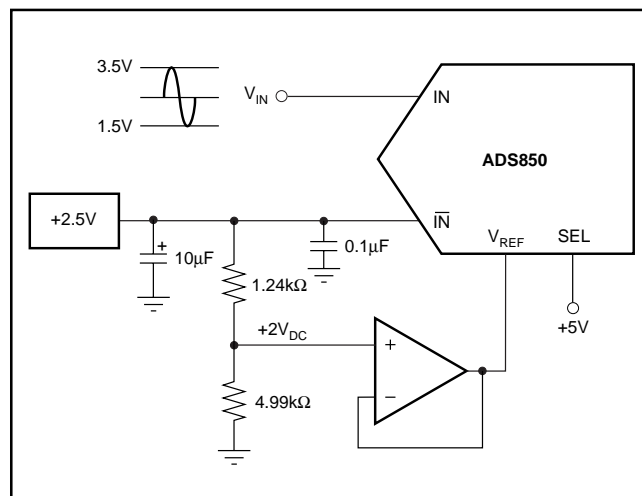

FIGURE 7. External Reference, Input Range 1.5V to 3.5V (2Vp-p), Single-Ended, with +2.5V Common-Mode Voltage.

DIGITAL INPUTS AND OUTPUTS

Over Range (OVR)

One feature of the ADS850 is its 'Over Range' digital output (OVR). This pin can be used to monitor any out-of-range condition, which occurs every time the applied analog input voltage exceeds the input range (set by V_{REF}). The OVR output is LOW when the input voltage is within the defined input range. It becomes HIGH when the input voltage is beyond the input range. This is the case when the input voltage is either below the bottom reference voltage or above the top reference voltage. OVR will remain active until the analog input returns to its normal signal range and another conversion is completed. Using the MSB and its complement in conjunction with OVR a simple clue logic can be built that detects the overrange and underrange conditions, as shown in Figure 8. It should be noted that OVR is a digital output which is updated along with the bit information corresponding to the particular sampling incidence of the analog signal. Therefore, the OVR data is subject to the same pipeline delay (latency) as the digital data.

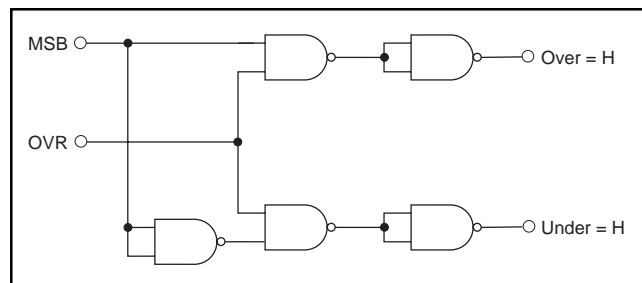

FIGURE 8. External Logic for Decoding Under- and Over-Range Condition.

CLOCK INPUT REQUIREMENTS

Clock jitter is critical to the SNR performance of high-speed, high-resolution ADCs. It leads to aperture jitter (t_A) which adds noise to the signal being converted. The ADS850 samples the input signal on the rising edge of the CLK input. Therefore, this edge should have the lowest possible jitter. The jitter noise contribution to total SNR is given by the following equation. If this value is near your system requirements, input clock jitter must be reduced.

$$\text{JitterSNR} = 20 \log \frac{1}{2\pi f_{IN} t_A} \text{rms signal to rms noise}$$

Where: f_{IN} is Input Signal Frequency

t_A is rms Clock Jitter

Particularly in undersampling applications, special consideration should be given to clock jitter. The clock input should be treated as an analog input in order to achieve the highest level of performance. Any overshoot or undershoot of the clock signal may cause degradation of the performance. When digitizing at high sampling rates, the clock should have a 50% duty cycle ($t_H = t_L$), along with fast rise and fall times of 2ns or less.

DIGITAL OUTPUTS

The digital outputs of the ADS850 are designed to be compatible with both high speed TTL and CMOS logic families. The driver stage for the digital outputs is supplied through a separate supply pin, VDRV, which is not connected to the analog supply pins. By adjusting the voltage on VDRV, the digital output levels will vary respectively. Therefore, it is possible to operate the ADS850 on a +5V analog supply while interfacing the digital outputs to 3V logic.

It is recommended to keep the capacitive loading on the data lines as low as possible ($\leq 15\text{pF}$). Larger capacitive loads demand higher charging currents as the outputs are changing. Those high current surges can feed back to the analog portion of the ADS850 and influence the performance. If necessary, external buffers or latches may be used which provide the added benefit of isolating the ADS850 from any digital noise activities on the bus coupling back high frequency noise. In addition, resistors in series with each data line may help maintain the ac performance of the ADS850. Their use depends on the capacitive loading seen by the converter. Values in the range of 100Ω to 200Ω will limit the instantaneous current the output stage has to provide for recharging the parasitic capacitances, as the output levels change from LOW to HIGH or HIGH to LOW.

GROUNDING AND DECOUPLING

Proper grounding and bypassing, short lead length, and the use of ground planes are particularly important for high frequency designs. Multi-layer PC boards are recommended for best performance since they offer distinct advantages like minimizing ground impedance, separation of signal layers by ground layers, etc. It is recommended that the analog and digital ground pins of the ADS850 be joined together at the IC and be connected only to the analog ground of the system.

The ADS850 has analog and digital supply pins, however, the converter should be treated as an analog component and all supply pins should be powered by the analog supply. This will ensure the most consistent results, since digital supply lines often carry high levels of noise that would otherwise be coupled into the converter and degrade the achievable performance.

Because of the pipeline architecture, the converter also generates high frequency current transients and noise that are fed back into the supply and reference lines. This requires that the supply and reference pins be sufficiently bypassed. Figure 9 shows the recommended decoupling scheme for the analog supplies. In most cases, $0.1\mu\text{F}$ ceramic chip capacitors are adequate to keep the impedance low over a wide frequency range. Their effectiveness largely depends on the proximity to the individual supply pin. Therefore, they should be located as close to the supply pins as possible. In addition, a larger size bipolar capacitor ($1\mu\text{F}$ to $22\mu\text{F}$) should be placed on the PC board in close proximity to the converter circuit.

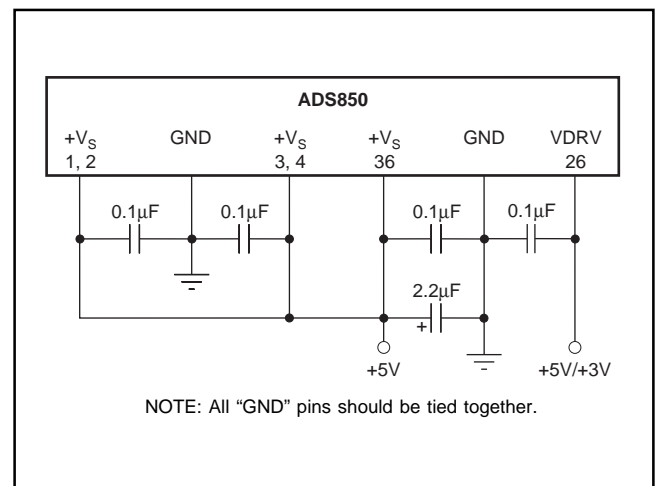

FIGURE 9. Recommended Bypassing for Analog Supply Pins.

PACKAGING INFORMATION

Orderable Device	Status (1)	Package Type	Package Drawing	Pins	Package Qty	Eco Plan (2)	Lead/Ball Finish (6)	MSL Peak Temp (3)	Op Temp (°C)	Device Marking (4/5)	Samples
ADS850Y/250	ACTIVE	TQFP	PFB	48	250	Green (RoHS & no Sb/Br)	CU NIPDAU	Level-2-260C-1 YEAR	-40 to 85	ADS850Y	Samples
ADS850Y/2K	ACTIVE	TQFP	PFB	48	2000	Green (RoHS & no Sb/Br)	CU NIPDAU	Level-2-260C-1 YEAR	-40 to 85	ADS850Y	Samples

(1) The marketing status values are defined as follows:

ACTIVE: Product device recommended for new designs.

LIFEBUY: TI has announced that the device will be discontinued, and a lifetime-buy period is in effect.

NRND: Not recommended for new designs. Device is in production to support existing customers, but TI does not recommend using this part in a new design.

PREVIEW: Device has been announced but is not in production. Samples may or may not be available.

OBsolete: TI has discontinued the production of the device.

(2) Eco Plan - The planned eco-friendly classification: Pb-Free (RoHS), Pb-Free (RoHS Exempt), or Green (RoHS & no Sb/Br) - please check <http://www.ti.com/productcontent> for the latest availability information and additional product content details.

TBD: The Pb-Free/Green conversion plan has not been defined.

Pb-Free (RoHS): TI's terms "Lead-Free" or "Pb-Free" mean semiconductor products that are compatible with the current RoHS requirements for all 6 substances, including the requirement that lead not exceed 0.1% by weight in homogeneous materials. Where designed to be soldered at high temperatures, TI Pb-Free products are suitable for use in specified lead-free processes.

Pb-Free (RoHS Exempt): This component has a RoHS exemption for either 1) lead-based flip-chip solder bumps used between the die and package, or 2) lead-based die adhesive used between the die and leadframe. The component is otherwise considered Pb-Free (RoHS compatible) as defined above.

Green (RoHS & no Sb/Br): TI defines "Green" to mean Pb-Free (RoHS compatible), and free of Bromine (Br) and Antimony (Sb) based flame retardants (Br or Sb do not exceed 0.1% by weight in homogeneous material)

(3) MSL, Peak Temp. - The Moisture Sensitivity Level rating according to the JEDEC industry standard classifications, and peak solder temperature.

(4) There may be additional marking, which relates to the logo, the lot trace code information, or the environmental category on the device.

(5) Multiple Device Markings will be inside parentheses. Only one Device Marking contained in parentheses and separated by a "~" will appear on a device. If a line is indented then it is a continuation of the previous line and the two combined represent the entire Device Marking for that device.

(6) Lead/Ball Finish - Orderable Devices may have multiple material finish options. Finish options are separated by a vertical ruled line. Lead/Ball Finish values may wrap to two lines if the finish value exceeds the maximum column width.

Important Information and Disclaimer: The information provided on this page represents TI's knowledge and belief as of the date that it is provided. TI bases its knowledge and belief on information provided by third parties, and makes no representation or warranty as to the accuracy of such information. Efforts are underway to better integrate information from third parties. TI has taken and continues to take reasonable steps to provide representative and accurate information but may not have conducted destructive testing or chemical analysis on incoming materials and chemicals. TI and TI suppliers consider certain information to be proprietary, and thus CAS numbers and other limited information may not be available for release.

In no event shall TI's liability arising out of such information exceed the total purchase price of the TI part(s) at issue in this document sold by TI to Customer on an annual basis.

TAPE AND REEL INFORMATION



QUADRANT ASSIGNMENTS FOR PIN 1 ORIENTATION IN TAPE



*All dimensions are nominal

Device	Package Type	Package Drawing	Pins	SPQ	Reel Diameter (mm)	Reel Width W1 (mm)	A0 (mm)	B0 (mm)	K0 (mm)	P1 (mm)	W (mm)	Pin1 Quadrant
ADS850Y/250	TQFP	PFB	48	250	180.0	17.0	9.6	9.6	1.5	12.0	16.0	Q2

TAPE AND REEL BOX DIMENSIONS

*All dimensions are nominal

Device	Package Type	Package Drawing	Pins	SPQ	Length (mm)	Width (mm)	Height (mm)
ADS850Y/250	TQFP	PFB	48	250	210.0	185.0	35.0

IMPORTANT NOTICE

Texas Instruments Incorporated (TI) reserves the right to make corrections, enhancements, improvements and other changes to its semiconductor products and services per JESD46, latest issue, and to discontinue any product or service per JESD48, latest issue. Buyers should obtain the latest relevant information before placing orders and should verify that such information is current and complete.

TI's published terms of sale for semiconductor products (<http://www.ti.com/sc/docs/stdterms.htm>) apply to the sale of packaged integrated circuit products that TI has qualified and released to market. Additional terms may apply to the use or sale of other types of TI products and services.

Reproduction of significant portions of TI information in TI data sheets is permissible only if reproduction is without alteration and is accompanied by all associated warranties, conditions, limitations, and notices. TI is not responsible or liable for such reproduced documentation. Information of third parties may be subject to additional restrictions. Resale of TI products or services with statements different from or beyond the parameters stated by TI for that product or service voids all express and any implied warranties for the associated TI product or service and is an unfair and deceptive business practice. TI is not responsible or liable for any such statements.

Buyers and others who are developing systems that incorporate TI products (collectively, "Designers") understand and agree that Designers remain responsible for using their independent analysis, evaluation and judgment in designing their applications and that Designers have full and exclusive responsibility to assure the safety of Designers' applications and compliance of their applications (and of all TI products used in or for Designers' applications) with all applicable regulations, laws and other applicable requirements. Designer represents that, with respect to their applications, Designer has all the necessary expertise to create and implement safeguards that (1) anticipate dangerous consequences of failures, (2) monitor failures and their consequences, and (3) lessen the likelihood of failures that might cause harm and take appropriate actions. Designer agrees that prior to using or distributing any applications that include TI products, Designer will thoroughly test such applications and the functionality of such TI products as used in such applications.

TI's provision of technical, application or other design advice, quality characterization, reliability data or other services or information, including, but not limited to, reference designs and materials relating to evaluation modules, (collectively, "TI Resources") are intended to assist designers who are developing applications that incorporate TI products; by downloading, accessing or using TI Resources in any way, Designer (individually or, if Designer is acting on behalf of a company, Designer's company) agrees to use any particular TI Resource solely for this purpose and subject to the terms of this Notice.

TI's provision of TI Resources does not expand or otherwise alter TI's applicable published warranties or warranty disclaimers for TI products, and no additional obligations or liabilities arise from TI providing such TI Resources. TI reserves the right to make corrections, enhancements, improvements and other changes to its TI Resources. TI has not conducted any testing other than that specifically described in the published documentation for a particular TI Resource.

Designer is authorized to use, copy and modify any individual TI Resource only in connection with the development of applications that include the TI product(s) identified in such TI Resource. NO OTHER LICENSE, EXPRESS OR IMPLIED, BY ESTOPPEL OR OTHERWISE TO ANY OTHER TI INTELLECTUAL PROPERTY RIGHT, AND NO LICENSE TO ANY TECHNOLOGY OR INTELLECTUAL PROPERTY RIGHT OF TI OR ANY THIRD PARTY IS GRANTED HEREIN, including but not limited to any patent right, copyright, mask work right, or other intellectual property right relating to any combination, machine, or process in which TI products or services are used. Information regarding or referencing third-party products or services does not constitute a license to use such products or services, or a warranty or endorsement thereof. Use of TI Resources may require a license from a third party under the patents or other intellectual property of the third party, or a license from TI under the patents or other intellectual property of TI.

TI RESOURCES ARE PROVIDED "AS IS" AND WITH ALL FAULTS. TI DISCLAIMS ALL OTHER WARRANTIES OR REPRESENTATIONS, EXPRESS OR IMPLIED, REGARDING RESOURCES OR USE THEREOF, INCLUDING BUT NOT LIMITED TO ACCURACY OR COMPLETENESS, TITLE, ANY EPIDEMIC FAILURE WARRANTY AND ANY IMPLIED WARRANTIES OF MERCHANTABILITY, FITNESS FOR A PARTICULAR PURPOSE, AND NON-INFRINGEMENT OF ANY THIRD PARTY INTELLECTUAL PROPERTY RIGHTS. TI SHALL NOT BE LIABLE FOR AND SHALL NOT DEFEND OR INDEMNIFY DESIGNER AGAINST ANY CLAIM, INCLUDING BUT NOT LIMITED TO ANY INFRINGEMENT CLAIM THAT RELATES TO OR IS BASED ON ANY COMBINATION OF PRODUCTS EVEN IF DESCRIBED IN TI RESOURCES OR OTHERWISE. IN NO EVENT SHALL TI BE LIABLE FOR ANY ACTUAL, DIRECT, SPECIAL, COLLATERAL, INDIRECT, PUNITIVE, INCIDENTAL, CONSEQUENTIAL OR EXEMPLARY DAMAGES IN CONNECTION WITH OR ARISING OUT OF TI RESOURCES OR USE THEREOF, AND REGARDLESS OF WHETHER TI HAS BEEN ADVISED OF THE POSSIBILITY OF SUCH DAMAGES.

Unless TI has explicitly designated an individual product as meeting the requirements of a particular industry standard (e.g., ISO/TS 16949 and ISO 26262), TI is not responsible for any failure to meet such industry standard requirements.

Where TI specifically promotes products as facilitating functional safety or as compliant with industry functional safety standards, such products are intended to help enable customers to design and create their own applications that meet applicable functional safety standards and requirements. Using products in an application does not by itself establish any safety features in the application. Designers must ensure compliance with safety-related requirements and standards applicable to their applications. Designer may not use any TI products in life-critical medical equipment unless authorized officers of the parties have executed a special contract specifically governing such use. Life-critical medical equipment is medical equipment where failure of such equipment would cause serious bodily injury or death (e.g., life support, pacemakers, defibrillators, heart pumps, neurostimulators, and implantables). Such equipment includes, without limitation, all medical devices identified by the U.S. Food and Drug Administration as Class III devices and equivalent classifications outside the U.S.

TI may expressly designate certain products as completing a particular qualification (e.g., Q100, Military Grade, or Enhanced Product). Designers agree that it has the necessary expertise to select the product with the appropriate qualification designation for their applications and that proper product selection is at Designers' own risk. Designers are solely responsible for compliance with all legal and regulatory requirements in connection with such selection.

Designer will fully indemnify TI and its representatives against any damages, costs, losses, and/or liabilities arising out of Designer's non-compliance with the terms and provisions of this Notice.

Looking for pricing, stock, or lifecycle information?

Click below to explore more details on WIN SOURCE:

 [View ADS850Y/250](#) on WIN SOURCE

 [Texas Instruments](#) Information

Optimize Your Supply Chain with WIN SOURCE Solutions

-  Global Sourcing Solution
-  Obsolete Management
-  Cost Control Management
-  Shortage Management
-  Alternative Solution
-  Excess Inventory Management