



**THE DATASHEET OF
SG2013J**



The SN5405 is obsolete and no longer is supplied.

SN54LS05, SN54S05 SN7405, SN74LS05, SN74S05 HEX INVERTERS WITH OPEN-COLLECTOR OUTPUTS

SDLS030A – DECEMBER 1983 – REVISED NOVEMBER 2003

- Package Options Include Plastic Small-Outline (D, NS), Shrink Small-Outline (DB), and Ceramic Flat (W) Packages, Ceramic Chip Carriers (FK), and Standard Plastic (N) and Ceramic (J) DIPs

- Dependable Texas Instrument Quality and Reliability

SN5405, SN54LS05, SN54S05 . . . J PACKAGE

SN7405 . . . N PACKAGE

SN74LS05 . . . D, DB, N, OR NS PACKAGE

SN74S05 . . . D, N, OR NS PACKAGE

(TOP VIEW)

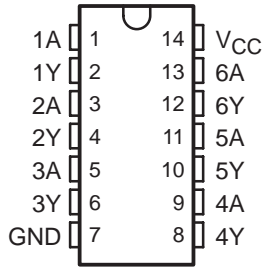

SN54LS05, SN54S05 . . . W PACKAGE

(TOP VIEW)

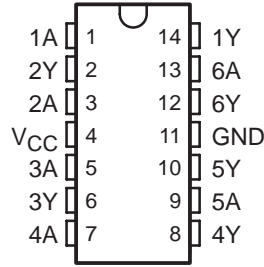

SN54LS05, SN54S05 . . . FK PACKAGE
(TOP VIEW)

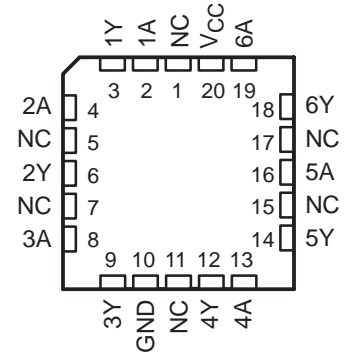

NC – No internal connection

description/ordering information

These devices contain six independent inverters. To perform correctly, the open-collector outputs require pullup resistors. These devices may be connected to other open-collector outputs to implement active-low wired-OR or active-high wire-AND functions. Open-collector devices often are used to generate high V_{OH} levels.

ORDERING INFORMATION

T _A	PACKAGE†		ORDERABLE PART NUMBER	TOP-SIDE MARKING	
0°C to 70°C	PDIP – N	Tube	SN7405N	SN7405N	
			SN74LS05N	SN74LS05N	
			SN74S05N	SN74S05N	
	SOIC – D	Tube	SN74LS05D	LS05	
			SN74LS05DR		
			Tape and reel	SN74S05D	S05
				SN74S05DR	
SOP – NS	Tape and reel	SN74LS05NSR	74LS05		
		SN74S05NSR	74S05		
	SSOP – DB	Tape and reel	SN74LS05DBR	LS05	
–55°C to 125°C	CDIP – J	Tube	SNJ54LS05J	SNJ54LS05J	
			SNJ54S05J	SNJ54S05J	
	CDIP – W	Tube	SNJ54LS05W	SNJ54LS05W	
			SNJ54S05W	SNJ54S05W	
	LCCC – FK	Tube	SNJ54LS05FK	SNJ54LS05FK	
		SNJ54S05FK	SNJ54S05FK		

† Package drawings, standard packing quantities, thermal data, symbolization, and PCB design guidelines are available at www.ti.com/sc/package.



Please be aware that an important notice concerning availability, standard warranty, and use in critical applications of Texas Instruments semiconductor products and disclaimers thereto appears at the end of this data sheet.

PRODUCTION DATA information is current as of publication date. Products conform to specifications per the terms of Texas Instruments standard warranty. Production processing does not necessarily include testing of all parameters.

TEXAS
INSTRUMENTS

POST OFFICE BOX 655303 • DALLAS, TEXAS 75265

Copyright © 2003, Texas Instruments Incorporated
On products compliant to MIL-PRF-38535, all parameters are tested unless otherwise noted. On all other products, production processing does not necessarily include testing of all parameters.

SN54LS05, SN54S05
SN7405, SN74LS05, SN74S05
HEX INVERTERS WITH OPEN-COLLECTOR OUTPUTS

SDLS030A – DECEMBER 1983 – REVISED NOVEMBER 2003

The SN5405 is obsolete
and no longer is supplied.

FUNCTION TABLE
(each inverter)

INPUT A	OUTPUT Y
H	L
L	H

logic diagram (positive logic)

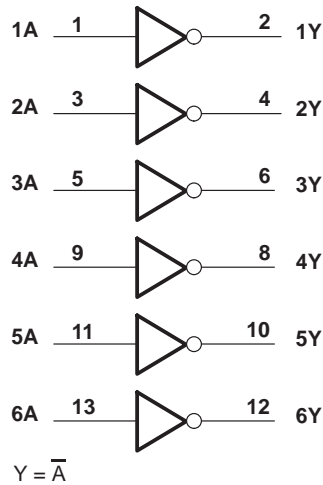

Pin numbers shown are for the D, DB, J, N, and NS packages.

The SN5405 is obsolete
and no longer is supplied.

SN54LS05, SN54S05 SN7405, SN74LS05, SN74S05 HEX INVERTERS WITH OPEN-COLLECTOR OUTPUTS

SDLS030A – DECEMBER 1983 – REVISED NOVEMBER 2003

schematic (each inverter)

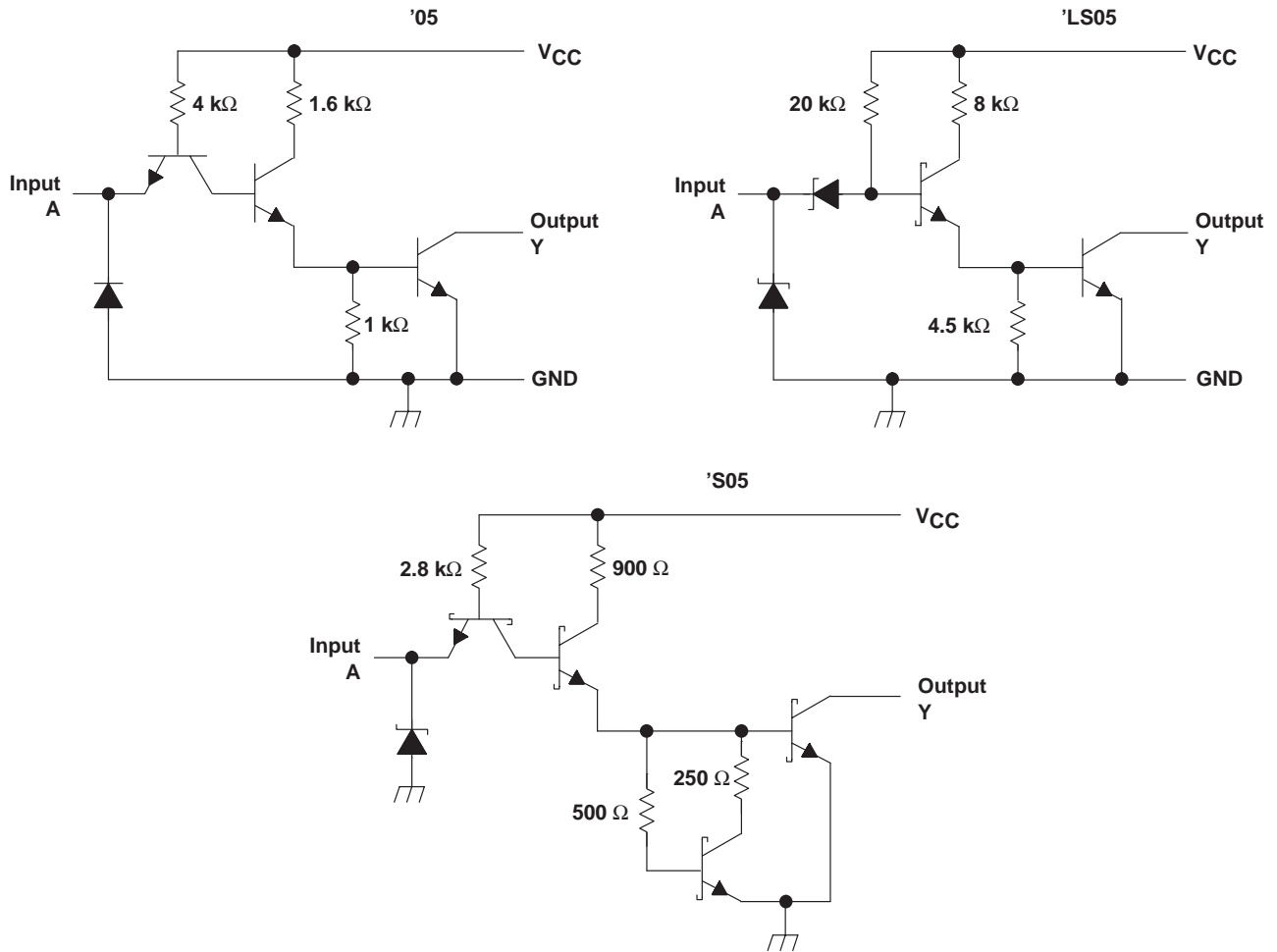

Resistor values shown are nominal.

absolute maximum ratings over operating free-air temperature (unless otherwise noted)[†]

Supply voltage, V _{CC} (see Note 1): '05, 'LS05, 'S05	7 V
Input voltage, V _I : '05, 'S05	5.5 V
'LS05	7 V
Off-state output voltage, V _O	7 V
Package thermal impedance, θ _{JA} (see Note 2): D package	86°C/W
DB package	96°C/W
N package	80°C/W
NS package	76°C/W
Storage temperature range, T _{stg}	–65°C to 150°C

[†] Stresses beyond those listed under "absolute maximum ratings" may cause permanent damage to the device. These are stress ratings only, and functional operation of the device at these or any other conditions beyond those indicated under "recommended operating conditions" is not implied. Exposure to absolute-maximum-rated conditions for extended periods may affect device reliability.

- NOTES: 1. Voltage values are with respect to network ground terminal.
2. The package thermal impedance is calculated in accordance with JESD 51-7.

**SN54LS05, SN54S05
SN7405, SN74LS05, SN74S05
HEX INVERTERS WITH OPEN-COLLECTOR OUTPUTS**

SDLS030A – DECEMBER 1983 – REVISED NOVEMBER 2003

The SN5405 is obsolete
and no longer is supplied.

recommended operating conditions

	SN5405			SN7405			UNIT
	MIN	NOM	MAX	MIN	NOM	MAX	
V _{CC} Supply voltage	4.5	5	5.5	4.75	5	5.25	V
V _{IH} High-level input voltage	2			2			V
V _{IL} Low-level input voltage			0.8			0.8	V
V _{OH} High-level output voltage			5.5			5.5	V
I _{OL} Low-level output current			16			16	mA
T _A Operating free-air temperature	-55		125	0		70	°C

electrical characteristics over recommended operating free-air temperature range (unless otherwise noted)

PARAMETER	TEST CONDITIONS†	SN5405			SN7405			UNIT
		MIN	TYP‡	MAX	MIN	TYP‡	MAX	
V _{IK}	V _{CC} = MIN, I _I = -12 mA			-1.5			-1.5	V
I _{OH}	V _{CC} = MIN, V _{OH} = 5.5 V V _{IL} = 0.8 V V _{IL} = 0.7 V						0.25	mA
V _{OL}	V _{CC} = MIN, V _{IH} = 2 V, I _{OL} = 16 mA		0.2	0.4		0.2	0.4	V
I _I	V _{CC} = MAX, V _I = 5.5 V			1			1	mA
I _{IH}	V _{CC} = MAX, V _I = 2.4 V			40			40	μA
I _{IL}	V _{CC} = MAX, V _I = 0.4 V			-1.6			-1.6	mA
I _{CCH}	V _{CC} = MAX, V _I = 0 V		6	12		6	12	mA
I _{CCL}	V _{CC} = MAX, V _I = 4.5 V		18	33		18	33	mA

† For conditions shown as MIN or MAX, use the appropriate value specified under recommended operating conditions.

‡ All typical values are at V_{CC} = 5 V, T_A = 25°C.

switching characteristics, V_{CC} = 5 V, T_A = 25°C (see Figure 1)

PARAMETER	FROM (INPUT)	TO (OUTPUT)	TEST CONDITIONS		MIN	TYP	MAX	UNIT
t _{PLH}	A	Y	R _L = 4 kΩ	C _L = 15 pF		40	55	ns
t _{PHL}			R _L = 400 Ω			8	15	



The SN5405 is obsolete
and no longer is supplied.

SN54LS05, SN54S05
SN7405, SN74LS05, SN74S05
HEX INVERTERS WITH OPEN-COLLECTOR OUTPUTS

SDLS030A – DECEMBER 1983 – REVISED NOVEMBER 2003

recommended operating conditions

		SN54LS05			SN74LS05			UNIT
		MIN	NOM	MAX	MIN	NOM	MAX	
V _{CC}	Supply voltage	4.5	5	5.5	4.75	5	5.25	V
V _{IH}	High-level input voltage	2			2			V
V _{IL}	Low-level input voltage				0.7			V
V _{OH}	High-level output voltage				5.5			V
I _{OL}	Low-level output current				4			mA
T _A	Operating free-air temperature	-55			125			°C

electrical characteristics over recommended operating free-air temperature range (unless otherwise noted)

PARAMETER	TEST CONDITIONS†	SN54LS05			SN74LS05			UNIT	
		MIN	TYP‡	MAX	MIN	TYP‡	MAX		
V _{IK}	V _{CC} = MIN, I _I = -18 mA				-1.5			V	
I _{OH}	V _{CC} = MIN, V _{IL} = MAX, V _{OH} = 5.5 V				0.1			mA	
V _{OL}	V _{CC} = MIN, V _{IH} = 2 V				0.25	0.4	0.25	0.4	V
					0.35			0.5	
I _I	V _{CC} = MAX, V _I = 7 V				0.1			mA	
I _{IH}	V _{CC} = MAX, V _I = 2.7 V				20			μA	
I _{IL}	V _{CC} = MAX, V _I = 0.4 V				-0.4			mA	
I _{CCH}	V _{CC} = MAX, V _I = 0 V				1.2	2.4	1.2	2.4	mA
I _{CCL}	V _{CC} = MAX, V _I = 4.5 V				3.6	6.6	3.6	6.6	mA

† For conditions shown as MIN or MAX, use the appropriate value specified under recommended operating conditions.

‡ All typical values are at V_{CC} = 5 V, T_A = 25°C.

switching characteristics, V_{CC} = 5 V, T_A = 25°C (see Figure 2)

PARAMETER	FROM (INPUT)	TO (OUTPUT)	TEST CONDITIONS	MIN	TYP	MAX	UNIT
t _{PLH}	A	Y	R _L = 2 kΩ, C _L = 15 pF			32	ns
t _{PHL}				15	28		



**SN54LS05, SN54S05
SN7405, SN74LS05, SN74S05
HEX INVERTERS WITH OPEN-COLLECTOR OUTPUTS**

SDLS030A – DECEMBER 1983 – REVISED NOVEMBER 2003

The SN5405 is obsolete
and no longer is supplied.

recommended operating conditions

	SN54S05			SN74S05			UNIT
	MIN	NOM	MAX	MIN	NOM	MAX	
V _{CC} Supply voltage	4.5	5	5.5	4.75	5	5.25	V
V _{IH} High-level input voltage	2			2			V
V _{IL} Low-level input voltage			0.8			0.8	V
V _{OH} High-level output voltage			5.5			5.5	V
I _{OL} Low-level output current			20			20	mA
T _A Operating free-air temperature	-55		125	0		70	°C

electrical characteristics over recommended operating free-air temperature range (unless otherwise noted)

PARAMETER	TEST CONDITIONS†		SN54S05			SN74S05			UNIT
			MIN	TYP‡	MAX	MIN	TYP‡	MAX	
V _{IK}	V _{CC} = MIN,	I _I = -18 mA			-1.2			-1.2	V
I _{OH}	V _{CC} = MIN,	V _{OH} = 5.5 V					0.25		mA
		V _{IL} = 0.8 V							
		V _{IL} = 0.7 V			0.25				
V _{OL}	V _{CC} = MIN,	V _{IH} = 2 V, I _{OL} = 20 mA			0.5			0.5	V
I _I	V _{CC} = MAX,	V _I = 5.5 V			1			1	mA
I _{IH}	V _{CC} = MAX,	V _I = 2.7 V			50			50	µA
I _{IL}	V _{CC} = MAX,	V _I = 0.5 V			-2			-2	mA
I _{CCH}	V _{CC} = MAX,	V _I = 0 V		9	19.8		9	19.8	mA
I _{CCL}	V _{CC} = MAX,	V _I = 4.5 V		30	54		30	54	mA

† For conditions shown as MIN or MAX, use the appropriate value specified under recommended operating conditions.

‡ All typical values are at V_{CC} = 5 V, T_A = 25°C.

switching characteristics, V_{CC} = 5 V, T_A = 25°C (see Figure 1)

PARAMETER	FROM (INPUT)	TO (OUTPUT)	TEST CONDITIONS		MIN	TYP	MAX	UNIT
t _{PLH}	A	Y	R _L = 280 Ω	C _L = 15 pF	2	5	7.5	ns
t _{PHL}					2	4.5	7	
t _{PLH}				C _L = 50 pF	7.5	ns		
t _{PHL}					7			



PARAMETER MEASUREMENT INFORMATION
SERIES 54/74 AND 54S/74S DEVICES

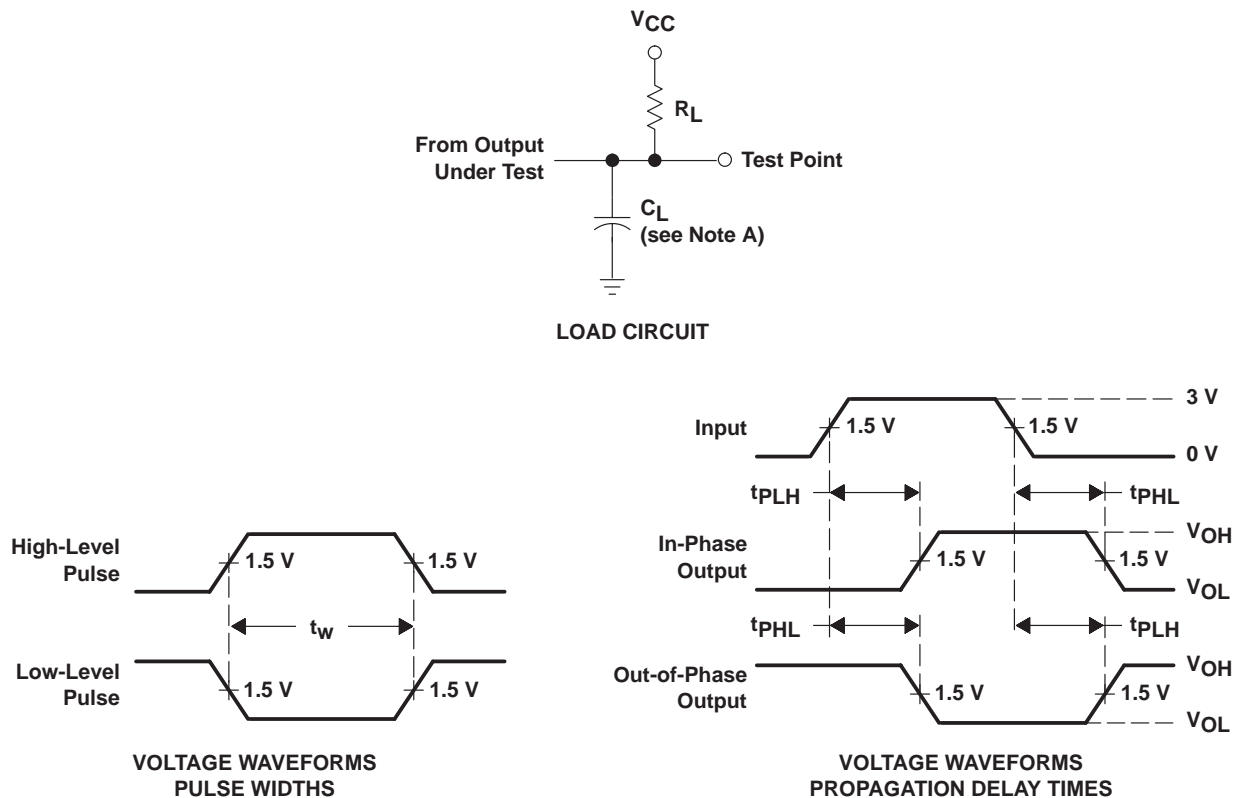

- NOTES: A. C_L includes probe and jig capacitance.
 B. In the examples above, the phase relationships between inputs and outputs have been chosen arbitrarily.
 C. All input pulses are supplied by generators having the following characteristics: $PRR \leq 1$ MHz, $Z_O = 50 \Omega$, and:
 For Series 54/74, $t_r \leq 7$ ns, $t_f \leq 7$ ns.
 For Series 54S/74S, $t_r \leq 2.5$ ns, $t_f \leq 2.5$ ns.
 D. The outputs are measured one at a time with one input transition per measurement.

Figure 1. Load Circuit and Voltage Waveforms

**SN54LS05, SN54S05
SN7405, SN74LS05, SN74S05
HEX INVERTERS WITH OPEN-COLLECTOR OUTPUTS**

SDLS030A – DECEMBER 1983 – REVISED NOVEMBER 2003

The SN5405 is obsolete
and no longer is supplied.

**PARAMETER MEASUREMENT INFORMATION
SERIES 54LS/74LS DEVICES**

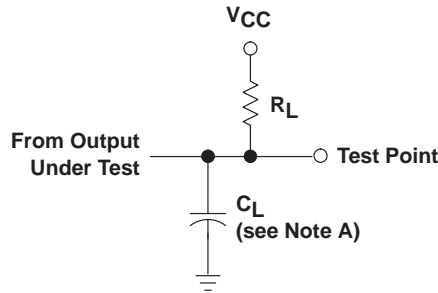

LOAD CIRCUIT

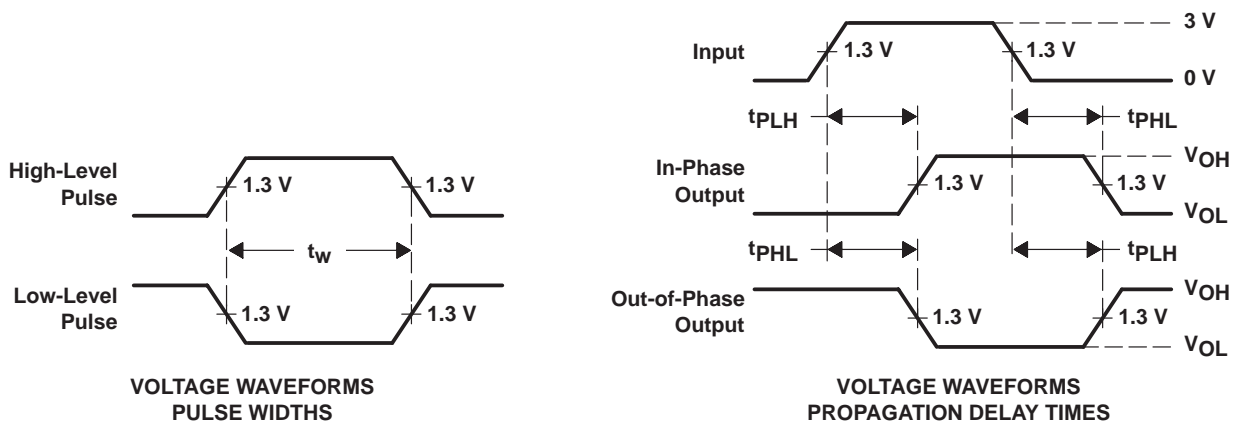

- NOTES: A. C_L includes probe and jig capacitance.
 B. In the examples above, the phase relationships between inputs and outputs have been chosen arbitrarily.
 C. All input pulses are supplied by generators having the following characteristics: $PRR \leq 1$ MHz, $Z_O = 50 \Omega$, $t_r \leq 1.5$ ns, $t_f \leq 2.6$ ns.
 D. The outputs are measured one at a time with one input transition per measurement.

Figure 2. Load Circuit and Voltage Waveforms

PACKAGING INFORMATION

Orderable Device	Status (1)	Package Type	Package Drawing	Pins	Package Qty	Eco Plan (2)	Lead finish/ Ball material (6)	MSL Peak Temp (3)	Op Temp (°C)	Device Marking (4/5)	Samples
JM38510/07004BCA	ACTIVE	CDIP	J	14	25	Non-RoHS & Green	SNPB	N / A for Pkg Type	-55 to 125	JM38510/ 07004BCA	Samples
M38510/07004BCA	ACTIVE	CDIP	J	14	25	Non-RoHS & Green	SNPB	N / A for Pkg Type	-55 to 125	JM38510/ 07004BCA	Samples
SN54LS05J	ACTIVE	CDIP	J	14	25	Non-RoHS & Green	SNPB	N / A for Pkg Type	-55 to 125	SN54LS05J	Samples
SN54S05J	ACTIVE	CDIP	J	14	25	Non-RoHS & Green	SNPB	N / A for Pkg Type	-55 to 125	SN54S05J	Samples
SN7405N	ACTIVE	PDIP	N	14	25	RoHS & Green	NIPDAU	N / A for Pkg Type	0 to 70	SN7405N	Samples
SN7405NE4	ACTIVE	PDIP	N	14	25	RoHS & Green	NIPDAU	N / A for Pkg Type	0 to 70	SN7405N	Samples
SN74LS05D	ACTIVE	SOIC	D	14	50	RoHS & Green	NIPDAU	Level-1-260C-UNLIM	0 to 70	LS05	Samples
SN74LS05DBR	ACTIVE	SSOP	DB	14	2000	RoHS & Green	NIPDAU	Level-1-260C-UNLIM	0 to 70	LS05	Samples
SN74LS05DR	ACTIVE	SOIC	D	14	2500	RoHS & Green	NIPDAU	Level-1-260C-UNLIM	0 to 70	LS05	Samples
SN74LS05N	ACTIVE	PDIP	N	14	25	RoHS & Green	NIPDAU	N / A for Pkg Type	0 to 70	SN74LS05N	Samples
SN74LS05NE4	ACTIVE	PDIP	N	14	25	RoHS & Green	NIPDAU	N / A for Pkg Type	0 to 70	SN74LS05N	Samples
SN74LS05NSR	ACTIVE	SO	NS	14	2000	RoHS & Green	NIPDAU	Level-1-260C-UNLIM	0 to 70	74LS05	Samples
SN74S05D	ACTIVE	SOIC	D	14	50	RoHS & Green	NIPDAU	Level-1-260C-UNLIM	0 to 70	S05	Samples
SN74S05N	ACTIVE	PDIP	N	14	25	RoHS & Green	NIPDAU	N / A for Pkg Type	0 to 70	SN74S05N	Samples
SN74S05NSR	ACTIVE	SO	NS	14	2000	RoHS & Green	NIPDAU	Level-1-260C-UNLIM	0 to 70	74S05	Samples
SNJ54LS05FK	ACTIVE	LCCC	FK	20	55	Non-RoHS & Green	SNPB	N / A for Pkg Type	-55 to 125	SNJ54LS 05FK	Samples
SNJ54LS05J	ACTIVE	CDIP	J	14	25	Non-RoHS & Green	SNPB	N / A for Pkg Type	-55 to 125	SNJ54LS05J	Samples
SNJ54LS05W	ACTIVE	CFP	W	14	25	Non-RoHS & Green	SNPB	N / A for Pkg Type	-55 to 125	SNJ54LS05W	Samples

Orderable Device	Status (1)	Package Type	Package Drawing	Pins	Package Qty	Eco Plan (2)	Lead finish/ Ball material (6)	MSL Peak Temp (3)	Op Temp (°C)	Device Marking (4/5)	Samples
SNJ54S05FK	ACTIVE	LCCC	FK	20	55	Non-RoHS & Green	SNPB	N / A for Pkg Type	-55 to 125	SNJ54S05FK	Samples
SNJ54S05J	ACTIVE	CDIP	J	14	25	Non-RoHS & Green	SNPB	N / A for Pkg Type	-55 to 125	SNJ54S05J	Samples
SNJ54S05W	ACTIVE	CFP	W	14	25	Non-RoHS & Green	SNPB	N / A for Pkg Type	-55 to 125	SNJ54S05W	Samples

(1) The marketing status values are defined as follows:

ACTIVE: Product device recommended for new designs.

LIFEBUY: TI has announced that the device will be discontinued, and a lifetime-buy period is in effect.

NRND: Not recommended for new designs. Device is in production to support existing customers, but TI does not recommend using this part in a new design.

PREVIEW: Device has been announced but is not in production. Samples may or may not be available.

OBSELETE: TI has discontinued the production of the device.

(2) **RoHS:** TI defines "RoHS" to mean semiconductor products that are compliant with the current EU RoHS requirements for all 10 RoHS substances, including the requirement that RoHS substance do not exceed 0.1% by weight in homogeneous materials. Where designed to be soldered at high temperatures, "RoHS" products are suitable for use in specified lead-free processes. TI may reference these types of products as "Pb-Free".

RoHS Exempt: TI defines "RoHS Exempt" to mean products that contain lead but are compliant with EU RoHS pursuant to a specific EU RoHS exemption.

Green: TI defines "Green" to mean the content of Chlorine (Cl) and Bromine (Br) based flame retardants meet JS709B low halogen requirements of <=1000ppm threshold. Antimony trioxide based flame retardants must also meet the <=1000ppm threshold requirement.

(3) MSL, Peak Temp. - The Moisture Sensitivity Level rating according to the JEDEC industry standard classifications, and peak solder temperature.

(4) There may be additional marking, which relates to the logo, the lot trace code information, or the environmental category on the device.

(5) Multiple Device Markings will be inside parentheses. Only one Device Marking contained in parentheses and separated by a "-" will appear on a device. If a line is indented then it is a continuation of the previous line and the two combined represent the entire Device Marking for that device.

(6) Lead finish/Ball material - Orderable Devices may have multiple material finish options. Finish options are separated by a vertical ruled line. Lead finish/Ball material values may wrap to two lines if the finish value exceeds the maximum column width.

Important Information and Disclaimer:The information provided on this page represents TI's knowledge and belief as of the date that it is provided. TI bases its knowledge and belief on information provided by third parties, and makes no representation or warranty as to the accuracy of such information. Efforts are underway to better integrate information from third parties. TI has taken and continues to take reasonable steps to provide representative and accurate information but may not have conducted destructive testing or chemical analysis on incoming materials and chemicals. TI and TI suppliers consider certain information to be proprietary, and thus CAS numbers and other limited information may not be available for release.

In no event shall TI's liability arising out of such information exceed the total purchase price of the TI part(s) at issue in this document sold by TI to Customer on an annual basis.

OTHER QUALIFIED VERSIONS OF SN54LS05, SN54S05, SN74LS05, SN74S05 :

- Catalog : [SN74LS05](#), [SN74S05](#)
- Military : [SN54LS05](#), [SN54S05](#)

NOTE: Qualified Version Definitions:

- Catalog - TI's standard catalog product
- Military - QML certified for Military and Defense Applications

TAPE AND REEL INFORMATION

QUADRANT ASSIGNMENTS FOR PIN 1 ORIENTATION IN TAPE

*All dimensions are nominal

Device	Package Type	Package Drawing	Pins	SPQ	Reel Diameter (mm)	Reel Width W1 (mm)	A0 (mm)	B0 (mm)	K0 (mm)	P1 (mm)	W (mm)	Pin1 Quadrant
SN74LS05DBR	SSOP	DB	14	2000	330.0	16.4	8.35	6.6	2.4	12.0	16.0	Q1
SN74LS05DR	SOIC	D	14	2500	330.0	16.4	6.5	9.0	2.1	8.0	16.0	Q1
SN74LS05NSR	SO	NS	14	2000	330.0	16.4	8.2	10.5	2.5	12.0	16.0	Q1
SN74S05NSR	SO	NS	14	2000	330.0	16.4	8.2	10.5	2.5	12.0	16.0	Q1

TAPE AND REEL BOX DIMENSIONS

*All dimensions are nominal

Device	Package Type	Package Drawing	Pins	SPQ	Length (mm)	Width (mm)	Height (mm)
SN74LS05DBR	SSOP	DB	14	2000	356.0	356.0	35.0
SN74LS05DR	SOIC	D	14	2500	356.0	356.0	35.0
SN74LS05NSR	SO	NS	14	2000	356.0	356.0	35.0
SN74S05NSR	SO	NS	14	2000	356.0	356.0	35.0

TUBE

*All dimensions are nominal

Device	Package Name	Package Type	Pins	SPQ	L (mm)	W (mm)	T (µm)	B (mm)
SN7405N	N	PDIP	14	25	506	13.97	11230	4.32
SN7405N	N	PDIP	14	25	506	13.97	11230	4.32
SN7405NE4	N	PDIP	14	25	506	13.97	11230	4.32
SN7405NE4	N	PDIP	14	25	506	13.97	11230	4.32
SN74LS05D	D	SOIC	14	50	506.6	8	3940	4.32
SN74LS05N	N	PDIP	14	25	506	13.97	11230	4.32
SN74LS05N	N	PDIP	14	25	506	13.97	11230	4.32
SN74LS05NE4	N	PDIP	14	25	506	13.97	11230	4.32
SN74LS05NE4	N	PDIP	14	25	506	13.97	11230	4.32
SN74S05D	D	SOIC	14	50	506.6	8	3940	4.32
SN74S05N	N	PDIP	14	25	506	13.97	11230	4.32
SN74S05N	N	PDIP	14	25	506	13.97	11230	4.32
SNJ54LS05FK	FK	LCCC	20	55	506.98	12.06	2030	NA
SNJ54LS05W	W	CFP	14	25	506.98	26.16	6220	NA
SNJ54S05FK	FK	LCCC	20	55	506.98	12.06	2030	NA

MECHANICAL DATA

NS (R-PDSO-G**)

PLASTIC SMALL-OUTLINE PACKAGE

14-PINS SHOWN



- NOTES:
- A. All linear dimensions are in millimeters.
 - B. This drawing is subject to change without notice.
 - C. Body dimensions do not include mold flash or protrusion, not to exceed 0,15.

W (R-GDFP-F14)

CERAMIC DUAL FLATPACK



4040180-2/F 04/14

- NOTES:
- A. All linear dimensions are in inches (millimeters).
 - B. This drawing is subject to change without notice.
 - C. This package can be hermetically sealed with a ceramic lid using glass frit.
 - D. Index point is provided on cap for terminal identification only.
 - E. Falls within MIL STD 1835 GDFP1-F14

DB0014A

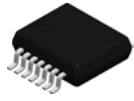

PACKAGE OUTLINE

SSOP - 2 mm max height

SMALL OUTLINE PACKAGE



NOTES:

1. All linear dimensions are in millimeters. Any dimensions in parenthesis are for reference only. Dimensioning and tolerancing per ASME Y14.5M.
2. This drawing is subject to change without notice.
3. This dimension does not include mold flash, protrusions, or gate burrs. Mold flash, protrusions, or gate burrs shall not exceed 0.15 mm per side.
4. Reference JEDEC registration MO-150.

EXAMPLE BOARD LAYOUT

DB0014A

SSOP - 2 mm max height

SMALL OUTLINE PACKAGE

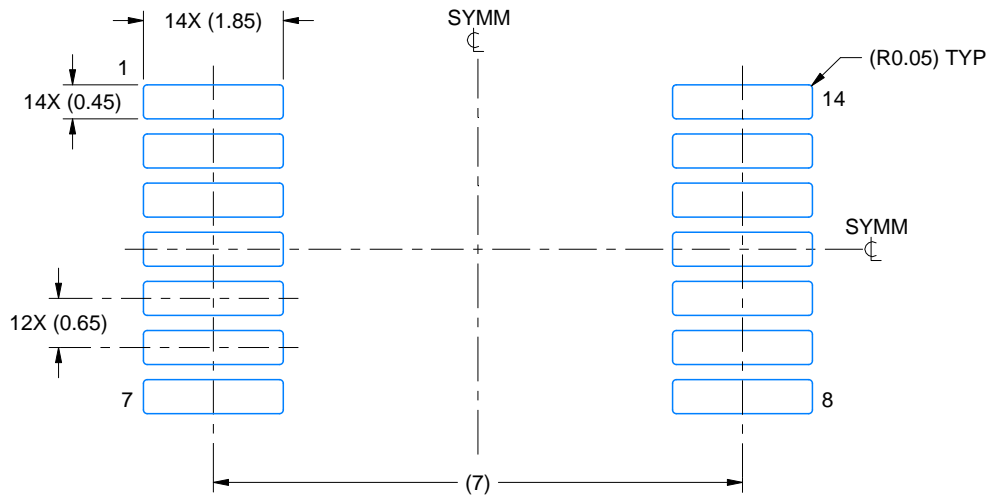

LAND PATTERN EXAMPLE
EXPOSED METAL SHOWN
SCALE: 10X



4220762/A 05/2024

NOTES: (continued)

5. Publication IPC-7351 may have alternate designs.
6. Solder mask tolerances between and around signal pads can vary based on board fabrication site.

EXAMPLE STENCIL DESIGN

DB0014A

SSOP - 2 mm max height

SMALL OUTLINE PACKAGE



SOLDER PASTE EXAMPLE
BASED ON 0.125 mm THICK STENCIL
SCALE: 10X

4220762/A 05/2024

NOTES: (continued)

7. Laser cutting apertures with trapezoidal walls and rounded corners may offer better paste release. IPC-7525 may have alternate design recommendations.
8. Board assembly site may have different recommendations for stencil design.

GENERIC PACKAGE VIEW

FK 20

LCCC - 2.03 mm max height

8.89 x 8.89, 1.27 mm pitch

LEADLESS CERAMIC CHIP CARRIER

This image is a representation of the package family, actual package may vary.
Refer to the product data sheet for package details.



4229370VA\

J 14

GENERIC PACKAGE VIEW
CDIP - 5.08 mm max height
CERAMIC DUAL IN LINE PACKAGE

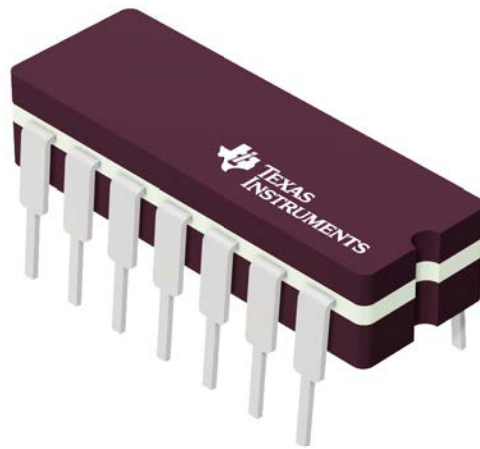

Images above are just a representation of the package family, actual package may vary.
Refer to the product data sheet for package details.

4040083-5/G

J0014A



PACKAGE OUTLINE

CDIP - 5.08 mm max height

CERAMIC DUAL IN LINE PACKAGE



4214771/A 05/2017

NOTES:

1. All controlling linear dimensions are in inches. Dimensions in brackets are in millimeters. Any dimension in brackets or parenthesis are for reference only. Dimensioning and tolerancing per ASME Y14.5M.
2. This drawing is subject to change without notice.
3. This package is hermetically sealed with a ceramic lid using glass frit.
4. Index point is provided on cap for terminal identification only and on press ceramic glass frit seal only.
5. Falls within MIL-STD-1835 and GDIP1-T14.

EXAMPLE BOARD LAYOUT

J0014A

CDIP - 5.08 mm max height

CERAMIC DUAL IN LINE PACKAGE



LAND PATTERN EXAMPLE
NON-SOLDER MASK DEFINED
SCALE: 5X



4214771/A 05/2017

D (R-PDSO-G14)

PLASTIC SMALL OUTLINE



- NOTES:
- A. All linear dimensions are in inches (millimeters).
 - B. This drawing is subject to change without notice.
 - $\triangle C$ Body length does not include mold flash, protrusions, or gate burrs. Mold flash, protrusions, or gate burrs shall not exceed 0.006 (0,15) each side.
 - $\triangle D$ Body width does not include interlead flash. Interlead flash shall not exceed 0.017 (0,43) each side.
 - E. Reference JEDEC MS-012 variation AB.

D (R-PDSO-G14)

PLASTIC SMALL OUTLINE



- NOTES:
- A. All linear dimensions are in millimeters.
 - B. This drawing is subject to change without notice.
 - C. Publication IPC-7351 is recommended for alternate designs.
 - D. Laser cutting apertures with trapezoidal walls and also rounding corners will offer better paste release. Customers should contact their board assembly site for stencil design recommendations. Refer to IPC-7525 for other stencil recommendations.
 - E. Customers should contact their board fabrication site for solder mask tolerances between and around signal pads.

N (R-PDIP-T**)

PLASTIC DUAL-IN-LINE PACKAGE

16 PINS SHOWN



4040049/E 12/2002

- NOTES:
- A. All linear dimensions are in inches (millimeters).
 - B. This drawing is subject to change without notice.
 - (C) Falls within JEDEC MS-001, except 18 and 20 pin minimum body length (Dim A).
 - (D) The 20 pin end lead shoulder width is a vendor option, either half or full width.

IMPORTANT NOTICE AND DISCLAIMER

TI PROVIDES TECHNICAL AND RELIABILITY DATA (INCLUDING DATA SHEETS), DESIGN RESOURCES (INCLUDING REFERENCE DESIGNS), APPLICATION OR OTHER DESIGN ADVICE, WEB TOOLS, SAFETY INFORMATION, AND OTHER RESOURCES "AS IS" AND WITH ALL FAULTS, AND DISCLAIMS ALL WARRANTIES, EXPRESS AND IMPLIED, INCLUDING WITHOUT LIMITATION ANY IMPLIED WARRANTIES OF MERCHANTABILITY, FITNESS FOR A PARTICULAR PURPOSE OR NON-INFRINGEMENT OF THIRD PARTY INTELLECTUAL PROPERTY RIGHTS.

These resources are intended for skilled developers designing with TI products. You are solely responsible for (1) selecting the appropriate TI products for your application, (2) designing, validating and testing your application, and (3) ensuring your application meets applicable standards, and any other safety, security, regulatory or other requirements.

These resources are subject to change without notice. TI grants you permission to use these resources only for development of an application that uses the TI products described in the resource. Other reproduction and display of these resources is prohibited. No license is granted to any other TI intellectual property right or to any third party intellectual property right. TI disclaims responsibility for, and you will fully indemnify TI and its representatives against, any claims, damages, costs, losses, and liabilities arising out of your use of these resources.



TI's products are provided subject to [TI's Terms of Sale](#) or other applicable terms available either on [ti.com](https://www.ti.com) or provided in conjunction with such TI products. TI's provision of these resources does not expand or otherwise alter TI's applicable warranties or warranty disclaimers for TI products.

TI objects to and rejects any additional or different terms you may have proposed.

Mailing Address: Texas Instruments, Post Office Box 655303, Dallas, Texas 75265
Copyright © 2024, Texas Instruments Incorporated

Looking for pricing, stock, or lifecycle information?

Click below to explore more details on WIN SOURCE:

-  [View SG2013J on WIN SOURCE](#)
-  [Microchip Technology](#) Information

Optimize Your Supply Chain with WIN SOURCE Solutions

-  Global Sourcing Solution
-  Obsolete Management
-  Cost Control Management
-  Shortage Management
-  Alternative Solution
-  Excess Inventory Management