

LED Drivers for LCD Backlights

White Backlight LED Driver for Medium to Large LCD Panels (Switching Regulator Type)



BD6592MUV

No.11040ECT33

●Description

BD6592MUV is white LED driver IC with PWM step-up DC/DC converter that can boost max 42.5V and current driver that can drive max 40mA. The wide and precision brightness can be controlled by external PWM pulse. BD6592MUV has very accurate current drivers, and it has few current errors between each strings. So, it will be helpful to reduce brightness spots on the LCD. Small package type is suited for saving space.

●Features

- 1) High efficiency PWM step-up DC/DC converter (fsw=1MHz), max efficiency 93%
- 2) High accuracy & good matching ($\pm 3\%$) current drivers 6ch
- 3) Drive up to 12 in series, 6 strings in parallel =72 white LEDs (white LED Vf=3.5Vmax)
- 4) Wide input voltage range (2.7V ~ 22V)
- 5) Rich safety functions
 - Over-voltage protection (OVP)
 - Over current limit
 - External SBD open detect
 - Thermal shutdown
- 6) Small & thin package (VQFN024V4040) 4.0 × 4.0 × 1.0mm

●Applications

All middle size LCD equipments backlight of Notebook PC, portable DVD player, car navigation systems, etc.

●Absolute maximum ratings (Ta=25°C)

Parameter	Symbol	Ratings	Unit	Condition
Maximum applied voltage 1	VMAX1	7	V	TEST, VREG, SENSP, SENSN, SW, RSTB, PWMPOW, PWMDRV, FAILSEL, ISETH, ISETL
Maximum applied voltage 2	VMAX2	25	V	LED1, LED2, LED3, LED4, LED5, LED6, VBAT
Maximum applied voltage 3	VMAX3	50.5	V	VDET
Power dissipation 1	Pd1	500	mW	*1
Power dissipation 2	Pd2	780	mW	*2
Power dissipation 3	Pd3	1510	mW	*3
Operating temperature range	Topr	-30 ~ +85	°C	
Storage temperature range	Tstg	-55 ~ +150	°C	

*1 Reduced 4.0mW/°C With Ta>25°C when not mounted on a heat radiation Board.

*2 1 layer (ROHM Standard board) has been mounted. Copper foil area 0mm², When it's used by more than Ta=25°C, it's reduced by 6.2mW/°C.

*3 4 layer (JEDEC Compliant board) has been mounted.

Copper foil area 1layer 6.28mm², Copper foil area 2~4layers 5655.04mm², When it's used by more than Ta=25°C, it's reduced by 12.1mW/°C.

●Recommended operating range (Ta=-30°C ~ +85°C)

Parameter	Symbol	Ratings			Unit	Condition
		Min.	Typ.	Max.		
Power supply voltage	VBAT	2.7	12.0	22.0	V	

● **Electrical characteristic** (Unless otherwise specified, VBAT=12V, RSTB=2.5V, Ta = +25°C)

Parameter	Symbol	Limits			Unit	Condition
		Min.	Typ.	Max.		
[FALSEL,PWM DRV Terminal]						
EN threshold voltage (Low)	VthL	0	-	0.2	V	
EN threshold voltage (High) 1	VthH1	1.4	-	5.0	V	VBAT>5.0V
EN threshold voltage (High) 2	VthH2	1.4	-	VBAT	V	VBAT<5.0V
EN terminal input current	lin	-	8.3	14.0	μA	Input=2.5V
[PWMPow Terminal]						
Low Input Voltage range	PWML	0	-	0.2	V	
High Input Voltage range1	PWMH1	1.4	-	5.0	V	VBAT>5.0V
High Input Voltage range2	PWMH2	1.4	-	VBAT	V	VBAT<5.0V
PWM pull down resistor	PWMR	300	500	700	kΩ	
[RSTB Terminal]						
Low Input Voltage range	RSTBL	0	-	0.2	V	
High Input Voltage range1	RSTBH1	2.25	2.5	5.0	V	VBAT>5.0V
High Input Voltage range2	RSTBH2	2.25	2.5	VBAT	V	VBAT<5.0V
Current Consumption	IRSTB	-	89	134	μA	RSTB=2.5V, LED1-6=3V
[Regulator]						
VREG Voltage	VREG	4.0	5.0	6.0	V	No load
Under Voltage Lock Out	UVLO	2.05	2.25	2.65	V	
[Switching Regulator]						
Quiescent Current 1	Iq1	-	0.6	3.4	μA	RSTB=0V, VBAT=12V
Quiescent Current 2	Iq2	-	4.6	10	μA	RSTB=0V, VBAT=22V
Current Consumption	Idd	-	3.4	5.1	mA	VDET=0V, ISETH=24kΩ
LED Control voltage	VLED	0.4	0.5	0.6	V	
Over Current Limit voltage	Ocp	70	100	130	mV	*1
SBD Open Protect	Sop	-	-	0.1	V	Detect voltage of VDET pin
Switching frequency	fSW	0.8	1.0	1.2	MHz	
Duty cycle limit	Duty	92.5	95.0	99.0	%	LED1-6=0.3V
Over voltage limit	Ovl	43.0	44.7	46.4	V	LED1-6=0.3V
[Current driver]						
LED maximum current	ILMAX	-	-	40	mA	
LED current accuracy	ILACCU	-	-	±5	%	ILED=30mA
LED current matching	ILMAT	-	-	±3	%	▪Each LED current/Average (LED1- 6) ▪ILED=30mA
ISET voltage	Iset	0.5	0.6	0.7	V	
LED Terminal Over Voltage Protect	LEDOVP	10.0	11.5	13.0	V	RSTB=PWM DRV=2.5V

*1 This parameter is tested with DC measurement.

●Reference data

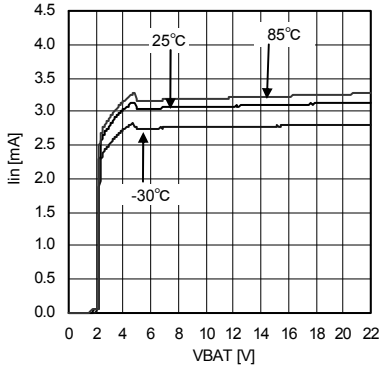

Fig.1
Current Consumption - VBAT

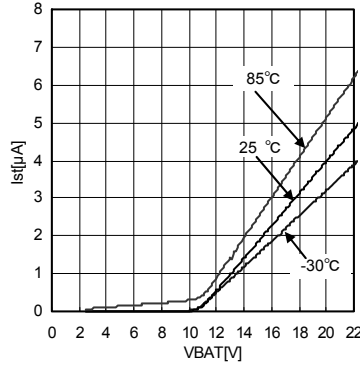

Fig.2
Quiescent current - VBAT

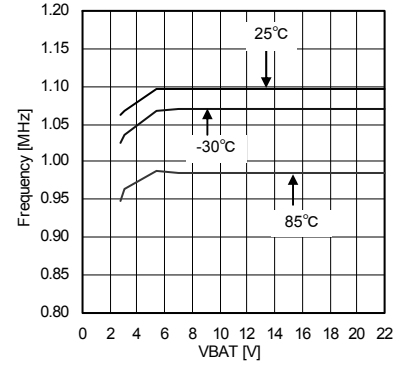

Fig.3
Oscillation frequency - VBAT

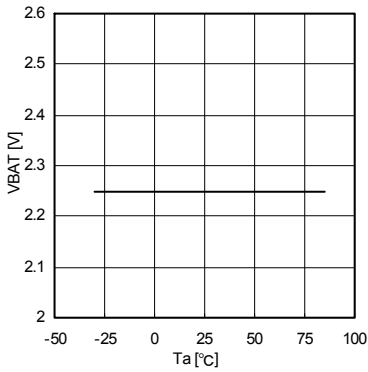

Fig.4
UVLO - Temperature

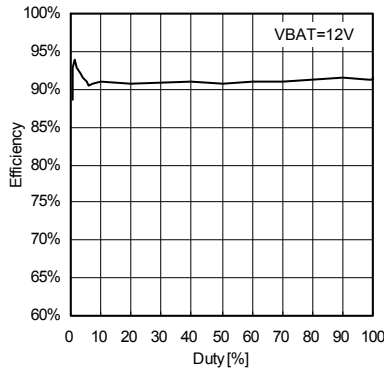

Fig.5
Efficiency - PWMPOW-HI Duty
ISETH=24kΩ, PWM=200Hz

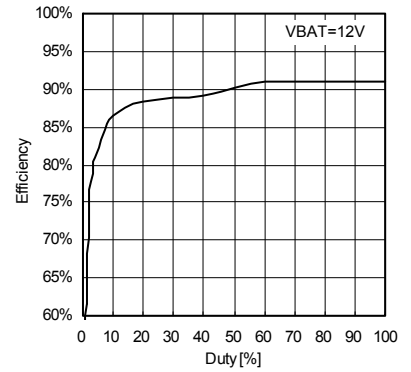

Fig.6
Efficiency - PWMDRV-HI Duty
ISETH=24kΩ, PWM=200Hz

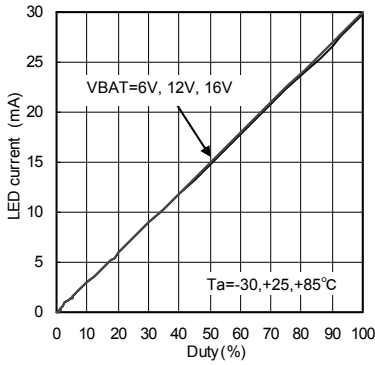

Fig.7
LED current - PWMDRV-HI Duty
PWM = 200Hz

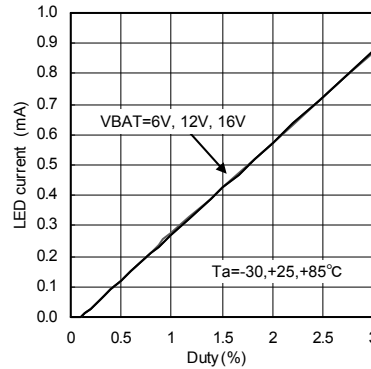

Fig.8
LED current - PWMDRV-HI Duty
(Expansion) PWM = 200Hz

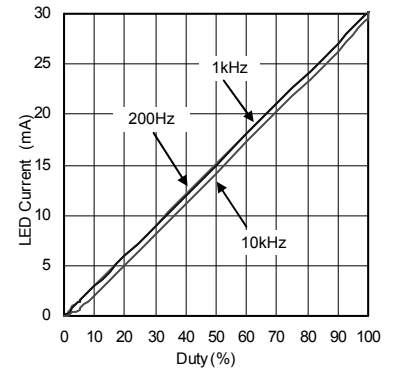

Fig.9
LED current - PWMDRV-HI Duty
PWM = 200Hz, 1kHz, 10kHz

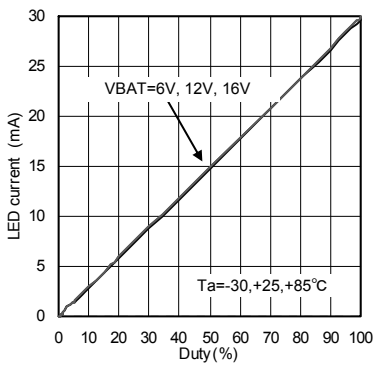

Fig.10
LED current - PWMPOW-HI Duty
PWM = 200Hz

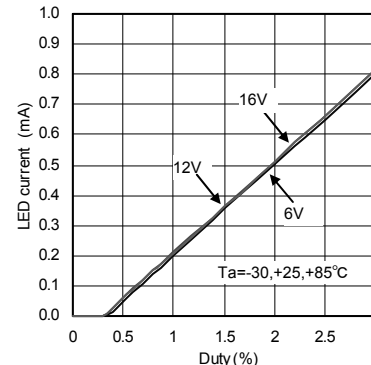

Fig.11
LED current - PWMPOW-HI Duty
(Expansion) PWM = 200Hz

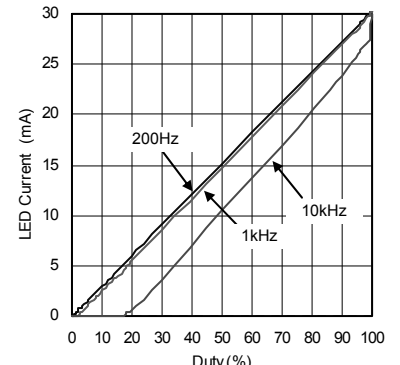

Fig.12
LED current - PWMPOW-HI Duty
PWM = 200Hz, 1kHz, 10kHz

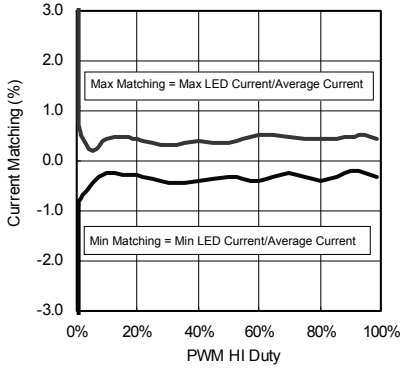

Fig.13
LED current matching - PWMDRV-HI Duty
PWM = 200Hz

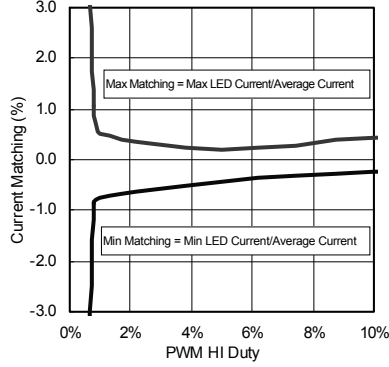

Fig.14
LED current matching - PWMDRV-HI Duty
(Expansion) PWM = 200Hz

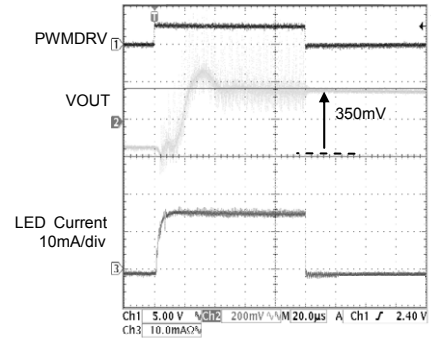

Fig.15
VOUT response
Driver Control PWM (PWMDRV)

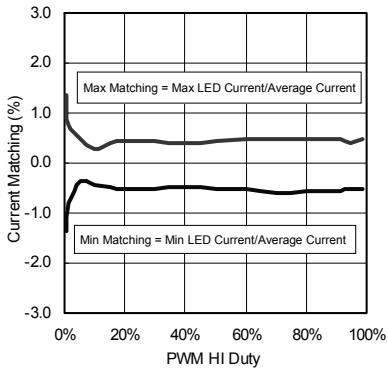

Fig.16
LED current matching - PWMPOW-HI Duty
PWM = 200Hz

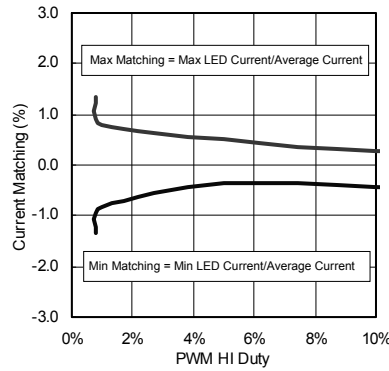

Fig.17
LED current matching - PWMPOW-HI Duty
(Expansion) PWM = 200Hz

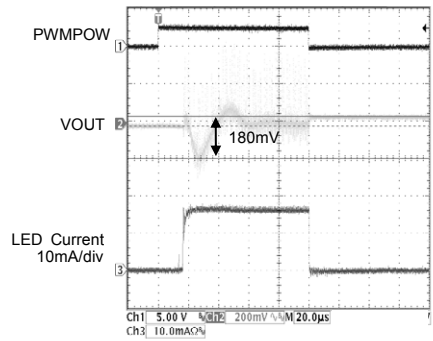

Fig.18
VOUT response
Power Control PWM (PWMPOW)

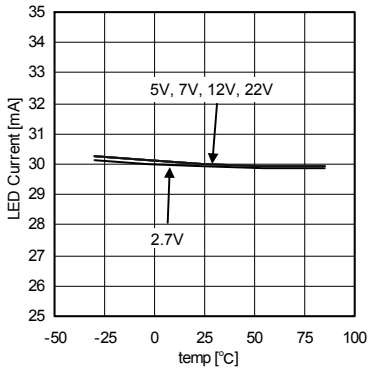

Fig.19
LED current - Temperature
PWMDRV=H, ISETH=30kΩ (16mA setting)

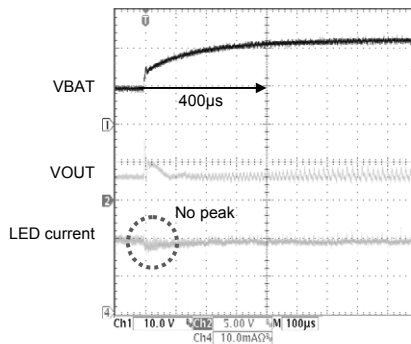

Fig.20
Line Transient (10V to 22V)

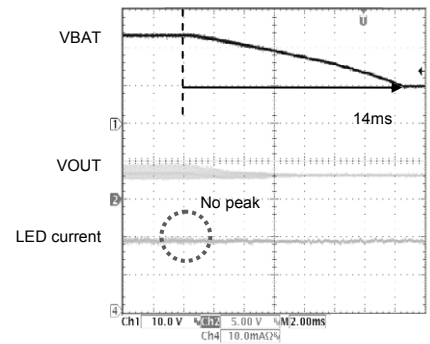

Fig.21
Line Transient (22V to 10V)

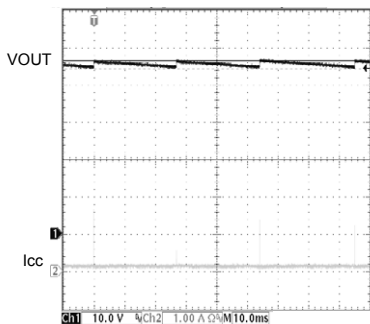

Fig.22
VOUT@OVP (LED OPEN)

●Block diagram, I/O equivalent circuit diagram

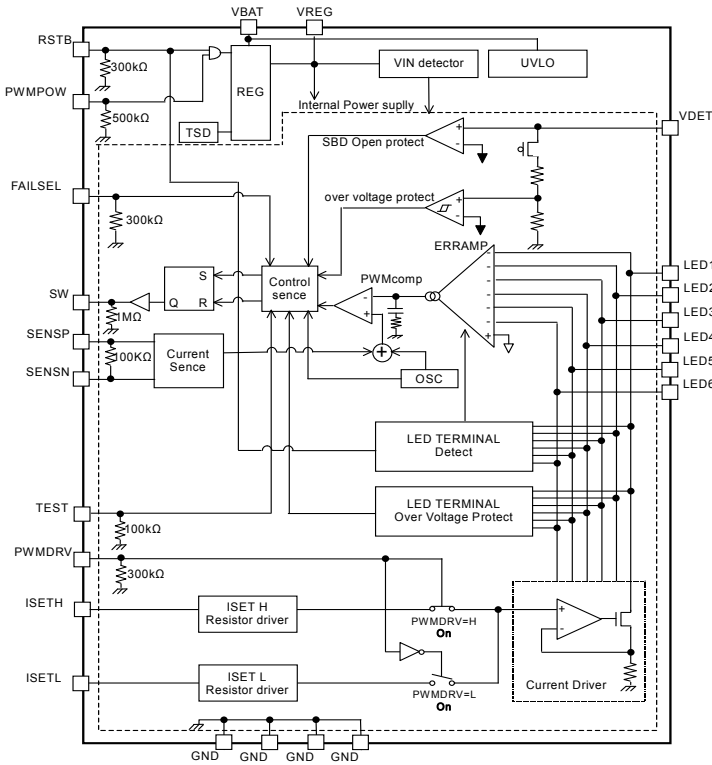

Fig.23 Block diagram

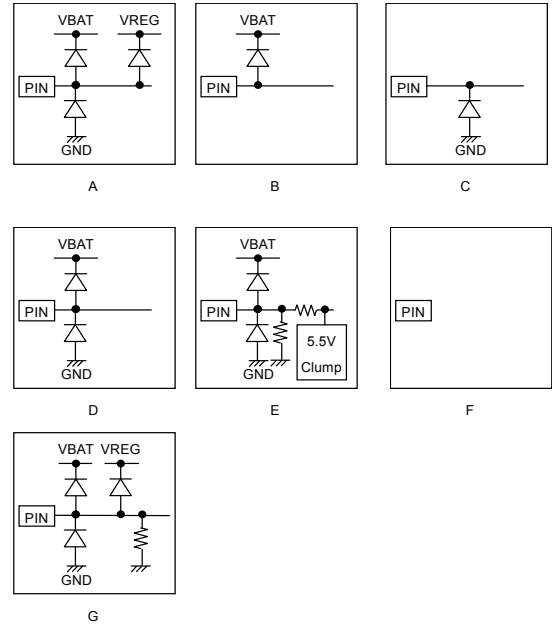

Fig.24 I/O equivalent circuit diagram

●Pin assignment table

PIN Name	In/Out	PIN number	Function	Terminal equivalent circuit diagram
1	VDET	In	Detect input for SBD open and OVP	C
2	N.C.	-	No connect pin	F
3	GND	-	GND	B
4	SW	Out	Switching Tr drive terminal	G
5	SENSP	In	+ Side Current sense terminal	G
6	TEST	In	TEST input (Pull down 100kΩ to GND)	G
7	SENSN	In	- Side Current sense terminal	A
8	GND	-	GND	B
9	ISETH	In	Resistor connection for LED current setting at PWMDRV=H	A
10	ISETL	In	Resistor connection for LED current setting at PWMDRV=L	A
11	PWMDRV	In	PWM input pin for power ON/OFF only driver	E
12	LED1	In	Current sink for LED1	C
13	LED2	In	Current sink for LED2	C
14	LED3	In	Current sink for LED3	C
15	GND	-	GND	B
16	LED4	In	Current sink for LED4	C
17	LED5	In	Current sink for LED5	C
18	LED6	In	Current sink for LED6	C
19	FAILSEL	In	Latch selectable pin of protect function	E
20	GND	-	GND	B
21	RSTB	In	Reset pin L :Reset H :Reset cancel	E
22	VREG	Out	Regulator output / Internal power-supply	D
23	PWMPow	In	PWM input pin for power ON/OFF	E
24	VBAT	In	Battery input	C

●Application example

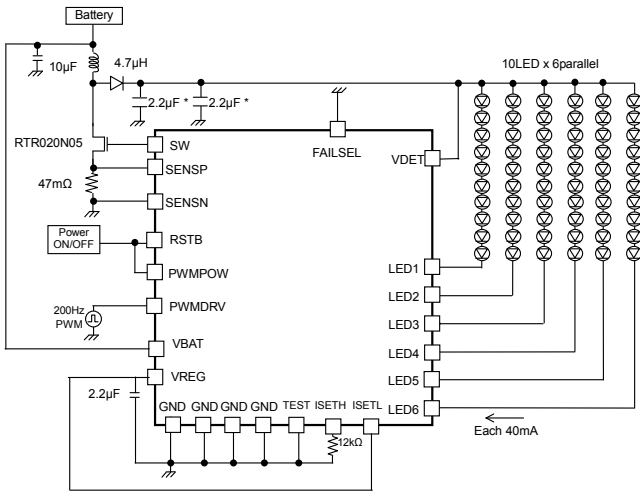

Fig.25 10 series x 6parallel
Hi current 40mA setting
Current driver PWM application

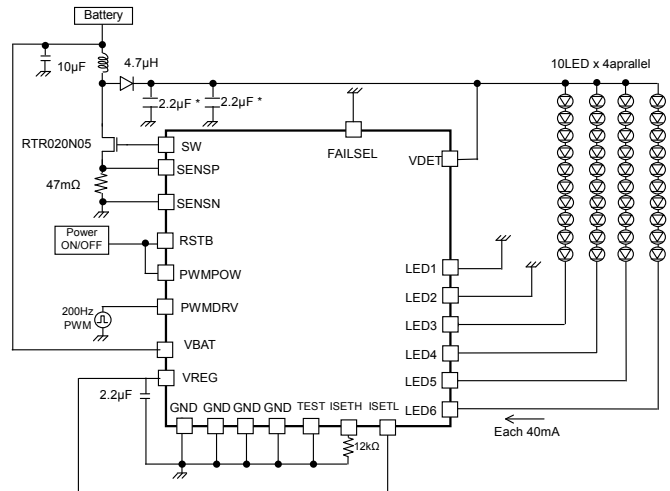

Fig.26 10 series x 4parallel
Hi current 40mA setting
Current driver PWM application

* Please select the capacitor which the little bias fluctuation.

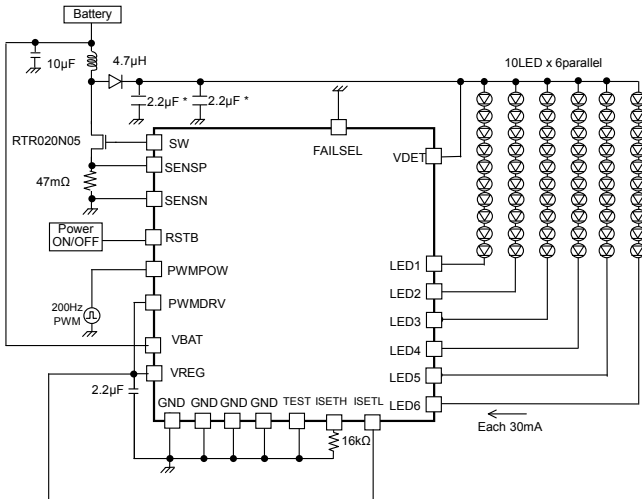

Fig.27 10 series x 6parallel LED current 30mA setting
Power control PWM application

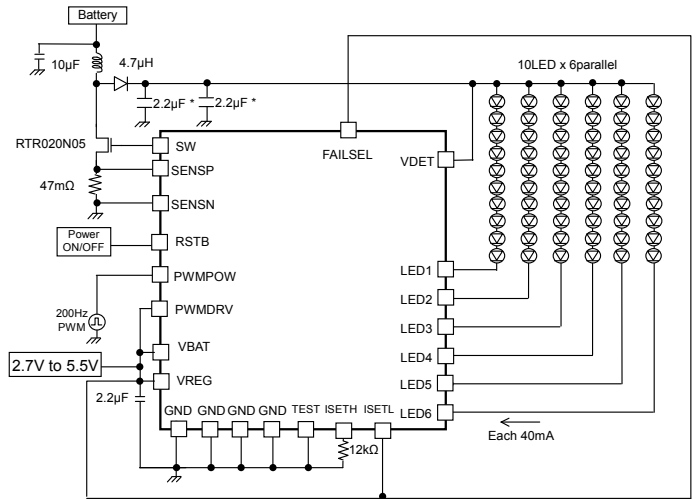

Fig.28 Non-used Inside REG
or operating under 5V application

* Please select the capacitor which the little bias fluctuation.

●Terminal processing

TEST pin= Connect to GND

N.C. = Nothing specified in particular. Open is recommended.

VREG= When IC is driving from the outside of 2.7~5.5V, short VBAT and VREG, and put the voltage to VREG

FAILSEL, PWMDRV= Connect to GND in case of fixing at L level. Connect to VREG of IC or the power supply of more than 1.4V in case of fixing at H level .

LED1-6= When each LED driver are not used, connect to GND of IC

GND = Each GND is connecting inside IC, but, connect to GND of all board

RSTB= RSTB is used as a power supply of internal circuit.

So, you mustn't input RSTB voltage with pull up resistor of several kΩ. And, please care about the relation between VBAT and RSTB enough. (ref. P9)

●Description of Functions

1)PWM current mode DC/DC converter

While BD6592MUV is power ON, the lowest voltage of LED1, 2, 3, 4, 5, 6 is detected, PWM duty is decided to be 0.5V and output voltage is kept invariably. As for the inputs of the PWM comparator as the feature of the PWM current mode, one is overlapped with error components from the error amplifier, and the other is overlapped with a current sense signal that controls the inductor current into Slope waveform to prevent sub harmonic oscillation. This output controls external Nch Tr via the RS latch. In the period where external Nch Tr gate is ON, energy is accumulated in the external inductor, and in the period where external Nch Tr gate is OFF, energy is transferred to the output capacitor via external SBD. BD6592MUV has many safety functions, and their detection signals stop switching operation at once.

2)Soft start

BD6592MUV has soft start function.

The soft start function prevents large coil current.

Rush current at turning on is prevented by the soft start function.

After RSTB is changed L→ H, when PWMPow is changed L→ H, soft start becomes effective for within 1ms and soft start doesn't become effective even if PWMPow is changed L→ H after that.

And, when the H section of PWMPow is within 1ms, soft start becomes invalid when PWMPow is input to H more than three times. The invalid of the soft start can be canceled by making RSTB → L.

3)FAILSEL pin

When the error condition occurs, boost operating is stopped by the protection function, and the error condition is avoided. On that occasion, the way to stop of boost operating by the protection function can be selected with FAILSEL pin. Details are as shown in Fig.29, 30.

After power ON, when the protection function is operating under about 1ms have passed, the stop state of the boost operating can be held through FAILSEL is H, the stop state can reset through RSTB is L.

And, boost operating is stopped when the protection function is operating through FAILSEL is L, but when the protection function becomes un-detect, boost operating is started again. It never keeps holding the stop state of boost operating.

In PWM control by PWMDRV can't use this function.
When it is off over 10ms on PWM control by PWMPow using this function, it may be stopped the boost operating as over current protection work at off on PWMPow=L.

Object of protect function is as shown below.

- Over-voltage protection
- External SBD open detect
- Thermal shutdown
- LED terminal over-voltage protection
- Over current limit

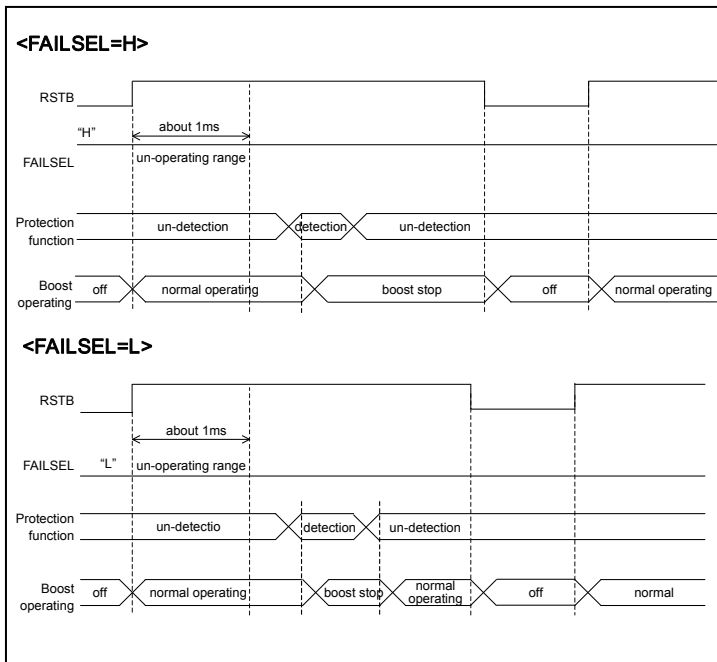

Fig.29 FAILSEL operating description

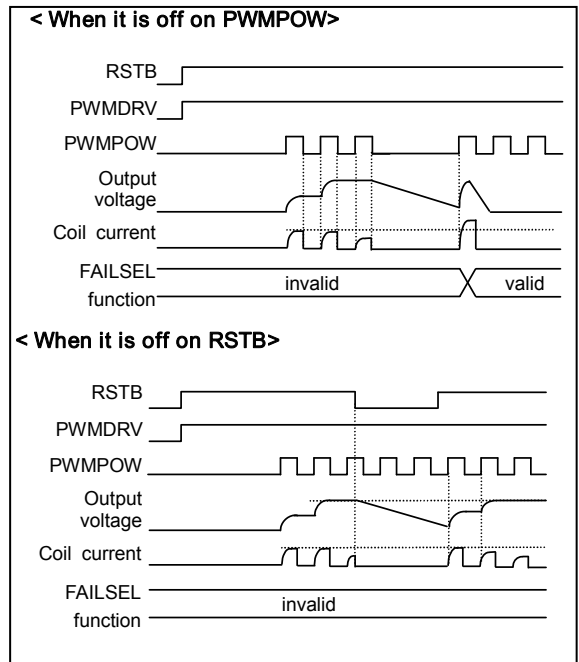

Fig.30 FAILSEL=H light off control

4) External SBD open detect and over voltage protection

BD6592MUV has over boost protection by external SBD open and over voltage protection. It detects VDET voltage and is stopped output Tr in abnormal condition. Details are as shown below.

- External SBD open detect

In the case of external SBD is not connected to IC, the coil or external Tr may be destructed. Therefore, at such an error as VOUT becoming 0.1V or below, the Under Detector shown in the figure works, and turns off the output Tr, and prevents the coil and the IC from being destructed.

And the IC changes from activation into non-activation, and current does not flow to the coil (0mA).

- Over voltage protection

At such an error of output open as the output DC/DC and the LED is not connected to IC, the DC/DC will boost too much and the VDET terminal exceed the absolute maximum ratings, and may destruct the IC.

Therefore, when VDET becomes sensing voltage or higher, the over voltage limit works, and turns off the output Tr, and the pressure up made stop.

At this moment, the IC changes from activation into non-activation, and the output voltage goes down slowly. And, when the output voltage becomes the hysteresis of the over voltage limit or below, the output voltage pressure up to sensing voltage once again and unless the application error is recovered, this operation is repeated.

5) Thermal shut down

BD6592MUV has thermal shut down function.

The thermal shut down works at 175°C or higher, and the IC changes from activation into non-activation. Because non-activation is different from RSTB=L, it doesn't be reset inside IC. Moreover, even if thermal shut down function works, soft start, FAILSEL, selection the number of LED lines of the current driver and starting current setting at PWMDRV=L related RSTB are hold.

6) Over Current Limit

Over current flows the current detection resistor that is connected to switching transistor source and between GND, SENSP pin voltage turns more than detection voltage, over current protection is operating and it is prevented from flowing more than detection current by reducing ON duty of switching Tr without stopping boost.

As over current detector of BD6592MUV is detected peak current, current more than over current setting value does not flow. And, over current value can decide freely by changing over current detection voltage.

<Derivation sequence of detection resistor>

Detection resistor = Over current detection voltage / Over current setting value

TYP value of over current detection voltage is 100mV, MIN = 70mV and MAX = 130mV and after the current value which was necessary for the normal operation was decided, detection resistor is derived by using MIN value of over current detection value.

For example, detection resistor when necessary current value was set at 1A is given as shown below.

Detection resistor = 70mV / 1A = 70mΩ

MAX current dispersion of this detection resistor value is

MAX current = 130mV / 70mΩ = 1.86A

<The estimate of the current value which need for the normal operation >

As over current detector of BD6592MUV is detected the peak current, it have to estimate peak current to flow to the coil by operating condition.

In case of, ○ Supply voltage of coil = VIN

○ Inductance value of coil = L

○ Switching frequency = fsw MIN=0.8MHz, Typ=1MHz, MAX=1.2MHz

○ Output voltage = VOUT

○ Total LED current = IOUT

○ Average current of coil = Iave

○ Peak current of coil = Ipeak

○ Efficiency = eff (Please set up having margin, it refers to data on p.3.)

○ ON time of switching transistor = Ton

$I_{peak} = (VIN / L) \times (1 / fsw) \times (1 - (VIN / VOUT))$

$I_{ave} = (VOUT \times IOUT / VIN) / eff$

$Ton = (I_{ave} \times (1 - VIN/VOUT) \times (1/fsw) \times (L/VIN) \times 2)^{1/2}$

Each current is calculated.

As peak current varies according to whether there is the direct current superposed, the next is decided.

$(1 - VIN/VOUT) \times (1/fsw) < Ton \rightarrow peak\ current = I_{peak} / 2 + I_{ave}$

$(1 - VIN/VOUT) \times (1/fsw) > Ton \rightarrow peak\ current = I_{peak}$

(Example 1)

In case of, VIN=6.5V, L=4.7μH, fsw=1MHz, VOUT=39V, IOU=80mA, Efficiency=85%
 $I_{peak} = (6.5V / 4.7\mu H) \times (1 / 1MHz) \times (1 - (6.5V / 39V)) = 1.08A$
 $I_{ave} = (39V \times 80mA / 6.0V) / 85\% = 0.61A$
 $T_{on} = (0.61A \times (1 - 6.0V / 39V) \times (1 / 1MHz) \times (4.7\mu H / 6.0V) \times 2)^{1/2} = 0.90\mu s$
 $(1 - VIN/VOUT) \times (1/fsw) = 0.85\mu s < T_{on}$
 Peak current = 1.08A/2+0.61A = 1.15A

(Example 2)

In case of, VIN=12.0V, L=4.7μH, fsw=1MHz, VOUT=39V, IOU=80mA, Efficiency=85%
 $I_{peak} = (12.0V / 4.7\mu H) \times (1 / 1MHz) \times (1 - (12V / 39V)) = 1.77A$
 $I_{ave} = (39V \times 80mA / 12.0V) / 85\% = 0.31A$
 $T_{on} = (0.31A \times (1 - 12V / 39V) \times (1 / 1MHz) \times (4.7\mu H / 12V) \times 2)^{1/2} = 0.41\mu s$
 $(1 - VIN/VOUT) \times (1/fsw) = 0.69\mu s > T_{on}$
 Peak current = 12V/4.7μH × 0.41μs = 1.05A

When too large current is set, output overshoot is caused, be careful enough because it is led to break down of the IC in case of the worst.

●Operating of the application deficiency

- 1)When 1 LED or 1parallel OPEN during the operating
 In case of FAILSEL=L, the LED parallel which became OPEN isn't lighting, but other LED parallel is lighting. At that time, output boosts up to the over voltage protection voltage 44.7V so that LED terminal may be 0V or it boost to the output voltage that LED terminal voltage becomes LED terminal over voltage protection 11.5V or it becomes the output voltage restricted by the over current limit. In case of FAILSEL=H, boost stops when LED becomes OPEN and all LED turns off the lights.
- 2)When LED short-circuited in the plural
 In case of FAILSEL=L, all LED is turned on unless LED terminal voltage is LED terminal over voltage protection of more than 11.5V. When it was more than 11.5V only the line which short-circuited is turned on normally and LED current of other lines fall or turn off the lights. In case of FAILSEL=H, boost stops at more than 11.5V and all LED turns off the lights.
- 3)When Schottky diode came off
 Regardless of FAILSEL, all LED isn't turned on. Also, IC and a switching transistor aren't destroyed because boost operating stops by the Schottky diode coming off protected function.
- 4)When over current detection resistor came off
 Regardless of FAILSEL, all LED isn't turned on. Because the resistance of 100kΩ is between SENSEP and SENSEN terminal, over current protection works instantly and LED current can't be flow.

●Control signal input timing

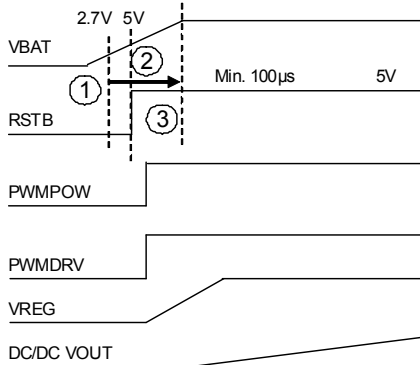

Fig.31 Control signal timing

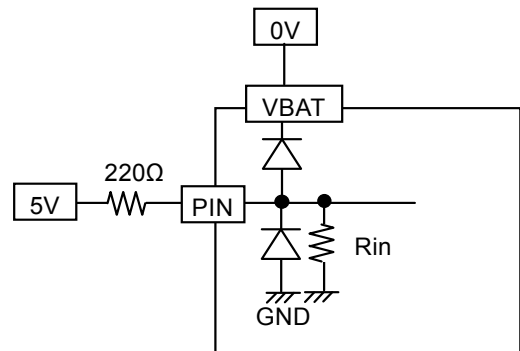

Fig.32 Voltage with a control sign higher than VBAT
 Example corresponding to application of conditions

In case you input control signs, such as RSTB, PWMPOW, and PWMDRV, in the condition that the standup of supply voltage (VBAT) is not completed, be careful of the following point.

- ① Input each control signal after VBAT exceeds 2.7V.
- ② Please do not input each control sign until VBAT exceeds HI voltage of RSTB, PWMPOW, and PWMDRV.
- ③ When you input RSTB during the standup of VBAT and HI voltage is inputted into PWMPOW, please give the standup time to stable voltage as Min.100μs 2.7V of VBAT.

There is no timing limitation at each input signal of RSTB, PWMPOW and PWMDRV.

If each control sign changes into a condition lower than VBAT in (1) and (2), it goes via the ESD custody diode by the side of VBAT of each terminal. A power supply is supplied to VBAT and there is a possibility of malfunctioning. Moreover, when the entrance current to the terminal exceeds 50mA, it has possibility to damage the LSI. In order to avoid this condition, as shown in the above figure, please insert about 220ohm in a signal line, and apply current qualification. Please confirm an internal pull down resistor in the block diagram and electrical property of P.5.

●Attendance point of the restriction resistance input to RSTB

When the restriction resistance is input to RSTB, it is necessary to consider the input current of RSTB.

The input current of RSTB changes that depending on the power-supply voltage and the temperature reference to Fig.33. Because the temperature characteristic of the input current is shown in Fig.33, please choose resistance for which the voltage of the terminal can be guaranteed to 2.1V or more.

And, it has the margin in the decision of resistance, and please confirm and make sure it is no problem in a real application.

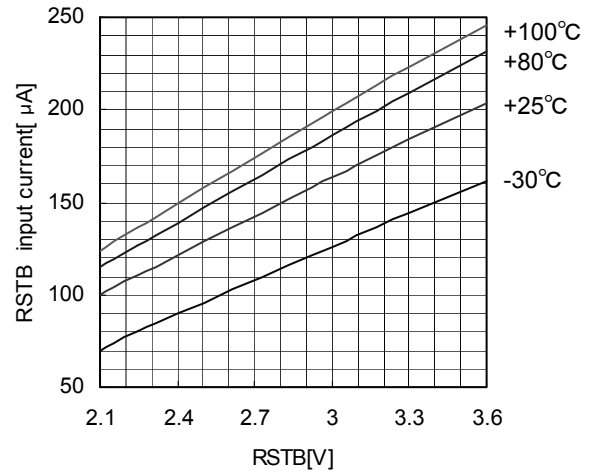
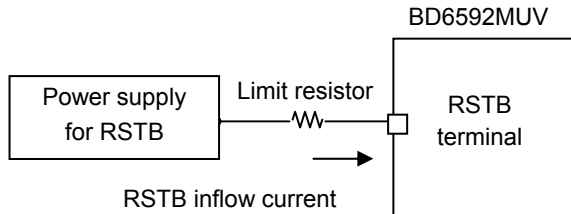

Fig.33 RSTB terminal voltage-RSTB inflow current
(At the time of the current driver six lines use)

The decision example of restriction resistance

1. When use the current driver of 6 parallel
 $2.9V(\text{to RSTB power-supply}) - \text{restriction resistance value} \times 124\mu A(100^\circ C \text{ input current}) > 2.1V$
 $\text{restriction resistance value} < (2.9-2.1)/124\mu A=6.45k\Omega$
2. 2. When use the current driver of 3 parallel
 $2.9V(\text{to RSTB power-supply}) - \text{restriction resistance value} \times 430\mu A(100^\circ C \text{ input current}) > 2.1V$
 $\text{restriction resistance value} < (2.9-2.1)/430\mu A=1.86k\Omega$

In addition, the selection number of parallel number of the current driver is changed, the power-supply current of RSTB will be increased. Because the maximum value of the consumption current at the RSTB=2.1V is indicated in the following Table 1, be careful enough when you calculate the restriction resistance.

Table1. The use parallel number of current driver at RSTB=2.1V , 100°C vs. RSTB input current

Parallel numbers used for current driver	RSTB input current
6	0.12mA
5	0.23mA
4	0.33mA
3	0.43mA
2	0.53mA
1	0.63mA
0	0.74mA

●How to select the number of LED lines of the current driver

When the number of LED lines of the current driver is reduced, the un-select can be set the matter that the unnecessary LED1 ~ 6 terminal is connected to GND. When it uses with 4 lines and so on, it can correspond to it by connecting 2 unnecessary lines to GND. RSTB is used as a power supply of this decision circuit. The select of the terminal is judged, It has no relation to the logic of PWMPOW and PWMDRV and it isn't judged an unnecessary LED line even if it is connected to GND when it is judged a necessary terminal once. This information can be reset by setting RSTB at 0V.

●Start control and select LED current driver

BD6592MUV can control the IC system by RSTB, and IC can power off compulsory by setting 0.2V or below. Also, It powers on PWMPOW is at more than 1.4V and RSTB is at more than 2.25V.

When RSTB=PWMPOW=H, ISETH current is selected at PWMDRV=H and ISETL current is selected at PWMDRV=L.

The starting current in PWMDRV=L sets OFF second time rise of PWMDRV and it becomes 0mA setting after that.

After RSTB sets L once, the starting current can be flowed again by changing it to H.

RSTB	PWMPOW	PWMDRV	IC	LED current
H	L	L	Off	OFF
H	H	L	On	Starting current decided with ISETL
H	L	H	Off	OFF
H	H	H	On	Current decided with ISETH
L	L, H	L, H	Off	OFF

●Start to use PWMPow terminal for the PWM control, PWM operating

After RSTB and PWMDRV is changing L → H, input PWM to PWMPow terminal.

There is no constraint in turn of RSTB and PWMDRV.

And, because it corresponds to PWM drive of shorter ON time than soft start time (1ms), when PWMPow is input H more than three times, the soft start is invalidated and it enable to correspond the high-speed drive. Until RSTB is set L, invalidation of the soft start isn't canceled.

In case of lighting → light off → lighting, when it turns off the lights with PWM=L and It starts without soft start when it sets PWM modulated light again.

But the peak current of the coil changes owing to discharge of output capacitor, It may flow to the over current limit value, as follows Fig.34. Because soft start can be used when it turns off the lights with RSTB=L, The peak current of the coil can be suppressed, as follows Fig.35 and this process of light off is recommended.

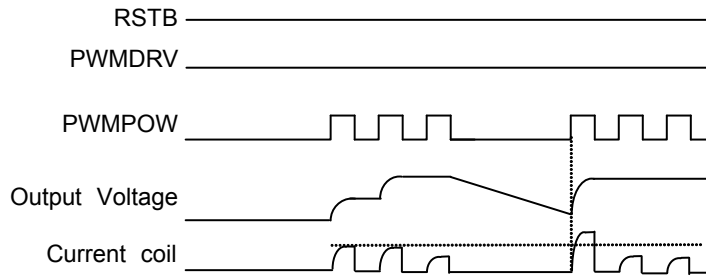

Fig.34 Light off control of PWMPow pin at PWM control on PWM=L

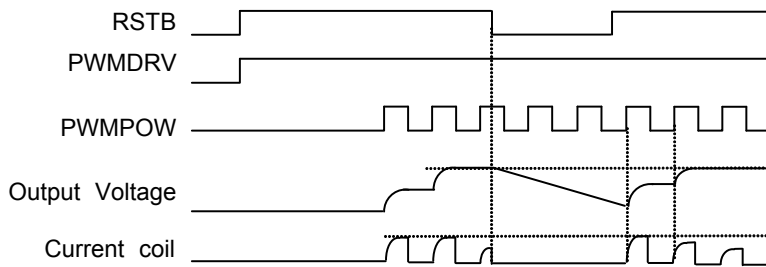

Fig.35 Light off control of PWMPow pin at PWM control on RSTB=L

●Start to use PWMDRV terminal for the PWM control, PWM operating

After RSTB and PWMPOW is changing L → H, input PWM to PWMDRV terminal.

There is no constraint in turn of RSTB and PWMPOW.

When resistance is set as ISET, after RSTB and PWMPOW is changing L → H as follows Fig.36, when it is not input PWM to PWMDRV pin but input L, boost of DC/DC is unstable state because current driver doesn't pass current.

The starting current is pulled from each LED terminal and pressure up operating is stabilized to escape from this state.

Also, the starting current can be set up by the resistance value connected to the ISETL terminal.

After starting, as the starting current in PWM brightness control become useless, the starting current is set up 0mA at the second rise time of PWMDRV automatically as follows Fig.37.

In case of lighting → light off → lighting, when it turns off the lights with PWM=L and It starts without soft start because of soft start period was end when it sets PWM modulated light again.

But the peak current of the coil changes owing to discharge of output capacitor, It may flow to the over current limit value, as follows Fig.37. Because soft start can be used when it turns off the lights with RSTB=L, The peak current of the coil can be suppressed, as follows Fig.38 and this process of light off is recommended.

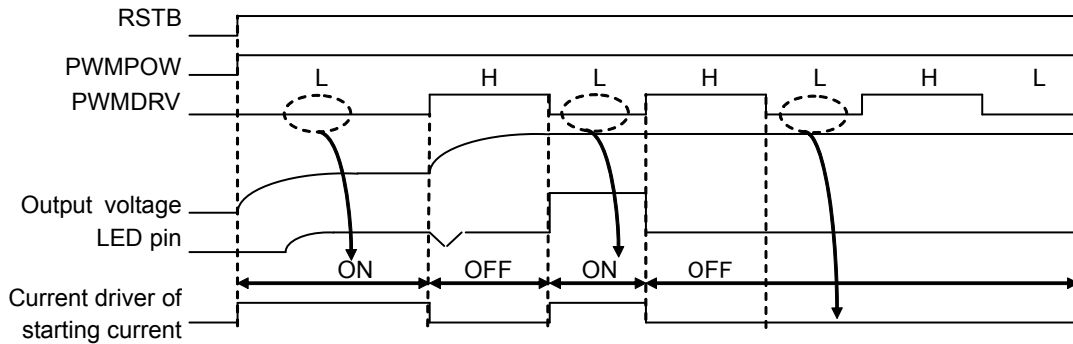

Fig.36 Off timing of starting current at PWMDRV=L

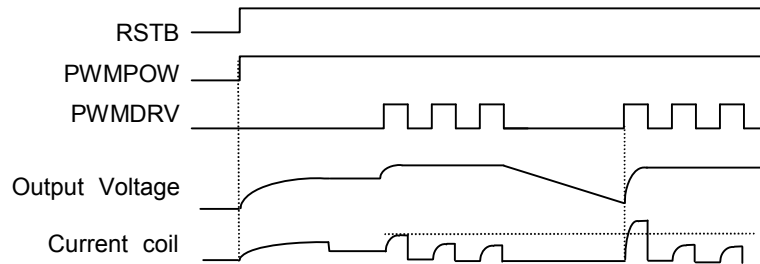

Fig.37 Light off control of PWMDRV pin at PWM control on PWM=L

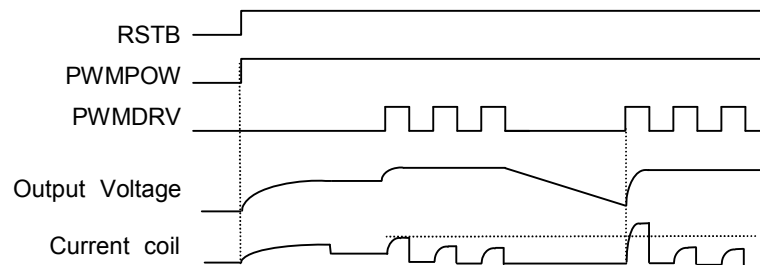

Fig.38 Light off control of PWMDRV pin at PWM control on RSTB=L

●Brightness control

There are two dimming method is available, first method is analog dimming that apply analog voltage to ISET terminal, and second method is PWM control via digital dimming of PWMPOW or PWMDRV. Because each method has the different merit, please choose a suitable method for the application of use.

Two techniques can be used as digital dimming by the PWM control One is PWM control of current driver, the other is PWM control of power control.

As these two characteristics are shown in the below, selects to PWM control process comply with application.

- Efficiency emphasis in the low brightness which has an influence with the battery life → 2) Power control PWM control
- LED current dispersion emphasis in the PWM brightness control → 1) Current driver PWM control

(Reference)

PWM regulation process	Efficiency of LED current 0.5mA (PWM Duty=2.5%)	PWM frequency 200Hz Limit dispersion capability of low duty
Current driver	70%	0.2%
Power control	93%	0.5%

1)Current driver PWM control is controlled by providing PWM signal to PWMDRV, as it is shown Fig.25.

The current set up with ISETH is chosen as the Hi section of PWMDRV and the current is off as the Lo section. Therefore, the average LED current is increasing in proportion to duty cycle of PWMDRV signal. This method that it lets internal circuit and DC/DC to work, because it becomes to switch the driver, the current tolerance is a few when the PWM brightness is adjusted, it makes it possible to brightness control until 20μs (MIN0.4% at 200Hz). And, don't use for the brightness control, because effect of ON/OFF changeover is big under 20μs ON time and under 20μs OFF time. There is no effect of ON/OFF changeover at 0% and 100%, so there is no problem on use. Typical PWM frequency is 100Hz~10kHz. When resistance is set as ISET, RSTB sets H → L, so the starting current may be effective, after RSTB sets L → H, it becomes PWM of the starting current and PWM of ISETH setting current to PWM two times.

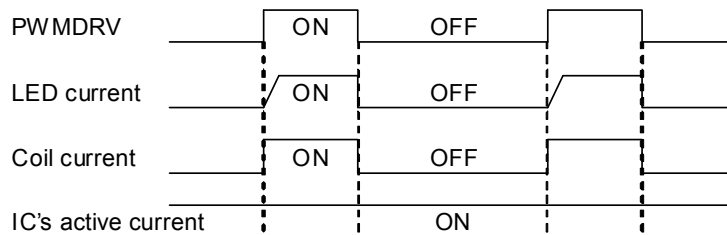

Fig.39

2)Power control PWM control is controlled by providing PWM signal to PWMPOW, as it is shown Fig.27. The current setting set up with PWMDRV logic is chosen as the Hi section and the current is off as the Lo section. Therefore, the average LED current is increasing in proportion to duty cycle of PWMPOW signal. This method is, because IC can be power-off at off-time, the consumption current can be suppress, and the high efficiency can be available, so it makes it possible to brightness control until 50μs (MIN1% at 200Hz). And, don't use for the brightness control, because effect of power ON/OFF time changeover is big under 50μs ON time and under 50μs OFF time.

There is no effect of ON/OFF changeover at 0% and 100%, so there is no problem on use. Typical PWM frequency is 100Hz~1kHz. Also, PWM can't control RSTB and PWMPOW at the same time.

After RSTB sets H, control PWM only PWMPOW.

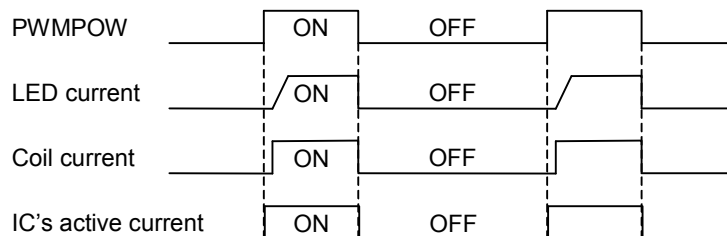

Fig.40

●LED current setting range

LED current can set up Normal and Starting setting current.

LED current can set up Normal current by resistance value (RISETH) connecting to ISETH voltage and LED current can set Starting current by resistance value (RISETL) connecting to ISETL voltage.

Setting of each LED current is given as shown below.

Normal current = $20\text{mA}(24\text{k}\Omega/\text{RISETH})$

Starting constant current = $0.6/\text{RISETL}$

Also, Normal current setting range is 10mA~25mA, Starting current setting range is OFF setting or 1μA~100μA.

LED current can set OFF setting by open setting ISETL pin.

LED current becomes a leak current MAX 1μA at OFF setting.

ISETH Normal current setting example

RISETH	LED current
12kΩ (E12)	40mA
16 kΩ (E16)	30mA
24kΩ (E24)	20mA
25.5 kΩ (E96)	18.8mA
27 kΩ (E12)	17.8mA
30kΩ (E24)	16.0mA

ISETL Starting current setting example

RISETL	LED current
6.2kΩ (E24)	97μA
10kΩ (E6)	60μA
47kΩ (E6)	13μA
100 kΩ (E6)	6μA
560 kΩ (E12)	1.1μA
Connect to VREG pin	0mA

●The separations of the IC Power supply and coil Power supply

This IC can work in separating the power source in both IC power supply and coil power supply. With this application, it can obtain that decrease of IC power consumption, and the applied voltage exceeds IC rating 22V.

That application is shown in below Fig 41. The higher voltage source is applied to the power source of coil that is connected from an adapter etc. Next, the IC power supply is connected with a different coil power supply. Under the conditions for inputting from 2.7V to 5.5V into IC VBAT, please follow the recommend design in Fig 38. It connects VBAT terminal and VREG terminal together at IC outside.

When the coil power supply is applied, it is no any problem even though IC power supply is the state of 0V. Although IC power supply is set to 0V, pull-down resistance is arranged for the power off which cuts off the leak route from coil power supply in IC inside, the leak route is cut off. And, there is no power on-off sequence of coil power supply and IC power supply.

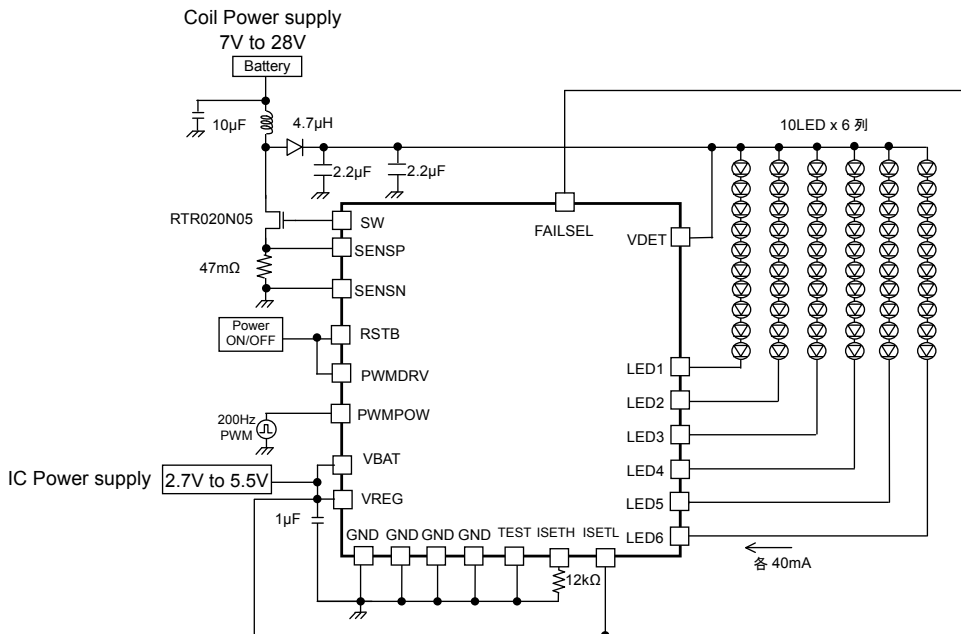

Fig.42 Application at the time of power supply isolation

●The coil selection

The DC/DC is designed by more than $4.7\mu\text{H}$. When L value sets to a lower value, it is possibility that the specific sub-harmonic oscillation of current mode DC / DC will be happened.

Please do not let L value to $3.3\mu\text{H}$ or below.

And, L value increases, the phase margin of DC / DC becomes to zero. Please enlarge the output capacitor value when you increase L value.

Example)

$4.7\mu\text{H}$	=	output capacitor	$2.2\mu\text{F}/50\text{V}$	1pcs
$6.8\mu\text{H}$	=	output capacitor	$2.2\mu\text{F}/50\text{V}$	2pcs
$10\mu\text{H}$	=	output capacitor	$2.2\mu\text{F}/50\text{V}$	3pcs

This value is just examples, please made sure the final judgment is under an enough evaluation.

●PCB layout

In order to make the most of the performance of this IC, its PCB layout is very important. Characteristics such as efficiency and ripple and the likes change greatly with layout patterns, which please note carefully.

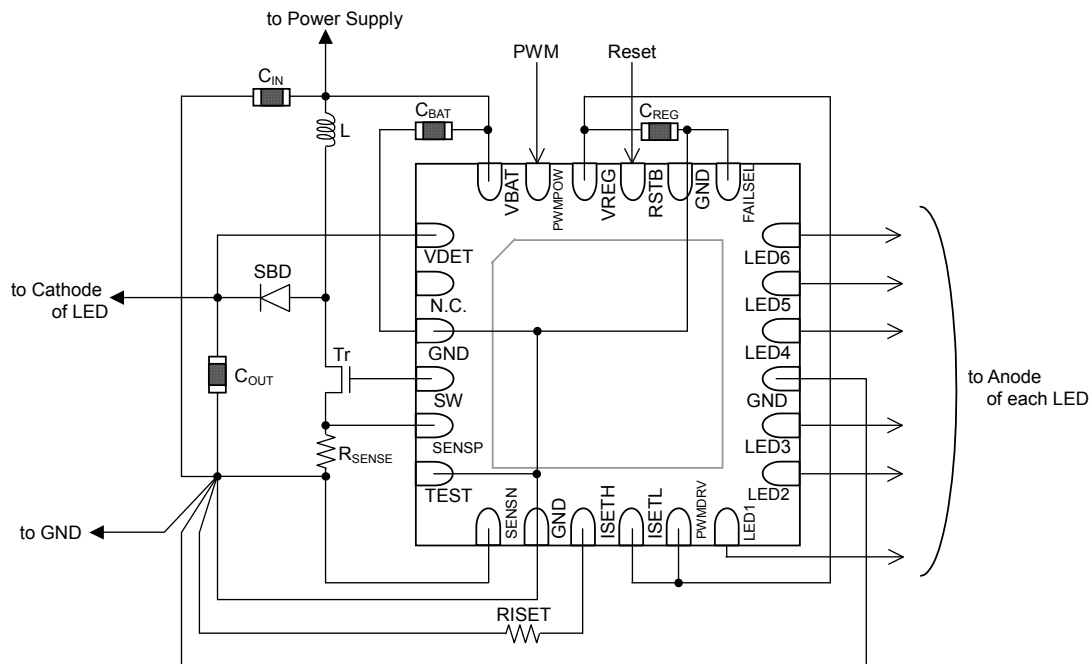

Fig.42 Layout

Connect the input bypass capacitor $C_{IN}(10\mu\text{F})$ nearest to coil L, as shown in the upper diagram.

Wire the power supply line by the low resistance from C_{IN} to VBAT pin. Thereby, the input voltage ripple of the IC can be reduced. Connect smoothing capacitor C_{REG} of the regulator nearest to between VREG and GND pin, as shown in the upper diagram. Connect schottky barrier diode SBD of the regulator nearest to between coil L and switching transistor Tr.

And connect output capacitor C_{OUT} nearest to between C_{IN} and GND pin. Thereby, the output voltage ripple of the IC can be reduced.

Connect switching transistor Tr nearest to SW pin. Wire coil L and switching transistor Tr, current sensing resistor R_{SENSE} by the low resistance. Wiring to the SENSE pin isn't Tr side, but connect it from R_{SENSE} side. Over current value may become low when wiring from Tr side. Connect R_{SENSE} of GND side isolated to SENSE pin. Don't wire between R_{SENSE} and SENSE pin wiring from R_{SENSE} pin to GND pin. **And R_{SENSE} GND line must be wired directly to GND pin of output capacitor.** It has the possibility that restricts the current drive performance by the influence of the noise when other GND is connected to this GND.

Connect LED current setting resistor R_ISET nearest to ISET pin. **There is possibility to oscillate when capacity is added to ISET terminal, so pay attention that capacity isn't added. And, R_ISET of GND side must be wired directly to GND pin.**

When those pins are not connected directly near the chip, influence is given to the performance of BD6592MUV, and may limit the current drive performance. As for the wire to the inductor, make its resistance component small so as to reduce electric power consumption and increase the entire efficiency.

The layout pattern in consideration of these is shown in next page.

●Recommended PCB layout pattern

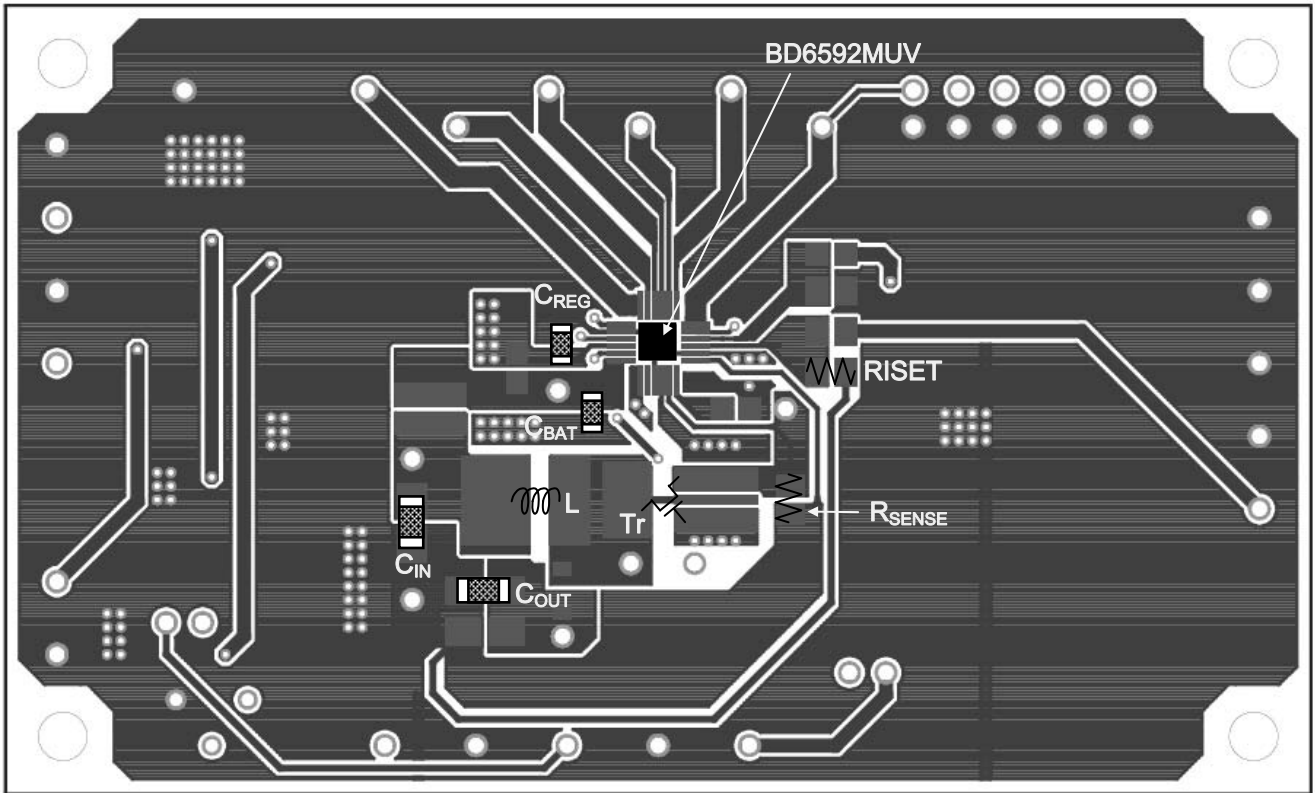

Fig.43 Frontal surface <Top view>

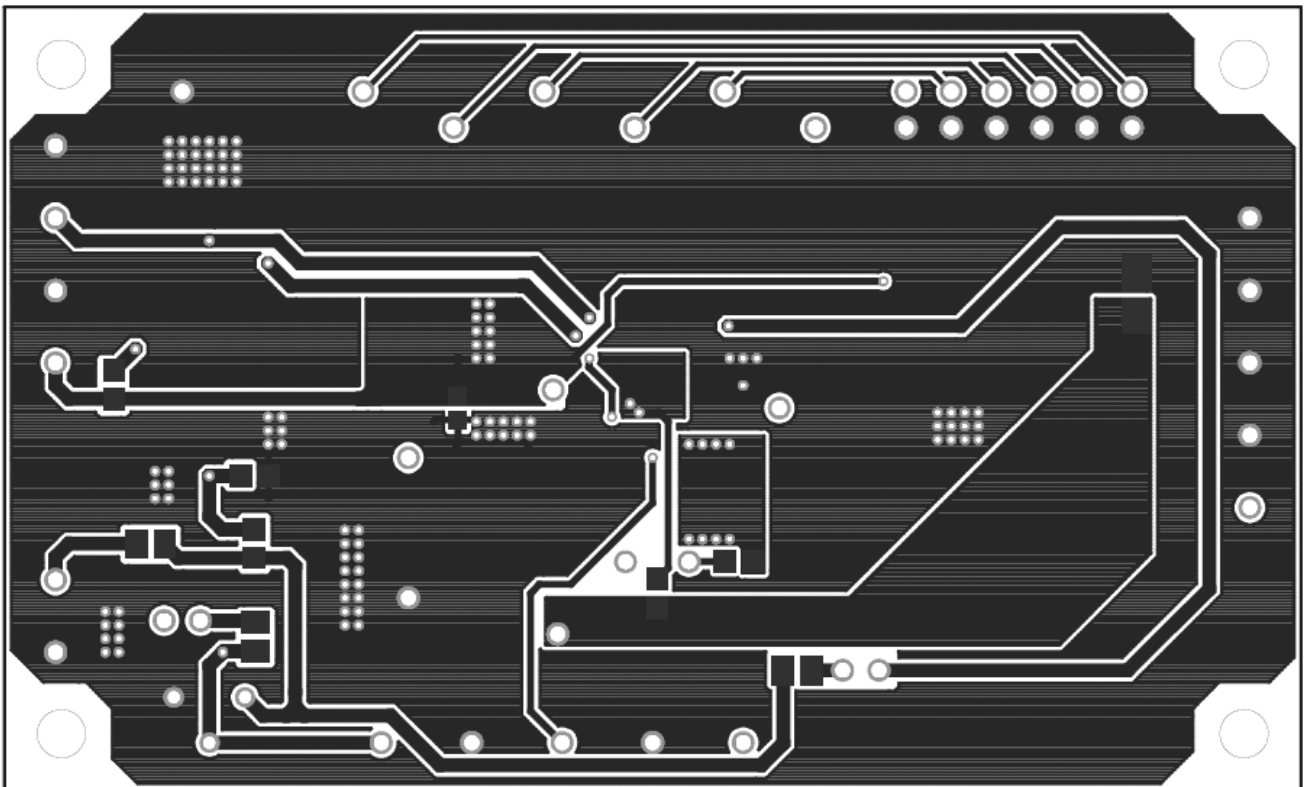

Fig.44 Rear surface <Top view>

● Selection of external parts

Recommended external parts are as shown below. When to use other parts than these, select the following equivalent parts.

• Coil

Value	Manufacturer	Product number	Size			DC current (mA)	DCR (Ω)
			Vertical	Horizontal	Height (MAX)		
4.7μH	TOKO	A915AY-4R7M	5.2	5.2	3.0	1870	0.045
4.7μH	TOKO	B1015AS-4R7M	8.4	8.3	4.0	3300	0.038
4.7μH	TOKO	A1101AS-4R7M	4.1	4.1	1.2	1400	0.115
4.7μH	TDK	LTF5022T-4R7N2R0	5.0	5.2	2.2	2000	0.073
4.7μH	TDK	VLP6810T-4R7M1R6	6.3	6.8	1.0	1600	0.167
10μH	TDK	VLP6810T-100M1R1	6.3	6.8	1.0	1100	0.350

• Capacitor

Value	Pressure	Manufacturer	Product number	Size			TC	Cap Tolerance
				Vertical	Horizontal	Height		
[Supply voltage capacitor]								
10μF	25V	MURATA	GRM31CB31E106K	3.2	1.6	1.6±0.2	B	+/-10%
10μF	10V	MURATA	GRM219BB31A106K	2.0	1.25	0.85±0.15	B	+/-10%
4.7μF	25V	MURATA	GRM319B31E475K	3.2	1.6	0.85±0.1	B	+/-10%
4.7μF	25V	MURATA	GRM21BB31E475K	2.0	1.25	1.25±0.1	B	+/-10%
[Smoothing capacitor for built-in regulator]								
1μF	10V	MURATA	GRM188B10J105K	1.6	0.8	0.8±0.1	B	+/-10%
2.2μF	10V	MURATA	GRM219B11A225K	2.0	1.25	0.85±0.1	B	+/-10%
[Output capacitor]								
1μF	50V	MURATA	GRM31MB31H105K	3.2	1.6	1.15±0.1	B	+/-10%
1μF	50V	MURATA	GRM21BB31H105K	2.0	1.25	1.25±0.1	B	+/-10%
1μF	100V	MURATA	GRM31CR72A105K	3.2	1.6	1.6±0.2	X7R	+/-10%
2.2μF	50V	MURATA	GRM31CB31H225K	3.2	1.6	1.6±0.2	B	+/-10%
0.33μF	50V	MURATA	GRM219B31H334K	2.0	1.25	0.85±0.1	B	+/-10%

• Resistor

Value	Tolerance	Manufacturer	Product number	Size		
				Vertical	Horizontal	Height
[Resistor for LED current decision <ISETH pin>]						
16kΩ	±0.5%	ROHM	MCR006YZPD163	0.6	0.3	0.23±0.03
[Resistor for over current decision <SENSP pin>]						
47mΩ	±1%	ROHM	MCR10EZHF047	2.0	1.25	0.55±0.1

• SBD

Pressure	Manufacturer	Product number	Size		
			Vertical	Horizontal	Height
60V	ROHM	RB160M-60	3.5	1.6	0.8±0.1

• MOS FET Nch

Pressure	Manufacturer	Product number	Size			Current ability	Driving voltage
			Vertical	Horizontal	Height		
45V	ROHM	RTR020N05	2.8	2.9	1.0	2A	2.5V
60V	ROHM	RSS065N06	6.0	5.0	1.75	6.5A	4.0V

The coil is the part that is most influential to efficiency. Select the coil whose direct current resistor (DCR) and current - inductance characteristic is excellent. BD6592MUV is designed for the inductance value of 4.7μH.

Don't use the inductance value less than 2.2μH. Select a capacitor of ceramic type with excellent frequency and temperature characteristics. Further, select Capacitor to be used with small direct current resistance, and pay sufficient attention to the PCB layout shown in P.16.

● About heat loss

In heat design, operate the DC/DC converter in the following condition.

(The following temperature is a guarantee temperature, so consider the margin.)

1. Periphery temperature Ta must be less than 85°C.
2. The loss of IC must be less than dissipation Pd.

●Application example

- LED current setting controlled ISETH resistor.
 24kΩ : 20mA
 16kΩ : 30mA
 12kΩ : 40mA
- Brightness control
 Please input PWM pulse from PWMPW or PWMDRV terminal.
 Please refer electrical characteristic p.3 and function (p.12).

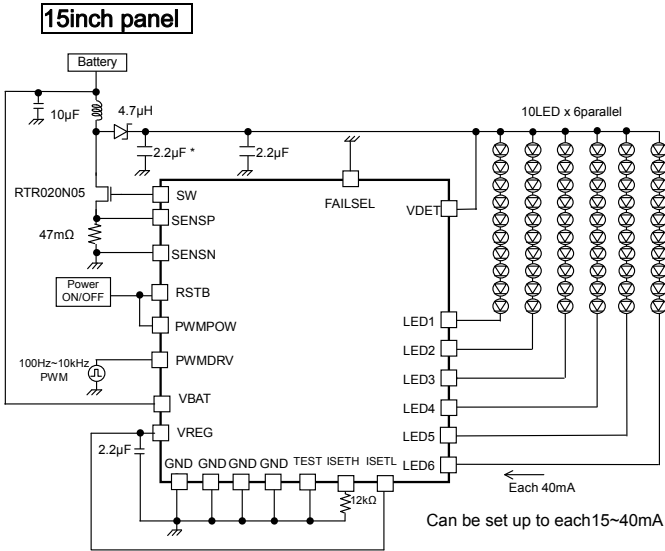

Fig.45 10 series×6 parallel, LED current 40mA setting
 Current driver PWM application

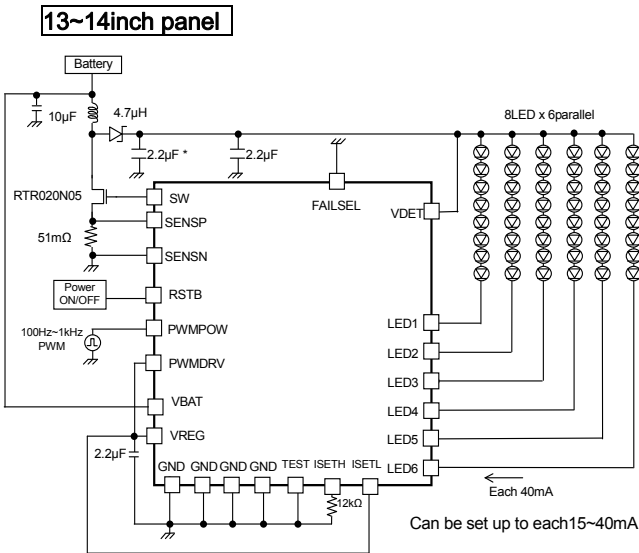

Fig.46 8 series× 6 parallel, LED current 40mA setting
 Power control PWM application

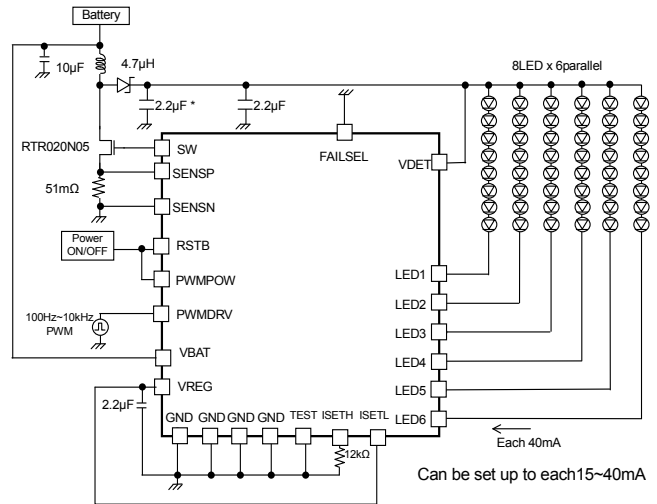

Fig.47 8 series×6 parallel, LED current 40mA setting
 Current driver PWM application

●Application example

- LED current setting controlled ISETH resistor.
 24kΩ : 20mA
 16kΩ : 30mA
 12kΩ : 40mA
- Brightness control
 Please input PWM pulse from PWMPOW or PWMDRV terminal.
 Please refer electrical characteristic p.3 and function (p.13).

10~12inch panel

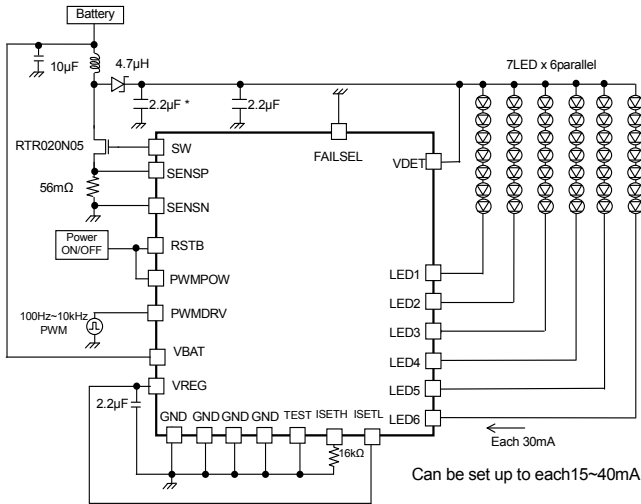

Fig.48 7 series×6 parallel, LED current 30mA setting
Current driver PWM application

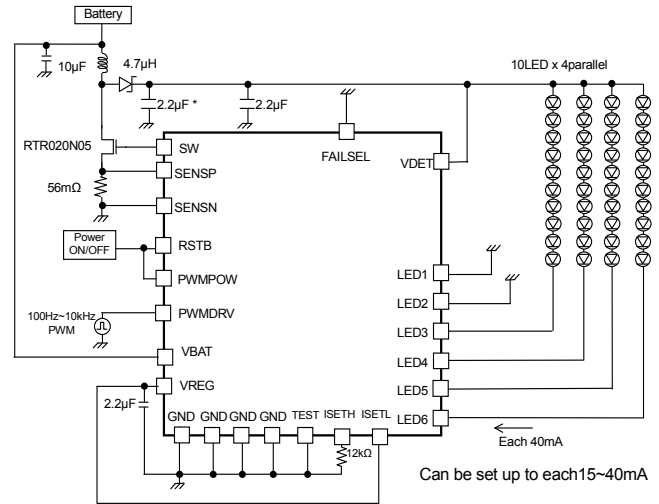

Fig.49 10 series×4 parallel, LED current 40mA setting
Current driver PWM application

7inch panel

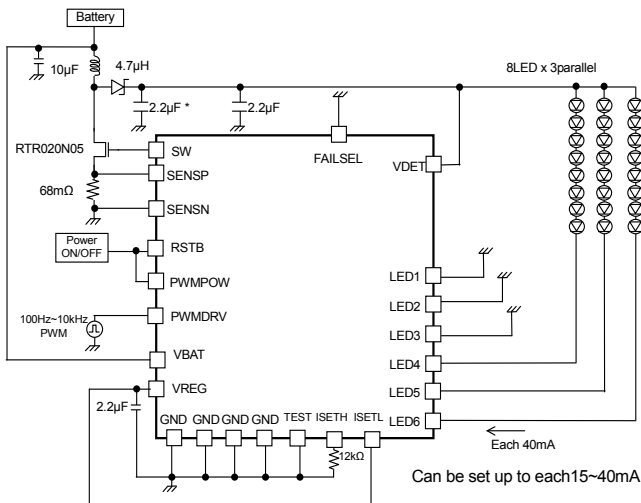

Fig.50 8 series×3 parallel, LED current 40mA setting
Current driver PWM application

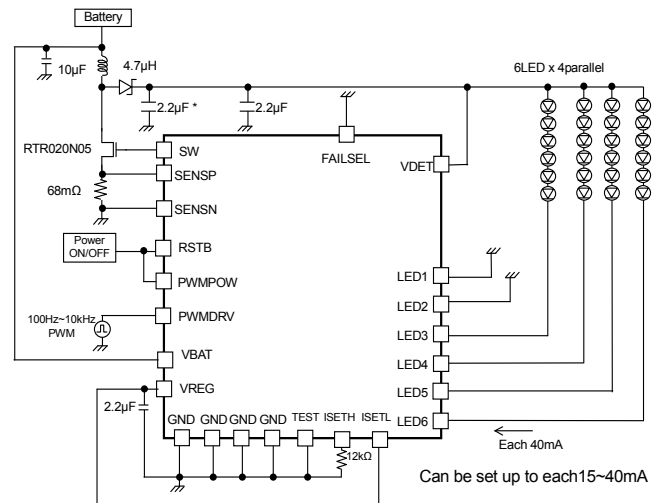

Fig.51 6 series×4 parallel, LED current 40mA setting
Current driver PWM application

●Application example

- LED current setting controlled ISETH resistor.
 24kΩ : 20mA
 16kΩ : 30mA
 12kΩ : 40mA
- Brightness control
 Please input PWM pulse from PWMPW or PWMDRV terminal.
 Please refer electrical characteristic p.3 and function (p.13).

7inch panel

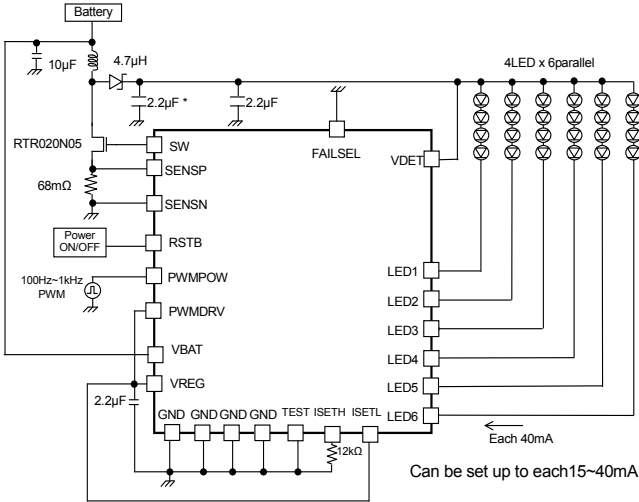

Fig.52 4 series×6 parallel, LED current 40mA setting
Power control PWM application

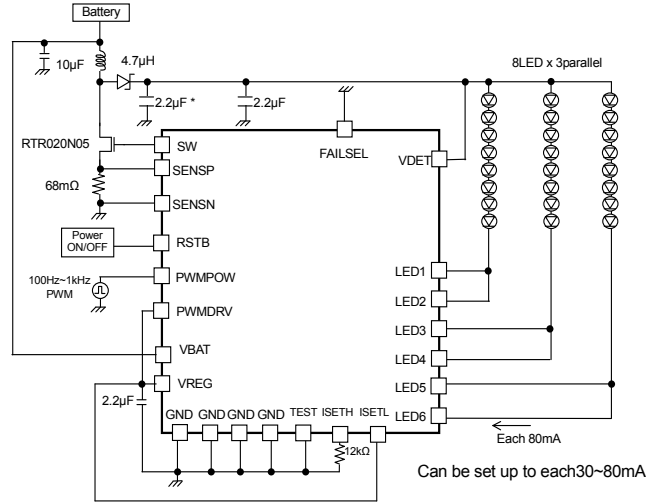

Fig.53 8 series×3 parallel, LED current 80mA setting
Power control PWM application

5inch panel

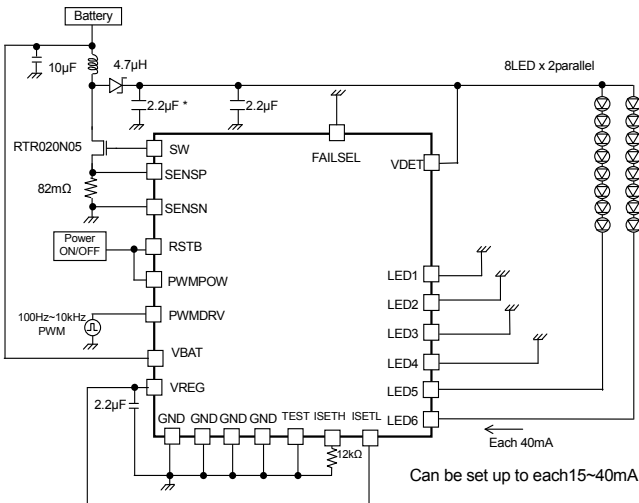

Fig.54 8 series×2 parallel, LED current 40mA setting
Current driver PWM application

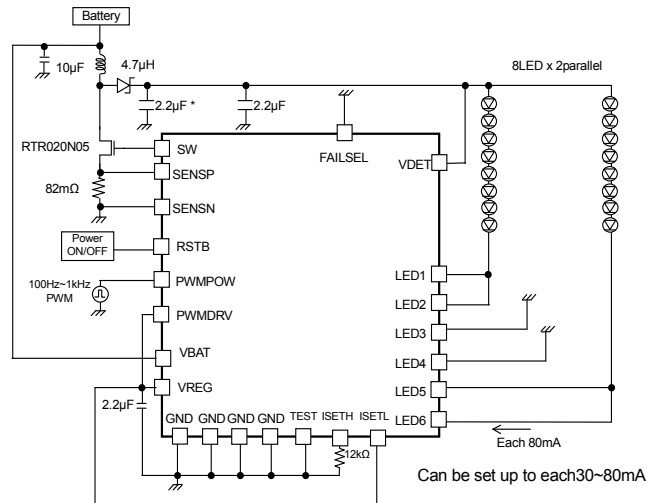

Fig.55 8 series×2 parallel, LED current 80mA setting
Power control PWM application

●Application example

- LED current setting controlled ISETH resistor.
 24kΩ : 20mA
 16kΩ : 30mA
 12kΩ : 40mA
- Brightness control
 Please input PWM pulse from PWMPW or PWMDRV terminal.
 Please refer electrical characteristic p.3 and function (p.13).

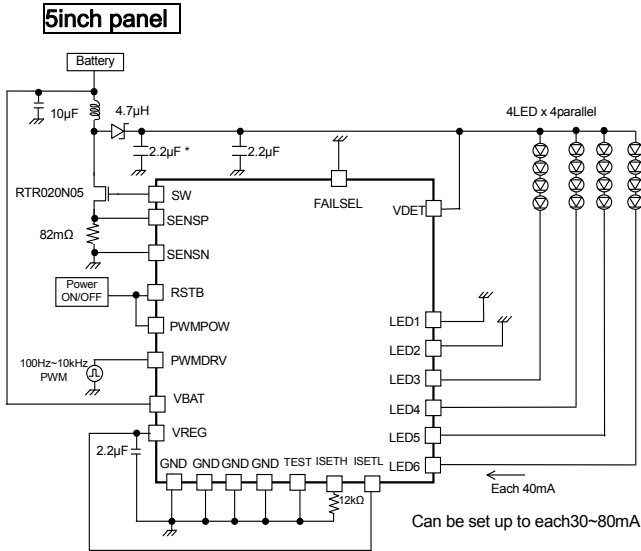

Fig.56 4 series×4 parallel, LED current 40mA setting
Current driver PWM application

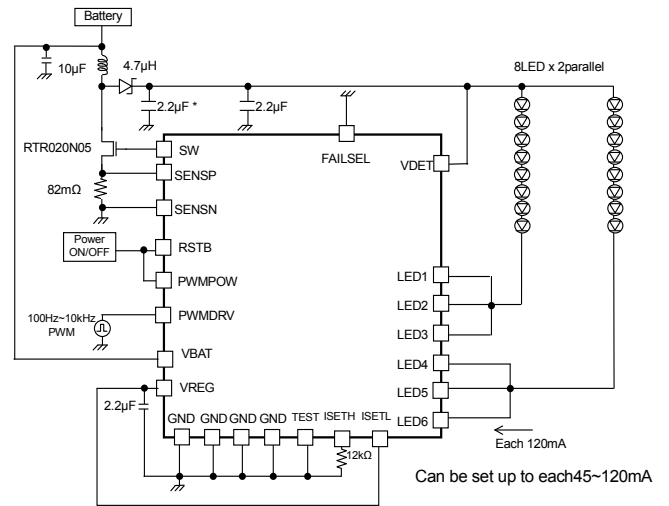

Fig.57 8 series×2 parallel, LED current 120mA setting
Current driver PWM application

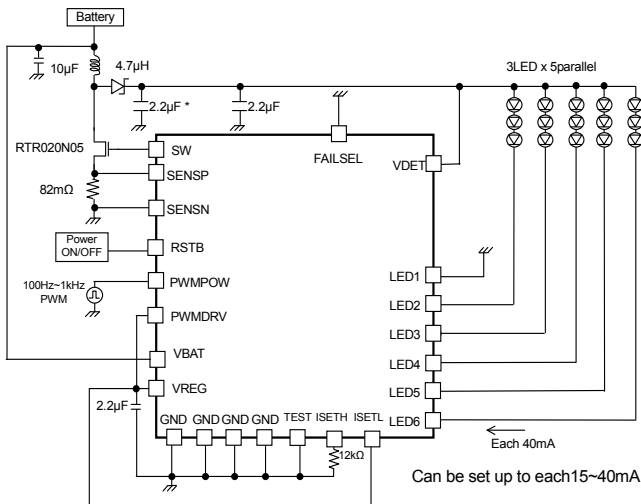

Fig.58 3 series×5 parallel, LED current 40mA setting
Power control PWM application

●Application example

- LED current setting controlled ISETH resistor.
 24kΩ : 20mA
 16kΩ : 30mA
 12kΩ : 40mA
- Brightness control
 Please input PWM pulse from PWMPW or PWMDRV terminal.
 Please refer electrical characteristic p.3 and function (p.13).

Over 22V application

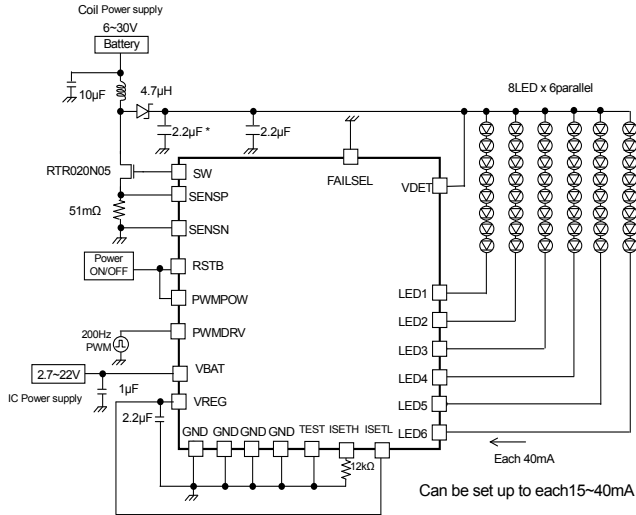

Fig.59

For Big LED Current

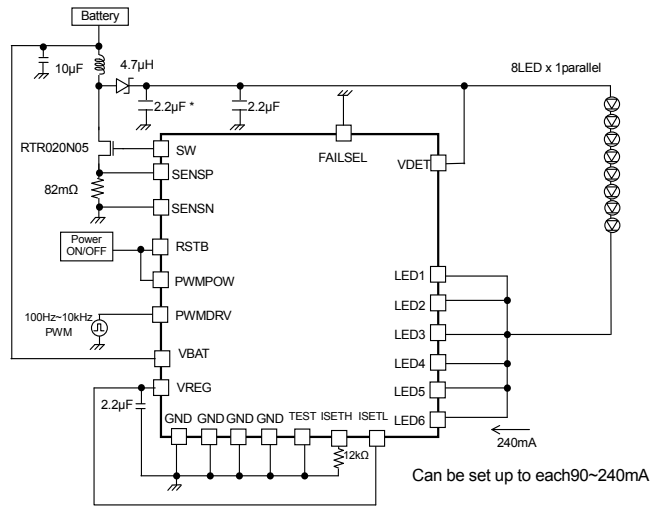

Fig.60

The separation of less than an IC power supply 5V and the coil power supply

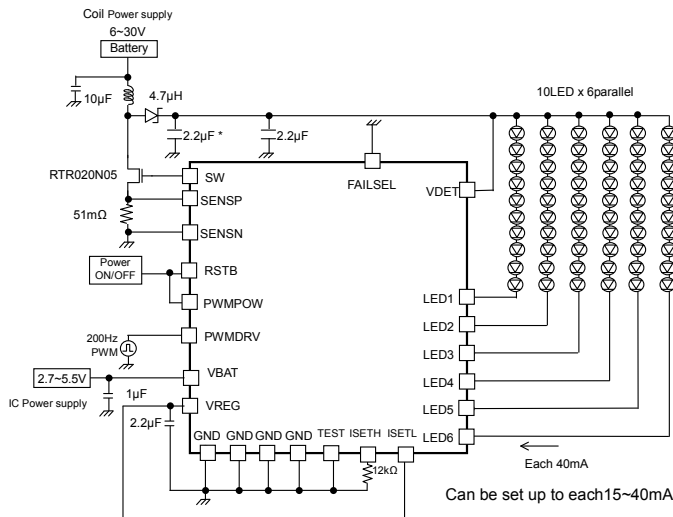
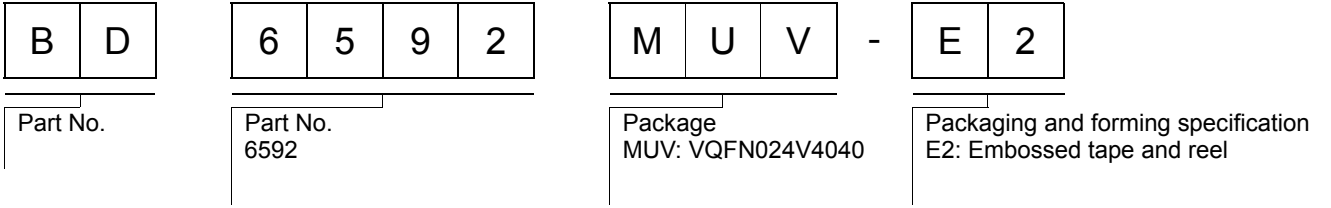

Fig.61

●Notes for use

- (1) Absolute Maximum Ratings
An excess in the absolute maximum ratings, such as supply voltage, temperature range of operating conditions, etc., can break down devices, thus making impossible to identify breaking mode such as a short circuit or an open circuit. If any special mode exceeding the absolute maximum ratings is assumed, consideration should be given to take physical safety measures including the use of fuses, etc.
- (2) Operating conditions
These conditions represent a range within which characteristics can be provided approximately as expected. The electrical characteristics are guaranteed under the conditions of each parameter.
- (3) Reverse connection of power supply connector
The reverse connection of power supply connector can break down ICs. Take protective measures against the breakdown due to the reverse connection, such as mounting an external diode between the power supply and the IC's power supply terminal.
- (4) Power supply line
Design PCB pattern to provide low impedance for the wiring between the power supply and the GND lines. In this regard, for the digital block power supply and the analog block power supply, even though these power supplies has the same level of potential, separate the power supply pattern for the digital block from that for the analog block, thus suppressing the diffraction of digital noises to the analog block power supply resulting from impedance common to the wiring patterns. For the GND line, give consideration to design the patterns in a similar manner.
Furthermore, for all power supply terminals to ICs, mount a capacitor between the power supply and the GND terminal. At the same time, in order to use an electrolytic capacitor, thoroughly check to be sure the characteristics of the capacitor to be used present no problem including the occurrence of capacity dropout at a low temperature, thus determining the constant.
- (5) GND voltage
Make setting of the potential of the GND terminal so that it will be maintained at the minimum in any operating state. Furthermore, check to be sure no terminals are at a potential lower than the GND voltage including an actual electric transient.
- (6) Short circuit between terminals and erroneous mounting
In order to mount ICs on a set PCB, pay thorough attention to the direction and offset of the ICs. Erroneous mounting can break down the ICs. Furthermore, if a short circuit occurs due to foreign matters entering between terminals or between the terminal and the power supply or the GND terminal, the ICs can break down.
- (7) Operation in strong electromagnetic field
Be noted that using ICs in the strong electromagnetic field can malfunction them.
- (8) Inspection with set PCB
On the inspection with the set PCB, if a capacitor is connected to a low-impedance IC terminal, the IC can suffer stress. Therefore, be sure to discharge from the set PCB by each process. Furthermore, in order to mount or dismount the set PCB to/from the jig for the inspection process, be sure to turn OFF the power supply and then mount the set PCB to the jig. After the completion of the inspection, be sure to turn OFF the power supply and then dismount it from the jig. In addition, for protection against static electricity, establish a ground for the assembly process and pay thorough attention to the transportation and the storage of the set PCB.
- (9) Input terminals
In terms of the construction of IC, parasitic elements are inevitably formed in relation to potential. The operation of the parasitic element can cause interference with circuit operation, thus resulting in a malfunction and then breakdown of the input terminal. Therefore, pay thorough attention not to handle the input terminals, such as to apply to the input terminals a voltage lower than the GND respectively, so that any parasitic element will operate. Furthermore, do not apply a voltage to the input terminals when no power supply voltage is applied to the IC. In addition, even if the power supply voltage is applied, apply to the input terminals a voltage lower than the power supply voltage or within the guaranteed value of electrical characteristics.
- (10) Ground wiring pattern
If small-signal GND and large-current GND are provided, It will be recommended to separate the large-current GND pattern from the small-signal GND pattern and establish a single ground at the reference point of the set PCB so that resistance to the wiring pattern and voltage fluctuations due to a large current will cause no fluctuations in voltages of the small-signal GND. Pay attention not to cause fluctuations in the GND wiring pattern of external parts as well.
- (11) External capacitor
In order to use a ceramic capacitor as the external capacitor, determine the constant with consideration given to a degradation in the nominal capacitance due to DC bias and changes in the capacitance due to temperature, etc.
- (12) Thermal shutdown circuit (TSD)
When junction temperatures become 175°C (typ) or higher, the thermal shutdown circuit operates and turns a switch OFF. The thermal shutdown circuit, which is aimed at isolating the LSI from thermal runaway as much as possible, is not aimed at the protection or guarantee of the LSI. Therefore, do not continuously use the LSI with this circuit operating or use the LSI assuming its operation.
- (13) Thermal design
Perform thermal design in which there are adequate margins by taking into account the permissible dissipation (Pd) in actual states of use.
- (14) Selection of coil
Select the low DCR inductors to decrease power loss for DC/DC converter.

●Ordering part number



VQFN024V4040

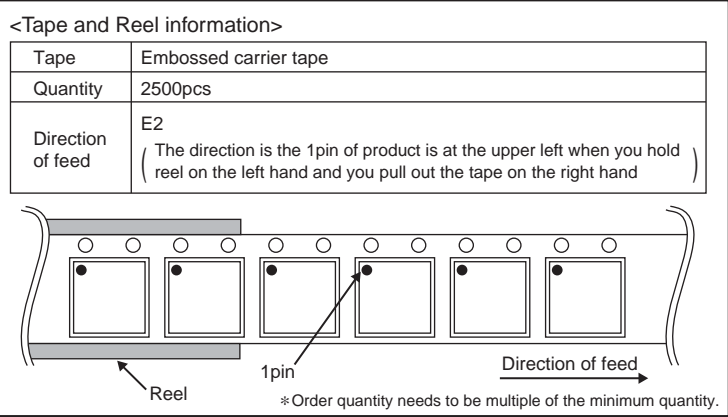
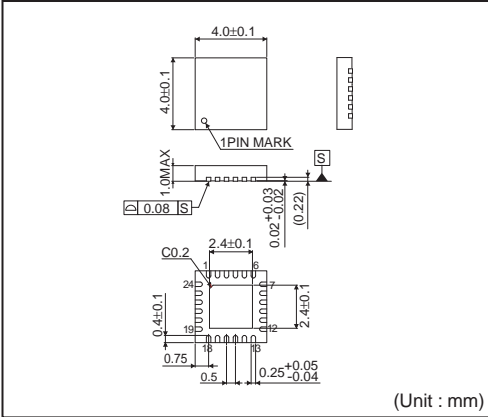

Notes

No copying or reproduction of this document, in part or in whole, is permitted without the consent of ROHM Co.,Ltd.

The content specified herein is subject to change for improvement without notice.

The content specified herein is for the purpose of introducing ROHM's products (hereinafter "Products"). If you wish to use any such Product, please be sure to refer to the specifications, which can be obtained from ROHM upon request.

Examples of application circuits, circuit constants and any other information contained herein illustrate the standard usage and operations of the Products. The peripheral conditions must be taken into account when designing circuits for mass production.

Great care was taken in ensuring the accuracy of the information specified in this document. However, should you incur any damage arising from any inaccuracy or misprint of such information, ROHM shall bear no responsibility for such damage.

The technical information specified herein is intended only to show the typical functions of and examples of application circuits for the Products. ROHM does not grant you, explicitly or implicitly, any license to use or exercise intellectual property or other rights held by ROHM and other parties. ROHM shall bear no responsibility whatsoever for any dispute arising from the use of such technical information.

The Products specified in this document are intended to be used with general-use electronic equipment or devices (such as audio visual equipment, office-automation equipment, communication devices, electronic appliances and amusement devices).

The Products specified in this document are not designed to be radiation tolerant.

While ROHM always makes efforts to enhance the quality and reliability of its Products, a Product may fail or malfunction for a variety of reasons.

Please be sure to implement in your equipment using the Products safety measures to guard against the possibility of physical injury, fire or any other damage caused in the event of the failure of any Product, such as derating, redundancy, fire control and fail-safe designs. ROHM shall bear no responsibility whatsoever for your use of any Product outside of the prescribed scope or not in accordance with the instruction manual.

The Products are not designed or manufactured to be used with any equipment, device or system which requires an extremely high level of reliability the failure or malfunction of which may result in a direct threat to human life or create a risk of human injury (such as a medical instrument, transportation equipment, aerospace machinery, nuclear-reactor controller, fuel-controller or other safety device). ROHM shall bear no responsibility in any way for use of any of the Products for the above special purposes. If a Product is intended to be used for any such special purpose, please contact a ROHM sales representative before purchasing.

If you intend to export or ship overseas any Product or technology specified herein that may be controlled under the Foreign Exchange and the Foreign Trade Law, you will be required to obtain a license or permit under the Law.



Thank you for your accessing to ROHM product informations.
More detail product informations and catalogs are available, please contact us.



ROHM Customer Support System

<http://www.rohm.com/contact/>



Looking for pricing, stock, or lifecycle information?

Click below to explore more details on WIN SOURCE:

-  [View BD6592MUV-E2 on WIN SOURCE](#)
-  [Rohm Semiconductor](#) Information

Optimize Your Supply Chain with WIN SOURCE Solutions

-  Global Sourcing Solution
-  Obsolete Management
-  Cost Control Management
-  Shortage Management
-  Alternative Solution
-  Excess Inventory Management