



**THE DATASHEET OF
TPS65281RGVR**



PRECISION ADJUSTABLE CURRENT LIMITED POWER DISTRIBUTION SWITCH WITH 4.5V TO 18V INPUT VOLTAGE, 3A OUTPUT CURRENT SYNCHRONOUS BUCK REGULATOR

Check for Samples: [TPS65281](#), [TPS65281-1](#)

FEATURES

INTEGRATED POWER DISTRIBUTION SWITCH

- Operating Input Voltage Range: 2.5 V to 6.5 V
- Adjustable Current Limit:
75 mA - 2.7 A (typical)
- $\pm 6\%$ Current-Limit Accuracy at 1.7 A (typical)
- Over Current Latch-Off Protection (TPS65281) and Over Current Auto-Recovery (TPS65281-1)
- Reverse Input-Output Voltage Protection
- Built-In Soft-Start
- Integrated Back-to-Back Power MOSFETs With 100-m Ω On-Resistance
- Over Temperature Protection

INTEGRATED BUCK CONVERTER

- Wide Input Voltage Range: 4.5 V to 18 V
- Maximum Continuous 3-A Output Current
- Feedback Reference Voltage: 0.8 V $\pm 1\%$
- Adjustable 300-kHz to 1.4-MHz Switching Frequency
- Adjustable Soft Start and Tracking With Built-In 1-ms Internal Soft-Start Time
- Cycle-by-Cycle Current Limit
- Output Over-voltage Protection
- 16-Lead QFN (RGV) 4-mm x 4-mm Package

APPLICATIONS

- USB Ports and Hubs
- Digital TV
- Set-Top Boxes
- VOIP Phones
- Tablet PC

DESCRIPTION/ORDERING INFORMATION

The TPS65281/TPS65281-1 incorporates an N-channel back-to-back power MOSFET switch and a monolithic buck converter. The device is intended to provide a total power distribution solution for digital TV, set-top boxes, tablet PC and VOIP phones etc applications, where precision current limiting is required or heavy capacitive load or short circuit are encountered.

A 100-m Ω independent power distribution switch limits the output current to a programmable current limit threshold between typical 75 mA and 2.7 A by using an external resistor. The current limit accuracy as tight as $\pm 6\%$ can be achieved at higher current limit setting. TPS65281 provides circuit breaker functionality by latching off the power switch during over-current or reverse-voltage situations. TPS65281-1 limits output current to a safe level by using a constant current mode when the output load exceeds the current limit threshold. An internal reverse-voltage comparator disables the power switch when the output voltage is driven higher than the input to protect the device on the input side of the switch in normal operation. The nFAULT output asserts low under over-current and reverse-voltage conditions. Back-to-back power MOSFETs structure prevents the reverse current injection from an active load at output port during shutdown of power switch.



Please be aware that an important notice concerning availability, standard warranty, and use in critical applications of Texas Instruments semiconductor products and disclaimers thereto appears at the end of this data sheet.

The buck DC/DC converter integrates power MOSFETs for optimized power efficiency and reduced external component count. A wide 4.5-V to 18-V input supply range to buck encompasses most intermediate bus voltages operating off 5-V, 9-V, 12-V or 15-V power bus. Constant frequency peak current mode control simplifies the compensation and provides fast transient response. The buck can be precisely sequenced and ramp up in order to align with other rails in the system with the soft-start pin. With SS pin floating, the built-in 1ms soft-start time prevents in-rush current. Cycle-by-cycle over current protection and hiccup operation limit MOSFET power dissipation in short circuit or over loading fault conditions. The switching frequency of the converter can be programmed from 300 kHz to 1.4 MHz with an external resistor at ROsc pin. With ROsc pin connecting to V7V pin, floating, or grounding, a default fixed switching frequency can be selected to reduce an external resistor.

The TPS65281/TPS65281-1 is available in a 16-lead thermally enhanced QFN (RGV) 4-mm x 4-mm thin package.

ORDERING INFORMATION⁽¹⁾

T _A	PACKAGE ⁽²⁾	ORDERABLE PART NUMBER	TOP-SIDE MARKING
-40°C to 85°C	16-Pin QFN (RGV)	TPS65281RGVR	TPS65281
		TPS65281RGVT	
		TPS65281-1RGVR	TPS65281-1
		TPS65281-1RGVT	

(1) For the most current package and ordering information, see the Package Option Addendum at the end of this document, or see the TI web site at www.ti.com.

(2) Package drawings, thermal data, and symbolization are available at www.ti.com/packaging.



This integrated circuit can be damaged by ESD. Texas Instruments recommends that all integrated circuits be handled with appropriate precautions. Failure to observe proper handling and installation procedures can cause damage.

ESD damage can range from subtle performance degradation to complete device failure. Precision integrated circuits may be more susceptible to damage because very small parametric changes could cause the device not to meet its published specifications.

TYPICAL APPLICATION

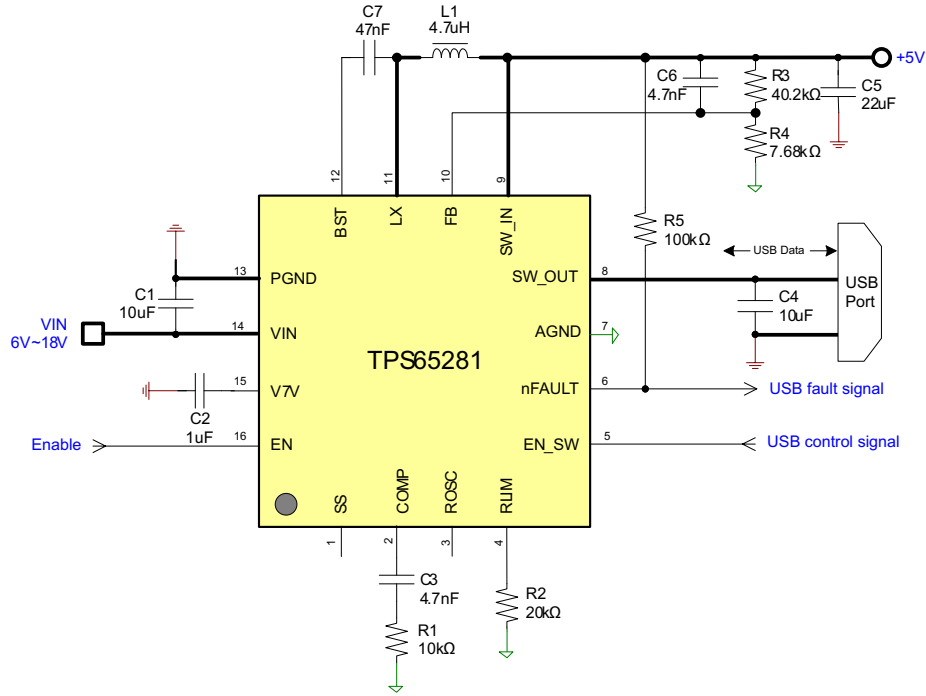

Figure 1. 12-V Power Bus

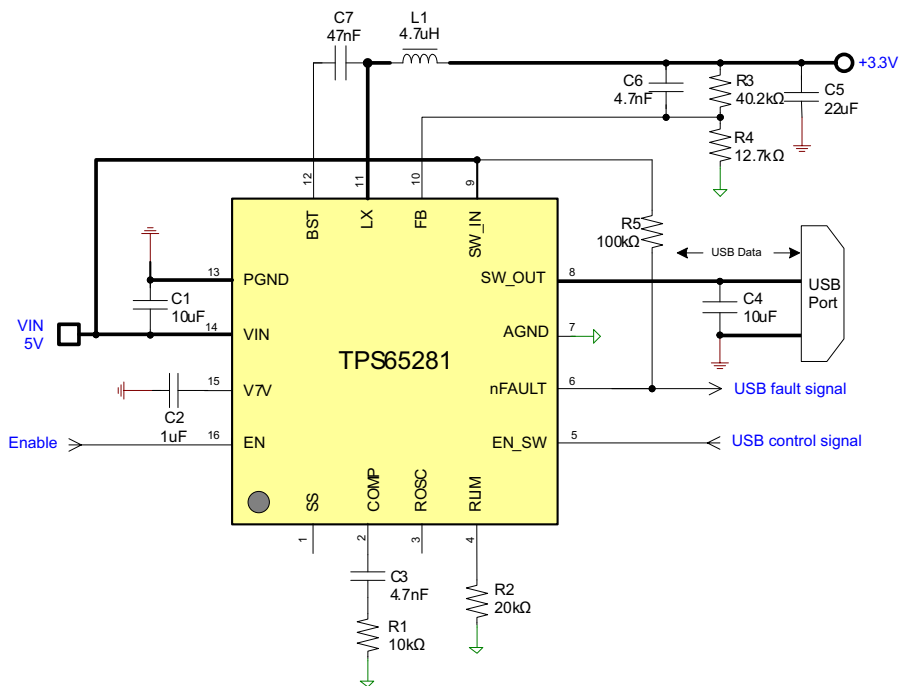
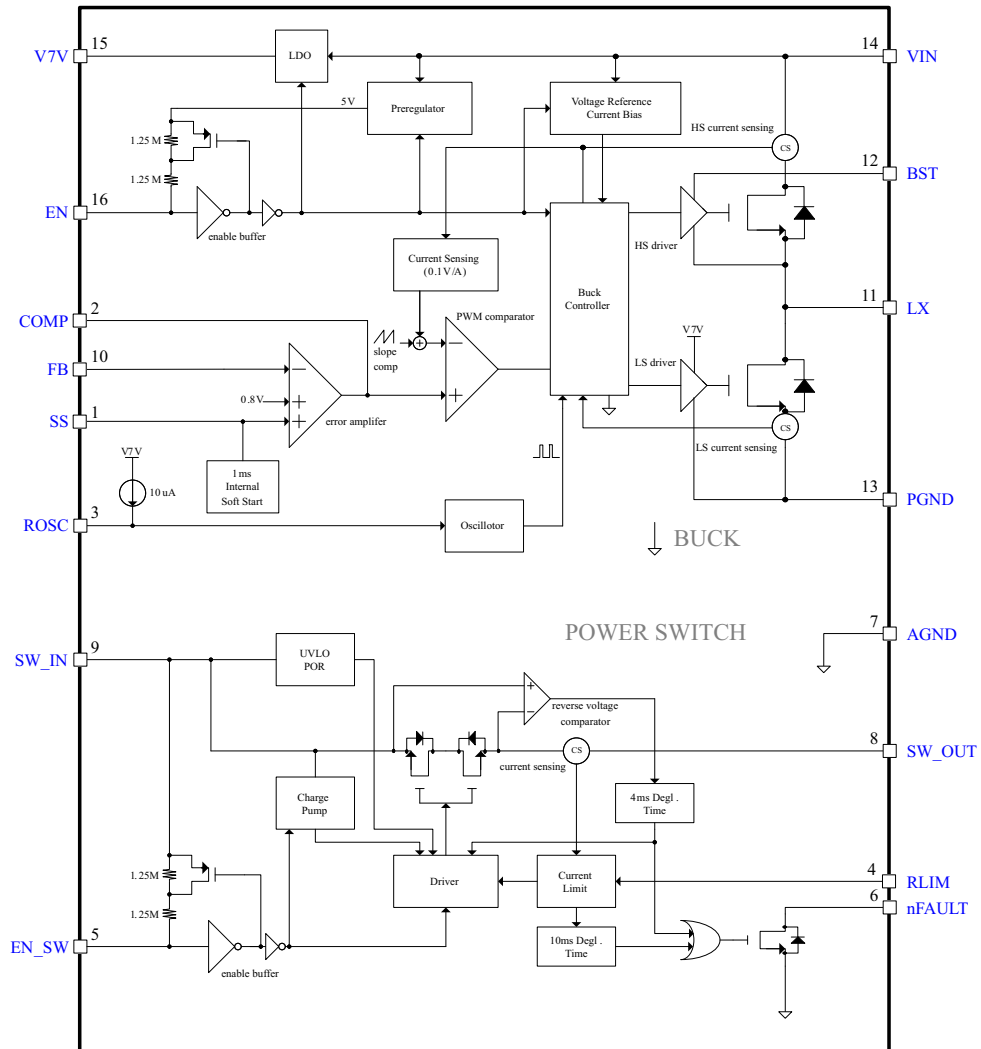

Figure 2. 5-V Power Bus

FUNCTION BLOCK DIAGRAM



PIN OUT

**RGV PACKAGE
(TOP VIEW)**

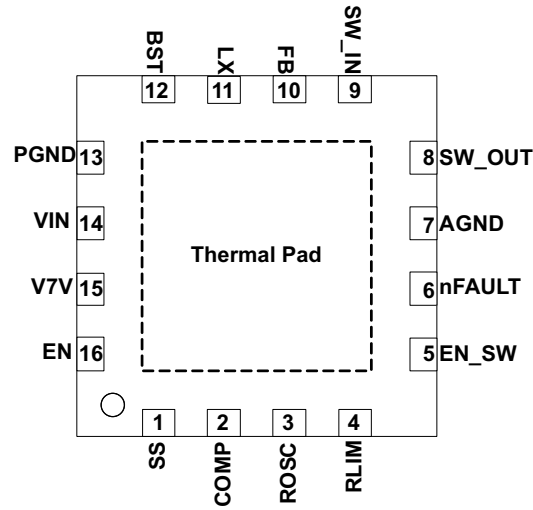

Exposed thermal pad must be soldered to PCB for optimal thermal performance.

TERMINAL FUNCTIONS

NAME	NO.	DESCRIPTION
SS	1	Soft-start and tracking input for buck converter. An internal 5- μ A current source is connected to this pin. An external soft-start can be programmed by connecting a capacitor between this pin and ground. Leave the pin floating to have a default 1-ms of soft-start time. This pin allows the start-up of buck output to track an external voltage using an external resistor divider at this pin.
COMP	2	Error amplifier output and Loop compensation pin for buck. Connect a series RC to compensate the control loop of buck converter.
ROSC	3	Oscillator clock frequency control pin. Connect the pin to ground for a fixed 300-kHz switching frequency. Connect the pin to V7V or float the pin for a fixed 600-kHz switching frequency. Other switch frequencies between 300 kHz to 1.4 MHz can be programmed using a resistor connected from this pin to ground. A internal 10- μ A pull-up current develops a voltage to be used in oscillator. Directly applying the voltage to the ROSC pin can linearly adjust the switching frequency.
RLIM	4	Power switch current limit control pin. An external resistor used to set current limit threshold of power switch. Recommended $15\text{ k}\Omega \leq \text{RLIM} \leq 232\text{ k}\Omega$.
EN_SW	5	Enable pin of power switch. Logic high turns on power switch. Forcing the pin below 0.4 V shuts down power switch. Not recommend floating this pin, though there is a 2.5-M Ω pull-up resistor connecting this pin.
nFAULT	6	Active low open drain output, asserted in conditions when over-current happens for more than 10 ms or reverse-voltage of power switch for more than 4 ms.
AGND	7	Analog ground common to buck controller and power switch controller. It must be routed separately from high current power grounds to the (-) terminal of bypass capacitor of internal V7V LDO output.
SW_OUT	8	Power switch output pin
SW_IN	9	Power switch input pin
FB	10	Feedback sensing pin for buck output voltage. Connect this pin to the resistor divider of buck output. The feedback reference voltage is $0.8\text{ V} \pm 1\%$.
LX	11	Switching node connection to the internal power FETs, inductor and bootstrap capacitor for buck converter. The voltage swing at this pin is from a diode voltage below the ground up to V_{IN} voltage.
BST	12	Bootstrapped supply to the high side floating gate driver in buck converter. Connect a capacitor (recommend 47 nF) from BST pin to LX pin.
PGND	13	Power ground connection. Connect PGND pin as close as practical to the (-) terminal of input ceramic capacitor.
VIN	14	Input power supply for buck. Connect VIN pin as close as practical to the (+) terminal of a input ceramic capacitor (suggest 10 μ F).
V7V	15	Internal LDO output. The internal gate driver for low side power MOSFET and control circuits are powered from this voltage. Decouple this pin to power ground with a minimum 1- μ F ceramic capacitor. The output voltage level of LDO is regulated to typical 6.3 V for optimal conduction on-resistances of internal power MOSFETs.
EN	16	Enable for buck converter and the device. Logic high enables buck converter and bias supply to power switches. Forcing the pin below 0.4 V shuts down the entire device, reducing the quiescent current to approximate typical 7 μ A. Not recommend floating this pin. The device can be automatically started up with connecting EN pin to VIN though a 10 k Ω resistor.
Power PAD		Exposed pad beneath the IC. Connect to the ground. Always solder power pad to the board, and have as many thermal vias as possible on the PCB to enhance power dissipation. There is no ground or any other electric signal downbonded to the pad inside the IC package.

ABSOLUTE MAXIMUM RATINGS ⁽¹⁾

over operating free-air temperature range (unless otherwise noted)

V _{IN}		–0.3 to 18	V
LX (Maximum withstand voltage transient < 20ns)		–1.0 to 18	V
BST referenced to LX pin		–0.3 to 7	V
SW_IN, SW_OUT		–0.3 to 7	V
EN, EN_SW, nFAULT, V7V, ROSC, RLIM		–0.3 to 7	V
SS, COMP, FB		–0.3 to 3.6	V
AGND, PGND		–0.3 to 0.3	V
T _J	Operating virtual junction temperature range	–40 to 125	°C
T _{STG}	Storage temperature range	–55 to 150	°C

- (1) Stresses beyond those listed under "absolute maximum ratings" may cause permanent damage to the device. These are stress ratings only, and functional operation of the device at these or any other conditions beyond those indicated under "recommended operating conditions" is not implied. Exposure to absolute–maximum–rated conditions for extended periods may affect device reliability.

RECOMMENDED OPERATING CONDITIONS

over operating free-air temperature range (unless otherwise noted)

		MIN	NOM	MAX	UNIT
V _{IN}	Input operating voltage	4.5		18	V
T _A	Ambient temperature	–40		85	°C

ELECTROSTATIC DISCHARGE (ESD) PROTECTION ⁽¹⁾

	MIN	MAX	UNIT
Human body model (HBM)	4000		V
Charge device model (CDM)	500		V
Machine model (MM)	200		V

- (1) SW_OUT pin human body model (HBM) ESD protection rating 4 kV, and machine model (MM) rating 200V.

THERMAL INFORMATION

THERMAL METRIC ⁽¹⁾	TPS65281/TPS65281-1		UNITS
	RGV		
	16 PINS		
θ_{JA}	Junction-to-ambient thermal resistance ⁽²⁾	36.5	°C/W
θ_{JcTop}	Junction-to-case (top) thermal resistance ⁽³⁾	42.7	
θ_{JB}	Junction-to-board thermal resistance ⁽⁴⁾	14.7	
ψ_{JT}	Junction-to-top characterization parameter ⁽⁵⁾	0.5	
ψ_{JB}	Junction-to-board characterization parameter ⁽⁶⁾	14.8	
θ_{JcBot}	Junction-to-case (bottom) thermal resistance ⁽⁷⁾	3.3	

- (1) For more information about traditional and new thermal metrics, see the *IC Package Thermal Metrics* application report, [SPRA953](#).
 (2) The junction-to-ambient thermal resistance under natural convection is obtained in a simulation on a JEDEC-standard, high-K board, as specified in JESD51-7, in an environment described in JESD51-2a.
 (3) The junction-to-case (top) thermal resistance is obtained by simulating a cold plate test on the package top. No specific JEDEC-standard test exists, but a close description can be found in the ANSI SEMI standard G30-88.
 (4) The junction-to-board thermal resistance is obtained by simulating in an environment with a ring cold plate fixture to control the PCB temperature, as described in JESD51-8.
 (5) The junction-to-top characterization parameter, ψ_{JT} , estimates the junction temperature of a device in a real system and is extracted from the simulation data for obtaining θ_{JA} , using a procedure described in JESD51-2a (sections 6 and 7).
 (6) The junction-to-board characterization parameter, ψ_{JB} , estimates the junction temperature of a device in a real system and is extracted from the simulation data for obtaining θ_{JA} , using a procedure described in JESD51-2a (sections 6 and 7).
 (7) The junction-to-case (bottom) thermal resistance is obtained by simulating a cold plate test on the exposed (power) pad. No specific JEDEC standard test exists, but a close description can be found in the ANSI SEMI standard G30-88.

ELECTRICAL CHARACTERISTICS

T_J = 25°C, V_{IN} = 12 V, f_{SW} = 600 kHz, R_{nFAULT} = 100 kΩ (unless otherwise noted)

PARAMETER		TEST CONDITIONS	MIN	TYP	MAX	UNIT
INPUT SUPPLY						
V _{IN}	Input voltage range		4.5		18	V
IDDS _{SDN}	Shutdown supply current	EN = EN_SW = low		7	20	μA
IDDQ _{NSW}	Switching quiescent current with no load at DCDC output	EN = high, EN_SW = low, FB = 6 V With Buck not switching		0.8		mA
IDDQ _{SW}	Switching quiescent current with no load at DCDC output, Buck switching	EN = high, EN_SW = low, FB = 5 V With Buck switching		13		mA
UVLO	V _{IN} under voltage lockout	Rising V _{IN}	4.10	4.30	4.50	V
		Falling V _{IN}	3.85	4.10	4.35	
		Hysteresis		0.2		
V _{7V}	Internal biasing supply	V _{7V} load current = 0 A, V _{IN} = 12 V	6.17	6.32	6.47	V
OSCILLATOR						
f _{SW_BK}	Switching frequency range	Set by external resistor ROSC	300		1400	kHz
f _{SW}	Programmable frequency	ROSC = 51 kΩ		510		kHz
		ROSC = 140 kΩ		1400		
		ROSC floating or connected to V _{7V}		600		
		ROSC connected to ground		270		
BUCK CONVERTER						
V _{FB}	Feedback voltage	V _{COMP} = 1.2 V, T _J = 25°C	0.792	0.8	0.808	V
		V _{COMP} = 1.2 V, T _J = -40°C to 125°C	0.784	0.8	0.816	
V _{LINREG}	Line regulation - DC	I _{OUT} = 2 A		0.5		%/V
V _{LOADREG}	Load regulation - DC	I _{OUT} = 0.3 A - 2.7 A		0.5		%/A
G _{m_EA}	Error amplifier trans-conductance ⁽¹⁾	-2 μA < I _{COMP} < 2 μA		500		μs
G _{m_SRC}	COMP voltage to inductor current G _m ⁽¹⁾	I _{LX} = 0.5 A		20		A/V
V _{ENH}	EN high level input voltage		2			V
V _{ENL}	EN low level input voltage				0.4	V
I _{SS}	Soft-start charging current			4.7		μA
t _{SS_INT}	Internal soft-start time	SS pin open	0.5	1	1.5	ms
I _{LIMIT}	Buck peak inductor current limit			4		A
R _{dson_HS}	On resistance of high side FET in buck	V _{7V} = 6.3 V, with bond wire resistance		90		mΩ
R _{dson_LS}	On resistance of low side FET in buck	V _{IN} = 12 V, with bond wire resistance		70		mΩ
POWER DISTRIBUTION SWITCH						
V _{SW_IN}	Power switch input voltage range		2.5		6	V
V _{UVLO_SW}	Input under-voltage lock out	V _{SW_IN} rising	2.15	2.25	2.35	V
		V _{SW_IN} falling	2.08	2.13	2.28	V
		Hysteresis		120		mV
R _{DSON_SW}	Power switch NDMOS on-resistance	V _{SW_IN} = 5 V, I _{SW_OUT} = 0.5 A, including bond wire resistance		100		mΩ
		V _{SW_IN} = 2.5 V, I _{SW_OUT} = 0.5 A, includes bond wire resistance		100		
t _{D_on}	Turn-on delay time from EN_SW turns high			1.4	2	ms
t _{D_off}	Turn-off delay time from EN_SW turns low			1.2	2	ms
t _r	Output rise time	V _{SW_IN} = 5 V, C _L = 22 μF, R _L = 100 Ω (see Figure 3)		1.3	1.5	ms
t _f	Output fall time			5	10	ms
I _{OS}	Current limit threshold (maximum DC current delivered to load) and short circuit current, SW_OUT connect to ground	R _{LIM} = 14.3 kΩ	1.65	1.76	1.87	A
		R _{LIM} = 20 kΩ	1.18	1.26	1.34	
		R _{LIM} = 50 kΩ	0.47	0.5	0.53	
		RLIM shorted to SW_IN or open	1.12	1.2	1.28	
t _{IOS}	Response time to short circuit	V _{SW_IN} = 5 V		2		us

(1) Specified by design.

ELECTRICAL CHARACTERISTICS (continued)

$T_J = 25^\circ\text{C}$, $V_{IN} = 12\text{ V}$, $f_{SW} = 600\text{ kHz}$, $R_{nFAULT} = 100\text{ k}\Omega$ (unless otherwise noted)

PARAMETER		TEST CONDITIONS	MIN	TYP	MAX	UNIT
$t_{DEGLITCH(OCF)}$	Switch over current fault deglitch	Fault assertion or de-assertion due to over-current condition	7	10	13	ms
V_{L_nFAULT}	nFAULT pin output low voltage	$I_{nFAULT} = 1\text{ mA}$		80		mV
V_{EN_SWH}	EN_SW high level input voltage	EN_SW high level input voltage	2			V
V_{EN_SWL}	EN_SW high level input voltage	EN_SW low level input voltage			0.4	V
R_{DIS}	Discharge resistance	$V_{SW_IN} = 5\text{ V}$, EN_SW = 0 V		100		Ω
THERMAL SHUTDOWN						
T_{TRIP_BUCK}	Thermal protection trip point	Rising temperature		160		$^\circ\text{C}$
T_{HYST_BUCK}	Thermal protection hysteresis			20		$^\circ\text{C}$
T_{TRIP_SW}	Power switch thermal protection trip point in current limit (TPS65281-1 only)	Rising temperature		145		$^\circ\text{C}$
T_{HYST_SW}		Hysteresis		10		$^\circ\text{C}$

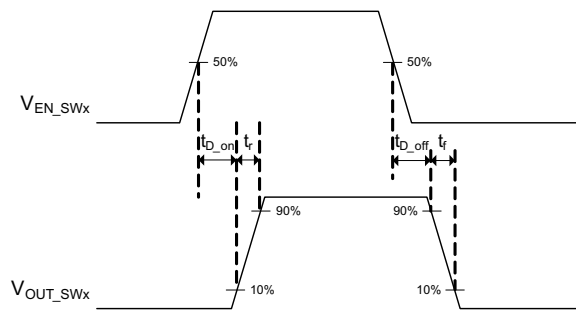

Figure 3. Power Switches Test Circuit and Voltage Waveforms

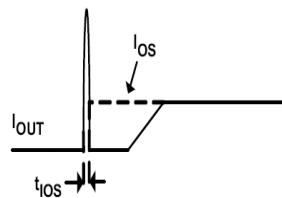

Figure 4. Response Time to Short Circuit Waveform

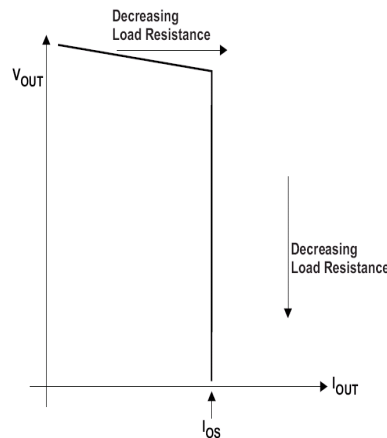

Figure 5. Output Voltage vs Current Limit Threshold

TYPICAL CHARACTERISTICS

$T_J = 25^\circ\text{C}$, $V_{IN} = 12\text{ V}$, $f_{SW} = 600\text{ kHz}$, $R_{nFAULT} = 100\text{ k}\Omega$ (unless otherwise noted)

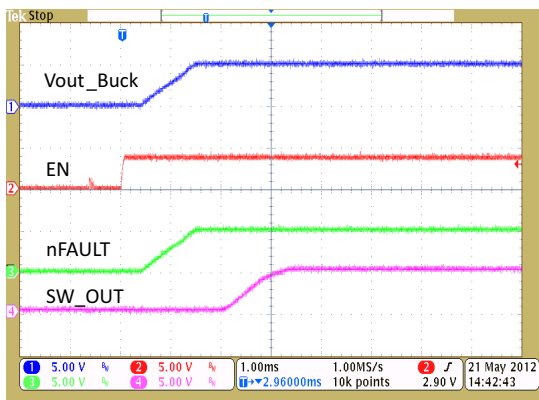

Figure 6. Power Up by EN Pin

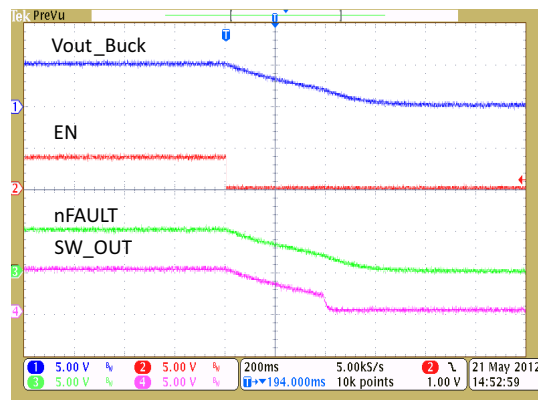

Figure 7. Power Down by EN Pin

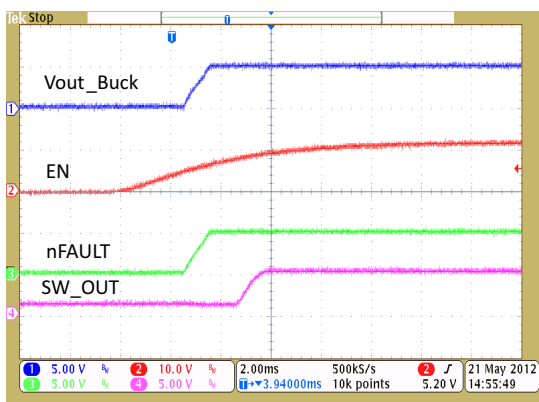

Figure 8. Power Up by V_{IN}
(EN pin connects to V_{IN} with a 10-k Ω resistor)

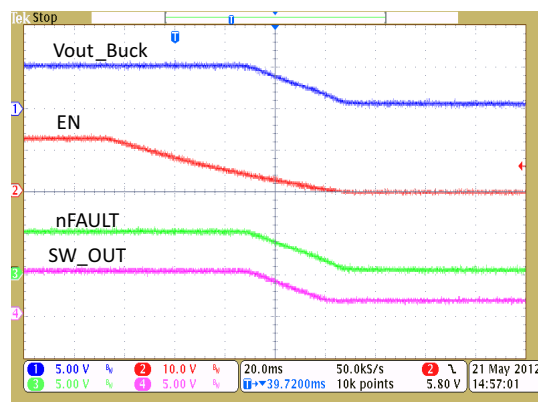

Figure 9. Power Down by V_{IN}

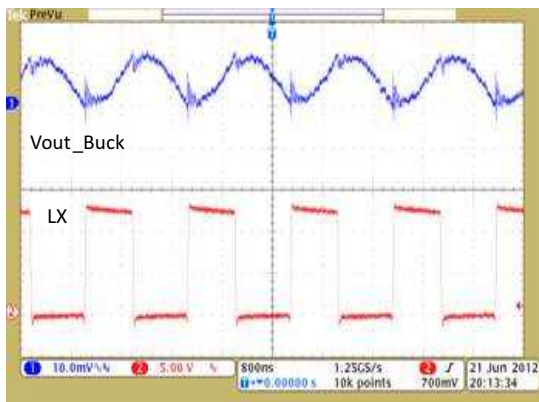

Figure 10. V_{OUT} Ripple and LX

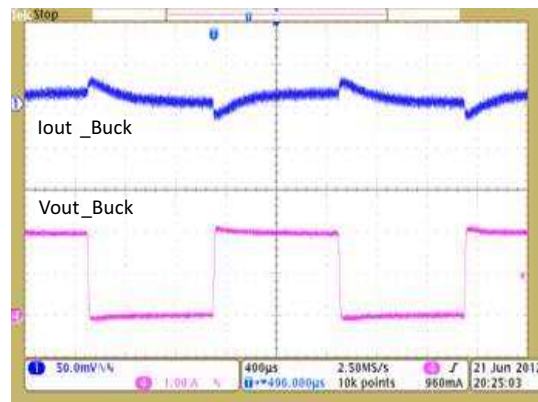

Figure 11. Load Transient

TYPICAL CHARACTERISTICS (continued)

$T_J = 25^\circ\text{C}$, $V_{IN} = 12\text{ V}$, $f_{SW} = 600\text{ kHz}$, $R_{nFAULT} = 100\text{ k}\Omega$ (unless otherwise noted)

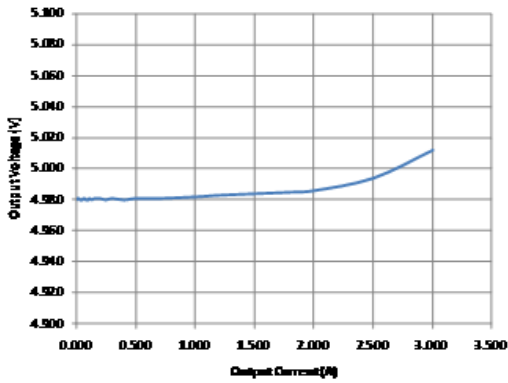

Figure 12. Buck Load Regulation

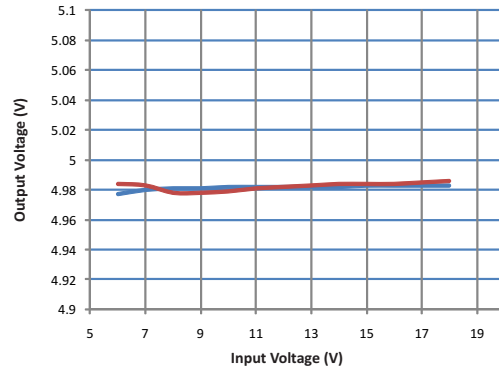

Figure 13. Buck Line Regulation

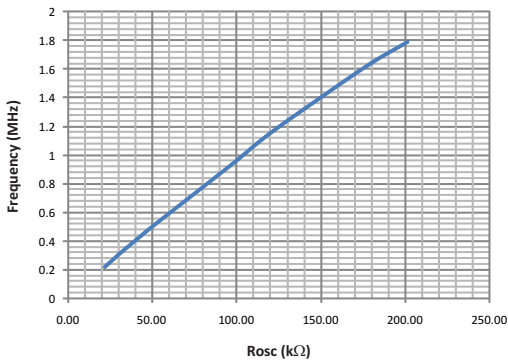

Figure 14. Oscillator Frequency vs Rosc Voltage

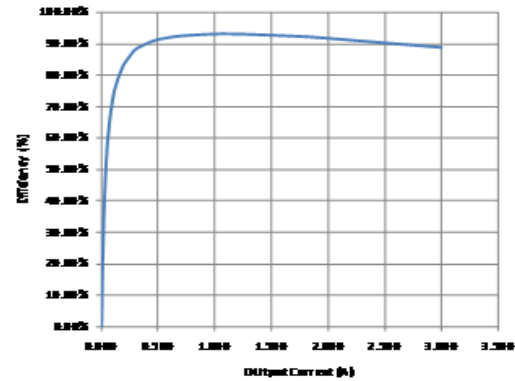

Figure 15. Buck Efficiency

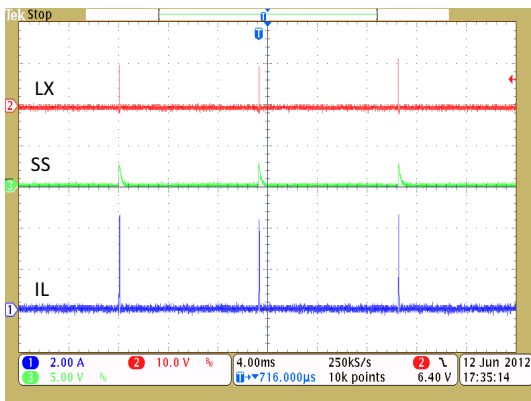

Figure 16. Buck Hiccup Response to Hard-Short Circuit

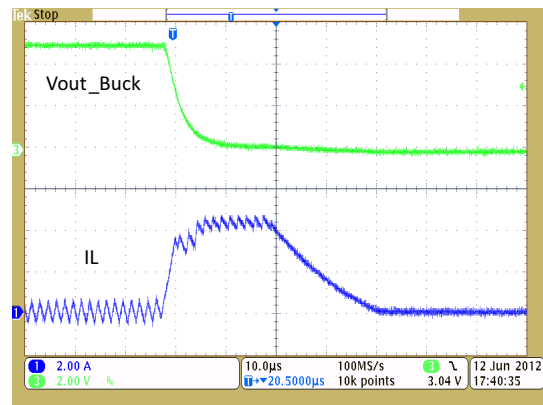

Figure 17. Zoom In Buck Output Hard Short Response

TYPICAL CHARACTERISTICS (continued)

$T_J = 25^\circ\text{C}$, $V_{IN} = 12\text{ V}$, $f_{SW} = 600\text{ kHz}$, $R_{nFAULT} = 100\text{ k}\Omega$ (unless otherwise noted)

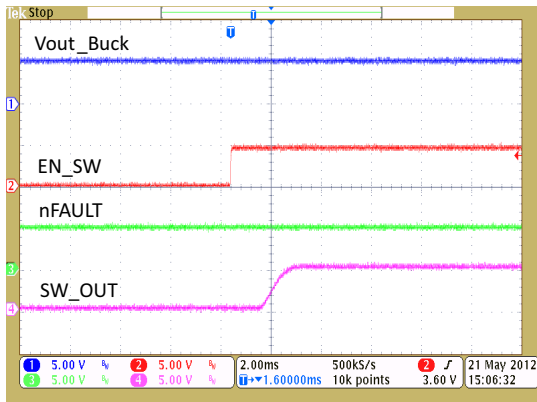

Figure 18. Power Switch Turn On Delay and Rise Time

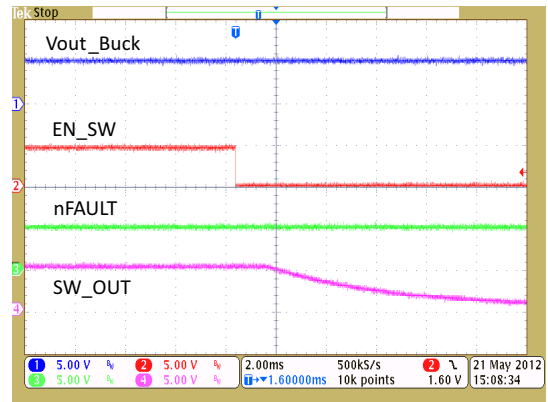

Figure 19. Power Switch Turn Off Delay and Fall Time

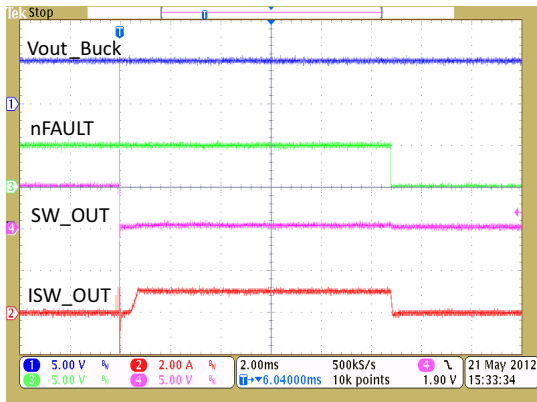

Figure 20. Power Switch Hard Short (Latch Off Version)

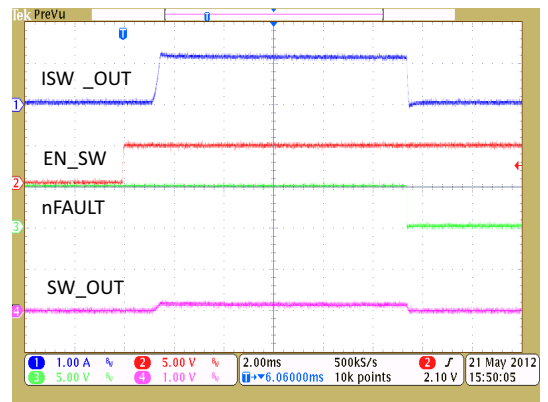

Figure 21. Power Switch Starts up to Short Circuit (Latch Off Version)

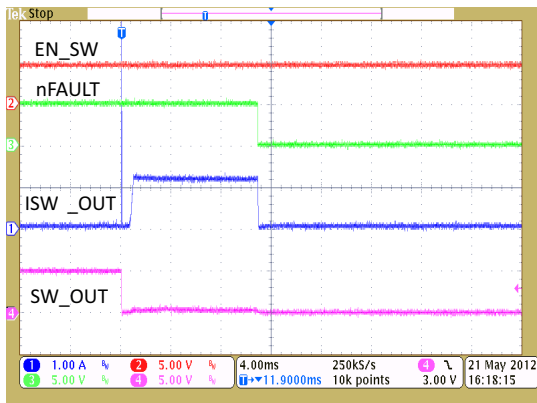

Figure 22. Power Switch No Load to 2-Ω Resistor (Latch Off Version)

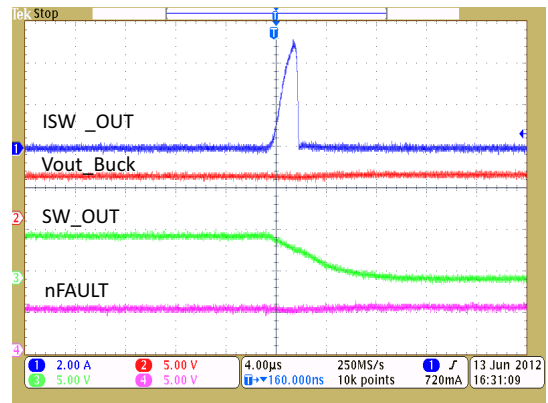

Figure 23. Power Switch Response Time (T_{IOS}) to Output Hard Short

TYPICAL CHARACTERISTICS (continued)

$T_J = 25^\circ\text{C}$, $V_{IN} = 12\text{ V}$, $f_{SW} = 600\text{ kHz}$, $R_{nFAULT} = 100\text{ k}\Omega$ (unless otherwise noted)

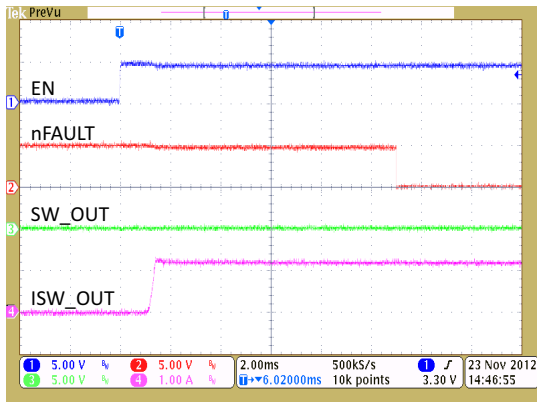

Figure 24. Power Switch Hard Short (Auto-Recovery Version)

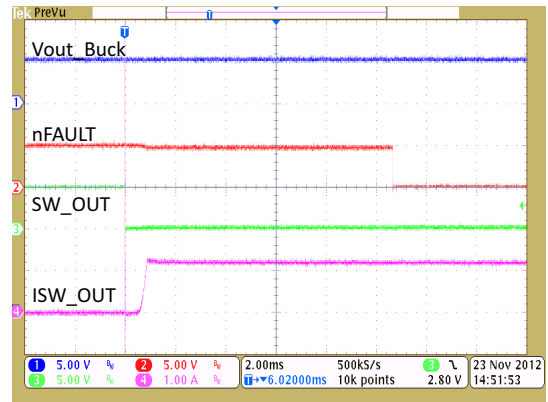

Figure 25. Power Switch Starts Up to Short Circuit (Auto-Recovery Version)

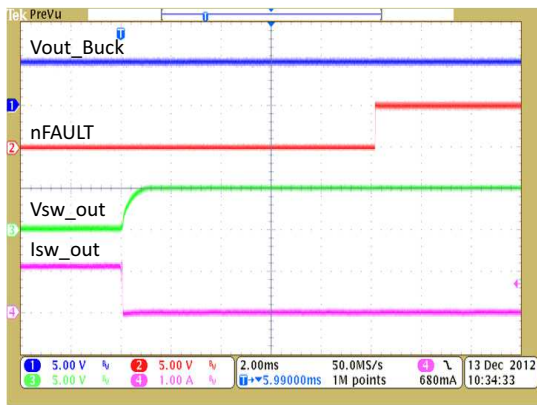

Figure 26. Power Switch Recover from Over Current (Auto-Recovery Version)

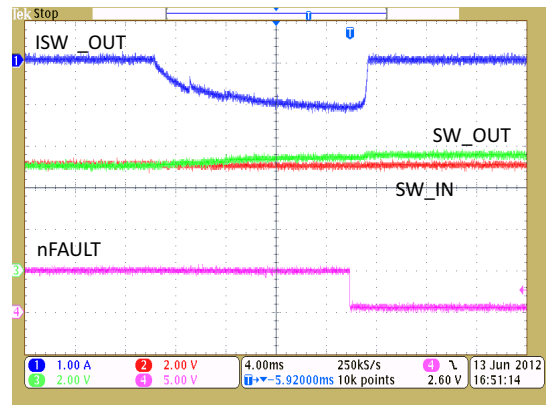

Figure 27. Power Switch Reverse Voltage Protection Response

OVERVIEW

TPS65281/TPS65281-1 PMIC integrates a current-limited, power distribution switch using N-channel MOSFETs for applications where short circuits or heavy capacitive loads will be encountered and provide a precision current limit protection. Additional device features include over temperature protection and reverse-voltage protection. The device incorporates an internal charge pump and gate drive circuitry necessary to drive the N-channel MOSFET. The charge pump supplies power to the driver circuit and provide the necessary voltage to pull the gate of the MOSFET above the source. The charge pump operates from input voltage of power switch as low as 2.5 V and requires little supply current. The driver incorporates circuitry that controls the rise and fall times of output voltage to limit large current and voltage surges and provides built-in soft-start functionality. TPS65281-1 device limits output current to a safe level by using a constant current mode when the output load exceeds the current limit threshold. TPS65281 device latches off when the load exceeds the current limit threshold. The device asserts the nFAULT signal during over current or reverse voltage faulty condition.

TPS65281/TPS65281-1 PMIC also integrates a synchronous step-down converter with a fixed 5-V output voltage to provide the power for power switches in the USB ports. The synchronous buck converter incorporates a 90-mΩ high side power MOSFET and 70-mΩ low side power MOSFET to achieve high efficiency power conversion. The converter supports an input voltage range from 4.5 V to 18 V. The converter operates in continuous conduction mode with peak current mode control for simplified loop compensation. The switching clock frequency can be programmed from 300 kHz to 1.4 MHz from the ROSC pin connection. The peak inductor current limit threshold is internally set at 4 A typical. The device builds in an internal 1-ms soft-start time to reduce inrush current during power-up.

POWER SWITCH DETAILED DESCRIPTION

Over Current Condition

The TPS65281/TPS65281-1 responds to over-current conditions on power switches by limiting the output currents to the I_{OCP_SW} level, which is fixed internally. The load current is less than the current-limit threshold and the device does not limit current. During normal operation the N-channel MOSFET is fully enhanced, and $V_{SW_OUT} = V_{SW_IN} - (I_{SW_OUT} \times R_{dson_SW})$. The voltage drop across the MOSFET is relatively small compared to V_{SW_IN} , and $V_{SW_OUT} \approx V_{SW_IN}$. When an over current condition is detected, the device maintains a constant output current and reduces the output voltage accordingly. During current-limit operation, the N-channel MOSFET is no longer fully enhanced and the resistance of the device increases. This allows the device to effectively regulate the current to the current-limit threshold. The effect of increasing the resistance of the MOSFET is that the voltage drop across the device is no longer negligible ($V_{SW_IN} \neq V_{SW_OUT}$), and V_{SW_OUT} decreases. The amount that V_{SW_OUT} decreases is proportional to the magnitude of the overload condition. The expected V_{SW_OUT} can be calculated by $I_{OS} \times R_{LOAD}$, where I_{OS} is the current-limit threshold and R_{LOAD} is the magnitude of the overload condition.

Three possible overload conditions can occur as summarized in [Table 1](#).

Table 1. Possible Overload Conditions

CONDITIONS	BEHAVIORS
Short circuit or partial short circuit present when the device is powered up or enabled	The output voltage is held near zero potential with respect to ground and the TPS65281 ramps output current to I_{OCP_SW} . The TPS65281-1 will limit the current to I_{OS} until the overload condition is removed or the device begins to thermal cycle. The TPS65281 limits the current to I_{OS} until the overload condition is removed or the internal deglitch time (10 ms typical) is reached and the device is turned off. The device will remain off until power is cycled or the device enable is toggled.
Gradually increasing load (<100 A/s) from normal operating current to I_{OS}	The current rises until current limit. Once the threshold has been reached, the device switches into its current limiting at I_{OS} . The TPS65281-1 will limit the current to I_{OS} until the overload condition is removed or the device begins to thermal cycle. The TPS65281 limits the current to I_{OS} until the overload condition is removed or the internal deglitch time (10 ms typical) is reached and the device is turned off. The device will remain off until power is cycled or the device enable is toggled.
Short circuit, partial short circuit or fast transient overload occurs while the device is enabled and powered on	The device responds to the over-current condition within time t_{IOS} (see Figure 5). The current sensing amplifier is overdriven during this time, and needs time for loop response. Once t_{IOS} has passed, the current sensing amplifier recovers and limits the current to I_{OS} . The TPS65281-1 will limit the current to I_{OS} until the overload condition is removed or the device begins to thermal cycle. The TPS65281 limits the current to I_{OS} until the overload condition is removed or the internal deglitch time (10 ms typical) is reached and the device is turned off. The device will remain off until power is cycled or the device enable is toggled.

The TPS65281-1 thermal cycles if an overload condition is present long enough to activate thermal limiting in any of the above cases. The power switch turns off when the junction temperature exceeds 145°C (typical) while in current limit. The device remains off until the junction temperature cools 10°C (typical) and then restarts. The TPS65281-1 cycles on and off until the overload is removed.

Reverse Current and Voltage Protection

A power switch in the TPS65281/TPS65281-1 incorporates two back-to-back N-channel power MOSFETs as to prevent the reverse current flowing back the input through body diode of MOSFET when power switches are off.

The reverse-voltage protection feature turns off the N-channel MOSFET whenever the output voltage exceeds the input voltage by 135 mV (typical) for 4 ms (typical). This prevents damage to devices on the input side of the TPS65281/TPS65281-1 by preventing significant current from sinking into the input capacitance of power switch or buck output capacitance. The TPS65281-1 device allows the N-channel MOSFET to turn on once the output voltage goes below the input voltage for the same 4-ms deglitch time. The TPS65281 device keeps the power switch turned off even if the reverse-voltage condition is removed and do not allow the N-channel MOSFET to turn on until power is cycled or the device enable is toggled. The reverse-voltage comparator also asserts the nFAULT output (active-low) after 4 ms.

nFAULT Response

The nFAULT open-drain output is asserted (active low) during an over current, over temperature or reverse-voltage condition. The TPS65281-1 asserts the nFAULT signal until the fault condition is removed and the device resumes normal operation. The TPS65281 asserts the nFAULT signal during a fault condition and remains asserted while the part is latched-off. The nFAULT signal is de-asserted once device power is cycled or the enable is toggled and the device resumes normal operation. The TPS65281/TPS65281-1 is designed to eliminate false nFAULT reporting by using an internal delay deglitch circuit for over current (10 ms typical) and reverse-voltage (4 ms typical) conditions without the need for external circuitry. This ensures that nFAULT is not accidentally asserted due to normal operation such as starting into a heavy capacitive load. Deglitching circuitry delays entering and leaving fault conditions. Over temperature conditions are not deglitched and assert the FAULT signal immediately.

Under-Voltage Lockup (UVLO)

The under-voltage lockout (UVLO) circuit disables the power switch until the input voltage reaches the UVLO turn-on threshold. Built-in hysteresis prevents unwanted on/off cycling due to input voltage drop from large current surges.

Enable and Output Discharge

The logic enable EN_SW controls the power switch, bias for the charge pump, driver, and other circuits. The supply current from power switch driver is reduced to less than 1 μ A when a logic low is present on EN_SW. A logic high input on EN_SW enables the driver, control circuits, and power switch. There is 2.5-M Ω pull-up resistor connecting to EN_SW pin. After power switch is turned on, the resistor is switched to 1.25 M Ω . The enable input is compatible with both TTL and CMOS logic levels. Floating the pin is not recommended.

When enable is de-asserted, the discharge function is active. The output capacitor of power switch is discharged through an internal NMOS that has a discharge resistance of 100 Ω . Hence, the output voltage drops down to zero. The time taken for discharge is dependent on the RC time constant of the resistance and the output capacitor.

Power Switch Input and Output Capacitance

Input and output capacitance improves the performance of the device. The actual capacitance should be optimized for the particular application. The output capacitor of buck should be placed as close to the SW_IN and AGND if the integrated buck supply the power to power switch. For the application which input to power switch is from another supply, a 0.1- μ F or greater ceramic bypass capacitor between SW_IN and AGND is recommended as close to the device as possible for local noise de-coupling. This precaution reduces ringing on the input due to power-supply transients. Additional capacitance may be needed on the input to reduce voltage overshoot from exceeding the absolute maximum voltage of the device during heavy transient conditions. This is especially important during bench testing when long, inductive cables are used to connect the input of power switches in the evaluation board to the bench power-supply.

Placing a high-value electrolytic capacitor on the output pin is recommended when large transient currents are expected on the output.

Programming the Current-Limit Threshold

The over-current threshold is user programmable via an external resistor. The TPS65281/TPS65281-1 uses an internal regulation loop to provide a regulated voltage on the RLIM pin. The current-limit threshold is proportional to the current sourced out of RLIM. The recommended 1% resistor range for RLIM is $5\text{ k}\Omega \leq \text{RLIM} \leq 232\text{ k}\Omega$ to ensure stability of the internal regulation loop. Many applications require that the minimum current limit is above a certain current level or that the maximum current limit is below a certain current level, so it is important to consider the tolerance of the over-current threshold when selecting a value for RLIM. The following equations and Figure 28 can be used to calculate the resulting over-current threshold for a given external resistor value (RLIM). The traces routing the RLIM resistor to the TPS65281/TPS65281-1 should be as short as possible to reduce parasitic effects on the current-limit accuracy.

RLIM can be selected to provide a current-limit threshold that occurs 1) above a minimum load current or 2) below a maximum load current.

Current-Limit Threshold Equations (IOS):

$$I_{osmax} = \left(\frac{22980 \cdot V}{\text{RLIM}^{0.94} \cdot \text{K}\Omega} \right) (\text{mA}) \tag{1}$$

$$I_{osnom} = \left(\frac{23950 \cdot V}{\text{RLIM}^{0.977} \cdot \text{K}\Omega} \right) (\text{mA}) \tag{2}$$

$$I_{osmin} = \left(\frac{25230 \cdot V}{\text{RLIM}^{1.016} \cdot \text{K}\Omega} \right) (\text{mA}) \tag{3}$$

Where $15\text{ k}\Omega \leq \text{RLIM} \leq 232\text{ k}\Omega$.

While the maximum recommended value of RLIM is 232 kΩ, there is one additional configuration that allows for a lower current-limit threshold. The RLIM pin may be connected directly to SW_IN to provide a 1.2 A (typ) current-limit threshold. Additional low-ESR ceramic capacitance may be necessary from SW_IN to AGND in this configuration to prevent unwanted noise from coupling into the sensitive RLIM circuitry.

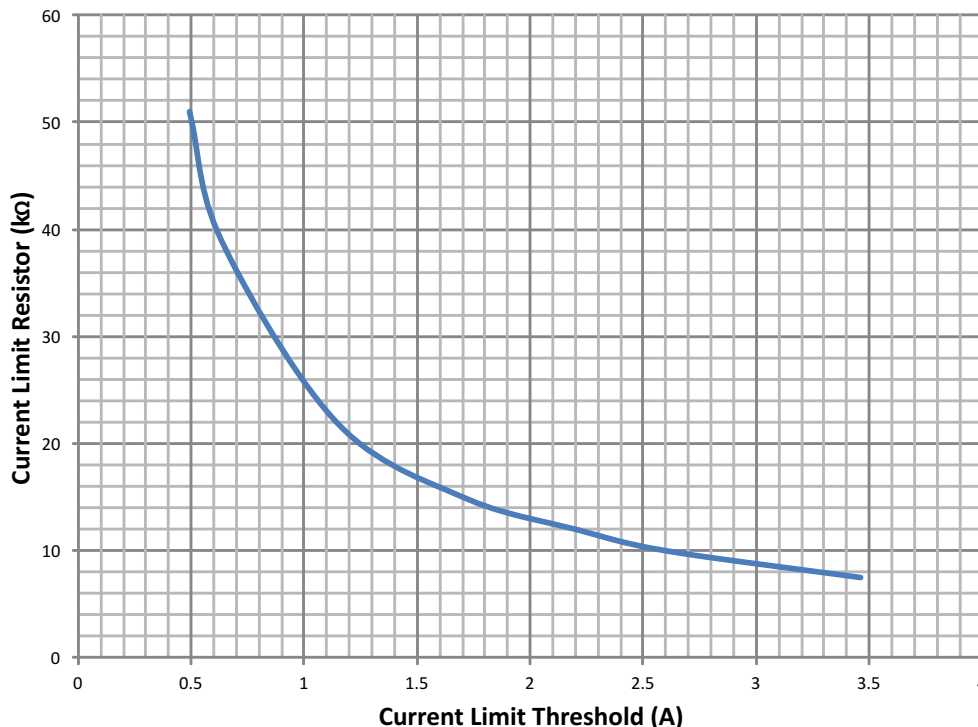

Figure 28. Current Limit Threshold (I_{os}) vs Current Limit Resistor (RLIM)

Constant-Current vs. Latch-Off Operation and Impact on Output Voltage

Both the constant-current device (TPS65281-1) and latch-off device (TPS65281) operate identically during normal operation, i.e. the load current is less than the current-limit threshold and the devices are not limiting current. During normal operation the N-channel MOSFET is fully enhanced, and $V_{SW_OUT} = V_{SW_IN} - (I_{SW_OUT} \times r_{DS(on)})$. The voltage drop across the MOSFET is relatively small compared to V_{SW_IN} , and $V_{SW_OUT} \approx V_{SW_IN}$.

Both the constant-current device (TPS65281-1) and latch-off device (TPS65281) operate identically during the initial onset of an over-current event. Both devices limit current to the programmed current-limit threshold set by RLIM by operating the N-channel MOSFET in the linear mode. During current-limit operation, the N-channel MOSFET is no longer fully-enhanced and the resistance of the device increases. This allows the device to effectively regulate the current to the current-limit threshold. The effect of increasing the resistance of the MOSFET is that the voltage drop across the device is no longer negligible ($V_{SW_IN} \neq V_{SW_OUT}$), and V_{SW_OUT} decreases. The amount that V_{SW_OUT} decreases is proportional to the magnitude of the overload condition. The expected V_{SW_OUT} can be calculated by $I_{OCP_SW} \times R_{LOAD}$, where I_{OCP_SW} is the current-limit threshold and R_{LOAD} is the magnitude of the overload condition.

For example, if I_{OCP_SW} is programmed to 1 A and a 1- Ω overload condition is applied, the resulting V_{OUT} is 1 V.

While both the constant-current device (TPS65281-1) and latch-off device (TPS65281) operate identically during the initial onset of an overcurrent event, they behave differently if the overcurrent event lasts longer than the internal delay deglitch circuit (10 ms typical). The constant-current device (TPS65281-1) asserts the FAULT flag after the deglitch period and continues to regulate the current to the current-limit threshold indefinitely. In practical circuits, the power dissipation in the package will increase the die temperature above the overtemperature shutdown threshold (145°C typical), and the device will turn off until the die temperature decreases by the hysteresis of the thermal shutdown circuit (10°C typical). The device will turn on and continue to thermal cycle until the overload condition is removed. The constant-current devices resume normal operation once the overload condition is removed. The latch-off device (TPS65281) asserts the FAULT flag after the deglitch period and immediately turns off the device. The device remains off regardless of whether the overload condition is removed from the output. The latch-off device remains off and do not resume normal operation until the surrounding system either toggles the enable or cycles power to the device.

UNIVERSAL SERIAL BUS (USB) POWER-DISTRIBUTION REQUIREMENTS

One application for this device is for current limiting in universal serial bus (USB) applications. The original USB interface was a 12-Mb/s or 1.5-Mb/s, multiplexed serial bus designed for low-to-medium bandwidth PC peripherals (e.g., keyboards, printers, scanners, and mice). As the demand for more bandwidth increased, the USB 2.0 standard was introduced increasing the maximum data rate to 480-Mb/s. The four-wire USB interface is conceived for dynamic attach-detach (hot plug-unplug) of peripherals. Two lines are provided for differential data, and two lines are provided for 5-V power distribution.

USB data is a 3.3-V level signal, but power is distributed at 5 V to allow for voltage drops in cases where power is distributed through more than one hub across long cables. Each function must provide its own regulated 3.3 V from the 5-V input or its own internal power supply. The USB specification classifies two different classes of devices depending on its maximum current draw. A device classified as low-power can draw up to 100 mA as defined by the standard. A device classified as high-power can draw up to 500 mA. It is important that the minimum current-limit threshold of the current-limiting power-switch exceed the maximum current-limit draw of the intended application. The latest USB standard should always be referenced when considering the current-limit threshold.

The USB specification defines two types of devices as hubs and functions. A USB hub is a device that contains multiple ports for different USB devices to connect and can be self-powered (SPH) or bus-powered (BPH). A function is a USB device that is able to transmit or receive data or control information over the bus. A USB function can be embedded in a USB hub. A USB function can be one of three types included in the list below.

- Low-power, bus-powered function
- High-power, bus-powered function
- Self-powered function

SPHs and BPHs distribute data and power to downstream functions. The TPS65281 has higher current capability than required for a single USB port allowing it to power multiple downstream ports.

Self-Powered and Bus-Powered HUBs

A SPH has a local power supply that powers embedded functions and downstream ports. This power supply must provide between 4.75 V and 5.25 V to downstream facing devices under full-load and no-load conditions. SPHs are required to have current-limit protection and must report over-current conditions to the USB controller. Typical SPHs are desktop PCs, monitors, printers, and stand-alone hubs.

A BPH obtains all power from an upstream port and often contains an embedded function. It must power up with less than 100 mA. The BPH usually has one embedded function, and power is always available to the controller of the hub. If the embedded function and hub require more than 100 mA on power up, the power to the embedded function may need to be kept off until enumeration is completed. This is accomplished by removing power or by shutting off the clock to the embedded function. Power switching the embedded function is not necessary if the aggregate power draw for the function and controller is less than 100 mA. The total current drawn by the bus-powered device is the sum of the current to the controller, the embedded function, and the downstream ports, and it is limited to 500 mA from an upstream port.

Low-Power Bus-Powered and High-Power Bus-Powered Functions

Both low-power and high-power bus-powered functions obtain all power from upstream ports. Low-power functions always draw less than 100 mA; high-power functions must draw less than 100 mA at power up and can draw up to 500 mA after enumeration. If the load of the function is more than the parallel combination of 44 Ω and 10 μF at power up, the device must implement inrush current limiting.

USB Power Distribution Requirements

USB can be implemented in several ways regardless of the type of USB device being developed. Several power-distribution features must be implemented.

SPHs must:

- Current limit downstream ports
- Report over-current conditions

BPHs must:

- Enable/disable power to downstream ports
- Power up at < 100 mA
- Limit inrush current (< 44 Ω and 10 μF)

Functions must:

- Limit inrush currents
- Power up at < 100 mA

The feature set of the TPS65281 meets each of these requirements. The integrated current limiting and over-current reporting is required by self-powered hubs. The logic-level enable and controlled rise times meet the need of both input and output ports on bus-powered hubs and the input ports for bus-powered functions.

BUCK DC/DC CONVERTER DETAILED DESCRIPTION

Output Voltage

The TPS65281/TPS65281-1 regulates output voltage set by a feedback resistor divider to 0.8-V reference voltage. This pin should be directly connected to middle of resistor divider. It is recommended to use 1% tolerance or better divider resistors. Great care should be taken to route the FB line away from noise sources, such as the inductor or the LX switching node line. Start with 40.2 k Ω for the R1 resistor and use Equation 4 to calculate R2.

$$R_2 = R_1 \cdot \left(\frac{0.8V}{V_{OUT} - 0.8V} \right) \quad (4)$$

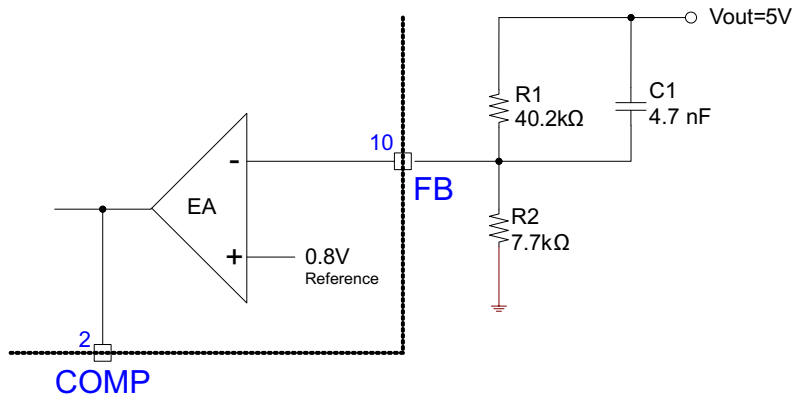

Figure 29. Buck Feedback Resistor Divider

Switching Frequency Selection

The selection of switching frequency is a tradeoff between efficiency and component size. Low frequency operation increases efficiency by reducing MOSFET switching losses, but requires larger inductance and capacitance to maintain low output ripple voltage. The switching frequency of the TPS65281/TPS65281-1 buck controller can be selected with the connection at ROSC pin. The ROSC pin can be connected to AGND, tied to V7V, open or programmed through an external resistor. Tying ROSC pin to AGND selects 300 kHz, while tying ROSC pin to V7V or floating ROSC pin selects 600 kHz. Placing a resistor between ROSC and AGND allows the buck switching frequency to be programmed between 300 kHz to 1.4 MHz, as shown in Figure 14. The programmed clock frequency by an external resistor can be calculated with the following equation:

$$f_{sw} = 10 \times R_{osc} \quad (5)$$

Soft-Start Time

The start-up of buck output is controlled by the voltage on the SS pin. When the voltage on the SS pin is less than the internal 0.8-V reference, the TPS65281/TPS65281-1 regulates the internal feedback voltage to the voltage on the SS pin instead of 0.8 V. The SS pin can be used to program an external soft-start function or to allow output of the buck to track another supply during start-up. The device has an internal pull-up current source of 4.7 μ A that charges an external soft-start capacitor to provide a linear ramping voltage at SS pin. The TPS65281 will regulate the internal feedback voltage according to the voltage on the SS pin, allowing V_{OUT} to rise smoothly from 0 V to its final regulated value. The total soft-start time will be approximately:

$$T_{ss} = C_{ss} \cdot \left(\frac{0.8 \cdot V}{4.7 \cdot \mu A} \right) \quad (6)$$

Internal V7V Regulator

The TPS65281/TPS65281-1 features an internal P-channel low dropout linear regulator (LDO) that supplies power at the V7V pin from the VIN supply. V7V powers the gate drivers and much of the TPS65281/TPS65281-1's internal circuitry. The LDO regulates V7V to 6.3 V of over drive voltage on the power MOSFET for the best efficiency performance. The LDO can supply a peak current of 50 mA and must be bypassed to ground with a minimum 1- μ F ceramic capacitor. The capacitor placed directly adjacent to the V7V and PGND pins is highly recommended to supply the high transient currents required by the MOSFET gate drivers.

Short Circuit Protection

During the PWM on-time, the current through the internal high side switching MOSFET is sampled. The sampled current is compared to a nominal 5-A over-current limit. If the sampled current exceeds the over-current limit reference level, an internal over-current fault counter is set to 1 and an internal flag is set. Both internal high side and low side power MOSFETs are immediately turned off and will not be turned on again until the next switching cycle. If the over-current condition persists for eight sequential clock cycles, the over-current fault counter overflows indicating an over-current fault condition exists. The buck regulator is shut down and stays turned off for 10 ms. If the over-current condition clears prior to the counter reaching eight consecutive cycles, the internal flag and counter are reset. The protection circuitry attempts to recover from the over-current condition after 10-ms power down time. The internal over-current flag and counter are reset. A normal soft-start cycle is attempted and normal operation continues if the over-current fault condition has cleared. If the over-current fault counter overflows during soft-start, the converter shuts down and this hiccup mode operation repeats.

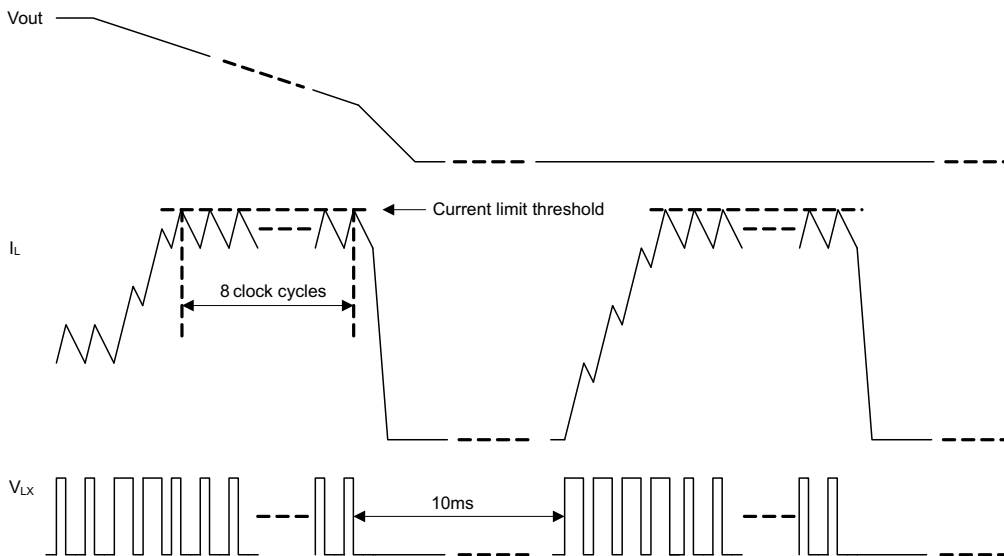

Figure 30. DC/DC Over-Current Protection

Inductor Selection

The higher operating frequency allows the use of smaller inductor and capacitor values. A higher frequency generally results in lower efficiency because of MOSFET gate charge losses. In addition to this basic trade-off, the effect of the inductor value on ripple current and low current operation must also be considered. The ripple current depends on the inductor value. The inductor ripple current, i_L , decreases with higher inductance or higher frequency and increases with higher input voltage, V_{IN} . Accepting larger values of i_L allows the use of low inductances, but results in higher output voltage ripple and greater core losses.

Use Equation 7 to calculate the value of the output inductor. LIR is a coefficient that represents inductor peak-to-peak ripple to DC load current. It is suggested to use 0.1 ~ 0.3 for most LIR applications.

Actual core loss of the inductor is independent of core size for a fixed inductor value, but it is dependent on the inductance value selected. As inductance increases, core losses decrease. Unfortunately, increased inductance requires more turns of wire and therefore copper losses will increase. Ferrite designs have very low core loss and are preferred for high switching frequencies, so design goals can concentrate on copper loss and preventing saturation. Ferrite core material saturates hard, which means that inductance collapses abruptly when the peak design current is exceeded. It results in an abrupt increase in inductor ripple current and consequent output voltage ripple. Do not allow the core to saturate. It is important that the RMS current and saturation current ratings are not exceeding the inductor specification. The RMS and peak inductor current can be calculated from Equation 9 and Equation 10.

$$L = \frac{V_{in} - V_{out}}{I_O \cdot LIR} \cdot \frac{V_{out}}{V_{in} \cdot f_{sw}} \tag{7}$$

$$\Delta i_L = \frac{V_{in} - V_{out}}{L} \cdot \frac{V_{out}}{V_{in} \cdot f_{sw}} \tag{8}$$

$$i_{Lrms} = \sqrt{I_O^2 + \frac{\left(\frac{V_{out} \cdot (V_{inmax} - V_{out})}{V_{inmax} \cdot L \cdot f_{sw}}\right)^2}{12}} \tag{9}$$

$$I_{Lpeak} = I_O + \frac{\Delta i_L}{2} \tag{10}$$

For this design example, use LIR = 0.3, and the inductor is calculated to be 5.40 μH with V_{IN} = 12 V, V_{OUT} = 5 V and f_{SW} = 600 kHz. Choose a 4.7 μH standard inductor, the peak to peak inductor ripple is about 34% of 3-A DC load current.

Output Capacitor Selection

There are two primary considerations for selecting the value of the output capacitor. The output capacitors are selected to meet load transient and output ripple's requirements.

Equation 11 gives the minimum output capacitance to meet the transient specification. For this example, L_O = 4.7 μH, ΔI_{OUT} = 3 A – 0.0 A = 3 A and ΔV_{OUT} = 500 mV (10% of regulated 5 V). Using these numbers gives a minimum capacitance of 17 μF. A standard 22 μF ceramic capacitor is used in the design.

$$C_o > \frac{\Delta I_{OUT}^2 \cdot L}{V_{out} \cdot \Delta V_{out}} \tag{11}$$

The selection of C_{OUT} is driven by the effective series resistance (ESR). Equation 12 calculates the minimum output capacitance needed to meet the output voltage ripple specification. Where f_{SW} is the switching frequency, ΔV_{OUT} is the maximum allowable output voltage ripple, and Δi_L is the inductor ripple current. In this case, the maximum output voltage ripple is 50 mV (1% of regulated 5 V). From Equation 8, the output current ripple is 1 A. From Equation 12, the minimum output capacitance meeting the output voltage ripple requirement is 4.6 μF with 3-mΩ esr resistance.

$$C_o > \frac{1}{8 \cdot f_{sw}} \cdot \frac{1}{\frac{\Delta V_{out}}{\Delta i_L} - esr} \tag{12}$$

After considering both requirements, for this example, one 22 μF 6.3 V X7R ceramic capacitor with 3 mΩ of ESR will be used.

Input Capacitor Selection

A minimum 10 μF X7R/X5R ceramic input capacitor is recommended to be added between VIN and GND. These capacitors should be connected as close as physically possible to the input pins of the converters, as they handle the RMS ripple current shown in Equation 13. For this example, I_{OUT} = 2 A, V_{OUT} = 5 V, minimum V_{in_min} = 9.6 V. The input capacitors must support a ripple current of 1 A RMS.

$$I_{inrms} = I_{out} \cdot \sqrt{\frac{V_{out}}{V_{inmin}} \cdot \frac{(V_{inmin} - V_{out})}{V_{inmin}}} \tag{13}$$

The input capacitance value determines the input ripple voltage of the regulator. The input voltage ripple can be calculated using Equation 14. Using the design example values, $I_{out_max} = 2\text{ A}$, $C_{IN} = 10\text{ }\mu\text{F}$, $f_{SW} = 600\text{ kHz}$, yields an input voltage ripple of 83 mV.

$$\Delta V_{in} = \frac{I_{out_max} \cdot 0.25}{C_{in} \cdot f_{sw}} \quad (14)$$

To prevent large voltage transients, a low ESR capacitor sized for the maximum RMS current must be used.

Bootstrap Capacitor Selection

The external bootstrap capacitor connected to the BST pins supply the gate drive voltages for the toplevel MOSFETs. The capacitor between BST pin and LX pin is charged through an internal diode from V_{7V} when the LX pin is low. When high side MOSFETs are to be turned on, the driver places the bootstrap voltage across the gate-source of the desired MOSFET. This enhances the top MOSFET switch and turns it on. The switch node voltage, LX, rises to V_{IN} and the BST pin follows. With the internal high side MOSFET on, the bootstrap voltage is above the input supply: $V_{BST} = V_{IN} + V_{7V}$. The selection on bootstrap capacitance is related with internal high side power MOSFET gate capacitance. A 0.047- μF ceramic capacitor is recommended to be connected between the BST to LX pin for proper operation. It is recommended to use a ceramic capacitor with X5R or better grade dielectric. The capacitor should have 10-V or higher voltage rating.

Loop Compensation

The integrated buck DC/DC converter in TPS65281 incorporates a peak current mode. The error amplifier is a trans-conductance amplifier with a gain of 500 $\mu\text{A/V}$. A typical type II compensation circuit adequately delivers a phase margin between 60° and 90°. C_b adds a high frequency pole to attenuate high frequency noise when needed. To calculate the external compensation components, follow these steps:

1. Select switching frequency, f_{SW} , that is appropriate for application depending on L and C sizes, output ripple and EMI. Switching frequency between 500 kHz and 1 MHz gives the best trade off between performance and cost. To optimize efficiency, a lower switching frequency is desired.
2. Set up cross over frequency, f_c , which is typically between 1/5 and 1/20 of f_{SW} .
3. R_C can be determined by:

$$R_C = \frac{2\pi \cdot f_c \cdot V_o \cdot C_o}{g_M \cdot V_{ref} \cdot g_{m_{ps}}} \quad (15)$$

where g_m is the error amplifier gain (500 $\mu\text{A/V}$) and $g_{m_{ps}}$ is the power stage voltage to current conversion gain (20 A/V).

4. Calculate C_C by placing a compensation zero at or before the dominant pole, $f_p = \frac{1}{C_o \cdot R_L \cdot 2\pi}$.
- $$C_C = \frac{R_L \cdot C_o}{R_C} \quad (16)$$

5. Optional C_b can be used to cancel the zero from the ESR associated with C_o .

$$C_b = \frac{R_{esr} \cdot C_o}{R_C} \quad (17)$$

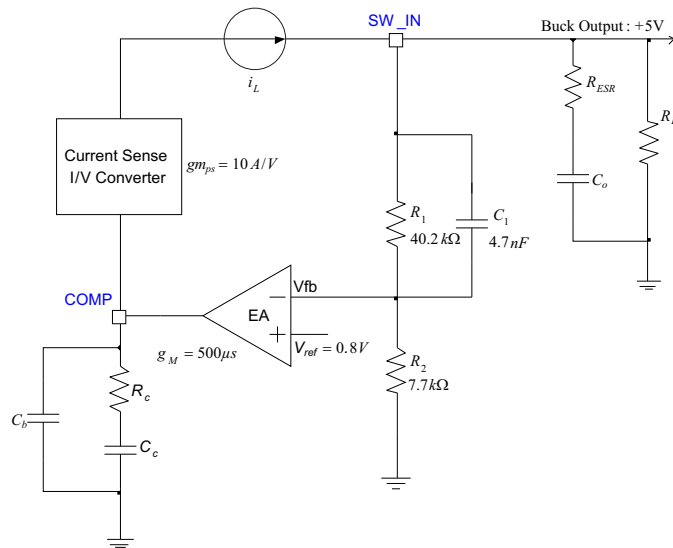

Figure 31. DC/DC Loop Compensation

APPLICATION INFORMATION

Thermal Shutdown

The device implements an internal thermal shutdown to protect itself if the junction temperature exceeds 160°C. The thermal shutdown forces the buck converter to stop switching when the junction temperature exceeds thermal trip threshold. Once the die temperature decreases below 140°C, the device reinitiates the power up sequence. The thermal shutdown hysteresis is 20°C.

Power Dissipation and Junction Temperature

The total power dissipation inside TPS65281/TPS65281-1 should not exceed the maximum allowable junction temperature of 125°C. The maximum allowable power dissipation is a function of the thermal resistance of the package, θ_{JA} , and ambient temperature. The analysis below gives an approximation in calculating junction temperature based on the power dissipation in the package. However, it is important to note that thermal analysis is strongly dependent on additional system level factors. Such factors include air flow, board layout, copper thickness and surface area, and proximity to other devices dissipating power. Good thermal design practice must include all system level factors in addition to individual component analysis.

To calculate the temperature inside the device under continuous load, use the following procedure.

1. Define the total continuous current through the buck converter (including the load current through power switches). Make sure the continuous current does not exceed the maximum load current requirement.
2. From the graphs below, determine the expected losses (Y axis) in Watts for the buck converter inside the device. The loss P_{D_BUCK} depends on the input supply and the selected switching frequency. Please note, the data is measured in the provided evaluation board (EVM).
3. Determine the load current I_{OUT} through the power switch. Read $R_{DS(on)}$ of the power switch from the Electrical Characteristics table.

4. The power loss through power switches can be calculated by:

$$P_{D_PW} = R_{DS(on)} \times I_{OUT} \quad (18)$$

5. The Dissipating Rating Table provides the thermal resistance, θ_{JA} , for specific packages and board layouts.

6. The maximum temperature inside the IC can be calculated by:

$$T_J = P_{D_BUCK} + P_{D_PW} \times \theta_{JA} + T_A \quad (19)$$

Where:

T_A = Ambient temperature (°C)

θ_{JA} = Thermal resistance (°C/W)

P_{D_BUCK} = Total power dissipation in buck converter (W)

P_{D_PW} = Total power dissipation in power switches (W)

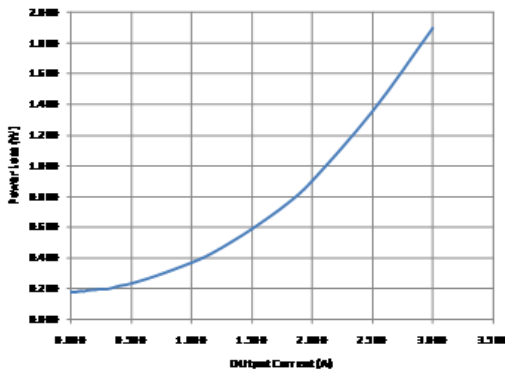

Figure 32. Buck Power Loss vs Output Current
 $V_{IN} = 12\text{ V}$, $f_{SW} = 600\text{ kHz}$

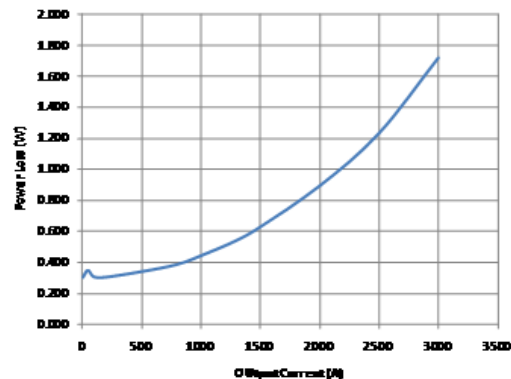

Figure 33. Buck Power Loss vs Output Current
 $V_{IN} = 12\text{ V}$, $f_{SW} = 300\text{ kHz}$

Auto-Retry Functionality

Some applications require that an over-current condition disables the part momentarily during a fault condition and re-enables after a pre-set time. This auto-retry functionality can be implemented with an external resistor and capacitor shown in [Figure 34](#). During a fault condition, nFAULT pulls low disabling the part. The part is disabled when EN is pulled low, and nFAULT goes high impedance allowing CRETRY to begin charging. The part re-enables when the voltage on EN_SW reaches the turn-on threshold, and the auto-retry time is determined by the resistor/capacitor time constant. The part will continue to cycle in this manner until the fault condition is removed.

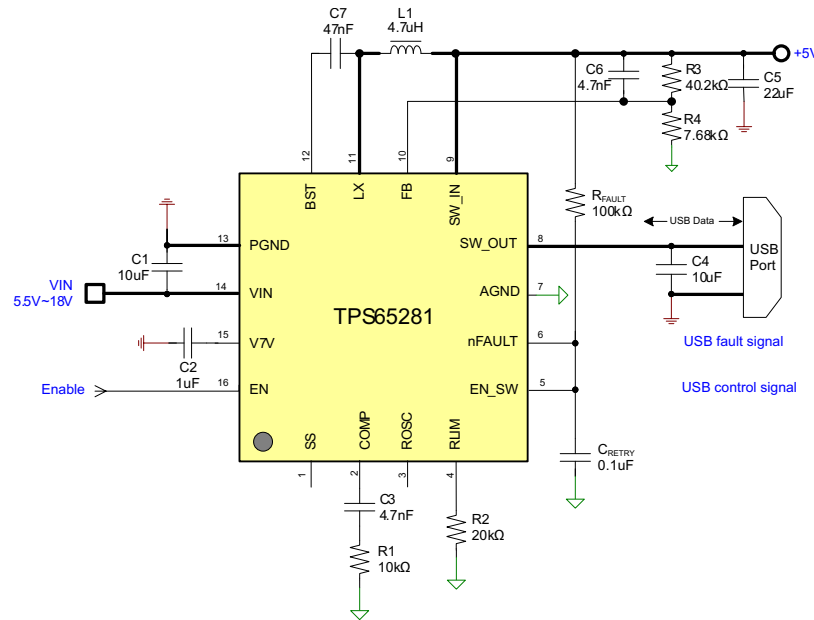

Figure 34. Auto Retry Functionality

Some applications require auto-retry functionality and the ability to enable/disable with an external logic signal. [Figure 35](#) shows how an external logic signal can drive EN_SW through RFAULT and maintain auto-retry functionality. The resistor/capacitor time constant determines the auto-retry time-out period.

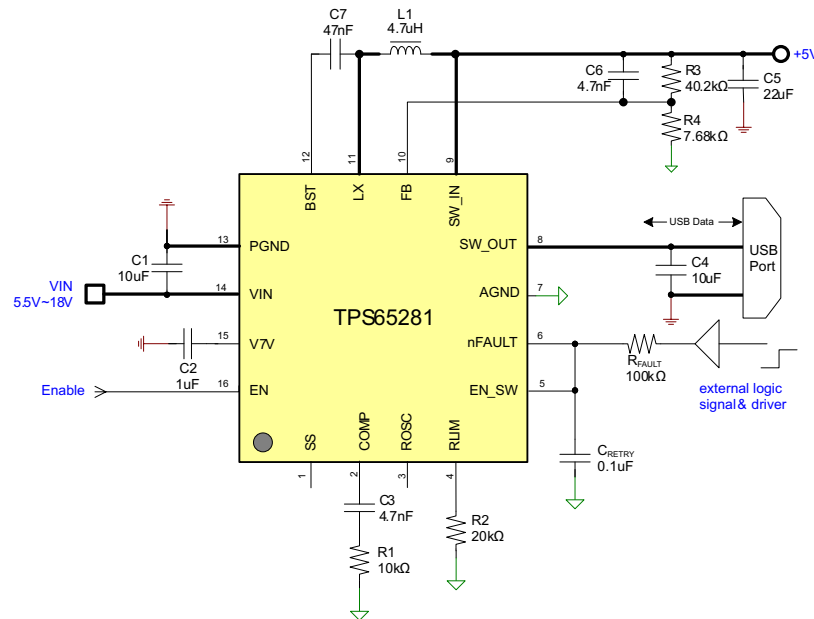

Figure 35. Auto Retry Functionality With External Enable Signal

PCB Layout Recommendation

When laying out the printed circuit board, the following guidelines should be used to ensure proper operation of the IC. These items are also illustrated graphically in the layout diagram of [Figure 36](#).

- There are several signal paths that conduct fast changing currents or voltages that can interact with stray inductance or parasitic capacitance to generate noise or degrade the power supplies performance. To help eliminate these problems, the VIN pin should be bypassed to ground with a low ESR ceramic bypass capacitor with X5R or X7R dielectric. This capacitor provides the AC current into the internal power MOSFETs. Connect the (+) terminal of the input capacitor as close as possible to the VIN pin, and connect the (-) terminal of the input capacitor as close as possible to the PGND pin. Care should be taken to minimize the loop area formed by the bypass capacitor connections, the VIN pins, and the power ground PGND connections.
- Since the LX connection is the switching node, the output inductor should be located close to the LX pin, and the area of the PCB conductor minimized to prevent excessive capacitive coupling. Keep the switching node, LX, away from all sensitive small-signal nodes.
- Connect V7V decoupling capacitor (connected close to the IC), between the V7V and the power ground PGND pin. This capacitor carries the MOSFET drivers' current peaks.
- Place the output filter capacitor of the buck converter close to SW_IN pins and AGND pin. Try to minimize the ground conductor length while maintaining adequate width.
- The AGND pin should be separately routed to the (-) terminal of V7V bypass capacitor to avoid switching grounding path. A ground plane is recommended connecting to this ground path.
- The compensation should be as close as possible to the COMP pins. The COMP and ROSC pins are sensitive to noise so the components associated to these pins should be located as close as possible to the IC and routed with minimal lengths of trace.
- Flood all unused areas on all layers with copper. Flooding with copper will reduce the temperature rise of the power components. You can connect the copper areas to PGND, AGND, VIN or any other DC rail in your system.
- There is no electric signal internal connected to thermal pad in the device. Nevertheless connect the exposed pad beneath the IC to ground. Always solder the thermal pad to the board, and have as many vias as possible on the PCB to enhance power dissipation.

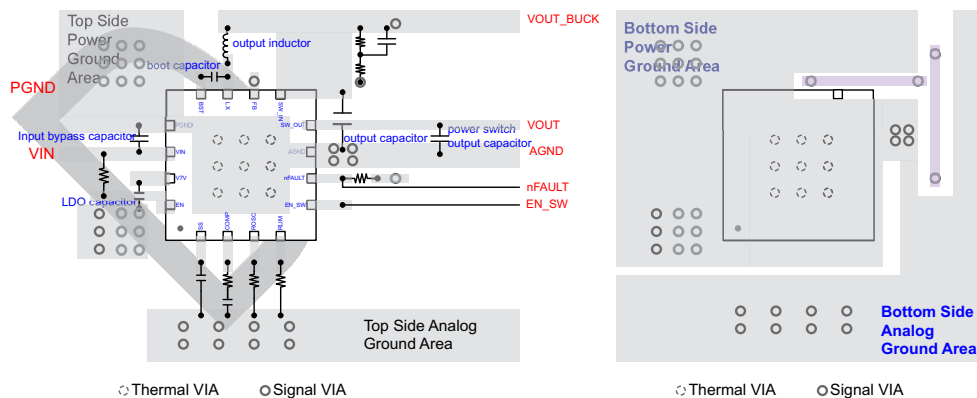

Figure 36. 2-Layers PCB Layout Recommendation Diagram

PACKAGING INFORMATION

Orderable Device	Status (1)	Package Type	Package Drawing	Pins	Package Qty	Eco Plan (2)	Lead/Ball Finish (6)	MSL Peak Temp (3)	Op Temp (°C)	Device Marking (4/5)	Samples
TPS65281-1RGVR	ACTIVE	VQFN	RGV	16	2500	Green (RoHS & no Sb/Br)	CU NIPDAU	Level-2-260C-1 YEAR	-40 to 125	TPS 65281-1	Samples
TPS65281RGVR	ACTIVE	VQFN	RGV	16	3000	Green (RoHS & no Sb/Br)	CU NIPDAU	Level-2-260C-1 YEAR	-40 to 125	TPS 65281	Samples
TPS65281RGVT	ACTIVE	VQFN	RGV	16	250	Green (RoHS & no Sb/Br)	CU NIPDAU	Level-2-260C-1 YEAR	-40 to 125	TPS 65281	Samples

(1) The marketing status values are defined as follows:

ACTIVE: Product device recommended for new designs.

LIFEBUY: TI has announced that the device will be discontinued, and a lifetime-buy period is in effect.

NRND: Not recommended for new designs. Device is in production to support existing customers, but TI does not recommend using this part in a new design.

PREVIEW: Device has been announced but is not in production. Samples may or may not be available.

OBsolete: TI has discontinued the production of the device.

(2) **RoHS:** TI defines "RoHS" to mean semiconductor products that are compliant with the current EU RoHS requirements for all 10 RoHS substances, including the requirement that RoHS substance do not exceed 0.1% by weight in homogeneous materials. Where designed to be soldered at high temperatures, "RoHS" products are suitable for use in specified lead-free processes. TI may reference these types of products as "Pb-Free".

RoHS Exempt: TI defines "RoHS Exempt" to mean products that contain lead but are compliant with EU RoHS pursuant to a specific EU RoHS exemption.

Green: TI defines "Green" to mean the content of Chlorine (Cl) and Bromine (Br) based flame retardants meet JS709B low halogen requirements of <=1000ppm threshold. Antimony trioxide based flame retardants must also meet the <=1000ppm threshold requirement.

(3) MSL, Peak Temp. - The Moisture Sensitivity Level rating according to the JEDEC industry standard classifications, and peak solder temperature.

(4) There may be additional marking, which relates to the logo, the lot trace code information, or the environmental category on the device.

(5) Multiple Device Markings will be inside parentheses. Only one Device Marking contained in parentheses and separated by a "-" will appear on a device. If a line is indented then it is a continuation of the previous line and the two combined represent the entire Device Marking for that device.

(6) Lead/Ball Finish - Orderable Devices may have multiple material finish options. Finish options are separated by a vertical ruled line. Lead/Ball Finish values may wrap to two lines if the finish value exceeds the maximum column width.

Important Information and Disclaimer: The information provided on this page represents TI's knowledge and belief as of the date that it is provided. TI bases its knowledge and belief on information provided by third parties, and makes no representation or warranty as to the accuracy of such information. Efforts are underway to better integrate information from third parties. TI has taken and continues to take reasonable steps to provide representative and accurate information but may not have conducted destructive testing or chemical analysis on incoming materials and chemicals. TI and TI suppliers consider certain information to be proprietary, and thus CAS numbers and other limited information may not be available for release.

In no event shall TI's liability arising out of such information exceed the total purchase price of the TI part(s) at issue in this document sold by TI to Customer on an annual basis.

TAPE AND REEL INFORMATION

QUADRANT ASSIGNMENTS FOR PIN 1 ORIENTATION IN TAPE

*All dimensions are nominal

Device	Package Type	Package Drawing	Pins	SPQ	Reel Diameter (mm)	Reel Width W1 (mm)	A0 (mm)	B0 (mm)	K0 (mm)	P1 (mm)	W (mm)	Pin1 Quadrant
TPS65281-1RGVR	VQFN	RGV	16	2500	330.0	12.4	4.25	4.25	1.15	8.0	12.0	Q2
TPS65281RGVR	VQFN	RGV	16	3000	330.0	12.4	4.25	4.25	1.15	8.0	12.0	Q2
TPS65281RGVT	VQFN	RGV	16	250	180.0	12.4	4.25	4.25	1.15	8.0	12.0	Q2

TAPE AND REEL BOX DIMENSIONS

*All dimensions are nominal

Device	Package Type	Package Drawing	Pins	SPQ	Length (mm)	Width (mm)	Height (mm)
TPS65281-1RGVR	VQFN	RGV	16	2500	367.0	367.0	35.0
TPS65281RGVR	VQFN	RGV	16	3000	367.0	367.0	35.0
TPS65281RGVT	VQFN	RGV	16	250	210.0	185.0	35.0

RGV (S-PVQFN-N16)

PLASTIC QUAD FLATPACK NO-LEAD

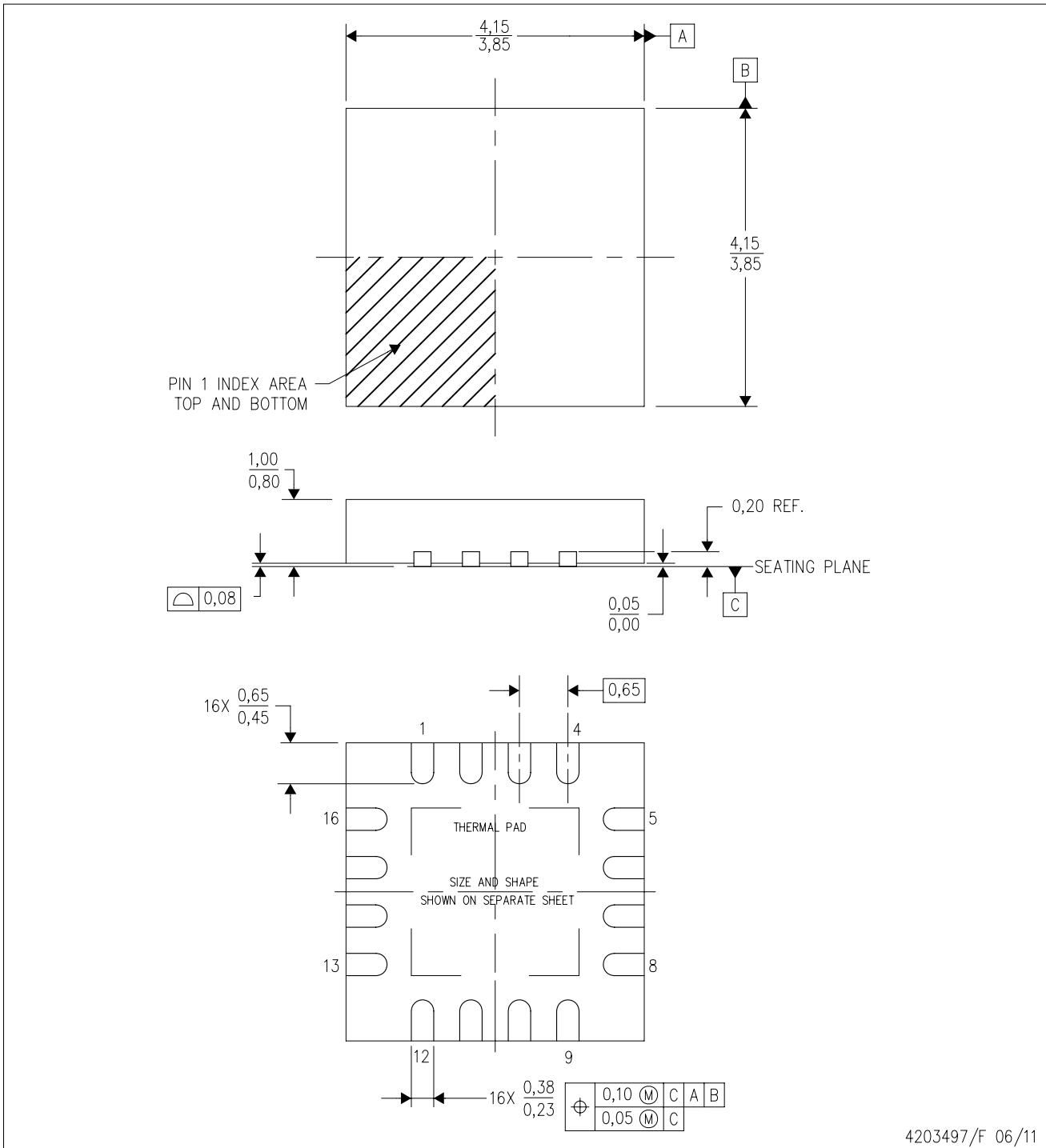

4203497/F 06/11

- NOTES:
- All linear dimensions are in millimeters. Dimensioning and tolerancing per ASME Y14.5M-1994.
 - This drawing is subject to change without notice.
 - Quad Flatpack, No-leads (QFN) package configuration.
 - The package thermal pad must be soldered to the board for thermal and mechanical performance.
 - See the additional figure in the Product Data Sheet for details regarding the exposed thermal pad features and dimensions.
 - Falls within JEDEC MO-220.

THERMAL PAD MECHANICAL DATA

RGV (S-PVQFN-N16)

PLASTIC QUAD FLATPACK NO-LEAD

THERMAL INFORMATION

This package incorporates an exposed thermal pad that is designed to be attached directly to an external heatsink. The thermal pad must be soldered directly to the printed circuit board (PCB). After soldering, the PCB can be used as a heatsink. In addition, through the use of thermal vias, the thermal pad can be attached directly to the appropriate copper plane shown in the electrical schematic for the device, or alternatively, can be attached to a special heatsink structure designed into the PCB. This design optimizes the heat transfer from the integrated circuit (IC).

For information on the Quad Flatpack No-Lead (QFN) package and its advantages, refer to Application Report, QFN/SON PCB Attachment, Texas Instruments Literature No. SLUA271. This document is available at www.ti.com.

The exposed thermal pad dimensions for this package are shown in the following illustration.

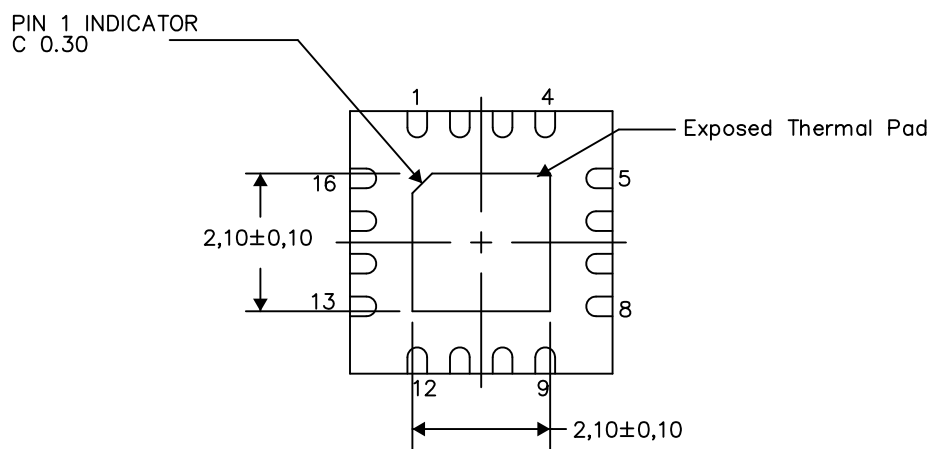

Bottom View

Exposed Thermal Pad Dimensions

4206351-3/L 05/13

NOTE: All linear dimensions are in millimeters

IMPORTANT NOTICE AND DISCLAIMER

TI PROVIDES TECHNICAL AND RELIABILITY DATA (INCLUDING DATASHEETS), DESIGN RESOURCES (INCLUDING REFERENCE DESIGNS), APPLICATION OR OTHER DESIGN ADVICE, WEB TOOLS, SAFETY INFORMATION, AND OTHER RESOURCES "AS IS" AND WITH ALL FAULTS, AND DISCLAIMS ALL WARRANTIES, EXPRESS AND IMPLIED, INCLUDING WITHOUT LIMITATION ANY IMPLIED WARRANTIES OF MERCHANTABILITY, FITNESS FOR A PARTICULAR PURPOSE OR NON-INFRINGEMENT OF THIRD PARTY INTELLECTUAL PROPERTY RIGHTS.

These resources are intended for skilled developers designing with TI products. You are solely responsible for (1) selecting the appropriate TI products for your application, (2) designing, validating and testing your application, and (3) ensuring your application meets applicable standards, and any other safety, security, or other requirements. These resources are subject to change without notice. TI grants you permission to use these resources only for development of an application that uses the TI products described in the resource. Other reproduction and display of these resources is prohibited. No license is granted to any other TI intellectual property right or to any third party intellectual property right. TI disclaims responsibility for, and you will fully indemnify TI and its representatives against, any claims, damages, costs, losses, and liabilities arising out of your use of these resources.

TI's products are provided subject to TI's Terms of Sale (www.ti.com/legal/termsofsale.html) or other applicable terms available either on ti.com or provided in conjunction with such TI products. TI's provision of these resources does not expand or otherwise alter TI's applicable warranties or warranty disclaimers for TI products.

Mailing Address: Texas Instruments, Post Office Box 655303, Dallas, Texas 75265
Copyright © 2018, Texas Instruments Incorporated

Looking for pricing, stock, or lifecycle information?

Click below to explore more details on WIN SOURCE:

 [View TPS65281RGVR on WIN SOURCE](#)

 [Texas Instruments](#) Information

Optimize Your Supply Chain with WIN SOURCE Solutions

-  Global Sourcing Solution
-  Obsolete Management
-  Cost Control Management
-  Shortage Management
-  Alternative Solution
-  Excess Inventory Management