



**THE DATASHEET OF
MC34063ADRG4**



MC3x063A 1.5-A Peak Boost/Buck/Inverting Switching Regulators

1 Features

- Wide Input Voltage Range: 3 V to 40 V
- High Output Switch Current: Up to 1.5 A
- Adjustable Output Voltage
- Oscillator Frequency Up to 100 kHz
- Precision Internal Reference: 2%
- Short-Circuit Current Limiting
- Low Standby Current

2 Applications

- Blood Gas Analyzers: Portable
- Cable Solutions
- HMIs (Human Machine Interfaces)
- Telecommunications
- Portable Devices
- Consumer & Computing
- Test & Measurement

3 Description

The MC33063A and MC34063A devices are easy-to-use ICs containing all the primary circuitry needed for building simple DC-DC converters. These devices primarily consist of an internal temperature-compensated reference, a comparator, an oscillator, a PWM controller with active current limiting, a driver, and a high-current output switch. Thus, the devices require minimal external components to build converters in the boost, buck, and inverting topologies.

The MC33063A device is characterized for operation from -40°C to 85°C , while the MC34063A device is characterized for operation from 0°C to 70°C .

Device Information⁽¹⁾

PART NUMBER	PACKAGE (PIN)	BODY SIZE
MC3x063A	SOIC (8)	4.90 mm x 3.91 mm
	SON (8)	4.00 mm x 4.00 mm
	PDIP (8)	9.81 mm x 6.35 mm

(1) For all available packages, see the orderable addendum at the end of the data sheet.

4 Simplified Schematic

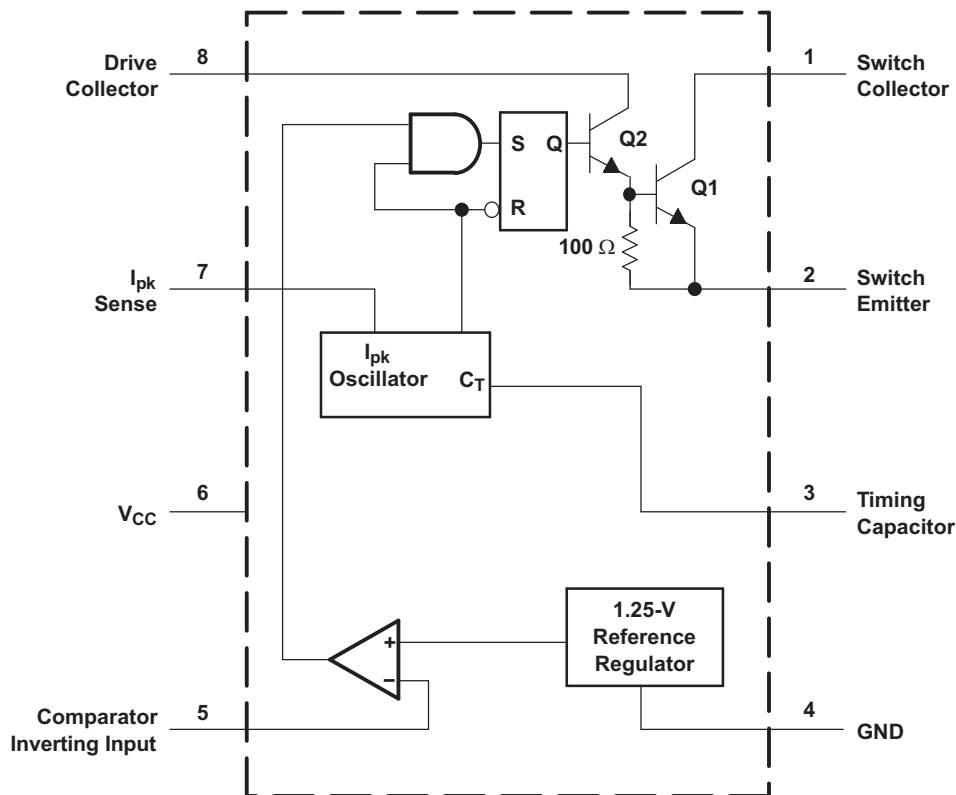

Table of Contents

1 Features	1	8.1 Overview	7
2 Applications	1	8.2 Functional Block Diagram	7
3 Description	1	8.3 Feature Description	7
4 Simplified Schematic	1	8.4 Device Functional Modes	7
5 Revision History	2	9 Application and Implementation	8
6 Pin Configuration and Functions	3	9.1 Application Information	8
7 Specifications	4	9.2 Typical Application	9
7.1 Absolute Maximum Ratings	4	10 Power Supply Recommendations	17
7.2 ESD Ratings	4	11 Layout	17
7.3 Recommended Operating Conditions	4	11.1 Layout Guidelines	17
7.4 Thermal Information	4	11.2 Layout Example	17
7.5 Electrical Characteristics—Oscillator	4	12 Device and Documentation Support	18
7.6 Electrical Characteristics—Output Switch	5	12.1 Related Links	18
7.7 Electrical Characteristics—Comparator	5	12.2 Trademarks	18
7.8 Electrical Characteristics—Total Device	5	12.3 Electrostatic Discharge Caution	18
7.9 Typical Characteristics	6	12.4 Glossary	18
8 Detailed Description	7	13 Mechanical, Packaging, and Orderable Information	18

5 Revision History

Changes from Revision M (January 2011) to Revision N

Page

<ul style="list-style-type: none"> Added <i>Applications</i>, <i>Device Information</i> table, <i>Pin Functions</i> table, <i>ESD Ratings</i> table, <i>Thermal Information</i> table, <i>Feature Description</i> section, <i>Device Functional Modes</i>, <i>Application and Implementation</i> section, <i>Power Supply Recommendations</i> section, <i>Layout</i> section, <i>Device and Documentation Support</i> section, and <i>Mechanical, Packaging, and Orderable Information</i> section. 	1
<ul style="list-style-type: none"> Deleted <i>Ordering Information</i> table. 	1

6 Pin Configuration and Functions

**D (SOIC) OR P (PDIP) PACKAGE
(TOP VIEW)**

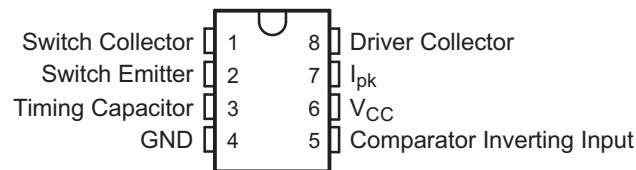

**DRJ (QFN) PACKAGE
(TOP VIEW)**

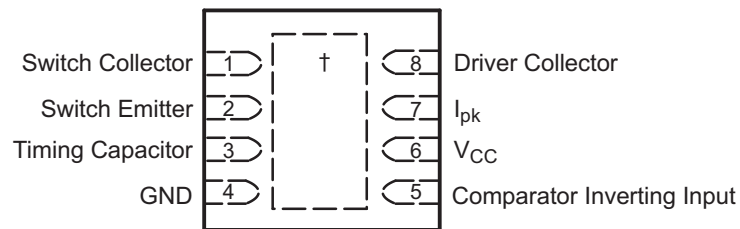

† The exposed thermal pad is electrically bonded internally to pin 4 (GND) .

Pin Functions

PIN		TYPE	DESCRIPTION
NAME	NO.		
Switch Collector	1	I/O	High-current internal switch collector input.
Switch Emitter	2	I/O	High-current internal switch emitter output.
Timing Capacitor	3	—	Attach a timing capacitor to change the switching frequency.
GND	4	—	Ground
Comparator Inverting Input	5	I	Attach to a resistor divider network to create a feedback loop.
V_{CC}	6	I	Logic supply voltage. Tie to V_{IN} .
I_{PK}	7	I	Current-limit sense input.
Driver Collector	8	I/O	Darlington pair driving transistor collector input.

7 Specifications

7.1 Absolute Maximum Ratings

over operating free-air temperature range (unless otherwise noted)⁽¹⁾

		MIN	MAX	UNIT
V _{CC}	Supply voltage		40	V
V _{IR}	Comparator inverting input voltage range	-0.3	40	V
V _{C(switch)}	Switch collector voltage		40	V
V _{E(switch)}	Switch emitter voltage		40	V
V _{CE(switch)}	Switch collector to switch emitter voltage		40	V
V _{C(driver)}	Driver collector voltage		40	V
I _{C(driver)}	Driver collector current		100	mA
I _{SW}	Switch current		1.5	A
T _J	Operating virtual junction temperature		150	°C
T _{stg}	Storage temperature range	-65	150	°C

(1) Stresses beyond those listed under *Absolute Maximum Ratings* may cause permanent damage to the device. These are stress ratings only, and functional operation of the device at these or any other conditions beyond those indicated under *Recommended Operating Conditions* is not implied. Exposure to absolute-maximum-rated conditions for extended periods may affect device reliability.

7.2 ESD Ratings

		VALUE	UNIT
V _(ESD)	Electrostatic discharge	Human body model (HBM), per ANSI/ESDA/JEDEC JS-001, all pins ⁽¹⁾	2500
		Charged device model (CDM), per JEDEC specification JESD22-C101, all pins ⁽²⁾	1500

(1) JEDEC document JEP155 states that 500-V HBM allows safe manufacturing with a standard ESD control process.

(2) JEDEC document JEP157 states that 250-V CDM allows safe manufacturing with a standard ESD control process.

7.3 Recommended Operating Conditions

		MIN	MAX	UNIT
V _{CC}	Supply voltage	3	40	V
T _A	Operating free-air temperature	MC33063A	-40	85
		MC34063A	0	70

7.4 Thermal Information

THERMAL METRIC ⁽¹⁾	MC33063A			UNIT	
	D	DRJ	P		
	8 PINS				
R _{θJA}	Junction-to-ambient thermal resistance	97	41	85	°C/W

(1) For more information about traditional and new thermal metrics, see the *IC Package Thermal Metrics* application report ([SPRA953](#)).

7.5 Electrical Characteristics—Oscillator

V_{CC} = 5 V, T_A = full operating range (unless otherwise noted) (see block diagram)

PARAMETER	TEST CONDITIONS	T _A	MIN	TYP	MAX	UNIT	
f _{osc}	Oscillator frequency	V _{PIN5} = 0 V, C _T = 1 nF	25°C	24	33	42	kHz
I _{chg}	Charge current	V _{CC} = 5 V to 40 V	25°C	24	35	42	μA
I _{dischg}	Discharge current	V _{CC} = 5 V to 40 V	25°C	140	220	260	μA
I _{dischg} /I _{chg}	Discharge-to-charge current ratio	V _{PIN7} = V _{CC}	25°C	5.2	6.5	7.5	—
V _{lpk}	Current-limit sense voltage	I _{dischg} = I _{chg}	25°C	250	300	350	mV

7.6 Electrical Characteristics—Output Switch

 $V_{CC} = 5\text{ V}$, $T_A =$ full operating range (unless otherwise noted) (see block diagram)⁽¹⁾

PARAMETER		TEST CONDITIONS	T_A	MIN	TYP	MAX	UNIT
$V_{CE(sat)}$	Saturation voltage – Darlington connection	$I_{SW} = 1\text{ A}$, pins 1 and 8 connected	Full range		1	1.3	V
$V_{CE(sat)}$	Saturation voltage – non-Darlington connection ⁽²⁾	$I_{SW} = 1\text{ A}$, $R_{PIN8} = 82\ \Omega$ to V_{CC} , forced $\beta \sim 20$	Full range		0.45	0.7	V
h_{FE}	DC current gain	$I_{SW} = 1\text{ A}$, $V_{CE} = 5\text{ V}$	25°C	50	75		—
$I_{C(off)}$	Collector off-state current	$V_{CE} = 40\text{ V}$	Full range		0.01	100	μA

(1) Low duty-cycle pulse testing is used to maintain junction temperature as close to ambient temperature as possible.

(2) In the non-Darlington configuration, if the output switch is driven into hard saturation at low switch currents ($\leq 300\text{ mA}$) and high driver currents ($\geq 30\text{ mA}$), it may take up to $2\ \mu\text{s}$ for the switch to come out of saturation. This condition effectively shortens the off time at frequencies $\geq 30\text{ kHz}$, becoming magnified as temperature increases. The following output drive condition is recommended in the non-Darlington configuration:

Forced β of output switch = $I_{C,SW} / (I_{C,driver} - 7\text{ mA}) \geq 10$, where $\sim 7\text{ mA}$ is required by the $100\text{-}\Omega$ resistor in the emitter of the driver to forward bias the V_{be} of the switch.

7.7 Electrical Characteristics—Comparator

 $V_{CC} = 5\text{ V}$, $T_A =$ full operating range (unless otherwise noted) (see block diagram)

PARAMETER		TEST CONDITIONS	T_A	MIN	TYP	MAX	UNIT
V_{th}	Threshold voltage		25°C	1.225	1.25	1.275	V
			Full range	1.21		1.29	
ΔV_{th}	Threshold-voltage line regulation	$V_{CC} = 5\text{ V}$ to 40 V	Full range		1.4	5	mV
I_{IB}	Input bias current	$V_{IN} = 0\text{ V}$	Full range		-20	-400	nA

7.8 Electrical Characteristics—Total Device

 $V_{CC} = 5\text{ V}$, $T_A =$ full operating range (unless otherwise noted) (see block diagram)

PARAMETER		TEST CONDITIONS	T_A	MIN	MAX	UNIT
I_{CC}	Supply current	$V_{CC} = 5\text{ V}$ to 40 V , $C_T = 1\text{ nF}$, $V_{PIN7} = V_{CC}$, $V_{PIN5} > V_{th}$, $V_{PIN2} = \text{GND}$, All other pins open	Full range		4	mA

7.9 Typical Characteristics

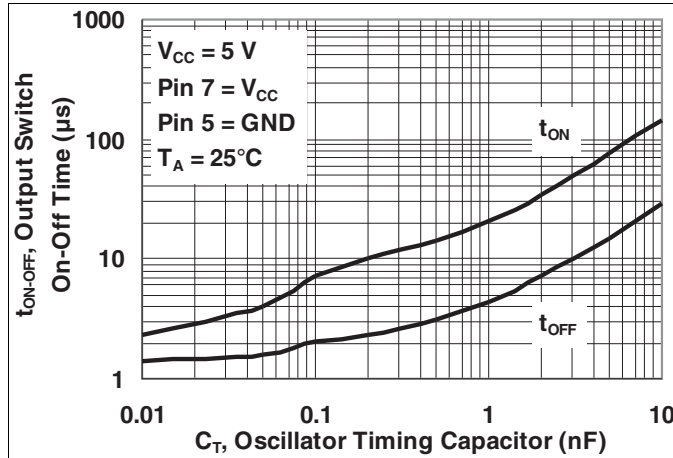

Figure 1. Output Switch On-Off Time vs Oscillator Timing Capacitor

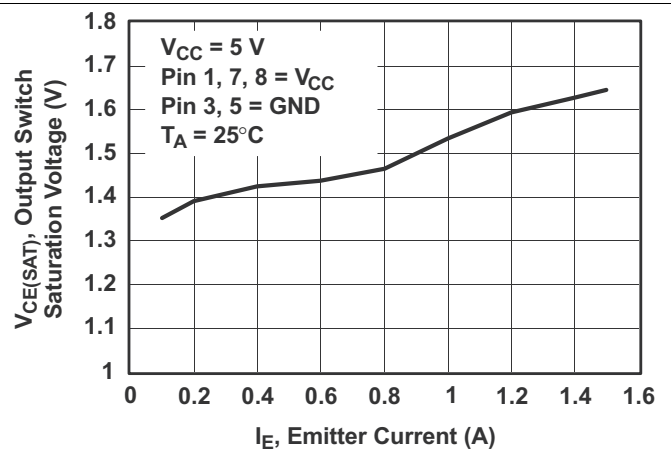

Figure 2. Output Switch Saturation Voltage vs Emitter Current (Emitter-Follower Configuration)

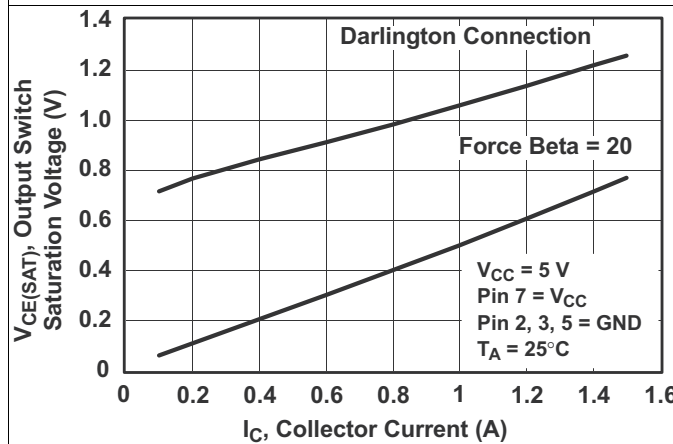

Figure 3. Output Switch Saturation Voltage vs Collector Current (Common-Emitter Configuration)

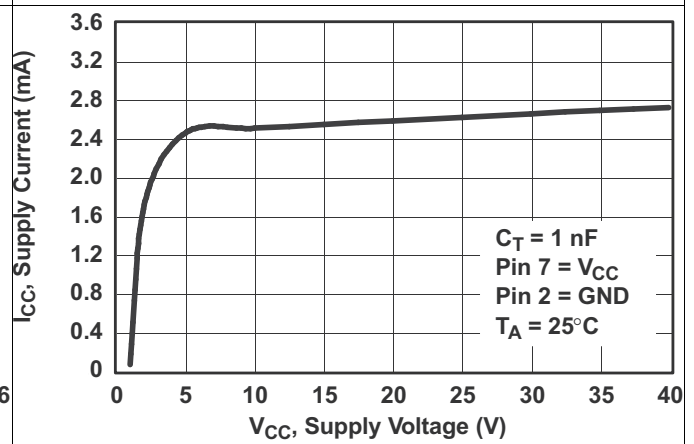

Figure 4. Standby Supply Current vs Supply Voltage

8 Detailed Description

8.1 Overview

The MC33063A and MC34063A devices are easy-to-use ICs containing all the primary circuitry needed for building simple DC-DC converters. These devices primarily consist of an internal temperature-compensated reference, a comparator, an oscillator, a PWM controller with active current limiting, a driver, and a high-current output switch. Thus, the devices require minimal external components to build converters in the boost, buck, and inverting topologies.

The MC33063A device is characterized for operation from -40°C to 85°C , while the MC34063A device is characterized for operation from 0°C to 70°C .

8.2 Functional Block Diagram

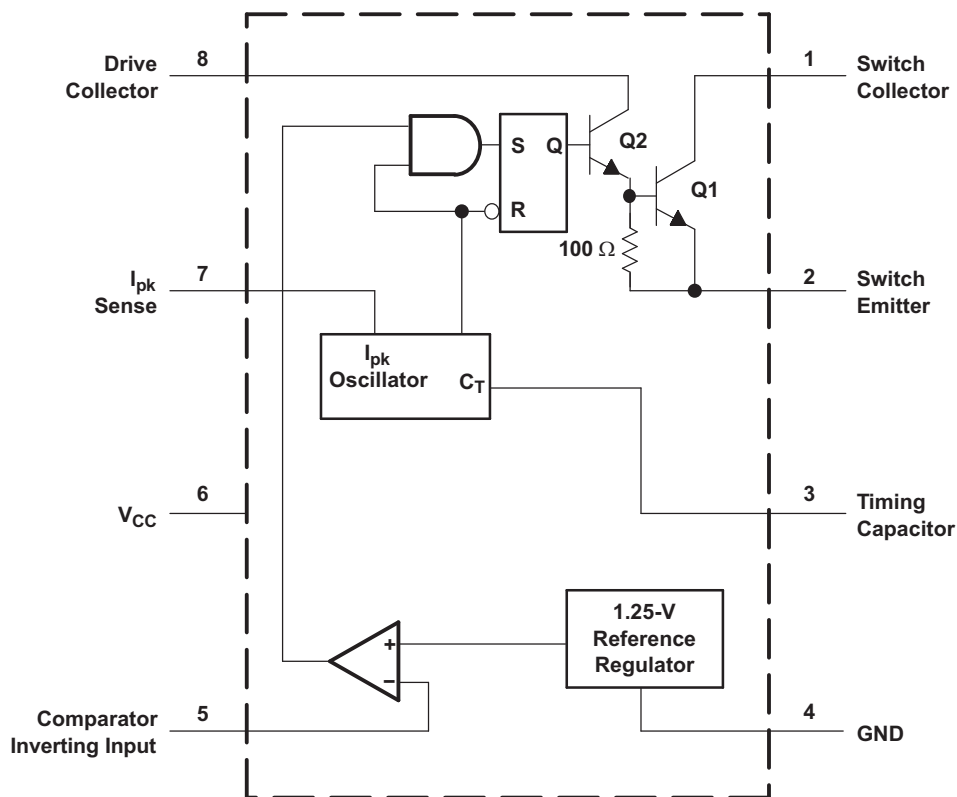

8.3 Feature Description

- Wide Input Voltage Range: 3 V to 40 V
- High Output Switch Current: Up to 1.5 A
- Adjustable Output Voltage
- Oscillator Frequency Up to 100 kHz
- Precision Internal Reference: 2%
- Short-Circuit Current Limiting
- Low Standby Current

8.4 Device Functional Modes

8.4.1 Standard operation

Based on the application, the device can be configured in multiple different topologies. See the [Application and Implementation](#) section for how to configure the device in several different operating modes.

9 Application and Implementation

NOTE

Information in the following applications sections is not part of the TI component specification, and TI does not warrant its accuracy or completeness. TI's customers are responsible for determining suitability of components for their purposes. Customers should validate and test their design implementation to confirm system functionality.

9.1 Application Information

9.1.1 External Switch Configurations for Higher Peak Current

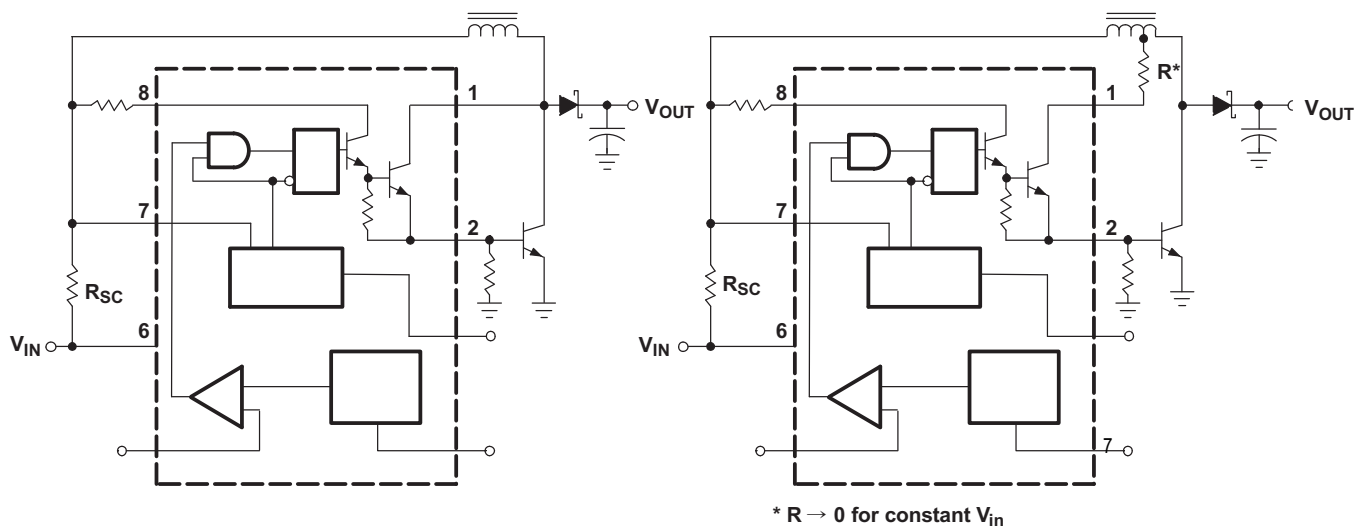

a) EXTERNAL npn SWITCH

b) EXTERNAL npn SATURATED SWITCH (see Note A)

- A. If the output switch is driven into hard saturation (non-Darlington configuration) at low switch currents (≤ 300 mA) and high driver currents (≥ 30 mA), it may take up to $2 \mu\text{s}$ to come out of saturation. This condition will shorten the off time at frequencies ≥ 30 kHz and is magnified at high temperatures. This condition does not occur with a Darlington configuration because the output switch cannot saturate. If a non-Darlington configuration is used, the output drive configuration in Figure 7b is recommended.

Figure 5. Boost Regulator Connections for I_C Peak Greater Than 1.5 A

Application Information (continued)

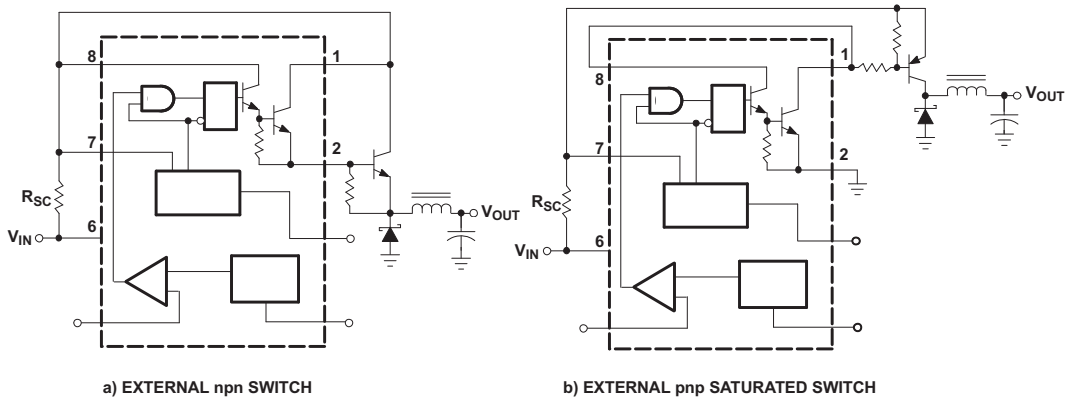

Figure 6. Buck Regulator Connections for I_C Peak Greater Than 1.5 A

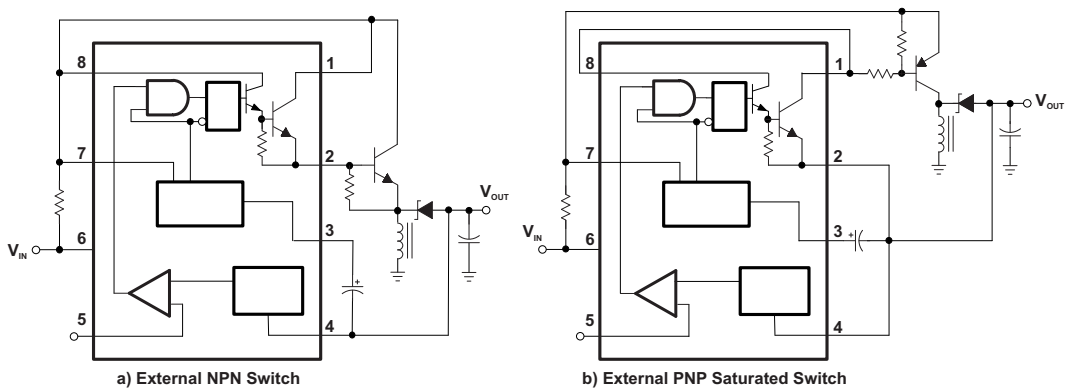
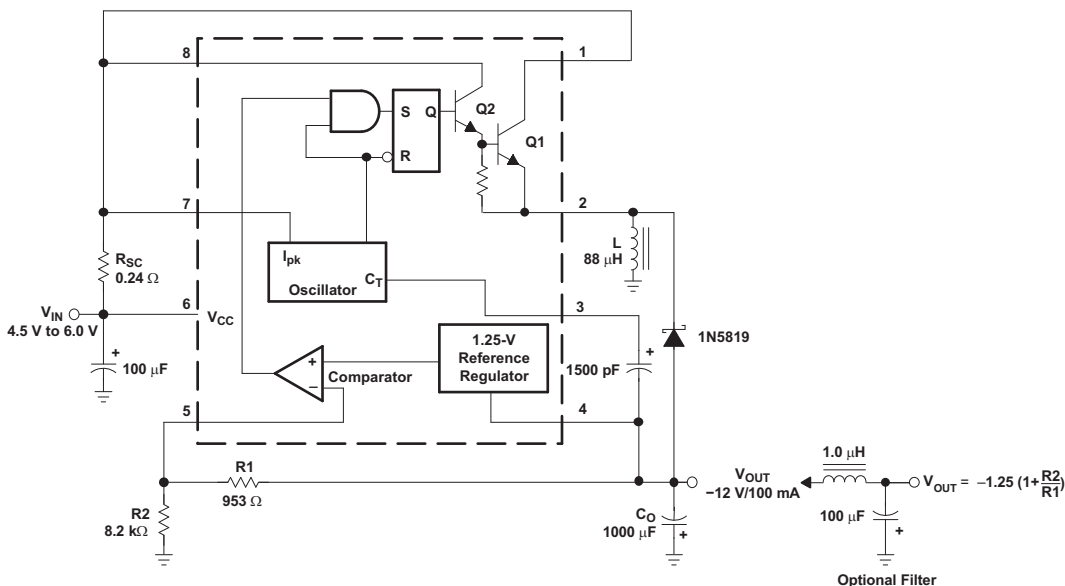

Figure 7. Inverting Regulator Connections for I_C Peak Greater Than 1.5 A

9.2 Typical Application

9.2.1 Voltage-Inverting Converter Application



Typical Application (continued)**Figure 8. Voltage-Inverting Converter**

Typical Application (continued)

9.2.1.1 Design Requirements

The user must determine the following desired parameters:

V_{sat} = Saturation voltage of the output switch

V_F = Forward voltage drop of the chosen output rectifier

The following power-supply parameters are set by the user:

V_{in} = Nominal input voltage

V_{out} = Desired output voltage

I_{out} = Desired output current

f_{min} = Minimum desired output switching frequency at the selected values of V_{in} and I_{out}

V_{ripple} = Desired peak-to-peak output ripple voltage. The ripple voltage directly affects the line and load regulation and, thus, must be considered. In practice, the actual capacitor value should be larger than the calculated value, to account for the capacitor's equivalent series resistance and board layout.

9.2.1.2 Detailed Design Procedure

CALCULATION	VOLTAGE INVERTING
t_{on}/t_{off}	$\frac{ V_{out} + V_F}{V_{in} - V_{sat}}$
$(t_{on} + t_{off})$	$\frac{1}{f}$
t_{off}	$\frac{t_{on} + t_{off}}{\frac{t_{on}}{t_{off}} + 1}$
t_{on}	$(t_{on} + t_{off}) - t_{off}$
C_T	$4 \times 10^{-5} t_{on}$
$I_{pk(switch)}$	$2I_{out(max)} \left(\frac{t_{on}}{t_{off}} + 1 \right)$
R_{SC}	$\frac{0.3}{I_{pk(switch)}}$
$L_{(min)}$	$\left(\frac{(V_{in(min)} - V_{sat})}{I_{pk(switch)}} \right) t_{on(max)}$
C_O	$9 \frac{I_{out} t_{on}}{V_{ripple(pp)}}$
V_{out}	$-1.25 \left(1 + \frac{R2}{R1} \right)$ See Figure 8

9.2.1.3 Application Performance

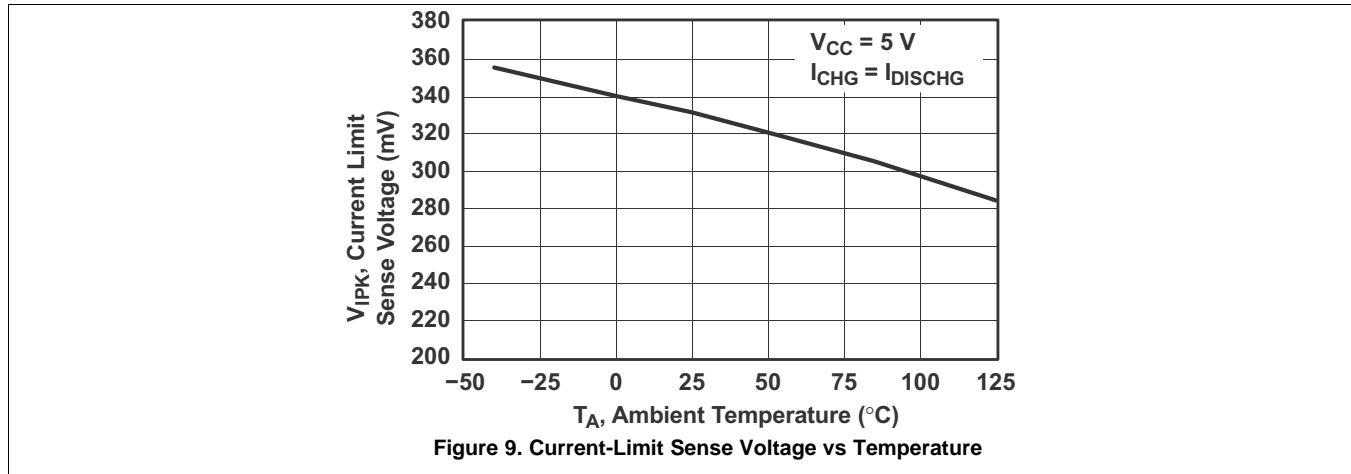

TEST	CONDITIONS	RESULTS
Line regulation	$V_{IN} = 4.5 \text{ V to } 6 \text{ V}, I_O = 100 \text{ mA}$	$3 \text{ mV} \pm 0.12\%$
Load regulation	$V_{IN} = 5 \text{ V}, I_O = 10 \text{ mA to } 100 \text{ mA}$	$0.022 \text{ V} \pm 0.09\%$
Output ripple	$V_{IN} = 5 \text{ V}, I_O = 100 \text{ mA}$	500 mV_{PP}
Short-circuit current	$V_{IN} = 5 \text{ V}, R_L = 0.1 \Omega$	910 mA
Efficiency	$V_{IN} = 5 \text{ V}, I_O = 100 \text{ mA}$	62.2%
Output ripple with optional filter	$V_{IN} = 5 \text{ V}, I_O = 100 \text{ mA}$	70 mV_{PP}

9.2.2 Step-Up Converter Application

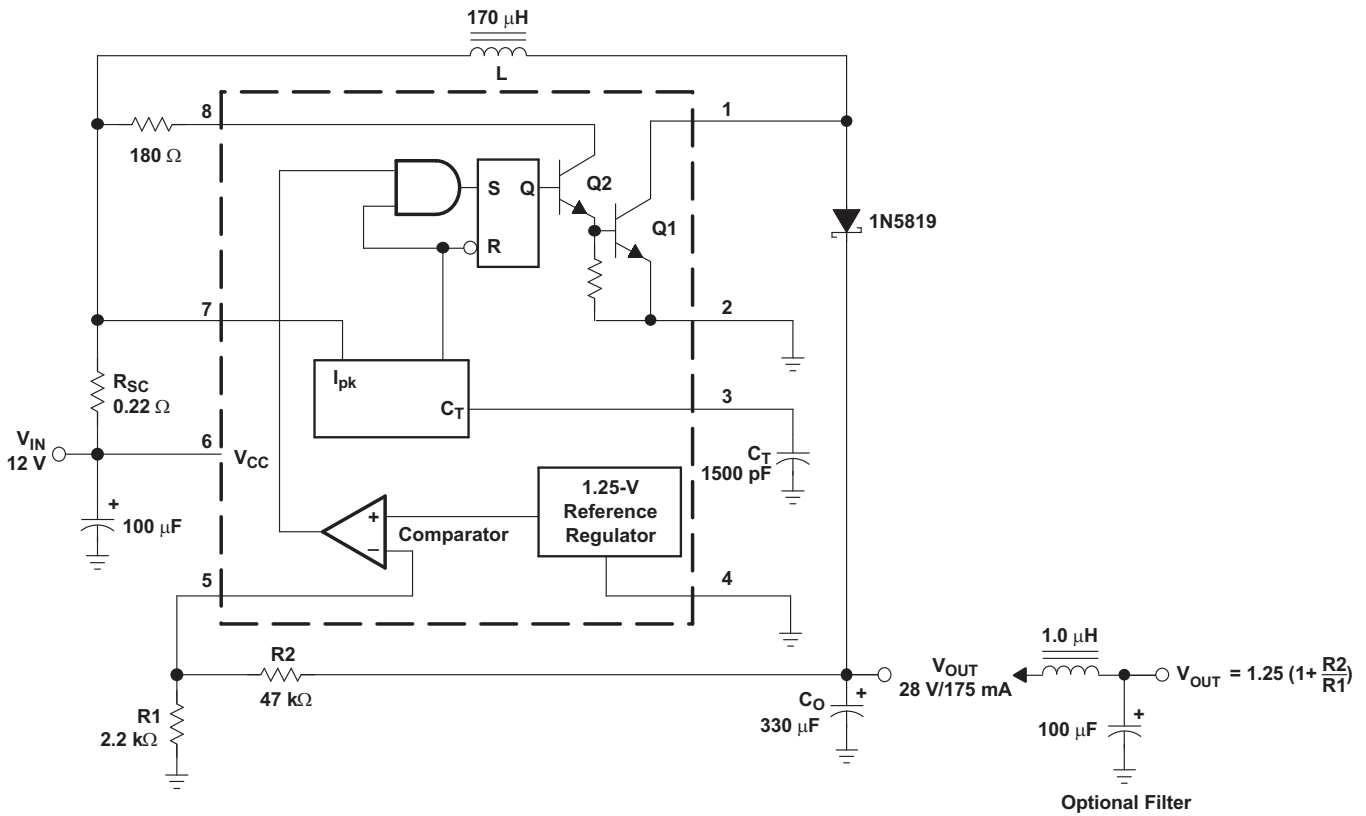

Figure 10. Step-Up Converter

9.2.2.1 Design Requirements

The user must determine the following desired parameters:

V_{sat} = Saturation voltage of the output switch

V_F = Forward voltage drop of the chosen output rectifier

The following power-supply parameters are set by the user:

V_{in} = Nominal input voltage

V_{out} = Desired output voltage

I_{out} = Desired output current

f_{min} = Minimum desired output switching frequency at the selected values of V_{in} and I_{out}

V_{ripple} = Desired peak-to-peak output ripple voltage. The ripple voltage directly affects the line and load regulation and, thus, must be considered. In practice, the actual capacitor value should be larger than the calculated value, to account for the capacitor's equivalent series resistance and board layout.

9.2.2.2 Detailed Design Procedure

CALCULATION	STEP UP
t_{on}/t_{off}	$\frac{V_{out} + V_{F-Vin(min)}}{V_{in(min)} - V_{sat}}$
$(t_{on} + t_{off})$	$\frac{1}{f}$
t_{off}	$\frac{t_{on} + t_{off}}{\frac{t_{on}}{t_{off}} + 1}$
t_{on}	$(t_{on} + t_{off}) - t_{off}$
C_T	$4 \times 10^{-5} t_{on}$
$I_{pk(switch)}$	$2I_{out(max)} \left(\frac{t_{on}}{t_{off}} + 1 \right)$
R_{SC}	$\frac{0.3}{I_{pk(switch)}}$
$L_{(min)}$	$\left(\frac{(V_{in(min)} - V_{sat})}{I_{pk(switch)}} \right) t_{on(max)}$
C_O	$9 \frac{I_{out} t_{on}}{V_{ripple(pp)}}$
V_{out}	$1.25 \left(1 + \frac{R2}{R1} \right)$ See Figure 10

9.2.2.3 Application Performance

TEST	CONDITIONS	RESULTS
Line regulation	$V_{IN} = 8\text{ V to }16\text{ V}, I_O = 175\text{ mA}$	$30\text{ mV} \pm 0.05\%$
Load regulation	$V_{IN} = 12\text{ V}, I_O = 75\text{ mA to }175\text{ mA}$	$10\text{ mV} \pm 0.017\%$
Output ripple	$V_{IN} = 12\text{ V}, I_O = 175\text{ mA}$	400 mV_{PP}
Efficiency	$V_{IN} = 12\text{ V}, I_O = 175\text{ mA}$	87.7%
Output ripple with optional filter	$V_{IN} = 12\text{ V}, I_O = 175\text{ mA}$	40 mV_{PP}

9.2.3 Step-Down Converter Application

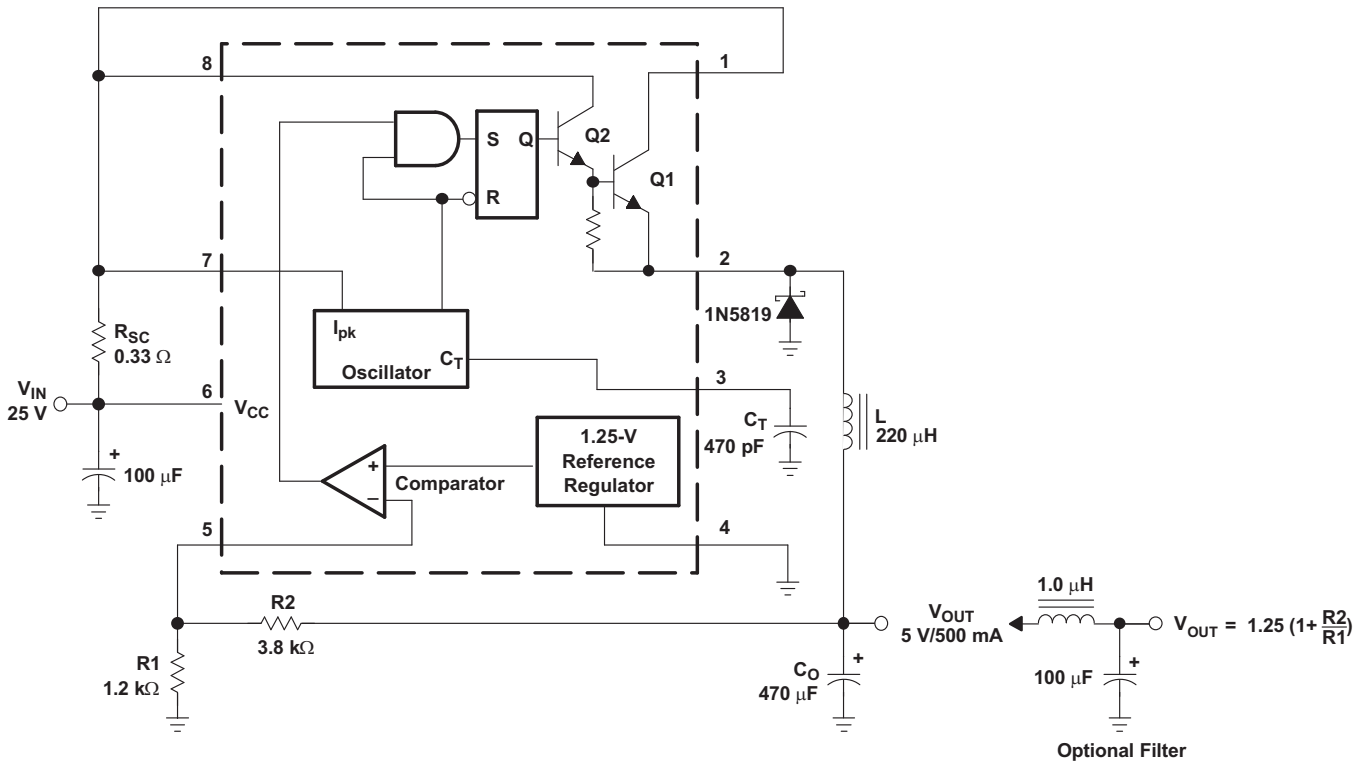

Figure 11. Step-Down Converter

9.2.3.1 Design Requirements

The user must determine the following desired parameters:

V_{sat} = Saturation voltage of the output switch

V_F = Forward voltage drop of the chosen output rectifier

The following power-supply parameters are set by the user:

V_{in} = Nominal input voltage

V_{out} = Desired output voltage

I_{out} = Desired output current

f_{min} = Minimum desired output switching frequency at the selected values of V_{in} and I_{out}

V_{ripple} = Desired peak-to-peak output ripple voltage. The ripple voltage directly affects the line and load regulation and, thus, must be considered. In practice, the actual capacitor value should be larger than the calculated value, to account for the capacitor's equivalent series resistance and board layout.

9.2.3.2 Detailed Design Procedure

CALCULATION	STEP DOWN
t_{on}/t_{off}	$\frac{V_{out} + V_F}{V_{in(min)} - V_{sat} - V_{out}}$
$(t_{on} + t_{off})$	$\frac{1}{f}$
t_{off}	$\frac{t_{on} + t_{off}}{\frac{t_{on}}{t_{off}} + 1}$
t_{on}	$(t_{on} + t_{off}) - t_{off}$
C_T	$4 \times 10^{-5} t_{on}$
$I_{pk(switch)}$	$2I_{out(max)}$
R_{SC}	$\frac{0.3}{I_{pk(switch)}}$
$L_{(min)}$	$\left(\frac{(V_{in(min)} - V_{sat} - V_{out})}{I_{pk(switch)}} \right) t_{on(max)}$
C_O	$\frac{I_{pk(switch)} (t_{on} + t_{off})}{8V_{ripple(pp)}}$
V_{out}	$1.25 \left(1 + \frac{R_2}{R_1} \right)$ See Figure 11

9.2.3.3 Application Performance

TEST	CONDITIONS	RESULTS
Line regulation	$V_{IN} = 15 \text{ V to } 25 \text{ V}, I_O = 500 \text{ mA}$	$12 \text{ mV} \pm 0.12\%$
Load regulation	$V_{IN} = 25 \text{ V}, I_O = 50 \text{ mA to } 500 \text{ mA}$	$3 \text{ mV} \pm 0.03\%$
Output ripple	$V_{IN} = 25 \text{ V}, I_O = 500 \text{ mA}$	120 mV_{PP}
Short-circuit current	$V_{IN} = 25 \text{ V}, R_L = 0.1 \Omega$	1.1 A
Efficiency	$V_{IN} = 25 \text{ V}, I_O = 500 \text{ mA}$	83.7%
Output ripple with optional filter	$V_{IN} = 25 \text{ V}, I_O = 500 \text{ mA}$	40 mV_{PP}

10 Power Supply Recommendations

This device accepts 3 V to 40 V on the input. It is recommended to have a 1000- μ F decoupling capacitor on the input.

11 Layout

11.1 Layout Guidelines

Keep feedback loop layout trace lengths to a minimum to avoid unnecessary IR drop. In addition, the loop for the decoupling capacitor at the input should be as small as possible. The trace from V_{IN} to pin 1 of the device should be thicker to handle the higher current.

11.2 Layout Example

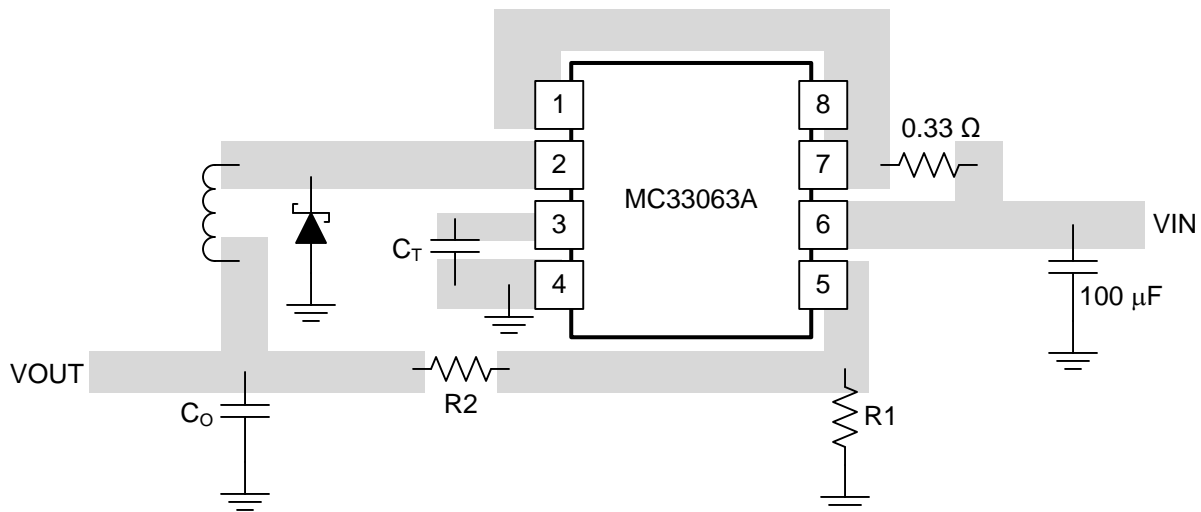

Figure 12. Layout Example for a Step-Down Converter

12 Device and Documentation Support

12.1 Related Links

The table below lists quick access links. Categories include technical documents, support and community resources, tools and software, and quick access to sample or buy.

Table 1. Related Links

PARTS	PRODUCT FOLDER	SAMPLE & BUY	TECHNICAL DOCUMENTS	TOOLS & SOFTWARE	SUPPORT & COMMUNITY
MC33063A	Click here	Click here	Click here	Click here	Click here
MC34063A	Click here	Click here	Click here	Click here	Click here

12.2 Trademarks

All trademarks are the property of their respective owners.

12.3 Electrostatic Discharge Caution



These devices have limited built-in ESD protection. The leads should be shorted together or the device placed in conductive foam during storage or handling to prevent electrostatic damage to the MOS gates.

12.4 Glossary

[SLYZ022](#) — *TI Glossary*.

This glossary lists and explains terms, acronyms, and definitions.

13 Mechanical, Packaging, and Orderable Information

The following pages include mechanical, packaging, and orderable information. This information is the most current data available for the designated devices. This data is subject to change without notice and revision of this document. For browser-based versions of this data sheet, refer to the left-hand navigation.

PACKAGING INFORMATION

Orderable Device	Status (1)	Package Type	Package Drawing	Pins	Package Qty	Eco Plan (2)	Lead/Ball Finish (6)	MSL Peak Temp (3)	Op Temp (°C)	Device Marking (4/5)	Samples
MC33063AD	ACTIVE	SOIC	D	8	75	Green (RoHS & no Sb/Br)	CU NIPDAU	Level-1-260C-UNLIM	-40 to 85	M33063A	Samples
MC33063ADE4	ACTIVE	SOIC	D	8	75	Green (RoHS & no Sb/Br)	CU NIPDAU	Level-1-260C-UNLIM	-40 to 85	M33063A	Samples
MC33063ADG4	ACTIVE	SOIC	D	8	75	Green (RoHS & no Sb/Br)	CU NIPDAU	Level-1-260C-UNLIM	-40 to 85	M33063A	Samples
MC33063ADR	ACTIVE	SOIC	D	8	2500	Green (RoHS & no Sb/Br)	CU NIPDAU	Level-1-260C-UNLIM	-40 to 85	M33063A	Samples
MC33063ADRE4	ACTIVE	SOIC	D	8	2500	Green (RoHS & no Sb/Br)	CU NIPDAU	Level-1-260C-UNLIM	-40 to 85	M33063A	Samples
MC33063ADRG4	ACTIVE	SOIC	D	8	2500	Green (RoHS & no Sb/Br)	CU NIPDAU	Level-1-260C-UNLIM	-40 to 85	M33063A	Samples
MC33063ADRJR	ACTIVE	SON	DRJ	8	1000	Green (RoHS & no Sb/Br)	CU NIPDAU	Level-3-260C-168 HR	-40 to 85	ZYF	Samples
MC33063AP	ACTIVE	PDIP	P	8	50	Green (RoHS & no Sb/Br)	CU NIPDAU	N / A for Pkg Type	-40 to 85	MC33063AP	Samples
MC33063APE4	ACTIVE	PDIP	P	8	50	Green (RoHS & no Sb/Br)	CU NIPDAU	N / A for Pkg Type	-40 to 85	MC33063AP	Samples
MC34063AD	ACTIVE	SOIC	D	8	75	Green (RoHS & no Sb/Br)	CU NIPDAU	Level-1-260C-UNLIM	0 to 70	M34063A	Samples
MC34063ADE4	ACTIVE	SOIC	D	8	75	Green (RoHS & no Sb/Br)	CU NIPDAU	Level-1-260C-UNLIM	0 to 70	M34063A	Samples
MC34063ADG4	ACTIVE	SOIC	D	8	75	Green (RoHS & no Sb/Br)	CU NIPDAU	Level-1-260C-UNLIM	0 to 70	M34063A	Samples
MC34063ADR	ACTIVE	SOIC	D	8	2500	Green (RoHS & no Sb/Br)	CU NIPDAU	Level-1-260C-UNLIM	0 to 70	M34063A	Samples
MC34063ADRJR	ACTIVE	SON	DRJ	8	1000	Green (RoHS & no Sb/Br)	CU NIPDAU	Level-3-260C-168 HR	0 to 70	ZYF	Samples
MC34063ADRJRG4	ACTIVE	SON	DRJ	8	1000	Green (RoHS & no Sb/Br)	CU NIPDAU	Level-3-260C-168 HR	0 to 70	ZYF	Samples
MC34063AP	ACTIVE	PDIP	P	8	50	Green (RoHS & no Sb/Br)	CU NIPDAU	N / A for Pkg Type	0 to 70	MC34063AP	Samples
MC34063APE4	ACTIVE	PDIP	P	8	50	Green (RoHS & no Sb/Br)	CU NIPDAU	N / A for Pkg Type	0 to 70	MC34063AP	Samples

(1) The marketing status values are defined as follows:

ACTIVE: Product device recommended for new designs.

LIFEBUY: TI has announced that the device will be discontinued, and a lifetime-buy period is in effect.

NRND: Not recommended for new designs. Device is in production to support existing customers, but TI does not recommend using this part in a new design.

PREVIEW: Device has been announced but is not in production. Samples may or may not be available.

OBSOLETE: TI has discontinued the production of the device.

(2) **RoHS:** TI defines "RoHS" to mean semiconductor products that are compliant with the current EU RoHS requirements for all 10 RoHS substances, including the requirement that RoHS substance do not exceed 0.1% by weight in homogeneous materials. Where designed to be soldered at high temperatures, "RoHS" products are suitable for use in specified lead-free processes. TI may reference these types of products as "Pb-Free".

RoHS Exempt: TI defines "RoHS Exempt" to mean products that contain lead but are compliant with EU RoHS pursuant to a specific EU RoHS exemption.

Green: TI defines "Green" to mean the content of Chlorine (Cl) and Bromine (Br) based flame retardants meet JS709B low halogen requirements of ≤ 1000 ppm threshold. Antimony trioxide based flame retardants must also meet the ≤ 1000 ppm threshold requirement.

(3) MSL, Peak Temp. - The Moisture Sensitivity Level rating according to the JEDEC industry standard classifications, and peak solder temperature.

(4) There may be additional marking, which relates to the logo, the lot trace code information, or the environmental category on the device.

(5) Multiple Device Markings will be inside parentheses. Only one Device Marking contained in parentheses and separated by a "~" will appear on a device. If a line is indented then it is a continuation of the previous line and the two combined represent the entire Device Marking for that device.

(6) Lead/Ball Finish - Orderable Devices may have multiple material finish options. Finish options are separated by a vertical ruled line. Lead/Ball Finish values may wrap to two lines if the finish value exceeds the maximum column width.

Important Information and Disclaimer: The information provided on this page represents TI's knowledge and belief as of the date that it is provided. TI bases its knowledge and belief on information provided by third parties, and makes no representation or warranty as to the accuracy of such information. Efforts are underway to better integrate information from third parties. TI has taken and continues to take reasonable steps to provide representative and accurate information but may not have conducted destructive testing or chemical analysis on incoming materials and chemicals. TI and TI suppliers consider certain information to be proprietary, and thus CAS numbers and other limited information may not be available for release.

In no event shall TI's liability arising out of such information exceed the total purchase price of the TI part(s) at issue in this document sold by TI to Customer on an annual basis.

OTHER QUALIFIED VERSIONS OF MC33063A :

- Automotive: [MC33063A-Q1](#)

NOTE: Qualified Version Definitions:

- Automotive - Q100 devices qualified for high-reliability automotive applications targeting zero defects

TAPE AND REEL INFORMATION

QUADRANT ASSIGNMENTS FOR PIN 1 ORIENTATION IN TAPE

*All dimensions are nominal

Device	Package Type	Package Drawing	Pins	SPQ	Reel Diameter (mm)	Reel Width W1 (mm)	A0 (mm)	B0 (mm)	K0 (mm)	P1 (mm)	W (mm)	Pin1 Quadrant
MC33063ADR	SOIC	D	8	2500	330.0	12.4	6.4	5.2	2.1	8.0	12.0	Q1
MC33063ADR	SOIC	D	8	2500	330.0	12.4	6.4	5.2	2.1	8.0	12.0	Q1
MC33063ADRJR	SON	DRJ	8	1000	330.0	12.4	4.25	4.25	1.15	8.0	12.0	Q2
MC34063ADR	SOIC	D	8	2500	330.0	12.4	6.4	5.2	2.1	8.0	12.0	Q1
MC34063ADRJR	SON	DRJ	8	1000	180.0	12.4	4.25	4.25	1.15	8.0	12.0	Q2

TAPE AND REEL BOX DIMENSIONS

*All dimensions are nominal

Device	Package Type	Package Drawing	Pins	SPQ	Length (mm)	Width (mm)	Height (mm)
MC33063ADR	SOIC	D	8	2500	367.0	367.0	35.0
MC33063ADR	SOIC	D	8	2500	340.5	338.1	20.6
MC33063ADRJR	SON	DRJ	8	1000	367.0	367.0	35.0
MC34063ADR	SOIC	D	8	2500	340.5	338.1	20.6
MC34063ADRJR	SON	DRJ	8	1000	210.0	185.0	35.0

DRJ (S-PWSON-N8)

PLASTIC SMALL OUTLINE NO-LEAD

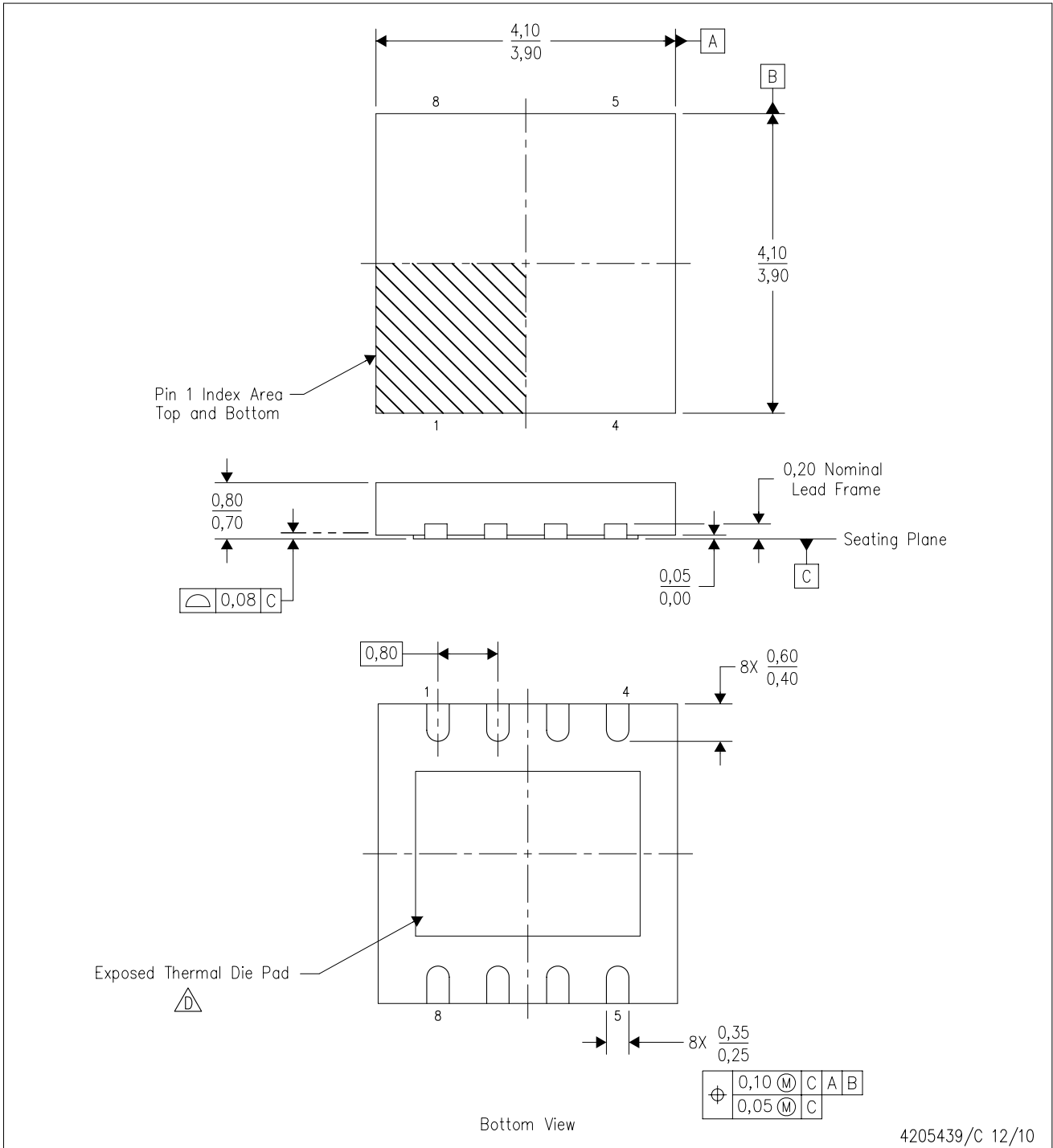

4205439/C 12/10

- NOTES:
- A. All linear dimensions are in millimeters. Dimensioning and tolerancing per ASME Y14.5M-1994.
 - B. This drawing is subject to change without notice.
 - C. SON (Small Outline No-Lead) package configuration.
 -  The package thermal pad must be soldered to the board for thermal and mechanical performance. See the Product Data Sheet for details regarding the exposed thermal pad dimensions.
 - E. Package complies to JEDEC MO-229 variation WGGB.

THERMAL PAD MECHANICAL DATA

DRJ (S-PWSON-N8)

PLASTIC SMALL OUTLINE NO-LEAD

THERMAL INFORMATION

This package incorporates an exposed thermal pad that is designed to be attached directly to an external heatsink. The thermal pad must be soldered directly to the printed circuit board (PCB). After soldering, the PCB can be used as a heatsink. In addition, through the use of thermal vias, the thermal pad can be attached directly to the appropriate copper plane shown in the electrical schematic for the device, or alternatively, can be attached to a special heatsink structure designed into the PCB. This design optimizes the heat transfer from the integrated circuit (IC).

For information on the Quad Flatpack No-Lead (QFN) package and its advantages, refer to Application Report, QFN/SON PCB Attachment, Texas Instruments Literature No. SLUA271. This document is available at www.ti.com.

The exposed thermal pad dimensions for this package are shown in the following illustration.

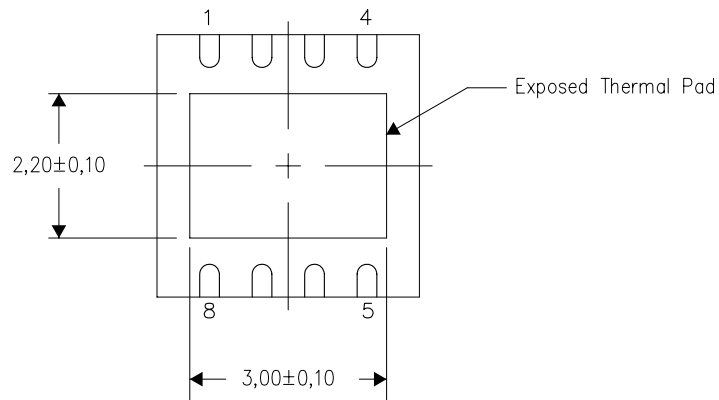

Bottom View

Exposed Thermal Pad Dimensions

4206882/F 01/11

NOTE: All linear dimensions are in millimeters

DRJ (S-PWSON-N8)

SMALL PACKAGE OUTLINE NO-LEAD

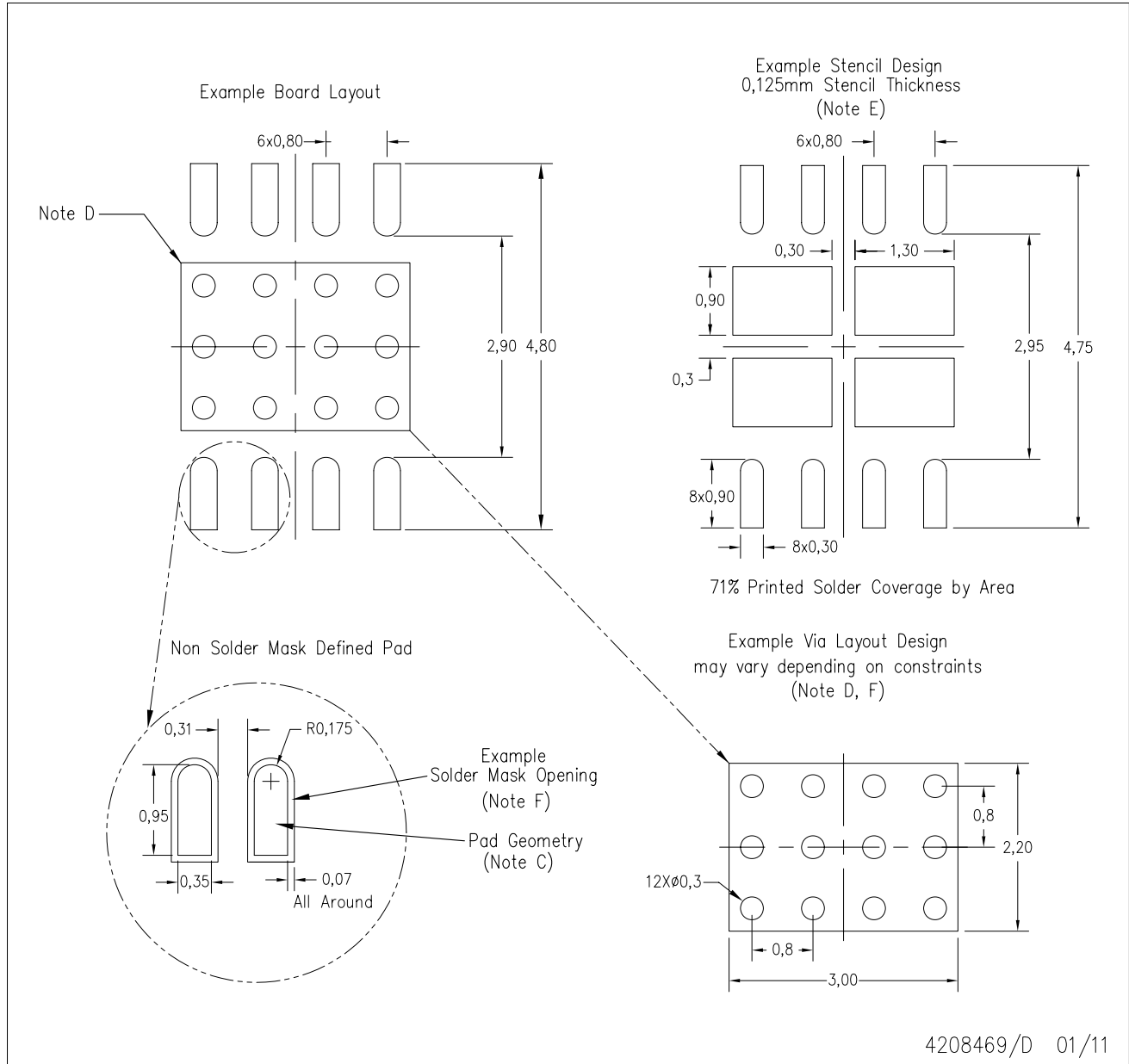

4208469/D 01/11

- NOTES:
- A. All linear dimensions are in millimeters.
 - B. This drawing is subject to change without notice.
 - C. Publication IPC-7351 is recommended for alternate designs.
 - D. This package is designed to be soldered to a thermal pad on the board. Refer to Application Note, Quad Flat-Pack Packages, Texas Instruments Literature No. SLUA271, and also the Product Data Sheets for specific thermal information, via requirements, and recommended board layout. These documents are available at www.ti.com <<http://www.ti.com>>.
 - E. Laser cutting apertures with electropolish and also rounding corners will offer better paste release. Customers should contact their board assembly site for stencil design recommendations. Refer to IPC 7525 for stencil design considerations.
 - F. Customers should contact their board fabrication site for solder mask tolerances and vias tenting recommendations for vias placed in the thermal pad.



D0008A

PACKAGE OUTLINE

SOIC - 1.75 mm max height

SMALL OUTLINE INTEGRATED CIRCUIT



4214825/C 02/2019

NOTES:

- Linear dimensions are in inches [millimeters]. Dimensions in parenthesis are for reference only. Controlling dimensions are in inches. Dimensioning and tolerancing per ASME Y14.5M.
- This drawing is subject to change without notice.
- This dimension does not include mold flash, protrusions, or gate burrs. Mold flash, protrusions, or gate burrs shall not exceed $.006$ [0.15] per side.
- This dimension does not include interlead flash.
- Reference JEDEC registration MS-012, variation AA.

EXAMPLE BOARD LAYOUT

D0008A

SOIC - 1.75 mm max height

SMALL OUTLINE INTEGRATED CIRCUIT



LAND PATTERN EXAMPLE
 EXPOSED METAL SHOWN
 SCALE:8X



SOLDER MASK DETAILS

4214825/C 02/2019

NOTES: (continued)

- 6. Publication IPC-7351 may have alternate designs.
- 7. Solder mask tolerances between and around signal pads can vary based on board fabrication site.

EXAMPLE STENCIL DESIGN

D0008A

SOIC - 1.75 mm max height

SMALL OUTLINE INTEGRATED CIRCUIT



SOLDER PASTE EXAMPLE
BASED ON .005 INCH [0.125 MM] THICK STENCIL
SCALE:8X

4214825/C 02/2019

NOTES: (continued)

8. Laser cutting apertures with trapezoidal walls and rounded corners may offer better paste release. IPC-7525 may have alternate design recommendations.
9. Board assembly site may have different recommendations for stencil design.

P (R-PDIP-T8)

PLASTIC DUAL-IN-LINE PACKAGE

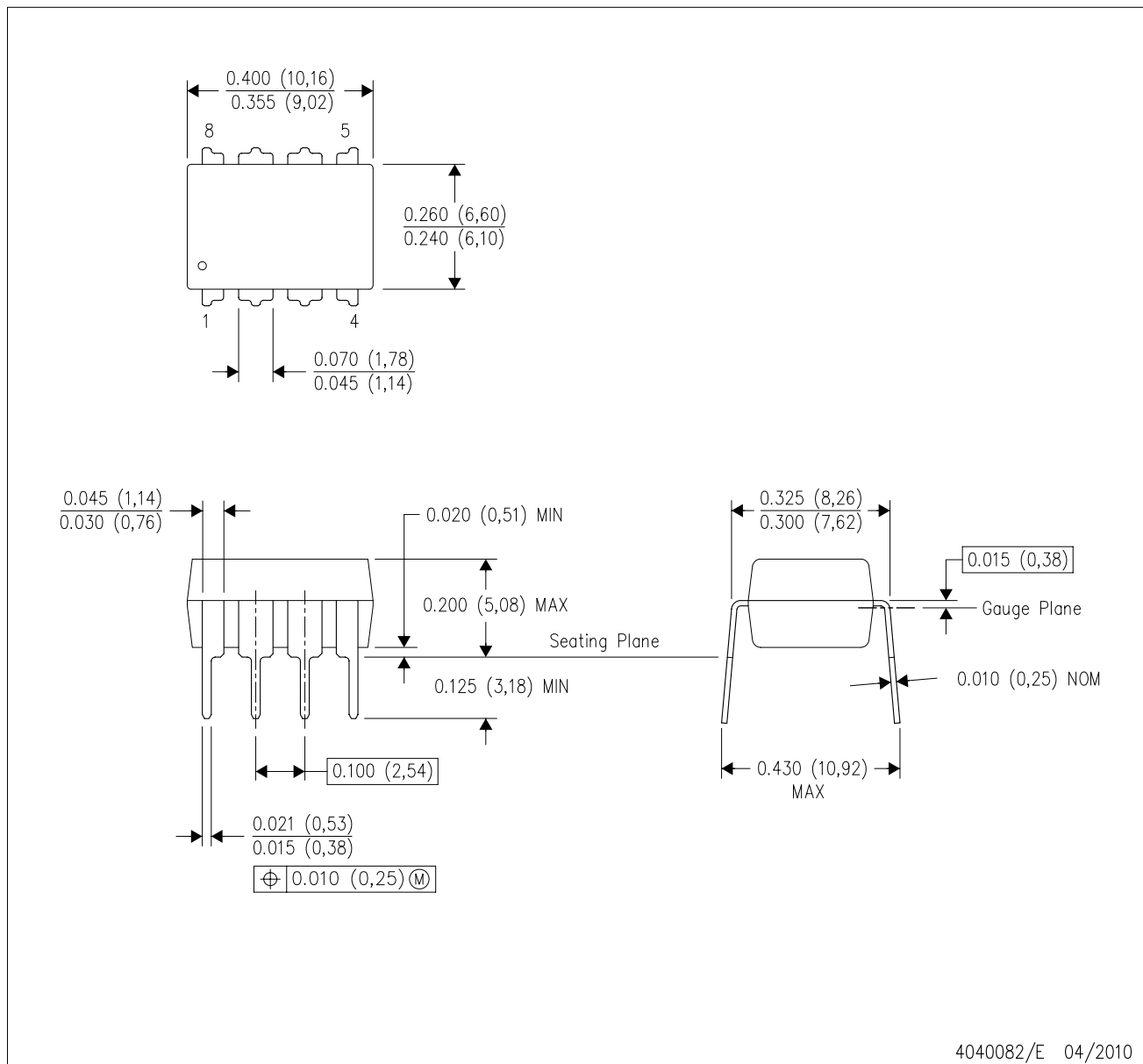

- NOTES:
- A. All linear dimensions are in inches (millimeters).
 - B. This drawing is subject to change without notice.
 - C. Falls within JEDEC MS-001 variation BA.

IMPORTANT NOTICE AND DISCLAIMER

TI PROVIDES TECHNICAL AND RELIABILITY DATA (INCLUDING DATASHEETS), DESIGN RESOURCES (INCLUDING REFERENCE DESIGNS), APPLICATION OR OTHER DESIGN ADVICE, WEB TOOLS, SAFETY INFORMATION, AND OTHER RESOURCES "AS IS" AND WITH ALL FAULTS, AND DISCLAIMS ALL WARRANTIES, EXPRESS AND IMPLIED, INCLUDING WITHOUT LIMITATION ANY IMPLIED WARRANTIES OF MERCHANTABILITY, FITNESS FOR A PARTICULAR PURPOSE OR NON-INFRINGEMENT OF THIRD PARTY INTELLECTUAL PROPERTY RIGHTS.

These resources are intended for skilled developers designing with TI products. You are solely responsible for (1) selecting the appropriate TI products for your application, (2) designing, validating and testing your application, and (3) ensuring your application meets applicable standards, and any other safety, security, or other requirements. These resources are subject to change without notice. TI grants you permission to use these resources only for development of an application that uses the TI products described in the resource. Other reproduction and display of these resources is prohibited. No license is granted to any other TI intellectual property right or to any third party intellectual property right. TI disclaims responsibility for, and you will fully indemnify TI and its representatives against, any claims, damages, costs, losses, and liabilities arising out of your use of these resources.

TI's products are provided subject to TI's Terms of Sale (www.ti.com/legal/termsofsale.html) or other applicable terms available either on ti.com or provided in conjunction with such TI products. TI's provision of these resources does not expand or otherwise alter TI's applicable warranties or warranty disclaimers for TI products.

Mailing Address: Texas Instruments, Post Office Box 655303, Dallas, Texas 75265
Copyright © 2019, Texas Instruments Incorporated

Looking for pricing, stock, or lifecycle information?

Click below to explore more details on WIN SOURCE:

 [View MC34063ADRG4](#) on WIN SOURCE

 [Texas Instruments](#) Information

Optimize Your Supply Chain with WIN SOURCE Solutions

-  Global Sourcing Solution
-  Obsolete Management
-  Cost Control Management
-  Shortage Management
-  Alternative Solution
-  Excess Inventory Management