



**THE DATASHEET OF
SSFD6035**



Main Product Characteristics

V_{DS}	-60V
$R_{DS(ON)}$	40mΩ
I_D	-26A

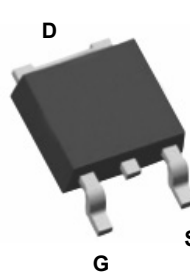

TO-252 (DPAK)

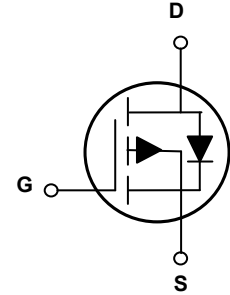

Schematic Diagram

Features and Benefits

- Advanced MOSFET process technology
- Ideal for high efficiency switched mode power supplies
- Low on-resistance with low gate charge
- Fast switching and reverse body recovery



Description

The SSFD6035 utilizes the latest techniques to achieve high cell density and low on-resistance. These features make this device extremely efficient and reliable for use in high efficiency switch mode power supply and a wide variety of other applications.

Absolute Maximum Ratings ($T_A=25^{\circ}C$ unless otherwise specified)

Parameter	Symbol	Max.	Unit
Drain-Source Voltage	V_{DS}	-60	V
Gate-Source Voltage	V_{GS}	±20	V
Drain Current-Continuous (25°C)	I_D	-26	A
Drain Current-Continuous (70°C)		-20	
Drain Current-Pulsed ¹	I_{DM}	-60	A
Maximum Power Dissipation	P_D	60	W
Thermal Resistance, Junction-to-Case	$R_{\theta JC}$	2.5	°C/W
Thermal Resistance, Junction-to-Ambient ²	$R_{\theta JA}$	25	°C/W
Operating Junction Temperature Range	T_J	-55 To +175	°C
Storage Temperature Range	T_{STG}	-55 To +175	°C

Electrical Characteristics ($T_A=25^\circ\text{C}$ unless otherwise noted)

Parameter	Symbol	Conditions	Min.	Typ.	Max.	Unit
On/Off Characteristics						
Drain-Source Breakdown Voltage	BV_{DSS}	$V_{GS}=0V, I_D=-250\mu A$	-60	-	-	V
Drain-Source Leakage Current	I_{DSS}	$V_{DS}=-48V, V_{GS}=0V$	-	-	-1	μA
Gate-Source Leakage Current	I_{GSS}	$V_{GS}=\pm 20V, V_{DS}=0V$	-	-	± 100	nA
Static Drain-Source On-Resistance ³	$R_{DS(ON)}$	$V_{GS}=-10V, I_D=-20A$	-	31	40	m Ω
		$V_{GS}=-4.5V, I_D=-20A$	-	42	55	
Gate Threshold Voltage ³	$V_{GS(th)}$	$V_{GS}=V_{DS}, I_D=-250\mu A$	-1	-1.8	-2.5	V
Forward Transconductance ³	g_{fs}	$V_{DS}=-5V, I_D=-20A$	5	-	-	S
Dynamic and Switching Characteristics						
Total Gate Charge ⁴	Q_g	$V_{DS}=-30V, I_D=-20A,$ $V_{GS}=-10V$	-	48	-	nC
Gate-Source Charge ⁴	Q_{gs}		-	11	-	
Gate-Drain Charge ⁴	Q_{gd}		-	10	-	
Turn-On Delay Time ⁴	$t_{d(on)}$	$V_{DS}=-30V, R_{GEN}=3\Omega,$ $V_{GS}=-10V, I_D=1A$	-	14	-	nS
Rise Time ⁴	t_r		-	20	-	
Turn-Off Delay Time ⁴	$t_{d(off)}$		-	40	-	
Fall Time ⁴	t_f		-	19	-	
Input Capacitance	C_{iss}	$V_{DS}=-30V, V_{GS}=0V,$ $F=1MHz$	-	3060	-	pF
Output Capacitance	C_{oss}		-	300	-	
Reverse Transfer Capacitance	C_{rss}		-	205	-	
Drain-Source Diode Characteristics and Maximum Ratings						
Diode Forward Voltage ³	V_{SD}	$V_{GS}=0V, I_S=-1A$	-	-0.72	-1	V
Reverse Recovery Time	t_{rr}	$I_F=-20A,$ $di/dt=100A/\mu s$	-	26	-	ns
Reverse Recovery Charge	Q_{rr}		-	29	-	nC

Notes:

1. Repetitive Rating: Pulse width limited by maximum junction temperature.
2. Surface Mounted on 1in² FR4 Board, $t \leq 10$ sec.
3. Pulse Test: Pulse width $\leq 300\mu s$, duty cycle $\leq 2\%$.
4. Guaranteed by design, not subject to production testing.

Typical Electrical and Thermal Characteristics

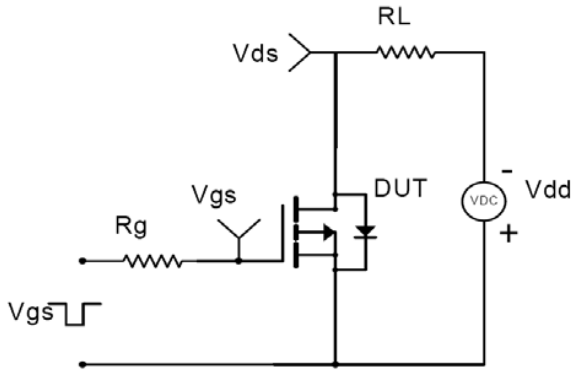

Figure 1. Switching Test Circuit

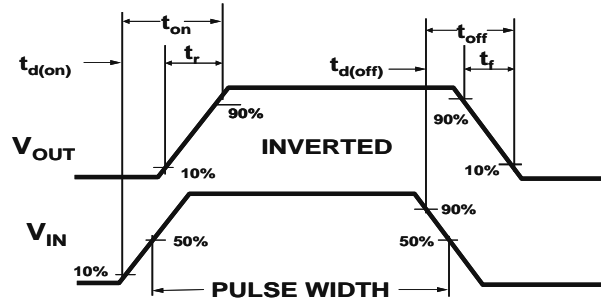

Figure 2. Switching Waveforms

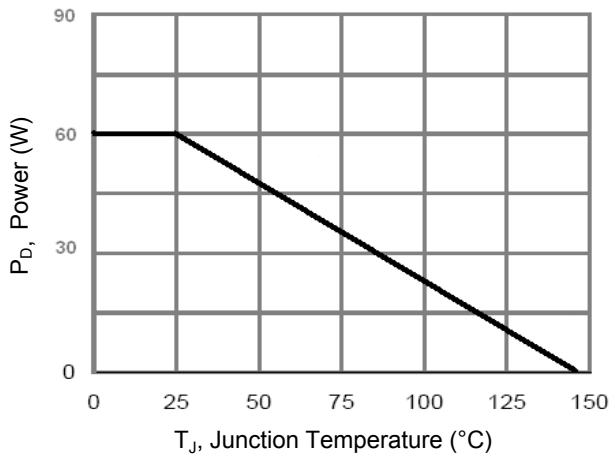

Figure 3. Power Dissipation

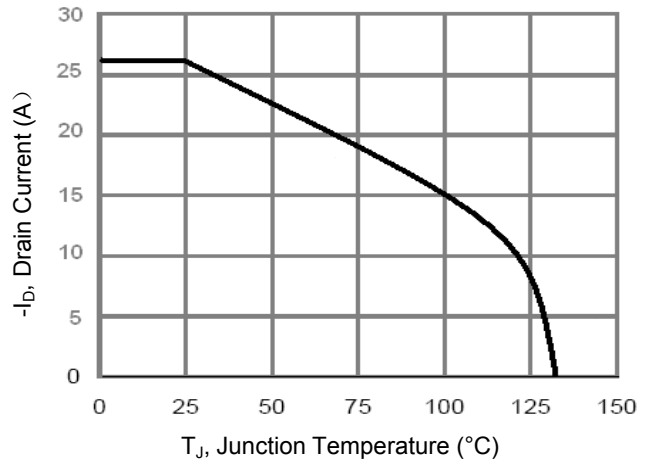

Figure 4. Drain Current

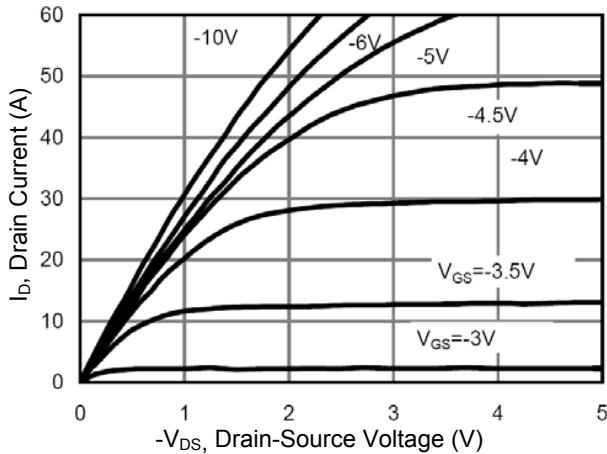

Figure 5. Output Characteristics

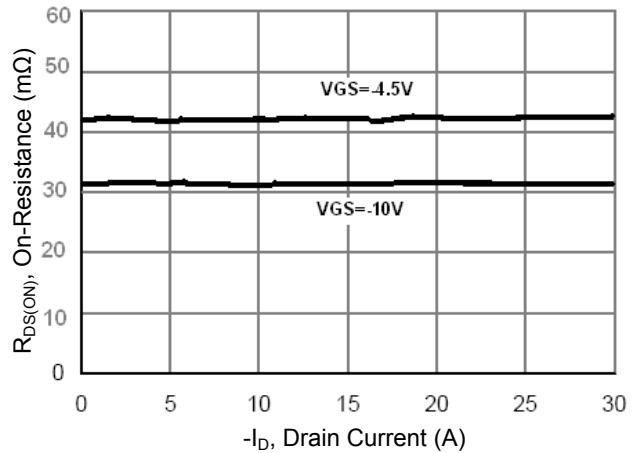

Figure 6. Drain-Source On-Resistance

Typical Electrical and Thermal Characteristics

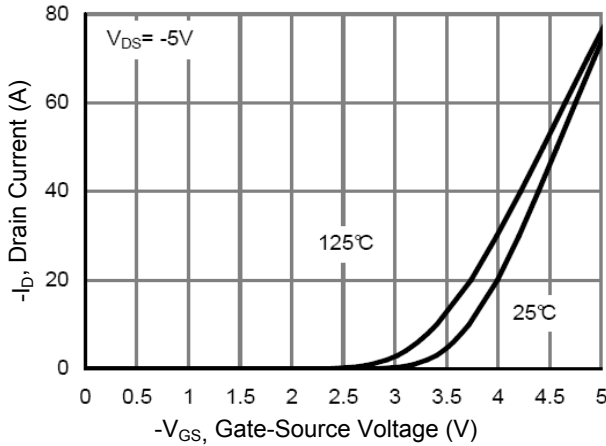

Figure 7. Transfer Characteristics

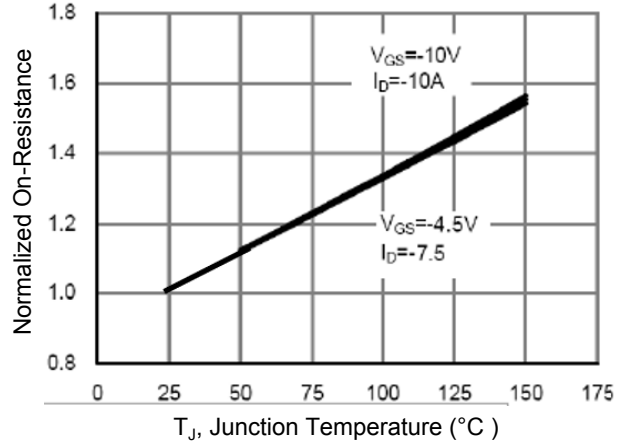

Figure 8. Drain-Source On-Resistance

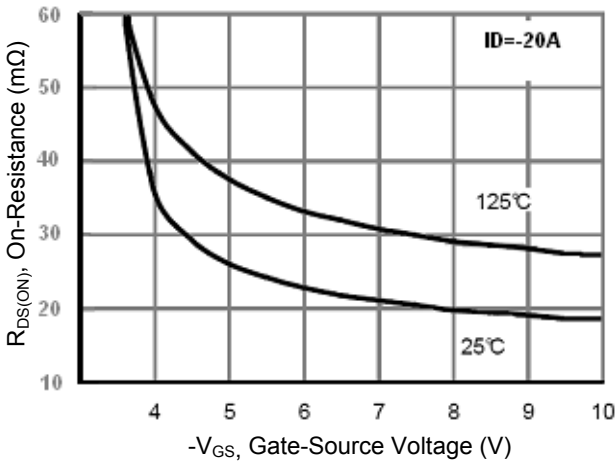

Figure 9. $R_{DS(ON)}$ vs V_{GS}

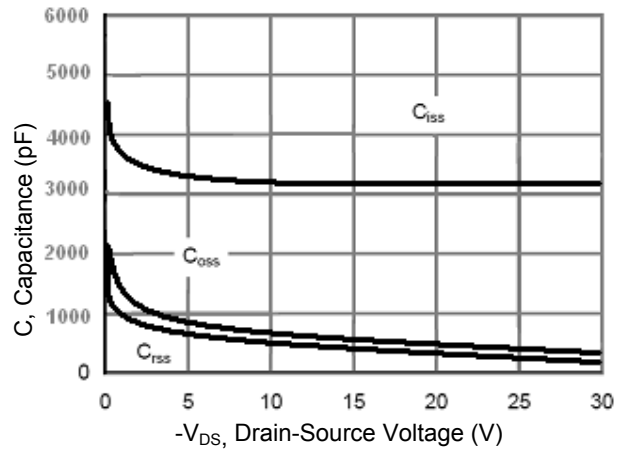

Figure 10. Capacitance vs V_{DS}

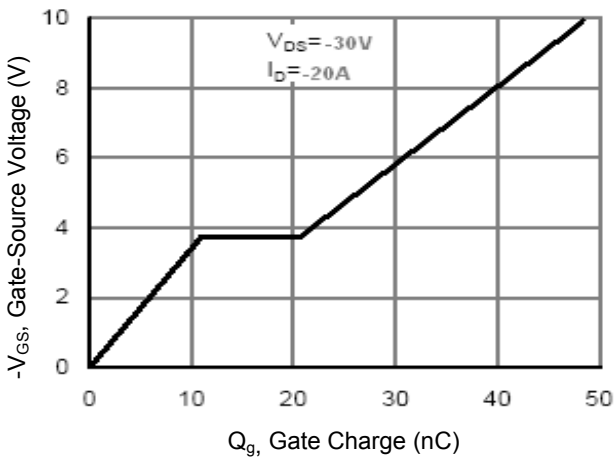

Figure 11. Gate Charge

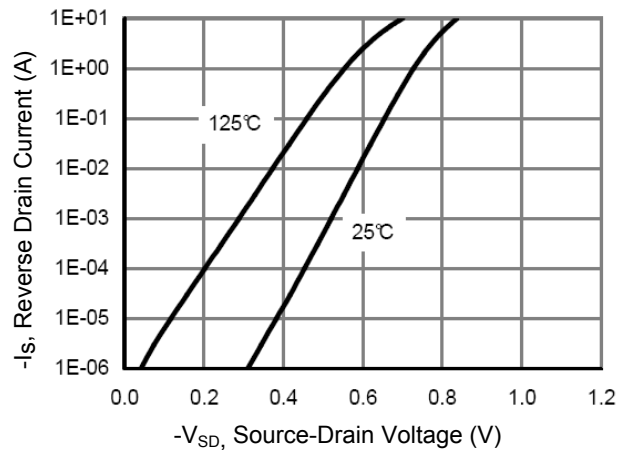

Figure 12. Source - Drain Diode Forward Voltage

Typical Electrical and Thermal Characteristics

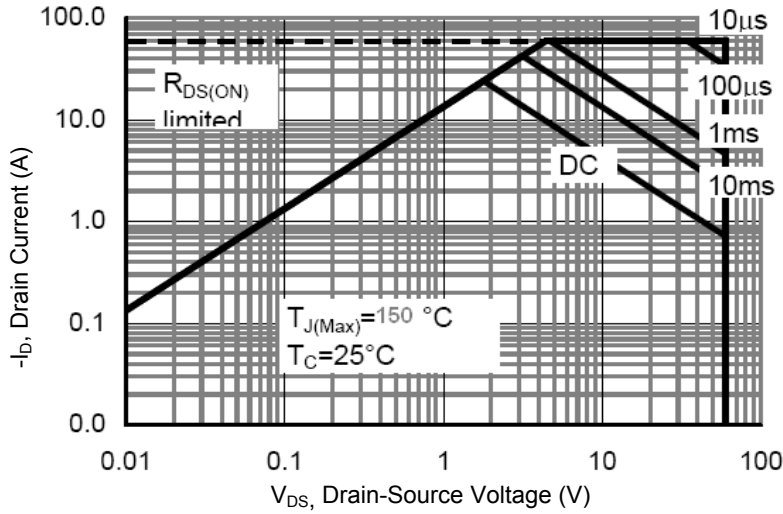

Figure 13. Safe Operation Area

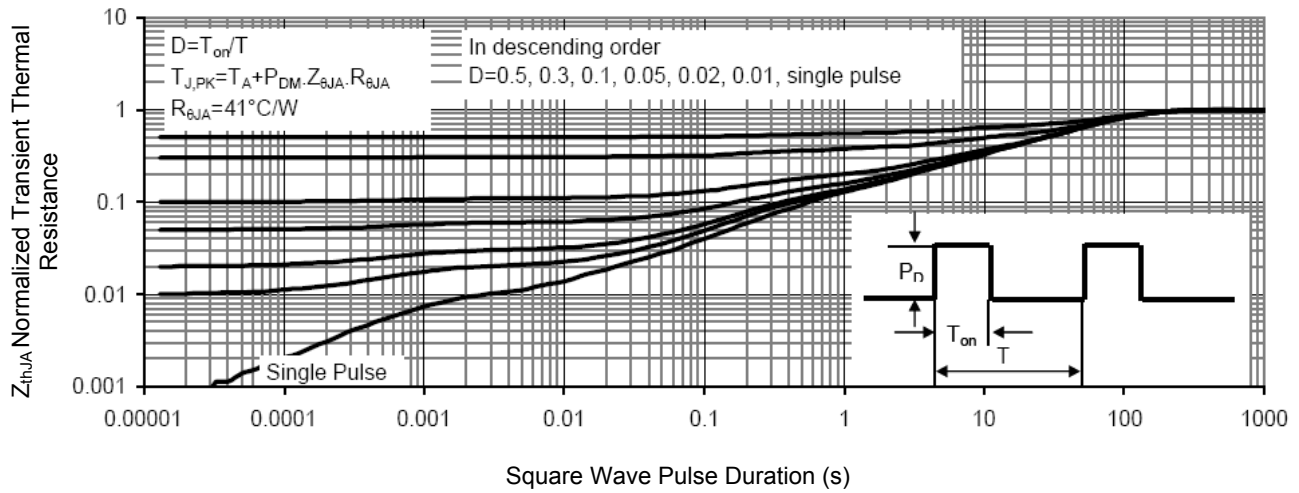
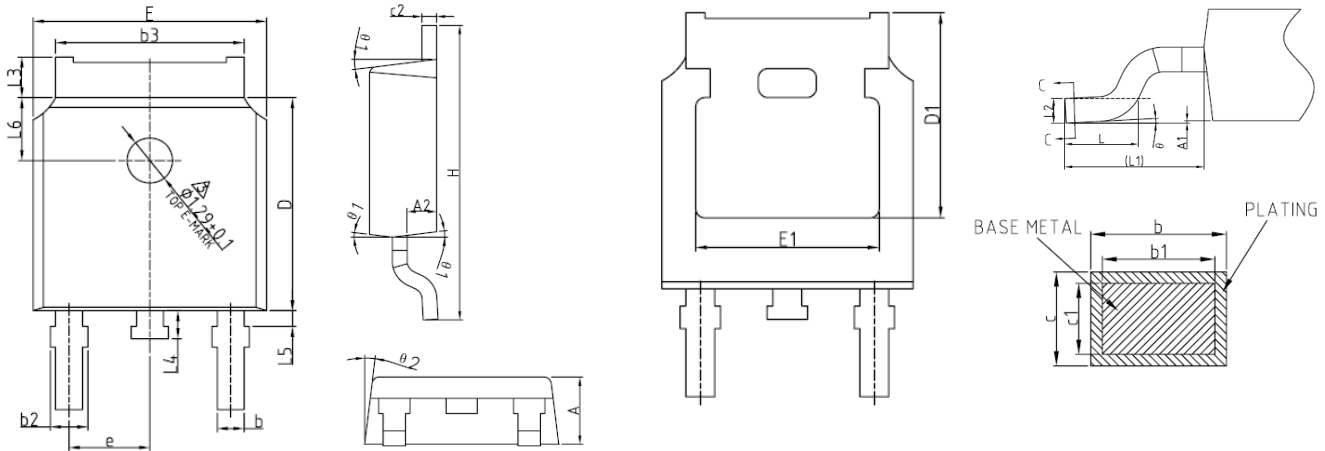

Figure 14. Normalized Maximum Transient Thermal Impedance

Package Outline Dimensions (TO-252/DPAK)



Symbol	Dimensions in Millimeters (Unit:mm)			Symbol	Dimensions in Millimeters (Unit:mm)		
	Min	Nom	Max		Min	Nom	Max
A	2.20	2.30	2.38	E1	4.70	-	-
A1	0.00	-	0.10	e	2.186	2.286	2.386
A2	0.90	1.01	1.10	H	9.80	10.10	10.40
b	0.72	-	0.85	L	1.40	1.50	1.70
b1	0.71	0.76	0.81	L1	2.90 REF		
b2	0.72	-	0.90	L2	0.51 BSC		
b3	5.13	5.33	5.46	L3	0.90	-	1.25
c	0.47	-	0.60	L4	0.60	0.80	1.00
c1	0.46	0.51	0.56	L5	0.15	-	0.75
c2	0.47	-	0.60	L6	1.80 REF		
D	6.00	6.10	6.20	theta	0°	-	8°
D1	5.25	-	-	theta1	5°	7°	9°
E	6.50	6.60	6.70	theta2	5°	7°	9°

Notes:

1. Dimensions are inclusive of plating
2. Package body sizes exclude mold flash and gate burrs. Mold flash at the non-lead sides should be less than 6 mils.
3. Dimension L is measured in gauge plane.
4. Controlling dimension is millimeter, converted inch dimensions are not necessarily exact.

Looking for pricing, stock, or lifecycle information?

Click below to explore more details on WIN SOURCE:

- ⊖ [View SSFD6035 on WIN SOURCE](#)
- ⊖ [GOOD-ARK Electronics Information](#)

Optimize Your Supply Chain with WIN SOURCE Solutions

- ✓ Global Sourcing Solution
- ✓ Obsolete Management
- ✓ Cost Control Management
- ✓ Shortage Management
- ✓ Alternative Solution
- ✓ Excess Inventory Management