



THE DATASHEET OF SAI01



SAI Series Surface-Mount, Separate Excitation Step-down Switching Mode Regulator ICs

Features

- Surface-mount power package
- Output current: 0.4 to 0.5A
- High efficiency: 75 to 88%
- Requires only 4 discrete components
- Internally-adjusted phase correction and output voltage
- Built-in reference oscillator (60kHz)
- Built-in overcurrent and thermal protection circuits

Applications

- Power supplies for telecommunication equipment
- Onboard local power supplies

Line up

Part Number	SAI01	SAI02	SAI03
V _o (V)	5.0	3.3	12.0
I _o (A)	0.5		0.4

Absolute Maximum Ratings

Parameter	Symbol	Ratings	Unit
DC Input Voltage	V _{IN}	35	V
Power Dissipation	P _D	0.75	W
Junction Temperature	T _J	+125	°C
Storage Temperature	T _{stg}	-40 to +125	°C
Thermal Resistance(junction to case)	θ _{J-C}	20	°C/W

Recommended Operating Conditions

Parameter	Symbol	Ratings			Unit
		SAI01	SAI02	SAI03	
DC Input Voltage Range	V _{IN}	7 to 33	5.3 to 28	15 to 33	V
Output Current Range	I _o	0 to 0.5			A
Operating Junction Temperature Range	T _{JOP}	-30 to +125			°C

Electrical Characteristics

(T_a=25°C)

Parameter	Symbol	Ratings									Unit
		SAI01			SAI02			SAI03			
		min.	typ.	max.	min.	typ.	max.	min.	typ.	max.	
Output Voltage	V _o	4.80	5.00	5.20	3.17	3.30	3.43	11.40	12.00	12.60	V
	Conditions	V _{IN} =20V, I _o =0.3A			V _{IN} =15V, I _o =0.3A			V _{IN} =24V, I _o =0.3A			
Efficiency	η	80			75			88			%
	Conditions	V _{IN} =20V, I _o =0.3A			V _{IN} =15V, I _o =0.3A			V _{IN} =24V, I _o =0.3A			
Oscillation Frequency	f	60			60			60			kHz
	Conditions	V _{IN} =20V, I _o =0.3A			V _{IN} =15V, I _o =0.3A			V _{IN} =24V, I _o =0.3A			
Line Regulation	ΔV _{OLINE}	80			60			100			mV
	Conditions	V _{IN} =10 to 30V, I _o =0.3A			V _{IN} =8 to 28V, I _o =0.3A			V _{IN} =18 to 30V, I _o =0.3A			
Load Regulation	ΔV _{OLOAD}	30			20			70			mV
	Conditions	V _{IN} =20V, I _o =0.1 to 0.4A			V _{IN} =15V, I _o =0.1 to 0.4A			V _{IN} =24V, I _o =0.1 to 0.4A			
Temperature Coefficient of Output Voltage	ΔV _O /ΔT _a	±0.5			±0.5			±1.5			mV/°C
Ripple Rejection	R _{REJ}	45			45			45			dB
	Conditions	f=100 to 120Hz			f=100 to 120Hz			f=100 to 120Hz			
Overcurrent Protection Starting Current	I _{s1}	0.55			0.55			0.45			A
	Conditions	V _{IN} =10V			V _{IN} =8V			V _{IN} =18V			

External Dimensions (PS4)

(unit : mm)

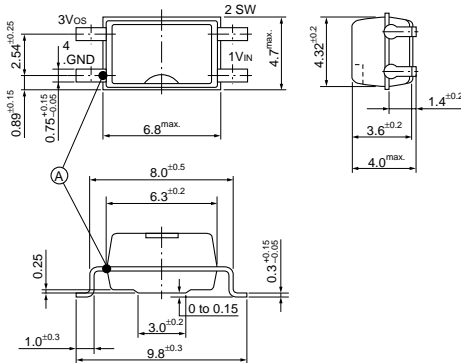

Ⓐ Case Temperature Measuring Point

Pin Assignment

- ① VIN
- ② SWout
- ③ Vos
- ④ GND

Plastic Mold Package Type

Flammability: UL94V-0

Product Mass: Approx. 0.22g

Block Diagram

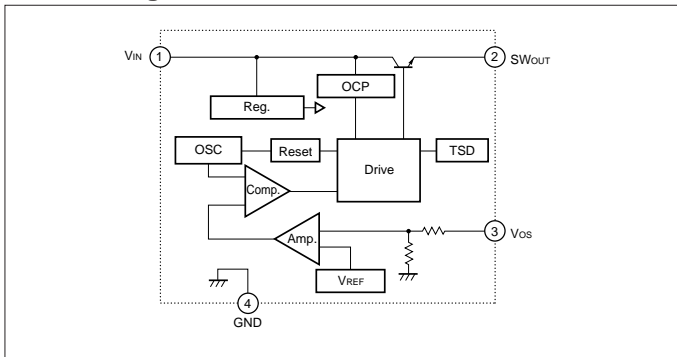

Typical Connection Diagram

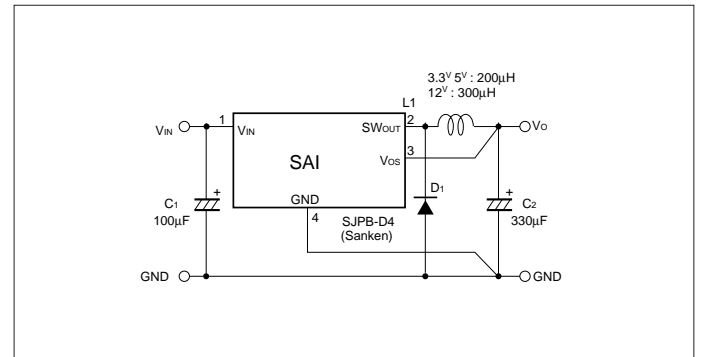

Ta-Pd Characteristics

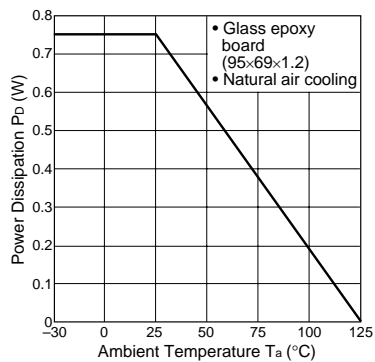

$$P_D = V_O \cdot I_O \left(\frac{100}{\eta \chi} - 1 \right) - V_F \cdot I_O \left(1 - \frac{V_O}{V_{IN}} \right)$$



The efficiency depends on the input voltage and the output current. Therefore, obtain the value from the efficiency graph and substitute the percentage in the formula above.

- Vo : Output voltage
- Io : Output current
- $\eta \chi$: Efficiency (%)
- V_F : Diode D₁ forward voltage
SJPB-D4-0.3V







Thermal design for D₁ must be considered separately.

Looking for pricing, stock, or lifecycle information?

Click below to explore more details on WIN SOURCE:

-  [View SAI01 on WIN SOURCE](#)
-  [Sanken Information](#)

Optimize Your Supply Chain with WIN SOURCE Solutions

-  Global Sourcing Solution
-  Obsolete Management
-  Cost Control Management
-  Shortage Management
-  Alternative Solution
-  Excess Inventory Management