



**THE DATASHEET OF
LM136AH-2.5/883**



LM136A-2.5QML 2.5V Reference Diode

Check for Samples: [LM136A-2.5QML](#), [LM136A-2.5QML-SP](#)

FEATURES

- **Available with Radiation Specification**
 - Total Ionizing Dose 100 krad(Si)
 - ELDRS Free 100 krad(Si)
- **Low Temperature Coefficient**
- **Wide Operating Current of 400 μ A to 10 mA**
- **Specified Temperature Stability**
- **Easily Trimmed for Minimum Temperature Drift**
- **Fast Turn-on**
- **3–Lead Transistor Package**

DESCRIPTION

The LM136A-2.5QML integrated circuit is a precision 2.5V shunt regulator diode. This monolithic IC voltage reference operates as a low-temperature-coefficient 2.5V zener with 0.2 Ω dynamic impedance. A third terminal on the LM136A-2.5QML allows the reference voltage and temperature coefficient to be trimmed easily.

The LM136A-2.5QML is useful as a precision 2.5V low voltage reference for digital voltmeters, power supplies or op amp circuitry. The 2.5V make it convenient to obtain a stable reference from 5V logic supplies. Further, since the LM136A-2.5QML operates as a shunt regulator, it can be used as either a positive or negative voltage reference.

Connection Diagram

Bottom View

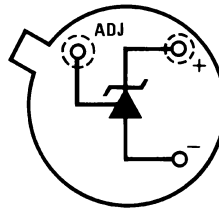

Figure 1. TO Package
See Package Number NDV0003H



Please be aware that an important notice concerning availability, standard warranty, and use in critical applications of Texas Instruments semiconductor products and disclaimers thereto appears at the end of this data sheet.

All trademarks are the property of their respective owners.

Schematic Diagram

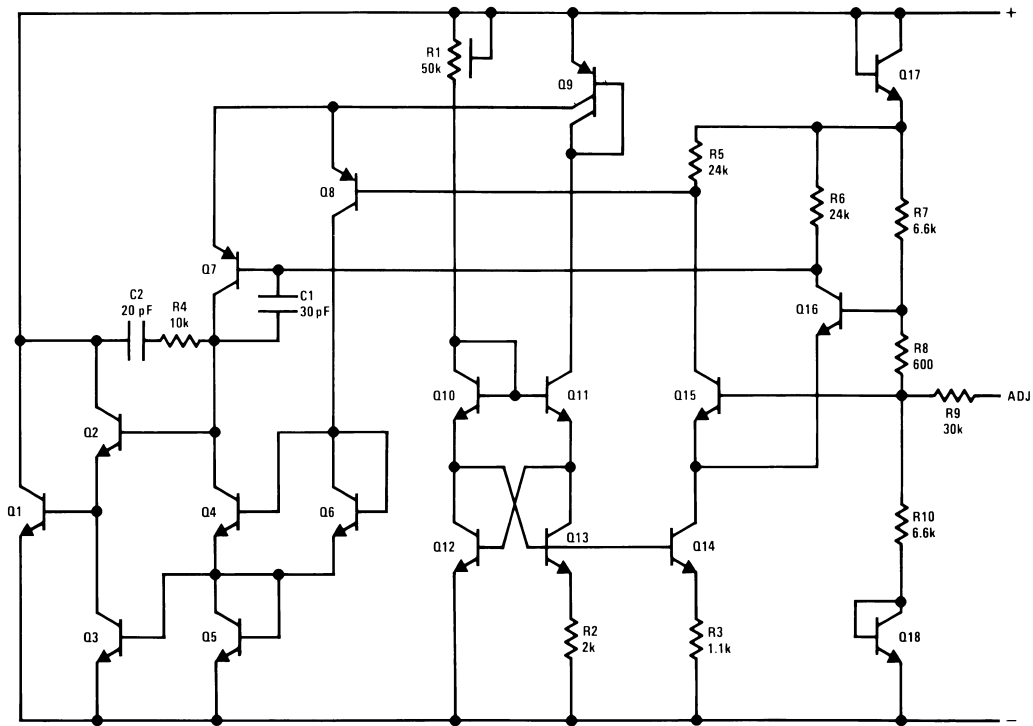

Typical Applications

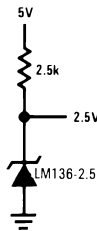
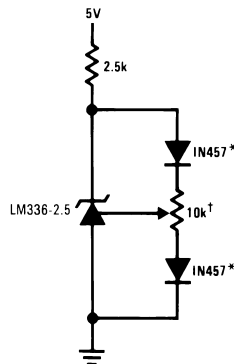

Figure 2. 2.5V Reference



†Adjust to 2.490V
 *Any silicon signal diode

Figure 3. 2.5V Reference with Minimum Temperature Coefficient

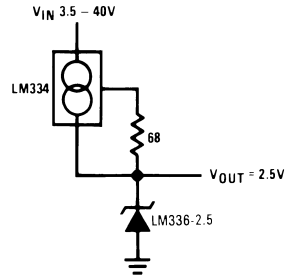

Figure 4. Wide Input Range Reference



These devices have limited built-in ESD protection. The leads should be shorted together or the device placed in conductive foam during storage or handling to prevent electrostatic damage to the MOS gates.

Absolute Maximum Ratings⁽¹⁾

Reverse Current			15 mA
Forward Current			10 mA
Storage Temperature			$-60^{\circ}\text{C} \leq T_A \leq +150^{\circ}\text{C}$
Operating Temperature Range ⁽²⁾			$-55^{\circ}\text{C} \leq T_A \leq +125^{\circ}\text{C}$
Maximum Junction Temperature (T_J) ⁽²⁾			+150°C
Lead Temperature (Soldering 10 seconds)			300°C
Thermal Resistance	θ_{JA}	Still Air Flow	354°C/W
		500LF/Min Air Flow	77°C/W
	θ_{JC}		46°C/W
ESD Rating ⁽³⁾			1,000V

- (1) Absolute Maximum Ratings indicate limits beyond which damage to the device may occur. Operating Ratings indicate conditions for which the device is functional, but do not ensure specific performance limits. For ensured specifications and test conditions, see the Electrical Characteristics. The ensured specifications apply only for the test conditions listed. Some performance characteristics may degrade when the device is not operated under the listed test conditions.
- (2) The maximum power dissipation must be derated at elevated temperatures and is dictated by T_{Jmax} (maximum junction temperature), θ_{JA} (package junction to ambient thermal resistance), and T_A (ambient temperature). The maximum allowable power dissipation at any temperature is $P_{Dmax} = (T_{Jmax} - T_A)/\theta_{JA}$ or the number given in the Absolute Maximum Ratings, whichever is lower.
- (3) Human body model, 1.5K Ω in series with 100pF.

Quality Conformance Inspection

Mil-Std-883, Method 5005 - Group A

Subgroup	Description	Temp°C
1	Static tests at	+25
2	Static tests at	+125
3	Static tests at	-55
4	Dynamic tests at	+25
5	Dynamic tests at	+125
6	Dynamic tests at	-55
7	Functional tests at	+25
8A	Functional tests at	+125
8B	Functional tests at	-55
9	Switching tests at	+25
10	Switching tests at	+125
11	Switching tests at	-55
12	Settling time at	+25
13	Settling time at	+125
14	Settling time at	-55

LM136A-2.5QML Electrical Characteristics DC Parameters⁽¹⁾⁽²⁾

 The following conditions apply, unless otherwise specified. $I_R = 1\text{mA}$

Parameter		Test Conditions	Notes	Min	Max	Unit	Sub-groups
I_{Adj}	Adjust Current	$V_{Adj} = 0.7\text{V}$		-125	+125	μA	1, 2, 3
ΔV_Z	Delta Zener Voltage	$0.4\text{mA} \leq I_Z \leq 10\text{mA}$			6.0	mV	1
					10	mV	2, 3
V_Z	Zener Voltage	$V_{Adj} = \text{Open}$		2.46 5	2.51 5	V	1
				2.44	2.54	V	2, 3
		$V_{Adj} = 0.7\text{V}$		2.39	2.49	V	1
				2.29	2.49	V	2, 3
$V_{Adj} = 1.9\text{V}$		2.49	2.69	V	1, 2, 3		
Z_{RD}	Reverse Dynamic Impedance		See ⁽³⁾		0.6	Ω	1
			See ⁽³⁾		1.0	Ω	2, 3
V_{Stab}	Temperature Stability	$V_Z = \text{Adjusted to } 2.490\text{V}$			18	mV	2, 3

- (1) Pre and post irradiation limits are identical to those listed under DC electrical characteristics. These parts may be dose rate sensitive in a space environment and may demonstrate enhanced low dose rate effect. Radiation end point limits for the noted parameters are specified only for the conditions as specified in Mil-Std-883, Method 1019.
- (2) Low dose rate testing has been performed on a wafer-by-wafer basis, per test method 1019 condition D of MIL-STD-883, with no enhanced low dose rate sensitivity (ELDRS) effect.
- (3) Parameter tested go-no-go only.

LM136A-2.5QML Electrical Characteristics DC Drift Parameters⁽¹⁾⁽²⁾

Delta calculations are performed on QMLV devices at Group B, Subgroup 5 only.

Parameter		Test Conditions	Notes	Min	Max	Unit	Sub-groups
V_Z	Zener Voltage	$V_{Adj} = \text{Open}$		-10	+10	mV	1
		$V_{Adj} = 0.7\text{V}$		-10	+10	mV	1
		$V_{Adj} = 1.9\text{V}$		-10	+10	mV	1

- (1) Pre and post irradiation limits are identical to those listed under DC electrical characteristics. These parts may be dose rate sensitive in a space environment and may demonstrate enhanced low dose rate effect. Radiation end point limits for the noted parameters are specified only for the conditions as specified in Mil-Std-883, Method 1019.
- (2) Low dose rate testing has been performed on a wafer-by-wafer basis, per test method 1019 condition D of MIL-STD-883, with no enhanced low dose rate sensitivity (ELDRS) effect.

Typical Performance Characteristics

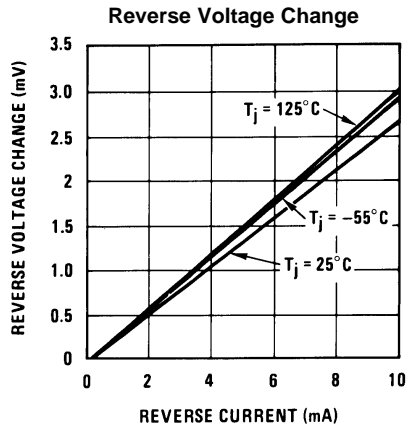

Figure 5.

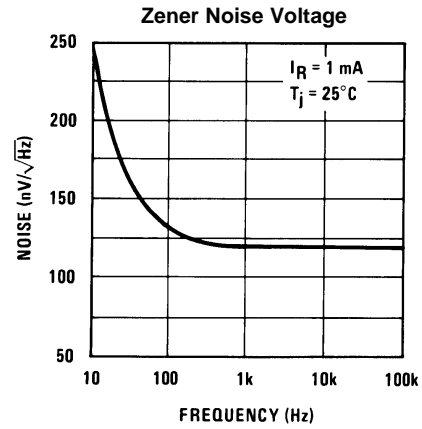

Figure 6.

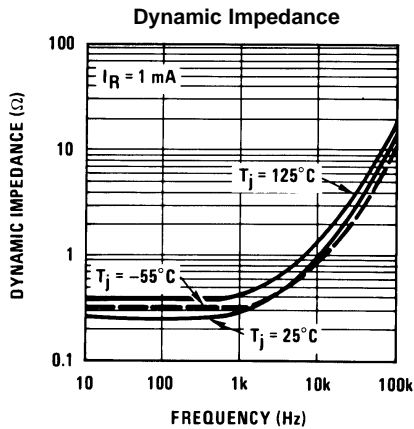

Figure 7.

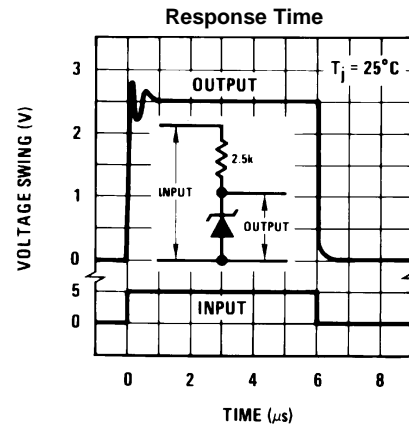

Figure 8.

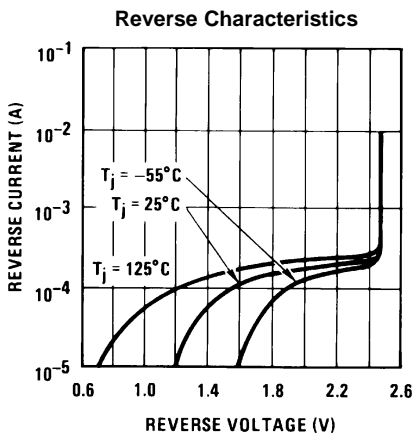

Figure 9.

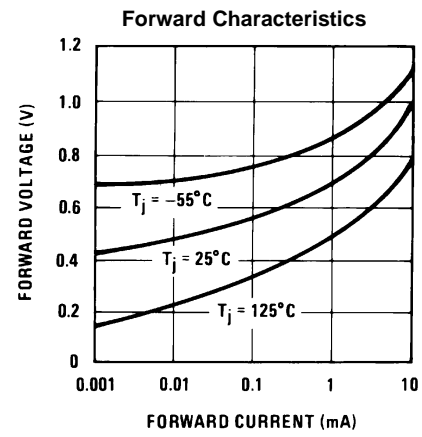

Figure 10.

Typical Performance Characteristics (continued)

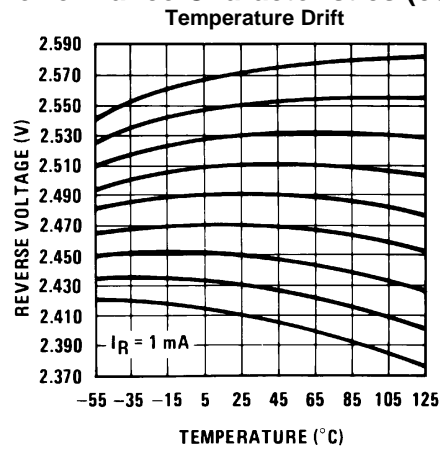

Figure 11.

APPLICATION HINTS

The LM136 voltage reference is much easier to use than ordinary zener diodes. Its low impedance and wide operating current range simplify biasing in almost any circuit. Further, either the breakdown voltage or the temperature coefficient can be adjusted to optimize circuit performance.

[Figure 12](#) shows an LM136 with a 10k potentiometer for adjusting the reverse breakdown voltage. With the addition of R1 the breakdown voltage can be adjusted without affecting the temperature coefficient of the device. The adjustment range is usually sufficient to adjust for both the initial device tolerance and inaccuracies in buffer circuitry.

If minimum temperature coefficient is desired, two diodes can be added in series with the adjustment potentiometer as shown in [Figure 13](#). When the device is adjusted to 2.490V the temperature coefficient is minimized. Almost any silicon signal diode can be used for this purpose such as a 1N914, 1N4148 or a 1N457. For proper temperature compensation the diodes should be in the same thermal environment as the LM136. It is usually sufficient to mount the diodes near the LM136 on the printed circuit board. The absolute resistance of R1 is not critical and any value from 2k to 20k will work.

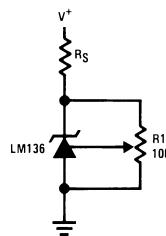

Figure 12. LM136 With Pot for Adjustment of Breakdown Voltage
(Trim Range = ± 120 mV typical)

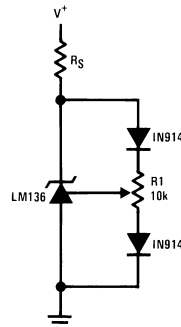
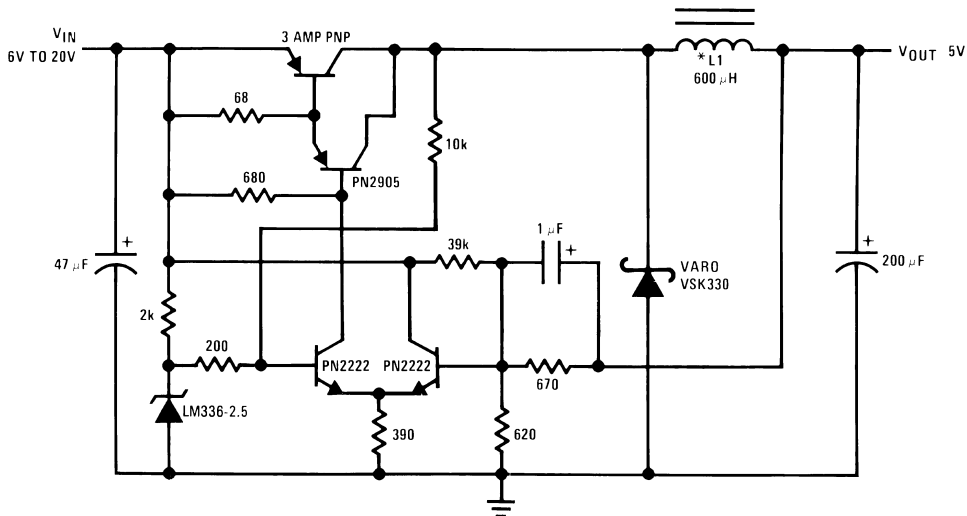

Figure 13. Temperature Coefficient Adjustment
(Trim Range = ± 70 mV typical)



*L1 60 turns #16 wire on Arnold Core A-254168-2

†Efficiency ≈ 80%

Figure 14. Low Cost 2 Amp Switching Regulator†

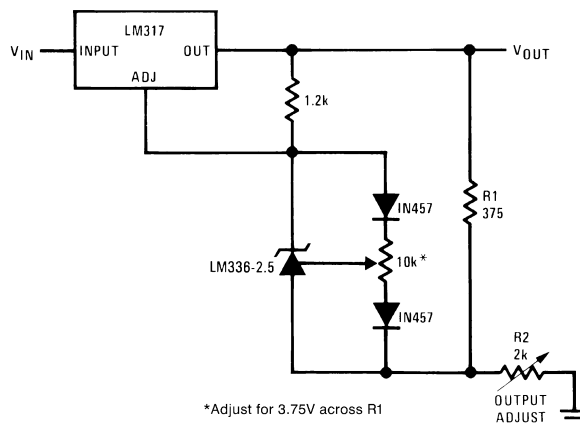

Figure 15. Precision Power Regulator with Low Temperature Coefficient

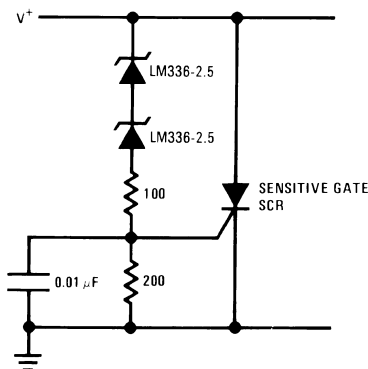
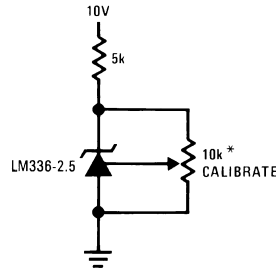

Figure 16. 5V Crowbar



*Does not affect temperature coefficient

Figure 17. Trimmed 2.5V Reference with Temperature Coefficient Independent of Breakdown Voltage

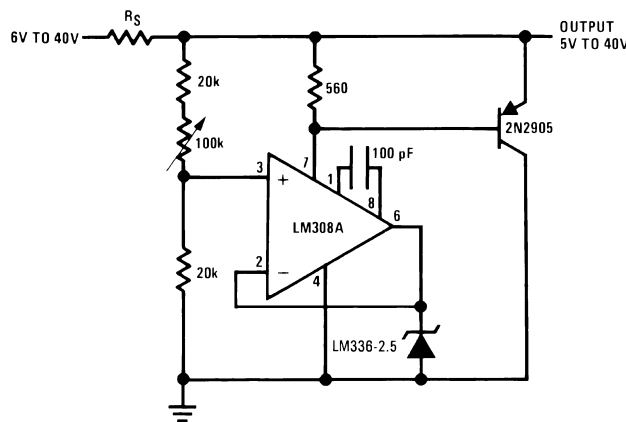

Figure 18. Adjustable Shunt Regulator

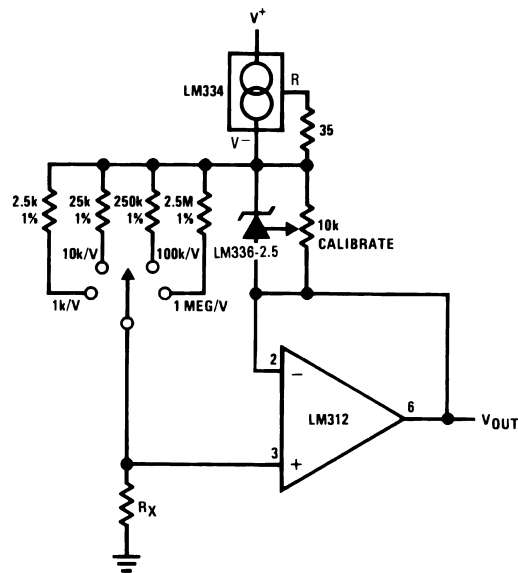

Figure 19. Linear Ohmmeter

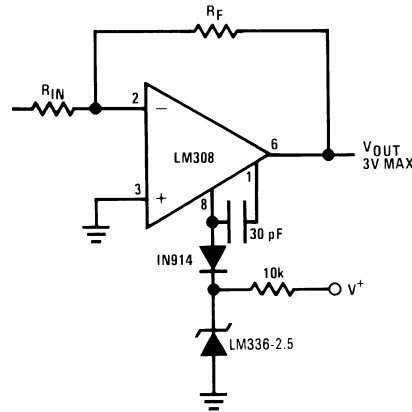

Figure 20. Op Amp with Output Clamped

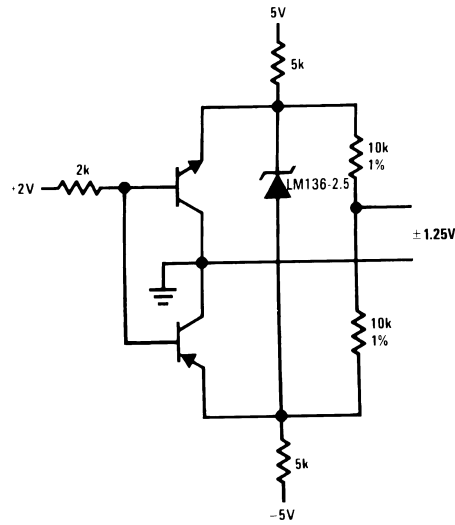

Figure 21. Bipolar Output Reference

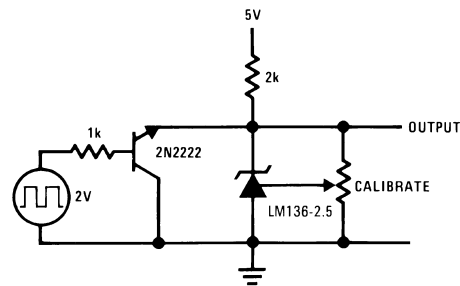

Figure 22. 2.5V Square Wave Calibrator

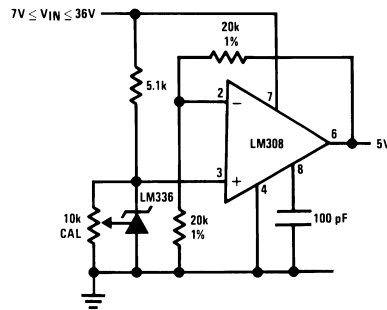

Figure 23. 5V Buffered Reference

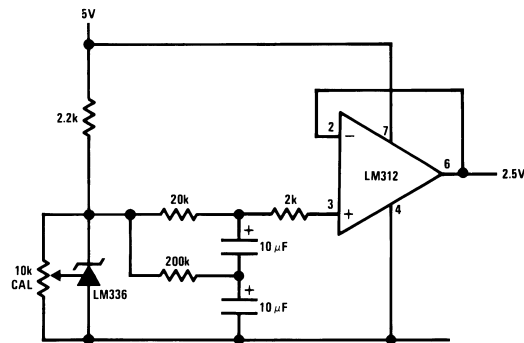

Figure 24. Low Noise Buffered Reference

REVISION HISTORY

Date Released	Revision	Section	Changes
07/06/07	A	New Release, Corporate format	2 MDS datasheets converted into one corporate datasheet format. MNLM136–2.5–X Rev 0A0 and MNLM136A-2.5–X-RH. The ELDRS Part has also been added. Rev. 0E0 will be archived.
10/16/2010	B	Data Sheet Title, General Description, Order Information, Electrical Characteristics, Application Hints	Update with current device information and format. Removed all references to the LM136-2.5 Non "A" package NSID no longer offered. Added Die NSID's to data sheet. Revision A will be Archived.

Changes from Revision D (April 2013) to Revision E
Page

- Changed layout of National Data Sheet to TI format [12](#)

PACKAGING INFORMATION

Orderable Device	Status (1)	Package Type	Package Drawing	Pins	Package Qty	Eco Plan (2)	Lead finish/ Ball material (6)	MSL Peak Temp (3)	Op Temp (°C)	Device Marking (4/5)	Samples
5962R0050101V9A	ACTIVE	DIESALE	Y	0	40	RoHS & Green	Call TI	Level-1-NA-UNLIM	-55 to 125		Samples
5962R0050101VXA	ACTIVE	TO	NDV	3	20	Non-RoHS & Non-Green	Call TI	Call TI	-55 to 125	R0050101VXA Q	Samples
5962R0050102V9A	ACTIVE	DIESALE	Y	0	40	RoHS & Green	Call TI	Level-1-NA-UNLIM	-55 to 125		Samples
5962R0050102VXA	ACTIVE	TO	NDV	3	20	Non-RoHS & Non-Green	Call TI	Call TI	-55 to 125	R0050102VXA Q	Samples
LM136-2.5 MD8	ACTIVE	DIESALE	Y	0	400	RoHS & Green	Call TI	Level-1-NA-UNLIM	-55 to 125		Samples
LM136-2.5 MDE	ACTIVE	DIESALE	Y	0	40	RoHS & Green	Call TI	Level-1-NA-UNLIM	-55 to 125		Samples
LM136-2.5 MDR	ACTIVE	DIESALE	Y	0	40	RoHS & Green	Call TI	Level-1-NA-UNLIM	-55 to 125		Samples
LM136AH-2.5/883	ACTIVE	TO	NDV	3	20	Non-RoHS & Non-Green	Call TI	Call TI	-55 to 125	LM136A-2.5 Q	Samples
LM136AH-2.5RLQV	ACTIVE	TO	NDV	3	20	Non-RoHS & Green	Call TI	Level-1-NA-UNLIM	-55 to 125	R0050102VXA Q	Samples
LM136AH-2.5RQV	ACTIVE	TO	NDV	3	20	Non-RoHS & Green	Call TI	Level-1-NA-UNLIM	-55 to 125	R0050101VXA Q	Samples

(1) The marketing status values are defined as follows:

ACTIVE: Product device recommended for new designs.

LIFEBUY: TI has announced that the device will be discontinued, and a lifetime-buy period is in effect.

NRND: Not recommended for new designs. Device is in production to support existing customers, but TI does not recommend using this part in a new design.

PREVIEW: Device has been announced but is not in production. Samples may or may not be available.

OBSELETE: TI has discontinued the production of the device.

(2) **RoHS:** TI defines "RoHS" to mean semiconductor products that are compliant with the current EU RoHS requirements for all 10 RoHS substances, including the requirement that RoHS substance do not exceed 0.1% by weight in homogeneous materials. Where designed to be soldered at high temperatures, "RoHS" products are suitable for use in specified lead-free processes. TI may reference these types of products as "Pb-Free".

RoHS Exempt: TI defines "RoHS Exempt" to mean products that contain lead but are compliant with EU RoHS pursuant to a specific EU RoHS exemption.

Green: TI defines "Green" to mean the content of Chlorine (Cl) and Bromine (Br) based flame retardants meet JS709B low halogen requirements of <=1000ppm threshold. Antimony trioxide based flame retardants must also meet the <=1000ppm threshold requirement.

(3) MSL, Peak Temp. - The Moisture Sensitivity Level rating according to the JEDEC industry standard classifications, and peak solder temperature.

(4) There may be additional marking, which relates to the logo, the lot trace code information, or the environmental category on the device.

(5) Multiple Device Markings will be inside parentheses. Only one Device Marking contained in parentheses and separated by a "~" will appear on a device. If a line is indented then it is a continuation of the previous line and the two combined represent the entire Device Marking for that device.

(6) Lead finish/Ball material - Orderable Devices may have multiple material finish options. Finish options are separated by a vertical ruled line. Lead finish/Ball material values may wrap to two lines if the finish value exceeds the maximum column width.

Important Information and Disclaimer:The information provided on this page represents TI's knowledge and belief as of the date that it is provided. TI bases its knowledge and belief on information provided by third parties, and makes no representation or warranty as to the accuracy of such information. Efforts are underway to better integrate information from third parties. TI has taken and continues to take reasonable steps to provide representative and accurate information but may not have conducted destructive testing or chemical analysis on incoming materials and chemicals. TI and TI suppliers consider certain information to be proprietary, and thus CAS numbers and other limited information may not be available for release.

In no event shall TI's liability arising out of such information exceed the total purchase price of the TI part(s) at issue in this document sold by TI to Customer on an annual basis.

OTHER QUALIFIED VERSIONS OF LM136A-2.5QML, LM136A-2.5QML-SP :

- Military : [LM136A-2.5QML](#)
- Space : [LM136A-2.5QML-SP](#)

NOTE: Qualified Version Definitions:

- Military - QML certified for Military and Defense Applications
- Space - Radiation tolerant, ceramic packaging and qualified for use in Space-based application

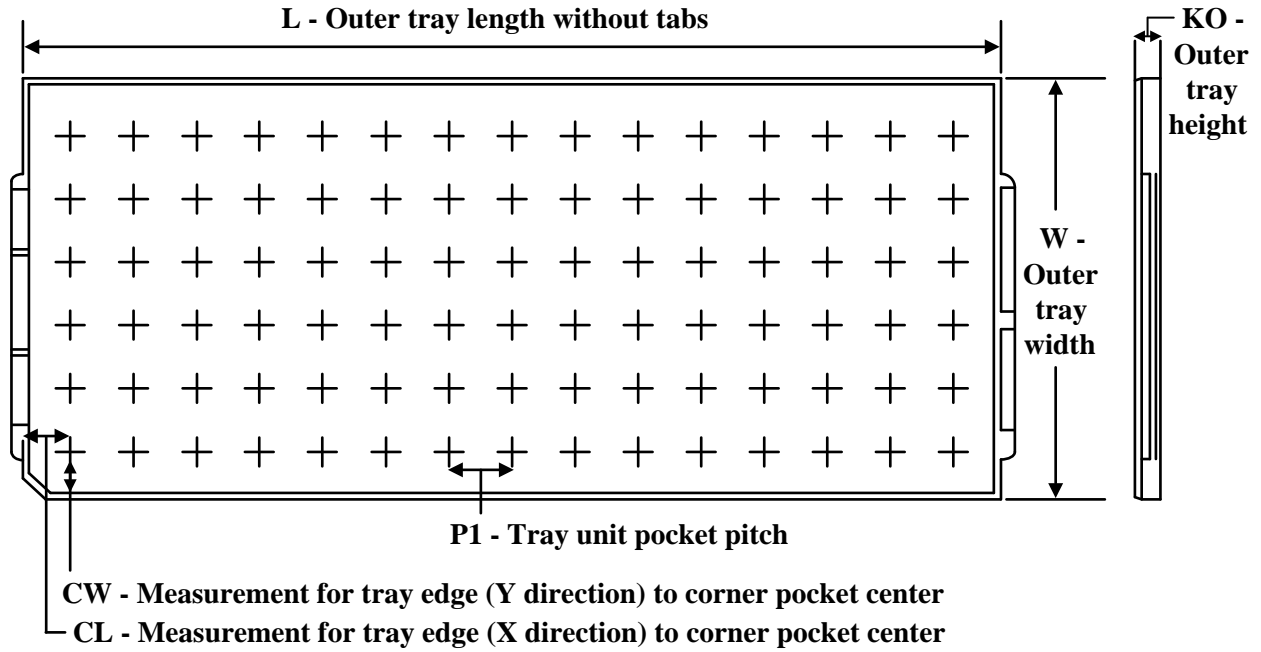
TRAY

Chamfer on Tray corner indicates Pin 1 orientation of packed units.

*All dimensions are nominal

Device	Package Name	Package Type	Pins	SPQ	Unit array matrix	Max temperature (°C)	L (mm)	W (mm)	K0 (µm)	P1 (mm)	CL (mm)	CW (mm)
5962R0050101VXA	NDV	TO-CAN	3	20	2 X 10	150	126.49	61.98	10922	11.43	11.81	19.2
5962R0050102VXA	NDV	TO-CAN	3	20	2 X 10	150	126.49	61.98	10922	11.43	11.81	19.2
LM136AH-2.5/883	NDV	TO-CAN	3	20	2 X 10	150	126.49	61.98	10922	11.43	11.81	19.2
LM136AH-2.5RLQV	NDV	TO-CAN	3	20	2 X 10	150	126.49	61.98	10922	11.43	11.81	19.2
LM136AH-2.5RQV	NDV	TO-CAN	3	20	2 X 10	150	126.49	61.98	10922	11.43	11.81	19.2

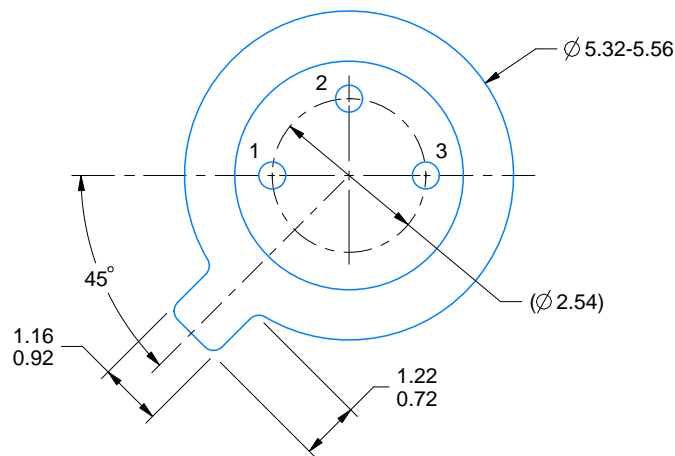
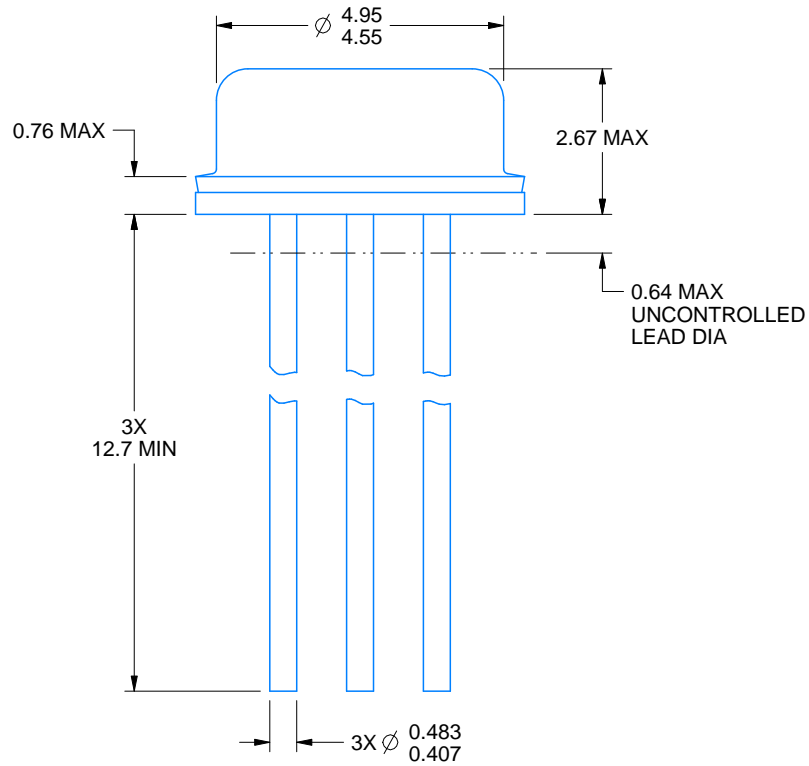

4219876/A 01/2017

NOTES:

1. All linear dimensions are in millimeters. Any dimensions in parenthesis are for reference only. Dimensioning and tolerancing per ASME Y14.5M.
2. This drawing is subject to change without notice.
3. Reference JEDEC registration TO-46.

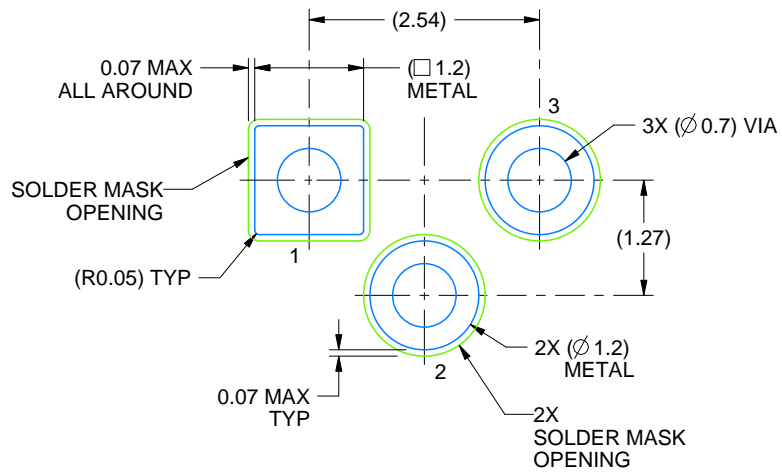

LAND PATTERN EXAMPLE
NON-SOLDER MASK DEFINED
SCALE:12X

IMPORTANT NOTICE AND DISCLAIMER

TI PROVIDES TECHNICAL AND RELIABILITY DATA (INCLUDING DATA SHEETS), DESIGN RESOURCES (INCLUDING REFERENCE DESIGNS), APPLICATION OR OTHER DESIGN ADVICE, WEB TOOLS, SAFETY INFORMATION, AND OTHER RESOURCES "AS IS" AND WITH ALL FAULTS, AND DISCLAIMS ALL WARRANTIES, EXPRESS AND IMPLIED, INCLUDING WITHOUT LIMITATION ANY IMPLIED WARRANTIES OF MERCHANTABILITY, FITNESS FOR A PARTICULAR PURPOSE OR NON-INFRINGEMENT OF THIRD PARTY INTELLECTUAL PROPERTY RIGHTS.

These resources are intended for skilled developers designing with TI products. You are solely responsible for (1) selecting the appropriate TI products for your application, (2) designing, validating and testing your application, and (3) ensuring your application meets applicable standards, and any other safety, security, regulatory or other requirements.

These resources are subject to change without notice. TI grants you permission to use these resources only for development of an application that uses the TI products described in the resource. Other reproduction and display of these resources is prohibited. No license is granted to any other TI intellectual property right or to any third party intellectual property right. TI disclaims responsibility for, and you will fully indemnify TI and its representatives against, any claims, damages, costs, losses, and liabilities arising out of your use of these resources.

TI's products are provided subject to [TI's Terms of Sale](#) or other applicable terms available either on [ti.com](https://www.ti.com) or provided in conjunction with such TI products. TI's provision of these resources does not expand or otherwise alter TI's applicable warranties or warranty disclaimers for TI products.

TI objects to and rejects any additional or different terms you may have proposed.

Mailing Address: Texas Instruments, Post Office Box 655303, Dallas, Texas 75265
Copyright © 2023, Texas Instruments Incorporated

Looking for pricing, stock, or lifecycle information?

Click below to explore more details on WIN SOURCE:

 [View LM136AH-2.5/883](#) on WIN SOURCE

 [Texas Instruments](#) Information

Optimize Your Supply Chain with WIN SOURCE Solutions

-  Global Sourcing Solution
-  Obsolete Management
-  Cost Control Management
-  Shortage Management
-  Alternative Solution
-  Excess Inventory Management