



THE DATASHEET OF INA159AMDGKTEP



PRECISION, GAIN OF 0.2 LEVEL TRANSLATION DIFFERENCE AMPLIFIER

FEATURES

- **Gain of 0.2 to Interface ± 10 -V Signals to Single-Supply ADCs**
- **Gain Accuracy: $\pm 0.024\%$ (max)**
- **Wide Bandwidth: 1.5 MHz**
- **High Slew Rate: 15 V/ μ s**
- **Low Offset Voltage: ± 100 μ V**
- **Low Offset Drift: ± 1.5 μ V/ $^{\circ}$ C**
- **Single-Supply Operation Down to 1.8 V**

APPLICATIONS

- **Industrial Process Controls**
- **Instrumentation**
- **Differential to Single-Ended Conversion**
- **Audio Line Receivers**

SUPPORTS DEFENSE, AEROSPACE, AND MEDICAL APPLICATIONS

- **Controlled Baseline**
- **One Assembly/Test Site**
- **One Fabrication Site**
- **Available in Military (-55° C/ 125° C) Temperature Range⁽¹⁾**
- **Extended Product Life Cycle**
- **Extended Product-Change Notification**
- **Product Traceability**

(1) Additional temperature ranges are available - contact factory

DESCRIPTION

The INA159 is a high slew rate, $G = 1/5$ difference amplifier consisting of a precision op amp with a precision resistor network. The gain of $1/5$ makes the INA159 useful to couple ± 10 -V signals to single-supply analog-to-digital converters (ADCs), particularly those operating on a single +5-V supply. The on-chip resistors are laser-trimmed for accurate gain and high common-mode rejection. Excellent temperature coefficient of resistance (TCR) tracking of the resistors maintains gain accuracy and common-mode rejection over temperature. The input common-mode voltage range extends beyond the positive and negative supply rails. It operates on a total of 1.8-V to 5.5-V single or split supplies. The INA159 reference input uses two resistors for easy mid-supply or reference biasing.

The difference amplifier is the foundation of many commonly-used circuits. The INA159 provides this circuit function without using an expensive external precision resistor network. The INA159 is available in an MSOP-8 surface-mount package and is specified for operation over the extended industrial temperature range, -55° C to 125° C.



Please be aware that an important notice concerning availability, standard warranty, and use in critical applications of Texas Instruments semiconductor products and disclaimers thereto appears at the end of this data sheet.

All trademarks are the property of their respective owners.

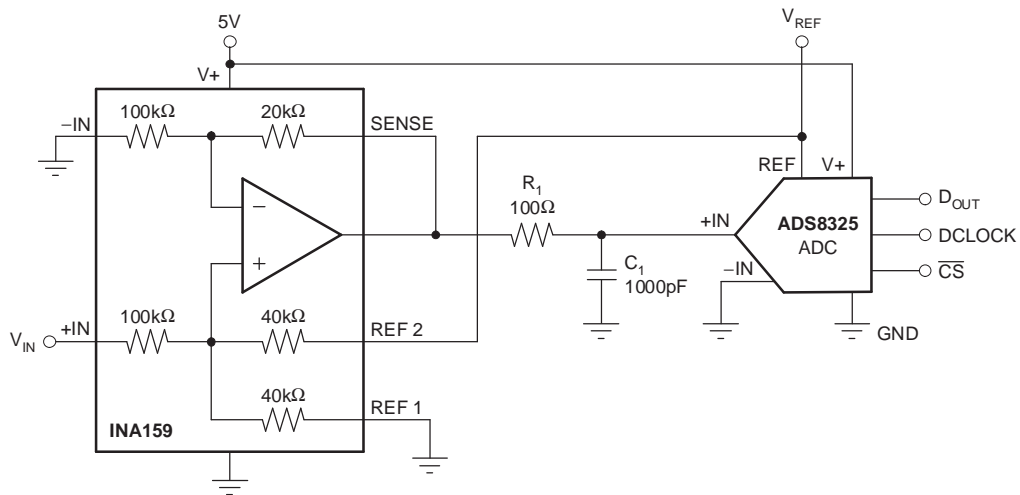

Figure 1. Typical Application



This integrated circuit can be damaged by ESD. Texas Instruments recommends that all integrated circuits be handled with appropriate precautions. Failure to observe proper handling and installation procedures can cause damage.

ESD damage can range from subtle performance degradation to complete device failure. Precision integrated circuits may be more susceptible to damage because very small parametric changes could cause the device not to meet its published specifications.

ORDERING INFORMATION⁽¹⁾

TEMPERATURE	ORDERABLE PART NUMBER ⁽²⁾	PACKAGE LEAD	PACKAGE DESIGNATOR	TOP-SIDE MARKING
-55°C to 125°C	INA159AMDGKTEP	MSOP-8 Tape and reel	DGK	OAA

- (1) For the most current package and ordering information, see the Package Option Addendum at the end of this document, or see the TI web site at www.ti.com.
- (2) Package drawings, standard packing quantities, thermal data, symbolization, and PCB design guidelines are available at www.ti.com/sc/package.

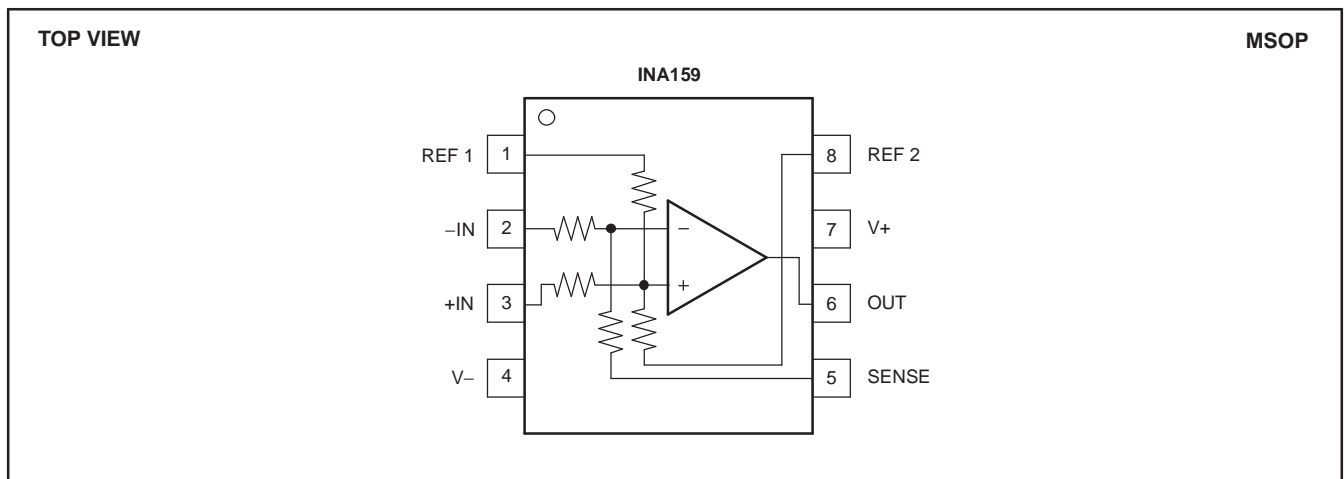

ABSOLUTE MAXIMUM RATINGS⁽¹⁾

over operating free-air temperature range (unless otherwise noted)

		MIN	MAX	UNIT
Supply voltage			+5.5	V
Signal input terminals (–IN and +IN), voltage			±30	V
Reference (REF 1 and REF2) and sense pins	Current		±10	mA
	Voltage	(V–) – 0.5	(V+) + 0.5	V
Output short circuit			Continuous	
Operating temperature		–55	+125	°C
Storage temperature		–65	+150	°C
Junction temperature			+150	°C
ESD rating	Human-Body Model		4000	V
	Charged-Device Model		1000	V

- (1) Stresses above these ratings may cause permanent damage. Exposure to absolute maximum conditions for extended periods may degrade device reliability. These are stress ratings only, and functional operation of the device at these or any other conditions beyond those specified is not supported.

ELECTRICAL CHARACTERISTICS

Boldface limits apply over the specified temperature range, $T_A = -55^\circ\text{C}$ to $+125^\circ\text{C}$.

At $T_A = +25^\circ\text{C}$, $R_L = 10\text{ k}\Omega$ connected to $V_S/2$, REF pin 1 connected to ground, and REF pin 2 connected to $V_{REF} = 5\text{ V}$, unless otherwise noted.

PARAMETER	CONDITIONS	INA159			UNIT
		MIN	TYP	MAX	
OFFSET VOLTAGE ⁽¹⁾	RTO				
Initial ⁽¹⁾	V_{OS} $V_S = \pm 2.5\text{ V}$, Reference and Input Pins Grounded		± 100	± 500	μV
Over Temperature				± 1450	μV
vs Power Supply	PSRR $V_S = \pm 0.9\text{ V}$ to $\pm 2.75\text{ V}$		± 20	± 100	$\mu\text{V/V}$
Over Temperature	PSRR $V_S = \pm 0.9\text{ V}$ to $\pm 2.75\text{ V}$			± 200	$\mu\text{V/V}$
Reference Divider Accuracy ⁽²⁾			± 0.002	± 0.024	%
over Temperature			± 0.002	± 0.050	%
INPUT IMPEDANCE ⁽³⁾					
Differential			240		$\text{k}\Omega$
Common-Mode			60		$\text{k}\Omega$
INPUT VOLTAGE RANGE	RTI				
Common-Mode Voltage Range	V_{CM}				
Positive			17.5		V
Negative			-12.5		V
Common-Mode Rejection Ratio	CMRR $V_{CM} = -10\text{ V}$ to $+10\text{ V}$, $R_S = 0\ \Omega$	80	96		dB
over Temperature		74	94		dB
OUTPUT VOLTAGE NOISE ⁽⁴⁾	RTO				
$f = 0.1\text{ Hz}$ to 10 Hz			10		μV_{PP}
$f = 10\text{ kHz}$			30		$\text{nV}/\sqrt{\text{Hz}}$
GAIN	$V_{REF2} = 4.096\text{ V}$, R_L Connected to GND, $(V_{IN+}) - (V_{IN-}) = -10\text{ V}$ to $+10\text{ V}$, $V_{CM} = 0\text{ V}$				
Initial	G		0.2		V/V
Error			± 0.005	± 0.024	%
vs Temperature				± 0.035	%
Nonlinearity			± 0.0002		% of FS
OUTPUT					
Voltage, Positive	$V_{REF2} = 4.096\text{ V}$, R_L Connected to GND	$(V+) - 0.1$	$(V+) - 0.02$		V
over Temperature		$(V+) - 0.2$			V
Voltage, Negative	$V_{REF2} = 4.096\text{ V}$, R_L Connected to GND	$(V-) + 0.048$	$(V-) + 0.01$		V
over Temperature		$(V-) + 0.070$			V
Current Limit, Continuous to Common			± 60		mA
Capacitive Load			See Typical Characteristic		pF
Open-Loop Output Impedance	R_O $f = 1\text{ MHz}$, $I_O = 0$		110		Ω
FREQUENCY RESPONSE					
Small-Signal Bandwidth		-3 dB	1.5		MHz
Slew Rate	SR		15		$\text{V}/\mu\text{s}$
Settling Time, 0.01%	t_S 4 V Output Step, $C_L = 100\text{ pF}$		1		μs

(1) Includes effects of amplifier input bias and offset currents.
 (2) Reference divider accuracy specifies the match between the reference divider resistors using the configuration in [Figure 2](#).
 (3) Internal resistors are ratio matched but have 20% absolute value.
 (4) Includes effects of amplifier input current noise and thermal noise contribution of resistor network.

ELECTRICAL CHARACTERISTICS (continued)

Boldface limits apply over the specified temperature range, $T_A = -55^{\circ}\text{C}$ to $+125^{\circ}\text{C}$.

At $T_A = +25^{\circ}\text{C}$, $R_L = 10\text{ k}\Omega$ connected to $V_S/2$, REF pin 1 connected to ground, and REF pin 2 connected to $V_{REF} = 5\text{ V}$, unless otherwise noted.

PARAMETER	CONDITIONS	INA159			UNIT
		MIN	TYP	MAX	
Overload Recovery Time	50% Overdrive		250		ns
POWER SUPPLY					
Specified Voltage Range	V_S			+5	V
Operating Voltage Range		+1.8		+5.5	V
Quiescent Current	I_Q	$I_O = 0\text{ mA}$, $V_S = \pm 2.5\text{ V}$, Reference and Input Pins Grounded			mA
over Temperature					2.0
TEMPERATURE RANGE					
Specified Range		-55		+125	$^{\circ}\text{C}$
Operating Range		-55		+125	$^{\circ}\text{C}$
Storage Range		-65		+150	$^{\circ}\text{C}$
Thermal Resistance	θ_{JA}				
MSOP-8	Surface Mount		150		$^{\circ}\text{C}/\text{W}$

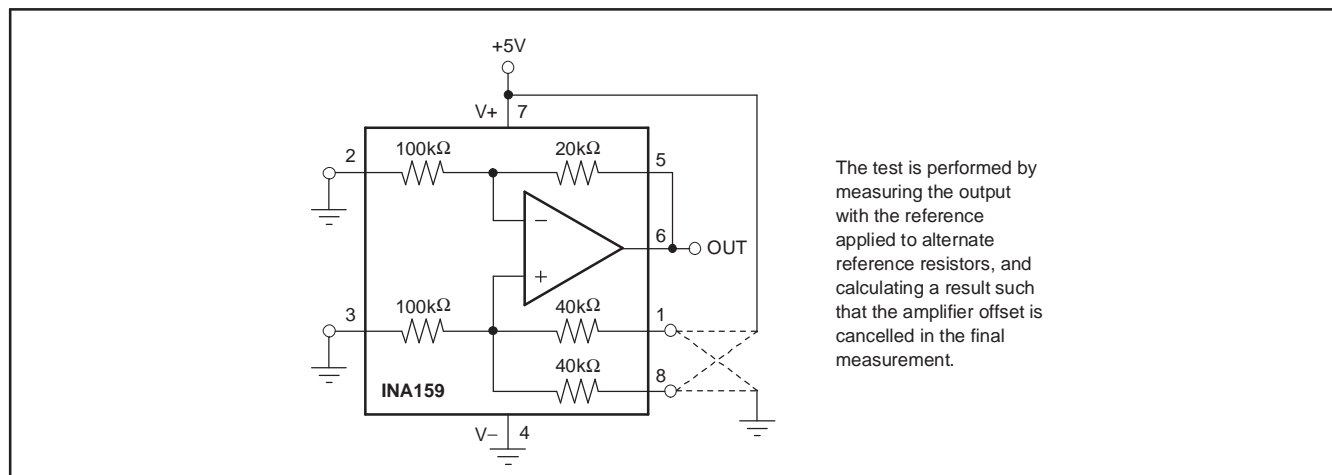
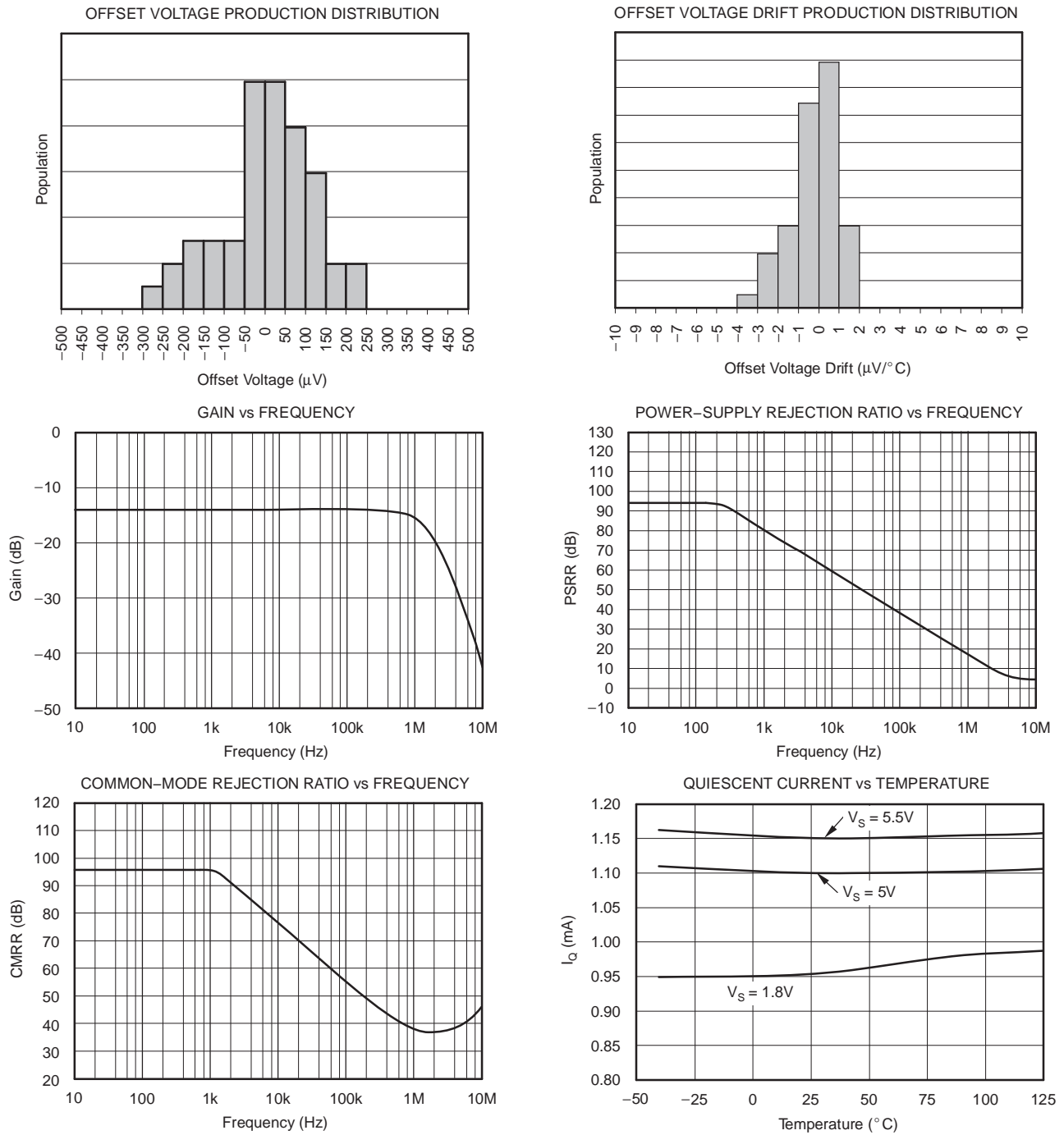

Figure 2. Test Circuit for Reference Divider Accuracy

TYPICAL CHARACTERISTICS

At $T_A = +25^\circ\text{C}$, $R_L = 10\text{ k}\Omega$ connected to $V_S/2$, REF pin 1 connected to ground, and REF pin 2 connected to $V_{REF} = 5\text{ V}$, unless otherwise noted.



TYPICAL CHARACTERISTICS (continued)

At $T_A = +25^\circ\text{C}$, $R_L = 10\text{ k}\Omega$ connected to $V_S/2$, REF pin 1 connected to ground, and REF pin 2 connected to $V_{REF} = 5\text{ V}$, unless otherwise noted.

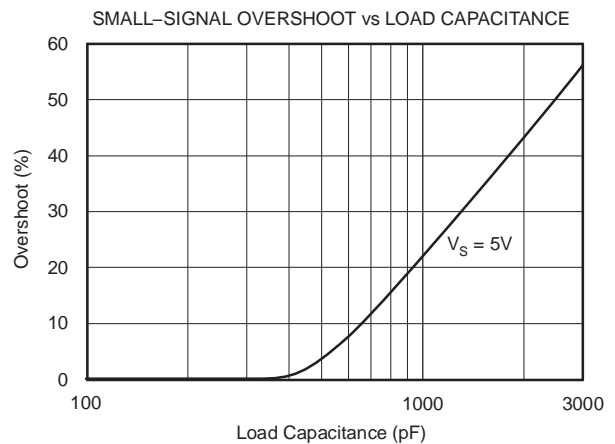
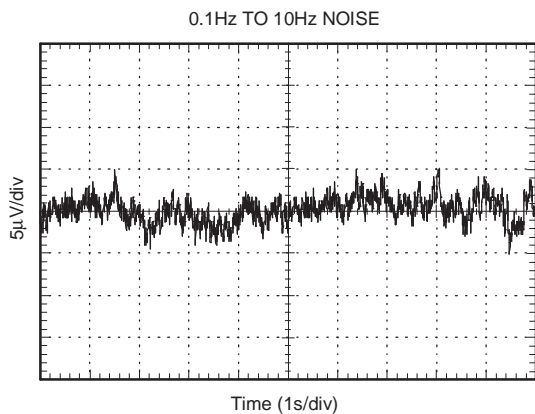
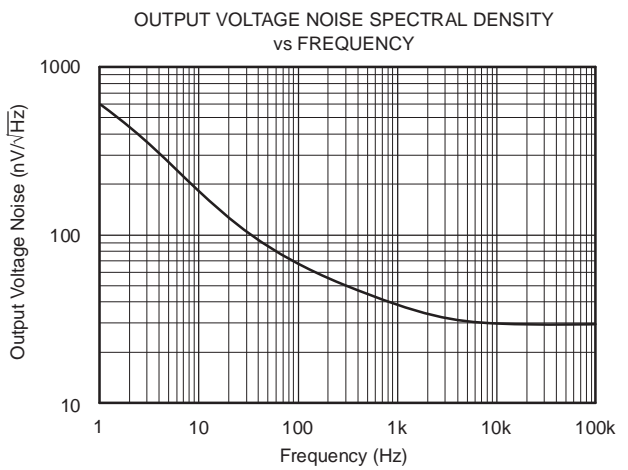
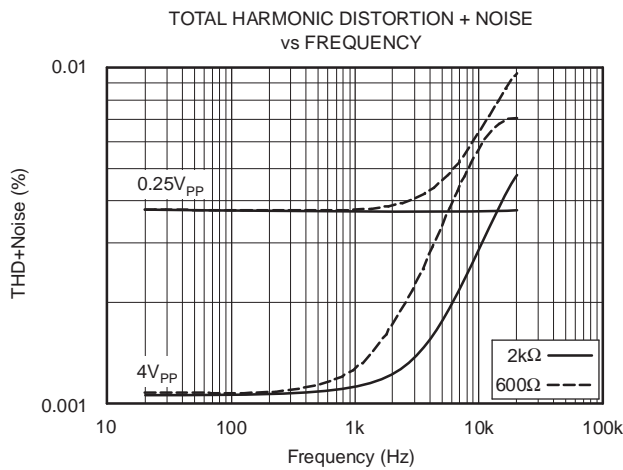
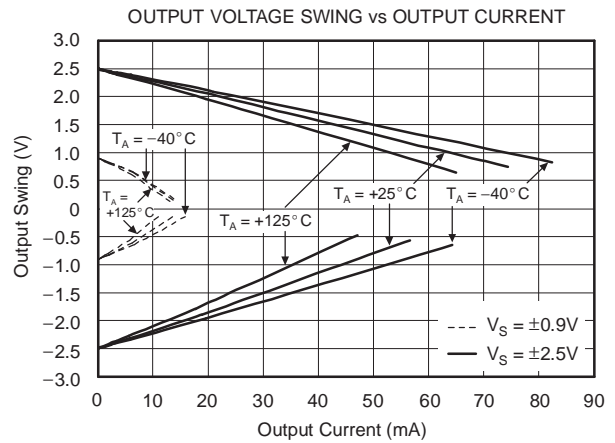
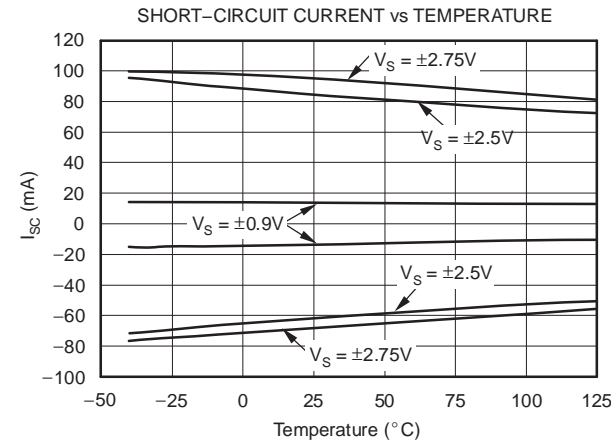

TYPICAL CHARACTERISTICS (continued)

At $T_A = +25^\circ\text{C}$, $R_L = 10\text{ k}\Omega$ connected to $V_S/2$, REF pin 1 connected to ground, and REF pin 2 connected to $V_{REF} = 5\text{ V}$, unless otherwise noted.

SMALL-SIGNAL STEP RESPONSE

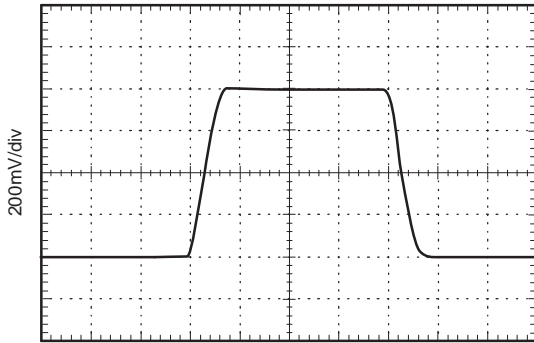

Time (500ns/div)

LARGE-SIGNAL STEP RESPONSE

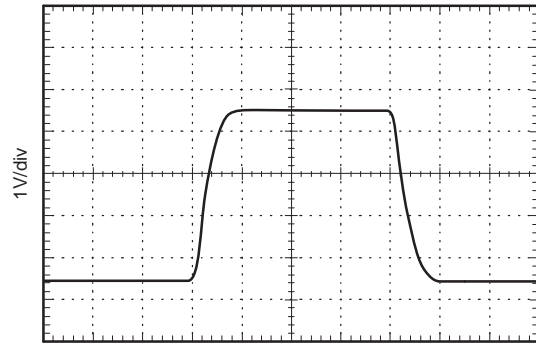

Time (500ns/div)

SETTLING TIME

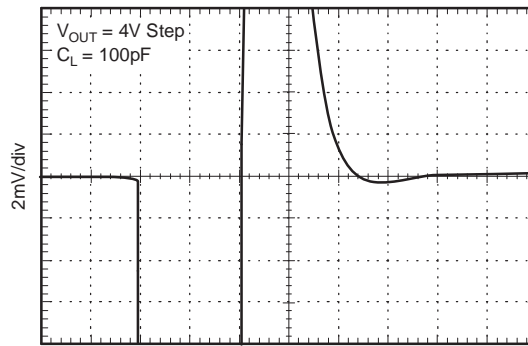

Time (250ns/div)

APPLICATION INFORMATION

The internal op amp of the INA159 has a rail-to-rail common-mode voltage capability at its inputs. A rail-to-rail op amp allows the use of ± 10 -V inputs into a circuit biased to 1/2 of a 5-V reference (2.5-V quiescent output). The inputs to the op amp will swing from approximately 400 mV to 3.75 V in this application.

The unique input topology of the INA159 eliminates the input offset transition region typical of most rail-to-rail complementary stage operational amplifiers. This allows the INA159 to provide superior glitch- and transition-free performance over the entire common-mode range.

Good layout practice includes the use of a 0.1- μ F bypass capacitor placed closely across the supply pins.

COMMON-MODE RANGE

The common-mode range of the INA159 is a function of supply voltage and reference. Where both pins, REF1 and REF2, are connected together:

$$V_{CM+} = (V+) + 5[(V+) - V_{REF}] \quad (1)$$

$$V_{CM-} = (V-) - 5[V_{REF} - (V-)] \quad (2)$$

Where one REF pin is connected to the reference, and the other pin grounded (1/2 reference connection):

$$V_{CM+} = (V+) + 5[(V+) - (0.5V_{REF})] \quad (3)$$

$$V_{CM-} = (V-) - 5[(0.5V_{REF}) - (V-)] \quad (4)$$

Some typical values are shown in [Table 1](#).

Table 1. Common-Mode Range For Various Supply and Reference Voltages

REF 1 and REF 2 Connected Together				
V+	V-	V _{REF}	V _{CM+}	V _{CM-}
5	0	3	15	-15
5	0	2.5	17.5	-12.5
5	0	1.25	23.75	-6.25
1/2 Reference Connection				
V+	V-	V _{REF}	V _{CM+}	V _{CM-}
5	0	5	17.5	-12.5
5	0	4.096	19.76	-10.24
5	0	2.5	23.75	-6.25
3.3	0	3.3	11.55	-8.25
3.3	0	2.5	13.55	-6.25
3.3	0	1.25	16.675	-3.125

Input and Output Relationships for Various Reference and Connection Combinations

V_{REF} (V)	REF CONNECTION	V_{OUT} for $V_{IN} = 0$ (V)	LINEAR V_{IN} RANGE (V)	USEFUL V_{OUT} SWING (V)
5		2.5	+10 0 -10	4.5 (±2V swing) 0.5
4.096		2.048	10 0 -10	4.048 (±2V swing) 0.048
3.3		1.65	+10 0 -7.885	3.65 (-1.577V, +2V swing) 0.048
2.5		1.25	+10 (also +5) 0 -6 (also -5)	3.25 (-1.2V, +2V swing) 0.048
1.8		0.9	+10 0 -4.26	2.9 (-0.852V, +2V swing) 0.048
2.5		2.5	+10 0 -10	4.5 (= 2V swing) 0.5
1.8		1.8	+10 0 -8.76	3.8 (-1.752V, +2V swing) 0.048
1.2		1.2	+10 0 -5.76	3.2 (-1.15V, +2V swing) 0.048

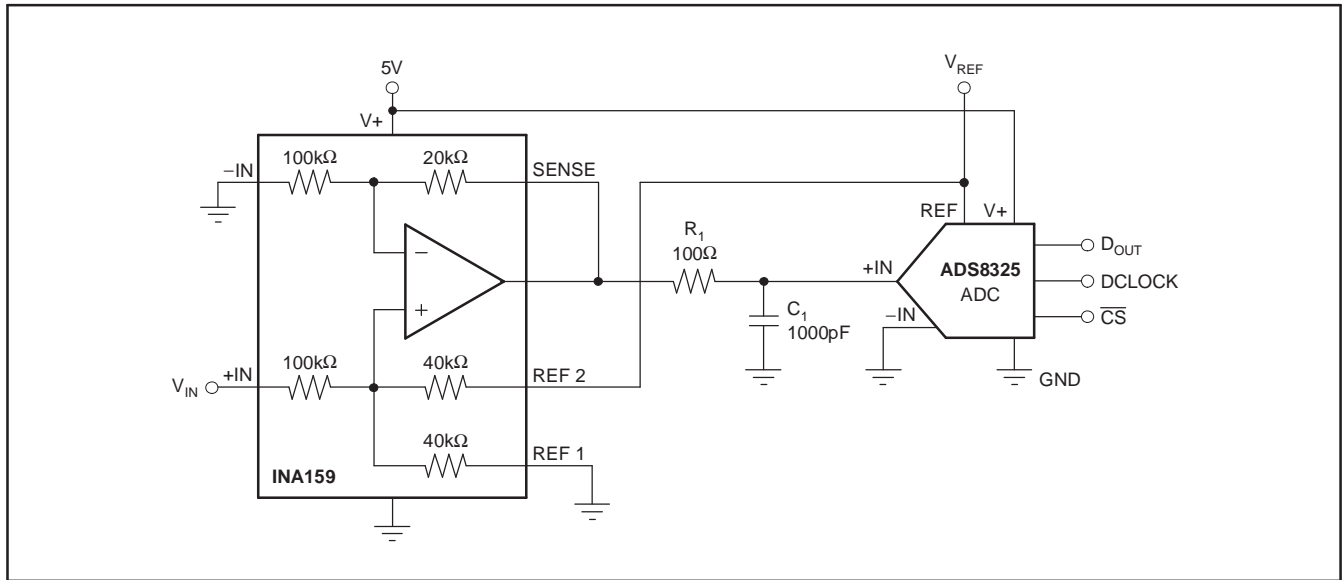

Figure 3. Typical Application Circuit Interfacing to Medium-Speed, Single-Supply ADCs

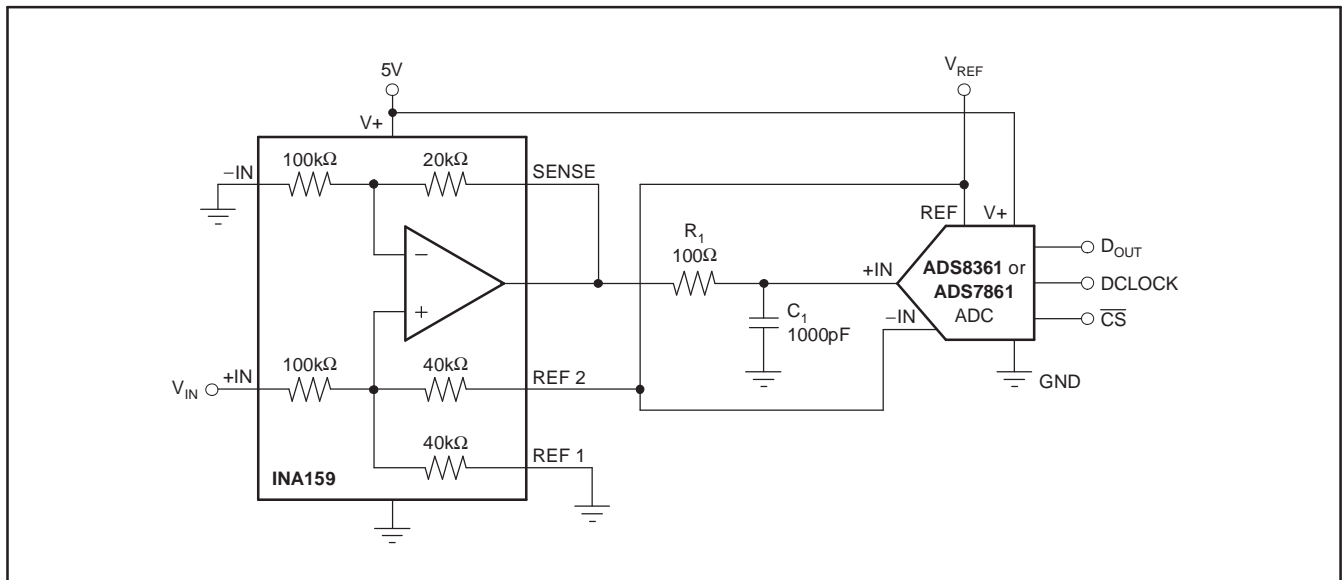

Figure 4. Typical Application Circuit Interfacing to Medium-Speed, Single-Supply ADCs with Pseudo-Differential Inputs (such as the ADS7861 and ADS8361)

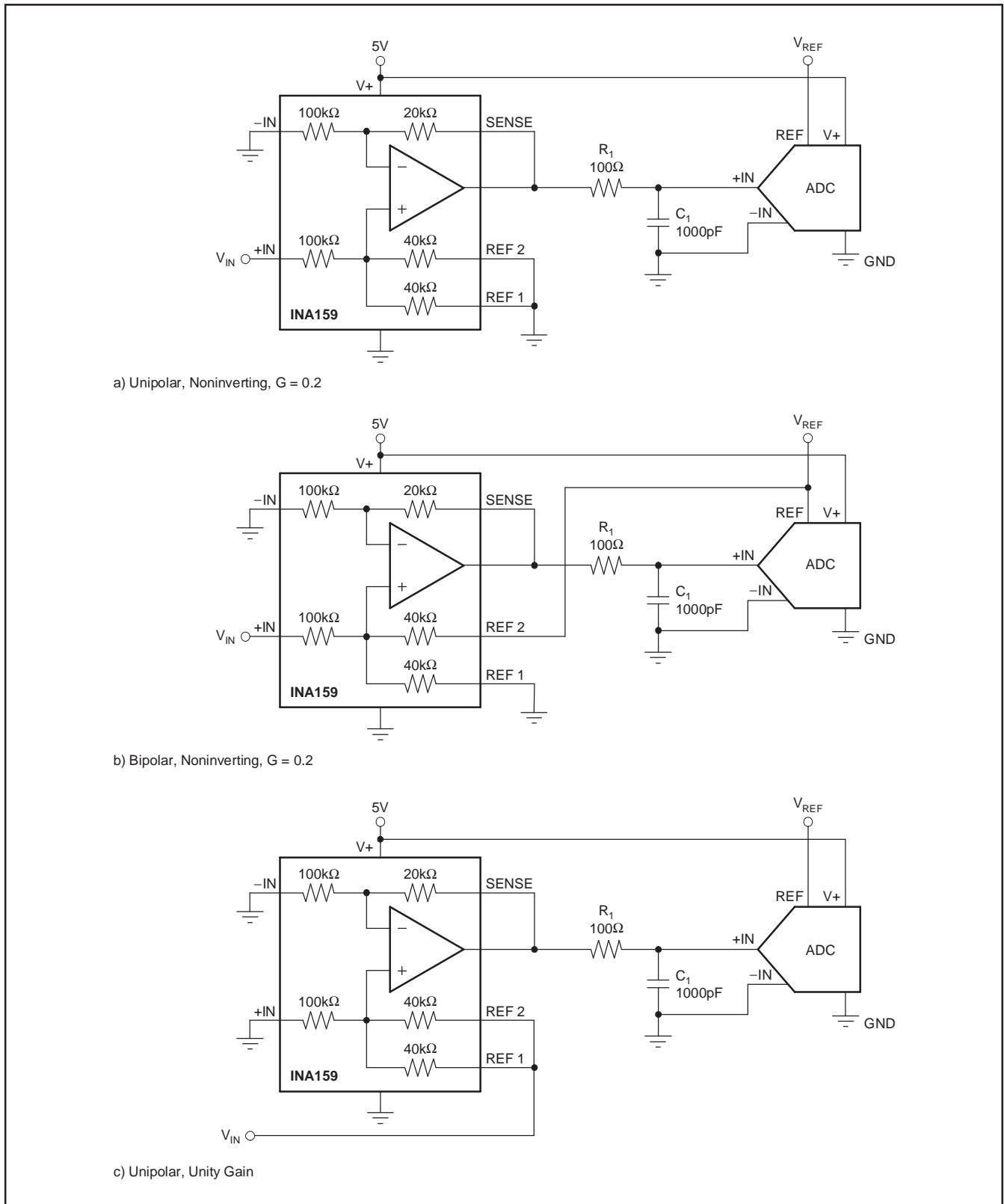

Figure 5. Basic INA159 Configurations

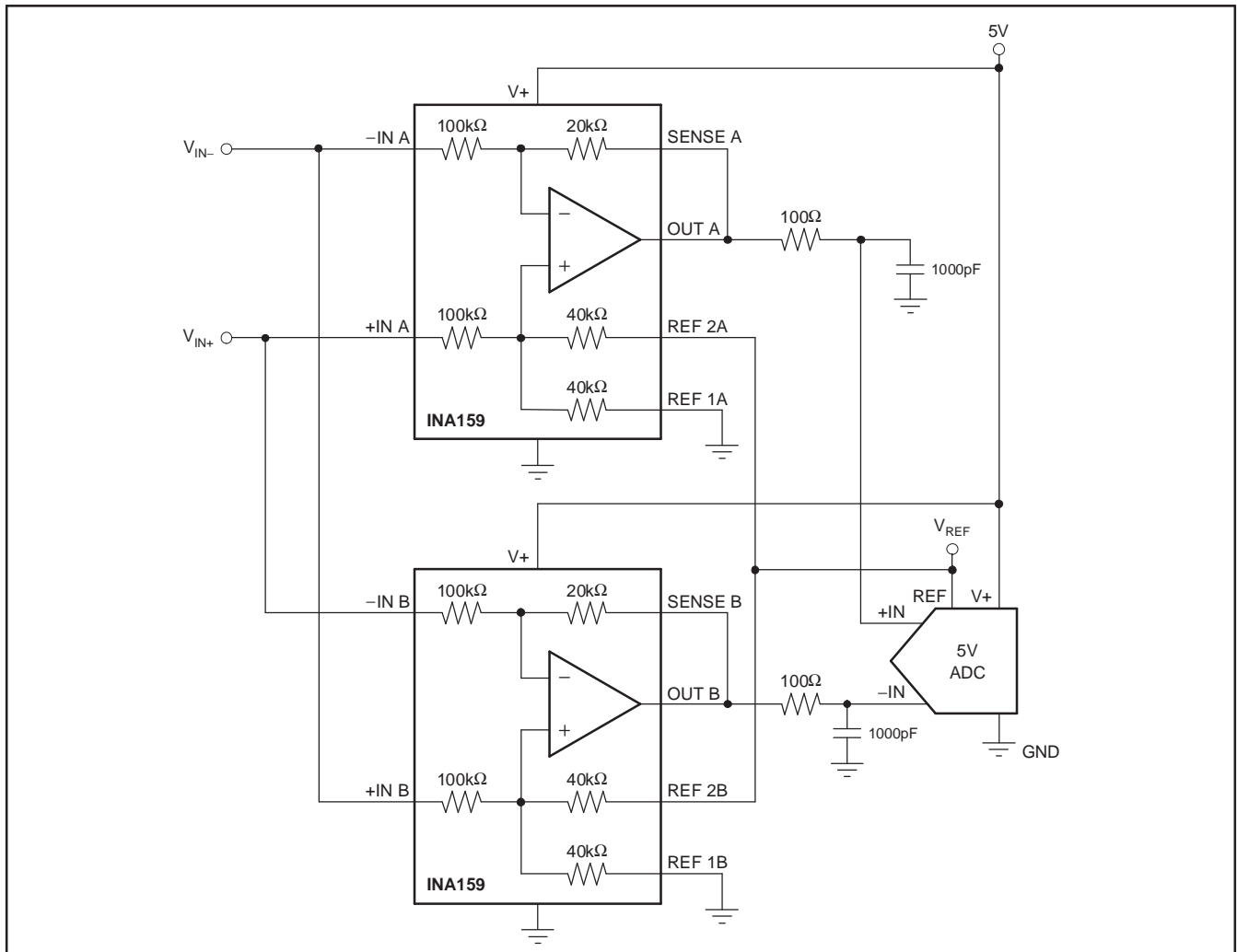

Figure 6. Differential ADC Drive

PACKAGING INFORMATION

Orderable Device	Status (1)	Package Type	Package Drawing	Pins	Package Qty	Eco Plan (2)	Lead/Ball Finish	MSL Peak Temp (3)	Op Temp (°C)	Top-Side Markings (4)	Samples
INA159AMDGKTEP	ACTIVE	VSSOP	DGK	8	250	Green (RoHS & no Sb/Br)	CU NIPDAUAG	Level-1-260C-UNLIM	-55 to 125	OAA	Samples
V62/09613-01XE	ACTIVE	VSSOP	DGK	8	250	Green (RoHS & no Sb/Br)	CU NIPDAUAG	Level-1-260C-UNLIM	-55 to 125	OAA	Samples

(1) The marketing status values are defined as follows:

ACTIVE: Product device recommended for new designs.

LIFEBUY: TI has announced that the device will be discontinued, and a lifetime-buy period is in effect.

NRND: Not recommended for new designs. Device is in production to support existing customers, but TI does not recommend using this part in a new design.

PREVIEW: Device has been announced but is not in production. Samples may or may not be available.

OBsolete: TI has discontinued the production of the device.

(2) Eco Plan - The planned eco-friendly classification: Pb-Free (RoHS), Pb-Free (RoHS Exempt), or Green (RoHS & no Sb/Br) - please check <http://www.ti.com/productcontent> for the latest availability information and additional product content details.

TBD: The Pb-Free/Green conversion plan has not been defined.

Pb-Free (RoHS): TI's terms "Lead-Free" or "Pb-Free" mean semiconductor products that are compatible with the current RoHS requirements for all 6 substances, including the requirement that lead not exceed 0.1% by weight in homogeneous materials. Where designed to be soldered at high temperatures, TI Pb-Free products are suitable for use in specified lead-free processes.

Pb-Free (RoHS Exempt): This component has a RoHS exemption for either 1) lead-based flip-chip solder bumps used between the die and package, or 2) lead-based die adhesive used between the die and leadframe. The component is otherwise considered Pb-Free (RoHS compatible) as defined above.

Green (RoHS & no Sb/Br): TI defines "Green" to mean Pb-Free (RoHS compatible), and free of Bromine (Br) and Antimony (Sb) based flame retardants (Br or Sb do not exceed 0.1% by weight in homogeneous material)

(3) MSL, Peak Temp. -- The Moisture Sensitivity Level rating according to the JEDEC industry standard classifications, and peak solder temperature.

(4) Multiple Top-Side Markings will be inside parentheses. Only one Top-Side Marking contained in parentheses and separated by a "~" will appear on a device. If a line is indented then it is a continuation of the previous line and the two combined represent the entire Top-Side Marking for that device.

Important Information and Disclaimer: The information provided on this page represents TI's knowledge and belief as of the date that it is provided. TI bases its knowledge and belief on information provided by third parties, and makes no representation or warranty as to the accuracy of such information. Efforts are underway to better integrate information from third parties. TI has taken and continues to take reasonable steps to provide representative and accurate information but may not have conducted destructive testing or chemical analysis on incoming materials and chemicals. TI and TI suppliers consider certain information to be proprietary, and thus CAS numbers and other limited information may not be available for release.

In no event shall TI's liability arising out of such information exceed the total purchase price of the TI part(s) at issue in this document sold by TI to Customer on an annual basis.

OTHER QUALIFIED VERSIONS OF INA159-EP :

- Catalog: [INA159](#)

NOTE: Qualified Version Definitions:

- Catalog - TI's standard catalog product

TAPE AND REEL INFORMATION



QUADRANT ASSIGNMENTS FOR PIN 1 ORIENTATION IN TAPE

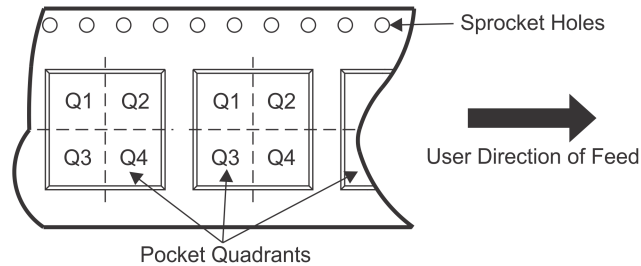

*All dimensions are nominal

Device	Package Type	Package Drawing	Pins	SPQ	Reel Diameter (mm)	Reel Width W1 (mm)	A0 (mm)	B0 (mm)	K0 (mm)	P1 (mm)	W (mm)	Pin1 Quadrant
INA159AMDGKTEP	VSSOP	DGK	8	250	180.0	12.4	5.3	3.4	1.4	8.0	12.0	Q1

TAPE AND REEL BOX DIMENSIONS



*All dimensions are nominal

Device	Package Type	Package Drawing	Pins	SPQ	Length (mm)	Width (mm)	Height (mm)
INA159AMDGKTEP	VSSOP	DGK	8	250	210.0	185.0	35.0

DGK (S-PDSO-G8)

PLASTIC SMALL-OUTLINE PACKAGE

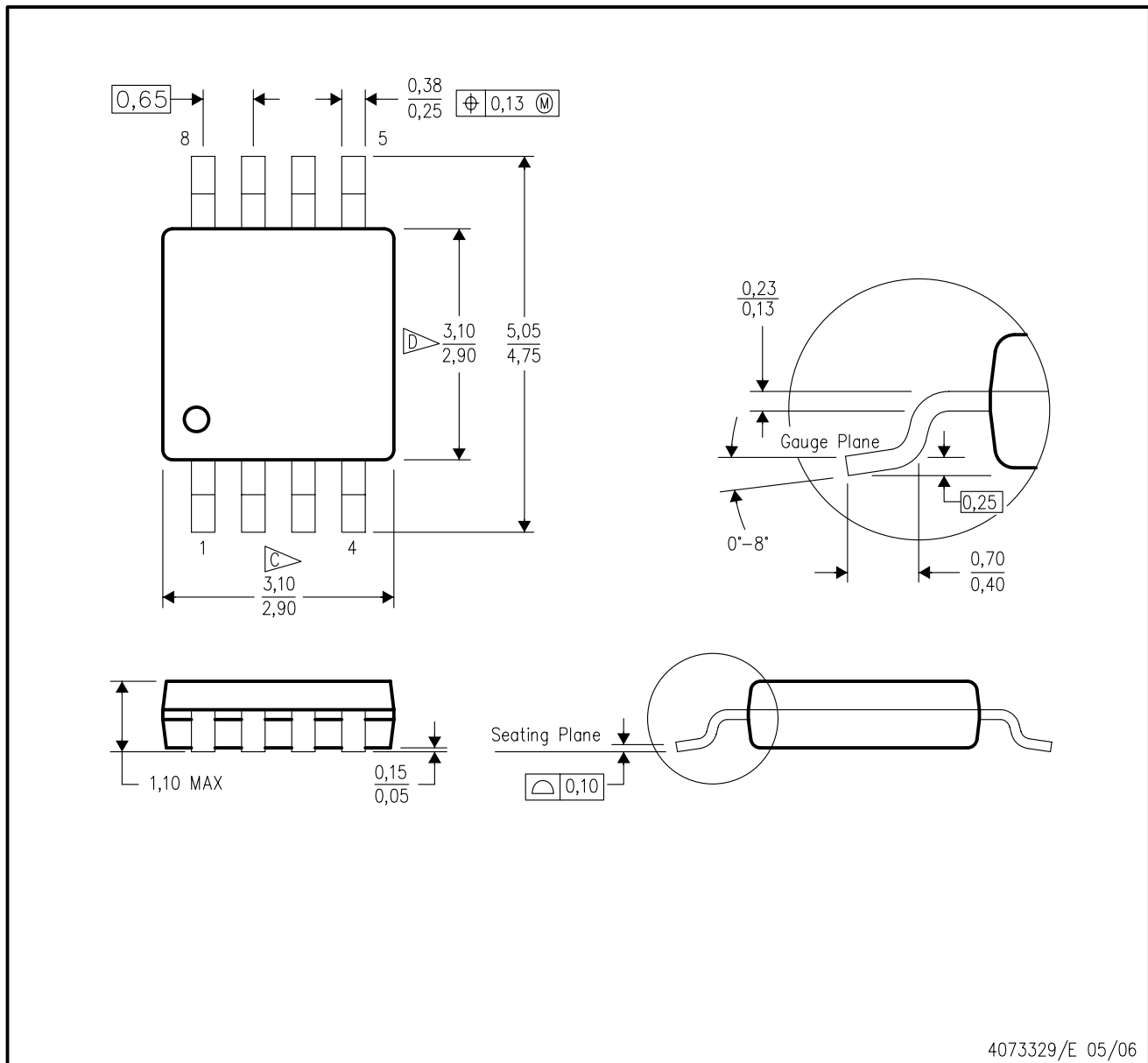

- NOTES:
- A. All linear dimensions are in millimeters.
 - B. This drawing is subject to change without notice.
 - C. Body length does not include mold flash, protrusions, or gate burrs. Mold flash, protrusions, or gate burrs shall not exceed 0.15 per end.
 - D. Body width does not include interlead flash. Interlead flash shall not exceed 0.50 per side.
 - E. Falls within JEDEC MO-187 variation AA, except interlead flash.



- NOTES:
- A. All linear dimensions are in millimeters.
 - B. This drawing is subject to change without notice.
 - C. Publication IPC-7351 is recommended for alternate designs.
 - D. Laser cutting apertures with trapezoidal walls and also rounding corners will offer better paste release. Customers should contact their board assembly site for stencil design recommendations. Refer to IPC-7525 for other stencil recommendations.
 - E. Customers should contact their board fabrication site for solder mask tolerances between and around signal pads.

IMPORTANT NOTICE

Texas Instruments Incorporated and its subsidiaries (TI) reserve the right to make corrections, enhancements, improvements and other changes to its semiconductor products and services per JESD46, latest issue, and to discontinue any product or service per JESD48, latest issue. Buyers should obtain the latest relevant information before placing orders and should verify that such information is current and complete. All semiconductor products (also referred to herein as "components") are sold subject to TI's terms and conditions of sale supplied at the time of order acknowledgment.

TI warrants performance of its components to the specifications applicable at the time of sale, in accordance with the warranty in TI's terms and conditions of sale of semiconductor products. Testing and other quality control techniques are used to the extent TI deems necessary to support this warranty. Except where mandated by applicable law, testing of all parameters of each component is not necessarily performed.

TI assumes no liability for applications assistance or the design of Buyers' products. Buyers are responsible for their products and applications using TI components. To minimize the risks associated with Buyers' products and applications, Buyers should provide adequate design and operating safeguards.

TI does not warrant or represent that any license, either express or implied, is granted under any patent right, copyright, mask work right, or other intellectual property right relating to any combination, machine, or process in which TI components or services are used. Information published by TI regarding third-party products or services does not constitute a license to use such products or services or a warranty or endorsement thereof. Use of such information may require a license from a third party under the patents or other intellectual property of the third party, or a license from TI under the patents or other intellectual property of TI.

Reproduction of significant portions of TI information in TI data books or data sheets is permissible only if reproduction is without alteration and is accompanied by all associated warranties, conditions, limitations, and notices. TI is not responsible or liable for such altered documentation. Information of third parties may be subject to additional restrictions.

Resale of TI components or services with statements different from or beyond the parameters stated by TI for that component or service voids all express and any implied warranties for the associated TI component or service and is an unfair and deceptive business practice. TI is not responsible or liable for any such statements.

Buyer acknowledges and agrees that it is solely responsible for compliance with all legal, regulatory and safety-related requirements concerning its products, and any use of TI components in its applications, notwithstanding any applications-related information or support that may be provided by TI. Buyer represents and agrees that it has all the necessary expertise to create and implement safeguards which anticipate dangerous consequences of failures, monitor failures and their consequences, lessen the likelihood of failures that might cause harm and take appropriate remedial actions. Buyer will fully indemnify TI and its representatives against any damages arising out of the use of any TI components in safety-critical applications.

In some cases, TI components may be promoted specifically to facilitate safety-related applications. With such components, TI's goal is to help enable customers to design and create their own end-product solutions that meet applicable functional safety standards and requirements. Nonetheless, such components are subject to these terms.

No TI components are authorized for use in FDA Class III (or similar life-critical medical equipment) unless authorized officers of the parties have executed a special agreement specifically governing such use.

Only those TI components which TI has specifically designated as military grade or "enhanced plastic" are designed and intended for use in military/aerospace applications or environments. Buyer acknowledges and agrees that any military or aerospace use of TI components which have **not** been so designated is solely at the Buyer's risk, and that Buyer is solely responsible for compliance with all legal and regulatory requirements in connection with such use.

TI has specifically designated certain components as meeting ISO/TS16949 requirements, mainly for automotive use. In any case of use of non-designated products, TI will not be responsible for any failure to meet ISO/TS16949.

Products

Audio	www.ti.com/audio
Amplifiers	amplifier.ti.com
Data Converters	dataconverter.ti.com
DLP® Products	www.dlp.com
DSP	dsp.ti.com
Clocks and Timers	www.ti.com/clocks
Interface	interface.ti.com
Logic	logic.ti.com
Power Mgmt	power.ti.com
Microcontrollers	microcontroller.ti.com
RFID	www.ti-rfid.com
OMAP Applications Processors	www.ti.com/omap
Wireless Connectivity	www.ti.com/wirelessconnectivity

Applications

Automotive and Transportation	www.ti.com/automotive
Communications and Telecom	www.ti.com/communications
Computers and Peripherals	www.ti.com/computers
Consumer Electronics	www.ti.com/consumer-apps
Energy and Lighting	www.ti.com/energy
Industrial	www.ti.com/industrial
Medical	www.ti.com/medical
Security	www.ti.com/security
Space, Avionics and Defense	www.ti.com/space-avionics-defense
Video and Imaging	www.ti.com/video

TI E2E Community

e2e.ti.com

Looking for pricing, stock, or lifecycle information?

Click below to explore more details on WIN SOURCE:

⊖ [View INA159AMDGKTEP](#) on WIN SOURCE

⊖ [Texas Instruments](#) Information

Optimize Your Supply Chain with WIN SOURCE Solutions

- ✓ Global Sourcing Solution
- ✓ Obsolete Management
- ✓ Cost Control Management
- ✓ Shortage Management
- ✓ Alternative Solution
- ✓ Excess Inventory Management