



**THE DATASHEET OF
CY26121ZC-21**



PacketClock™ Spread Spectrum Clock Generator

Features

- Integrated phase-locked loop (PLL)
- Low jitter, high-accuracy outputs
- 3.3V operation
- 25-MHz input frequency
- 66.66-MHz or 33.33-MHz selectable output frequency (orig, -3,-11,-31)
- 33.33-MHz or 25-MHz selectable output frequency (-2,-21)

Benefits

- High-performance PLL tailored for Spread Spectrum application
- Meets critical timing requirements in complex system designs
- Enables application compatibility
- Works with commonly available crystal or driven reference
- Downspread Spread Spectrum with 30-kHz nominal modulation frequency

Table 1. Frequency Table for CLKA-D

Part Number	CLKSEL=0	CLKSEL=1	Spread%	Parallel Crystal Load
CY26121	66.66 MHz	33.33	-2.8%	6 pF
CY26121-2	33.33 MHz	25.00	-2.8%	6 pF
CY26121-3	66.66 MHz	33.33	-1.4%	6 pF
CY26121-11	66.66 MHz	33.33	-2.8%	15 pF
CY26121-21	33.33 MHz	25.00	-2.8%	15 pF
CY26121-31	66.66 MHz	33.33	-1.4%	15 pF

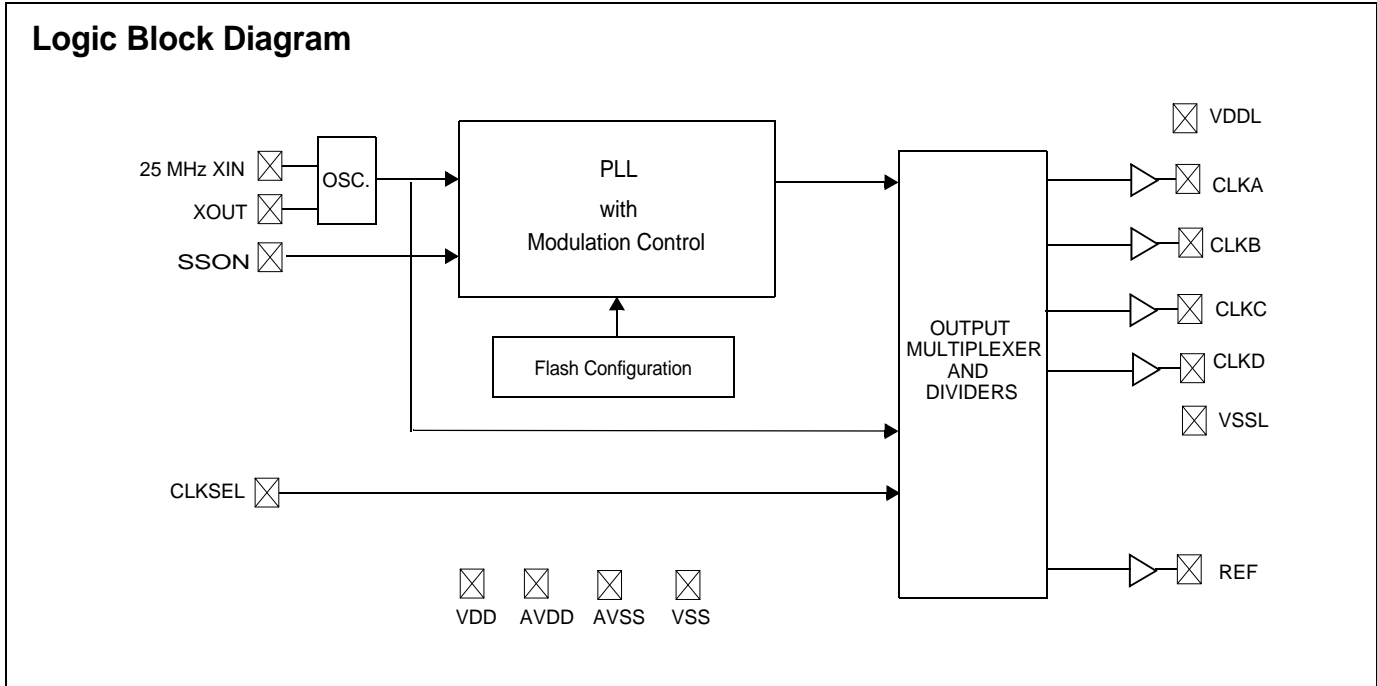

Pin Configuration

Figure 1. CY26121, 16-pin TSSOP

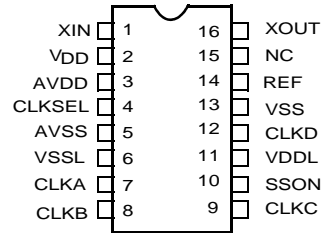

Table 2. Pin Definitions

Name	Pin Number	Description
XIN	1	Reference input Or Crystal Input
VDD	2	3.3V Voltage Supply
AVDD	3	3.3V Analog Voltage
CLKSEL	4 (orig., -11,-3,-31)	0 = 66.66MHz out, 1 = 33.33 MHz Out. Weak pull up.
CLKSEL	4 (-2, -21)	0 = 33.33MHz out, 1 = 25 MHz Out. Weak pull up.
AVSS	5	Analog Ground
VSSL	6	CLK Ground
CLK(A:D)	7,8,9,12	Clock Outputs at V _{DDL} level
SSON	10	Spread Spectrum Enable pin 0 = SS off; 1 = SS on. Weak pull up.
VDDL	11	3.3V Clock Voltage Supply
VSS	13	Ground
REF	14	Reference Output at V _{DD} Level
NC	15	No Connect
XOUT ^[1]	16	Crystal Output

Maximum Ratings

Exceeding maximum ratings may impair the useful life of the device. These user guidelines are not tested.

Supply Voltage (V_{DD} , AV_{DD} , V_{DDL}) -0.5 to +7.0V
 DC Input Voltage -0.5V to $V_{DD} + 0.5$
 Storage Temperature
 (Non-condensing) -55°C to +125°C

Junction Temperature -40°C to +125°C
 Data Retention at $T_j = 125^\circ\text{C}$ > 10 years
 Package Power Dissipation 350 mW
 Static Discharge Voltage $\geq 2000\text{V}$
 (per MIL-STD-883, Method 3015)

Recommended Operating Conditions

Parameter	Description	Min	Typ.	Max	Unit
V_{DD} , AV_{DD}	Supply voltage	3.135	3.30	3.465	V
V_{DDL}	Supply voltage for CLK (A-D)	3.135	3.30	3.465	V
T_A	Ambient temperature (commercial temp. grade)	0		70	°C
T_A	Ambient Temperature (industrial temp grade)	-40		85	°C
C_{LOAD}	Max. output load capacitance			15	pF
F_{ref}	Reference frequency		25		MHz

Crystal Specification^[2]

Parameter	Name	Min	Typ	Max	Unit
CR_{load}	Crystal load capacitance (original, -2, -3)		6		pF
CR_{load}	Crystal load capacitance (-11,-21,-31)		15		pF
ESR	Equivalent series resistance			50	Ω

DC Electrical Specifications

Parameter	Description	Condition	Min	Typ.	Max	Unit
I_{OH}	Output High Current	$V_{OH} = V_{DD} - 0.5$, $V_{DD}/V_{DDL}=3.3\text{V}$	12	24		mA
I_{OL}	Output Low Current	$V_{OL} = 0.5$, $V_{DD}/V_{DDL} = 3.3\text{V}$	12	24		mA
I_{IH}	Input High Current	$V_{IH} = V_{DD}$		5	10	μA
I_{IL}	Input Low Current	$V_{IL} = 0\text{V}$			50	μA
V_{IH}	Input High Voltage	CMOS levels	0.7			V_{DD}
V_{IL}	Input Low Voltage	CMOS levels			0.3	V_{DD}
$C_{IN}^{[3]}$	Input Capacitance	Input pins excluding XIN			7	pF
$R_{UP}^{[3]}$	Pull up resistor on input pins	$V_{DD} = 3.14$ to 3.47V , measured at $V_{IN} = 0\text{V}$	80	100	150	k Ω
I_{DD}	Supply Current	$AV_{DD}/V_{DD}/V_{DDL}$ Current.		42	60	mA

Notes

1. Float XOUT if XIN is externally driven.
2. A fundamental parallel resonant crystal must be used

AC Electrical Specifications^[3]

Parameter	Description	Condition	Min	Typ.	Max	Unit
DC	Output Duty Cycle	Duty Cycle is defined in Figure 2, 50% of V _{DD}	45	50	55	%
ER	Rising Edge Rate	Output Clock Edge Rate, Measured from 20% to 80% of V _{DD} , C _{LOAD} = 15 pF See Figure 3.	0.8	1.4		V/ns
EF	Falling Edge Rate	Output Clock Edge Rate, Measured from 80% to 20% of V _{DD} , C _{LOAD} = 15 pF See Figure 3.	0.8	1.4		V/ns
tj	RMS Clock Cycle-to-Cycle Jitter	RMS cycle-to-cycle jitter with Spread on. Measured at V _{DD} /2.		15	40	ps

Voltage and Timing Definitions

Figure 2. Duty Cycle Definition

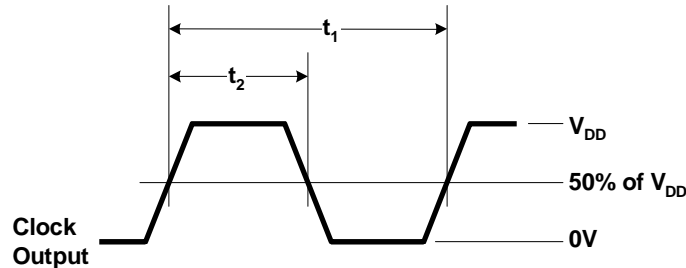
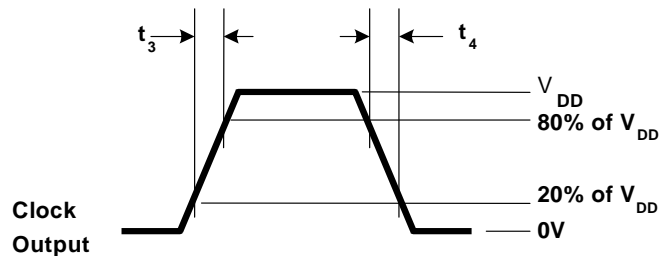

Figure 3. ER = (0.6 x V_{DD}) / t3, EF = (0.6 x V_{DD}) / t4



Note

3. Guaranteed by Characterization, not 100% tested.

Ordering Information

Ordering Code	Package Type	Operating Range
CY26121ZC ^[4]	16-pin TSSOP	Commercial, 0°C to 70°C
CY26121ZCT ^[4]	16-pin TSSOP – Tape and Reel	Commercial, 0°C to 70°C
CY26121ZI ^[4]	16-pin TSSOP	Industrial, –40°C to 85°C
CY26121ZIT ^[4]	16-pin TSSOP – Tape and Reel	Industrial, –40°C to 85°C
CY26121ZC-2 ^[4]	16-pin TSSOP	Commercial, 0°C to 70°C
CY26121ZC-2T ^[4]	16-pin TSSOP – Tape and Reel	Commercial, 0°C to 70°C
CY26121ZI-2 ^[4]	16-pin TSSOP	Industrial, –40°C to 85°C
CY26121ZI-2T ^[4]	16-pin TSSOP – Tape and Reel	Industrial, –40°C to 85°C
CY26121ZC-3 ^[4]	16-pin TSSOP	Commercial, 0°C to 70°C
CY26121ZC-3T ^[4]	16-pin TSSOP – Tape and Reel	Commercial, 0°C to 70°C
CY26121ZI-3 ^[4]	16-pin TSSOP	Industrial, –40°C to 85°C
CY26121ZI-3T ^[4]	16-pin TSSOP – Tape and Reel	Industrial, –40°C to 85°C
CY26121ZC-11 ^[4]	16-pin TSSOP	Commercial, 0°C to 70°C
CY26121ZC-11T ^[4]	16-pin TSSOP – Tape and Reel	Commercial, 0°C to 70°C
CY26121ZC-21 ^[4]	16-pin TSSOP	Commercial, 0°C to 70°C
CY26121ZC-21T ^[4]	16-pin TSSOP – Tape and Reel	Commercial, 0°C to 70°C
CY26121ZI-21 ^[4]	16-pin TSSOP	Industrial, –40°C to 85°C
CY26121ZI-21T ^[4]	16-pin TSSOP – Tape and Reel	Industrial, –40°C to 85°C
CY26121ZC-31 ^[4]	16-pin TSSOP	Commercial, 0°C to 70°C
CY26121ZC-31T ^[4]	16-pin TSSOP – Tape and Reel	Commercial, 0°C to 70°C
CY26121KZC-21	16-pin TSSOP	Commercial, 0°C to 70°C
CY26121KZC-21T	16-pin TSSOP – Tape and Reel	Commercial, 0°C to 70°C
CY26121KZI-21	16-pin TSSOP	Industrial, –40°C to 85°C
CY26121KZI-21T	16-pin TSSOP – Tape and Reel	Industrial, –40°C to 85°C
Pb-Free		
CY26121ZXC-21 ^[4]	16-pin TSSOP	Commercial, 0°C to 70°C
CY26121ZXC-21T ^[4]	16-pin TSSOP – Tape and Reel	Commercial, 0°C to 70°C
CY26121ZXI-21 ^[4]	16-pin TSSOP	Industrial, –40°C to 85°C
CY26121ZXI-21T ^[4]	16-pin TSSOP – Tape and Reel	Industrial, –40°C to 85°C
CY26121KZXC-21	16-pin TSSOP	Commercial, 0°C to 70°C
CY26121KZXC-21T	16-pin TSSOP – Tape and Reel	Commercial, 0°C to 70°C
CY26121KZXI-21	16-pin TSSOP	Industrial, –40°C to 85°C
CY26121KZXI-21T	16-pin TSSOP – Tape and Reel	Industrial, –40°C to 85°C

Note

4. Not recommended for new designs.

Package Drawing and Dimensions

Figure 4. 16-lead Thin Shrunk Small Outline Package (4.40 MM Body) Z16

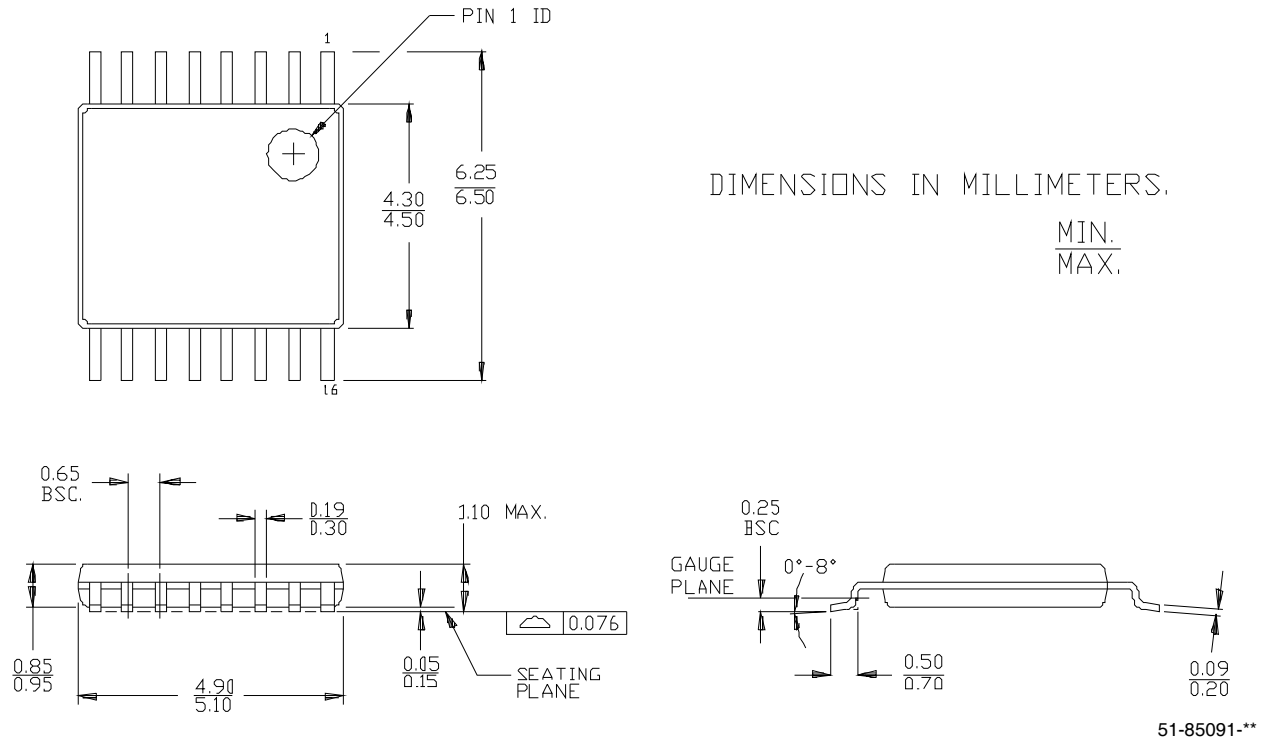

Parameter	Inches			Millimeters		
	Min	Nom.	Max	Min	Nom.	Max.
A	-	-	0.047	-	-	1.20
A ₁	0.002	-	0.006	0.05	-	0.15
A ₂	0.031	0.039	0.041	0.80	1.00	1.05
B	0.007	-	0.012	0.19	-	0.30
C	0.004	-	0.008	0.09	-	0.20
D	0.193	0.197	0.201	4.90	5.00	5.10
E	0.169	0.173	0.177	4.30	4.40	4.50
e	0.026 BSC			0.65 BSC		
H	0.244	0.252	0.260	6.20	6.40	6.60
L	0.018	0.024	0.030	0.45	0.60	0.75
a	0°	-	8°	0°	-	8°

Document History Page

Document Title: CY26121 PacketClock™ Spread Spectrum Clock Generator				
Document Number: 38-07350				
REV.	ECN NO.	Issue Date	Orig. of Change	Description of Change
**	121669	02/11/03	CKN	New Data Sheet
*A	2440886	See ECN	KVM/AESA	Updated template. Added Note "Not recommended for new designs." Added part numbers CY26121ZXC-21, CY26121ZXC-21T, CY26121ZXI-21, and CY26121ZXI-21T in ordering information table. Added part numbers CY26121KZC-21, CY26121KZC-21T, CY26121KZI-21, and CY26121KZI-21T. Added part numbers CY26121KZXC-21, CY26121KZXC-21T, CY26121KZXI-21, and CY26121KZXI-21T. Removed part numbers CY26121ZI-11, CY26121ZI-11T, CY26121ZI-31 and CY26121ZI-31T

Sales, Solutions, and Legal Information

Worldwide Sales and Design Support

Cypress maintains a worldwide network of offices, solution centers, manufacturer's representatives, and distributors. To find the office closest to you, visit us at cypress.com/sales.

Products

PSoC	psoc.cypress.com
Clocks & Buffers	clocks.cypress.com
Wireless	wireless.cypress.com
Memories	memory.cypress.com
Image Sensors	image.cypress.com

PSoC Solutions

General	psoc.cypress.com/solutions
Low Power/Low Voltage	psoc.cypress.com/low-power
Precision Analog	psoc.cypress.com/precision-analog
LCD Drive	psoc.cypress.com/lcd-drive
CAN 2.0b	psoc.cypress.com/can
USB	psoc.cypress.com/usb

© Cypress Semiconductor Corporation, 2003-2008. The information contained herein is subject to change without notice. Cypress Semiconductor Corporation assumes no responsibility for the use of any circuitry other than circuitry embodied in a Cypress product. Nor does it convey or imply any license under patent or other rights. Cypress products are not warranted nor intended to be used for medical, life support, life saving, critical control or safety applications, unless pursuant to an express written agreement with Cypress. Furthermore, Cypress does not authorize its products for use as critical components in life-support systems where a malfunction or failure may reasonably be expected to result in significant injury to the user. The inclusion of Cypress products in life-support systems application implies that the manufacturer assumes all risk of such use and in doing so indemnifies Cypress against all charges.

Any Source Code (software and/or firmware) is owned by Cypress Semiconductor Corporation (Cypress) and is protected by and subject to worldwide patent protection (United States and foreign), United States copyright laws and international treaty provisions. Cypress hereby grants to licensee a personal, non-exclusive, non-transferable license to copy, use, modify, create derivative works of, and compile the Cypress Source Code and derivative works for the sole purpose of creating custom software and/or firmware in support of licensee product to be used only in conjunction with a Cypress integrated circuit as specified in the applicable agreement. Any reproduction, modification, translation, compilation, or representation of this Source Code except as specified above is prohibited without the express written permission of Cypress.

Disclaimer: CYPRESS MAKES NO WARRANTY OF ANY KIND, EXPRESS OR IMPLIED, WITH REGARD TO THIS MATERIAL, INCLUDING, BUT NOT LIMITED TO, THE IMPLIED WARRANTIES OF MERCHANTABILITY AND FITNESS FOR A PARTICULAR PURPOSE. Cypress reserves the right to make changes without further notice to the materials described herein. Cypress does not assume any liability arising out of the application or use of any product or circuit described herein. Cypress does not authorize its products for use as critical components in life-support systems where a malfunction or failure may reasonably be expected to result in significant injury to the user. The inclusion of Cypress' product in a life-support systems application implies that the manufacturer assumes all risk of such use and in doing so indemnifies Cypress against all charges.

Use may be limited by and subject to the applicable Cypress software license agreement.

Looking for pricing, stock, or lifecycle information?

Click below to explore more details on WIN SOURCE:

 [View CY26121ZC-21 on WIN SOURCE](#)

 [Infineon Technologies](#) Information

Optimize Your Supply Chain with WIN SOURCE Solutions

-  Global Sourcing Solution
-  Obsolete Management
-  Cost Control Management
-  Shortage Management
-  Alternative Solution
-  Excess Inventory Management