



THE DATASHEET OF CD4066BF



CD4066B CMOS Quad Bilateral Switch

1 Features

- 15V digital or $\pm 7.5V$ peak-to-peak switching
- 125 Ω typical on-state resistance for 15V operation
- Switch on-state resistance matched to within 5 Ω over 15V signal-input range
- On-state resistance flat over full peak-to-peak signal range
- High on or off output-voltage ratio: 80dB typical at $f_{is} = 10\text{kHz}$, $R_L = 1\text{k}\Omega$
- High degree of linearity: <0.5% distortion typical at $f_{is} = 1\text{kHz}$, $V_{is} = 5V_{p-p}$, $V_{DD} - V_{SS} \geq 10V$, $R_L = 10\text{k}\Omega$
- Extremely low off-state switch leakage, resulting in very low offset current and high effective off-state resistance: 10 pA typical at $V_{DD} - V_{SS} = 10V$, $T_A = 25^\circ\text{C}$
- Extremely high control input impedance (control circuit isolated from signal circuit): 10¹² Ω typical
- Low crosstalk between switches: -50dB typical at $f_{is} = 8\text{MHz}$, $R_L = 1\text{k}\Omega$
- Matched control-input to signal-output capacitance: reduces output signal transients
- Frequency response, switch On = 40MHz typical
- 100% tested for quiescent current at 20V, 5V, 10V, and 15V parametric ratings

2 Applications

- Analog signal switching and multiplexing: signal gating, modulators, squelch controls, demodulators, choppers, commutating switches
- Digital signal switching and multiplexing
- Analog-to-digital and digital-to-analog conversions
- Digital control of frequency, impedance, phase, and analog-signal gain
- [Building automation](#)

3 Description

The CD4066B device is a quad bilateral switch intended for the transmission or multiplexing of analog or digital signals. It is pin-for-pin compatible with the CD4016B device, but exhibits a much lower on-state resistance. In addition, the on-state resistance is relatively constant over the full signal-input range.

The CD4066B device consists of four bilateral switches, each with independent controls. Wide operating supply of 3V to 18V allows for use in a broad array of applications. The advantages over single-channel switches include peak input-signal voltage swings equal to the full supply voltage and more constant on-state impedance over the input-signal range. However, for sample-and-hold applications, the CD4016B device is recommended.

Package Information

PART NUMBER	PACKAGE ⁽¹⁾	PACKAGE SIZE ⁽²⁾
CD4066B	N (PDIP, 14)	19.3mm × 9.4mm
	D (SOIC, 14)	8.65mm × 6mm
	NS (SOP, 14)	10.2mm × 7.8mm
	PW (TSSOP, 14)	5mm × 6.4mm

- (1) For more information, see [Section 11](#)
- (2) The package size (length × width) is a nominal value and includes pins, where applicable.

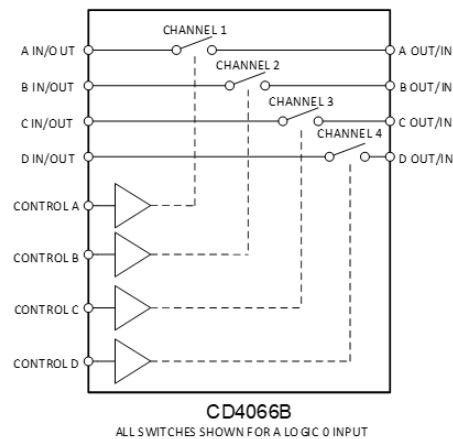

Bidirectional Signal Transmission Through Digital Control Logic



Table of Contents

1 Features	1	7.3 Feature Description.....	13
2 Applications	1	7.4 Device Functional Modes.....	14
3 Description	1	8 Application and Implementation	15
4 Pin Configuration and Functions	2	8.1 Application Information.....	15
5 Specifications	3	8.2 Typical Application.....	15
5.1 Absolute Maximum Ratings.....	3	8.3 Power Supply Recommendations.....	16
5.2 ESD Ratings.....	3	8.4 Layout.....	16
5.3 Recommended Operating Conditions.....	3	9 Device and Documentation Support	17
5.4 Thermal Information.....	4	9.1 Receiving Notification of Documentation Updates....	17
5.5 Electrical Characteristics.....	4	9.2 Support Resources.....	17
5.6 Switching Characteristics.....	7	9.3 Trademarks.....	17
5.7 Typical Characteristics.....	8	9.4 Electrostatic Discharge Caution.....	17
6 Parameter Measurement Information	9	9.5 Glossary.....	17
7 Detailed Description	13	10 Revision History	17
7.1 Overview.....	13	11 Mechanical, Packaging, and Orderable Information	17
7.2 Functional Block Diagram.....	13		

4 Pin Configuration and Functions

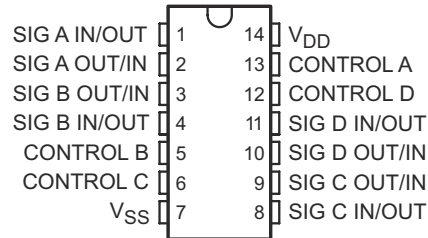

Figure 4-1. N, J, D, NS, or PW Packages 14-Pin PDIP, CDIP, SOIC, SOP, or TSSOP (Top View)

Table 4-1. Pin Functions

PIN		TYPE ⁽¹⁾	DESCRIPTION
NAME	NO.		
SIG A IN/OUT	1	I/O	Input/Output for Switch A
SIG A OUT/IN	2	I/O	Output/Input for Switch A
SIG B OUT/IN	3	I/O	Output/Input for Switch B
SIG B IN/OUT	4	I/O	Input/Output for Switch B
CONTROL B	5	I	Control pin for Switch B
CONTROL C	6	I	Control pin for Switch C
V _{SS}	7	—	Low Voltage Power Pin
SIG C IN/OUT	8	I/O	Input/Output for Switch C
SIG C OUT/IN	9	I/O	Output/Input for Switch C
SIG D OUT/IN	10	I/O	Output/Input for Switch D
SIG D IN/OUT	11	I/O	Input/Output for Switch D
CONTROL D	12	I	Control Pin for D
CONTROL A	13	I	Control Pin for A
V _{DD}	14	—	Power Pin

(1) I = input, O = output

5 Specifications

5.1 Absolute Maximum Ratings

over operating free-air temperature range (unless otherwise noted)⁽¹⁾ ⁽²⁾

		MIN	MAX	UNIT
$V_{DD} - V_{SS}$	Supply voltage		20	V
V_{DD}		-0.5	20	V
V_{SS}		-20	0.5	V
I_{SEL} or I_{EN}	Logic control input pin current (\overline{EN} , Ax, SELx)	-30	30	mA
V_S or V_D	Source or drain voltage (Sx, D)	$V_{SS}-0.5$	$V_{DD}+0.5$	V
I_S or I_D (CONT)	Source or drain continuous current (Sx, D)	-20	20	mA
T_J	Junction temperature		150	°C
T_{stg}	Storage temperature	-65	150	°C

- (1) Stresses beyond those listed under *Absolute Maximum Rating* may cause permanent damage to the device. These are stress ratings only, which do not imply functional operation of the device at these or any other conditions beyond those indicated under *Recommended Operating Condition*. Exposure to absolute-maximum-rated conditions for extended periods may affect device reliability.
- (2) All voltages are with respect to ground, unless otherwise specified.

5.2 ESD Ratings

		VALUE	UNIT
$V_{(ESD)}$	Electrostatic discharge	Human body model (HBM), per ANSI/ESDA/JEDEC JS-001, all pins ⁽¹⁾	±500
		Charged device model (CDM), per JEDEC specification JESD22-C101, all pins ⁽²⁾	±1500

- (1) JEDEC document JEP155 states that 500V HBM allows safe manufacturing with a standard ESD control process.
- (2) JEDEC document JEP157 states that 250V CDM allows safe manufacturing with a standard ESD control process.

5.3 Recommended Operating Conditions

over operating free-air temperature range (unless otherwise noted)

		MIN	NOM	MAX	UNIT
$V_{DD} - V_{SS}$ ⁽¹⁾	Power supply voltage differential	3		18	V
V_{DD}	Positive power supply voltage	3		18	V
V_S or V_D	Signal path input/output voltage (source or drain pin) (Sx, D)	V_{SS}		V_{DD}	V
V_{SEL} or V_{EN}	Address or enable pin voltage	0		V_{DD}	V
I_S or I_D (CONT)	Source or drain continuous current (Sx, D)	-10		10	mA
T_A	Ambient temperature	-55		125	°C

- (1) V_{DD} and V_{SS} can be any value as long as $3V \leq (V_{DD} - V_{SS}) \leq 24V$, and the minimum V_{DD} is met.

5.4 Thermal Information

THERMAL METRIC ⁽¹⁾		CD406x				UNIT
		N (PDIP)	D (SOIC)	NS (SO)	PW (TSSOP)	
		14 PINS	14 PINS	14 PINS	14 PINS	
R _{θJA}	Junction-to-ambient thermal resistance	93.7	109.7	112.4	101.8	°C/W
R _{θJC(top)}	Junction-to-case (top) thermal resistance	72.5	69.4	70.4	44.3	°C/W
R _{θJB}	Junction-to-board thermal resistance	68.0	67.9	76.4	68.2	°C/W
ψ _{JT}	Junction-to-top characterization parameter	50.3	25.8	28.9	3.2	°C/W
ψ _{JB}	Junction-to-board characterization parameter	67.3	67.1	75.4	67.6	°C/W

(1) For more information about traditional and new thermal metrics, see the [Semiconductor and IC Package Thermal Metrics](#) application report.

5.5 Electrical Characteristics

Over operating free-air temperature range, V_{SUPPLY} = ±5V, and R_L = 100 Ω, (unless otherwise noted)⁽¹⁾

PARAMETER		TEST CONDITIONS		MIN	TYP	MAX	UNIT
SIGNAL INPUTS (V_{IS}) AND OUTPUTS (V_{OS})							
V _{OS}	Switch output voltage	V _{DD} = 5V V _{is} = 0V				0.4	V
		V _{DD} = 5V V _{is} = 5V			4.6		V
		V _{DD} = 10V V _{is} = 0V				0.5	V
		V _{DD} = 10V V _{is} = 10V			9.5		V
		V _{DD} = 15V V _{is} = 0V				1.5	V
		V _{DD} = 15V V _{is} = 15V			13.5		V
Δ R _{ON}	On-state resistance difference between any two switches		R _L = 10kΩ, V _C = V _{DD}	V _{DD} = 5V		15	Ω
	On-state resistance difference between any two switches	On-state resistance difference between any two switches		V _{DD} = 10V		10	
	On-state resistance difference between any two switches	On-state resistance difference between any two switches		V _{DD} = 15V		5	
V _{IHC}	Control input, high voltage		See Figure 7	V _{DD} = 5V		3.5	V
				V _{DD} = 10V		7	V
				V _{DD} = 15V		11	V
	Maximum control input repetition rate		V _{IN} = V _{DD} , C _L = 50pF, R _L = 1kΩ V _C = 10V (square wave centered on 5V), t _r , t _f = 20ns, V _{os} = 1/2V _{os} at 1kHz	V _{DD} = 5V		6	MHz
				V _{DD} = 10V		9	
				V _{DD} = 15V		9.5	

5.5 Electrical Characteristics (continued)

Over operating free-air temperature range, $V_{SUPPLY} = \pm 5V$, and $R_L = 100 \Omega$, (unless otherwise noted)⁽¹⁾

PARAMETER		TEST CONDITIONS			MIN	TYP	MAX	UNI T	
C_{IN}	Input Capacitance				5	7.5		pF	
I_{IS}	Switch input current	$V_{DD} = 5V$ $V_{IS} = 0V$	$T_A = -55^\circ C$				0.64	mA	
			$T_A = -40^\circ C$				0.61		
			$T_A = 25^\circ C$			0.51			
			$T_A = 85^\circ C$				0.42		
			$T_A = 125^\circ C$				0.36		
		$V_{DD} = 5V$ $V_{IS} = 5V$	$T_A = -55^\circ C$					-0.64	mA
			$T_A = -40^\circ C$					-0.61	
			$T_A = 25^\circ C$			-0.51			
			$T_A = 85^\circ C$					-0.42	
			$T_A = 125^\circ C$					-0.36	
		$V_{DD} = 10V$ $V_{IS} = 0V$	$T_A = -55^\circ C$					1.6	mA
			$T_A = -40^\circ C$					1.5	
			$T_A = 25^\circ C$			1.3			
			$T_A = 85^\circ C$					1.1	
			$T_A = 125^\circ C$					0.9	
		$V_{DD} = 10V$ $V_{IS} = 10V$	$T_A = -55^\circ C$					-1.6	mA
			$T_A = -40^\circ C$					-1.5	
			$T_A = 25^\circ C$			-1.3			
			$T_A = 85^\circ C$					-1.1	
			$T_A = 125^\circ C$					-0.9	
		$V_{DD} = 15V$ $V_{IS} = 0V$	$T_A = -55^\circ C$					4.2	mA
			$T_A = -40^\circ C$					4	
			$T_A = 25^\circ C$			3.4			
			$T_A = 85^\circ C$					2.8	
$T_A = 125^\circ C$						2.4			
$V_{DD} = 15V$ $V_{IS} = 15V$	$T_A = -55^\circ C$					-4.2	mA		
	$T_A = -40^\circ C$					-4			
	$T_A = 25^\circ C$			-3.4					
	$T_A = 85^\circ C$					-2.8			
	$T_A = 125^\circ C$					-2.4			

5.5 Electrical Characteristics (continued)

Over operating free-air temperature range, $V_{SUPPLY} = \pm 5V$, and $R_L = 100 \Omega$, (unless otherwise noted)⁽¹⁾

PARAMETER		TEST CONDITIONS			MIN	TYP	MAX	UNI T
I_{DD}	Quiescent Device Current All switches OFF	$V_{is} = 0$ to 5V $V_{DD} = 5V$	$T_A = -55^\circ C$				5	μA
			$T_A = -40^\circ C$				5	
			$T_A = 25^\circ C$			4	6	
			$T_A = 85^\circ C$				7	
			$T_A = 125^\circ C$				7.5	
		$V_{is} = 0$ to 10V $V_{DD} = 10V$	$T_A = -55^\circ C$				6	
			$T_A = -40^\circ C$				6	
			$T_A = 25^\circ C$			5	7	
			$T_A = 85^\circ C$				8	
			$T_A = 125^\circ C$				9	
		$V_{is} = 0$ to 15V $V_{DD} = 15V$	$T_A = -55^\circ C$				7	
			$T_A = -40^\circ C$				7.5	
			$T_A = 25^\circ C$			5.5	8	
			$T_A = 85^\circ C$				9	
			$T_A = 125^\circ C$				10	
		$V_{is} = 0$ to 20V $V_{DD} = 20V$	$T_A = -55^\circ C$				8.5	
			$T_A = -40^\circ C$				8.5	
			$T_A = 25^\circ C$			6.5	9	
			$T_A = 85^\circ C$				10	
			$T_A = 125^\circ C$				11	
r_{ON}	ON Resistance r_{ON} Max	to $(V_{DD}+V_{SS})/2$, $V_C = V_{DD}$, $R_L = 10k\Omega$ returned $V_{is} = V_{SS}$ to V_{DD}	$V_{DD} = 5V$	$T_A = -55^\circ C$			800	Ω
				$T_A = -40^\circ C$			850	
				$T_A = 25^\circ C$		470	1050	
				$T_A = 85^\circ C$			1200	
				$T_A = 125^\circ C$			1300	
			$V_{DD} = 10V$	$T_A = -55^\circ C$			310	
				$T_A = -40^\circ C$			330	
				$T_A = 25^\circ C$		180	400	
				$T_A = 85^\circ C$			500	
				$T_A = 125^\circ C$			500	
			$V_{DD} = 15V$	$T_A = -55^\circ C$			200	
				$T_A = -40^\circ C$			210	
				$T_A = 25^\circ C$		125	240	
				$T_A = 85^\circ C$			300	
				$T_A = 125^\circ C$			320	

5.5 Electrical Characteristics (continued)

Over operating free-air temperature range, $V_{SUPPLY} = \pm 5V$, and $R_L = 100 \Omega$, (unless otherwise noted)⁽¹⁾

PARAMETER		TEST CONDITIONS			MIN	TYP	MAX	UNIT
V_{ILC}	Control input, low voltage (max)	$ I_{is} < 10 \mu A$, $V_{is} = V_{SS}$, $V_{OS} = V_{DD}$, and $V_{is} = V_{DD}$, $V_{OS} = V_{SS}$	$V_{DD} = 5V$	$T_A = -55^\circ C$			1	V
				$T_A = -40^\circ C$			1	
				$T_A = 25^\circ C$			1	
				$T_A = 85^\circ C$			1	
				$T_A = 125^\circ C$			1	
			$V_{DD} = 10V$	$T_A = -55^\circ C$			1	
				$T_A = -40^\circ C$			1	
				$T_A = 25^\circ C$			1	
				$T_A = 85^\circ C$			1	
				$T_A = 125^\circ C$			1	
			$V_{DD} = 15V$	$T_A = -55^\circ C$			1	
				$T_A = -40^\circ C$			1	
$T_A = 25^\circ C$				1				
$T_A = 85^\circ C$				1				
$T_A = 125^\circ C$				1				
I_{IN}	Input current (max)	$V_{is} \leq V_{DD}$, $V_{DD} - V_{SS} = 18V$, $V_{CC} \leq V_{DD} - V_{SS}$, $V_{DD} = 18V$	$T_A = -55^\circ C$		-0.8		0.8	μA
			$T_A = -40^\circ C$		-0.8		0.8	
	$T_A = 25^\circ C$			-0.7	± 0.2	0.7		
	$T_A = 85^\circ C$			-0.6		0.6		
	$T_A = 125^\circ C$			-0.55		0.55		

(1) Peak-to-Peak voltage symmetrical about $(V_{DD} - V_{EE}) / 2$.

5.6 Switching Characteristics

$T_A = 25^\circ C$

PARAMETER	FROM	TO	TEST CONDITIONS	V_{CC}	MIN	TYP	MAX	UNIT
t_{pd}	Signal input	Signal output	$V_{IN} = V_{DD}$, $t_r, t_f = 20ns$, $C_L = 50pF$, $R_L = 1k\Omega$	5V		20	40	ns
				10V		10	20	
				15V		7	15	
t_{ph}	Signal input	Signal output	$V_{IN} = V_{DD}$, $t_r, t_f = 20ns$, $C_L = 50pF$, $R_L = 1k\Omega$	5V		35	70	ns
				10V		20	40	
				15V		15	30	
t_{phi}	Signal input	Signal output	$V_{IN} = V_{DD}$, $t_r, t_f = 20ns$, $C_L = 50pF$, $R_L = 1k\Omega$	5V		35	70	ns
				10V		20	40	
				15V		15	30	

6 Parameter Measurement Information

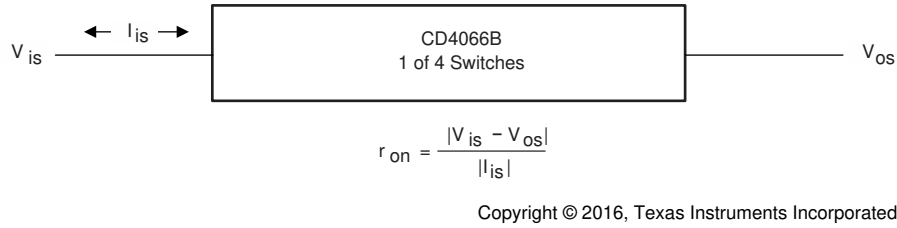

Figure 6-1. Determination of r_{on} as a Test Condition for Control-Input High-Voltage (V_{IHC}) Specification

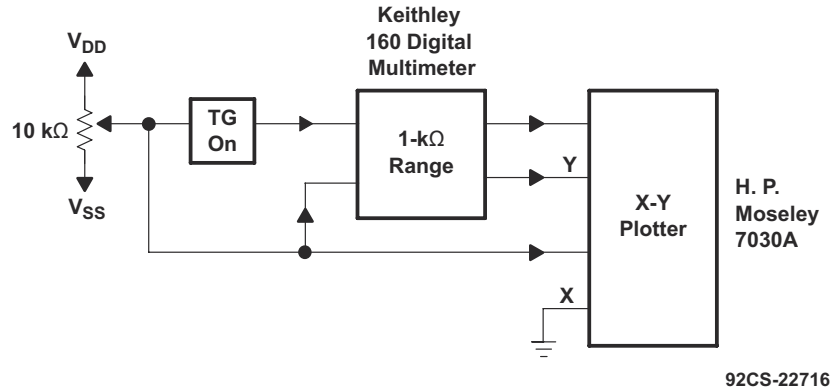
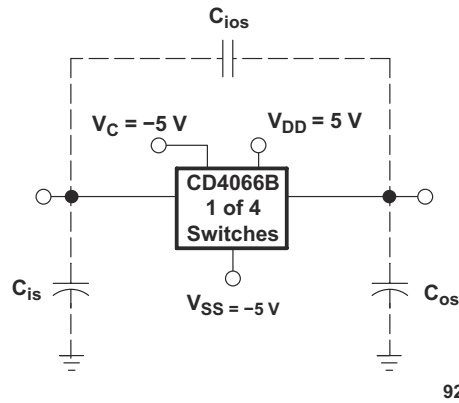
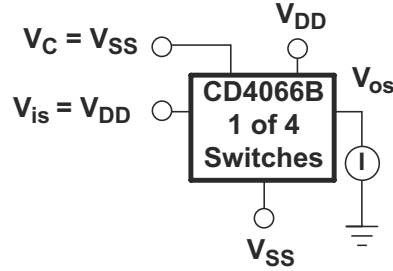

Figure 6-2. Channel On-State Resistance Measurement Circuit



Measured on Boonton capacitance bridge, model 75a (1 MHz);
test-fixture capacitance nulled out.

Figure 6-3. Typical On Characteristics for One of Four Channels



92CS-30922

All unused terminals are connected to V_{SS} .

Figure 6-4. Off-Switch Input or Output Leakage

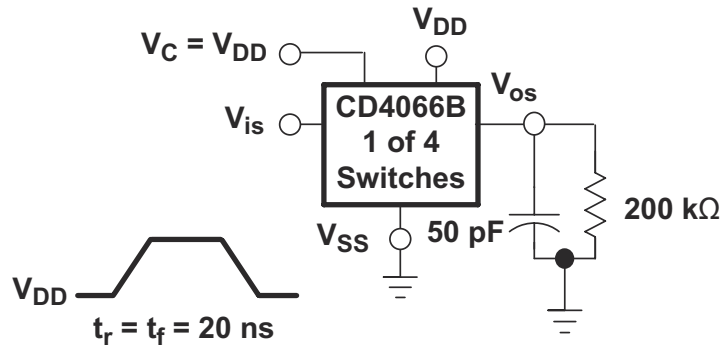

92CS-30923

All unused terminals are connected to V_{SS} .

Figure 6-5. Propagation Delay Time Signal Input (V_{is}) to Signal Output (V_{os})

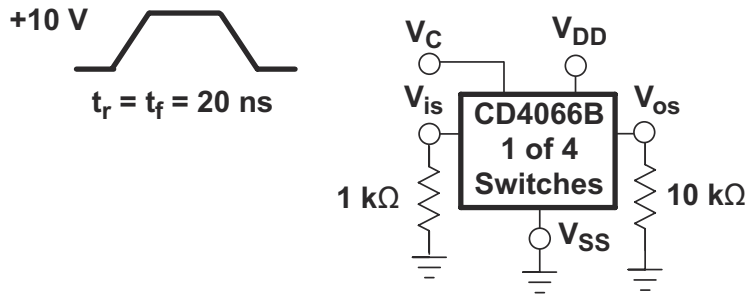

92CS-30924

All unused terminals are connected to V_{SS} .

Figure 6-6. Crosstalk-Control Input to Signal Output

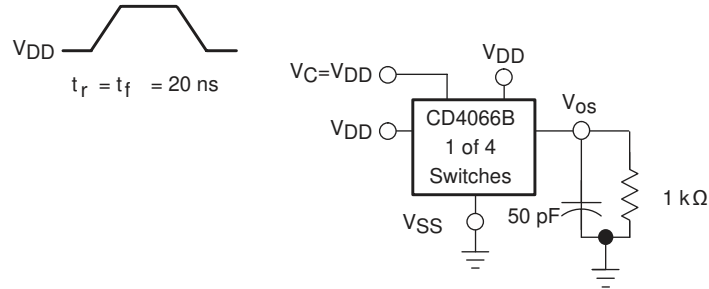

Copyright © 2016, Texas Instruments Incorporated

All unused pins are connected to V_{SS} .

Delay is measured at V_{OS} level of +10% from ground (turn-on) or on-state output level (turn-off).

Figure 6-7. Propagation Delay, t_{PLH} , t_{PHL} Control-Signal Output

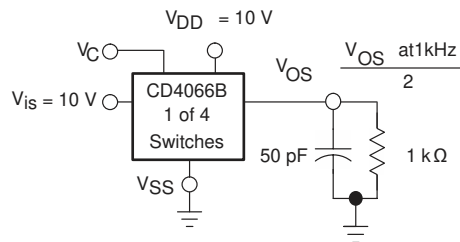
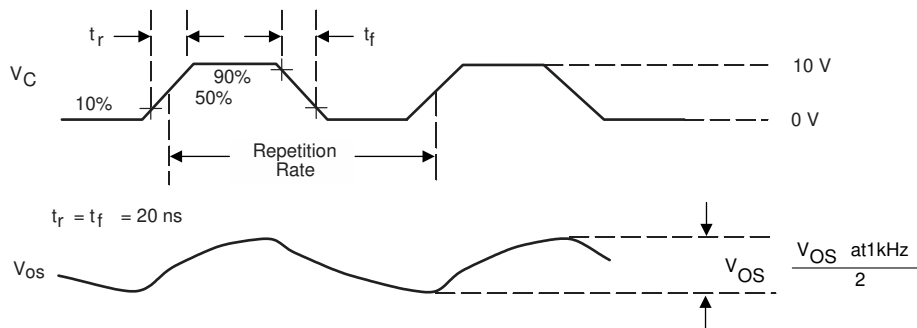

Copyright © 2016, Texas Instruments Incorporated

All unused pins are connected to V_{SS} .

Figure 6-8. Maximum Allowable Control-Input Repetition Rate

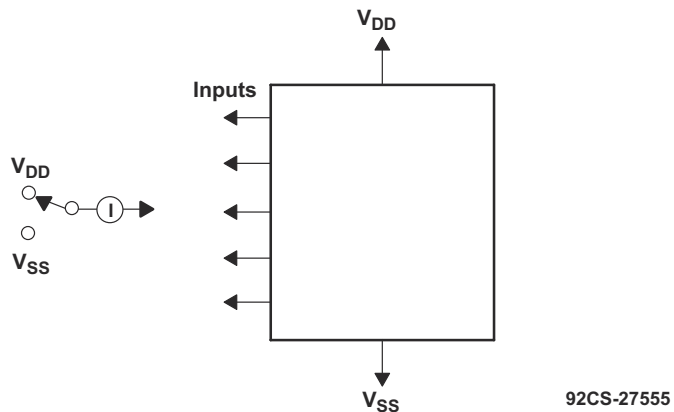

Measure inputs sequentially to both V_{DD} and V_{SS} . Connect all unused inputs to either V_{DD} or V_{SS} . Measure control inputs only.

Figure 6-9. Input Leakage-Current Test Circuit

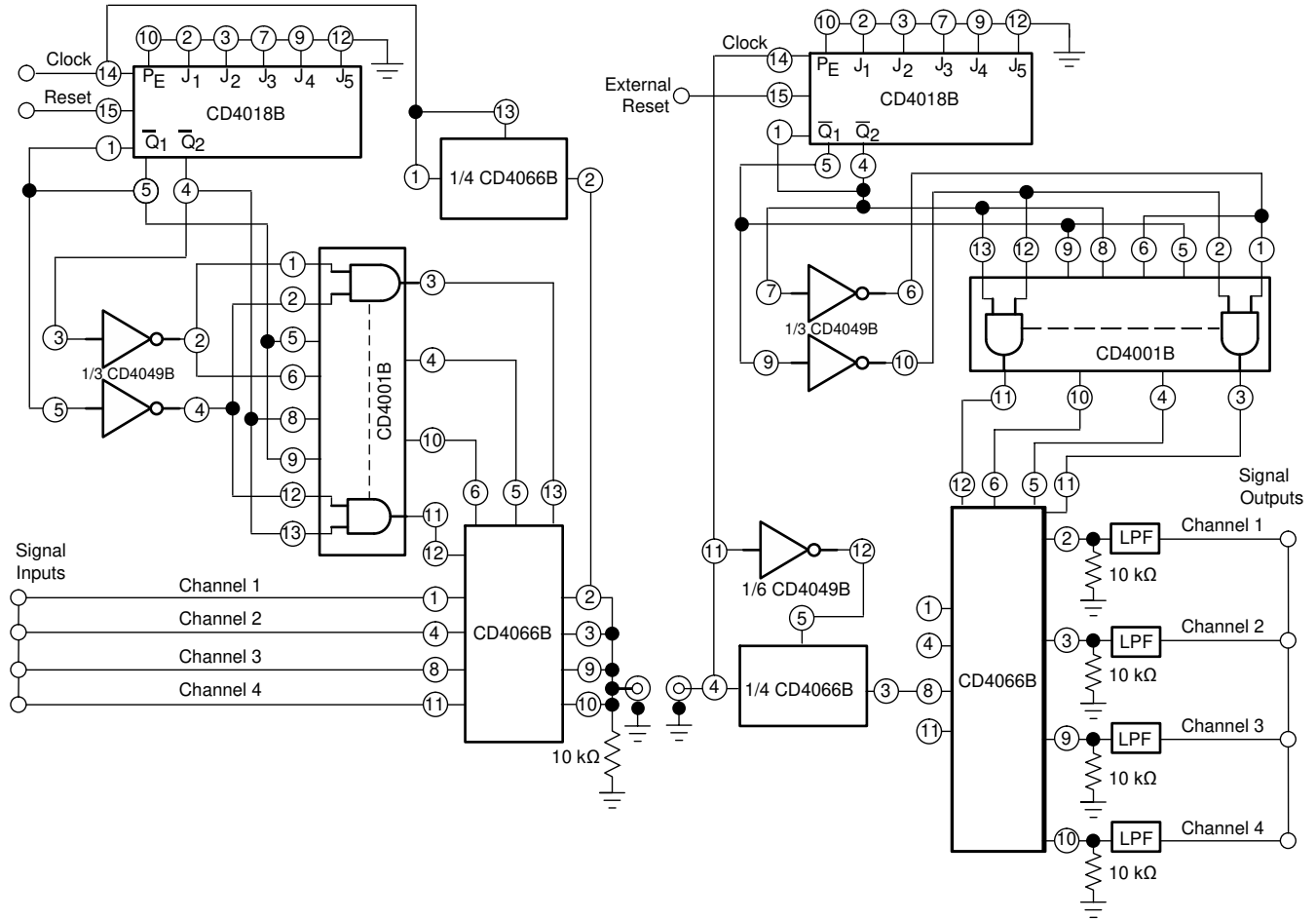

Copyright © 2016, Texas Instruments Incorporated

Figure 6-10. Four-Channel PAM Multiplex System Diagram

7 Detailed Description

7.1 Overview

CD4066B has four independent digitally controlled analog switches with a bias voltage of V_{SS} to allow for different voltage levels to be used for low output. Both the p and n devices in a given switch are biased on or off simultaneously by the control signal. As shown in Figure 7-1, the well of the n-channel device on each switch is tied to either the input (when the switch is on) or to V_{SS} (when the switch is off). Thus, when the control of the device is low, the output of the switch goes to V_{SS} and when the control is high the output of the device goes to V_{DD} .

7.2 Functional Block Diagram

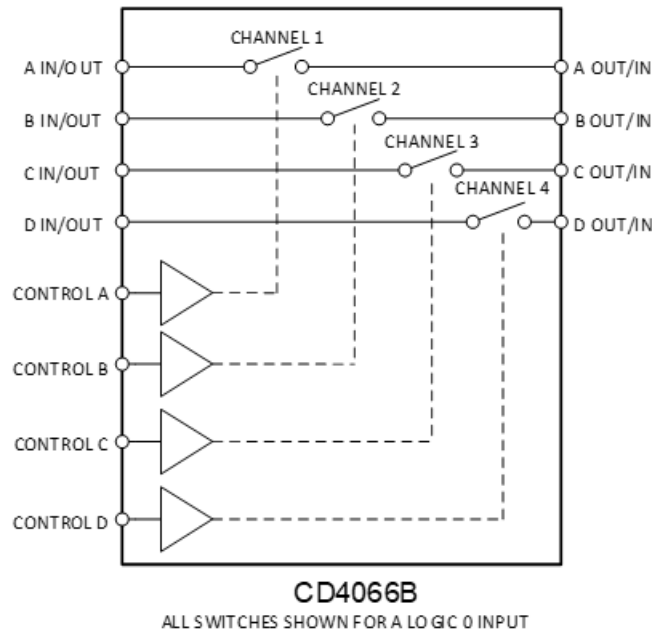

- A. All control inputs are protected by the CMOS protection network.
- B. All p substrates are connected to V_{DD} .
- C. Normal operation control-line biasing: switch on (logic 1), $V_C = V_{DD}$; switch off (logic 0), $V_C = V_{SS}$.
- D. Signal-level range: $V_{SS} \leq V_{is} \leq V_{DD}$.

Figure 7-1. Schematic Diagram of One-of-Four Identical Switches and Associated Control Circuitry

7.3 Feature Description

Each switch has different control pins, which allows for more options for the outputs. Bias Voltage allows the device to output a voltage other than 0V when the device control is low. The CD4066B has a large absolute maximum voltage for V_{DD} of 20V.

7.4 Device Functional Modes

Table 7-1 lists the functions of this device.

Table 7-1. Function Table

INPUTS		OUTPUT
SIG IN/OUT	CONTROL	SIG OUT/IN
H	H	H
L	H	L
X	L	Hi-Z

8 Application and Implementation

Note

Information in the following applications sections is not part of the TI component specification, and TI does not warrant its accuracy or completeness. TI's customers are responsible for determining suitability of components for their purposes, as well as validating and testing their design implementation to confirm system functionality.

8.1 Application Information

In applications that employ separate power sources to drive V_{DD} and the signal inputs, the V_{DD} current capability should exceed V_{DD}/R_L (R_L = effective external load of the four CD4066B device bilateral switches). This provision avoids any permanent current flow or clamp action on the V_{DD} supply when power is applied or removed from the CD4066B device.

In certain applications, the external load-resistor current can include both V_{DD} and signal-line components. To avoid drawing V_{DD} current when switch current flows into pins 1, 4, 8, or 11, the voltage drop across the bidirectional switch must not exceed 0.8V (calculated from r_{on} values shown).

No V_{DD} current flows through R_L if the switch current flows into pins 2, 3, 9, or 10.

8.2 Typical Application

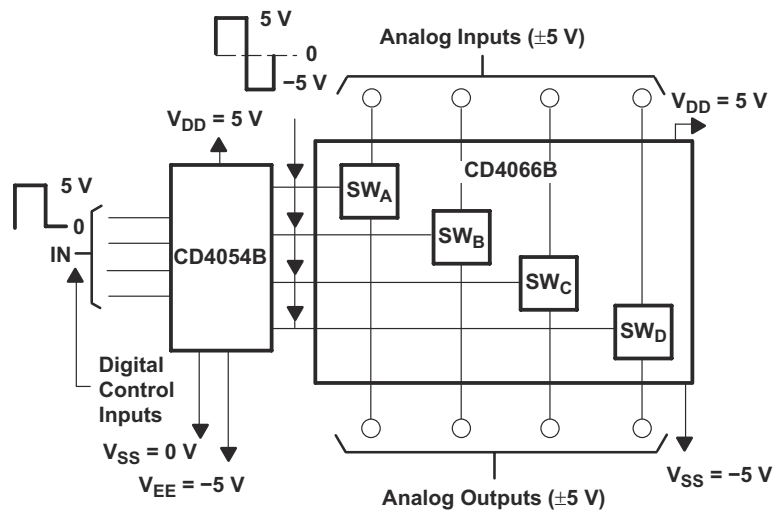

92CS-30927

Figure 8-1. Bidirectional Signal Transmission Through Digital Control Logic

8.2.1 Design Requirements

This device uses CMOS technology and has balanced output drive. Avoid bus contention because it can drive currents in excess of maximum limits. The high drive also creates fast edges into light loads, so consider routing and load conditions to prevent ringing.

8.2.2 Detailed Design Procedure

- Recommended input conditions:
 - For rise time and fall time specifications, see $\Delta t/\Delta v$ in [Recommended Operating Conditions](#).
 - For specified high and low levels, see V_{IH} and V_{IL} in [Recommended Operating Conditions](#).
- Recommended output conditions:
 - Load currents should not exceed $\pm 10mA$.

8.2.3 Application Curve

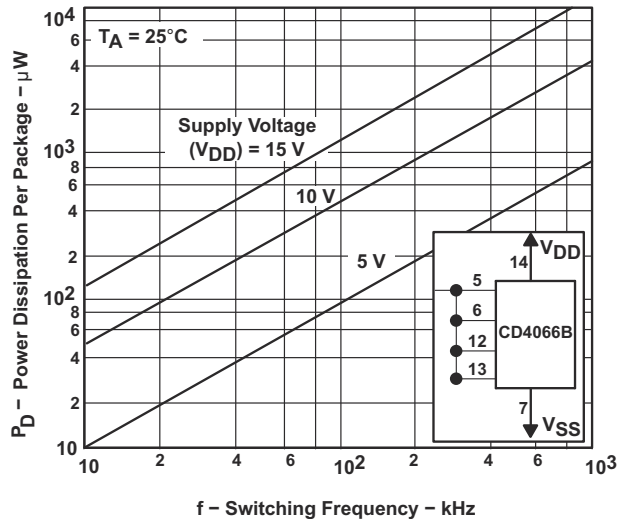

Figure 8-2. Power Dissipation vs. Switching Frequency

8.3 Power Supply Recommendations

The power supply can be any voltage between the MIN and MAX supply voltage rating located in [Recommended Operating Conditions](#).

Each VCC pin should have a good bypass capacitor to prevent power disturbance. For devices with a single supply, 0.1μF is recommended; if there are multiple VCC pins, then 0.01μF or 0.022μF is recommended for each power pin. It is acceptable to parallel multiple bypass capacitors to reject different frequencies of noise. A 0.1μF and a 1μF are commonly used in parallel. The bypass capacitor should be installed as close to the power pin as possible for best results.

8.4 Layout

8.4.1 Layout Guidelines

When using multiple bit logic devices inputs must never float.

In many cases, functions or parts of functions of digital logic devices are unused, for example, when only two inputs of a triple-input *and* gate are used or only 3 of the 4 buffer gates are used. Such input pins must not be left unconnected because the undefined voltages at the outside connections result in undefined operational states. All unused inputs of digital logic devices must be connected to a high or low bias to prevent them from floating. The logic level that should be applied to any particular unused input depends on the function of the device. Generally they are tied to GND or VCC, whichever makes more sense or is more convenient. It is generally acceptable to float outputs, unless the part is a transceiver. If the transceiver has an output enable pin, it disables the output section of the part when asserted. This does not disable the input section of the I/Os, so they cannot float when disabled.

8.4.2 Layout Example

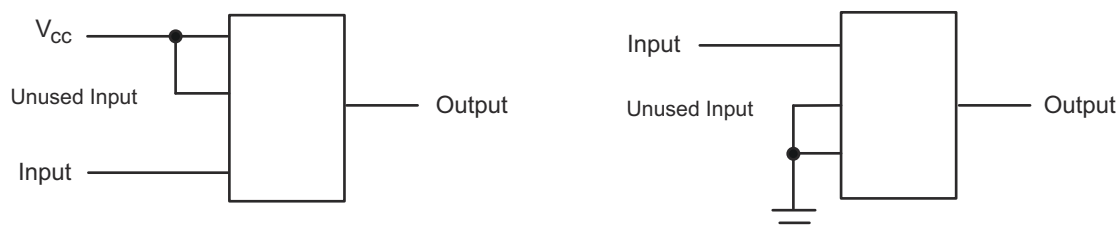

Figure 8-3. Diagram for Unused Inputs

9 Device and Documentation Support

9.1 Receiving Notification of Documentation Updates

To receive notification of documentation updates, navigate to the device product folder on ti.com. Click on *Notifications* to register and receive a weekly digest of any product information that has changed. For change details, review the revision history included in any revised document.

9.2 Support Resources

[TI E2E™ support forums](#) are an engineer's go-to source for fast, verified answers and design help — straight from the experts. Search existing answers or ask your own question to get the quick design help you need.

Linked content is provided "AS IS" by the respective contributors. They do not constitute TI specifications and do not necessarily reflect TI's views; see TI's [Terms of Use](#).

9.3 Trademarks

TI E2E™ is a trademark of Texas Instruments.
All trademarks are the property of their respective owners.

9.4 Electrostatic Discharge Caution



This integrated circuit can be damaged by ESD. Texas Instruments recommends that all integrated circuits be handled with appropriate precautions. Failure to observe proper handling and installation procedures can cause damage.

ESD damage can range from subtle performance degradation to complete device failure. Precision integrated circuits may be more susceptible to damage because very small parametric changes could cause the device not to meet its published specifications.

9.5 Glossary

[TI Glossary](#) This glossary lists and explains terms, acronyms, and definitions.

10 Revision History

NOTE: Page numbers for previous revisions may differ from page numbers in the current version.

Changes from Revision H (January 2020) to Revision I (May 2024)	Page
• Changed <i>Package Information</i> table to include package leads.....	1
• Changed the numbering format for tables, figures, and cross-references throughout the document.....	1
• Deleted the <i>J (CDIP, 14)</i> package from the data sheet.....	1
• Changed max and typ IDD for lower supply voltages.....	4
• Changed VIL from 2V to 1V across supply.....	4

Changes from Revision G (June 2017) to Revision H (January 2020)	Page
• Added Junction Temperature details to the <i>Absolute Maximum Ratings</i> table.....	3

11 Mechanical, Packaging, and Orderable Information

The following pages include mechanical, packaging, and orderable information. This information is the most current data available for the designated devices. This data is subject to change without notice and revision of this document. For browser-based versions of this data sheet, refer to the left-hand navigation.

PACKAGING INFORMATION

Orderable Device	Status (1)	Package Type	Package Drawing	Pins	Package Qty	Eco Plan (2)	Lead finish/ Ball material (6)	MSL Peak Temp (3)	Op Temp (°C)	Device Marking (4/5)	Samples
CD4066BE	ACTIVE	PDIP	N	14	25	RoHS & Green	NIPDAU	N / A for Pkg Type	-55 to 125	CD4066BE	Samples
CD4066BEE4	ACTIVE	PDIP	N	14	25	RoHS & Green	NIPDAU	N / A for Pkg Type	-55 to 125	CD4066BE	Samples
CD4066BF	ACTIVE	CDIP	J	14	25	Non-RoHS & Green	SNPB	N / A for Pkg Type	-55 to 125	CD4066BF	Samples
CD4066BF3A	ACTIVE	CDIP	J	14	25	Non-RoHS & Green	SNPB	N / A for Pkg Type	-55 to 125	CD4066BF3A	Samples
CD4066BM96	ACTIVE	SOIC	D	14	2500	RoHS & Green	NIPDAU SN	Level-1-260C-UNLIM	-55 to 125	CD4066BM	Samples
CD4066BNSR	ACTIVE	SO	NS	14	2000	RoHS & Green	NIPDAU	Level-1-260C-UNLIM	-55 to 125	CD4066B	Samples
CD4066BPWR	ACTIVE	TSSOP	PW	14	2000	RoHS & Green	NIPDAU SN	Level-1-260C-UNLIM	-55 to 125	CM066B	Samples
JM38510/05852BCA	ACTIVE	CDIP	J	14	25	Non-RoHS & Green	SNPB	N / A for Pkg Type	-55 to 125	JM38510/ 05852BCA	Samples
M38510/05852BCA	ACTIVE	CDIP	J	14	25	Non-RoHS & Green	SNPB	N / A for Pkg Type	-55 to 125	JM38510/ 05852BCA	Samples

(1) The marketing status values are defined as follows:

ACTIVE: Product device recommended for new designs.

LIFEBUY: TI has announced that the device will be discontinued, and a lifetime-buy period is in effect.

NRND: Not recommended for new designs. Device is in production to support existing customers, but TI does not recommend using this part in a new design.

PREVIEW: Device has been announced but is not in production. Samples may or may not be available.

OBSELETE: TI has discontinued the production of the device.

(2) **RoHS:** TI defines "RoHS" to mean semiconductor products that are compliant with the current EU RoHS requirements for all 10 RoHS substances, including the requirement that RoHS substance do not exceed 0.1% by weight in homogeneous materials. Where designed to be soldered at high temperatures, "RoHS" products are suitable for use in specified lead-free processes. TI may reference these types of products as "Pb-Free".

RoHS Exempt: TI defines "RoHS Exempt" to mean products that contain lead but are compliant with EU RoHS pursuant to a specific EU RoHS exemption.

Green: TI defines "Green" to mean the content of Chlorine (Cl) and Bromine (Br) based flame retardants meet JS709B low halogen requirements of <=1000ppm threshold. Antimony trioxide based flame retardants must also meet the <=1000ppm threshold requirement.

(3) MSL, Peak Temp. - The Moisture Sensitivity Level rating according to the JEDEC industry standard classifications, and peak solder temperature.

(4) There may be additional marking, which relates to the logo, the lot trace code information, or the environmental category on the device.

⁽⁵⁾ Multiple Device Markings will be inside parentheses. Only one Device Marking contained in parentheses and separated by a "~" will appear on a device. If a line is indented then it is a continuation of the previous line and the two combined represent the entire Device Marking for that device.

⁽⁶⁾ Lead finish/Ball material - Orderable Devices may have multiple material finish options. Finish options are separated by a vertical ruled line. Lead finish/Ball material values may wrap to two lines if the finish value exceeds the maximum column width.

Important Information and Disclaimer:The information provided on this page represents TI's knowledge and belief as of the date that it is provided. TI bases its knowledge and belief on information provided by third parties, and makes no representation or warranty as to the accuracy of such information. Efforts are underway to better integrate information from third parties. TI has taken and continues to take reasonable steps to provide representative and accurate information but may not have conducted destructive testing or chemical analysis on incoming materials and chemicals. TI and TI suppliers consider certain information to be proprietary, and thus CAS numbers and other limited information may not be available for release.

In no event shall TI's liability arising out of such information exceed the total purchase price of the TI part(s) at issue in this document sold by TI to Customer on an annual basis.

OTHER QUALIFIED VERSIONS OF CD4066B, CD4066B-MIL :

- Catalog : [CD4066B](#)
- Automotive : [CD4066B-Q1](#), [CD4066B-Q1](#)
- Military : [CD4066B-MIL](#)

NOTE: Qualified Version Definitions:

- Catalog - TI's standard catalog product
- Automotive - Q100 devices qualified for high-reliability automotive applications targeting zero defects
- Military - QML certified for Military and Defense Applications

TAPE AND REEL INFORMATION

QUADRANT ASSIGNMENTS FOR PIN 1 ORIENTATION IN TAPE

*All dimensions are nominal

Device	Package Type	Package Drawing	Pins	SPQ	Reel Diameter (mm)	Reel Width W1 (mm)	A0 (mm)	B0 (mm)	K0 (mm)	P1 (mm)	W (mm)	Pin1 Quadrant
CD4066BM96	SOIC	D	14	2500	330.0	16.4	6.5	9.0	2.1	8.0	16.0	Q1
CD4066BM96G4	SOIC	D	14	2500	330.0	16.4	6.5	9.0	2.1	8.0	16.0	Q1
CD4066BM96G4	SOIC	D	14	2500	330.0	16.4	6.5	9.0	2.1	8.0	16.0	Q1
CD4066BMT	SOIC	D	14	250	330.0	16.4	6.5	9.0	2.1	8.0	16.0	Q1
CD4066BNSR	SO	NS	14	2000	330.0	16.4	8.2	10.5	2.5	12.0	16.0	Q1
CD4066BPWR	TSSOP	PW	14	2000	330.0	12.4	6.9	5.6	1.6	8.0	12.0	Q1
CD4066BPWRG4	TSSOP	PW	14	2000	330.0	12.4	6.9	5.6	1.6	8.0	12.0	Q1

TAPE AND REEL BOX DIMENSIONS

*All dimensions are nominal

Device	Package Type	Package Drawing	Pins	SPQ	Length (mm)	Width (mm)	Height (mm)
CD4066BM96	SOIC	D	14	2500	340.5	336.1	32.0
CD4066BM96G4	SOIC	D	14	2500	356.0	356.0	35.0
CD4066BM96G4	SOIC	D	14	2500	340.5	336.1	32.0
CD4066BMT	SOIC	D	14	250	210.0	185.0	35.0
CD4066BNSR	SO	NS	14	2000	356.0	356.0	35.0
CD4066BPWR	TSSOP	PW	14	2000	367.0	367.0	35.0
CD4066BPWRG4	TSSOP	PW	14	2000	356.0	356.0	35.0

TUBE

*All dimensions are nominal

Device	Package Name	Package Type	Pins	SPQ	L (mm)	W (mm)	T (μm)	B (mm)
CD4066BE	N	PDIP	14	25	506	13.97	11230	4.32
CD4066BE	N	PDIP	14	25	506	13.97	11230	4.32
CD4066BE	N	PDIP	14	25	506.1	9	600	5.4
CD4066BEE4	N	PDIP	14	25	506	13.97	11230	4.32
CD4066BEE4	N	PDIP	14	25	506	13.97	11230	4.32
CD4066BEE4	N	PDIP	14	25	506.1	9	600	5.4
CD4066BM	D	SOIC	14	50	506.6	8	3940	4.32
CD4066BNS	NS	SOP	14	50	530	10.5	4000	4.1
CD4066BPW	PW	TSSOP	14	90	530	10.2	3600	3.5
CD4066BPWG4	PW	TSSOP	14	90	530	10.2	3600	3.5

J 14

GENERIC PACKAGE VIEW
CDIP - 5.08 mm max height
CERAMIC DUAL IN LINE PACKAGE

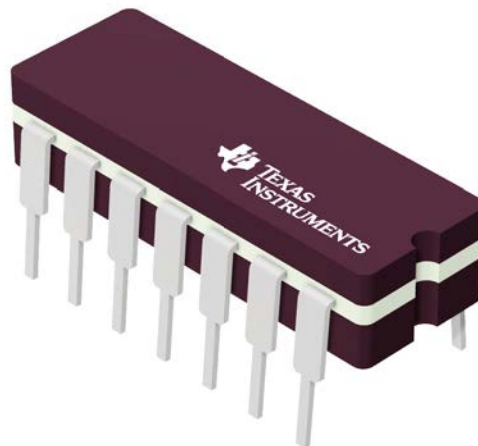

Images above are just a representation of the package family, actual package may vary.
Refer to the product data sheet for package details.

4040083-5/G

J0014A



PACKAGE OUTLINE

CDIP - 5.08 mm max height

CERAMIC DUAL IN LINE PACKAGE



4214771/A 05/2017

NOTES:

1. All controlling linear dimensions are in inches. Dimensions in brackets are in millimeters. Any dimension in brackets or parenthesis are for reference only. Dimensioning and tolerancing per ASME Y14.5M.
2. This drawing is subject to change without notice.
3. This package is hermetically sealed with a ceramic lid using glass frit.
4. Index point is provided on cap for terminal identification only and on press ceramic glass frit seal only.
5. Falls within MIL-STD-1835 and GDIP1-T14.

EXAMPLE BOARD LAYOUT

J0014A

CDIP - 5.08 mm max height

CERAMIC DUAL IN LINE PACKAGE

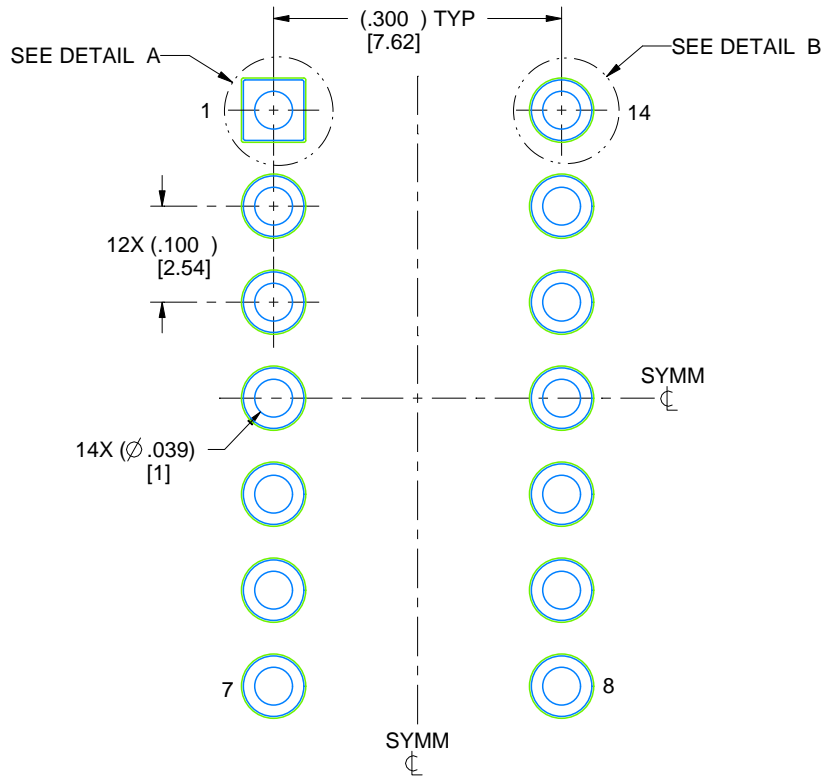

LAND PATTERN EXAMPLE
NON-SOLDER MASK DEFINED
SCALE: 5X



4214771/A 05/2017

D (R-PDSO-G14)

PLASTIC SMALL OUTLINE



4040047-5/M 06/11

- NOTES:
- A. All linear dimensions are in inches (millimeters).
 - B. This drawing is subject to change without notice.
 - $\triangle C$ Body length does not include mold flash, protrusions, or gate burrs. Mold flash, protrusions, or gate burrs shall not exceed 0.006 (0,15) each side.
 - $\triangle D$ Body width does not include interlead flash. Interlead flash shall not exceed 0.017 (0,43) each side.
 - E. Reference JEDEC MS-012 variation AB.

PW (R-PDSO-G14)

PLASTIC SMALL OUTLINE

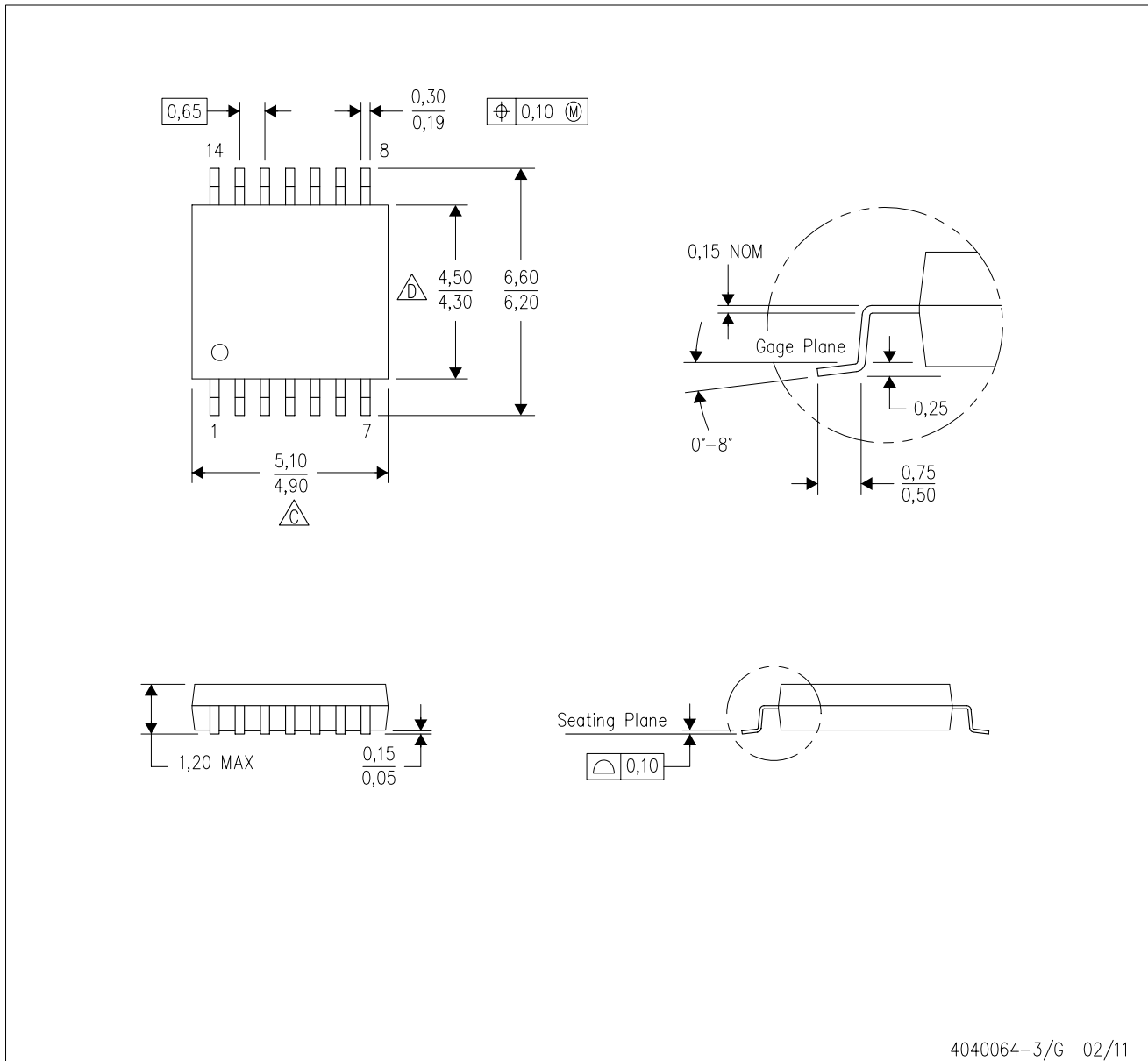

4040064-3/G 02/11

- NOTES:
- A. All linear dimensions are in millimeters. Dimensioning and tolerancing per ASME Y14.5M-1994.
 - B. This drawing is subject to change without notice.
 - C. Body length does not include mold flash, protrusions, or gate burrs. Mold flash, protrusions, or gate burrs shall not exceed 0,15 each side.
 - D. Body width does not include interlead flash. Interlead flash shall not exceed 0,25 each side.
 - E. Falls within JEDEC MO-153

PW (R-PDSO-G14)

PLASTIC SMALL OUTLINE

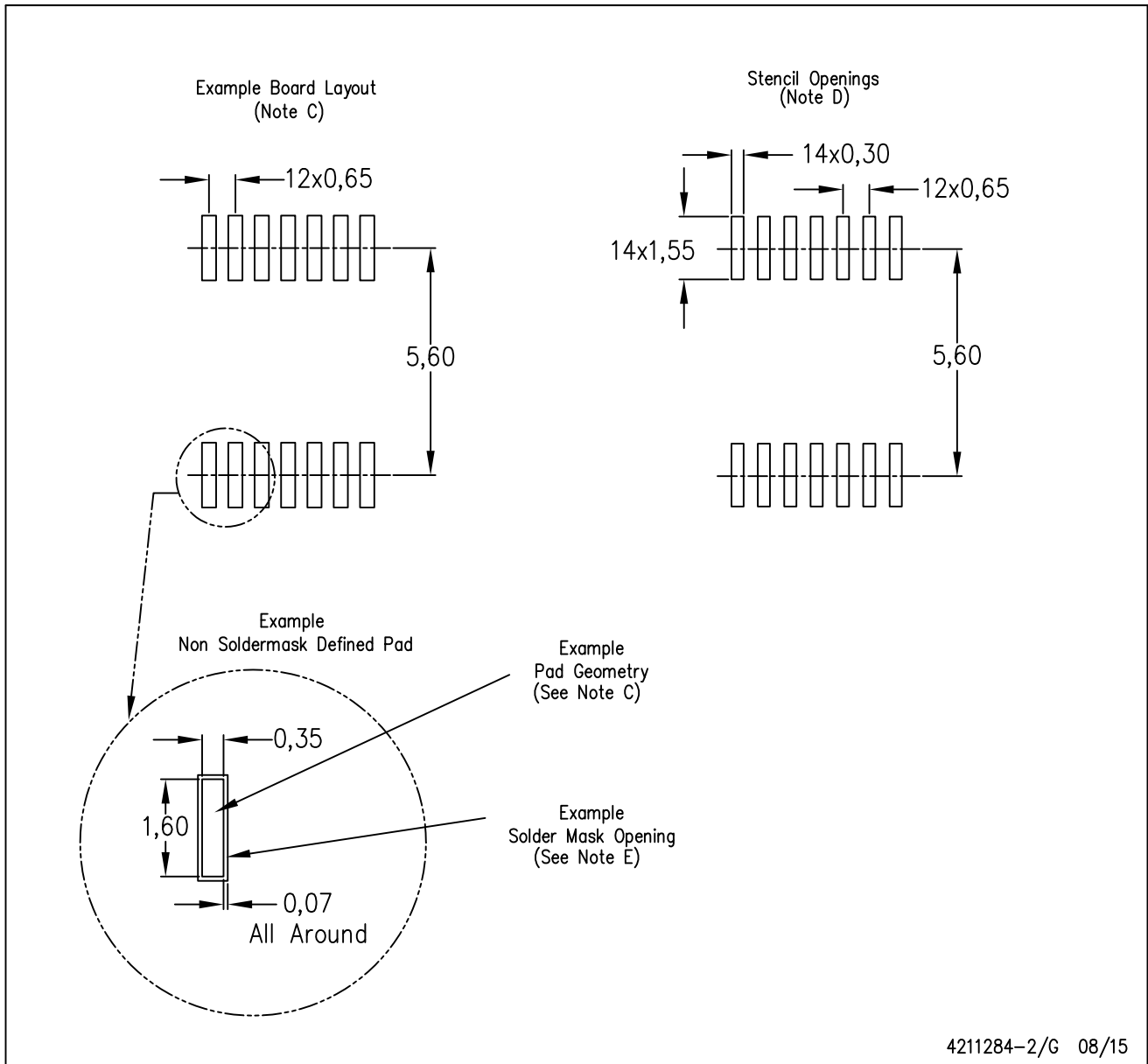

4211284-2/G 08/15

- NOTES:
- A. All linear dimensions are in millimeters.
 - B. This drawing is subject to change without notice.
 - C. Publication IPC-7351 is recommended for alternate designs.
 - D. Laser cutting apertures with trapezoidal walls and also rounding corners will offer better paste release. Customers should contact their board assembly site for stencil design recommendations. Refer to IPC-7525 for other stencil recommendations.
 - E. Customers should contact their board fabrication site for solder mask tolerances between and around signal pads.

N (R-PDIP-T**)

PLASTIC DUAL-IN-LINE PACKAGE

16 PINS SHOWN



- NOTES:
- A. All linear dimensions are in inches (millimeters).
 - B. This drawing is subject to change without notice.
 - $\triangle C$ Falls within JEDEC MS-001, except 18 and 20 pin minimum body length (Dim A).
 - $\triangle D$ The 20 pin end lead shoulder width is a vendor option, either half or full width.

4040049/E 12/2002

MECHANICAL DATA

NS (R-PDSO-G**)

PLASTIC SMALL-OUTLINE PACKAGE

14-PINS SHOWN



- NOTES:
- A. All linear dimensions are in millimeters.
 - B. This drawing is subject to change without notice.
 - C. Body dimensions do not include mold flash or protrusion, not to exceed 0,15.

IMPORTANT NOTICE AND DISCLAIMER

TI PROVIDES TECHNICAL AND RELIABILITY DATA (INCLUDING DATA SHEETS), DESIGN RESOURCES (INCLUDING REFERENCE DESIGNS), APPLICATION OR OTHER DESIGN ADVICE, WEB TOOLS, SAFETY INFORMATION, AND OTHER RESOURCES "AS IS" AND WITH ALL FAULTS, AND DISCLAIMS ALL WARRANTIES, EXPRESS AND IMPLIED, INCLUDING WITHOUT LIMITATION ANY IMPLIED WARRANTIES OF MERCHANTABILITY, FITNESS FOR A PARTICULAR PURPOSE OR NON-INFRINGEMENT OF THIRD PARTY INTELLECTUAL PROPERTY RIGHTS.

These resources are intended for skilled developers designing with TI products. You are solely responsible for (1) selecting the appropriate TI products for your application, (2) designing, validating and testing your application, and (3) ensuring your application meets applicable standards, and any other safety, security, regulatory or other requirements.

These resources are subject to change without notice. TI grants you permission to use these resources only for development of an application that uses the TI products described in the resource. Other reproduction and display of these resources is prohibited. No license is granted to any other TI intellectual property right or to any third party intellectual property right. TI disclaims responsibility for, and you will fully indemnify TI and its representatives against, any claims, damages, costs, losses, and liabilities arising out of your use of these resources.

TI's products are provided subject to [TI's Terms of Sale](#) or other applicable terms available either on [ti.com](https://www.ti.com) or provided in conjunction with such TI products. TI's provision of these resources does not expand or otherwise alter TI's applicable warranties or warranty disclaimers for TI products.

TI objects to and rejects any additional or different terms you may have proposed.

Mailing Address: Texas Instruments, Post Office Box 655303, Dallas, Texas 75265
Copyright © 2024, Texas Instruments Incorporated

Looking for pricing, stock, or lifecycle information?

Click below to explore more details on WIN SOURCE:

 [View CD4066BF](#) on WIN SOURCE

 [Texas Instruments](#) Information

Optimize Your Supply Chain with WIN SOURCE Solutions

-  Global Sourcing Solution
-  Obsolete Management
-  Cost Control Management
-  Shortage Management
-  Alternative Solution
-  Excess Inventory Management