



THE DATASHEET OF L6701TR



3 Phase Controller for VR10, VR9 and K8 CPUs

Features

- MULTI-DAC: VR9, VR10 AND K8 DAC SELECTABLE THROUGH SINGLE PIN
- 0.7% OUTPUT VOLTAGE ACCURACY
- ADJUSTABLE REFERENCE OFFSET
- HIGH CURRENT INTEGRATED DRIVERS
- DYNAMIC VID MANAGEMENT
- ACCURATE FULLY-DIFFERENTIAL LOAD-LINE CURRENT-SENSE ACROSS MAIN INDUCTORS MAKES BOM INDEPENDENT ON THE LAYOUT
- PRECISE CURRENT-SHARING AND OCP ACROSS LS MOSFETS
- CONSTANT OVER-CURRENT PROTECTION
- FEEDBACK DISCONNECTION PROTECTION
- PRELIMINARY OV PROTECTION
- OSCILLATOR INTERNALLY FIXED AT 100kHz (300kHz RIPPLE) EXT ADJUSTABLE
- SS_END / PGOOD SIGNAL
- INTEGRATED REMOTE-SENSE BUFFER
- PWSSO36 PACKAGE WITH EXPOSED PAD

Applications

- HIGH CURRENT VRM / VRD FOR DESKTOP / SERVER / WORKSTATION CPUs
- HIGH DENSITY DC / DC CONVERTERS

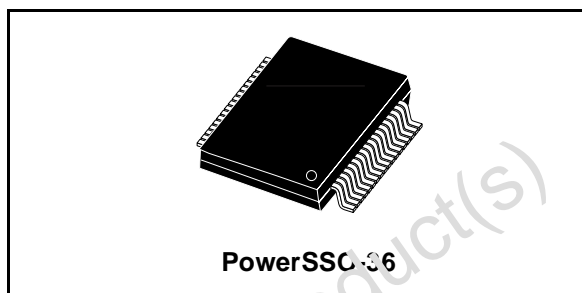

Description

L6701 is an extremely simple, low cost solution to implement a three phase step-down controller with integrated high-current drivers in a compact PowerSSO-36 package with exposed pad.

The device embeds three selectable DACs: with a single pin it is possible to program the device to work in compatibility with VR9, VR10 or K8 applications managing D-VID with $\pm 0.7\%$ output voltage accuracy over line and temperature variations. Additional programmable offset can be added to the reference voltage with a single external resistor.

Fast protection against load over current let the system works in Constant Current mode until UVP. Preliminary OVP allows full load protection in case of startup with failed HS. Furthermore, feedback disconnection prevents from damaging the load in case of misconnections in the system board.

Combined use of DCR and $R_{DS(on)}$ current sensing assures precision in voltage positioning and safe current sharing and OCP per each phase.

Order codes

Part number	Package	Packing
L6701	PowerSSO-36	Tube
L6701TR	PowerSSO-36	Tape & Reel

Contents

1	Device Description	4
2	Pins description and connection diagrams	5
	2.1 Pin description	5
3	Maximum Ratings	8
	3.1 Absolute maximum ratings	8
	3.2 Thermal data	8
4	Electrical specifications	9
	4.1 Electrical characteristics	9
5	Typical application circuit and block diagram	11
	5.1 Application circuit	11
	5.2 Block diagram	13
6	VID Tables	14
7	Configuring the Device: DAC Selection	17
	7.1 Single-Wire CPU Automatic Detection	17
8	Driver Section	18
	8.1 Power Dissipation	18
9	Current Sharing Loop and Current Reading	20
	9.1 Current Sharing Loop	20
	9.2 Current Reading for Current Sharing	20
10	Output Voltage Positioning	21
	10.1 Load-Line (Droop Function - Optional)	21
	10.2 Fully-Differential Load-Line (Droop Function - Optional)	22
	10.3 Offset (Optional)	24
	10.4 Remote Voltage Sense	24
	10.5 Maximum Duty Cycle limitation	25

11	Dynamic VID Transitions	26
12	Soft Start	28
12.1	Low-Side-Less Startup (LSLess)	28
13	Output voltage Monitor and Protections	29
13.1	Under Voltage	29
13.2	Preliminary Over Voltage	29
13.3	Over Voltage	30
13.4	Feedback Disconnection	30
13.5	PGOOD (Only for VR9 and K8 Modes)	31
13.6	Over Current Protection	31
14	Oscillator	34
15	System Control Loop Compensation	35
15.1	Compensation Network Guidelines	37
16	Layout Guidelines	38
16.1	Power Components and Connections	38
16.2	Small Signal Components and Connections	39
16.3	Embedding L6701-based VRs	40
17	Package Mechanical Data	41
18	Revision history	43

1 Device Description

L6701 is multi-phase PWM controller with embedded high-current drivers that provides complete control logic and protections for a high-performance step-down DC-DC voltage regulator, optimized for advanced microprocessor power supply. Multi-phase buck is the simplest and most cost-effective topology employable to satisfy the increasing current demand of newer microprocessors and the modern high-current DC/DC converters and POLs requirements. It allows distributing equally load and power between the phases using smaller, cheaper and most common external power MOSFETs and inductors. Moreover, thanks to the equal phase-shift between each phase, the input and output capacitor count results in being reduced. Phase-interleaving causes in fact input rms current and output ripple voltage reduction and shows an effective output switching frequency increase: the 100kHz free-running frequency per phase, externally adjustable through a resistor, results multiplied on the output by the number of phases so reaching 300kHz in free-running.

L6701 includes multiple DACs, selectable through an apposite pin, allowing compatibility with both Intel VR9, VR10 and AMD Hammer specifications, also performing DVVID transitions accordingly. In particular for Intel CPUs, it allows to automatically recognize the CPU with a single-wire connection, without any additional external component, by proper connecting the selector pin to the proper CPU pin.

Precise voltage positioning (LL) is possible thanks to an accurate fully-differential current-sense across the main inductors still using only two pins for current-reading (pat. pend.): this makes any BOM insensitive to the board layout saving time in the design stage.

The device internally balance the current driven by each phase by sensing the voltage drop across the LS MOSFET $R_{DS(on)}$. OC protection is effective with a threshold for each phase causing the device to work in constant-current mode.

The controller provides output voltage protections to avoid any load damage due to failed components and/or feedback misconnections. Over-Voltage protects the load from dangerous over stress latching immediately the device by turning-on the lower driver and driving high the FAULT pin. Furthermore, preliminary-OVP protection also allows the device to protect the load from dangerous OVP when V_{CC} is not above the UVLO threshold. Under-Voltage protection causes the device to stop switching when set while Over-Current protection, with a threshold for each phase, causes the device to enter in constant current mode until the latched UVP.

L6701 implements soft-start increasing the reference up to the final value in 2048 clock cycles in closed loop regulation. Low-Side-Less feature allows the device to perform soft-start over pre-biased output avoiding dangerous current return through the main inductors as well as negative spike at the load side.

The compact PowerSSO-36 package with exposed thermal pad allows dissipating the power to drive the external MOSFET through the system board.

2 Pins description and connection diagrams

Figure 1. Pins connection (Top view)

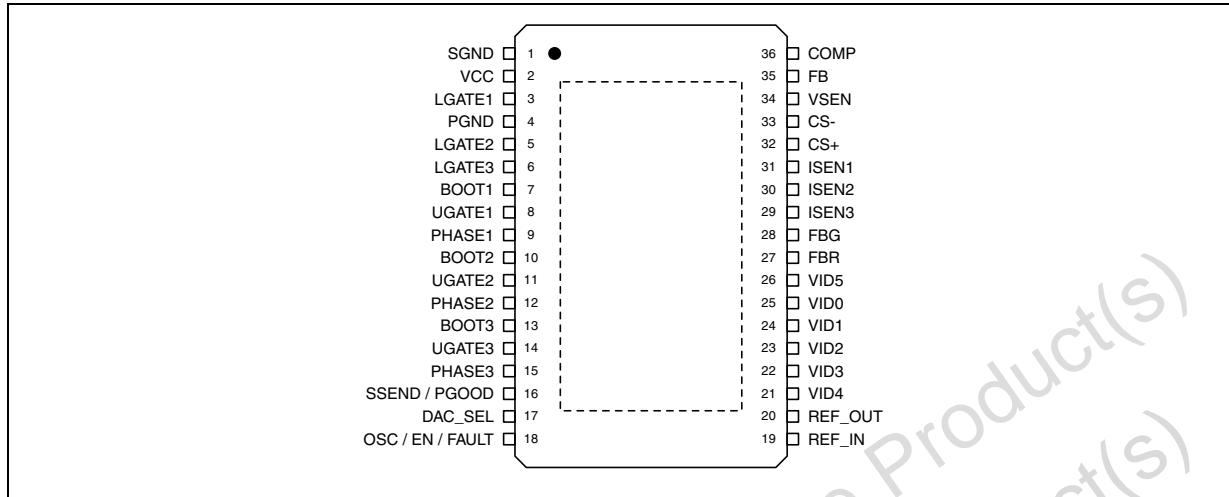

2.1 Pin description

Table 1. Pins description

Pin n°	Name	Function
1	SGND	All the internal references are referred to this pin. Connect to the PCB Signal Ground.
2	VCC	Device Power Supply and LS driver supply. Operative voltage is 12V ±15%. Filter with at least 1µF MLCC vs. ground.
3	LGATE1	Channel 1 LS Driver Output. A small series resistor helps in reducing device-dissipated power.
4	PGND	LS Drivers return path. Connect to Power ground Plane.
5	LGATE2	Channel 2 LS Driver Output. A small series resistor helps in reducing device-dissipated power.
6	LGATE3	Channel 3 LS Driver Output. A small series resistor helps in reducing device-dissipated power.
7	BOOT1	Channel 1 HS driver supply. Connect through a capacitor (100nF typ.) to PHASE1 and provide necessary Bootstrap diode. A small series resistor upstream the boot diode helps in reducing Boot capacitor overcharge.
8	UGATE1	Channel 1 HS driver output. A small series resistors helps in reducing device-dissipated power.
9	PHASE1	Channel 1 HS driver return path. It must be connected to the HS1 MOSFET source and provides return path for the HS driver of channel 1.

Table 1. Pins description (continued)

Pin n°	Name	Function
10	BOOT2	Channel 2 HS driver supply. Connect through a capacitor (100nF typ.) to PHASE2 and provide necessary Bootstrap diode. A small series resistor upstream the boot diode helps in reducing Boot capacitor overcharge.
11	UGATE2	Channel 2 HS driver output. A small series resistors helps in reducing device-dissipated power.
12	PHASE2	Channel 2 HS driver return path. It must be connected to the HS2 MOSFET source and provides return path for the HS driver of channel 2.
13	BOOT3	Channel 3 HS driver supply. Connect through a capacitor (100nF typ.) to PHASE3 and provide necessary Bootstrap diode. A small series resistor upstream the boot diode helps in reducing Boot capacitor overcharge.
14	UGATE3	Channel 3 HS driver output. A small series resistors helps in reducing device-dissipated power.
15	PHASE3	Channel 3 HS driver return path. It must be connected to the HS3 MOSFET source and provides return path for the HS driver of channel 3.
16	SSEND / PGOOD	<i>SSEND - Intel VR10 Mode.</i> Soft Start END Signal. Open Drain Output set free after SS has finished and pulled low when triggering any protection. Pull up to 5V (typ) or lower, if not used it can be left floating. <i>PGOOD - intel VR9 & AMD Hammer Mode.</i> Open Drain Output set free after SS has finished and pulled low when VSEN is lower than the relative threshold. Pull up to 5V (typ) or lower, if not used it can be left floating.
17	DAC_SEL	<i>DAC SElection pin.</i> It allows programming the DAC table for the regulation. Internally pulled-up to 5V. Short to GND to program VR9 DAC, leave floating to program K8 DAC while connect to GND through 82kΩ to program VR10 DAC. Information about the selected DAC is latched before the system start-up. See Section 7.1 for connections to enable CPU auto-detection.
18	OSC / EN / FAULT	<i>OSC:</i> It allows programming the switching frequency F_{SW} of each channel. Switching frequency can be increased according to the resistor connected from the pin vs. SGND with a gain of 4kHz/μA (see Section 14). Leaving the pin floating it programs a switching frequency of 100kHz per phase (300kHz on the load). <i>EN:</i> Forced low, the device stops operations with all MOSFETs OFF: all the protections are disabled except for Preliminary Over Voltage . When set low it resets the device from any latching condition. <i>FAULT:</i> The pin is forced high (5V) to signal an OVP / UVP FAULT: to recover from this condition, cycle VCC or the OSC pin. See Section 13 for details.

Table 1. Pins description (continued)

Pin n°	Name	Function
19	REF_IN	Reference Input for the regulation. Connect directly or through a resistor to the REF_OUT pin. See Section 10.3 for details. This pin is used as input for the protections.
20	REF_OUT	Reference Output. Connect directly or through a resistor to the REF_IN pin. See Section 10.3 for details.
21 to 26	VID4 to VID0, VID5	Voltage Identification Pins. Internally pulled up by 12.5µA to 5V, connect to SGND to program a '0' or leave floating to program a '1'. They allow programming output voltage as specified in Table 5 , Table 6 and Table 7 according to DAC_SEL status.
27	FBR	Remote Buffer Non Inverting Input. Connect to the positive side of the load to perform remote sense. See Section 16 for proper layout of this connection.
28	FBG	Remote Buffer Inverting Input. Connect to the negative side of the load to perform remote sense. See Section 16 for proper layout of this connection.
29 to 31	ISEN3 to ISEN1	LS Current Sense Pins. These pins are used for current balance phase-to-phase as well as for the system OCP. Connect through a resistor R_{ISEN} to the relative PHASEx pin. See Section 9 and Section 13.6 for details.
32	CS+	Droop Current Sense non-inverting input. Connect through $R_{PH}-C_{PH}$ network to the main inductors. Directly connect to output voltage when Droop function is not required. See Section 10.1 and Section 10.2 for details.
33	CS-	Droop Current Sense inverting input. Connect through resistor R_D to the main inductors common node. Leave floating when Droop Function is not required. See Section 10.1 and Section 10.2 for details. This pin also monitors the output for any feedback disconnection. See Section 13.4 for details.
34	VSEN	Remote Buffer Output. It manages OVP and UVP protections and PGOOD (when applicable). See Section 13 for details.
35	FB	Error Amplifier Inverting Input. Connect with a resistor R_{FB} vs. VSEN and with an $R_F - C_F$ toward COMP.
36	COMP	Error Amplifier Output. Connect with an $R_F - C_F$ vs. FB. The device cannot be disabled by pulling down this pin.
PAD	THERMAL PAD	Thermal pad connects the Silicon substrate and makes good thermal contact with the PCB to dissipate the power necessary to drive the external MOSFETs. Connect to the PGND plane with several VIAs to improve thermal conductivity.

3 Maximum Ratings

3.1 Absolute maximum ratings

Table 2. Absolute Maximum Ratings

Symbol	Parameter	Value	Unit
V_{CC}	to PGND	15	V
$V_{BOOTx} - V_{PHASEx}$	Boot Voltage	15	V
$V_{UGATEx} - V_{PHASEx}$		15	V
	LGATE _x , PHASE _x , to PGND _x	-0.3 to $V_{CC} + 0.3$	V
	VID0 to VID5	-0.3 to 5	V
	All other Pins to PGND _x	-0.3 to 7	V
V_{PHASEx}	Positive Peak Voltage; T<20ns @ 600kHz	26	V
	Negative Peak Voltage;	TBD	V

3.2 Thermal data

Table 3. Thermal data

Symbol	Parameter	Value	Unit
R_{THJA}	Thermal Resistance Junction to Ambient (Device soldered on 2s2p PC Board)	30	°C/W
R_{THJC}	Thermal Resistance Junction to Case	1	°C/W
T_{MAX}	Maximum Junction Temperature	150	°C
T_{STG}	Storage Temperature Range	-40 to 150	°C
T_J	Junction Temperature Range	0 to 125	°C
P_{TOT}	Maximum Power Dissipation at 25°C (Device soldered on 2s2p PC Board)	3.3	W

4 Electrical specifications

4.1 Electrical characteristics

Table 4. Electrical Characteristics

($V_{CC} = 12V \pm 15\%$, $T_J = 0^\circ C$ to $70^\circ C$ unless otherwise specified).

Symbol	Parameter	Test conditions	Min.	Typ.	Max.	Unit
Supply Current and Power-ON						
I_{CC}	VCC Supply current	HGATE _x and LGATE _x = OPEN BOOT _x = 12V		17		mA
I_{BOOTx}	BOOT _x Supply Current	HGATE _x = OPEN; PHASE _x to PGND _x ; BOOT _x = 12V		0.7		mA
UVLO _{VCC}	V _{CC} Turn-ON	V _{CC} Rising			9.2	V
	V _{CC} Turn-OFF	V _{CC} Falling	7			V
UVLO _{OVP}	Pre-OVP Turn-ON	V _{CC} Rising			3.8	V
	Pre-OVP Turn-OFF	V _{CC} Falling	3			V
Oscillator and Inhibit						
F_{SW}	Main Oscillator Accuracy	OSC = OPEN OSC = OPEN; $T_J = 0^\circ C$ to $125^\circ C$	90	100	110	kHz
OSC _{IL}	Disable Thresholds		0.5			V
d_{MAX}	Maximum Duty Cycle	OSC = OPEN; $I_{ISENx} = 0\mu A$		80		%
		OSC = OPEN; $I_{ISENx} = 35\mu A$		40		%
ΔV_{OSC}	PWM _x Ramp Amplitude			3		V
FAULT	Voltage at Pin OSC	OVP Active		5		V
Reference and DAC						
V_{VID}	Output Voltage Accuracy	FBR = V _{OUT} ; FBG = GND _{OUT} ; VR10 and VR9 DACs; V _{OUT} > 1V	-0.7		0.7	%
		FBR = V _{OUT} ; FBG = GND _{OUT} ; K8 DAC; V _{OUT} > 1V	-1		1	%
I_{VID}	VID Pull-up Current			25		μA
VID _{IL}	VID Input Thresholds	VR9 and VR10 Mode; Input Low K8 Mode; Input Low			0.4 0.8	V V
		VR9 and VR10 Mode; Input Low K8 Mode; Input Low	0.8 2			V V
VID _{IH}						

Table 4. Electrical Characteristics (continued)
 ($V_{CC} = 12V \pm 15\%$, $T_J = 0^\circ C$ to $70^\circ C$ unless otherwise specified).

Symbol	Parameter	Test conditions	Min.	Typ.	Max.	Unit
Error Amplifier and Remote Buffer						
A_0	EA DC Gain			80		dB
SR	Slew Rate	COMP = 10pF to SGND		15		V/ μ s
	RB DC Gain			1		V/V
CMRR	Remote Buffer Common Mode Rejection Ratio			40		dB
Differential Current Sensing and Offset						
I_{OCTH}	Over Current Threshold			35		μ A
k_{IDROOP}	Droop Current Deviation	$I_{DROOP} = 0$ to 105μ A; $R_D = 5.1k\Omega$	-3		3	μ A
I_{OFFSET}	Offset Current		10	11.5	13	μ A
Gate Drivers						
t_{RISE_UGATEx}	HS Rise Time	BOOTx - PHASEx = 10V; C_{UGATEx} to PHASEx = 3.3nF		15		ns
I_{UGATEx}	HS Source Current	BOOTx - PHASEx = 10V		1.5		A
R_{UGATEx}	HS Sink Resistance	BOOTx - PHASEx = 12V		2.5		Ω
t_{RISE_LGATEx}	LS Rise Time	VCC = 10V; C_{LGATEx} to PGNDx = 5.6nF		20		ns
I_{LGATEx}	LS Source Current	VCC = 10V		1.5		A
R_{LGATEx}	LS Sink Resistance	VCC = 12V		1.8		Ω
Protections						
OVP	Over Voltage Protection	VSEN Rising, VR10 and K8 Mode	1.85	1.9	1.95	V
		VSEN Rising, VR9 Mode	2.05	2.1	2.15	V
Pre-OVP	Preliminary Over voltage Protection	FBR Rising, VR10 and K8 Mode	1.8	1.9	2.0	V
		FBR Rising, VR9 Mode	2.0	2.1	2.2	V
		Hysteresis		300		mV
UVP	Under Voltage Protection	VSEN Falling; Below VID	-475	-400	-325	mV
PGOOD	PGOOD Threshold	K8 and VR9 Mode; VSEN Falling; Below VID	-280	-230	-180	mV
$V_{SSEND}/PGOOD$	SSEND / PGOOD Voltage Low	$I = -4mA$			0.4	V

5 Typical application circuit and block diagram

5.1 Application circuit

Figure 2. Typical application circuit

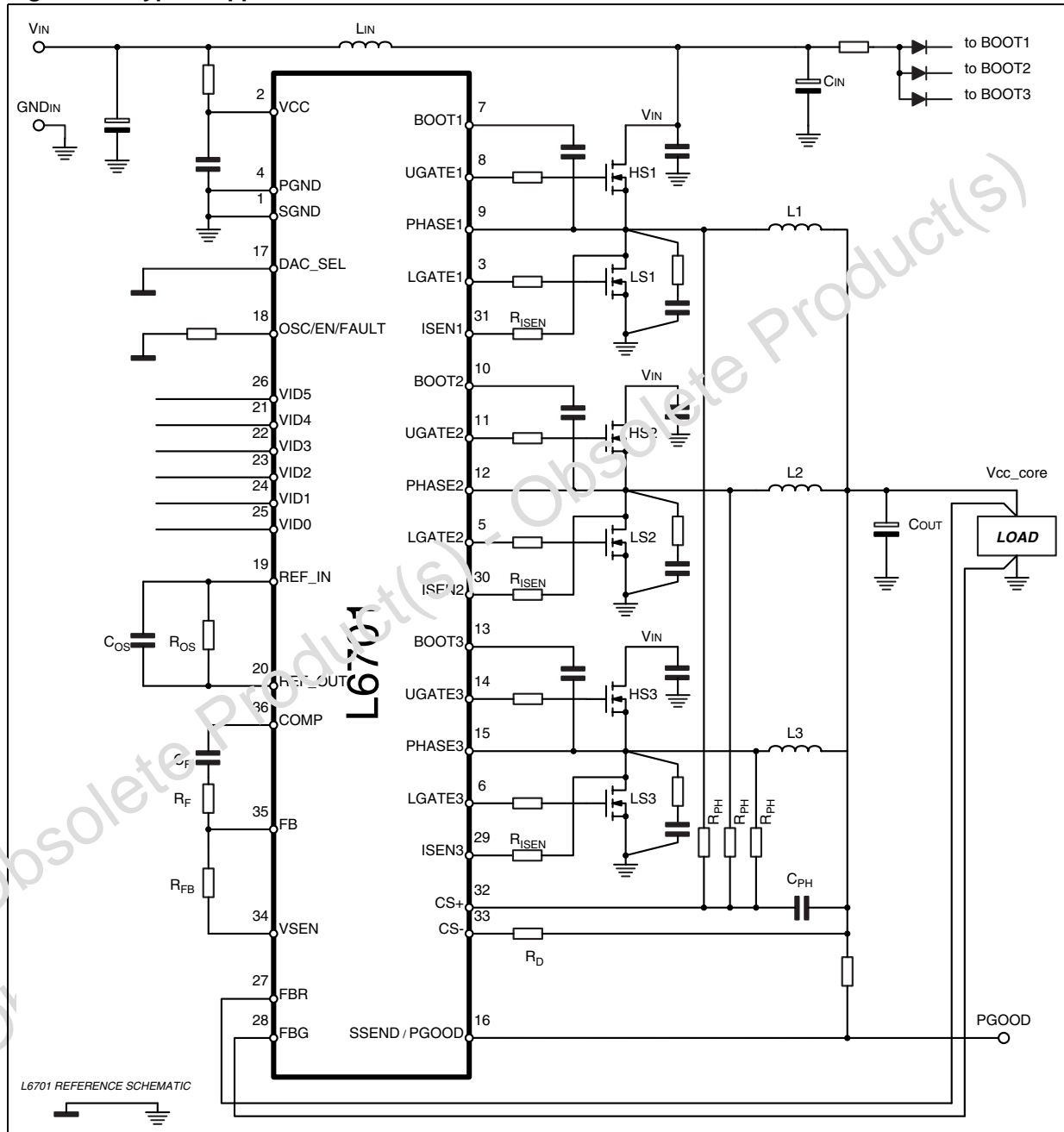
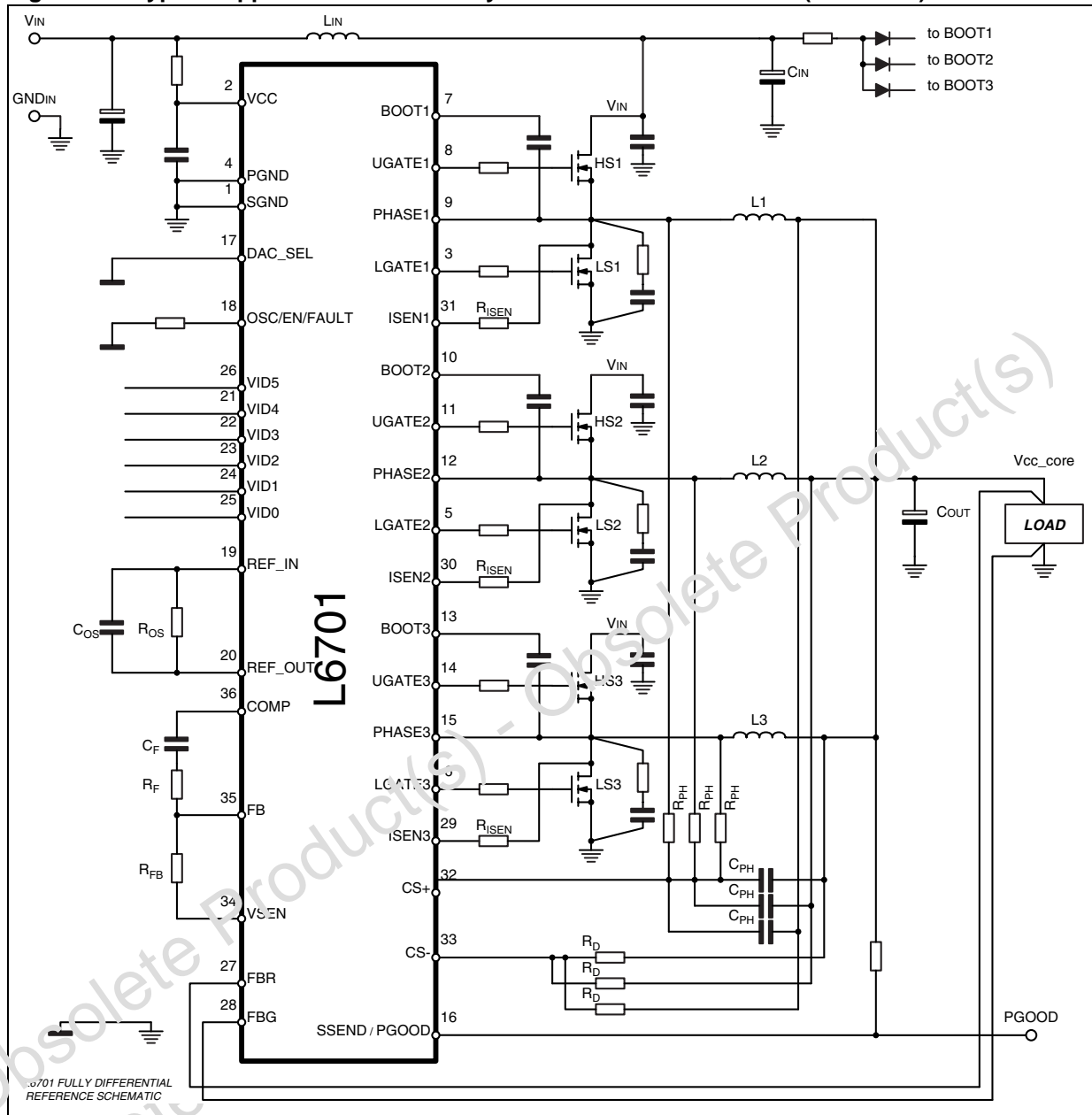
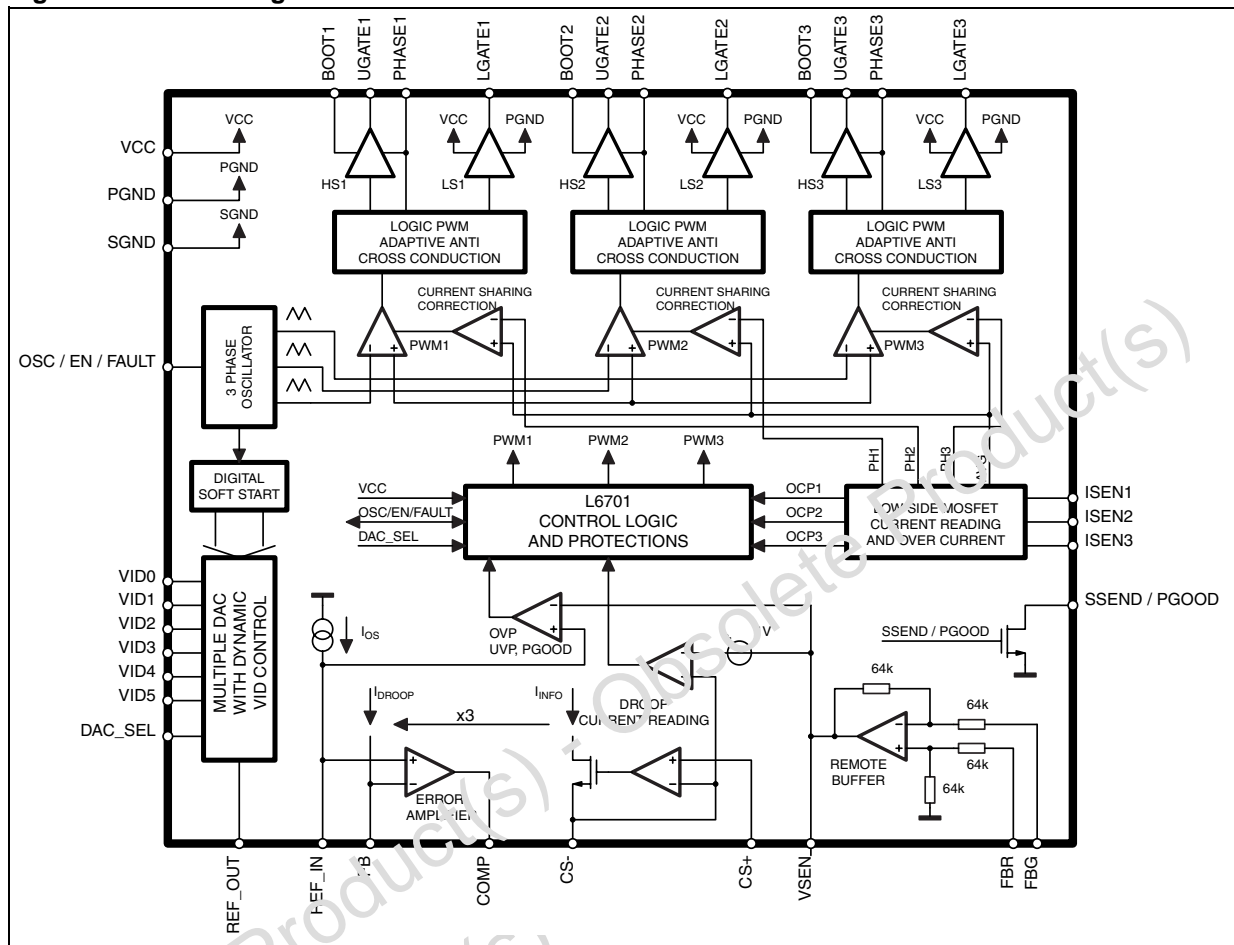

Figure 3. Typical Application Circuit: Fully Differential Current Sense (Pat.Pend.)



5.2 Block diagram

Figure 4. Block diagram



6 VID Tables

Table 5. Voltage IDentification (VID) for Intel VR10 DAC.

VID4	VID3	VID2	VID1	VID0	VID5	Output Voltage ⁽¹⁾	VID4	VID3	VID2	VID1	VID0	VID5	Output Voltage ⁽¹⁾
0	1	0	1	0	1	1.6000	1	1	0	1	0	1	1.2000
0	1	0	1	1	0	1.5875	1	1	0	1	1	0	1.1875
0	1	0	1	1	1	1.5750	1	1	0	1	1	1	1.1750
0	1	1	0	0	0	1.5625	1	1	1	0	0	0	1.1625
0	1	1	0	0	1	1.5500	1	1	1	0	0	1	1.1500
0	1	1	0	1	0	1.5375	1	1	1	0	1	0	1.1375
0	1	1	0	1	1	1.5250	1	1	1	0	1	1	1.1250
0	1	1	1	0	0	1.5125	1	1	1	1	0	0	1.1175
0	1	1	1	0	1	1.5000	1	1	1	1	0	1	1.1000
0	1	1	1	1	0	1.4875	1	1	1	1	1	0	OFF
0	1	1	1	1	1	1.4750	1	1	1	1	1	1	OFF
1	0	0	0	0	0	1.4625	0	0	0	0	0	0	1.0875
1	0	0	0	0	1	1.4500	0	0	0	0	0	1	1.0750
1	0	0	0	1	0	1.4375	0	0	0	0	1	0	1.0625
1	0	0	0	1	1	1.4250	0	0	0	0	1	1	1.0500
1	0	0	1	0	0	1.4125	0	0	0	1	0	0	1.0375
1	0	0	1	0	1	1.4000	0	0	0	1	0	1	1.0250
1	0	0	1	1	0	1.3875	0	0	0	1	1	0	1.0125
1	0	0	1	1	1	1.3750	0	0	0	1	1	1	1.0000
1	0	1	0	0	0	1.3625	0	0	1	0	0	0	0.9875
1	0	1	0	0	1	1.3500	0	0	1	0	0	1	0.9750
1	0	1	0	1	0	1.3375	0	0	1	0	1	0	0.9625
1	0	1	0	1	1	1.3250	0	0	1	0	1	1	0.9500
1	0	1	1	0	0	1.3125	0	0	1	1	0	0	0.9375
1	0	1	1	0	1	1.3000	0	0	1	1	0	1	0.9250
1	0	1	1	1	0	1.2875	0	0	1	1	1	0	0.9125
1	0	1	1	1	1	1.2750	0	0	1	1	1	1	0.9000
1	1	0	0	0	0	1.2625	0	1	0	0	0	0	0.8875
1	1	0	0	0	1	1.2500	0	1	0	0	0	1	0.8750
1	1	0	0	1	0	1.2375	0	1	0	0	1	0	0.8625

Table 5. Voltage Identification (VID) for Intel VR10 DAC. (continued)

VID4	VID3	VID2	VID1	VID0	VID5	Output Voltage ⁽¹⁾	VID4	VID3	VID2	VID1	VID0	VID5	Output Voltage ⁽¹⁾
1	1	0	0	1	1	1.2250	0	1	0	0	1	1	0.8500
1	1	0	1	0	0	1.2125	0	1	0	1	0	0	0.8375

1. Since the VIDx pins program the maximum output voltage, according to VR10.x specifications, the device automatically regulates to a voltage 19mV lower avoiding the use of any external components to lower the output voltage. This improves the system tolerance performance since the reference already offset is trimmed in production within $\pm 0.7\%$.

Table 6. Voltage Identification (VID) for Intel VR9 DAC (VID5 doesn't care)

VID4	VID3	VID2	VID1	VID0	Output Voltage ⁽¹⁾	VID4	VID3	VID2	VID1	VID0	Output Voltage ⁽¹⁾
0	0	0	0	0	1.850	1	0	0	0	0	1.450
0	0	0	0	1	1.825	1	0	0	0	1	1.425
0	0	0	1	0	1.800	1	0	0	1	0	1.400
0	0	0	1	1	1.775	1	0	0	1	1	1.375
0	0	1	0	0	1.750	1	0	1	0	0	1.350
0	0	1	0	1	1.725	1	0	1	0	1	1.325
0	0	1	1	0	1.700	1	0	1	1	0	1.300
0	0	1	1	1	1.675	1	0	1	1	1	1.275
0	1	0	0	0	1.650	1	1	0	0	0	1.250
0	1	0	0	1	1.625	1	1	0	0	1	1.225
0	1	0	1	0	1.600	1	1	0	1	0	1.200
0	1	0	1	1	1.575	1	1	0	1	1	1.175
0	1	1	0	0	1.550	1	1	1	0	0	1.150
0	1	1	0	1	1.525	1	1	1	0	1	1.125
0	1	1	1	0	1.500	1	1	1	1	0	1.100
0	1	1	1	1	1.475	1	1	1	1	1	OFF

1. Since the VIDx pins program the maximum output voltage, the device automatically regulates to a voltage 19mV lower avoiding the use of any external components to lower the output voltage. This improves the system tolerance performance since the reference already offset is trimmed in production within $\pm 0.7\%$.

Table 7. Voltage IDentification (VID) for AMD Hammer DAC

VID5	VID4	VID3	VID2	VID1	VID0	Output Voltage	VID5	VID4	VID3	VID2	VID1	VID0	Output Voltage
1	0	0	0	0	0	1.550	0	0	0	0	0	0	1.575
	0	0	0	0	1	1.525		0	0	0	0	1	1.550
	0	0	0	1	0	1.500		0	0	0	1	0	1.525
	0	0	0	1	1	1.475		0	0	0	1	1	1.500
	0	0	1	0	0	1.450		0	0	1	0	0	1.475
	0	0	1	0	1	1.425		0	0	1	0	1	1.450
	0	0	1	1	0	1.400		0	0	1	1	0	1.425
	0	0	1	1	1	1.375		0	0	1	1	1	1.400
	0	1	0	0	0	1.350		0	1	0	0	0	1.375
	0	1	0	0	1	1.325		0	1	0	0	1	1.350
	0	1	0	1	0	1.300		0	1	0	1	0	1.325
	0	1	0	1	1	1.275		0	1	0	1	1	1.300
	0	1	1	0	0	1.250		0	1	1	0	0	1.275
	0	1	1	0	1	1.225		0	1	1	0	1	1.250
	0	1	1	1	0	1.200		0	1	1	1	0	1.225
	0	1	1	1	1	1.175		0	1	1	1	1	1.200
	1	0	0	0	0	1.150		1	0	0	0	0	1.175
	1	0	0	0	1	1.125		1	0	0	0	1	1.150
	1	0	0	0	0	1.100		1	0	0	1	0	1.125
	1	0	0	1	1	1.075		1	0	0	1	1	1.100
	1	0	1	0	0	1.050		1	0	1	0	0	1.075
	1	0	1	0	1	1.025		1	0	1	0	1	1.050
	1	0	1	1	0	1.000		1	0	1	1	0	1.025
	1	0	1	1	1	0.975		1	0	1	1	1	1.000
	1	1	0	0	0	0.950		1	1	0	0	0	0.975
	1	1	0	0	1	0.925		1	1	0	0	1	0.950
	1	1	0	1	0	0.900		1	1	0	1	0	0.925
	1	1	0	1	1	0.875		1	1	0	1	1	0.900
	1	1	1	0	0	0.850		1	1	1	0	0	0.875
	1	1	1	0	1	0.825		1	1	1	0	1	0.850
	1	1	1	1	0	0.800		1	1	1	1	0	0.825
	1	1	1	1	1	OFF		1	1	1	1	1	OFF

7 Configuring the Device: DAC Selection

Multiple DACs need to be configured before the system start-up by programming the apposite pin DAC_SEL. The embedded DAC allows to regulate the output voltage with a tolerance of $\pm 0.7\%$ recovering from offsets and manufacturing variations. In case of selecting VR9 and VR10 Mode, the device automatically introduces a -19mV offset to the regulated voltage (see [Table 5](#) and [Table 6](#)) in order to avoid any external offset circuitry to worsen the guaranteed accuracy and, as a consequence, the calculated system TOB. In case of selecting the K8 DAC, VID5 gives the option to introduce +25mV offset to the regulation (See [Table 7](#)).

Output voltage is programmed through the VID pins: they are inputs of an internal DAC that is realized by means of a series of resistors providing a partition of the internal voltage reference. The VID code drives a multiplexer that selects a voltage on a precise point of the divider. The DAC output is delivered to an amplifier obtaining the voltage reference available on PEF_OUT.

According to the selected DAC, the device also changes the protection thresholds as a consequence of different CPU specifications, see [Table 8](#) for details.

Table 8. L6701 Configuration

DAC_SEL	OPERATIVE MODE	OVP & Pre-OVP	UVP	PGOOD
OPEN	AMD K8 +25mV (Driven by VID5)	1.9V Fixed	-400mV	-230mV
82k Ω to GND	Intel VR10 -19mV	1.9V Fixed	-400mV	SSEND
GND	Intel VR9 -19mV	2.1V Fixed	-400mV	-230mV

7.1 Single-Wire CPU Automatic Detection

L6701 has been designed to automatically detect the Intel CPU connected by monitoring the DAC_SEL pin status at the start-up so modifying the DAC table accordingly (see [Table 8](#)). In fact, by directly connecting the DAC_SEL pin with #BOOTSEL pin of the CPU, the controller automatically recognize the different technology steps of the CPU so modifying the DAC table accordingly.

See CPU related documentation for further details about compatibility.

8 Driver Section

The integrated high-current drivers allow using different types of power MOS (also multiple MOS to reduce the equivalent $R_{DS(on)}$), maintaining fast switching transition.

The drivers for the high-side MOSFETs use BOOTx pins for supply and PHASEx pins for return. The drivers for the low-side MOSFETs use the VCC pin for supply and PGND pin for return.

The controller embodies a anti-shoot-through and adaptive dead-time control to minimize low side body diode conduction time maintaining good efficiency saving the use of Schottky diodes: when the high-side MOSFET turns off, the voltage on its source begins to fall; when the voltage reaches 2V, the low-side MOSFET gate drive is suddenly applied. When the low-side MOSFET turns off, the voltage at LGATEx pin is sensed. When it drops below 1V, the high-side MOSFET gate drive is suddenly applied. If the current flowing in the inductor is negative, the source of high-side MOSFET will never drop. To allow the low-side MOSFET to turn-on even in this case, a watchdog controller is enabled: if the source of the high-side MOSFET does not drop, the low side MOSFET is switched on so allowing the negative current of the inductor to recirculate. This mechanism allows the system to regulate even if the current is negative.

Power conversion input is flexible: 5V, 12V bus or any bus that allows the conversion (See maximum duty cycle limitations) can be chosen freely.

8.1 Power Dissipation

L6701 embeds high current MOSFET drivers for both high side and low side MOSFETs: it is then important to consider the power that the device is going to dissipate in driving them in order to avoid overcoming the maximum junction operative temperature. In addition, since the device has an exposed pad to better dissipate the power, the thermal resistance between junction and ambient, consequent to the layout is also important: thermal pad need to be soldered to the PCB ground plane through several VIAs in order to facilitate the heat dissipation.

Two main terms contribute in the device power dissipation: bias power and drivers' power.

- Device Power (P_{DC}) depends on the static consumption of the device through the supply pins and it is simply quantifiable as follow (assuming to supply HS and LS drivers with the same VCC of the device):

$$P_{DC} = V_{CC} \cdot (I_{CC} + 3 \cdot I_{CCDRx} + 3 \cdot I_{BOOTx})$$

- Drivers' power is the power needed by the driver to continuously switch on and off the external MOSFETs; it is a function of the switching frequency and total gate charge of the selected MOSFETs. It can be quantified considering that the total power P_{SW} dissipated to switch the MOSFETs (easy calculable) is dissipated by three main factors: external gate resistance (when present), intrinsic MOSFET resistance and intrinsic driver resistance. This last term is the important one to be determined to calculate the device power dissipation. The total power dissipated to switch the MOSFETs results:

$$P_{SW} = 3 \cdot F_{SW} \cdot (Q_{GHS} \cdot V_{BOOT} + Q_{GLS} \cdot V_{CCDRx})$$

External gate resistors helps the device to dissipate the switching power since the same power P_{SW} will be shared between the internal driver impedance and the external resistor resulting in a general cooling of the device.

Figure 5. Dissipated Power

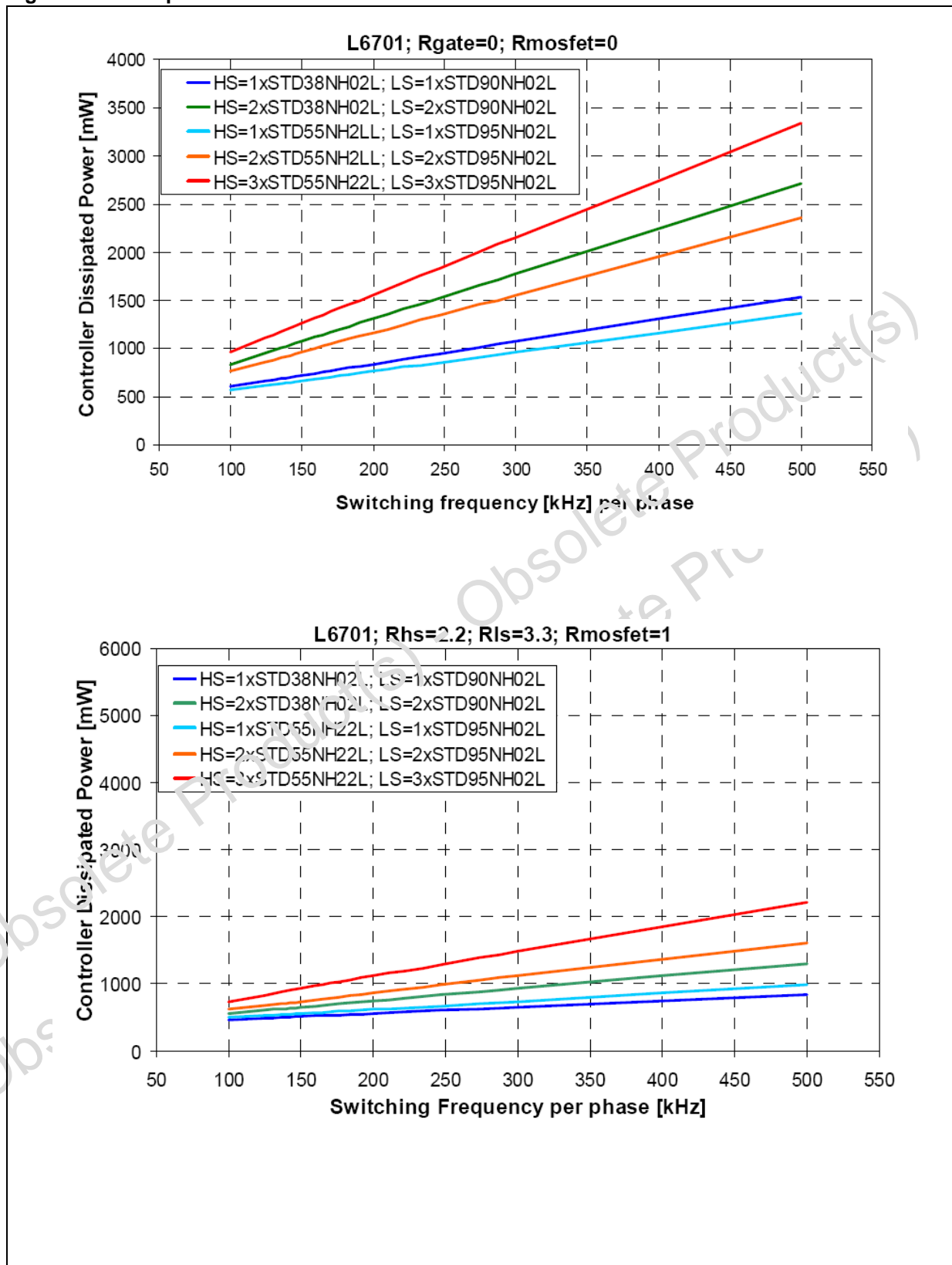

9 Current Sharing Loop and Current Reading

9.1 Current Sharing Loop

L6701 embeds two separate Current Reading circuitries used to perform Current Sharing and OCP through ISENx pins and Voltage Positioning (Droop Function) through CS+ and CS- pins (See [Section 10](#)).

Current sharing control loop and connections are reported in [Figure 6](#): the current read through the ISENx pins is converted into a current I_{INFOx} proportional to the current delivered by each phase and the information about the average current I_{AVG} = ΣI_{INFOx} / 3 is internally built into the device. The error between the read current I_{INFOx} and the reference I_{AVG} is then converted into a voltage that with a proper gain is used to adjust the duty cycle whose dominant value is set by the voltage error amplifier in order to equalize the current carried by each phase.

9.2 Current Reading for Current Sharing

The current flowing trough each phase is read using the voltage drop across the low side MOSFETs R_{DS(on)} or across a sense resistor in its series and it is internally converted into a current. The trans-conductance ratio is issued by the external resistor R_{ISEN} placed outside the chip between ISENx and the reading point (usually the LS MOSFET Drain).

The current sense circuit tracks the current information for a time T_{TRACK} centered in the middle of the LS conduction time and holds the tracked information during the rest of the period. The current that flows from the ISENx pin is the current information used by the device to perform current sharing and OCP and it is given by:

$$I_{ISENx} = \frac{R_{dsON}}{R_{ISEN}} \cdot I_{PHASEx} = I_{INFOx}$$

where R_{DS(on)} is the ON resistance of the low side MOSFET and R_{ISEN} is the trans-conductance resistor connected between the ISENx pins and the LS Drain; I_{PHASEx} is the current carried by the relative phase and I_{INFOx} is the current information signal reproduced internally. R_{ISENx} is designed according to the Over Current Protection: see [Section 13.6](#) for details.

Figure 6. Current Sharing Loop and Current Reading Connections

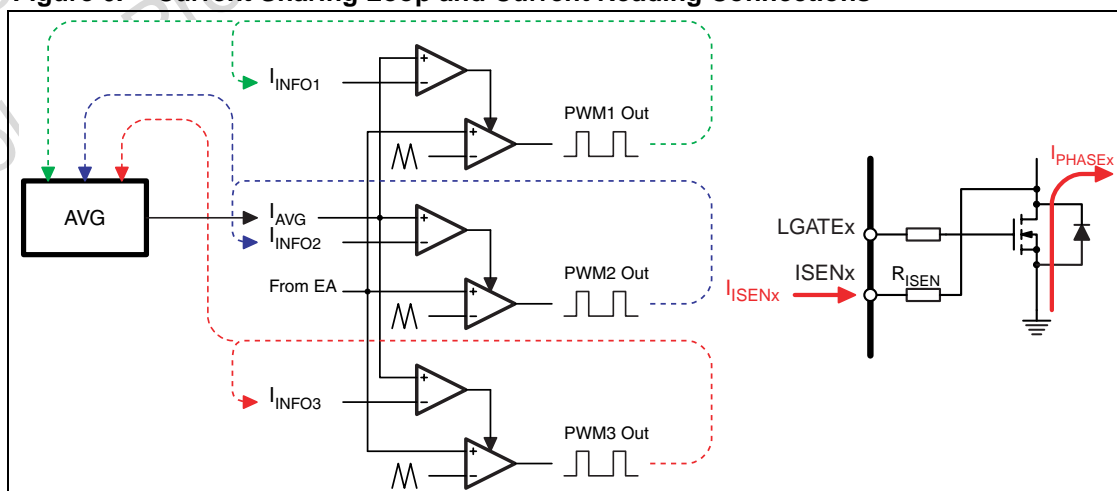

$$\frac{L}{DCR} = \frac{R_{PH} \cdot C_{PH}}{3} \Rightarrow I_{CS} = \frac{I_{OUT}}{3} \cdot \frac{DCR}{R_D}$$

The device forces $I_{DROOP} = I_{CS} \times 3$, proportional to the read current, into the feedback resistor R_{FB} implementing the load regulation dependence. The output characteristic vs. load current is then given by (Offset disabled):

$$V_{OUT} = VID - R_{FB} \cdot I_{DROOP} = VID - R_{FB} \cdot \frac{DCR}{R_D} \cdot I_{OUT} = VID - R_{LL} \cdot I_{OUT}$$

Where R_{LL} is the resulting load-line resistance implemented by the system.

The whole power supply can be then represented by a "real" voltage generator with an equivalent output resistance R_{LL} and a voltage value of VID.

R_{FB} resistor can be then designed according to the R_{LL} specifications as follow:

$$R_{FB} = R_{LL} \cdot \frac{R_D}{DCR}$$

where R_D is typically designed to have $I_{CS} = 35\mu A$ at the maximum output current (OCP).

Caution: Droop function is optional, in case it is not desired, the Current Sense circuit can be modified so that the device always read a null current (See [Figure 8](#)). To do this, it is enough to connect CS+ directly to the output voltage leaving CS- unconnected. The reaction will keep CS+ and CS- at the same voltage, always reading a null current and also assuring the FB disconnection protection to be effective.

Figure 8. Droop Function Current Reading Network

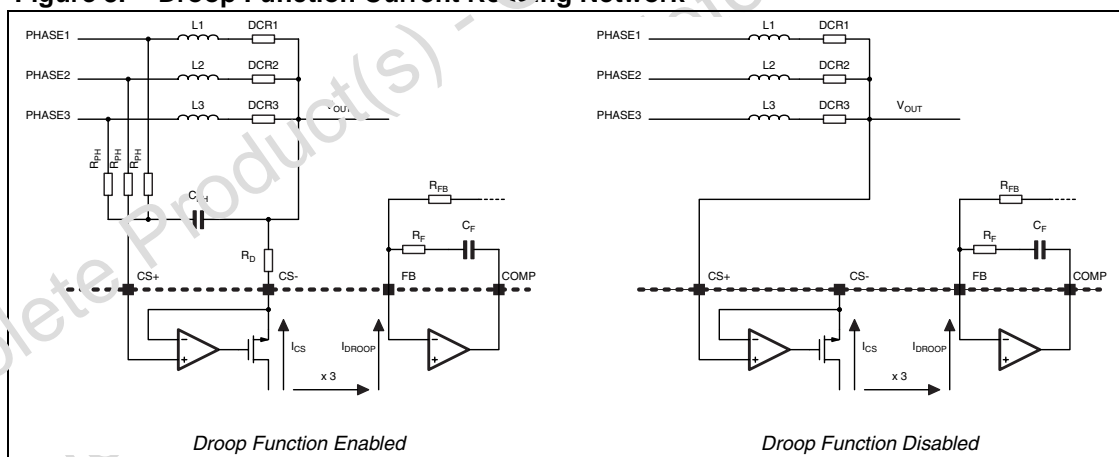

10.2 Fully-Differential Load-Line (Droop Function - Optional)

Fully-Differential current-reading for voltage-positioning allows the designer to save time in the application fine-tuning since the BOM so obtained becomes layout-independent. The patent-pending topology offered by L6701 allow implementing fully-differential current-sense still using only two current-sense pins (CS+ and CS-). [Figure 9](#) shows the typical Current-Sense Circuit used to implement the Fully-Differential Droop-Function. The current flowing across the three inductors is read through an $R_{PH} - C_{PH}$ filter for each phase as well as an R_D is required for each phase to program the trans-conductance-gain. As previously mentioned, a current I_{CS} proportional to the average of the currents of the three phases is internally generated, mirrored

and, multiplied by three, sourced by the FB pin (I_{DROOP}). R_{FB} gives the final gain to program the desired load-line slope.

As before, the voltage positioning equations results (See [Figure 9](#)):

$$I_{CS} = I_{OUT} \cdot \frac{1 + s \cdot L / DCR}{1 + s \cdot R_{PH} \cdot C_{PH}} \cdot \frac{DCR}{R_D}$$

As a consequence:

$$\frac{L}{DCR} = R_{PH} \cdot C_{PH} \Rightarrow I_{CS} = I_{OUT} \cdot \frac{DCR}{R_D}$$

The device forces $I_{DROOP} = I_{CS} \times 3$, proportional to the read current, into the feedback resistor R_{FB} implementing the load regulation dependence. The output characteristic vs. load current is then given by (Offset disabled):

$$V_{OUT} = VID - R_{FB} \cdot I_{DROOP} = VID - 3 \cdot R_{FB} \cdot \frac{DCR}{R_D} \cdot I_{OUT} = VID - R_{LLDIFF} \cdot I_{OUT}$$

Where R_{LLDIFF} is the resulting differential load-line resistance implemented by the system. The whole power supply can be then represented by a "real" voltage generator with an equivalent output resistance R_{LLDIFF} and a voltage value of VID .

R_{FB} resistor can be then designed according to the Load-Line (R_{LLDIFF}) specifications as follow:

$$R_{FB} = \frac{R_{LLDIFF} \cdot R_D}{3 \cdot DCR}$$

where R_D is typically designed to have $I_{CS} = 3.5 \mu A$ at the maximum output current (OCP).

[Table 9](#) contains a quick-reference guide to design applications with typical and/or differential current sense.

Figure 9. Fully Differential Load-Line Current-Reading (pat. pend.)

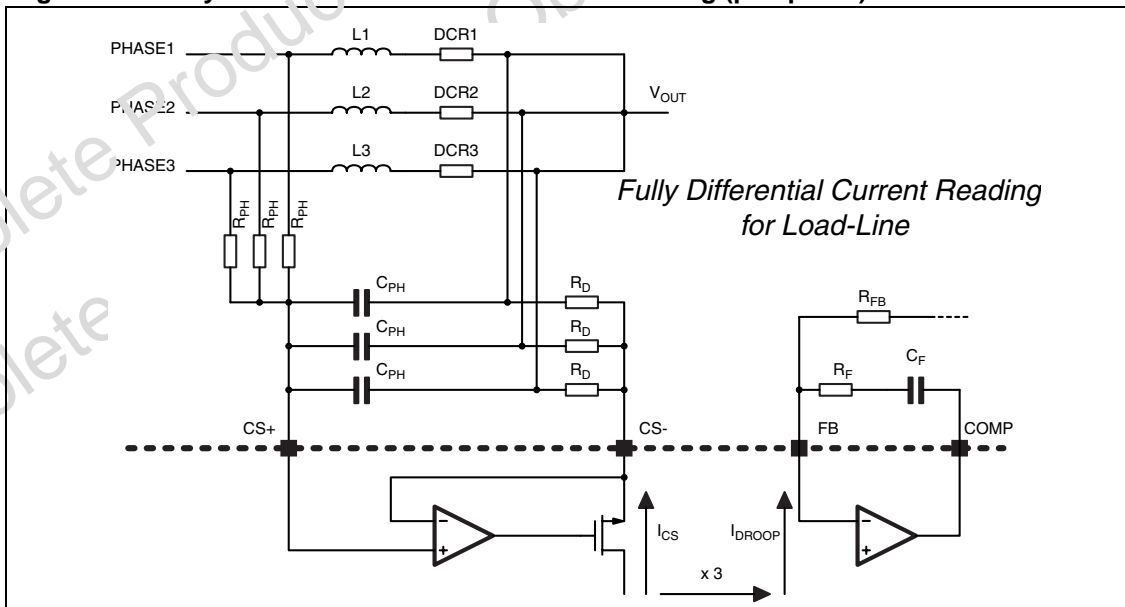

Table 9. Comparison between different load-line implementations.

	Fully-Differential LL	Non-Fully-Differential LL
Layout-insensitive BOM	Y	N
Time-Constant Matching	$\frac{L}{DCR} = R_{PH} \cdot C_{PH}$	$\frac{L}{DCR} = \frac{R_{PH} \cdot C_{PH}}{3}$
R_D Design (given OCP th.)	$R_D = OCP \cdot \frac{DCR}{35\mu}$	$R_D = \frac{OCP}{3} \cdot \frac{DCR}{35\mu}$
R_{FB} Design (given R_{LL})	$R_{FB} = \frac{R_{LL}}{3} \cdot \frac{R_D}{DCR}$	$R_{FB} = R_{LL} \cdot \frac{R_D}{DCR}$
R_{LL} (given R_D and R_{FB})	$R_{LL} = 3 \cdot \frac{DCR}{R_D} \cdot R_{FB}$	$R_{LL} = \frac{DCR}{R_D} \cdot R_{FB}$

10.3 Offset (Optional)

Positive offset can be added to the programmed reference by connecting a R_{OS} resistor between the REF_OUT and REF_IN pins. Referring to [Figure 7](#), a constant current ($I_{OS}=11.5\mu A$) is sourced from the REF_IN pin as soon as the device is enabled, so programming a fixed voltage drop across R_{OS} : this voltage is directly added to the programmed reference giving the desired offset to the output voltage as follow:

$$V_{OS} = R_{OS} \cdot I_{OS}$$

Offset current is suddenly sourced from REF_IN pin as soon as the device implements Soft-Start: to avoid having steps during soft-start, the introduction of C_{OS} (in parallel to R_{OS}) is required. The resulting time constant need to be negligible with respect to the soft-start time as well as long enough to smooth the initial step. Typical values are in the range of few hundreds of nF.

Offset function can be easily disabled simply setting $R_{OS} = 0$.

Caution: Offset automatically given by the DAC selection differs from the offset implemented through the OFFSET pin: the built-in feature is trimmed in production and assures $\pm 0.7\%$ accuracy over load and line variations.

10.4 Remote Voltage Sense

L6701 embeds a Remote Sense Buffer to sense remotely the regulated voltage without any additional external components. In this way, the output voltage programmed is regulated between the remote buffer inputs compensating motherboard or connector losses. The device senses the output voltage remotely through the pins FBR and FBG (FBR is for the regulated voltage sense while FBG is for the ground sense) and reports this voltage internally at VSEN pin with unity gain eliminating the errors. Keeping the FBR and FBG traces parallel and guarded by a power plane results in common mode coupling for any picked-up noise.

10.5 Maximum Duty Cycle limitation

To provide proper time for current-reading in order to equalize the current carried by each phase, the device implements a duty-cycle limitation. This limitation is not fixed but it is linearly variable with the current delivered to the load as follow:

$$T_{ON(max)} = \begin{cases} 0.80 \cdot T_{SW} & I_{ISEN_x} = 0\mu A \\ 0.40 \cdot T_{SW} & I_{ISEN_x} = 35\mu A \end{cases}$$

Duty Cycle limitation is variable with the delivered current to provide fast load transient response at light load as well as assuring robust over-current protection.

Figure 10 shows the maximum output voltage that the device is able to regulate considering the T_{ON} limitation imposed by the previous relationship. If the desired output characteristic crosses the limited- T_{ON} maximum output voltage, the output resulting voltage will start to drop after the cross-point. In this case, the output voltage starts to decrease following the resulting characteristic (dotted in Figure 10) until UVP is detected or anyway until $I_{ISEN_x} = 35\mu A$.

Figure 10. Maximum Duty Cycle limitation

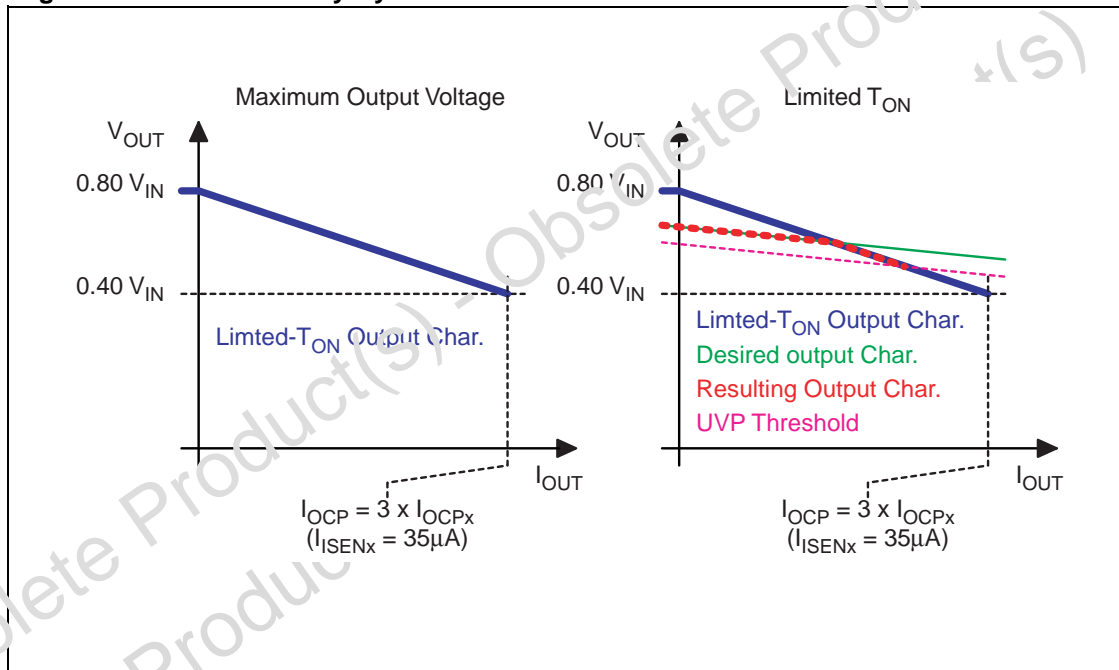

11 Dynamic VID Transitions

L6701 is able to manage Dynamic VID Code changes in all its operative modes (VR10, K8 and also VR9) so allowing Output Voltage modification during normal device operation. PGOOD (when applicable), OVP and UVP signals are masked during every VID transition and they are re-activated after the transition finishes with a 32 clock cycles delay to prevent from false triggering.

When changing dynamically the regulated voltage (D-VID), the system needs to charge or discharge the output capacitor accordingly. This means that an extra-current

$$I_{D-VID} = C_{OUT} \cdot dV_{OUT}/dT_{VID}$$

needs to be delivered, especially when increasing the output regulated voltage and it must be considered when setting the over current threshold. In the previous relationship, dV_{OUT} is the selected DAC LSB (12.5mV for VR10 DAC or 25mV for both VR9 and K8 DACs) and T_{VID} is the time interval between each LSB transition (typically externally driven). Overcoming the OC threshold during the dynamic VID causes the device to enter the constant current limitation slowing down the output voltage dV/dt also causing the failure in the D-VID test.

Figure 11. Dynamic VID Transitions

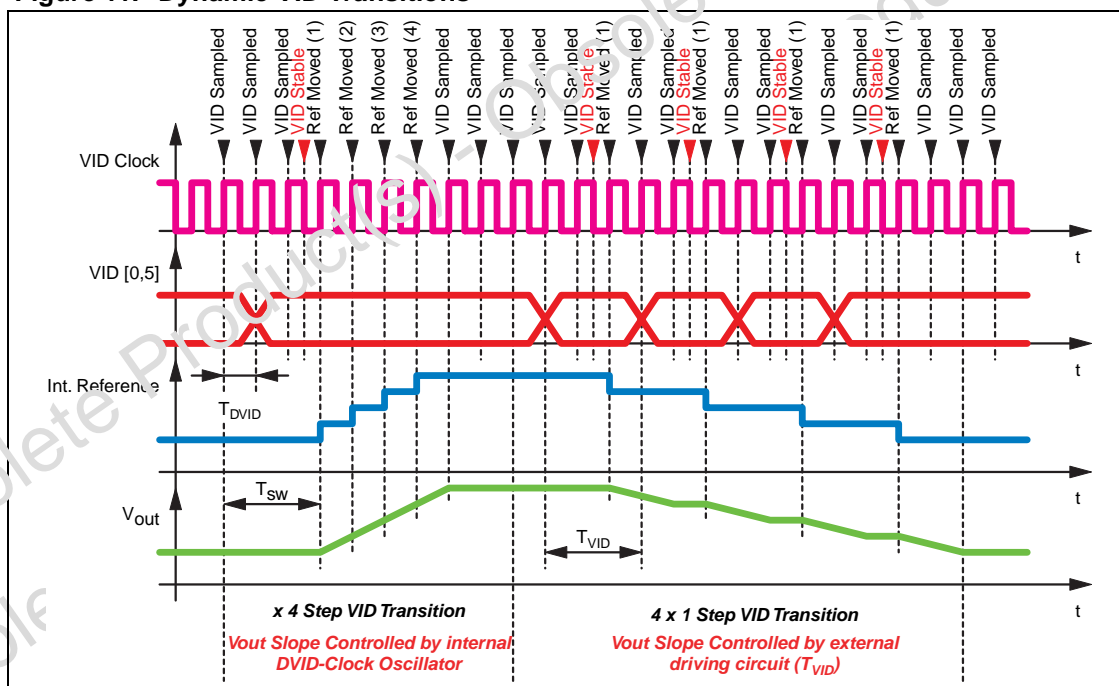

L6701 checks for VID code modifications (See [Figure 11](#)) on the rising edge of an internal additional DVID-clock and waits for a confirmation on the following falling edge. Once the new code is stable, on the next rising edge, the reference starts stepping up or down in LSB increments every VID-clock cycle until the new VID code is reached. During the transition, VID code changes are ignored; the device re-starts monitoring VID after the transition has finished on the next rising edge available. VID-clock frequency (F_{DVID}) depends on the operative mode selected: for VR10 Mode it is equal to three times the system switching frequency programmed for each phase ($F_{DVID} = 3 \times F_{SW}$) to assure compatibility with the specifications while, for VR9 and K8, this frequency is lowered to $F_{DVID} = F_{SW}$.

Caution: If the new VID code is more than 1 LSB different from the previous, the device will execute the transition stepping the reference with the DVID-clock frequency F_{DVID} until the new code has reached: for this reason it is recommended to carefully control the VID change rate in order to carefully control the slope of the output voltage variation especially in VR10 mode.

Warning: DVID sample and hold clock depends on the switching frequency F_{SW} . To correctly perform DVID transition so following the VID change rate, it is required to have at least 2 complete cycles of the F_{DVID} clock between every VID transition. If the VID update-rate is, for example, $5\mu\text{sec.}$, the minimum operating frequency results to be $F_{SW} > 133\text{kHz}$ in VR10 mode.

Obsolete Product(s) - Obsolete Product(s)
Obsolete Product(s) - Obsolete Product(s)

12 Soft Start

L6701 implements a soft-start to smoothly charge the output filter avoiding high in-rush currents to be required to the input power supply. The device increases the reference from zero up to the programmed value in 2048 clock periods and the output voltage increases accordingly with closed loop regulation. At the end of the digital Soft-Start, SSEND/PGOOD signal is set free.

Protections are active during this phase; Under Voltage is enabled when the reference voltage reaches 0.6V while Over Voltage is always enabled with a threshold dependent on the selected Operative Mode. DAC table information is frozen just before initializing the Soft-Start.

The device implements Soft-Start only when all the power supplies are above their own turn-on thresholds and the EN pin is set free.

12.1 Low-Side-Less Startup (LSLess)

In order to avoid any kind of negative undershoot and dangerous return from the load during start-up, L6701 performs a special sequence in enabling LS driver to switch: during the soft-start phase, the LS driver results disabled (LS = OFF) until the HS starts to switch. This avoid the dangerous negative spike on the output voltage that can happen if starting over a pre-biased output (See [Figure 12](#)).

This particular feature of the device masks the LS turn-on only from the control loop point of view: protections by-pass this turning ON the LS MOSFET in case of need.

Figure 12. LSLess Startup (left) vs. Non-LSLess Startup (right)

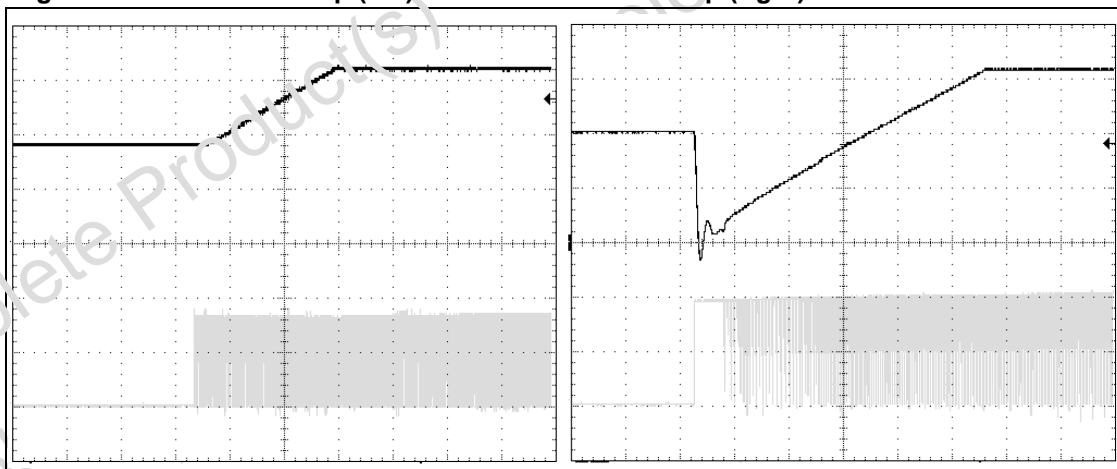

13 Output voltage Monitor and Protections

L6701 monitors through pin VSEN the regulated voltage in order to manage the OVP, UVP and PGOOD (when applicable) conditions. Protections are active also during soft-start (See [Section 12](#) for details) while are masked during D-VID transitions with an additional 32 clock cycle delay after the transition has finished to avoid false triggering.

In addition, preliminary over-voltage protection is also provided to protect the load from high-side MOSFET failures before the system turn-ON.

13.1 Under Voltage

If the output voltage monitored by VSEN drops more than -400mV below the programmed reference for more than one clock period, the device turns off all MOSFETs driving high the FAULT pin and latches the condition: to recover it is required to cycle VCC or the EN pin. This is independent by the selected operative mode.

13.2 Preliminary Over Voltage

To provide a protection while VCC is below the $UVLO_{VCC}$ threshold is fundamental to avoid damage to the load in case of failed HS MOSFETs. In fact, since the device is supplied from the 12V bus, it is basically “blind” for any voltage below the turn-on threshold ($UVLO_{VCC}$). In order to give full protection to the load, a preliminary-OVP protection is provided while VCC is within $UVLO_{VCC}$ and $UVLO_{OVP}$.

According to the DAC_SEL pin status, this protection turns-on the low side MOSFETs as long as the FBR pin voltage is greater than 1.9V for VR10 and 2.1V for VR9 and K8 with a 300mV hysteresis (See [Table 10](#)). When set, the protection drives the LS MOSFET with a gate-to-source voltage depending on the voltage applied to VCC. This protection depends also on the EN pin status as detailed in [Figure 13](#). Preliminary OVP is always active before $UVLO_{VCC}$ for all operative modes with intervention thresholds dependent on the DAC_SEL pin status.

A simple way to provide protection to the output in all conditions when the system is OFF (then avoiding the unprotected red region in [Figure 13-Left](#)) consists in supplying the controller through the 5VSB bus with an OR-ing diode solution as shown in [Figure 13-Right](#): 5VSB is always present before +12V and, in case of HS short, the LS MOSFET is driven with 5V assuring a reliable protection of the load.

When using the OR-ing diode solution, OR-ing diodes need to be sized according to the device current consumption: the two diodes will then results to be different since the diode connected to the 12V bus needs to carry the current for normal operations (I_{RMS}) and the diode connected to the 5V_{SB} ($I_{RMS-PREOVP}$) need to carry only the current in case of Pre-OVP protection is active. Device current consumption (I_{RMS}) in normal operations depends on the external MOSFET configuration as follow:

$$I_{RMS} = 3 \cdot F_{SW} \cdot (Q_{GHS} + Q_{GLS}) + (I_{CC} + 3 \cdot I_{CCDRx} + 3 \cdot I_{BOOTx})$$

Device current consumption when Pre-OVP is active depends on the output filter configuration since LS MOSFETs switching frequency depends on the leakage that is charging the output filter. Test on the bench is required but, for an over-sized solution, the same diode identified for the +12V bus can be used.

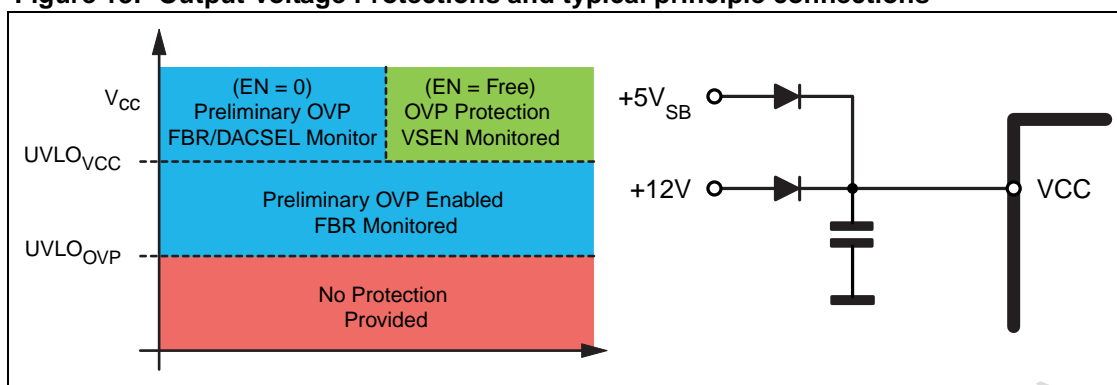
Figure 13. Output Voltage Protections and typical principle connections

13.3 Over Voltage

Once VCC crosses the turn-ON threshold and the device is enabled (EN = Free), L6701 provides an Over Voltage Protection according to the DAC_SEL status. When the voltage sensed by VSEN overcomes the OVP threshold, the controller permanently switches off all the low-side MOSFETs and switches on all the high-side MOSFETs in order to protect the load. The FAULT pin is driven high (5V) and power supply or EN pin cycling is required to restart operations.

The OVP (and Pre-OVP) Threshold varies according to the operative mode selected as reported in [Table 10](#).

Table 10. OVP and Preliminary OVP Thresholds

DAC_SEL	Operative Mode	Pre-OVP	OVP
0	VR9	2.1	2.1
82kΩ to SGND	VR10	1.9	1.9
Cap.	K8	1.9	1.9

13.4 Feedback Disconnection

L6701 allows to monitor the output voltage in two different points:

- Remotely, through the remote buffer, across VSEN
- Locally across the CS- pin (negligibly offset by $R_D \cdot I_{CS}$).

By comparing the voltage present at these two different locations, L6701 is able to understand if the output voltage feedback is connected. When CS- is more than 1V higher than VSEN, (See [Figure 14](#)) the device stops switching with the low side MOSFETs permanently ON and drives high the FAULT pin. The condition is latched until VCC or EN cycled.

Figure 14. Feedback Disconnection

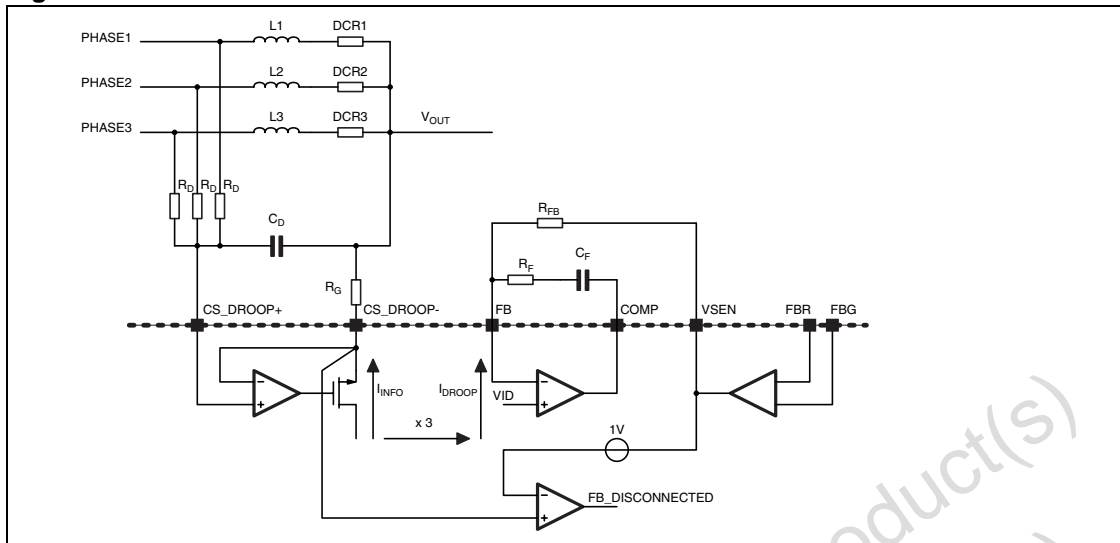

13.5 PGOOD (Only for VR9 and K8 Modes)

It is an open-drain signal set free after the soft-start sequence has finished. It is pulled low when the output voltage drops below -230mV of the programmed voltage.

13.6 Over Current Protection

Output current in each phase is monitored by L6701 through R_{ISEN} and so, programming the value of these resistors, it is possible to set the OCP to the desired value. The Over Current threshold has to be programmed to a safe value, in order to be sure that the device doesn't enter OCP during normal operation of the device. This value must take into consideration also the extra current needed during the Dynamic VID Transition I_{D-VID} and, since the device reads across MOSFETs $R_{DS(on)}$, the process spread and temperature variations of these sensing elements. Moreover, since also the internal threshold spreads, the R_g design has to consider the minimum value $I_{OCTH(min)}$ of the threshold as follow:

$$R_g = \frac{I_{OCPx(max)} \cdot R_{dsON(max)}}{I_{OCTH(min)}}$$

where I_{OCPx} is the current measured by the current reading circuitry when the device enters Quasi-Constant-Current.

Since the device reads the current across Low Side MOSFETs, it limits the bottom of the inductor current entering in constant current until setting UVP as below explained. I_{OCPx} must be calculated starting from the corresponding output current value $I_{OUT(OCP)}$ as follow (I_{D-VID} must also be considered when D-VID are supported) since the device holds the valley current information:

$$I_{OCPx} = \frac{I_{OUT(OCP)}}{3} - \frac{\Delta I_{PP}}{2} + \frac{I_{D-VID}}{3}$$

where $I_{OUT(OCP)}$ is still the output current value at which the device enters Quasi-Constant-Current, I_{PP} is the inductor current ripple in each phase and I_{D-VID} is the additional current required by D-VID (when applicable). In particular, since the device limits the valley of the

inductor current, the ripple entity, when not negligible, impacts on the real OC threshold value and must be considered.

The device detects an Over Current condition for each phase when the current information I_{ISEN_x} overcomes the fixed threshold of I_{OCTH} . When this happens, the device keeps the relative LS MOSFET on, also skipping clock cycles, until the threshold is crossed back and I_{ISEN_x} results being lower than the I_{OCTH} threshold (this implies that the device limits the bottom of each inductor current ripple). After exiting the OC condition, the LS MOSFET is turned off and the HS is turned on with a duty cycle driven by the PWM comparator.

The device enters in Quasi-Constant-Current operation: the low-side MOSFETs stays ON until the current read becomes lower than I_{OCPx} ($I_{INFOx} < I_{OCTH}$) skipping clock cycles. The high side MOSFET can be then turned ON with a T_{ON} imposed by the control loop after the LS turn-off and the device works in the usual way until another OCP event is detected.

This means that the average current delivered can slightly increase in Quasi-Constant Current operation since the current ripple increases. In fact, the ON time increases due to the OFF time rise because of the current has to reach the I_{OCPx} bottom. The worst-case condition is when the ON time reaches its maximum value (see Section 10.5). When this happens, the device works in Real Constant Current and the output voltage decrease as the load increase. Crossing the UVP threshold causes the device to latch driving high the OVC pin.

It can be observed that the peak current (I_{PEAK}) is greater than I_{OCPx} but it can be determined as follow:

$$I_{PEAK} = I_{OCPx} + \frac{V_{IN} - V_{OUT(min)}}{L} \cdot T_{ON(max)} = I_{OCPx} + \frac{V_{IN} - V_{OUT(min)}}{L} \cdot 0.40 \cdot T_{SW}$$

Where V_{outMIN} is the UVP threshold, (inductor saturation must be considered). When that threshold is crossed, all MOSFETs are turned off, the FAULT pin is driven high and the device stops working. Cycle the power supply or the EN pin to restart operation.

The maximum average current during the Constant-Current behavior results (see Figure 15):

$$I_{MAX,tot} = 3 \cdot I_{MAX} = 3 \cdot \left(I_{OCPx} + \frac{I_{PEAK} - I_{OCPx}}{2} \right)$$

in this particular situation, the switching frequency for each phase results reduced. The ON time is the maximum allowed $T_{ON(max)}$ while the OFF time depends on the application:

$$T_{OFF} = L \cdot \frac{I_{PEAK} - I_{OCPx}}{V_{OUT}} \quad f = \frac{1}{T_{ON(max)} + T_{OFF}}$$

Figure 15. Constant Current Operation

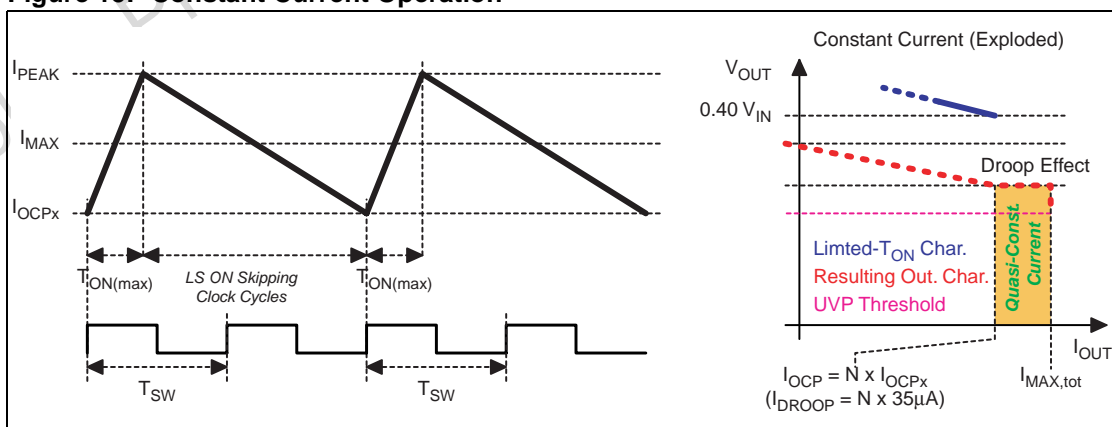

The trans-conductance resistor R_{ISEN_x} can be designed considering that the device limits the bottom of the inductor current ripple and also considering the additional current delivered during the quasi-constant-current behavior as previously described in the worst case conditions.

Moreover, when designing D-VID compatible systems, the additional current due to the output filter charge during dynamic VID transitions must be considered.

$$R_{ISEN_x} = \frac{I_{OCPx(max)} \cdot R_{dsON(max)}}{I_{OCTH(min)}} \text{ where } I_{OCPx} = \frac{I_{OUT(OCP)}}{3} - \frac{\Delta I_{PP}}{2} + \frac{I_{D-VID}}{3}$$

Obsolete Product(s) - Obsolete Product(s)
 Obsolete Product(s) - Obsolete Product(s)

14 Oscillator

The internal oscillator generates the triangular waveform for the PWM charging and discharging with a constant current an internal capacitor. The switching frequency for each channel, F_{SW} , is internally fixed at 100kHz so that the resulting switching frequency at the load side results in being tripled (300kHz).

The current delivered to the oscillator is typically 25µA (corresponding to the free-running frequency $F_{SW}=100kHz$) and it may be varied using an external resistor (R_{OSC}) connected between the OSC pin and SGND. Since the OSC pin is fixed at 1.24V, the frequency is increased proportionally to the current sunk from the pin considering the internal gain of 4KHz/µA.

In particular connecting R_{OSC} to SGND the frequency is increased according to the following relationship:

$$R_{OSC} \text{ vs. SGND } F_{SW} = 100kHz + \frac{1.240V}{R_{OSC}(k\Omega)} \cdot 4 \frac{kHz}{\mu A} = 100kHz + \frac{4.96 \cdot 10^6}{R_{OSC}(k\Omega)}$$

Caution: Maximum programmable switching frequency per phase must be limited to 500kHz to avoid current reading errors causing, as a consequence, current sharing errors. Anyway, device power dissipation must be checked prior to design high switching frequency systems.

Figure 16. R_{OSC} vs. Switching Frequency

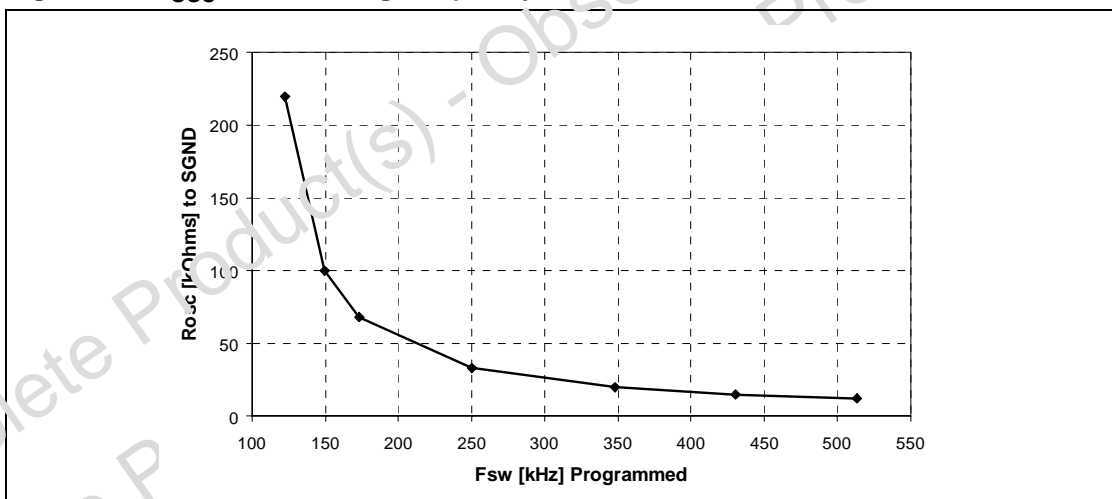

15 System Control Loop Compensation

The control loop is composed by the Current Sharing control loop (See [Figure 17](#)) and the Average Current Mode control loop. Each loop gives, with a proper gain, the correction to the PWM in order to minimize the error in its regulation: the Current Sharing control loop equalize the currents in the inductors while the Average Current Mode control loop fixes the output voltage equal to the reference programmed by VID. [Figure 17](#) shows the block diagram of the system control loop.

The system Control Loop is reported in [Figure 18](#). The current information I_{DROOP} sourced by the DROOP pin flows into R_{FB} implementing the dependence of the output voltage from the read current.

Figure 17. Main Control Loop

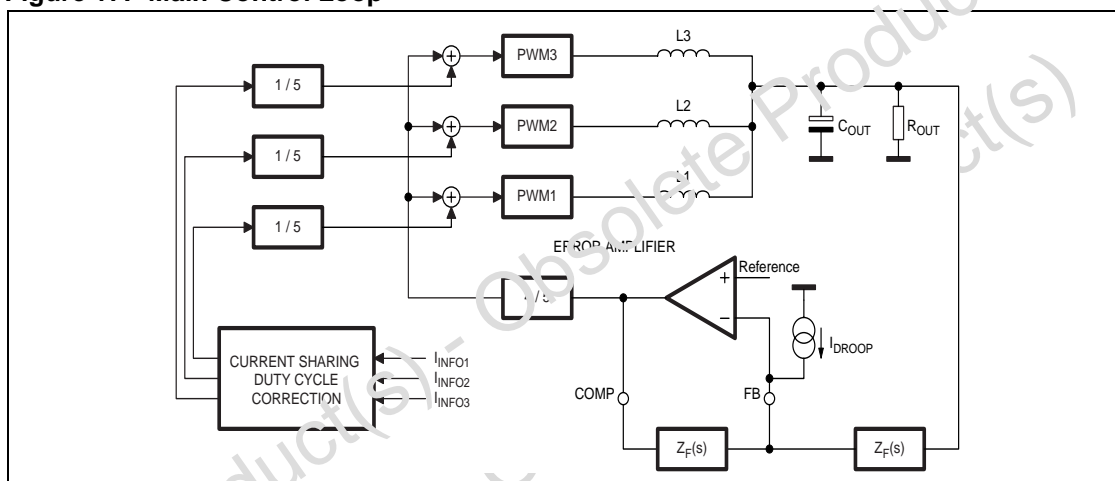

The system can be modeled with an equivalent single phase converter which only difference is the equivalent inductor $L/3$ (where each phase has an L inductor). The Control Loop gain results (obtained opening the loop after the COMP pin):

$$G_{LOOP}(s) = \frac{PWM \cdot Z_F(s) \cdot (R_{DROOP} + Z_P(s))}{[Z_P(s) + Z_L(s)] \cdot \left[\frac{Z_F(s)}{A(s)} + \left(1 + \frac{1}{A(s)} \right) \cdot R_{FB} \right]}$$

Where:

- $R_{DROOP} = \frac{DCR}{R_D} \cdot R_{FB}$ is the equivalent output resistance determined by the droop function
($R_{DROOP} = 3 \cdot \frac{DCR}{R_D} \cdot R_{FB}$ for fully differential current sense);
- $Z_P(s)$ is the impedance resulting by the parallel of the output capacitor (and its ESR) and the applied load R_O ;
- $Z_F(s)$ is the compensation network impedance;
- $Z_L(s)$ is the parallel of the three inductor impedance;
- $A(s)$ is the error amplifier gain;

- $PWM = \frac{4}{5} \cdot \frac{V_{IN}}{\Delta V_{OSC}}$ is the PWM transfer function where ΔV_{OSC} is the oscillator ramp amplitude and has a typical value of 3V.

Removing the dependence from the Error Amplifier gain, so assuming this gain high enough, and with further simplifications, the control loop gain results:

$$G_{LOOP}(s) = \frac{4}{5} \cdot \frac{V_{IN}}{\Delta V_{OSC}} \cdot \frac{Z_F(s)}{R_{FB}} \cdot \frac{R_O + R_{DROOP}}{R_O + \frac{R_L}{3}} \cdot \frac{1 + s \cdot C_O \cdot (R_{DROOP} // R_O + ESR)}{s^2 \cdot C_O \cdot \frac{L}{3} + s \cdot \left[\frac{L}{3 \cdot R_O} + C_O \cdot ESR + C_O \cdot \frac{R_L}{3} \right] + 1}$$

The system Control Loop gain (See [Figure 18](#)) is designed in order to obtain a high DC gain to minimize static error and to cross the 0dB axes with a constant -20dB/dec slope with the desired crossover frequency ω_T . Neglecting the effect of $Z_F(s)$, the transfer function has one zero and two poles; both the poles are fixed once the output filter is designed (LC filter resonance ω_{LC}) and the zero (ω_{ESR}) is fixed by ESR and the Droop resistance.

Figure 18. Equivalent Control Loop Block Diagram (left) and Bode Diagram (right).

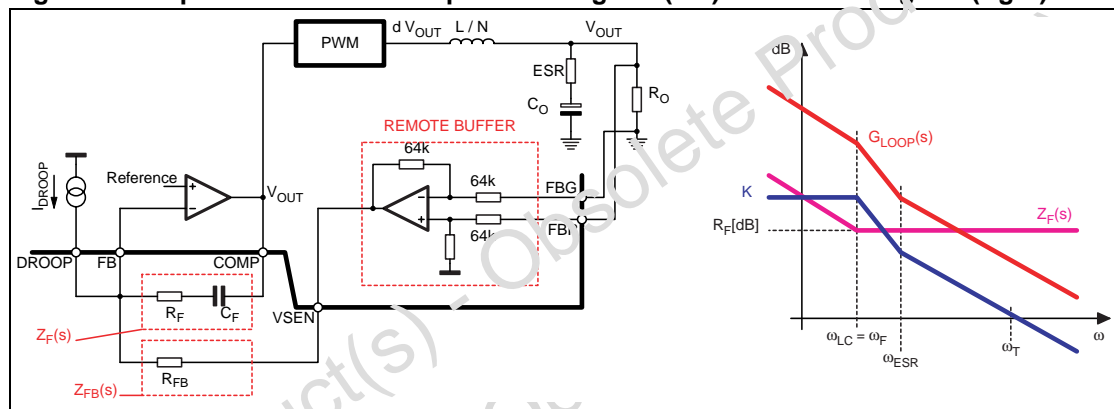

To obtain the desired shape an $R_F - C_F$ series network is considered for the $Z_F(s)$ implementation. A zero at $\omega_F = 1/R_F C_F$ is then introduced together with an integrator. This integrator minimizes the static error while placing the zero ω_F in correspondence with the L-C resonance assures a simple -20dB/dec shape of the gain.

In fact, considering the usual value for the output filter, the LC resonance results to be at frequency lower than the above reported zero.

Compensation network can be simply designed placing $\omega_F = \omega_{LC}$ and imposing the cross-over frequency ω_T as desired obtaining (always considering that ω_T might be not higher than 1/10th of the switching frequency F_{SW}):

$$R_F = \frac{R_{FB} \cdot \Delta V_{OSC}}{V_{IN}} \cdot \frac{5}{4} \cdot \omega_T \cdot \frac{L}{3 \cdot (R_{DROOP} + ESR)} \quad C_F = \frac{\sqrt{C_O \cdot \frac{L}{3}}}{R_F}$$

15.1 Compensation Network Guidelines

The Compensation Network design assures to having system response according to the cross-over frequency selected and to the output filter considered: it is anyway possible to further fine-tune the compensation network modifying the bandwidth in order to get the best response of the system as follow (See [Figure 19](#)):

- Increase R_F to increase the system bandwidth accordingly;
- Decrease R_F to decrease the system bandwidth accordingly;
- Increase C_F to move ω_F to low frequencies increasing as a consequence the system phase margin.

Having the fastest compensation network gives not the confidence to satisfy the requirements of the load: the inductor still limits the maximum dI/dt that the system can afford. In fact, when a load transient is applied, the best that the controller can do is to “saturate” the duty cycle to its maximum (d_{MAX}) or minimum (0) value. The output voltage dV/dt is then limited by the inductor charge / discharge time and by the output capacitance. In particular, the most limiting transition corresponds to the load removal since the inductor results being discharged only by V_{OUT} (while it is charged by $d_{MAX}V_{IN}-V_{OUT}$ during a load appliance).

Referring to [Figure 19](#)-left, further tuning the Compensation network cannot give any improvements unless the output filter changes: only modifying the main inductors or the output capacitance improves the system response.

Figure 19. Best Load Transient achievable (C_F) and R_F - C_F impact on Bandwidth.

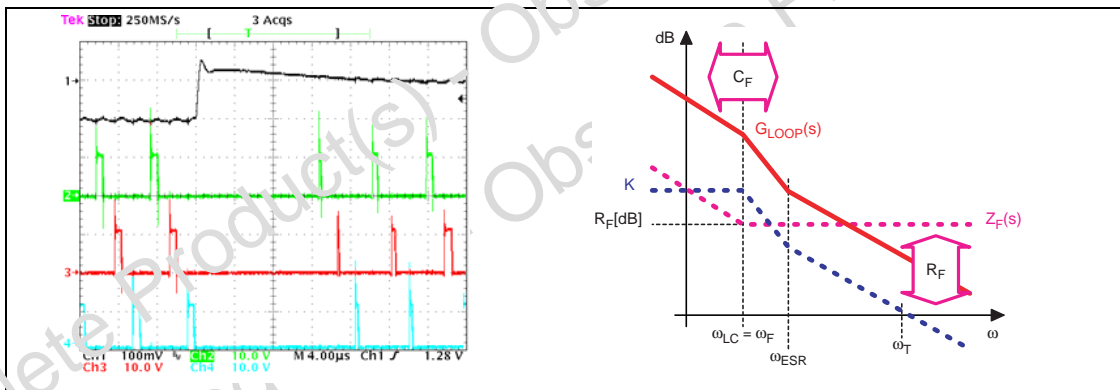

16 Layout Guidelines

Since the device manages control functions and high-current drivers, layout is one of the most important things to consider when designing such high current applications. A good layout solution can generate a benefit in lowering power-dissipation on the power paths, reducing radiation and a proper connection between signal and power ground can optimize the performance of the control loops.

Two kind of critical components and connections have to be considered when laying out a VRM based on L6701: power components and connections and small signal components connections.

16.1 Power Components and Connections

These are the components and connections where switching and high continuous current flows from the input to the load. The first priority when placing components has to be reserved to this power section, minimizing the length of each connection and loops as much as possible. To minimize noise and voltage spikes (EMI and losses) these interconnections must be a part of a power plane and anyway realized by wide and thick copper traces: loop must be anyway minimized. The critical components, i.e. the power transistors, must be close one to the other. The use of multi-layer printed circuit board is recommended.

Figure 20 shows the details of the power connections involved and the current loops. The input capacitance (C_{IN}), or at least a portion of the total capacitance needed, has to be placed close to the power section in order to eliminate the stray inductance generated by the copper traces. Low ESR and ESL capacitors are preferred, MLCC are suggested to be connected near the HS drain.

Use proper VIAs number when power traces have to move between different planes on the PCB in order to reduce both parasitic resistance and inductance. Moreover, reproducing the same high-current trace on more than one PCB layer will reduce the parasitic resistance associated to that connection.

Connect output bulk capacitor as near as possible to the load, minimizing parasitic inductance and resistance associated to the copper trace also adding extra decoupling capacitors along the way to the load when this results in being far from the bulk capacitor bank.

Gate traces must be sized according to the driver RMS current delivered to the power MOSFET. The device robustness allows managing applications with the power section far from the controller without losing performances. Anyway, when possible, it is suggested to minimize the distance between controller and power section.

16.2 Small Signal Components and Connections

These are small signal components and connections to critical nodes of the application as well as bypass capacitors for the device supply (See [Figure 20](#)). Locate the bypass capacitor (VCC and Bootstrap capacitor) close to the device and refer sensible components such as frequency set-up resistor R_{OSC} to SGND. Star grounding is suggested: connect SGND to PGND plane in a single point to avoid that drops due to the high current delivered causes errors in the device behavior.

VSEN pin filtered vs. SGND helps in reducing noise injection into device: take care in routing driving net for this pin in order to minimize coupled noise.

Remote Buffer Connection must be routed as parallel nets from the FBG/FBR pins to the load in order to avoid the pick-up of any common mode noise. Connecting these pins in points far from the load will cause a non-optimum load regulation, increasing output tolerance.

Locate current reading components close to the device. It's also important to minimize any offset in the measurement and, to get a better precision, to connect the traces as close as possible to the sensing elements.

Caution: Boot Capacitor Extra Charge. Systems that do not use Schottky diodes might show big negative spikes on the phase pin. This spike can be limited as well as the positive spike but has an additional consequence: it causes the bootstrap capacitor to be over-charged. This extra-charge can cause, in the worst case condition of maximum input voltage and during particular transients, that boot-to-phase voltage overcomes the abs. max. ratings also causing device failures. It is then suggested in this cases to limit this extra-charge by:

- adding a small resistor in series to the boot diode (one resistor can be enough for all the three diodes if placed upstream the boot diode anode, see [Figure 20](#))
- using non-capacitive boot diodes (such as standard diodes).

Figure 20. Power connections and related connections layout (same for all phases).

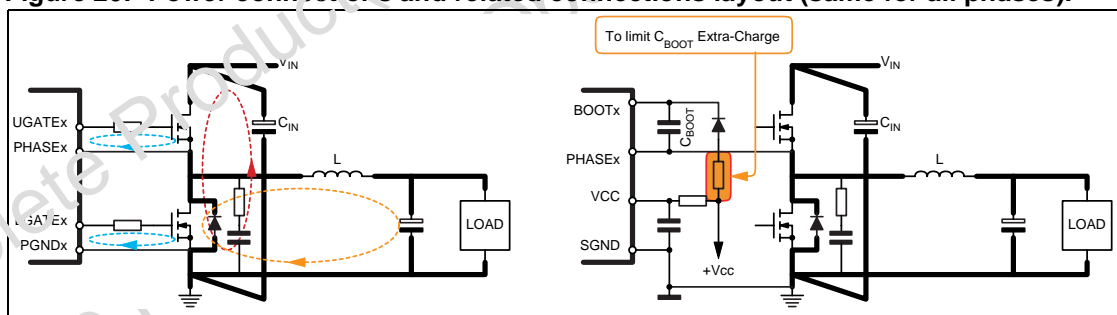

16.3 Embedding L6701-based VRs

When embedding the VR into the application, additional care must be taken since the whole VR is a switching DC/DC regulator and the most common systems in which it has to work are digital systems such as MB or similar. In fact, latest MB has become faster and powerful: high speed data bus are more and more common and switching-induced noise produced by the VR' MOSFETs can affect data integrity if not following additional layout guidelines. Few easy points must be considered mainly when routing traces and planes in which high switching currents flow (high switching currents cause voltage spikes across the stray inductance of the trace causing noise that can affect the near traces):

Keep safe guarding distance between high current switching VRD traces and data buses, especially if high-speed data bus to minimize noise coupling.

Keep safe guard distance or filter properly when routing bias traces for I/O sub-systems that must walk near the VRD.

Possible causes of noise can be located in the PHASE connections, MOSFET gate drive and Input voltage path (from input bulk capacitors and HS drain). Also PGND connections must be considered if not insisting on a power ground plane. These connections must be carefully kept far away from noise-sensitive data bus.

Since the generated noise is mainly due to the switching activity of the VR, noise emissions depend on how fast the current switches. To reduce noise emission levels, it is also possible, in addition to the previous guidelines, to reduce the current slope by properly tuning the HS gate resistor and the PHASE snubber network.

17 Package Mechanical Data

In order to meet environmental requirements, ST offers these devices in ECOPACK® packages. These packages have a Lead-free second level interconnect . The category of second Level Interconnect is marked on the package and on the inner box label, in compliance with JEDEC Standard JESD97. The maximum ratings related to soldering conditions are also marked on the inner box label. ECOPACK is an ST trademark. ECOPACK specifications are available at: www.st.com.

Obsolete Product(s) - Obsolete Product(s)
Obsolete Product(s) - Obsolete Product(s)

PowerSSO-36 Mechanical Data

Dim.	mm			inch		
	Min.	Typ.	Max.	Min.	Typ.	Max.
A	2.15		2.47	0.084		0.097
A2	2.15		2.40	0.084		0.094
a1	0		0.075	0		0.003
b	0.18		0.36	0.007		0.014
c	0.23		0.32	0.009		0.012
D ⁽¹⁾	10.10		10.50	0.398		0.413
E ⁽²⁾	7.4		7.6	0.291		0.299
e		0.50			0.020	
e3		8.50			0.035	
F		2.3			0.090	
G			0.10			0.004
G1			0.06			0.002
H	10.10		10.50	0.398		0.413
h			0.40			0.016
L	0.55		0.85	0.022		0.033
M		4.3			0.169	
N	10° (max)					
O		1.2			0.047	
Q		0.8			0.031	
S		2.9			0.114	
I		3.65			0.144	
U		1.0			0.039	
X	4.10		4.70	0.161		0.185
Y	6.50		7.10	0.256		0.279

1. "D and E" do not include mold flash or protusions. Mold flash or protusions shall not exceed 0.15mm (0.006")
2. No intrusion allowed inwards the leads.
3. Flash or bleeds on exposed die pad shall not exceed 0.4 mm per side

Figure 21. Package Dimensions

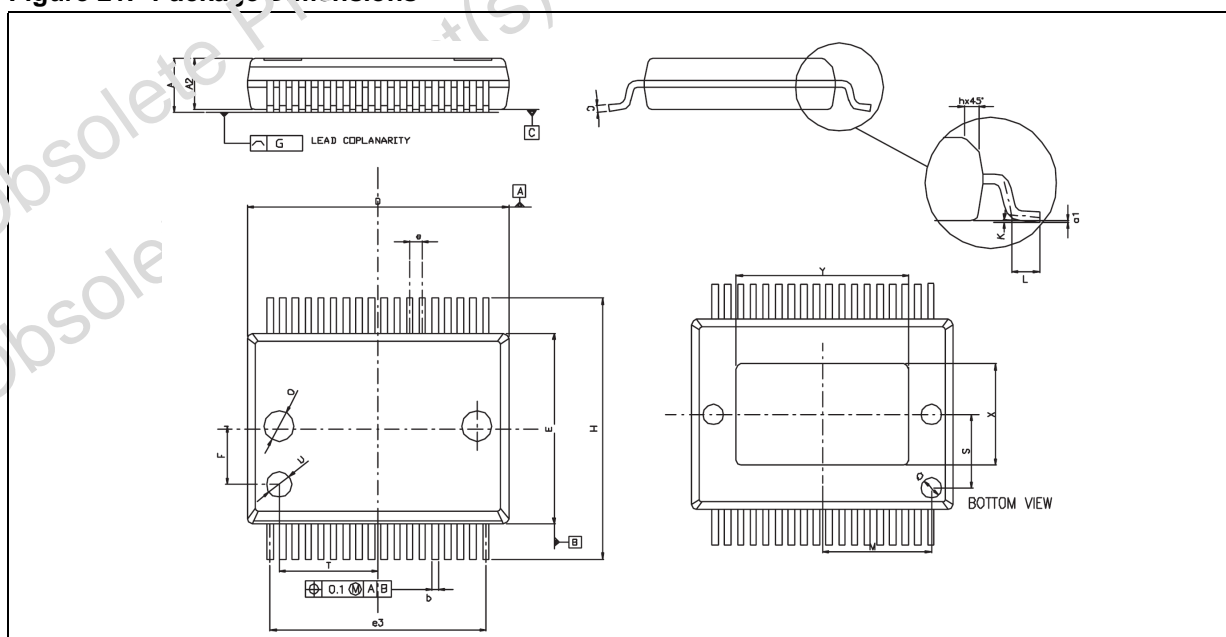

18 Revision history

Date	Revision	Description of Changes
13-Dec-2005	1	First draft

Obsolete Product(s) - Obsolete Product(s)
Obsolete Product(s) - Obsolete Product(s)

Information furnished is believed to be accurate and reliable. However, STMicroelectronics assumes no responsibility for the consequences of use of such information nor for any infringement of patents or other rights of third parties which may result from its use. No license is granted by implication or otherwise under any patent or patent rights of STMicroelectronics. Specifications mentioned in this publication are subject to change without notice. This publication supersedes and replaces all information previously supplied. STMicroelectronics products are not authorized for use as critical components in life support devices or systems without express written approval of STMicroelectronics.

The ST logo is a registered trademark of STMicroelectronics.
All other names are the property of their respective owners

© 2005 STMicroelectronics - All rights reserved



STMicroelectronics group of companies

Australia - Belgium - Brazil - Canada - China - Czech Republic - Finland - France - Germany - Hong Kong - India - Israel - Italy - Japan - Malaysia - Malta - Morocco - Singapore - Spain - Sweden - Switzerland - United Kingdom - United States of America





www.st.com

Looking for pricing, stock, or lifecycle information?

Click below to explore more details on WIN SOURCE:

-  [View L6701TR on WIN SOURCE](#)
-  [STMicroelectronics](#) Information

Optimize Your Supply Chain with WIN SOURCE Solutions

-  Global Sourcing Solution
-  Obsolete Management
-  Cost Control Management
-  Shortage Management
-  Alternative Solution
-  Excess Inventory Management