



**THE DATASHEET OF  
LQW2UASR75G00L**



## CHIP COIL (CHIP INDUCTORS) LQW2UAS□□□□00L REFERENCE SPECIFICATION

### 1.Scope

This reference specification applies to LQW2UAS\_00 Series Chip coil(Chip Inductors).

### 2.Part Numbering

(ex)	LQ	W	2U	A	S	12N	G	0	0	L
	Product ID	Structure	Dimension (L×W)	Applications and Characteristics	Category	Inductance	Tolerance	Features	Electrode	Packaging L:Taping *B:Bulk

\*Bulk packing also available. (A product is put in the plastic bag under the taping conditions.)

### 3.Rating

- Operating Temperature Range.      −55°C ~ +125°C
- Storage Temperature Range.       −55°C ~ +125°C

Customer Part Number	MURATA Part Number	Inductance		Q (min.)	DC Resistance (Ω max.)	Self Resonant Frequency (MHz min.)	Rated Current (mA)
		(nH)	Tolerance				
	LQW2UAS12NG00L	12	G : ±2%	50	0.09	3300	1000
	LQW2UAS12NJ00L						
	LQW2UAS18NG00L	18	J : ±5%	50	0.11	2500	1000
	LQW2UAS18NJ00L						
	LQW2UAS22NF00L	22	F : ±1%	55	0.12	2400	1000
	LQW2UAS22NG00L						
	LQW2UAS22NJ00L						
	LQW2UAS27NG00L	27	G : ±2%	55	0.13	1600	1000
	LQW2UAS27NJ00L						
	LQW2UAS33NF00L	33	F : ±1%	60	0.14	1600	1000
	LQW2UAS33NG00L						
	LQW2UAS33NJ00L						
	LQW2UAS39NF00L	39	G : ±2%	60	0.15	1500	1000
	LQW2UAS39NG00L						
	LQW2UAS39NJ00L						
	LQW2UAS47NF00L	47	J : ±5%	65	0.16	1500	1000
	LQW2UAS47NG00L						
	LQW2UAS47NJ00L						
	LQW2UAS56NF00L	56	F : ±1%	65	0.18	1300	1000
	LQW2UAS56NG00L						
	LQW2UAS56NJ00L						
	LQW2UAS68NF00L	68	G : ±2%	65	0.20	1300	1000
	LQW2UAS68NG00L						
	LQW2UAS68NJ00L						
	LQW2UAS82NF00L	82	J : ±5%	60	0.22	1000	1000
	LQW2UAS82NG00L						
	LQW2UAS82NJ00L						
	LQW2UASR10F00L	100	F : ±1%	60	0.56	1000	650
	LQW2UASR10G00L						
	LQW2UASR10J00L						
	LQW2UASR12F00L	120	G : ±2%	60	0.63	950	650
	LQW2UASR12G00L						
	LQW2UASR12J00L						
	LQW2UASR15F00L	150	J : ±5%	45	0.70	850	580
	LQW2UASR15G00L						
	LQW2UASR15J00L						

Customer Part Number	MURATA Part Number	Inductance		Q (min.)	DC Resistance ( $\Omega$ max.)	Self Resonant Frequency (MHz min.)	Rated Current (mA)
		(nH)	Tolerance				
	LQW2UASR18F00L	180		45	0.77	750	620
	LQW2UASR18G00L						
	LQW2UASR18J00L						
	LQW2UASR22F00L	220		45	0.84	700	500
	LQW2UASR22G00L						
	LQW2UASR22J00L						
	LQW2UASR27F00L	270		45	0.91	600	500
	LQW2UASR27G00L						
	LQW2UASR27J00L						
	LQW2UASR33F00L	330		45	1.05	570	450
	LQW2UASR33G00L						
	LQW2UASR33J00L						
	LQW2UASR39F00L	390		45	1.12	500	470
	LQW2UASR39G00L						
	LQW2UASR39J00L						
	LQW2UASR47F00L	470		45	1.19	450	470
	LQW2UASR47G00L						
	LQW2UASR47J00L						
	LQW2UASR56F00L	560	F : $\pm 1\%$ G : $\pm 2\%$ J : $\pm 5\%$	45	1.33	415	400
	LQW2UASR56G00L						
	LQW2UASR56J00L						
	LQW2UASR62F00L	620		45	1.40	375	300
	LQW2UASR62G00L						
	LQW2UASR62J00L						
	LQW2UASR68F00L	680		45	1.47	375	400
	LQW2UASR68G00L						
	LQW2UASR68J00L						
	LQW2UASR75F00L	750		45	1.54	360	360
	LQW2UASR75G00L						
	LQW2UASR75J00L						
	LQW2UASR82F00L	820		45	1.61	350	400
	LQW2UASR82G00L						
	LQW2UASR82J00L						
	LQW2UASR91F00L	910		35	1.68	320	380
	LQW2UASR91G00L						
	LQW2UASR91J00L						
	LQW2UAS1R0F00L	1000		35	1.75	290	370
	LQW2UAS1R0G00L						
	LQW2UAS1R0J00L						
	LQW2UAS1R2J00L	1200	J : $\pm 5\%$	35	2.0	210	310
	LQW2UAS1R5J00L	1500		28	2.3	120	330
	LQW2UAS1R8J00L	1800		28	2.6	140	300
	LQW2UAS2R2J00L	2200		28	2.8	130	280
	LQW2UAS2R7J00L	2700		22	3.2	110	290
	LQW2UAS3R3J00L	3300		22	3.4	90	290
	LQW2UAS3R9J00L	3900		20	3.6	70	260
	LQW2UAS4R7J00L	4700		20	4.0	60	260

#### 4. Testing Conditions

《Unless otherwise specified》

Temperature : Ordinary Temperature / 15°C to 35°C  
Humidity : Ordinary Humidity / 25%(RH) to 85%(RH)

《In case of doubt》

Temperature : 20°C $\pm$ 2°C  
Humidity : 60%(RH) to 70%(RH)  
Atmospheric Pressure : 86kPa to 106 kPa

5. Appearance and Dimensions

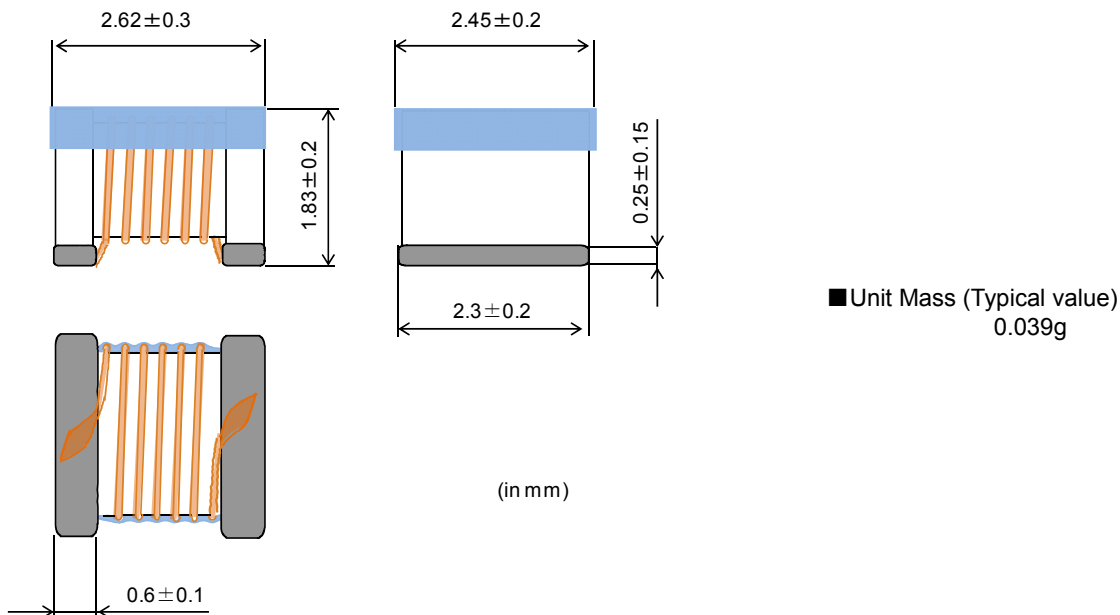

6. Electrical Performance

No.	Item	Specification	Test Method
6.1	Inductance	Inductance shall meet item 3.	Measuring Equipment: KEYSIGHT 4287A or equivalent Measuring Frequency: <Inductance> 50MHz/12nH~82nH 25MHz/100nH~1000nH 7.9MHz/1200nH~4700nH <Q> 500MHz/12nH~15nH 350MHz/18nH~120nH 100MHz/150nH~820nH 50MHz/910nH~2200nH 25MHz/2700nH~4700nH Measuring Condition: Test signal level / about 0dBm Electrode spaces / 1.5mm Electrical length / 10.0mm Weight / about 1N~3N Measuring Fixture: KEYSIGHT 16197A Position coil under test as shown in below and contact coil with each terminal by adding weight.
6.2	Q	Q shall meet item 3.	
6.3	DC Resistance	DC Resistance shall meet item 3.	Measuring Equipment: Digital multi meter
6.4	Self Resonant Frequency(SRF)	S.R.F shall meet item 3.	Measuring Equipment: KEYSIGHT 8753C or equivalent
6.5	Rated Current	Self temperature rise shall be limited to 40°C max.	The rated current is applied.

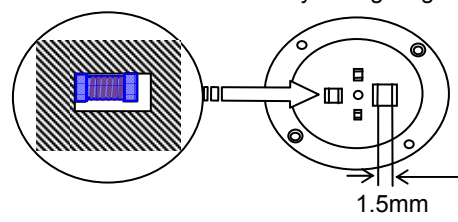

## 7.Mechanical Performance

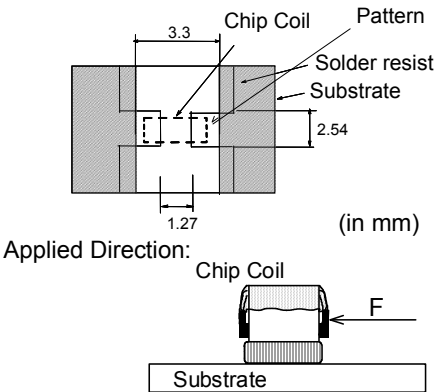
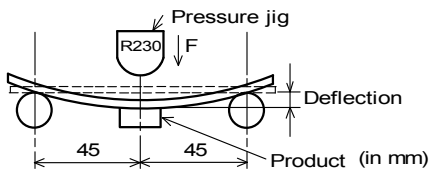
No.	Item	Specification	Test Method
7.1	Shear Test	Chip coil shall not be damaged after tested as test meth	Substrate:Glass-epoxy substrate  Applied Direction: Force:10N Hold Duration:5s±1s
7.2	Bending Test	Chip coil shall not be damaged after tested as test method.	Substrate:Glass-epoxy substrate (100mm × 40mm × 1.0mm) Speed of Applying Force:1mm / s Deflection:3mm Hold Duration:5s 
7.3	Vibration	Chip coil shall not be damaged after tested as test method	Oscillation Frequency: 10Hz~2000Hz~10Hz for 15 min Total amplitude 3 mm or Acceleration amplitude 196m/s <sup>2</sup> whichever is smaller. Time : A period of 2 hours in each of 3 mutually perpendicular directions. (Total 6hours)
7.4	Solderability	The wetting area of the electrode shall be at least 90% covered with new solder coating.	Flux:Ethanol solution of rosin,25(wt)% Includes activator equivalent to 0.06(wt)% chlorine.(immersed for 5s to 10s) Solder:Sn-3.0Ag-0.5Cu Pre-Heating:150°C±10°C / 60s to 90s Solder Temperature:240°C±5°C Immersion Time:3s±1s
7.5	Resistance to Soldering Heat	Appearance:No damage Inductance Change: within ±5%	Flux:Ethanol solution of rosin,25(wt)% Includes activator equivalent to 0.06(wt)% Chlorine.(immersed for 5s to 10s) Solder:Sn-3.0Ag-0.5Cu Pre-Heating:150°C±10°C / 60s to 90s Solder Temperature:270°C±5°C Immersion Time:10s±1s Then measured after exposure in the room condition for 24h±2h.

### 8.Environmental Performance

It shall be soldered on the substrate.

No.	Item	Specification	Test Method
8.1	Heat Resistance	Appearance:No damage Inductance Change: within $\pm 5\%$ Q Change: within $\pm 20\%$	Temperature: $125^{\circ}\text{C}\pm 2^{\circ}\text{C}$ Time:1000h (+48h,0h) Then measured after exposure in the room condition for 24h $\pm 2$ h.
8.2	Cold Resistance		Temperature: $-55^{\circ}\text{C}\pm 2^{\circ}\text{C}$ Time:1000h (+48h,-0h) Then measured after exposure in the room condition for 24 $\pm 2$ h.
8.3	Humidity		Temperature: $85^{\circ}\text{C}\pm 2^{\circ}\text{C}$ Humidity:85%(RH) Time:1000h (+48h,-0h) Then measured after exposure in the room condition for 24h $\pm 2$ h.
8.4	Temperature Cycle		1 cycle: 1 step: $-55^{\circ}\text{C}\pm 2^{\circ}\text{C}$ / 30min $\pm 3$ min 2 step:Ordinary temp. / 10min to 15 min 3 step: $+125^{\circ}\text{C}\pm 2^{\circ}\text{C}$ / 30min $\pm 3$ min 4 step:Ordinary temp. / 30min $\pm 3$ min Total of 10 cycles Then measured after exposure in the room condition for 24h $\pm 2$ h.

### 9.Specification of Packaging

#### 9.1 Appearance and Dimensions of plastic tape (8mm-wide, 4mm-pitch)

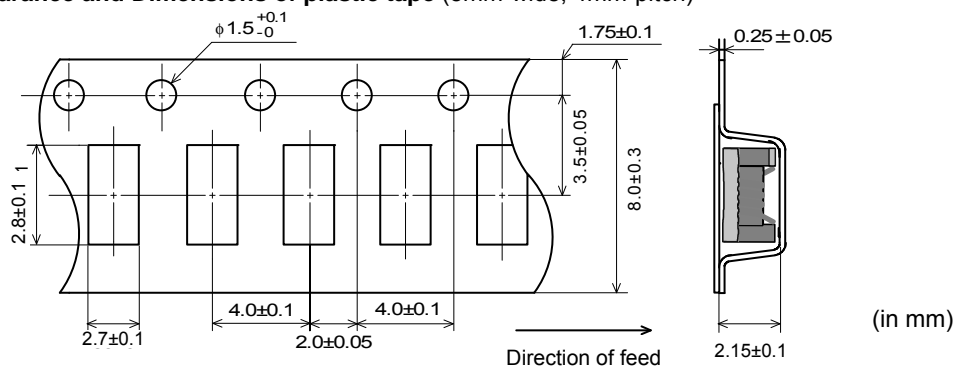

•Dimension of the Cavity is measured at the bottom side.

#### 9.2 Specification of Taping

- (1) Packing quantity (standard quantity)  
2,000 pcs. / reel
- (2) Packing Method  
Products shall be packed in the cavity of the plastic tape and sealed by Cover tape.
- (3) Sprocket hole  
The sprocket holes are to the right as the tape is pulled toward the user.
- (4) Spliced point  
Plastic tape and Cover tape has no spliced point.
- (5) Missing components number  
Missing components number within 0.1% of the number per reel or 1 pc., whichever is greater, and are not continuous. The Specified quantity per reel is kept.

#### 9.3 Pull Strength

Plastic tape	5N min.
Cover tape	10N min.

### 9.4 Peeling off force of cover tape

Speed of Peeling off	300mm/min
Peeling off force	0.1N to 0.6N (minimum value is typical)

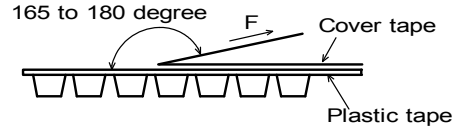

### 9.5 Dimensions of Leader-tape, Trailer and Reel

There shall be leader-tape ( cover tape and empty tape) and trailer-tape (empty tape) as follows.

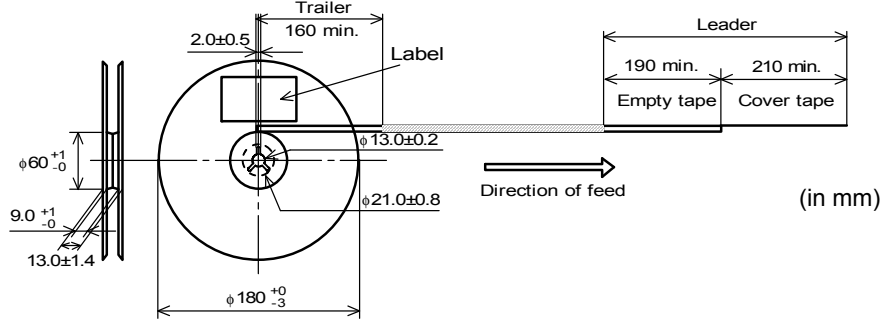

### 9.6 Marking for reel

Customer part number, MURATA part number, Inspection number(\*1) , RoHS Marking (\*2), Quantity etc ...

\*1) <Expression of Inspection No.>

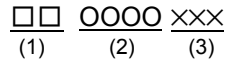

(1) Factory Code

(2) Date First digit : Year / Last digit of year

Second digit : Month / Jan. to Sep. → 1 to 9, Oct. to Dec. → O,N,D

Third, Fourth digit : Day

(3) Serial No.

\*2) <Expression of RoHS Marking >

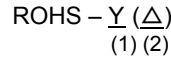

(1) RoHS regulation conformity parts.

(2) MURATA classification number

### 9.7 Marking for Outside package (corrugated paper box)

Customer name, Purchasing order number, Customer part number, MURATA part number, RoHS Marking (\*2) ,Quantity, etc ...

### 9.8. Specification of Outer Case

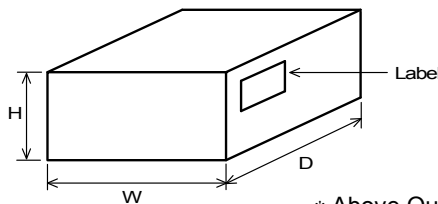

Outer Case Dimensions (mm)			Standard Reel Quantity in Outer Case (Reel)
W	D	H	
186	186	93	5

\* Above Outer Case size is typical. It depends on a quantity of an order.

## 10. ⚠ Caution

### Limitation of Applications

Please contact us before using our products for the applications listed below which require especially high reliability for the prevention of defects which might directly cause damage to the third party's life, body or property.

- (1) Aircraft equipment
- (2) Aerospace equipment
- (3) Undersea equipment
- (4) Power plant control equipment
- (5) Medical equipment
- (6) Transportation equipment (vehicles, trains, ships, etc.)
- (7) Traffic signal equipment
- (8) Disaster prevention / crime prevention equipment
- (9) Data-processing equipment
- (10) Applications of similar complexity and /or reliability requirements to the applications listed in the above

**11. Notice**

Products can only be soldered with reflow.  
 This product is designed for solder mounting.  
 Please consult us in advance for applying other mounting method such as conductive adhesive.

**11.1 Land pattern designing**

Recommended land patterns for reflow soldering are as follows:  
 These have been designed for Electric characteristics and solderability.  
 Please follow the recommended patterns. Otherwise, their performance which includes electrical performance or solderability may be affected, or result to "position shift" in soldering process

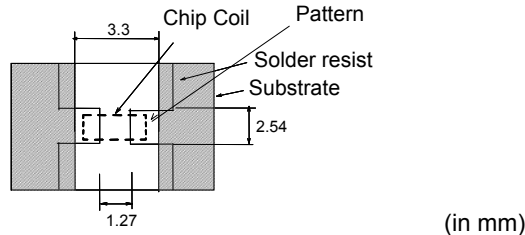

- Do not use gilded pattern. A copper wire may cause open by dissolution of metallization.

**11.2 Flux, Solder**

- Use rosin-based flux.  
 Includes middle activator equivalent to 0.06(wt)% to 0.1(wt)% Chlorine.  
 Don't use highly acidic flux with halide content exceeding 0.2(wt)% (chlorine conversion value).  
 Don't use water-soluble flux.
- Use Sn-3.0Ag-0.5Cu solder.
- Standard thickness of solder paste : 100 μm to 150 μm.

**11.3 Reflow soldering conditions**

- Pre-heating should be in such a way that the temperature difference between solder and product surface is limited to 150°C max. Cooling into solvent after soldering also should be in such a way that the temperature difference is limited to 100°C max.  
 Insufficient pre-heating may cause cracks on the product, resulting in the deterioration of products quality.

- Standard soldering profile and the limit soldering profile is as follows.  
 The excessive limit soldering conditions may cause leaching of the electrode and / or resulting in the deterioration of product quality.

- Reflow soldering profile

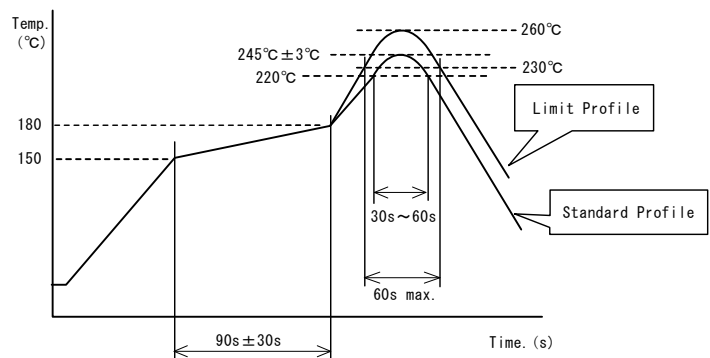

	Standard Profile	Limit Profile
Pre-heating	150°C ~ 180°C , 90s ± 30s	
Heating	above 220°C, 30s ~ 60s	above 230°C, 60s max.
Peak temperature	245°C ± 3°C	260°C, 10s
Cycle of reflow	2 times	

### 11.4 Reworking with soldering iron.

The following conditions must be strictly followed when using a soldering iron.

Pre-heating	150°C, 1 min
Tip temperature	350°C max.
Soldering iron output	80W max.
Tip diameter	Φ · 3mm max.
Soldering time	3(+1,-0)s
Times	2 times

Note : Do not directly touch the products with the tip of the soldering iron in order to prevent the crack on the products due to the thermal shock.

### 11.5 Solder Volume

- Solder shall be used not to be exceeded the upper limits as shown below.
- Accordingly increasing the solder volume, the mechanical stress to Chip is also increased. Exceeding solder volume may cause the failure of mechanical or electrical performance.

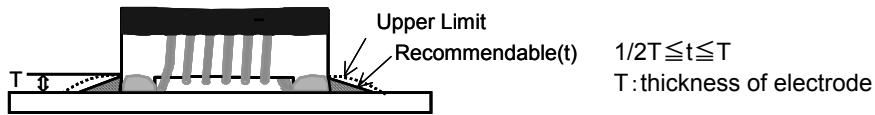

### 11.6 Product's location

The following shall be considered when designing and laying out P.C.B.'s.

- (1) P.C.B. shall be designed so that products are not subject to the mechanical stress due to warping the board.

[Products direction]

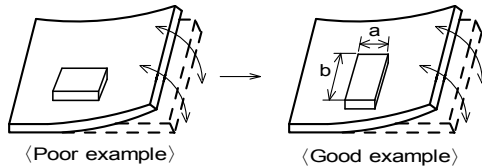

Products shall be located in the sideways direction (Length:a < b) to the mechanical stress.

- (2) Components location on P.C.B. separation.

It is effective to implement the following measures, to reduce stress in separating the board.

It is best to implement all of the following three measures; however, implement as many measures as possible to reduce stress.

Contents of Measures	Stress Level
(1) Turn the mounting direction of the component parallel to the board separation surface.	A > D *1
(2) Add slits in the board separation part.	A > B
(3) Keep the mounting position of the component away from the board separation surface.	A > C

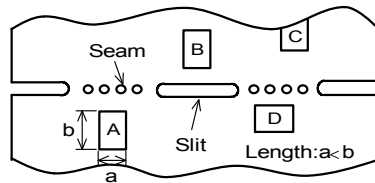

\*1 A > D is valid when stress is added vertically to the perforation as with Hand Separation. If a Cutting Disc is used, stress will be diagonal to the PCB, therefore A > D is invalid.

**(3) Mounting Components Near Screw Holes**

When a component is mounted near a screw hole, it may be affected by the board deflection that occurs during the tightening of the screw. Mount the component in a position as far away from the screw holes as possible.

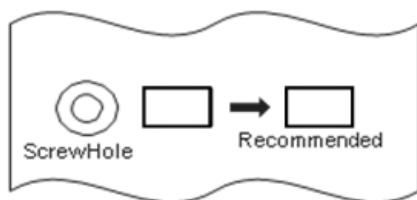
**11.7 Cleaning Conditions**

Products shall be cleaned on the following conditions.

- (1) Cleaning temperature shall be limited to 60°C max.(40°C max for IPA)
- (2) Ultrasonic cleaning shall comply with the following conditions with avoiding the resonance phenomenon at the mounted products and P.C.B.  
Power : 20 W / l max.      Frequency : 28kHz to 40kHz      Time : 5 min max.
- (3) Cleaner
  1. Alcohol type cleaner  
Isopropyl alcohol (IPA)
  2. Aqueous agent  
PINE ALPHA ST-100S
- (4) There shall be no residual flux and residual cleaner after cleaning.  
In the case of using aqueous agent, products shall be dried completely after rinse with de-ionized water in order to remove the cleaner.
- (5) Other cleaning      Please contact us.

**11.8 Resin coating**

The inductance value may change due to high cure-stress of resin to be used for coating/molding products. An open circuit issue may occur by mechanical stress caused by the resin, amount/cured shape of resin, or operating condition etc. Some resin contains some impurities or chloride possible to generate chlorine by hydrolysis under some operating condition may cause corrosion of wire of coil, leading to open circuit. So, please pay your careful attention when you select resin in case of coating/molding the products with the resin. Prior to use the coating resin, please make sure no reliability issue is observed by evaluating products mounted on your board.

**11.9 Caution for use**

- Sharp material such as a pair of tweezers or other material such as bristles of cleaning brush , shall not be touched to the winding portion to prevent the breaking of wire.
- Mechanical shock should not be applied to the products mounted on the board to prevent the breaking of the core.

**11.10 Notice of product handling at mounting**

In some mounting machines,when picking up components support pin pushes up the components from the bottom of plastic tape. In this case, please remove the support pin. The support pin may damage the components and break wire.

**11.11 Handling of a substrate**

After mounting products on a substrate, do not apply any stress to the product caused by bending or twisting to the substrate when cropping the substrate, inserting and removing a connector from the substrate or tightening screw to the substrate.

Excessive mechanical stress may cause cracking in the product.

Bending

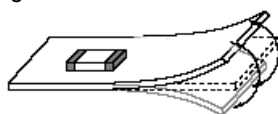

Twisting

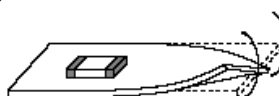

**11.12 Storage and Handling Requirements**

## (1) Storage period

Use the products within 12 months after delivered.

Solderability should be checked if this period is exceeded.

## (2) Storage conditions

• Products should be stored in the warehouse on the following conditions.

Temperature : -10°C to 40°C

Humidity : 15% to 85% relative humidity No rapid change on temperature and humidity

• Don't keep products in corrosive gases such as sulfur, chlorine gas or acid, or it may cause oxidization of electrode, resulting in poor solderability.

• Products should not be stored on bulk packaging condition to prevent the chipping of the core and the breaking of winding wire caused by the collision between the products.

• Products should be stored on the palette for the prevention of the influence from humidity, dust and so on.

• Products should be stored in the warehouse without heat shock, vibration, direct sunlight and so on.

## (3) Handling Condition

Care should be taken when transporting or handling product to avoid excessive vibration or mechanical shock.

**12.  Note**

(1) Please make sure that your product has been evaluated in view of your specifications with our product being mounted to your product.

(2) You are requested not to use our product deviating from the reference specifications.

(3) The contents of this reference specification are subject to change without advance notice.

Please approve our product specifications or transact the approval sheet for product specifications before ordering.

**<Electrical Performance:Measuring Method of Inductance/Q>**

To keep compatibility to other vender's product, Inductance and Q value shall be measured in following method.

1) Residual elements and stray elements of test fixture can be described by F-parameter shown in following.

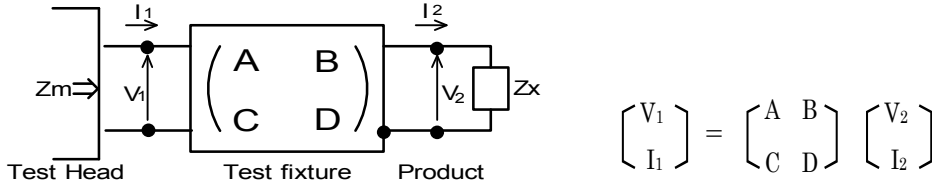

(2) The impedance of chip coil Zx and measured value Zm can be described by input/output current/voltage.

$$Z_m = \frac{V_1}{I_1}, \quad Z_x = \frac{V_2}{I_2}$$

(3) Thus, the relation between Zx and Zm is followin

$$Z_x = \alpha \frac{Z_m - \beta}{1 - Z_m \Gamma}$$

Where,  $\alpha = D/A = 1$   
 $\beta = B/D = Z_{sm} - (1 - Y_{om} Z_{sm}) Z_{ss}$   
 $\Gamma = C/A = Y_{om}$

$Z_{sm}$ :measured impedance of short chip  
 $Z_{ss}$ :residual impedance of short chip (=equivalent series Inductance X)  
 $Y_{om}$ :measured admittance when opening the fixture

**Important:** X:Zss shall be defined as correction value to fit nominal inductance of other venders' products.  
 Please input X value instead of equivalent series Inductance (ShortL) on test equipment calibration.

(4) Lx and Qx shall be calculated with the following equation.

$$L_x = \frac{\text{Im}(Z_x)}{2 \pi f}, \quad Q_x = \frac{\text{Im}(Z_x)}{\text{Re}(Z_x)} \quad f : \text{Measuring frequency}$$

Inductance and Q value shall be measured after this calibration setting.  
 In addition, Q value should be measured under our standard calibration setting of residual impedance, 0.771nH.

Chart. equivalent series Inductance to fit nominal inductance of other vendors' products.

MURATA Part Number	Inductance	
	X [nH] equivalent series Inductance	Measuring Frequency
LQW2UAS12N_00	0.511	50
LQW2UAS18N_00	0.321	50
LQW2UAS22N_00	0.941	50
LQW2UAS27N_00	0.651	50
LQW2UAS33N_00	1.711	50
LQW2UAS39N_00	0.741	50
LQW2UAS47N_00	2.071	50
LQW2UAS56N_00	2.351	50
LQW2UAS68N_00	2.281	50
LQW2UAS82N_00	2.921	50
LQW2UASR10_00	3.351	25
LQW2UASR12_00	3.871	25
LQW2UASR15_00	4.371	25
LQW2UASR18_00	5.271	25
LQW2UASR22_00	3.271	25
LQW2UASR27_00	8.871	25
LQW2UASR33_00	12.771	25
LQW2UASR39_00	22.271	25
LQW2UASR47_00	20.971	25
LQW2UASR56_00	24.971	25
LQW2UASR62_00	28.371	25
LQW2UASR68_00	44.271	25
LQW2UASR75_00	35.371	25
LQW2UASR82_00	47.171	25
LQW2UASR91_00	56.371	25
LQW2UAS1R0_00	79.171	25
LQW2UAS1R2_00	15.771	7.9
LQW2UAS1R5_00	5.771	7.9
LQW2UAS1R8_00	6.771	7.9
LQW2UAS2R2_00	25.771	7.9
LQW2UAS2R7_00	63.771	7.9
LQW2UAS3R3_00	91.771	7.9
LQW2UAS3R9_00	67.771	7.9
LQW2UAS4R7_00	163.771	7.9

## Looking for pricing, stock, or lifecycle information?

Click below to explore more details on WIN SOURCE:

- ⊖ [View LQW2UASR75G00L on WIN SOURCE](#)
- ⊖ [Murata Electronics North America Information](#)

## Optimize Your Supply Chain with WIN SOURCE Solutions

- ✓ Global Sourcing Solution
- ✓ Obsolete Management
- ✓ Cost Control Management
- ✓ Shortage Management
- ✓ Alternative Solution
- ✓ Excess Inventory Management