



**THE DATASHEET OF  
SN74HC125DRG4**



## SNx4HC125 Quadruple Bus Buffer Gates With 3-State Outputs

### 1 Features

- Wide Operating Voltage Range of 2 V to 6 V
- High-Current 3-State Outputs Interface Directly With System Bus or Can Drive Up to 15 LSTTL Loads
- Low Power Consumption, 80- $\mu$ A Maximum  $I_{CC}$
- Typical  $t_{pd} = 11$  ns
- $\pm 6$ -mA Output Drive at 5 V
- Low Input Current of 1  $\mu$ A Maximum

### 2 Applications

- TV Set-Top Boxes and DVRs
- E-meters
- Smart Grids: Transmission Line Monitoring
- Printers and Computer Peripherals
- Building Security: Control Panels
- IP Phones
- Test and Measurement: Range Readers
- Smart Grids: Distribution Feeder Protection Relay

### 3 Description

The SNx4HC125 device is a quadruple set of bus buffer gates and features independent line drivers with 3-state outputs. The SNx4HC125 is designed for 2-V to 6-V  $V_{CC}$  operation. Each output is disabled when the associated output-enable ( $\overline{OE}$ ) input is high.

To ensure the high-impedance state during power up or power down,  $\overline{OE}$  should be tied to  $V_{CC}$  through a pullup resistor; the minimum value of the resistor is determined by the current-sinking capability of the driver.

#### Device Information<sup>(1)</sup>

PART NUMBER	PACKAGE	BODY SIZE (NOM)
SN74HC125N	PDIP (14)	18.30 mm x 6.35 mm
SN74HC125D	SOIC (14)	8.65 mm x 6.00 mm
SN74HC125W	SO (14)	10.20 mm x 5.30 mm
SN74HC125DB	SSOP (14)	6.20 mm x 5.30 mm
SN74HC125PW	TSSOP (14)	5.00 mm x 4.40 mm
SN54HC125J	CDIP (14)	19.90 mm x 6.90 mm
SN54HC125FK	LCCC (20)	8.90 mm x 8.44 mm

(1) For all available packages, see the orderable addendum at the end of the data sheet.

#### Logic Diagram (Positive Logic)

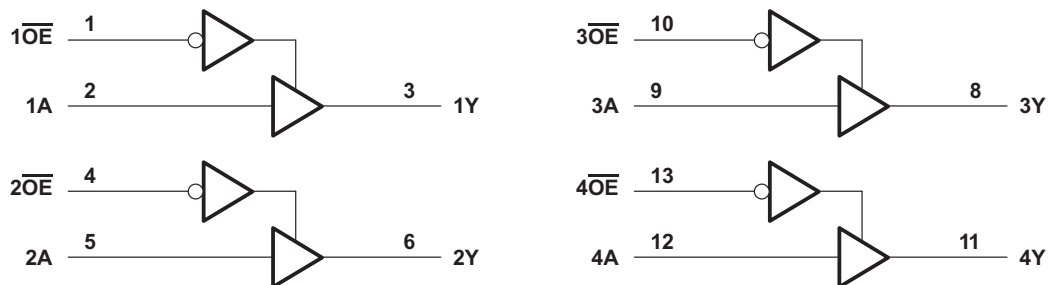

Pin numbers shown are for the D, DB, J, N, NS, PW, and W packages.



An IMPORTANT NOTICE at the end of this data sheet addresses availability, warranty, changes, use in safety-critical applications, intellectual property matters and other important disclaimers. PRODUCTION DATA.

On products compliant to MIL-PRF-38535, all parameters are tested unless otherwise noted. On all other products, production processing does not necessarily include testing of all parameters.

## Table of Contents

<b>1 Features</b> .....	<b>1</b>	6.15 Typical Characteristics .....	<b>8</b>
<b>2 Applications</b> .....	<b>1</b>	<b>7 Parameter Measurement Information</b> .....	<b>9</b>
<b>3 Description</b> .....	<b>1</b>	<b>8 Detailed Description</b> .....	<b>10</b>
<b>4 Revision History</b> .....	<b>2</b>	8.1 Overview .....	<b>10</b>
<b>5 Pin Configuration and Functions</b> .....	<b>3</b>	8.2 Functional Block Diagram .....	<b>10</b>
<b>6 Specifications</b> .....	<b>4</b>	8.3 Feature Description .....	<b>10</b>
6.1 Absolute Maximum Ratings .....	<b>4</b>	8.4 Device Functional Modes .....	<b>10</b>
6.2 ESD Ratings .....	<b>4</b>	<b>9 Application and Implementation</b> .....	<b>11</b>
6.3 Recommended Operating Conditions .....	<b>4</b>	9.1 Application Information .....	<b>11</b>
6.4 Thermal Information .....	<b>4</b>	9.2 Typical Application .....	<b>11</b>
6.5 Electrical Characteristics, $T_A = 25^\circ\text{C}$ .....	<b>5</b>	<b>10 Power Supply Recommendations</b> .....	<b>12</b>
6.6 Electrical Characteristics, SN54HC125 .....	<b>5</b>	<b>11 Layout</b> .....	<b>12</b>
6.7 Electrical Characteristics, SN74HC125 .....	<b>6</b>	11.1 Layout Guidelines .....	<b>12</b>
6.8 Switching Characteristics, $T_A = 25^\circ\text{C}$ , $C_L = 50\text{ pF}$ .....	<b>6</b>	11.2 Layout Example .....	<b>12</b>
6.9 Switching Characteristics, SN54HC125, $C_L = 50\text{ pF}$ .....	<b>6</b>	<b>12 Device and Documentation Support</b> .....	<b>13</b>
6.10 Switching Characteristics, SN74HC125, $C_L = 50\text{ pF}$ .....	<b>7</b>	12.1 Documentation Support .....	<b>13</b>
6.11 Switching Characteristics, $T_A = 25^\circ\text{C}$ , $C_L = 150\text{ pF}$ .....	<b>7</b>	12.2 Related Links .....	<b>13</b>
6.12 Switching Characteristics, SN54HC125, $C_L = 150\text{ pF}$ .....	<b>7</b>	12.3 Community Resources .....	<b>13</b>
6.13 Switching Characteristics, SN74HC125, $C_L = 150\text{ pF}$ .....	<b>8</b>	12.4 Trademarks .....	<b>13</b>
6.14 Operating Characteristics .....	<b>8</b>	12.5 Electrostatic Discharge Caution .....	<b>13</b>
		12.6 Glossary .....	<b>13</b>
		<b>13 Mechanical, Packaging, and Orderable Information</b> .....	<b>13</b>

## 4 Revision History

NOTE: Page numbers for previous revisions may differ from page numbers in the current version.

Changes from Revision D (August 2003) to Revision E	Page
• Added <i>ESD Ratings</i> table, <i>Feature Description</i> section, <i>Device Functional Modes</i> , <i>Application and Implementation</i> section, <i>Power Supply Recommendations</i> section, <i>Layout</i> section, <i>Device and Documentation Support</i> section, and <i>Mechanical, Packaging, and Orderable Information</i> section. ....	<b>1</b>
• Removed <i>Ordering Information</i> table. ....	<b>1</b>

## 5 Pin Configuration and Functions

D, DB, N, NS, J, or PW Package  
14-Pin SOIC, SSOP, PDIP, SO, CDIP, or TSSOP  
Top View

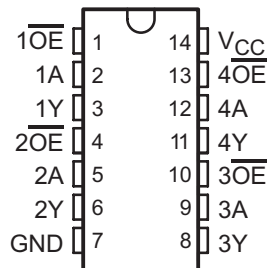

FK Package  
20-Pin LCCC  
Top View

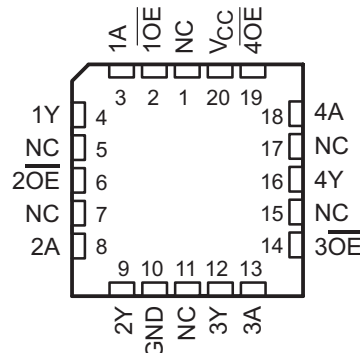

Pin Functions<sup>(1)</sup>

NAME	PIN		I/O	DESCRIPTION
	SOIC, SSOP, PDIP, SO, CDIP, or TSSOP	LCCC		
1A	2	3	I	Input
$\overline{1OE}$	1	2	I	Output Enable (Active Low)
1Y	3	4	O	Output
2A	5	8	I	Input
$\overline{2OE}$	4	6	I	Output Enable (Active Low)
2Y	6	9	O	Output
3A	9	13	I	Input
$\overline{3OE}$	10	14	I	Output Enable (Active Low)
3Y	8	12	O	Output
4A	12	18	I	Input
$\overline{4OE}$	13	19	I	Output Enable (Active Low)
4Y	11	16	O	Output
GND	7	10	—	Ground
NC <sup>(2)</sup>	—	1, 5, 7, 11, 15, 17	—	Not connected
V <sub>CC</sub>	14	20	—	Power

(1) See [Mechanical, Packaging, and Orderable Information](#) for dimensions

(2) NC – No internal connection

## 6 Specifications

### 6.1 Absolute Maximum Ratings

over operating free-air temperature range (unless otherwise noted)<sup>(1)</sup>

		MIN	MAX	UNIT
V <sub>CC</sub>	Supply voltage	-0.5	7	V
I <sub>IK</sub>	Input clamp current <sup>(2)</sup>	V <sub>I</sub> < 0 or V <sub>I</sub> > V <sub>CC</sub>		±20 mA
I <sub>OK</sub>	Output clamp current <sup>(2)</sup>	V <sub>O</sub> < 0 or V <sub>O</sub> > V <sub>CC</sub>		±20 mA
I <sub>O</sub>	Continuous output current	V <sub>O</sub> = 0 to V <sub>CC</sub>		±35 mA
	Continuous current through V <sub>CC</sub> or GND			±70 mA
T <sub>j</sub>	Junction temperature	-65	150	°C
T <sub>stg</sub>	Storage temperature	-65	150	°C

- (1) Stresses beyond those listed under *Absolute Maximum Ratings* may cause permanent damage to the device. These are stress ratings only, which do not imply functional operation of the device at these or any other conditions beyond those indicated under *Recommended Operating Conditions*. Exposure to absolute-maximum-rated conditions for extended periods may affect device reliability.
- (2) The input and output voltage ratings may be exceeded if the input and output current ratings are observed.

### 6.2 ESD Ratings

		VALUE	UNIT
V <sub>(ESD)</sub>	Electrostatic discharge	Human body model (HBM), per ANSI/ESDA/JEDEC JS-001 <sup>(1)</sup>	2000
		Charged-device model (CDM), per JEDEC specification JESD22-C101 <sup>(2)</sup>	500

- (1) JEDEC document JEP155 states that 500-V HBM allows safe manufacturing with a standard ESD control process.
- (2) JEDEC document JEP157 states that 250-V CDM allows safe manufacturing with a standard ESD control process.

### 6.3 Recommended Operating Conditions

See <sup>(1)</sup>.

		MIN	NOM	MAX	UNIT
V <sub>CC</sub>	Supply voltage	2	5	6	V
V <sub>IH</sub>	High-level input voltage	V <sub>CC</sub> = 2 V	1.5		V
		V <sub>CC</sub> = 4.5 V	3.15		
		V <sub>CC</sub> = 6 V	4.2		
V <sub>IL</sub>	Low-level input voltage	V <sub>CC</sub> = 2 V		0.5	V
		V <sub>CC</sub> = 4.5 V		1.35	
		V <sub>CC</sub> = 6 V		1.8	
V <sub>I</sub>	Input voltage	0		V <sub>CC</sub>	V
V <sub>O</sub>	Output voltage	0		V <sub>CC</sub>	V
Δt/Δv	Input transition rise and fall time	V <sub>CC</sub> = 2 V		1000	ns
		V <sub>CC</sub> = 4.5 V		500	
		V <sub>CC</sub> = 6 V		400	
T <sub>A</sub>	Operating free-air temperature	SN54HC125	-55	125	°C
		SN74HC125	-40	85	

- (1) All unused inputs of the device must be held at V<sub>CC</sub> or GND to ensure proper device operation. Refer to the TI application report, *Implications of Slow or Floating CMOS Inputs*, [SCBA004](#).

### 6.4 Thermal Information

THERMAL METRIC <sup>(1)</sup>	SN74LVC1G06					UNIT	
	D (SOIC)	DB (SSOP)	N (PDIP)	NS (SOP)	PW (TSSOP)		
	14 PINS	14 PINS	14 PINS	14 PINS	14 PINS		
R <sub>θJA</sub>	Junction-to-ambient thermal resistance	86	96	80	76	113	°C/W

- (1) For more information about traditional and new thermal metrics, see the *Semiconductor and IC Package Thermal Metrics* application report, [SPRA953](#).

## 6.5 Electrical Characteristics, $T_A = 25^\circ\text{C}$

over recommended operating free-air temperature range (unless otherwise noted)

PARAMETER	TEST CONDITIONS	$V_{CC}$	MIN	TYP	MAX	UNIT	
$V_{OH}$	$V_I = V_{IH}$ or $V_{IL}$	$I_{OH} = -20\ \mu\text{A}$	2 V	1.9	1.998	V	
			4.5 V	4.4	4.499		
			6 V	5.9	5.999		
		$I_{OH} = -6\ \text{mA}$	4.5 V	3.98	4.3		
			6 V	5.48	5.8		
$V_{OL}$	$V_I = V_{IH}$ or $V_{IL}$	$I_{OL} = 20\ \mu\text{A}$	2 V		0.002	0.1	V
			4.5 V		0.001	0.1	
			6 V		0.001	0.1	
		$I_{OL} = 6\ \text{mA}$	4.5 V		0.17	0.26	
			6 V		0.15	0.26	
$I_I$	$V_I = V_{CC}$ or 0	6 V		$\pm 0.1$	$\pm 100$	nA	
$I_{OZ}$	$V_O = V_{CC}$ or 0	6 V		$\pm 0.01$	$\pm 0.5$	$\mu\text{A}$	
$I_{CC}$	$V_I = V_{CC}$ or 0, $I_O = 0$	6 V			8	$\mu\text{A}$	
$C_i$		2 V to 6 V		3	10	pF	

## 6.6 Electrical Characteristics, SN54HC125

over recommended operating free-air temperature range (unless otherwise noted)

PARAMETER	TEST CONDITIONS	$V_{CC}$	MIN	MAX	UNIT
$V_{OH}$	$V_I = V_{IH}$ or $V_{IL}$	$I_{OH} = -20\ \mu\text{A}$	2 V	1.9	V
			4.5 V	4.4	
			6 V	5.9	
		$I_{OH} = -6\ \text{mA}$	4.5 V	3.7	
			6 V	5.2	
$V_{OL}$	$V_I = V_{IH}$ or $V_{IL}$	$I_{OL} = 20\ \mu\text{A}$	2 V	0.1	V
			4.5 V	0.1	
			6 V	0.1	
		$I_{OL} = 6\ \text{mA}$	4.5 V	0.4	
			6 V	0.4	
$I_I$	$V_I = V_{CC}$ or 0	6 V		$\pm 1000$	nA
$I_{OZ}$	$V_O = V_{CC}$ or 0	6 V		$\pm 10$	$\mu\text{A}$
$I_{CC}$	$V_I = V_{CC}$ or 0, $I_O = 0$	6 V		160	$\mu\text{A}$
$C_i$		2 V to 6 V		10	pF

### 6.7 Electrical Characteristics, SN74HC125

over recommended operating free-air temperature range (unless otherwise noted)

PARAMETER	TEST CONDITIONS		V <sub>CC</sub>	MIN	MAX	UNIT
V <sub>OH</sub>	V <sub>I</sub> = V <sub>IH</sub> or V <sub>IL</sub>	I <sub>OH</sub> = -20 μA	2 V	1.9		V
			4.5 V	4.4		
			6 V	5.9		
		I <sub>OH</sub> = -6 mA	4.5 V	3.84		
			6 V	5.34		
V <sub>OL</sub>	V <sub>I</sub> = V <sub>IH</sub> or V <sub>IL</sub>	I <sub>OL</sub> = 20 μA	2 V		0.1	V
			4.5 V		0.1	
			6 V		0.1	
		I <sub>OL</sub> = 6 mA	4.5 V		0.33	
			6 V		0.33	
I <sub>I</sub>	V <sub>I</sub> = V <sub>CC</sub> or 0		6 V		±1000	nA
I <sub>OZ</sub>	V <sub>O</sub> = V <sub>CC</sub> or 0		6 V		±5	μA
I <sub>CC</sub>	V <sub>I</sub> = V <sub>CC</sub> or 0, I <sub>O</sub> = 0		6 V		80	μA
C <sub>i</sub>			2 V to 6 V		10	pF

### 6.8 Switching Characteristics, T<sub>A</sub> = 25°C, C<sub>L</sub> = 50 pF

over recommended operating free-air temperature range, C<sub>L</sub> = 50 pF (unless otherwise noted) (see Figure 2)

PARAMETER	FROM (INPUT)	TO (OUTPUT)	V <sub>CC</sub>	MIN	TYP	MAX	UNIT
t <sub>pd</sub>	A	Y	2 V		48	150	ns
			4.5 V		14	30	
			6 V		11	26	
t <sub>en</sub>	$\overline{OE}$	Y	2 V		53	150	ns
			4.5 V		14	30	
			6 V		11	26	
t <sub>dis</sub>	$\overline{OE}$	Y	2 V		30	150	ns
			4.5 V		15	30	
			6 V		14	26	
t <sub>t</sub>		Any	2 V		28	75	ns
			4.5 V		8	15	
			6 V		6	13	

### 6.9 Switching Characteristics, SN54HC125, C<sub>L</sub> = 50 pF

over recommended operating free-air temperature range, C<sub>L</sub> = 50 pF (unless otherwise noted) (see Figure 2)

PARAMETER	FROM (INPUT)	TO (OUTPUT)	V <sub>CC</sub>	MIN	MAX	UNIT
t <sub>pd</sub>	A	Y	2 V		150	ns
			4.5 V		36	
			6 V		25	
t <sub>en</sub>	$\overline{OE}$	Y	2 V		180	ns
			4.5 V		36	
			6 V		31	
t <sub>dis</sub>	$\overline{OE}$	Y	2 V		180	ns
			4.5 V		36	
			6 V		31	

### Switching Characteristics, SN54HC125, $C_L = 50$ pF (continued)

over recommended operating free-air temperature range,  $C_L = 50$  pF (unless otherwise noted) (see [Figure 2](#))

PARAMETER	FROM (INPUT)	TO (OUTPUT)	$V_{CC}$	MIN	MAX	UNIT
$t_t$		Any	2 V		90	ns
			4.5 V		18	
			6 V		15	

### 6.10 Switching Characteristics, SN74HC125, $C_L = 50$ pF

over recommended operating free-air temperature range,  $C_L = 50$  pF (unless otherwise noted) (see [Figure 2](#))

PARAMETER	FROM (INPUT)	TO (OUTPUT)	$V_{CC}$	MIN	MAX	UNIT
$t_{pd}$	A	Y	2 V		150	ns
			4.5 V		30	
			6 V		26	
$t_{en}$	$\overline{OE}$	Y	2 V		150	ns
			4.5 V		30	
			6 V		26	
$t_{dis}$	$\overline{OE}$	Y	2 V		150	ns
			4.5 V		30	
			6 V		26	
$t_t$		Any	2 V		75	ns
			4.5 V		15	
			6 V		13	

### 6.11 Switching Characteristics, $T_A = 25^\circ\text{C}$ , $C_L = 150$ pF

over recommended operating free-air temperature range,  $C_L = 150$  pF (unless otherwise noted) (see [Figure 2](#))

PARAMETER	FROM (INPUT)	TO (OUTPUT)	$V_{CC}$	MIN	TYP	MAX	UNIT
$t_{pd}$	A	Y	2 V		67	150	ns
			4.5 V		19	30	
			6 V		15	25	
$t_{en}$	$\overline{OE}$	Y	2 V		100	135	ns
			4.5 V		20	27	
			6 V		17	23	
$t_t$		Any	2 V		45	210	ns
			4.5 V		17	42	
			6 V		13	36	

### 6.12 Switching Characteristics, SN54HC125, $C_L = 150$ pF

over recommended operating free-air temperature range,  $C_L = 150$  pF (unless otherwise noted) (see [Figure 2](#))

PARAMETER	FROM (INPUT)	TO (OUTPUT)	$V_{CC}$	MIN	MAX	UNIT
$t_{pd}$	A	Y	2 V		225	ns
			4.5 V		45	
			6 V		39	
$t_{en}$	$\overline{OE}$	Y	2 V		200	ns
			4.5 V		40	
			6 V		34	

### Switching Characteristics, SN54HC125, $C_L = 150$ pF (continued)

over recommended operating free-air temperature range,  $C_L = 150$  pF (unless otherwise noted) (see [Figure 2](#))

PARAMETER	FROM (INPUT)	TO (OUTPUT)	$V_{CC}$	MIN	MAX	UNIT
$t_t$		Any	2 V		315	ns
			4.5 V		63	
			6 V		53	

### 6.13 Switching Characteristics, SN74HC125, $C_L = 150$ pF

over recommended operating free-air temperature range,  $C_L = 150$  pF (unless otherwise noted) (see [Figure 2](#))

PARAMETER	FROM (INPUT)	TO (OUTPUT)	$V_{CC}$	MIN	MAX	UNIT
$t_{pd}$	A	Y	2 V		190	ns
			4.5 V		38	
			6 V		32	
$t_{en}$	$\overline{OE}$	Y	2 V		170	ns
			4.5 V		34	
			6 V		29	
$t_t$		Any	2 V		265	ns
			4.5 V		53	
			6 V		45	

### 6.14 Operating Characteristics

$T_A = 25^\circ\text{C}$

PARAMETER	TEST CONDITIONS	TYP	UNIT
$C_{pd}$ Power dissipation capacitance per gate	No load	45	pF

### 6.15 Typical Characteristics

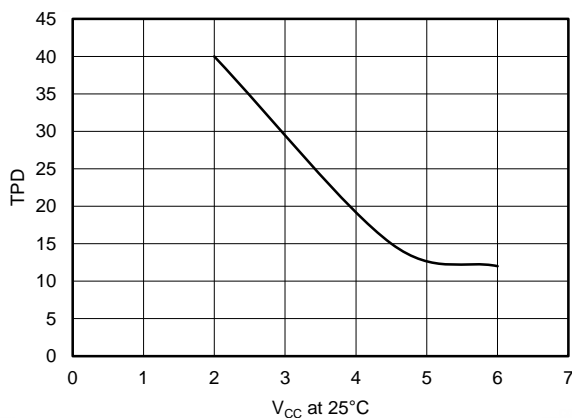
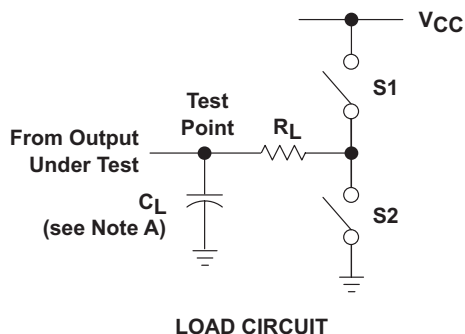
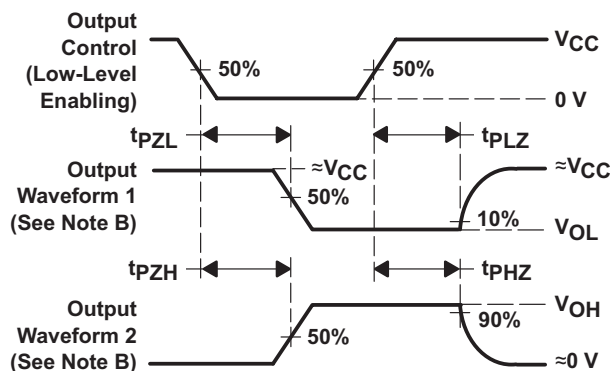
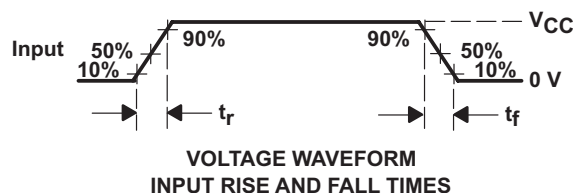
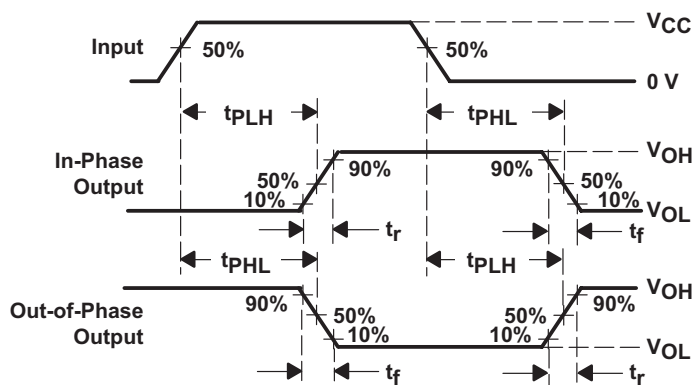

Figure 1. TPD vs  $V_{CC}$  at  $25^\circ\text{C}$

## 7 Parameter Measurement Information



PARAMETER		$R_L$	$C_L$	S1	S2
$t_{en}$	$t_{PZH}$	1 k $\Omega$	50 pF or 150 pF	Open	Closed
	$t_{PZL}$			Closed	Open
$t_{dis}$	$t_{PHZ}$	1 k $\Omega$	50 pF	Open	Closed
	$t_{PLZ}$			Closed	Open
$t_{pd}$ or $t_t$		--	50 pF or 150 pF	Open	Open



- NOTES: A.  $C_L$  includes probe and test-fixture capacitance.  
 B. Waveform 1 is for an output with internal conditions such that the output is low except when disabled by the output control. Waveform 2 is for an output with internal conditions such that the output is high except when disabled by the output control.  
 C. Phase relationships between waveforms were chosen arbitrarily. All input pulses are supplied by generators having the following characteristics:  $PRR \leq 1$  MHz,  $Z_O = 50 \Omega$ ,  $t_r = 6$  ns,  $t_f = 6$  ns.  
 D. The outputs are measured one at a time with one input transition per measurement.  
 E.  $t_{PLZ}$  and  $t_{PHZ}$  are the same as  $t_{dis}$ .  
 F.  $t_{PZL}$  and  $t_{PZH}$  are the same as  $t_{en}$ .  
 G.  $t_{PLH}$  and  $t_{PHL}$  are the same as  $t_{pd}$ .

**Figure 2. Load Circuit and Voltage Waveforms**

## 8 Detailed Description

### 8.1 Overview

The SNx4HC125 offers 4 independent gate buffers capable of sinking or sourcing 6 mA at 5-V  $V_{CC}$ . Each buffer also integrates a 3-state output, or high impedance output. To enable the device's 3-state output, set the corresponding  $\overline{OE}$  input to a HIGH logic level.

Major benefits of using HC logic include both the technology's flexibility of input  $V_{CC}$  (2 V to 6 V) and high-speed capability (11 ns typical  $t_{pd}$ ).

### 8.2 Functional Block Diagram

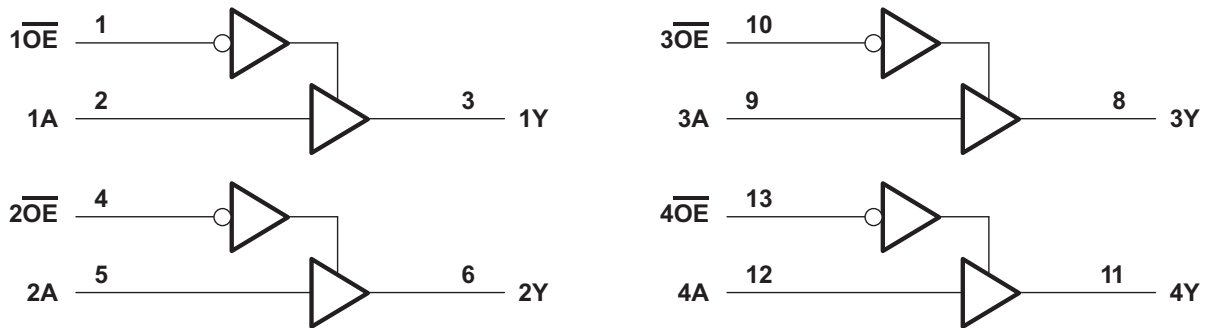

Pin numbers shown are for the D, DB, J, N, NS, PW, and W packages.

### 8.3 Feature Description

The 3-state outputs enable design choices such as connecting multiple outputs together, as long as the 3-state controls are used correctly. In a typical example, without 3-state outputs, if two outputs were connected to the same input on an adjacent system, and each output was trying to drive a different logic level (one HIGH, one LOW), the device could short-circuit and become damaged. With 3-state output functionality, the outputs can be configured so that when one output is driving an output signal, the others are set to high impedance and prevent any damage to the device.

### 8.4 Device Functional Modes

Table 1 lists the functional modes of the SNx4HC125.

Table 1. Function Table

INPUTS		OUTPUT
$\overline{OE}$	A	Y
L	H	H
L	L	L
H	X	Z

## 9 Application and Implementation

### NOTE

Information in the following applications sections is not part of the TI component specification, and TI does not warrant its accuracy or completeness. TI's customers are responsible for determining suitability of components for their purposes. Customers should validate and test their design implementation to confirm system functionality.

### 9.1 Application Information

The SNx4HC125 can be used to buffer noisy or weak input signals in order to clean up these signals and drive a strong logic level to a processor or other sampling system.

### 9.2 Typical Application

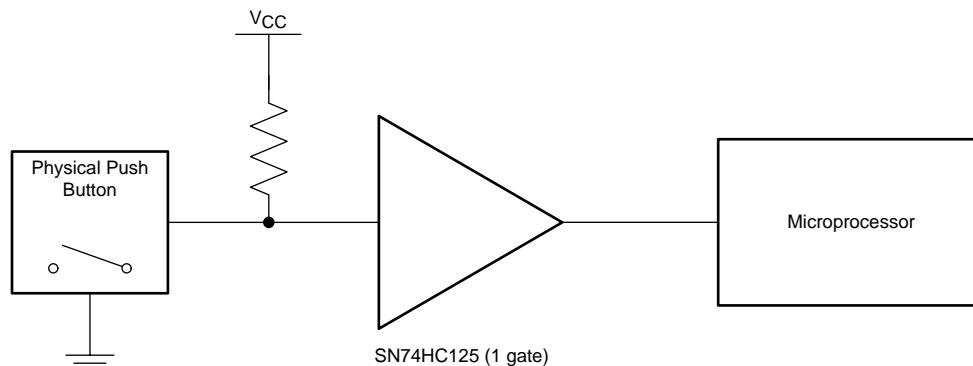

Figure 3. Typical Application Diagram

#### 9.2.1 Design Requirements

This device uses CMOS technology and has balanced output drive. Take care to avoid bus contention because it can drive currents that would exceed maximum limits. The high drive will also create fast edges into light loads so routing and load conditions should be considered to prevent ringing.

#### 9.2.2 Detailed Design Procedure

##### 1. Recommended Input Conditions

- Rise time and fall time specs. See ( $\Delta t/\Delta V$ ) in the [Recommended Operating Conditions](#) table.
- Specified high and low levels. See ( $V_{IH}$  and  $V_{IL}$ ) in the [Recommended Operating Conditions](#) table.
- Inputs are overvoltage tolerant allowing them to go as high as ( $V_I$  maximum) in the [Recommended Operating Conditions](#) table at any valid  $V_{CC}$ .

##### 2. Recommend Output Conditions

- Load currents should not exceed ( $I_O$  maximum) per output and should not exceed (continuous current through  $V_{CC}$  or GND) total current for the part. These limits are located in the [Absolute Maximum Ratings](#) table.
- Outputs should not be pulled above  $V_{CC}$ .

## Typical Application (continued)

### 9.2.3 Application Curve

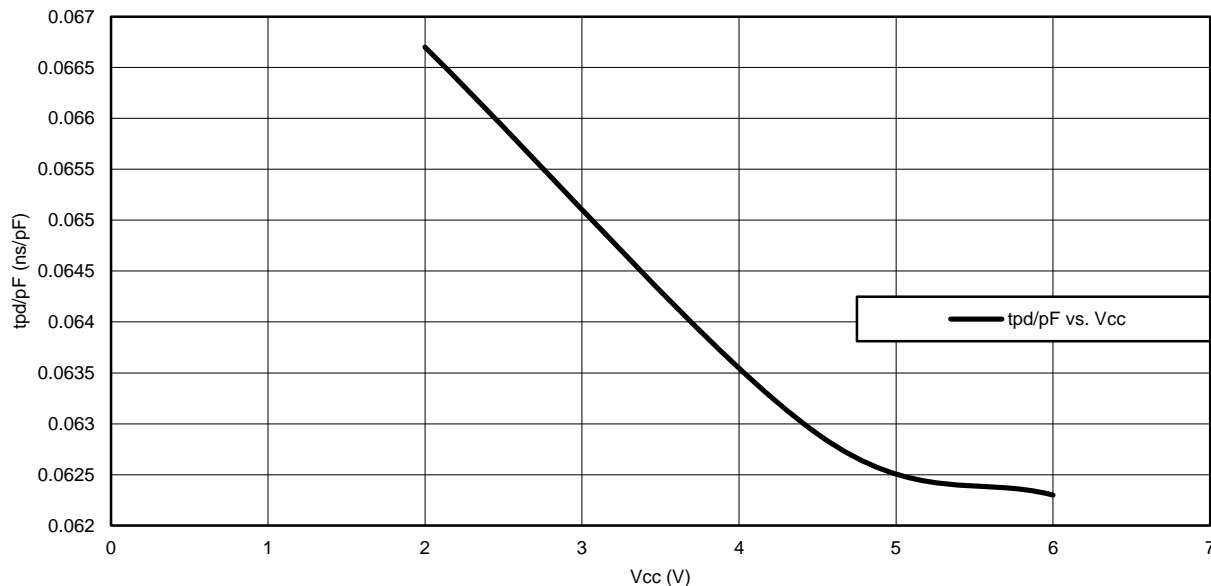

Figure 4. tpd/pF vs V<sub>CC</sub> at 25°C

## 10 Power Supply Recommendations

The power supply can be any voltage between the minimum and maximum supply voltage rating located in the [Recommended Operating Conditions](#) table.

Each V<sub>CC</sub> pin should have a good bypass capacitor to prevent power disturbance. For devices with a single supply, a 0.1-μF capacitor is recommended and if there are multiple V<sub>CC</sub> pins then a 0.01-μF or 0.022-μF capacitor is recommended for each power pin. It is ok to parallel multiple bypass caps to reject different frequencies of noise. 0.1-μF and 1-μF capacitors are commonly used in parallel. The bypass capacitor should be installed as close to the power pin as possible for best results.

## 11 Layout

### 11.1 Layout Guidelines

When using multiple bit logic devices inputs must not ever float. In many cases, functions or parts of functions of digital logic devices are unused; for example, when only two inputs of a triple-input AND gate are used or only 3 of the 4 buffer gates are used. Such input pins must not be left unconnected because the undefined voltages at the outside connections result in undefined operational states. Specified below are the rules that must be observed under all circumstances. All unused inputs of digital logic devices must be connected to a high or low bias to prevent them from floating. The logic level that should be applied to any particular unused input depends on the function of the device. Generally they will be tied to GND or V<sub>CC</sub> whichever make more sense or is more convenient.

### 11.2 Layout Example

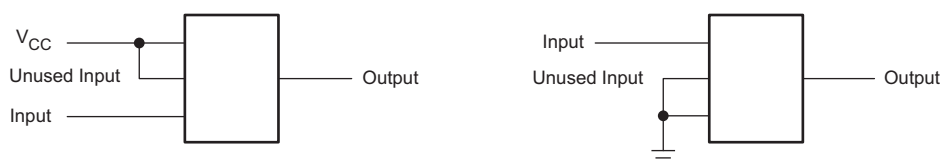

Figure 5. Layout Diagram

## 12 Device and Documentation Support

### 12.1 Documentation Support

#### 12.1.1 Related Documentation

For related documentation, see the following:

- *Implications of Slow or Floating CMOS Inputs*, [SCBA004](#).
- *Introduction to Logic*, [SLVA700](#)

### 12.2 Related Links

The table below lists quick access links. Categories include technical documents, support and community resources, tools and software, and quick access to sample or buy.

**Table 2. Related Links**

PARTS	PRODUCT FOLDER	SAMPLE & BUY	TECHNICAL DOCUMENTS	TOOLS & SOFTWARE	SUPPORT & COMMUNITY
SN54HC125	<a href="#">Click here</a>	<a href="#">Click here</a>	<a href="#">Click here</a>	<a href="#">Click here</a>	<a href="#">Click here</a>
SN74HC125	<a href="#">Click here</a>	<a href="#">Click here</a>	<a href="#">Click here</a>	<a href="#">Click here</a>	<a href="#">Click here</a>

### 12.3 Community Resources

The following links connect to TI community resources. Linked contents are provided "AS IS" by the respective contributors. They do not constitute TI specifications and do not necessarily reflect TI's views; see TI's [Terms of Use](#).

**TI E2E™ Online Community** *TI's Engineer-to-Engineer (E2E) Community*. Created to foster collaboration among engineers. At [e2e.ti.com](http://e2e.ti.com), you can ask questions, share knowledge, explore ideas and help solve problems with fellow engineers.

**Design Support** *TI's Design Support* Quickly find helpful E2E forums along with design support tools and contact information for technical support.

### 12.4 Trademarks

E2E is a trademark of Texas Instruments.  
All other trademarks are the property of their respective owners.

### 12.5 Electrostatic Discharge Caution



These devices have limited built-in ESD protection. The leads should be shorted together or the device placed in conductive foam during storage or handling to prevent electrostatic damage to the MOS gates.

### 12.6 Glossary

[SLYZ022](#) — *TI Glossary*.

This glossary lists and explains terms, acronyms, and definitions.

## 13 Mechanical, Packaging, and Orderable Information

The following pages include mechanical packaging and orderable information. This information is the most current data available for the designated devices. This data is subject to change without notice and revision of this document. For browser based versions of this data sheet, refer to the left hand navigation.

**PACKAGING INFORMATION**

Orderable Device	Status (1)	Package Type	Package Drawing	Pins	Package Qty	Eco Plan (2)	Lead/Ball Finish (6)	MSL Peak Temp (3)	Op Temp (°C)	Device Marking (4/5)	Samples
5962-87721012A	ACTIVE	LCCC	FK	20	1	TBD	POST-PLATE	N / A for Pkg Type	-55 to 125	5962- 87721012A SNJ54HC 125FK	<a href="#">Samples</a>
5962-8772101CA	ACTIVE	CDIP	J	14	1	TBD	A42	N / A for Pkg Type	-55 to 125	5962-8772101CA SNJ54HC125J	<a href="#">Samples</a>
SN54HC125J	ACTIVE	CDIP	J	14	1	TBD	A42	N / A for Pkg Type	-55 to 125	SN54HC125J	<a href="#">Samples</a>
SN74HC125D	ACTIVE	SOIC	D	14	50	Green (RoHS & no Sb/Br)	CU NIPDAU	Level-1-260C-UNLIM	-40 to 85	HC125	<a href="#">Samples</a>
SN74HC125DBR	ACTIVE	SSOP	DB	14	2000	Green (RoHS & no Sb/Br)	CU NIPDAU	Level-1-260C-UNLIM	-40 to 85	HC125	<a href="#">Samples</a>
SN74HC125DE4	ACTIVE	SOIC	D	14	50	Green (RoHS & no Sb/Br)	CU NIPDAU	Level-1-260C-UNLIM	-40 to 85	HC125	<a href="#">Samples</a>
SN74HC125DR	ACTIVE	SOIC	D	14	2500	Green (RoHS & no Sb/Br)	CU NIPDAU   CU SN	Level-1-260C-UNLIM	-40 to 85	HC125	<a href="#">Samples</a>
SN74HC125DRE4	ACTIVE	SOIC	D	14	2500	Green (RoHS & no Sb/Br)	CU NIPDAU	Level-1-260C-UNLIM	-40 to 85	HC125	<a href="#">Samples</a>
SN74HC125DRG4	ACTIVE	SOIC	D	14	2500	Green (RoHS & no Sb/Br)	CU NIPDAU	Level-1-260C-UNLIM	-40 to 85	HC125	<a href="#">Samples</a>
SN74HC125DT	ACTIVE	SOIC	D	14	250	Green (RoHS & no Sb/Br)	CU NIPDAU	Level-1-260C-UNLIM	-40 to 85	HC125	<a href="#">Samples</a>
SN74HC125N	ACTIVE	PDIP	N	14	25	Green (RoHS & no Sb/Br)	CU NIPDAU	N / A for Pkg Type	-40 to 85	SN74HC125N	<a href="#">Samples</a>
SN74HC125NE4	ACTIVE	PDIP	N	14	25	Green (RoHS & no Sb/Br)	CU NIPDAU	N / A for Pkg Type	-40 to 85	SN74HC125N	<a href="#">Samples</a>
SN74HC125NSR	ACTIVE	SO	NS	14	2000	Green (RoHS & no Sb/Br)	CU NIPDAU	Level-1-260C-UNLIM	-40 to 85	HC125	<a href="#">Samples</a>
SN74HC125NSRE4	ACTIVE	SO	NS	14	2000	Green (RoHS & no Sb/Br)	CU NIPDAU	Level-1-260C-UNLIM	-40 to 85	HC125	<a href="#">Samples</a>
SN74HC125NSRG4	ACTIVE	SO	NS	14	2000	Green (RoHS & no Sb/Br)	CU NIPDAU	Level-1-260C-UNLIM	-40 to 85	HC125	<a href="#">Samples</a>
SN74HC125PWR	ACTIVE	TSSOP	PW	14	2000	Green (RoHS & no Sb/Br)	CU NIPDAU   CU SN	Level-1-260C-UNLIM	-40 to 85	HC125	<a href="#">Samples</a>

Orderable Device	Status (1)	Package Type	Package Drawing	Pins	Package Qty	Eco Plan (2)	Lead/Ball Finish (6)	MSL Peak Temp (3)	Op Temp (°C)	Device Marking (4/5)	Samples
SN74HC125PWRE4	ACTIVE	TSSOP	PW	14	2000	Green (RoHS & no Sb/Br)	CU NIPDAU	Level-1-260C-UNLIM	-40 to 85	HC125	<a href="#">Samples</a>
SN74HC125PWRG4	ACTIVE	TSSOP	PW	14	2000	Green (RoHS & no Sb/Br)	CU NIPDAU	Level-1-260C-UNLIM	-40 to 85	HC125	<a href="#">Samples</a>
SN74HC125PWT	ACTIVE	TSSOP	PW	14	250	Green (RoHS & no Sb/Br)	CU NIPDAU	Level-1-260C-UNLIM	-40 to 85	HC125	<a href="#">Samples</a>
SNJ54HC125FK	ACTIVE	LCCC	FK	20	1	TBD	POST-PLATE	N / A for Pkg Type	-55 to 125	5962- 87721012A SNJ54HC 125FK	<a href="#">Samples</a>
SNJ54HC125J	ACTIVE	CDIP	J	14	1	TBD	A42	N / A for Pkg Type	-55 to 125	5962-8772101CA SNJ54HC125J	<a href="#">Samples</a>

(1) The marketing status values are defined as follows:

**ACTIVE:** Product device recommended for new designs.

**LIFEBUY:** TI has announced that the device will be discontinued, and a lifetime-buy period is in effect.

**NRND:** Not recommended for new designs. Device is in production to support existing customers, but TI does not recommend using this part in a new design.

**PREVIEW:** Device has been announced but is not in production. Samples may or may not be available.

**OBSOLETE:** TI has discontinued the production of the device.

(2) **RoHS:** TI defines "RoHS" to mean semiconductor products that are compliant with the current EU RoHS requirements for all 10 RoHS substances, including the requirement that RoHS substance do not exceed 0.1% by weight in homogeneous materials. Where designed to be soldered at high temperatures, "RoHS" products are suitable for use in specified lead-free processes. TI may reference these types of products as "Pb-Free".

**RoHS Exempt:** TI defines "RoHS Exempt" to mean products that contain lead but are compliant with EU RoHS pursuant to a specific EU RoHS exemption.

**Green:** TI defines "Green" to mean the content of Chlorine (Cl) and Bromine (Br) based flame retardants meet JS709B low halogen requirements of <=1000ppm threshold. Antimony trioxide based flame retardants must also meet the <=1000ppm threshold requirement.

(3) MSL, Peak Temp. - The Moisture Sensitivity Level rating according to the JEDEC industry standard classifications, and peak solder temperature.

(4) There may be additional marking, which relates to the logo, the lot trace code information, or the environmental category on the device.

(5) Multiple Device Markings will be inside parentheses. Only one Device Marking contained in parentheses and separated by a "~" will appear on a device. If a line is indented then it is a continuation of the previous line and the two combined represent the entire Device Marking for that device.

(6) Lead/Ball Finish - Orderable Devices may have multiple material finish options. Finish options are separated by a vertical ruled line. Lead/Ball Finish values may wrap to two lines if the finish value exceeds the maximum column width.

**Important Information and Disclaimer:** The information provided on this page represents TI's knowledge and belief as of the date that it is provided. TI bases its knowledge and belief on information provided by third parties, and makes no representation or warranty as to the accuracy of such information. Efforts are underway to better integrate information from third parties. TI has taken and continues to take reasonable steps to provide representative and accurate information but may not have conducted destructive testing or chemical analysis on incoming materials and chemicals. TI and TI suppliers consider certain information to be proprietary, and thus CAS numbers and other limited information may not be available for release.

In no event shall TI's liability arising out of such information exceed the total purchase price of the TI part(s) at issue in this document sold by TI to Customer on an annual basis.

**OTHER QUALIFIED VERSIONS OF SN54HC125, SN74HC125 :**

- Catalog: [SN74HC125](#)
- Automotive: [SN74HC125-Q1](#), [SN74HC125-Q1](#)
- Military: [SN54HC125](#)

NOTE: Qualified Version Definitions:

- Catalog - TI's standard catalog product
- Automotive - Q100 devices qualified for high-reliability automotive applications targeting zero defects
- Military - QML certified for Military and Defense Applications

**TAPE AND REEL INFORMATION**

**QUADRANT ASSIGNMENTS FOR PIN 1 ORIENTATION IN TAPE**

\*All dimensions are nominal

Device	Package Type	Package Drawing	Pins	SPQ	Reel Diameter (mm)	Reel Width W1 (mm)	A0 (mm)	B0 (mm)	K0 (mm)	P1 (mm)	W (mm)	Pin1 Quadrant
SN74HC125DR	SOIC	D	14	2500	330.0	16.4	6.5	9.0	2.1	8.0	16.0	Q1
SN74HC125DR	SOIC	D	14	2500	330.0	16.8	6.5	9.5	2.1	8.0	16.0	Q1
SN74HC125DRG4	SOIC	D	14	2500	330.0	16.4	6.5	9.0	2.1	8.0	16.0	Q1
SN74HC125DT	SOIC	D	14	250	330.0	16.4	6.5	9.0	2.1	8.0	16.0	Q1
SN74HC125PWR	TSSOP	PW	14	2000	330.0	12.4	6.9	5.6	1.6	8.0	12.0	Q1
SN74HC125PWR	TSSOP	PW	14	2000	330.0	12.4	6.9	5.6	1.6	8.0	12.0	Q1
SN74HC125PWRG4	TSSOP	PW	14	2000	330.0	12.4	6.9	5.6	1.6	8.0	12.0	Q1
SN74HC125PWT	TSSOP	PW	14	250	330.0	12.4	6.9	5.6	1.6	8.0	12.0	Q1

**TAPE AND REEL BOX DIMENSIONS**

\*All dimensions are nominal

Device	Package Type	Package Drawing	Pins	SPQ	Length (mm)	Width (mm)	Height (mm)
SN74HC125DR	SOIC	D	14	2500	367.0	367.0	38.0
SN74HC125DR	SOIC	D	14	2500	364.0	364.0	27.0
SN74HC125DRG4	SOIC	D	14	2500	367.0	367.0	38.0
SN74HC125DT	SOIC	D	14	250	210.0	185.0	35.0
SN74HC125PWR	TSSOP	PW	14	2000	367.0	367.0	35.0
SN74HC125PWR	TSSOP	PW	14	2000	364.0	364.0	27.0
SN74HC125PWRG4	TSSOP	PW	14	2000	367.0	367.0	35.0
SN74HC125PWT	TSSOP	PW	14	250	367.0	367.0	35.0

J 14

**GENERIC PACKAGE VIEW**  
**CDIP - 5.08 mm max height**  
CERAMIC DUAL IN LINE PACKAGE



Images above are just a representation of the package family, actual package may vary.  
Refer to the product data sheet for package details.

4040083-5/G

J0014A



# PACKAGE OUTLINE

CDIP - 5.08 mm max height

CERAMIC DUAL IN LINE PACKAGE



4214771/A 05/2017

**NOTES:**

1. All controlling linear dimensions are in inches. Dimensions in brackets are in millimeters. Any dimension in brackets or parenthesis are for reference only. Dimensioning and tolerancing per ASME Y14.5M.
2. This drawing is subject to change without notice.
3. This package is hermetically sealed with a ceramic lid using glass frit.
4. Index point is provided on cap for terminal identification only and on press ceramic glass frit seal only.
5. Falls within MIL-STD-1835 and GDIP1-T14.

# EXAMPLE BOARD LAYOUT

J0014A

CDIP - 5.08 mm max height

CERAMIC DUAL IN LINE PACKAGE



LAND PATTERN EXAMPLE  
NON-SOLDER MASK DEFINED  
SCALE: 5X



4214771/A 05/2017

D (R-PDSO-G14)

PLASTIC SMALL OUTLINE

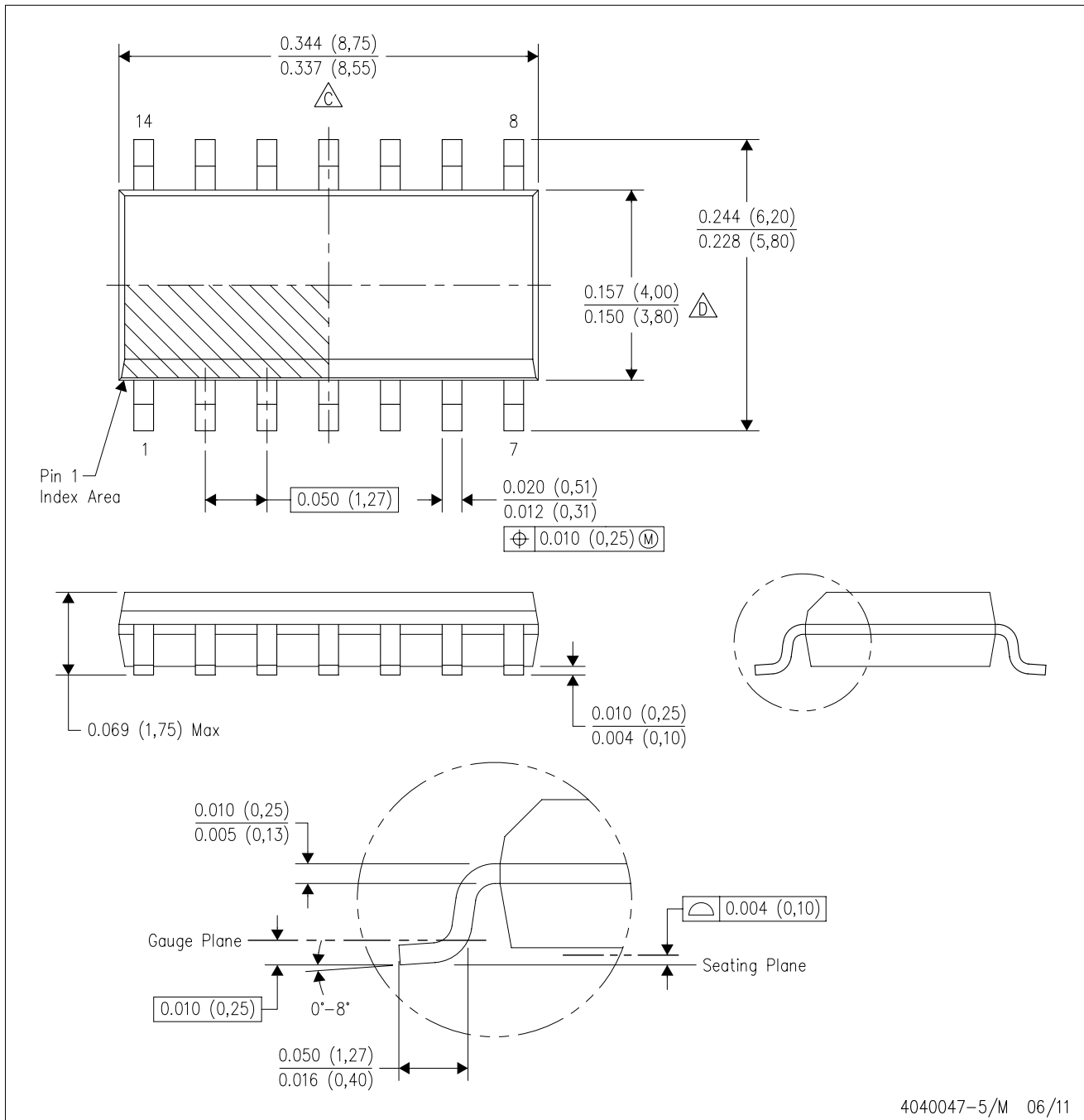

- NOTES:
- A. All linear dimensions are in inches (millimeters).
  - B. This drawing is subject to change without notice.
  - Body length does not include mold flash, protrusions, or gate burrs. Mold flash, protrusions, or gate burrs shall not exceed 0.006 (0,15) each side.
  - Body width does not include interlead flash. Interlead flash shall not exceed 0.017 (0,43) each side.
  - E. Reference JEDEC MS-012 variation AB.

D (R-PDSO-G14)

PLASTIC SMALL OUTLINE



- NOTES:
- All linear dimensions are in millimeters.
  - This drawing is subject to change without notice.
  - Publication IPC-7351 is recommended for alternate designs.
  - Laser cutting apertures with trapezoidal walls and also rounding corners will offer better paste release. Customers should contact their board assembly site for stencil design recommendations. Refer to IPC-7525 for other stencil recommendations.
  - Customers should contact their board fabrication site for solder mask tolerances between and around signal pads.



PW (R-PDSO-G14)

PLASTIC SMALL OUTLINE



4211284-2/G 08/15

- NOTES:
- A. All linear dimensions are in millimeters.
  - B. This drawing is subject to change without notice.
  - C. Publication IPC-7351 is recommended for alternate designs.
  - D. Laser cutting apertures with trapezoidal walls and also rounding corners will offer better paste release. Customers should contact their board assembly site for stencil design recommendations. Refer to IPC-7525 for other stencil recommendations.
  - E. Customers should contact their board fabrication site for solder mask tolerances between and around signal pads.

N (R-PDIP-T\*\*)

PLASTIC DUAL-IN-LINE PACKAGE

16 PINS SHOWN



- NOTES:
- A. All linear dimensions are in inches (millimeters).
  - B. This drawing is subject to change without notice.
  - Falls within JEDEC MS-001, except 18 and 20 pin minimum body length (Dim A).
  - The 20 pin end lead shoulder width is a vendor option, either half or full width.

DB (R-PDSO-G\*\*)

PLASTIC SMALL-OUTLINE

28 PINS SHOWN



- NOTES: A. All linear dimensions are in millimeters.  
 B. This drawing is subject to change without notice.  
 C. Body dimensions do not include mold flash or protrusion not to exceed 0,15.  
 D. Falls within JEDEC MO-150

FK (S-CQCC-N\*\*)

LEADLESS CERAMIC CHIP CARRIER

28 TERMINAL SHOWN

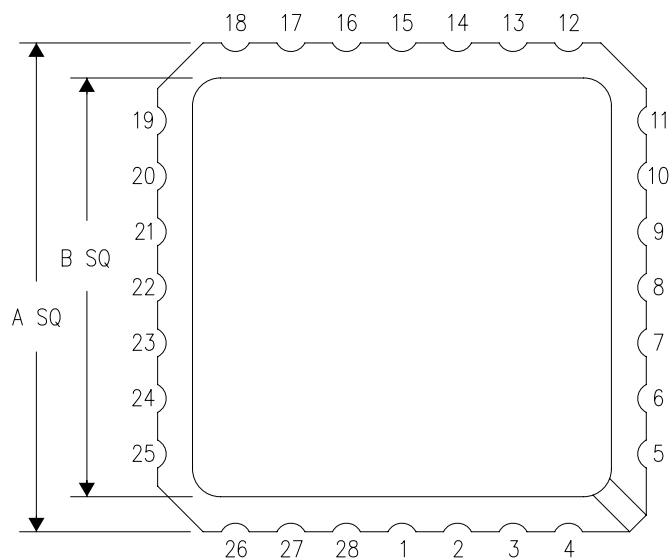

NO. OF TERMINALS **	A		B	
	MIN	MAX	MIN	MAX
20	0.342 (8,69)	0.358 (9,09)	0.307 (7,80)	0.358 (9,09)
28	0.442 (11,23)	0.458 (11,63)	0.406 (10,31)	0.458 (11,63)
44	0.640 (16,26)	0.660 (16,76)	0.495 (12,58)	0.560 (14,22)
52	0.740 (18,78)	0.761 (19,32)	0.495 (12,58)	0.560 (14,22)
68	0.938 (23,83)	0.962 (24,43)	0.850 (21,6)	0.858 (21,8)
84	1.141 (28,99)	1.165 (29,59)	1.047 (26,6)	1.063 (27,0)



4040140/D 01/11

- NOTES:
- All linear dimensions are in inches (millimeters).
  - This drawing is subject to change without notice.
  - This package can be hermetically sealed with a metal lid.
  - Falls within JEDEC MS-004

# MECHANICAL DATA

NS (R-PDSO-G\*\*)

PLASTIC SMALL-OUTLINE PACKAGE

14-PINS SHOWN



- NOTES:
- A. All linear dimensions are in millimeters.
  - B. This drawing is subject to change without notice.
  - C. Body dimensions do not include mold flash or protrusion, not to exceed 0,15.

## IMPORTANT NOTICE AND DISCLAIMER

TI PROVIDES TECHNICAL AND RELIABILITY DATA (INCLUDING DATASHEETS), DESIGN RESOURCES (INCLUDING REFERENCE DESIGNS), APPLICATION OR OTHER DESIGN ADVICE, WEB TOOLS, SAFETY INFORMATION, AND OTHER RESOURCES "AS IS" AND WITH ALL FAULTS, AND DISCLAIMS ALL WARRANTIES, EXPRESS AND IMPLIED, INCLUDING WITHOUT LIMITATION ANY IMPLIED WARRANTIES OF MERCHANTABILITY, FITNESS FOR A PARTICULAR PURPOSE OR NON-INFRINGEMENT OF THIRD PARTY INTELLECTUAL PROPERTY RIGHTS.

These resources are intended for skilled developers designing with TI products. You are solely responsible for (1) selecting the appropriate TI products for your application, (2) designing, validating and testing your application, and (3) ensuring your application meets applicable standards, and any other safety, security, or other requirements. These resources are subject to change without notice. TI grants you permission to use these resources only for development of an application that uses the TI products described in the resource. Other reproduction and display of these resources is prohibited. No license is granted to any other TI intellectual property right or to any third party intellectual property right. TI disclaims responsibility for, and you will fully indemnify TI and its representatives against, any claims, damages, costs, losses, and liabilities arising out of your use of these resources.

TI's products are provided subject to TI's Terms of Sale ([www.ti.com/legal/termsofsale.html](http://www.ti.com/legal/termsofsale.html)) or other applicable terms available either on [ti.com](http://ti.com) or provided in conjunction with such TI products. TI's provision of these resources does not expand or otherwise alter TI's applicable warranties or warranty disclaimers for TI products.

Mailing Address: Texas Instruments, Post Office Box 655303, Dallas, Texas 75265  
Copyright © 2019, Texas Instruments Incorporated

## Looking for pricing, stock, or lifecycle information?

Click below to explore more details on WIN SOURCE:

 [View SN74HC125DRG4 on WIN SOURCE](#)

 [Texas Instruments](#) Information

## Optimize Your Supply Chain with WIN SOURCE Solutions

-  Global Sourcing Solution
-  Obsolete Management
-  Cost Control Management
-  Shortage Management
-  Alternative Solution
-  Excess Inventory Management