



**THE DATASHEET OF  
BD91364BMUU-ZE2**



# 2.9V to 5.5V Input, 5A Integrated MOSFET Single Synchronous Buck DC/DC Converter

## BD91364BMUU

### General Description

ROHM's high efficiency switching regulator, BD91364BMUU, is a step-down converter designed to produce a low voltage output of 0.8V to 3.3V from a 2.9V to 5.5V power supply line. It offers high efficiency in all load ranges by automatic PFM/PWM adjustment. It employs an On-time control system to provide faster transient response to sudden change in load.

### Features

- Fast transient response with On-time control system.
- High efficiency for all load range with synchronous rectifier (Nch/Nch FET) and adaptive PFM/PWM system.
- Adjustable Soft-start function.
- Thermal and UVLO protection.
- Short-circuit current protection with timer latch.
- Shutdown function.

### Applications

- Power supply for LSI including SoC, DSP, Micro computer and ASIC
- Laptop PC / Tablet PC / Server
  - LCD TV, Storage Devices (HDD / SSD)
  - Printer
  - Entertainment device
  - Secondary power supply

### Key Specifications

- Input Voltage Range: 2.9V to 5.5V
- Output Voltage Range: 0.8V to PVCC×0.8V
- Output Current: 5.0A(Max)
- Switching Frequency: 1.7MHz(Typ)
- High Side FET ON Resistance: 27mΩ(Typ)
- Low Side FET ON Resistance: 27mΩ(Typ)
- Standby Current: 0μA (Typ)
- Operating Temperature Range: -40°C to +105°C

### Package

VQFN20U4040M

W(Typ) x D(Typ) x H(Max)  
4.00mm x 4.00mm x 0.50mm

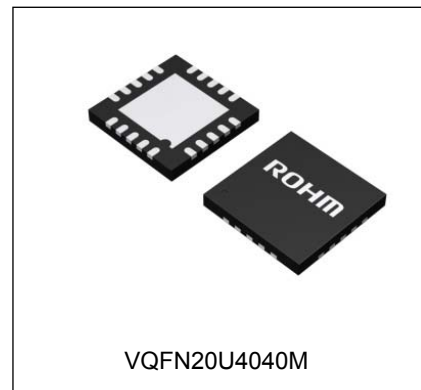

### Typical Application Circuit

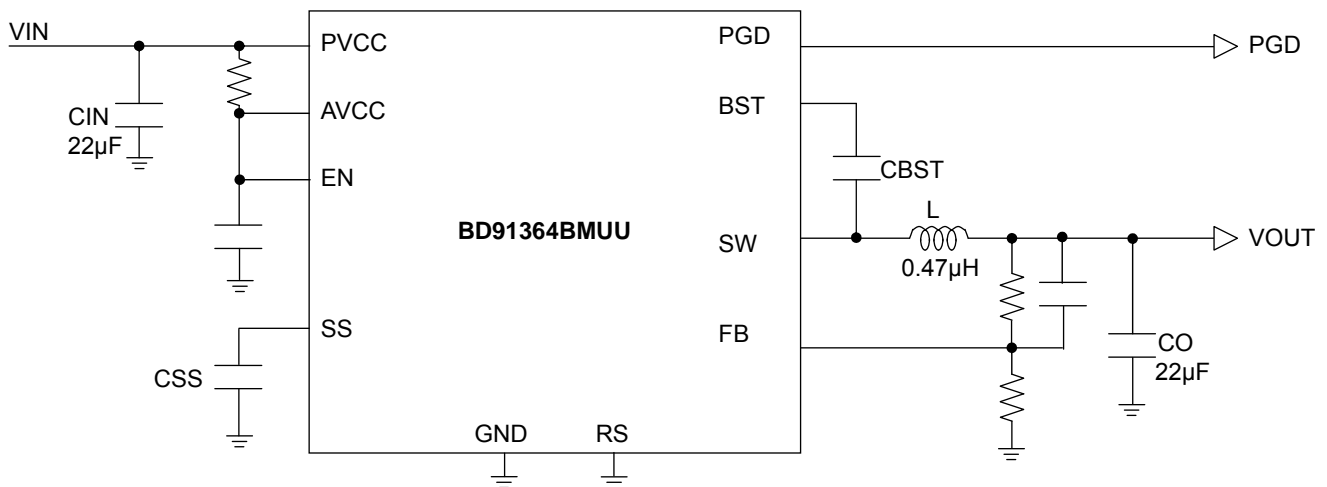

Figure 1. Typical Application Circuit

Pin Configuration(TOP VIEW)

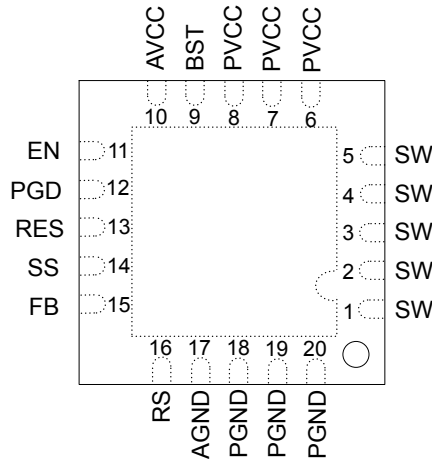

Figure 2. Pin Configuration

Pin Description

Pin No.	Pin Name	Function	Pin No.	Pin Name	Function
1	SW	Switch pin	11	EN	Enable pin (High active)
2	SW	Switch pin	12	PGD	Power good open drain pin
3	SW	Switch pin	13	RES	Reserve pin, Connect to ground
4	SW	Switch pin	14	SS	Soft start capacitor connection pin
5	SW	Switch pin	15	FB	Output voltage detect pin
6	PVCC	High Side FET source pin	16	RS	Remote sense ground pin
7	PVCC	High Side FET source pin	17	AGND	Ground
8	PVCC	High Side FET source pin	18	PGND	Low Side FET source pin
9	BST	Bootstrapped voltage input pin	19	PGND	Low Side FET source pin
10	AVCC	Power supply input pin	20	PGND	Low Side FET source pin

Block Diagram

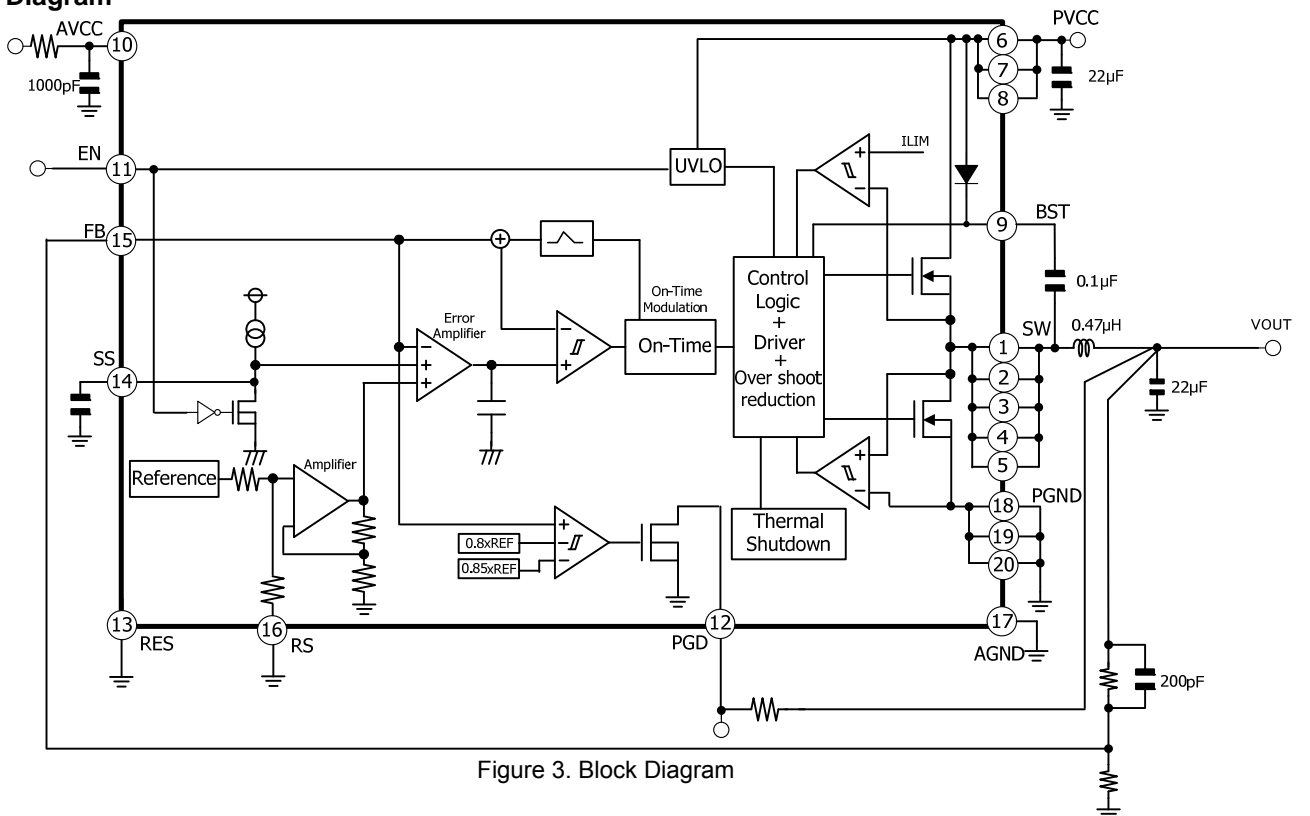

Figure 3. Block Diagram

**Absolute Maximum Ratings (Ta= 25°C)**

Parameter	Symbol	Rating	Unit
AVCC/ PVCC Voltage	AVCC/PVCC	-0.3 to +7 <sup>(Note 1)</sup>	V
EN Voltage	VEN	-0.3 to +7 <sup>(Note 1)</sup>	V
BST Voltage	VBST	-0.3 to +13	V
BST_SW Voltage	VBST-SW	-0.3 to +7	V
SW Voltage	VSW	-0.3 to +7	V
SS/FB/PGD/RS Voltage	VSS/ VFB VPGD/ VRS	-0.3 to +7	V
Power Dissipation 1	Pd1	0.8 <sup>(Note 2)</sup>	W
Power Dissipation 2	Pd2	1.7 <sup>(Note 3)</sup>	W
Power Dissipation 3	Pd3	2.7 <sup>(Note 4)</sup>	W
Operating temperature range	Topr	-40 to +105	°C
Storage temperature range	Tstg	-55 to +150	°C
Maximum junction temperature	Tjmax	+150	°C

(Note 1) Pd, and Tj=150°C should not be exceeded.

(Note 2) 1-layer. mounted on a 74.2mm x 74.2mm x 1.6mmt glass-epoxy board, occupied area by copper foil : 0mm<sup>2</sup>

(Note 3) 2-layer. mounted on a 74.2mm x 74.2mm x 1.6mmt glass-epoxy board, occupied area by copper foil : 5505mm<sup>2</sup>, in each layers.

(Note 4) 4-layer. mounted on a 74.2mm x 74.2mm x 1.6mmt glass-epoxy board, occupied area by copper foil : 5505mm<sup>2</sup>, in each layers.

**Recommended Operating Conditions (Ta= -40°C to +105°C)**

Parameter	Symbol	Min	Typ	Max	Unit
Power Supply Voltage	AVCC	2.9	5.0	5.5	V
	PVCC	2.9	5.0	5.5	V
EN Voltage	VEN	0	VCC	5.5	V
Output Voltage Range	VOUT	0.8	-	PVCC×0.8	V
SW Average Output Current	ISW	-	-	5 <sup>(Note 5)</sup>	A

(Note 5) Pd should not be exceeded.

**Electrical Characteristics**

(Unless otherwise specified Ta= 25°C AVCC=PVCC=5V, EN=VCC, R1=200kΩ, R2=51kΩ)

Parameter	Symbol	Min	Typ	Max	Unit	Conditions
AVCC and PVCC Voltage Range	VIN	2.9	-	5.5	V	
Standby Supply Current	ISTB	-	-	3	μA	EN=GND
Operating Supply Current	ICC	100	150	200	μA	Non-switching
UVLO Threshold Voltage	VUVLO1	2.650	2.750	2.850	V	VCC rising
UVLO Release Voltage	VUVLO2	2.450	2.550	2.650	V	VCC falling
<b>Enable</b>						
EN Low-level Input Voltage	VENL	GND	-	0.8	V	Standby mode
EN High-level Input Voltage	VENH	1.8	-	V <sub>CC</sub>	V	Active mode
EN Input Current	IEN	-	3	6	μA	VEN=5V
<b>Power GOOD</b>						
PG Threshold Voltage	VPGTH	-20%	-15%	-10%	V	VFB-15% (Typ)
PG Hysteresis Voltage	VPGHYS	-25%	-20%	-15%	V	VFB-20% (Typ)
PG Detect Delay Time	PDELAY	6	15	25	μs	
Open Drain Output Resistance	RPG	50	100	200	Ω	VFB < VPGTH
PG Leakage Current	IPL	-	-	1	μA	VPG=5V
<b>Power Switch</b>						
High Side FET ON Resistance	RONH	-	27	50	mΩ	PVCC=5V
Low Side FET ON Resistance	RONL	-	27	50	mΩ	PVCC=5V
On-Time	TON	94	118	142	ns	VCC=5V, VOUT=1.0V, PWM
<b>Soft Start</b>						
Soft Start Time	TSS	0.45	1	2	ms	Internal
Soft Start Charge Current	ISS	0.5	1.2	1.8	μA	
<b>Output</b>						
Voltage Reference Accuracy	VFB	0.788	0.800	0.812	V	
Remote Sense Detect Voltage Range	VRS	0	-	100	mV	

Typical Performance Curves

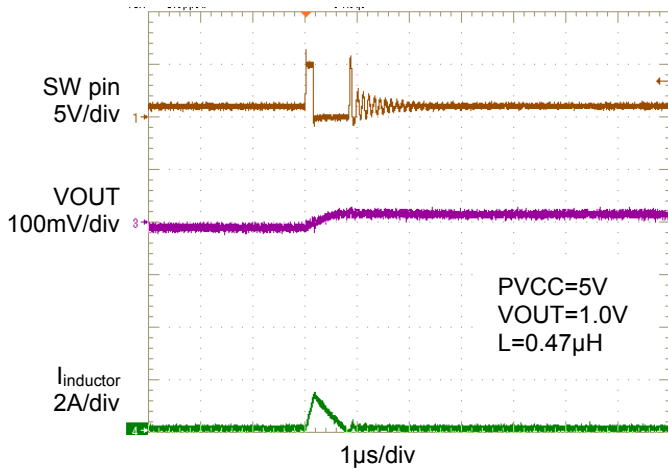

Figure 4. PFM operation, load 0mA

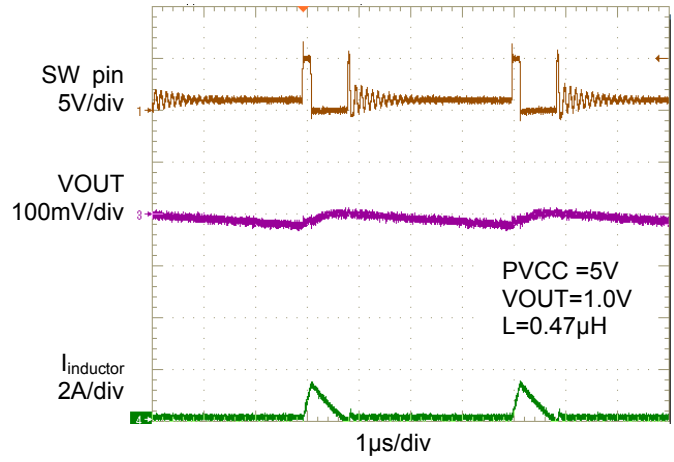

Figure 5. PFM operation, load 100mA

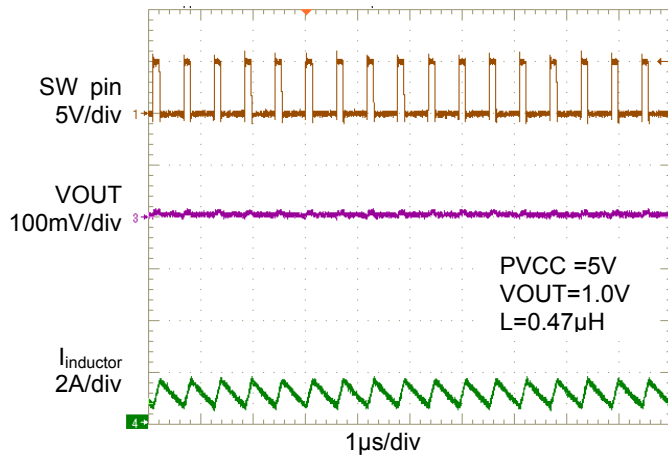

Figure 6. PWM operation, load 1000mA

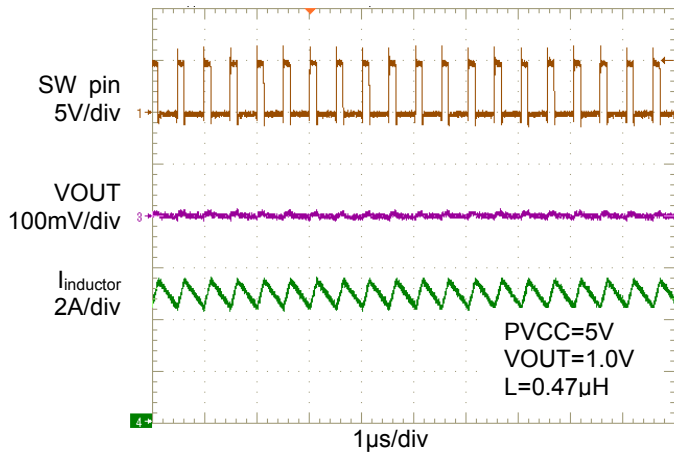

Figure 7. PWM operation, load 5000mA

Typical Performance Curves - continued

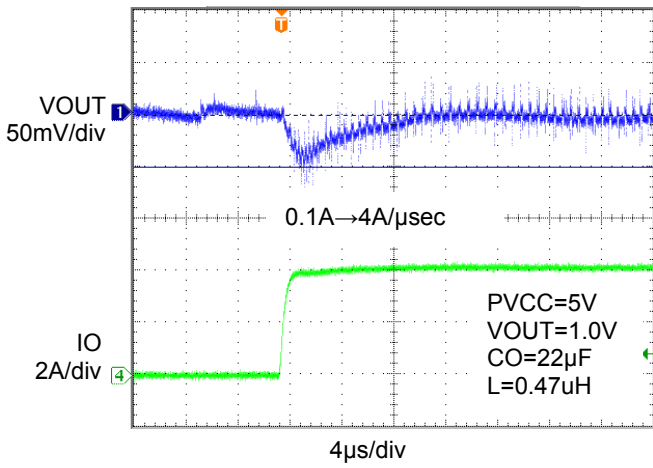

Figure 8. 0.1A to 4A Load transient response

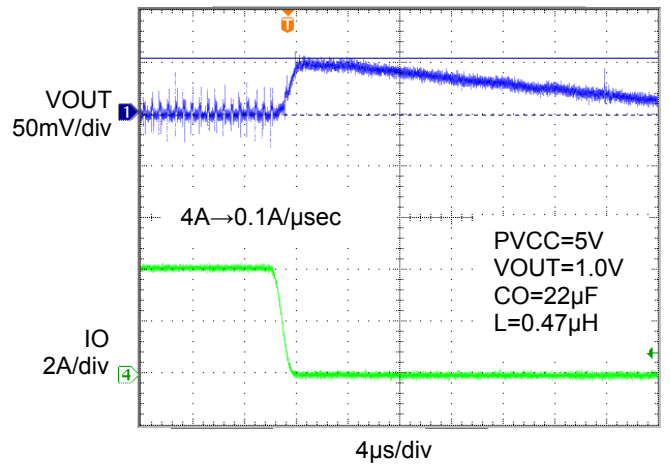

Figure 9. 4A to 0.1A Load transient response

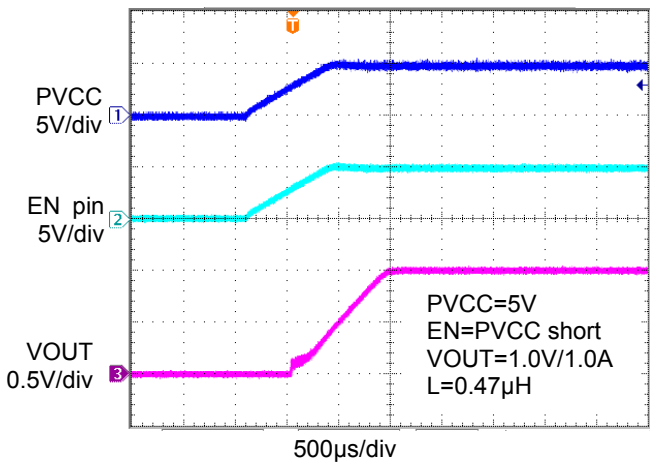

Figure 10. Start-up with PVCC

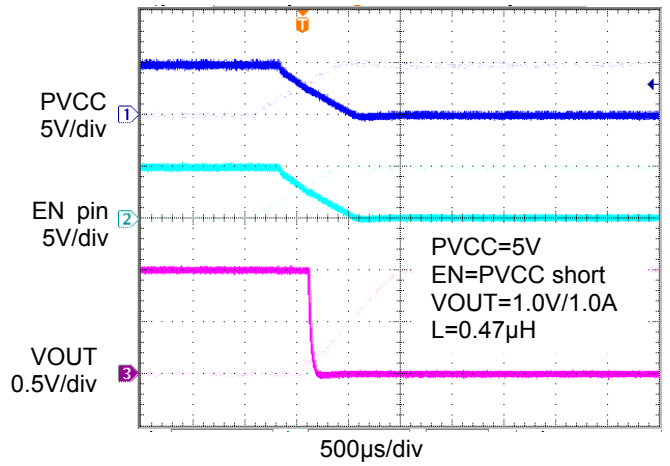

Figure 11. Shutdown with PVCC

Typical Performance Curves - continued

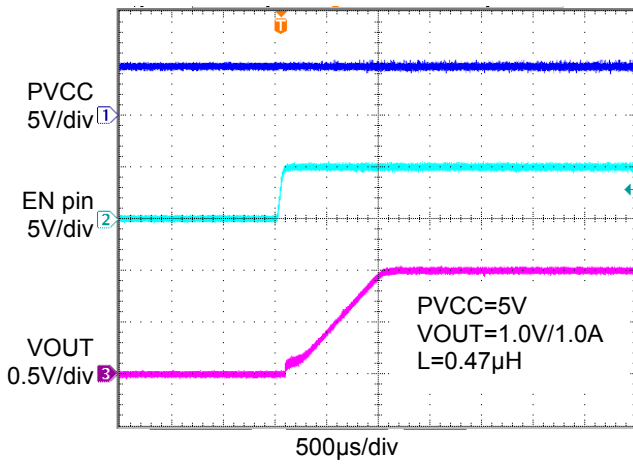

Figure 12. Start-up with EN

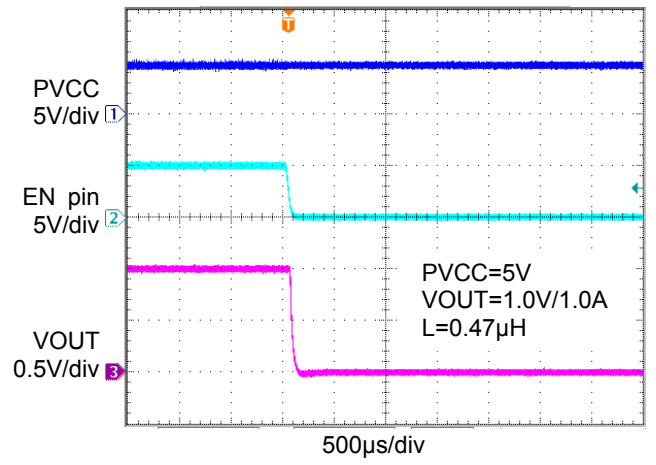

Figure 13. Shutdown with EN

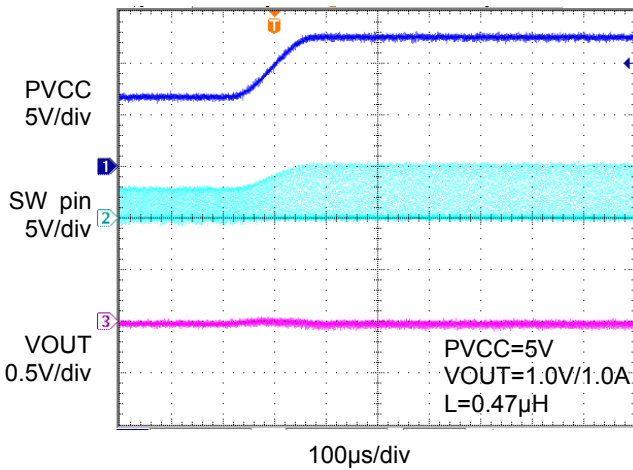

Figure 14. PVCC variation 2.9V to 5.5V

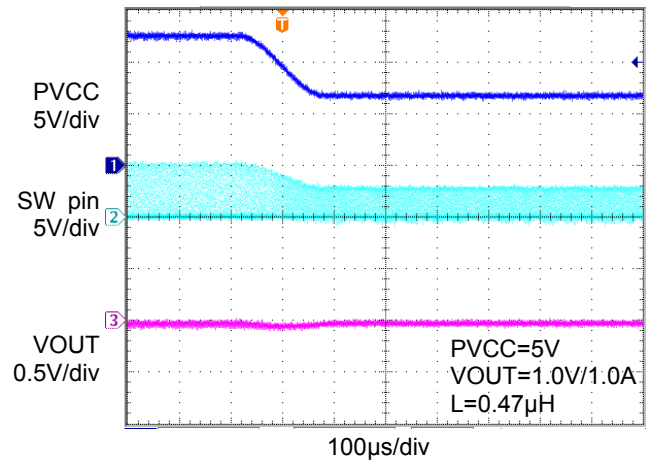

Figure 15. PVCC variation 5.5V to 2.9V

Typical Performance Curves - continued

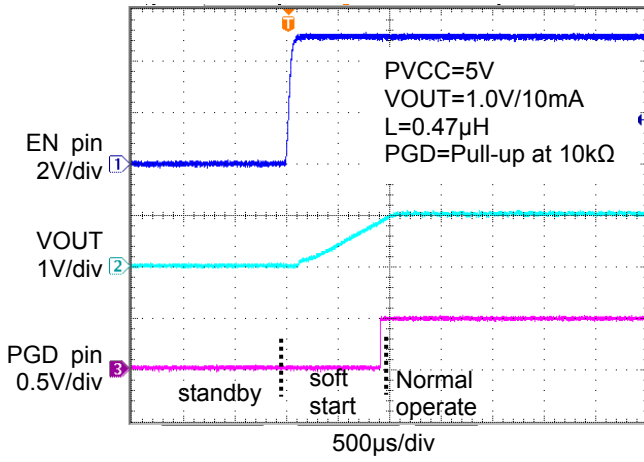

Figure 16. Power Good (Start-up)

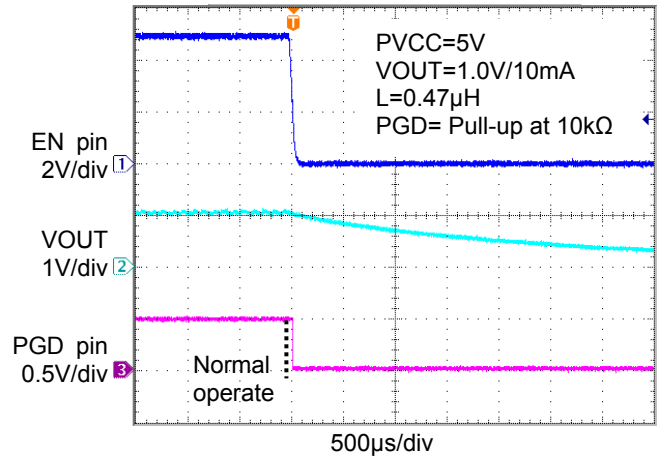

Figure 17. Power Good (Shutdown)

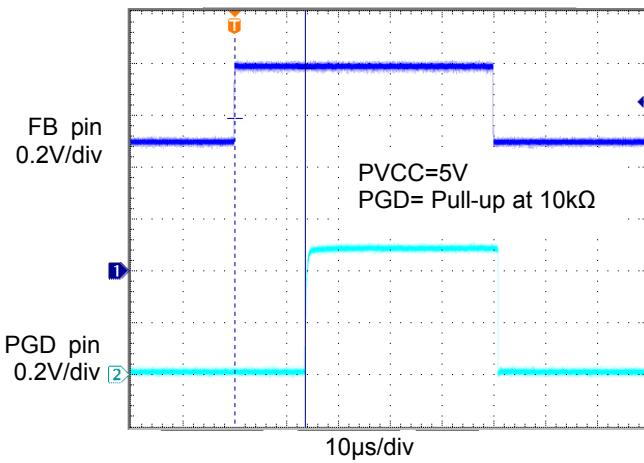

Figure 18. Power Good delay

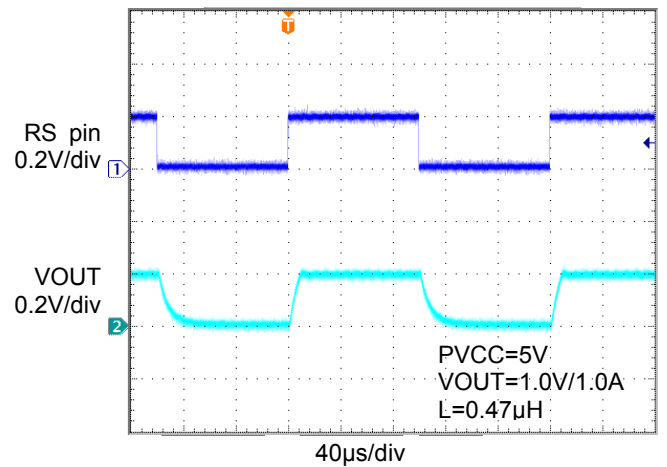

Figure 19. Remote sense function

Typical Performance Curves - continued

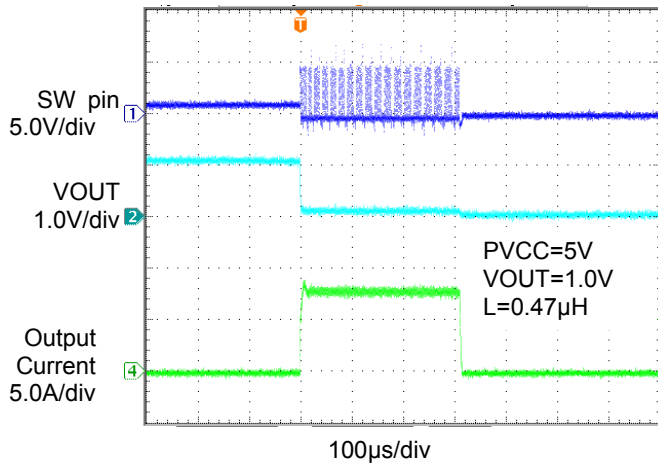

Figure 20. Output ground fault

Typical Performance Curves - continued

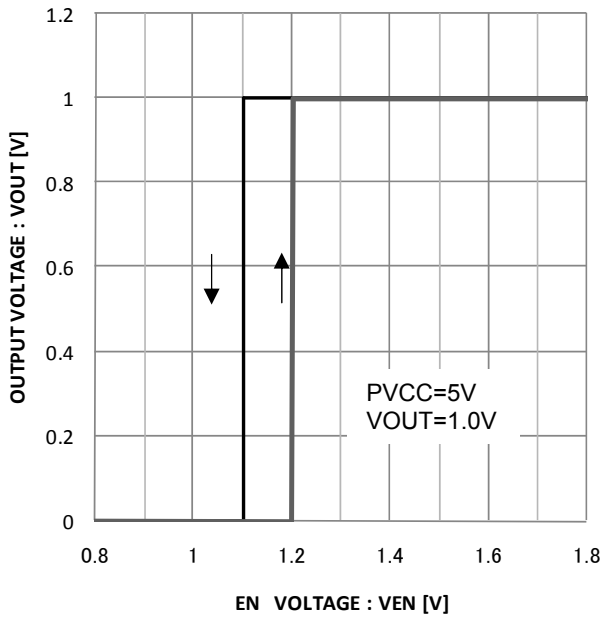

Figure 21. EN start-up

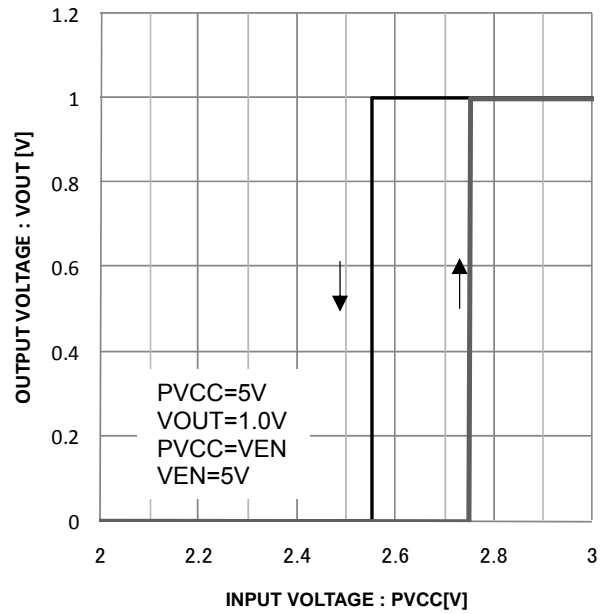

Figure 22. PVCC start-up

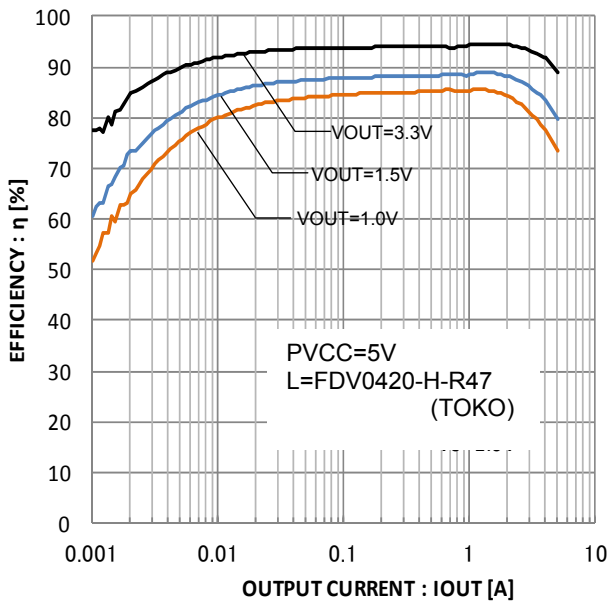

Figure 23. Efficiency

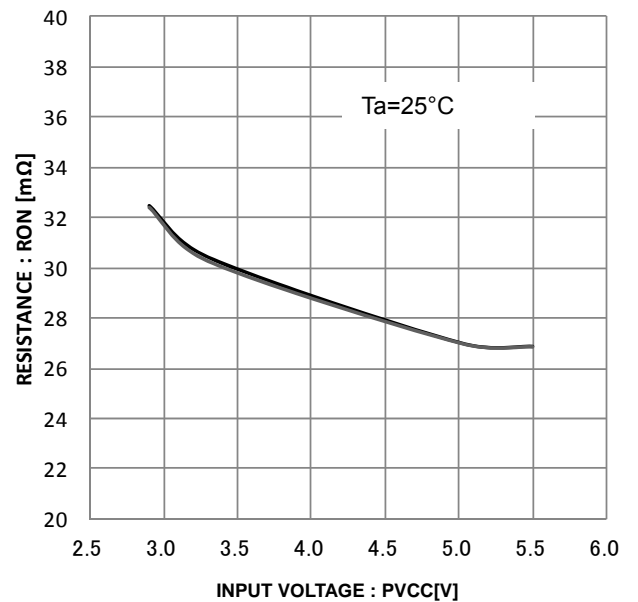

Figure 24. Power MOSFET On-resistor

Typical Performance Curves - continued

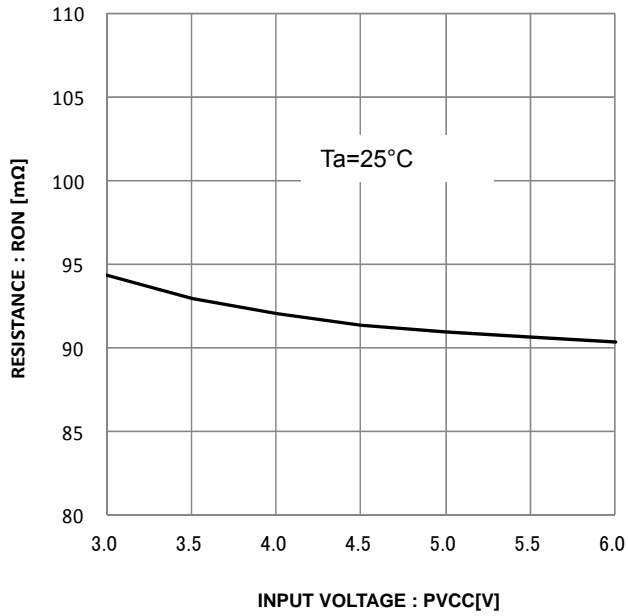

Figure 25. PowerGood MOSFET On-resistor

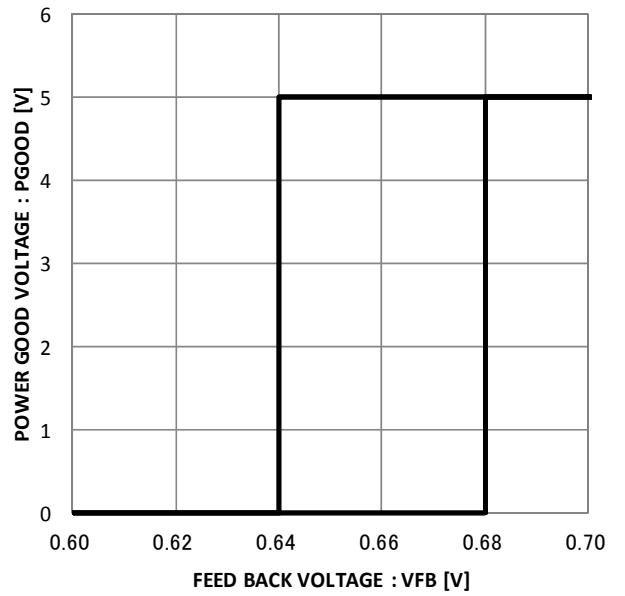

Figure 26. PowerGood voltage/hysteresis

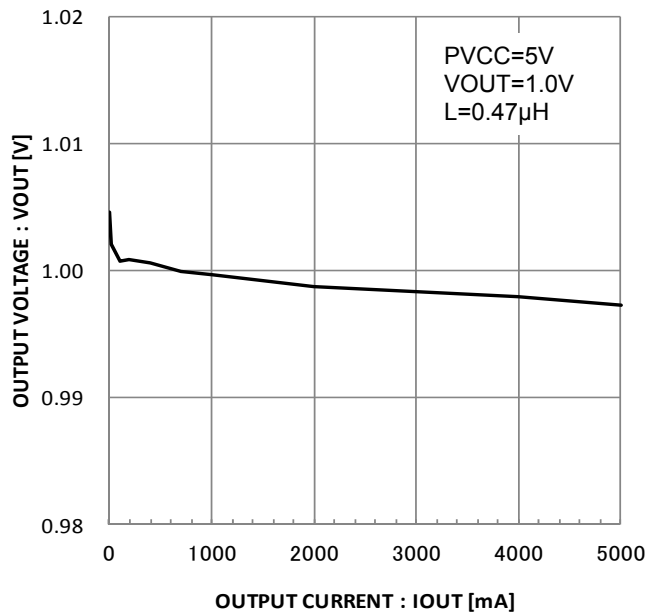

Figure 27. Output variation (Load regulation)

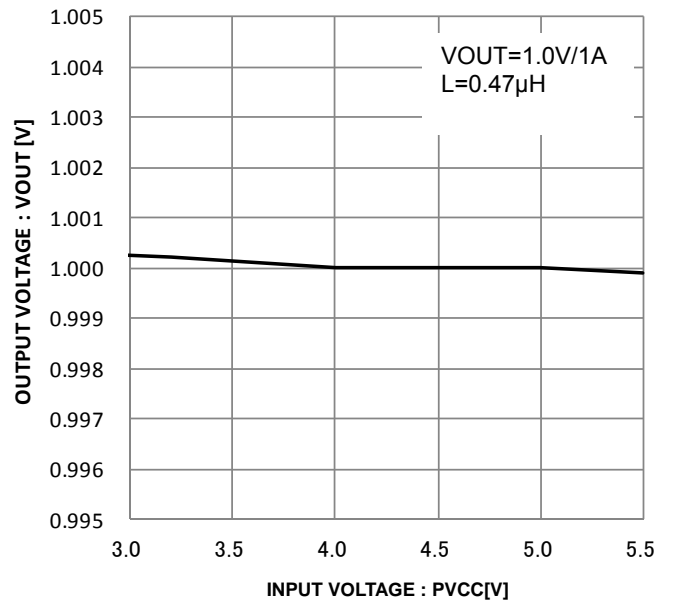

Figure 28. Output variation (Line regulation)

Typical Performance Curves - continued

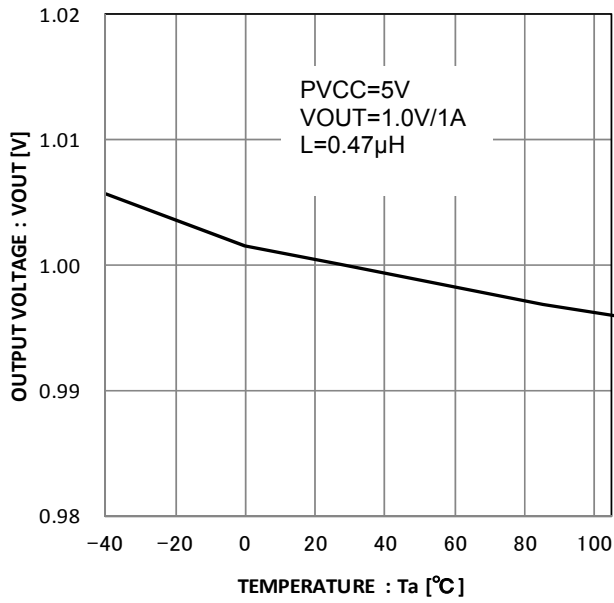

Figure 29. Output variation (ambient temperature)

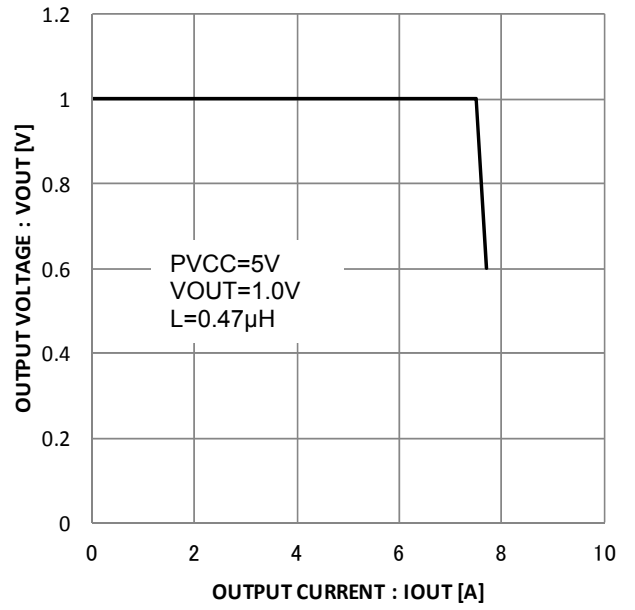

Figure 30. OCP detection current

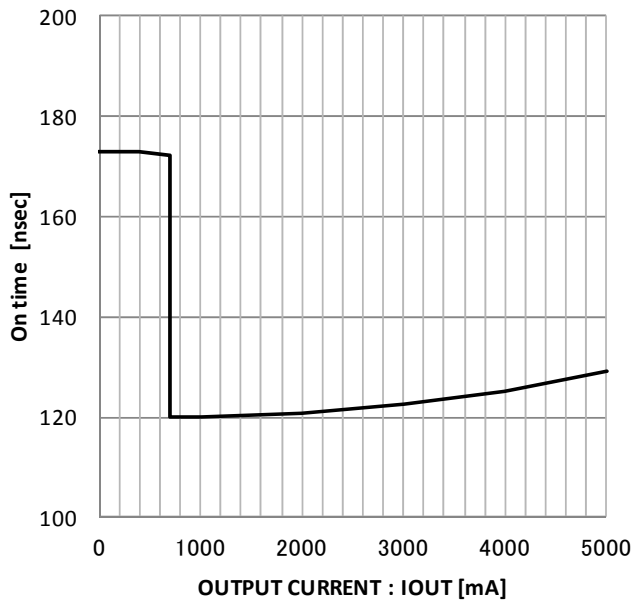

Figure 31. On-time variation (Load regulation)

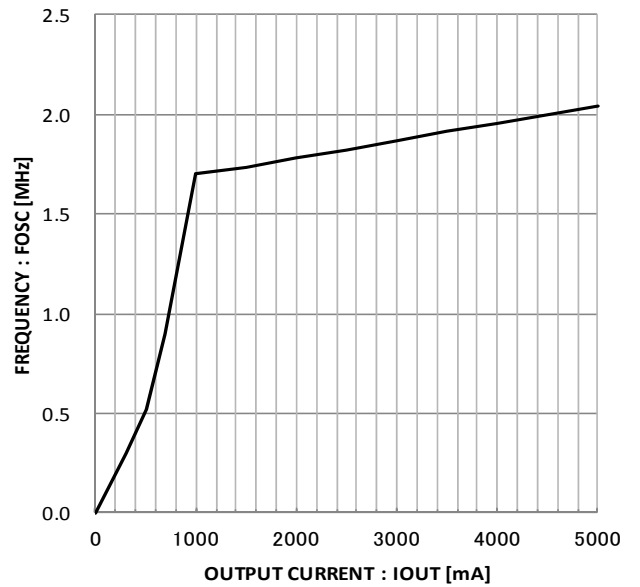

Figure 32. Frequency variation (Load regulation)

## Application Information

### Operation

BD91364BMUU is a buck synchronous rectification switching regulator capable of high speed transient response by implementing a constant On-Time system as its hysteresis control. General hysteresis control systems need a certain ripple to give an output voltage. Furthermore, a high ESR output capacitor is needed to maintain appropriate switching control.

BD91364BMUU has a ripple implanted system at output detection which keeps a normal switching operation even if a low ESR output capacitor is used. This feature also resolved a weakness of a regular hysteresis control, which is, to keep a steady frequency from a variation of frequencies.

When operating with light loads, BD91364BMUU reduce switching loss and attain high efficiency by utilizing a pulse skip system.

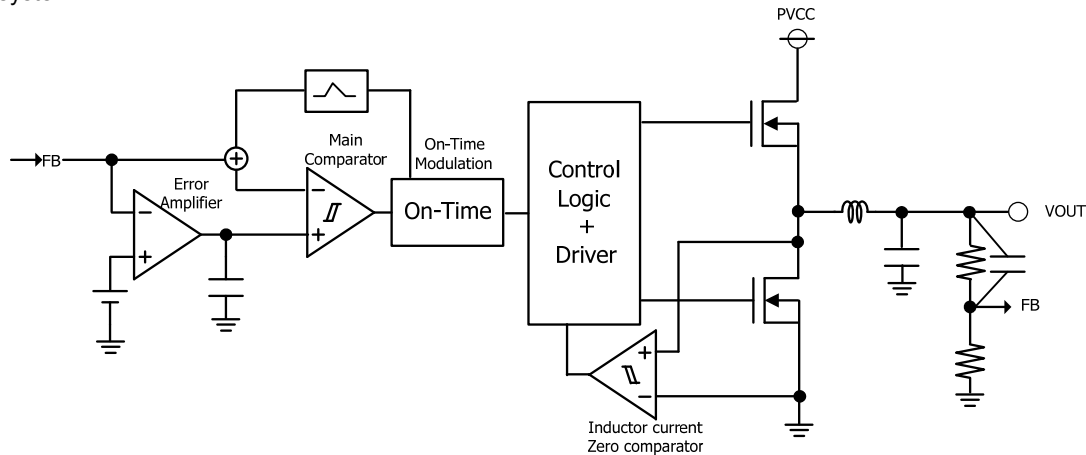

Figure 33. Constant on-time system block diagram

## Description of Operations

### 1. Soft Start Function

When EN terminal is shifted to "High", it activates a soft-start function which gradually raises the output voltage while limiting the current at startup. This prevents an overshoot in output voltage by preventing start-up in-rush current.

Rise time is dependent on capacitor CSS connected to SS pin.

$$TSS = (CSS \times VFB) / ISS \quad [\text{sec}]$$

$TSS$  : Soft-start time

$CSS$  : Capacitor connected to Soft-start pin

$VFB$  : FB Voltage 0.8V (Typ)

$ISS$  : Source current at Soft-start pin 1.2 $\mu$ A (Typ)

Ex.) When  $CSS=0.01\mu\text{F}$

$$TSS = (0.01 [\mu\text{F}] \times 0.8 [\text{V}]) / 1.2 [\mu\text{A}]$$

$$= 6.67 \quad [\text{msec}]$$

If EN terminal is shifted to "High" when capacitor CSS is not connected, SS pin is OPEN or in "High" condition, the output voltage will rise in 1msec (Typ).

### 2. Shutdown Function

With EN terminal shifted to "Low", the device turns to Standby Mode. All functional blocks including reference voltage circuit, internal oscillator and drivers are turned OFF. Circuit current during standby is 0 $\mu$ A (Typ).

3. UVLO Function

UVLO detects whether the input voltage is sufficient to secure a desired IC output voltage. A hysteresis width of 200mV (Typ) is provided to prevent output chattering.

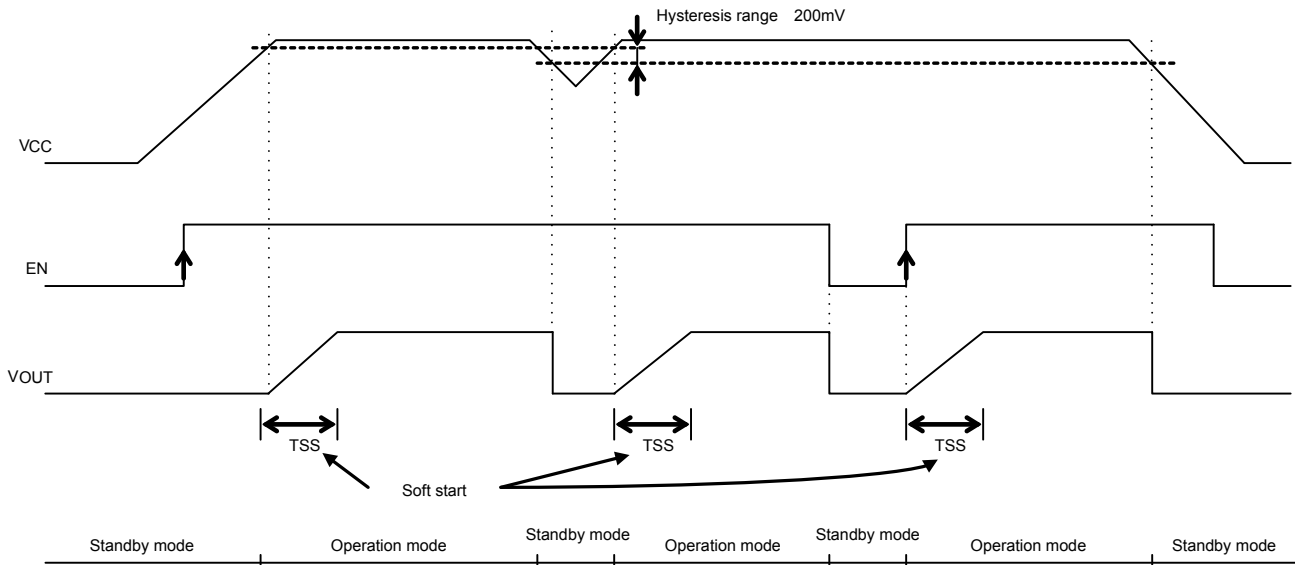

Figure 34. Soft Start, Shutdown, UVLO timing chart

4. Power-good function

When FB terminal voltage falls below 80%(0.64V) of the internal reference voltage, an open drain MOS which is internally connected to PGD terminal turns ON. This event pulls down the PGD terminal with a 100Ω(Typ) impedance. When FB terminal voltage reaches 85%(0.68V) of the internal reference voltage, PGD terminal will enter a high impedance state after 15μsec delay. This terminal is an open drain output so a pull up resistor is needed for proper operation.

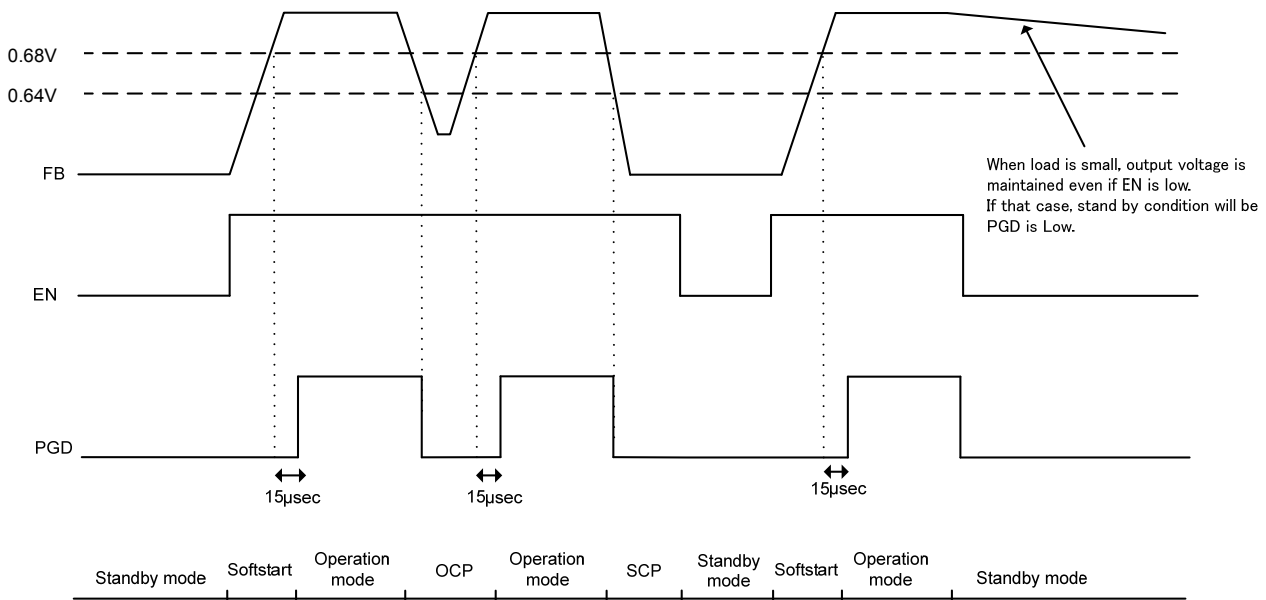

Figure 35. Power-good timing chart

5. Over Current Protection Function/Pulse Count Short-Circuit Protection

Over current detection circuit is operating when the high side MOS is ON. When over current is detected, On/Off duty will be controlled to decrease the output voltage. If over current is still present 1024 counts after output voltage falls below 80% of the set voltage (Power Good error), the output will be latched in OFF state to prevent IC damage. Output is returned by resetting EN or releasing UVLO again.

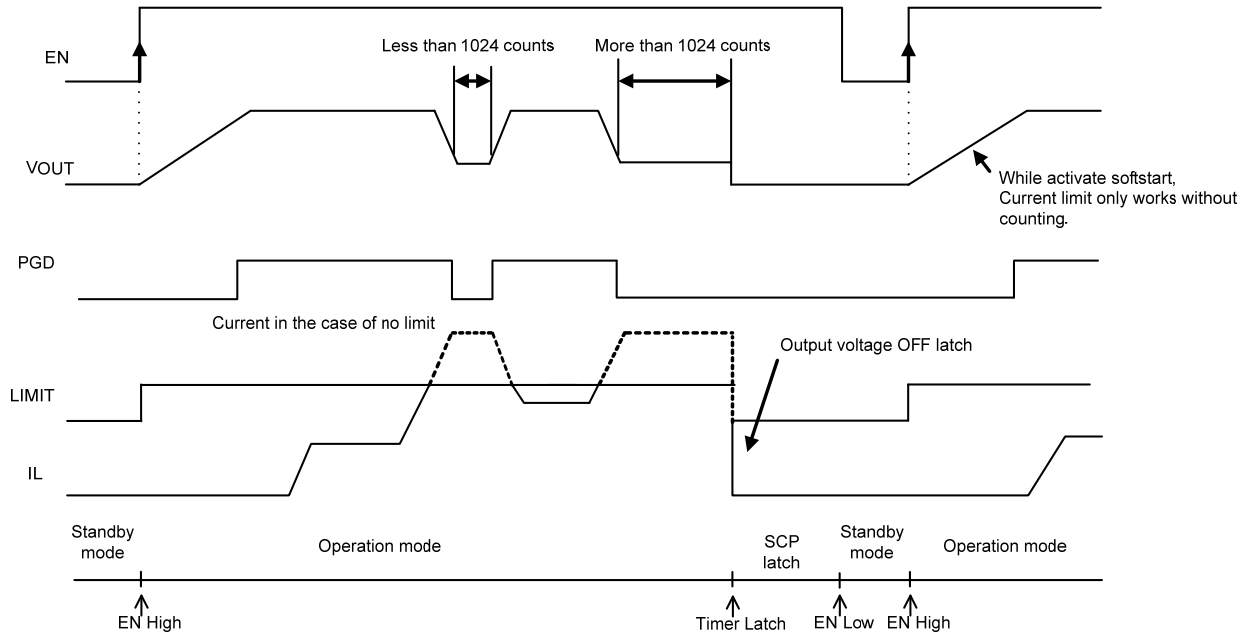

Figure 36. Over current protection/short-circuit protection function timing chart

6. Over Shoot Reduction (load responsiveness characteristic improvement function)

Output voltage rises when load current is decreased rapidly. Normally, LG control signal is kept on turning ON and the gradient of coil current  $\Delta I_L$  will be  $\Delta I_L = -V_{OUT}/L$ . At this point, if slew rate,  $\Delta I_{OUT}$ , of load current  $I_{OUT}$  will be  $\Delta I_{OUT} > \Delta I_L$ , excess current will be charged and output voltage will keep on rising (Fig.37 dotted line waveform). When the output voltage is set to a low value,  $\Delta I_L$  will be small and output voltage will increase significantly. BD91364BMUU operates over shoot reduction when the Low side power MOS is kept ON after twice the PWM pulse width.  $V_f$  voltage is generated to the SW terminal by turning off the HG-LG and applying  $I_L$  through the body diode of the Lowside MOS. This makes  $\Delta I_L = (-V_f - V_{OUT})/L$  and reduces the rise in output voltage by controlling excess current not to be charged to output capacitor.

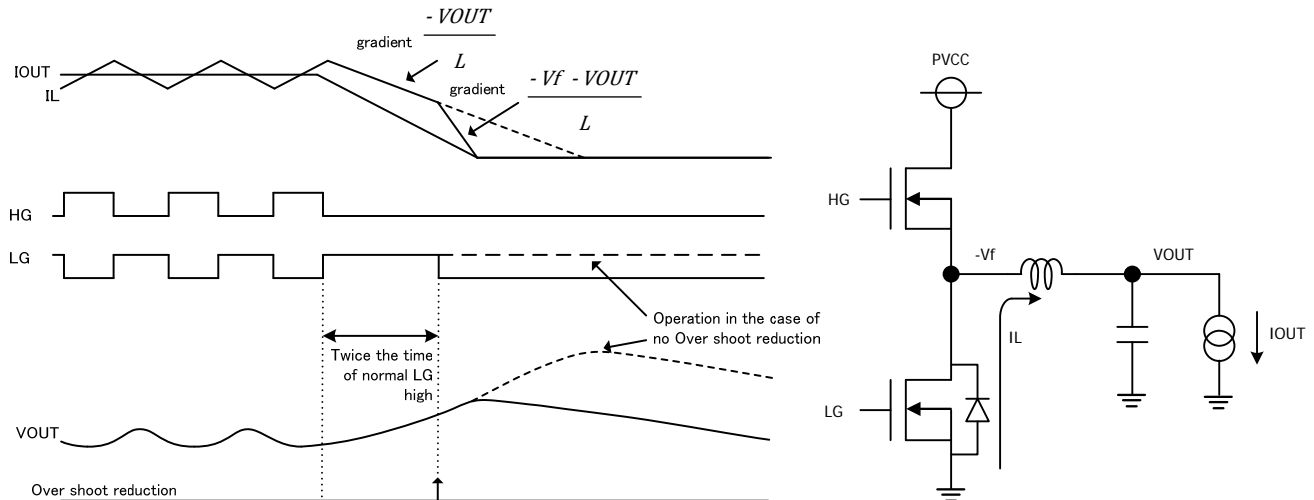

Figure 37. Over short reduction timing chart

7. Remote Sense

Voltage drop is caused by an interconnection resistance,  $R_x$ , present between the power supply IC output,  $V_{OUT}$ , and the load, such as a System on a Chip (SoC). In addition,  $GNDS$  terminal can get to a higher potential by an interconnection resistance  $R_y$  between board GND and  $GNDS$  terminal of SoC. This voltage variation increases in proportion to the load current and may cause SoC malfunction.

BD91364BMUU remote circuit, as shown in Fig.38, compensates voltage variation caused by  $R_y$ . The voltage in between  $VS$  and  $GND$  is kept constant by sensing the voltage at  $GNDS$  terminal and adding it to the IC's reference voltage.

As for interconnection resistance  $R_x$ , voltage variation can be prevented by monitoring the output voltage feedback line from the nearest SoC input terminal,  $VS$ .

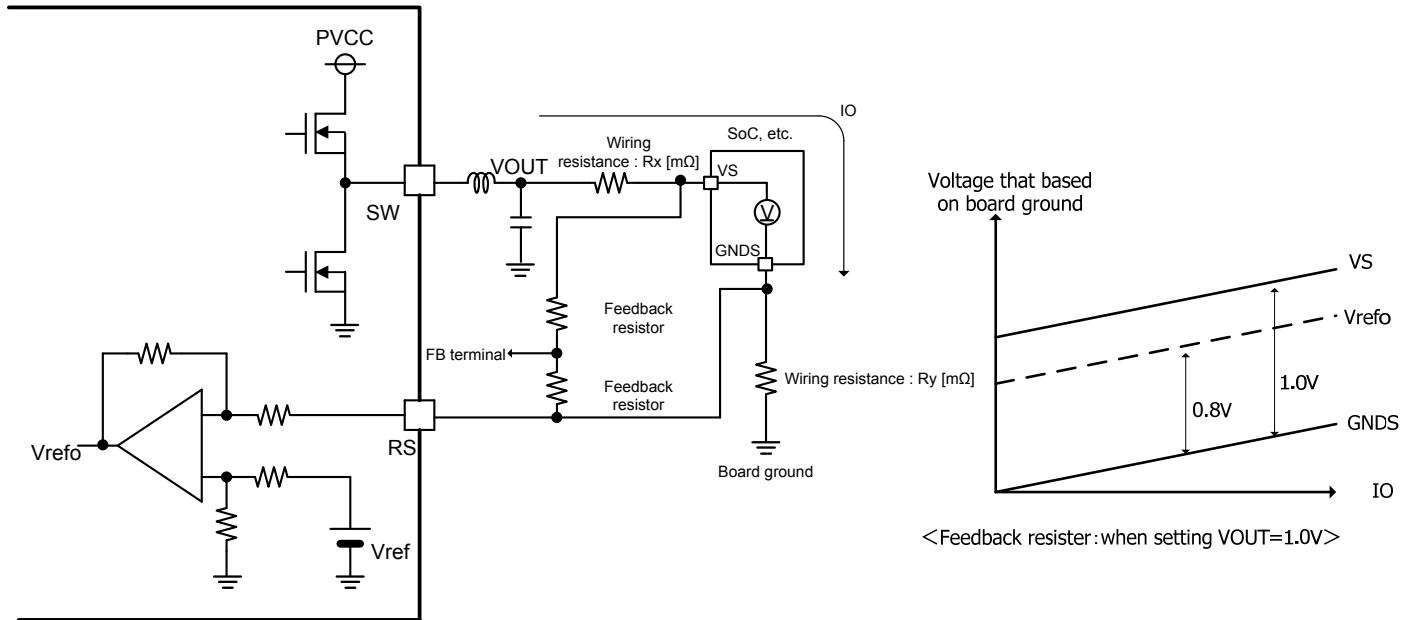

Figure 38. Remote sense

Switching Regulator Efficiency

$$\eta = \frac{VOUT \times IOUT}{VIN \times IIN} \times 100[\%] = \frac{POUT}{PIN} \times 100[\%] = \frac{POUT}{POUT + PD\alpha} \times 100[\%]$$

Efficiency may be improved by reducing the switching regulator power dissipation factors PDα as follows:

Dissipation factors

1. ON resistance dissipation of inductor and FET :  $PD(I^2R)$  [W]
2. Gate charge/discharge dissipation :  $PD(Gate)$  [W]
3. Switching dissipation :  $PD(SW)$  [W]
4. ESR dissipation of capacitor :  $PD(ESR)$  [W]
5. Operating current dissipation of IC :  $PD(IC)$  [W]

$$(1) PD(I^2R) = IOUT^2 \times (RCOIL + RON) \text{ [W]}$$

(RCOIL [Ω] : DC resistance of inductor, RON [Ω] : ON resistance of FET, IOUT [A] : Output current)

$$(2) PD(Gate) = Cgs \times f \times V^2 \text{ [W]} \text{ (} Cgs \text{ [F] : Gate capacitance of FET, } f \text{ [Hz] : Switching frequency, } V \text{ [V] : Gate driving voltage of FET)}$$

$$(3) PD(SW) = \frac{VIN^2 \times Crss \times IOUT \times f}{IDRIVE} \text{ [W]} \text{ (} Crss \text{ [F] : Reverse transfer capacitance of FET, } IDRIVE \text{ [A] : Peak current of gate)}$$

$$(4) PD(ESR) = Irms^2 \times ESR \text{ [W]} \text{ (} Irms \text{ [Arms] : Ripple current of capacitor, } ESR \text{ [Ω] : Equivalent series resistance)}$$

$$(5) PD(IC) = VIN \times ICC \text{ [W]} \text{ (} ICC \text{ [A] : Circuit current)}$$

Consideration on Permissible Dissipation and Heat Generation

Since this IC functions with high efficiency without significant heat generation in most applications, no special consideration is needed on permissible dissipation or heat generation. In case of extreme conditions, however, including lower input voltage, higher output voltage, heavier load, and/or higher temperature, the permissible dissipation and/or heat generation must be carefully considered.

For dissipation, only conduction losses due to DC resistance of inductor and ON resistance of FET are considered because the conduction losses are the most significant among other dissipation mentioned above, such as gate charge/discharge dissipation and switching dissipation.

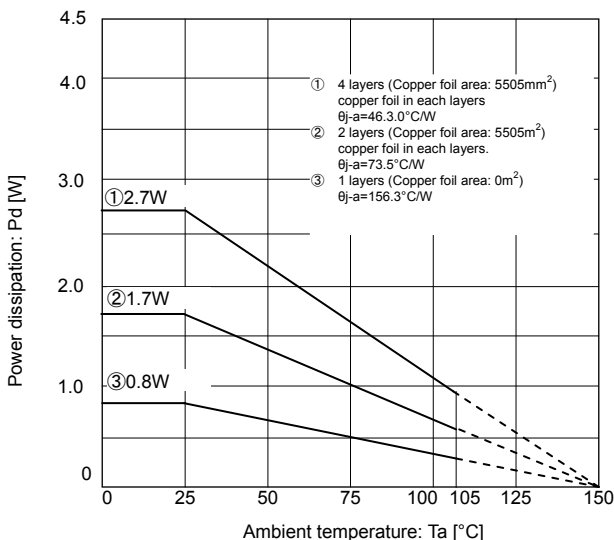

Figure 39. Thermal derating curve (VQFN20U4040M)

$$P = IOUT^2 \times RON \text{ [W]}$$

$$RON = D \times RONH + (1 - D) \times RONL \text{ [Ω]}$$

D: ON duty (=VOUT/VCC)  
 RONH: ON resistance of Highside MOSFET [Ω]  
 RONL: ON resistance of Lowside MOSFET [Ω]  
 IOUT: Output current [A]

Ex) When in VCC=5V, VOUT=1V, RONH=27mΩ, RONL=27mΩ, IOUT=5A

$$\text{By } D = VOUT/VCC = 1/5 = 0.2$$

$$RON = 0.2 \times 0.027 + (1 - 0.2) \times 0.027 = 0.0054 + 0.0216$$

$$= 0.027 \text{ [Ω]}$$

$$P = 5^2 \times 0.027 = 0.675 \text{ [W]}$$

Thermal design must be carried out with sufficient margin allowed with consideration on the dissipation above.

External Component Selection

1. Inductor (L)

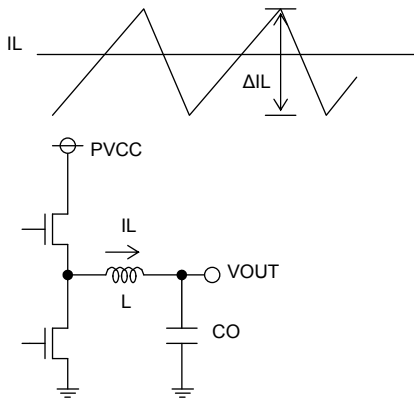

The inductance has great influence on the output ripple current. As seen in the equation (1), the ripple current decreases as the inductor and/or switching frequency increases.

$$\Delta IL = \frac{(VCC - VOUT) \times VOUT}{L \times VCC \times f} \quad [A] \dots (1)$$

f: Switching frequency [Hz]    ΔIL: Output ripple current [A]

Efficiency is affected as the dissipation factor, PD(I<sup>2</sup>R) [W], PD(Gate) [W], PD(SW) [W], changes with respect to the coil value and PFM frequency dependence on ripple current. BD91364BMUU is designed to have least dissipation in PFM and PWM, both about L = 0.33μH to 0.47μH.

Figure 40. Output ripple current

※Current flow that exceeds the coil rating brings the coil into magnetic saturation, which may lead to lower efficiency. Select an inductor with an adequate margin so that the peak current does not exceed the rated current of the coil. In addition, select a coil with a low resistance component (DCR, ACR) to lessen coil dissipation and improve efficiency.

2. Output Capacitor (CO)

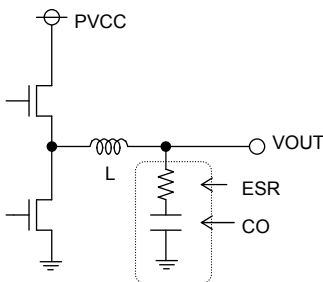

Figure 41. Output capacitor

Output capacitor should be selected with the consideration on the stability region and the equivalent series resistance required for smooth ripple voltage.

Output ripple voltage is determined by the equation (2):

$$\Delta VOUT = \Delta IL \times ESR \quad [V] \dots (2)$$

ΔIL: output ripple current [A]    ESR: Equivalent series resistance of CO [Ω]

※ There must be an adequate margin between the maximum rating and output voltage of the capacitor. against output voltage. A 22μF to 100μF ceramic capacitor is recommended. A capacitor with low ESR is recommended order to reduce output ripple. If you connect many parallel ceramic capacitor(Low ESR) to Vout. ESR value is very small. Please careful interfere with noise signal.

Maximum value of CO must be considered as a large current is needed to charge CO to VOUT set point during boot-up. This current may trigger over current protection (OCP) and cause a normal boot-up failure.

$$TSS > \frac{CO \times VOUT}{IOCP} \quad [sec] \dots (3)$$

TSS: Soft start time [sec] (refer to Page10)

IOCP: Over current detection [A] (min) about 6.5A

3. Input Capacitor (CIN)

Input capacitor must be a low ESR capacitor with a capacitance sufficient to cope with high ripple current to prevent high transient voltage. The ripple current IRMS is given by the equation (4): Cin is recommended to 22µF.

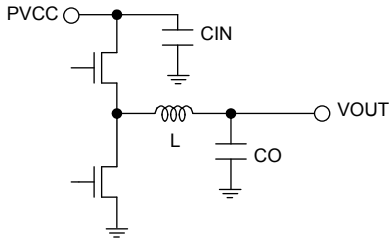

$$I_{rms} = I_{OUT} \times \frac{\sqrt{V_{OUT}(V_{CC} - V_{OUT})}}{V_{CC}} \quad [\text{Arms}] \dots (4)$$

<Worst case>  $I_{rms}[\text{Arms}](\text{max})$

When  $V_{CC} = 2 \times V_{OUT}$ ,  $I_{rms} = \frac{I_{OUT}}{2}$  [Arms]

Ex) BD91364BMUU When  $V_{CC}=5.5\text{V}$ ,  $V_{OUT}=2.75\text{V}$ ,  $I_{OUT\text{max}}=5\text{A}$

Figure 42. Input capacitor

$$I_{rms} = 5 \times \frac{\sqrt{2.75(5 - 2.75)}}{5.5} = 2.75 \quad [\text{Arms}]$$

4. Feedback Capacitor

FIX ONTIME control needs enough ripple voltage for stable feedback voltage comparator operation. This IC is designed to respond to low ESR output capacitor, such as ceramic capacitor, by injecting a ripple to the feedback voltage. In order to inject appropriate ripple, a feedback capacitor of 100pF to 200pF is recommended.

5. Output Voltage Determination

The output voltage VOUT is determined by the equation (5):

$$V_{OUT} = (R2/R1 + 1) \times V_{FB} \quad [\text{V}] \dots (5)$$

$V_{FB}$ :FB terminal voltage(0.8V Typ)

With R1 and R2 adjusted, the output voltage may be determined as required.

[ Output voltage setting range is 0.8V to  $PV_{CC} \times 0.8\text{V}$  ]

Use about 100kΩ resistor for R1 and R2 to consider loss at the PFM.

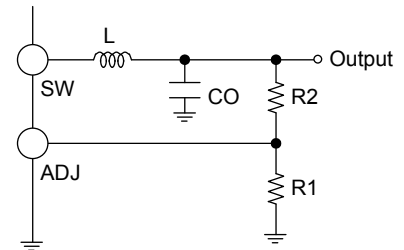

Figure 43. Output voltage setting resistor

<Caution when reducing input voltage>

Output voltage decreases below set value when input voltage is not sufficient. The decrease in output voltage is not only dependent on IC characteristics. It is also affected by the output load current and by the inductor's DCR.

Fig.39 shows output voltage condition when output voltage is Set to 3.3V and input voltage is lowered in varying load current condition (L=FDSD0420-H-R47 : DCR=15mΩ Typ).

Basically  $PV_{CC} \times 0.8 \geq V_{OUT}$  is set as specification range, but in case this condition is not satisfied, the output voltage goes lower than the set value like in Figure 44.

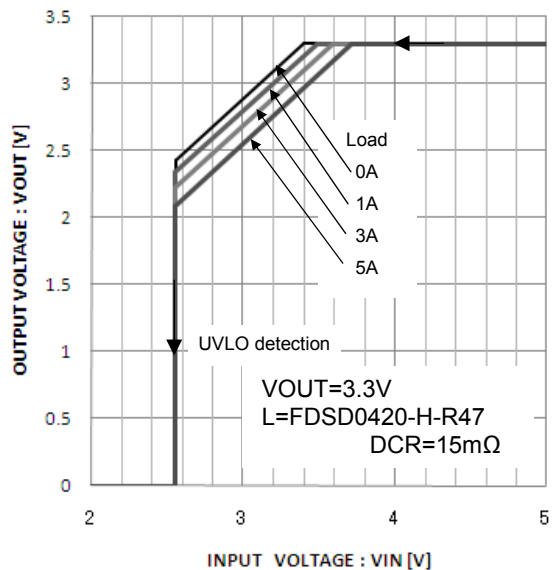

Figure 44. Output and input voltage difference limits

Application Information

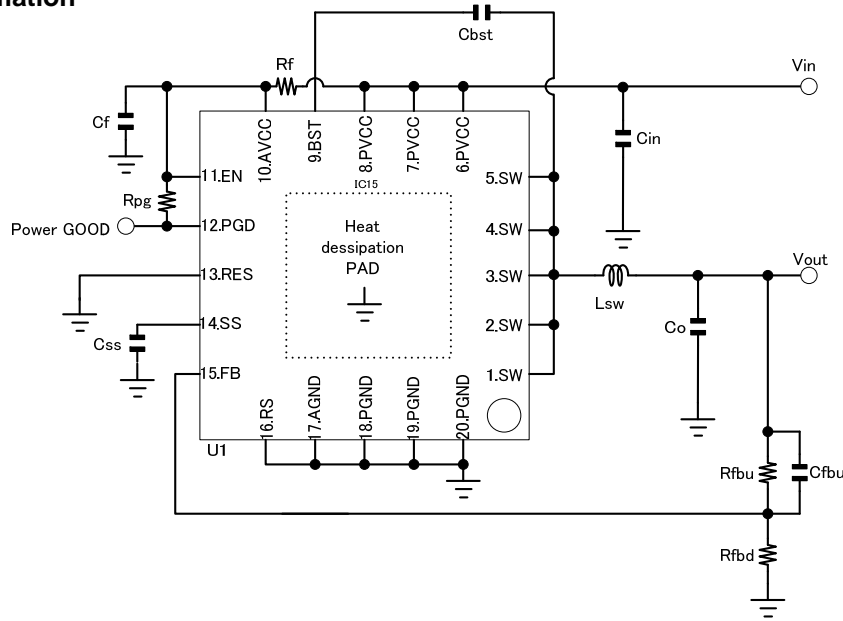

Figure 45. Recommended part circuit

1. pin 11, EN  
Provide control signal externally when controlling the output via enable terminal.
2. pin 13, RES  
Connect to ground.
3. pin 16, RS  
Connect RS to ground sense point when using remote sense function.  
Connect to AGND(Ground) if not in use.
4. Rpg  
Pull-up resistor for Power GOOD function.  
Keep pin 12(PGD) open or connect it to ground when Power GOOD function is not in use.
5. C<sub>SS</sub>  
Capacitors for soft start time setting.  
A default 1msec soft start time is set if pin 14(SS) is left open.

Recommendation parts list

Part No	Value	Manufacturer	Part number
U1	-	ROHM	BD91364BMUU
L <sub>SW</sub>	0.47μH	TOKO	FDSD0420-H-R47M
C <sub>O</sub>	22μF	MURATA	GRM32ER61E226
C <sub>in</sub> (Note6)	22μF	MURATA	GRM21BR60J226
C <sub>bst</sub>	0.1μF	MURATA	GRM15 Series 1005
C <sub>SS</sub>	1000pF	MURATA	GRM15 Series 1005
C <sub>fbu</sub>	200pF	MURATA	GRM15 Series 1005
C <sub>f</sub>	1000pF	MURATA	GRM15 Series 1005
R <sub>fbd</sub>	200kΩ	ROHM	MCR01 Series 1005
R <sub>fbu</sub>	51kΩ	ROHM	MCR01 Series 1005
R <sub>f</sub>	100Ω	ROHM	MCR01 Series 1005
R <sub>pg</sub>	100kΩ	ROHM	MCR01 Series 1005

(Note6) For capacitance of input capacitor take temperature characteristics, DC bias characteristics, etc. into consideration to set minimum value to no less than 10μF.

Notes for PCB Layout

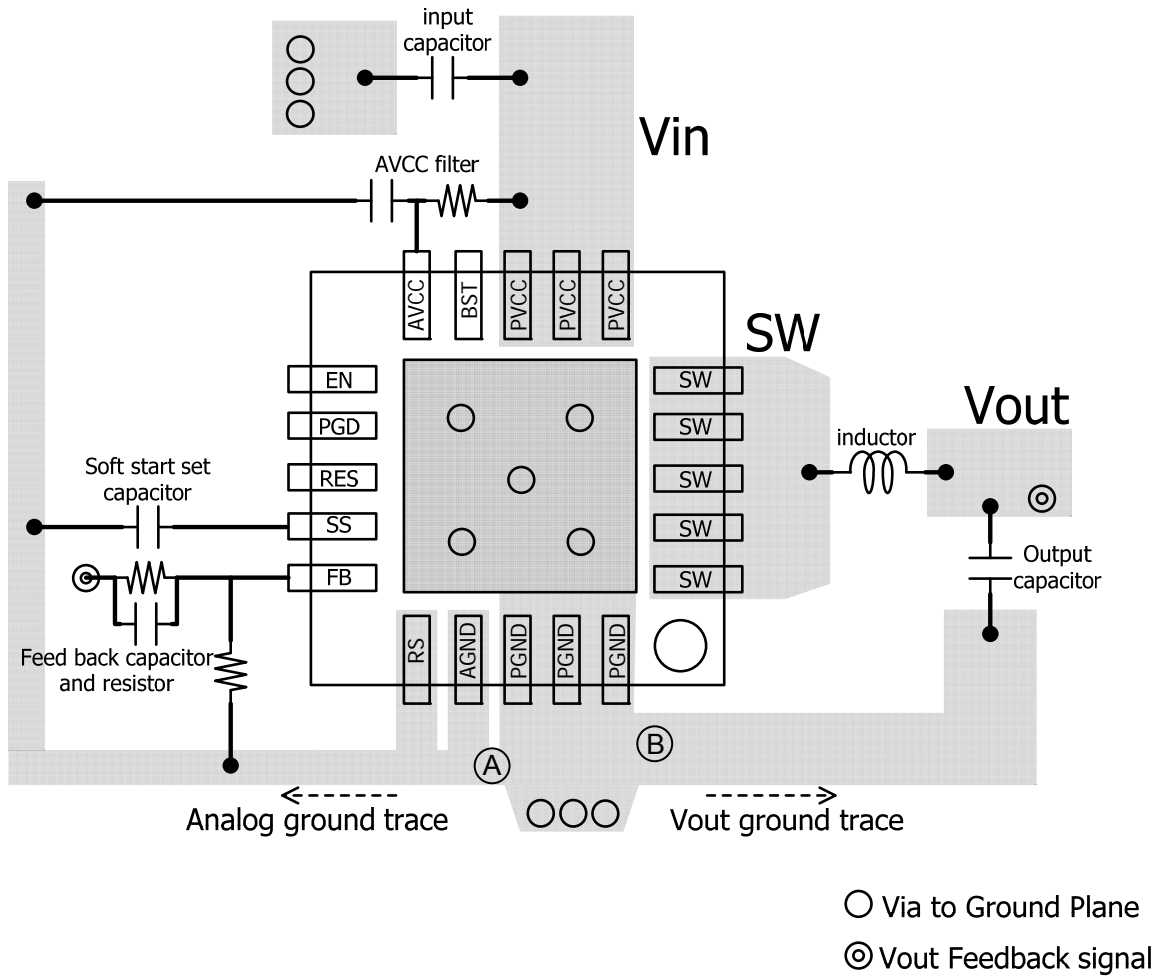

Figure 46. PCB layout

Ground sense interconnection should be carefully placed as input capacitors generate a large transient current. Connect analog ground pin, AGND, to ground plane at point (A) as shown in Fig.46 to prevent high current from passing through the analog ground trace. Vout ground, which carries a transient current, should be connected to ground plane at point (B). And Feed back capacitor and resistor are arranged trace nearly FB input pin. And please be careful Feed back LINE arranged trace for interfering with noise signal.

I/O equivalence circuit

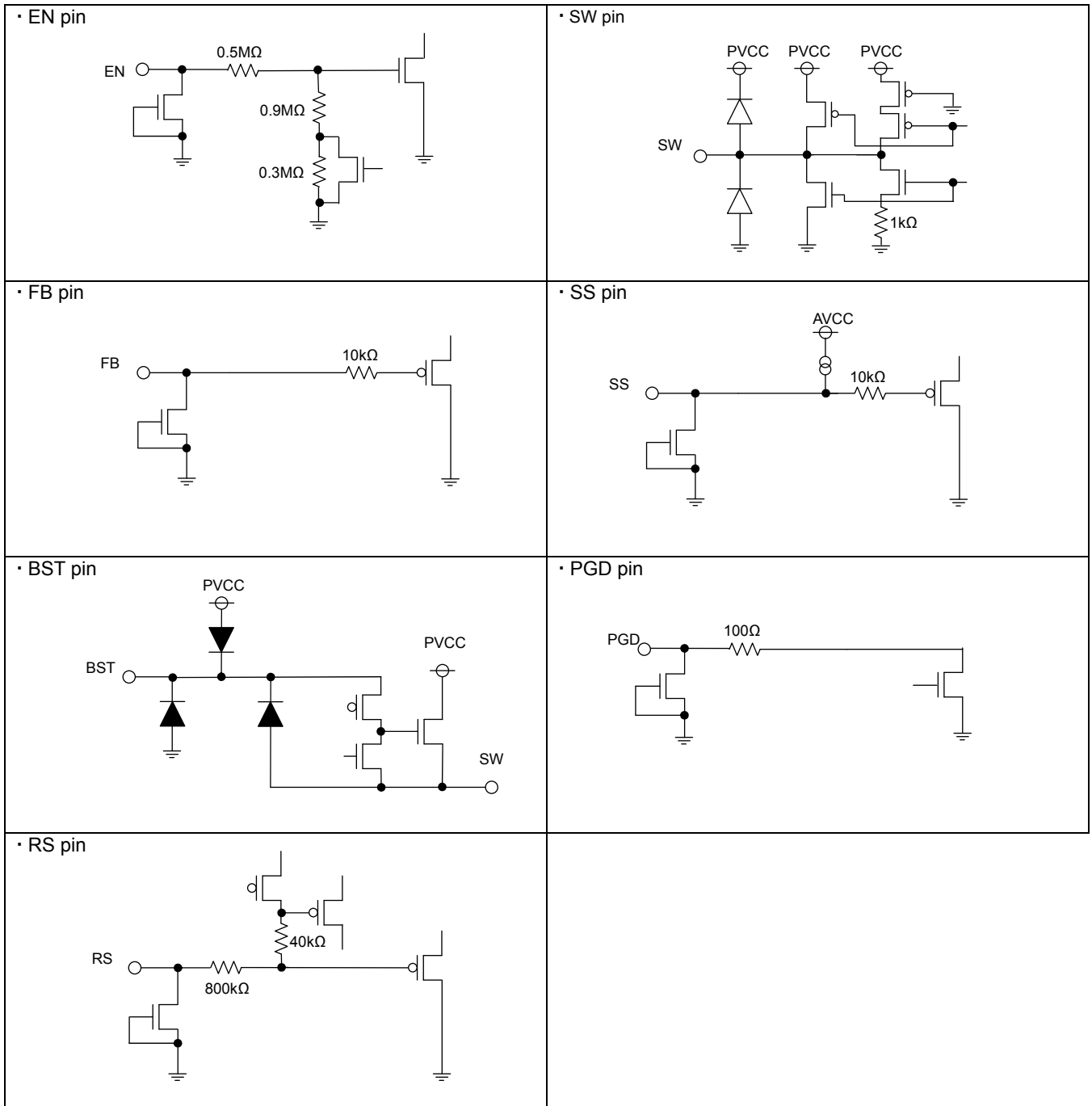

Figure 47. I/O equivalence circuit

## Operational Notes

### 1. Reverse Connection of Power Supply

Connecting the power supply in reverse polarity can damage the IC. Take precautions against reverse polarity when connecting the power supply, such as mounting an external diode between the power supply and the IC's power supply pins.

### 2. Power Supply Lines

Design the PCB layout pattern to provide low impedance supply lines. Separate the ground and supply lines of the digital and analog blocks to prevent noise in the ground and supply lines of the digital block from affecting the analog block. Furthermore, connect a capacitor to ground at all power supply pins. Consider the effect of temperature and aging on the capacitance value when using electrolytic capacitors.

### 3. Ground Voltage

Ensure that no pins are at a voltage below that of the ground pin at any time, even during transient condition.

OR

### 4. Ground Wiring Pattern

When using both small-signal and large-current ground traces, the two ground traces should be routed separately but connected to a single ground at the reference point of the application board to avoid fluctuations in the small-signal ground caused by large currents. Also ensure that the ground traces of external components do not cause variations on the ground voltage. The ground lines must be as short and thick as possible to reduce line impedance.

### 5. Thermal Consideration

Should by any chance the power dissipation rating be exceeded the rise in temperature of the chip may result in deterioration of the properties of the chip. The absolute maximum rating of the Pd stated in this specification is when the IC is mounted on a 70mm x 70mm x 1.6mm glass epoxy board. In case of exceeding this absolute maximum rating, increase the board size and copper area to prevent exceeding the Pd rating.

### 6. Recommended Operating Conditions

These conditions represent a range within which the expected characteristics of the IC can be approximately obtained. The electrical characteristics are guaranteed under the conditions of each parameter.

### 7. Inrush Current

When power is first supplied to the IC, it is possible that the internal logic may be unstable and inrush current may flow instantaneously due to the internal powering sequence and delays, especially if the IC has more than one power supply. Therefore, give special consideration to power coupling capacitance, power wiring, width of ground wiring, and routing of connections.

### 8. Operation Under Strong Electromagnetic Field

Operating the IC in the presence of a strong electromagnetic field may cause the IC to malfunction.

### 9. Testing on Application Boards

When testing the IC on an application board, connecting a capacitor directly to a low-impedance output pin may subject the IC to stress. Always discharge capacitors completely after each process or step. The IC's power supply should always be turned off completely before connecting or removing it from the test setup during the inspection process. To prevent damage from static discharge, ground the IC during assembly and use similar precautions during transport and storage.

### 10. Inter-pin Short and Mounting Errors

Ensure that the direction and position are correct when mounting the IC on the PCB. Incorrect mounting may result in damaging the IC. Avoid nearby pins being shorted to each other especially to ground, power supply and output pin. Inter-pin shorts could be due to many reasons such as metal particles, water droplets (in very humid environment) and unintentional solder bridge deposited in between pins during assembly to name a few.

## Operational Notes – continued

**11. Unused Input Pins**

Input pins of an IC are often connected to the gate of a MOS transistor. The gate has extremely high impedance and extremely low capacitance. If left unconnected, the electric field from the outside can easily charge it. The small charge acquired in this way is enough to produce a significant effect on the conduction through the transistor and cause unexpected operation of the IC. So unless otherwise specified, unused input pins should be connected to the power supply or ground line.

**12. Regarding the Input Pin of the IC**

This monolithic IC contains P+ isolation and P substrate layers between adjacent elements in order to keep them isolated. P-N junctions are formed at the intersection of the P layers with the N layers of other elements, creating a parasitic diode or transistor. For example (refer to figure below):

When  $GND > Pin A$  and  $GND > Pin B$ , the P-N junction operates as a parasitic diode.  
When  $GND > Pin B$ , the P-N junction operates as a parasitic transistor.

Parasitic diodes inevitably occur in the structure of the IC. The operation of parasitic diodes can result in mutual interference among circuits, operational faults, or physical damage. Therefore, conditions that cause these diodes to operate, such as applying a voltage lower than the GND voltage to an input pin (and thus to the P substrate) should be avoided.

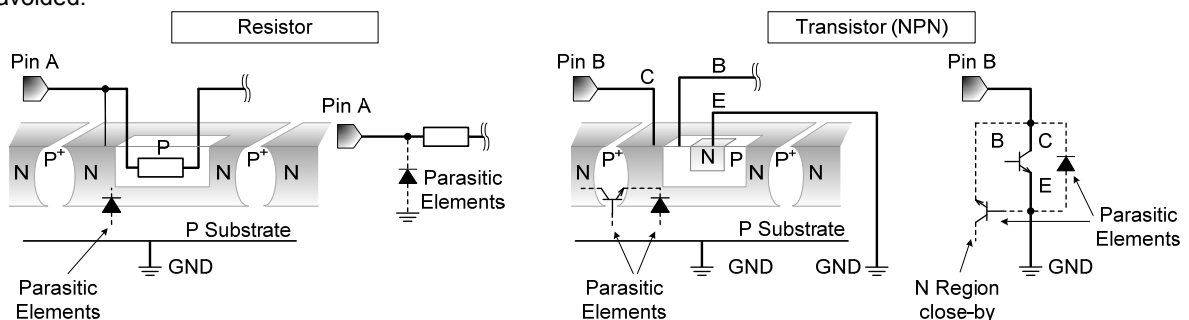

Figure 48. Example of monolithic IC structure

**13. Ceramic Capacitor**

When using a ceramic capacitor, determine the dielectric constant considering the change of capacitance with temperature and the decrease in nominal capacitance due to DC bias and others.

**14. Area of Safe Operation (ASO)**

Operate the IC such that the output voltage, output current, and power dissipation are all within the Area of Safe Operation (ASO).

**15. Thermal Shutdown Circuit(TSD)**

This IC has a built-in thermal shutdown circuit that prevents heat damage to the IC. Normal operation should always be within the IC's power dissipation rating. If however the rating is exceeded for a continued period, the junction temperature ( $T_j$ ) will rise which will activate the TSD circuit that will turn OFF all output pins. When the  $T_j$  falls below the TSD threshold, the circuits are automatically restored to normal operation.

Note that the TSD circuit operates in a situation that exceeds the absolute maximum ratings and therefore, under no circumstances, should the TSD circuit be used in a set design or for any purpose other than protecting the IC from heat damage.

**16. Over Current Protection Circuit (OCP)**

This IC incorporates an integrated overcurrent protection circuit that is activated when the load is shorted. This protection circuit is effective in preventing damage due to sudden and unexpected incidents. However, the IC should not be used in applications characterized by continuous operation or transitioning of the protection circuit.

Ordering Information

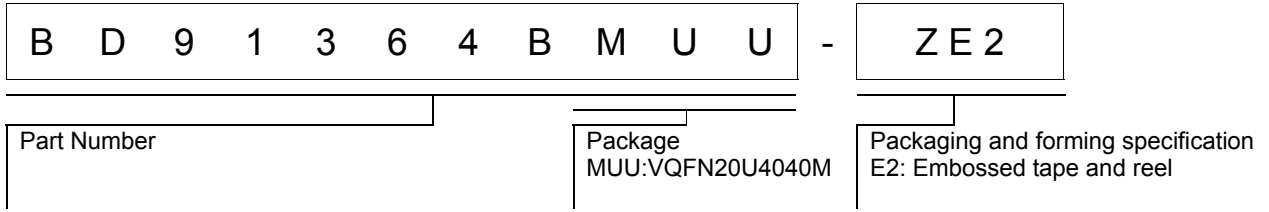

Marking Diagrams

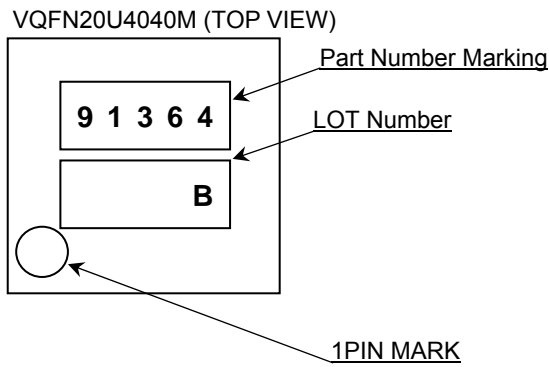



**Revision History**

Date	Revision	Changes
27.Jul.2015	001	New Release

# Notice

## Precaution on using ROHM Products

- Our Products are designed and manufactured for application in ordinary electronic equipments (such as AV equipment, OA equipment, telecommunication equipment, home electronic appliances, amusement equipment, etc.). If you intend to use our Products in devices requiring extremely high reliability (such as medical equipment <sup>(Note 1)</sup>, transport equipment, traffic equipment, aircraft/spacecraft, nuclear power controllers, fuel controllers, car equipment including car accessories, safety devices, etc.) and whose malfunction or failure may cause loss of human life, bodily injury or serious damage to property ("Specific Applications"), please consult with the ROHM sales representative in advance. Unless otherwise agreed in writing by ROHM in advance, ROHM shall not be in any way responsible or liable for any damages, expenses or losses incurred by you or third parties arising from the use of any ROHM's Products for Specific Applications.

(Note1) Medical Equipment Classification of the Specific Applications

JAPAN	USA	EU	CHINA
CLASS III	CLASS III	CLASS II b	CLASS III
CLASS IV		CLASS III	

- ROHM designs and manufactures its Products subject to strict quality control system. However, semiconductor products can fail or malfunction at a certain rate. Please be sure to implement, at your own responsibilities, adequate safety measures including but not limited to fail-safe design against the physical injury, damage to any property, which a failure or malfunction of our Products may cause. The following are examples of safety measures:
  - Installation of protection circuits or other protective devices to improve system safety
  - Installation of redundant circuits to reduce the impact of single or multiple circuit failure
- Our Products are designed and manufactured for use under standard conditions and not under any special or extraordinary environments or conditions, as exemplified below. Accordingly, ROHM shall not be in any way responsible or liable for any damages, expenses or losses arising from the use of any ROHM's Products under any special or extraordinary environments or conditions. If you intend to use our Products under any special or extraordinary environments or conditions (as exemplified below), your independent verification and confirmation of product performance, reliability, etc. prior to use, must be necessary:
  - Use of our Products in any types of liquid, including water, oils, chemicals, and organic solvents
  - Use of our Products outdoors or in places where the Products are exposed to direct sunlight or dust
  - Use of our Products in places where the Products are exposed to sea wind or corrosive gases, including Cl<sub>2</sub>, H<sub>2</sub>S, NH<sub>3</sub>, SO<sub>2</sub>, and NO<sub>2</sub>
  - Use of our Products in places where the Products are exposed to static electricity or electromagnetic waves
  - Use of our Products in proximity to heat-producing components, plastic cords, or other flammable items
  - Sealing or coating our Products with resin or other coating materials
  - Use of our Products without cleaning residue of flux (even if you use no-clean type fluxes, cleaning residue of flux is recommended); or Washing our Products by using water or water-soluble cleaning agents for cleaning residue after soldering
  - Use of the Products in places subject to dew condensation
- The Products are not subject to radiation-proof design.
- Please verify and confirm characteristics of the final or mounted products in using the Products.
- In particular, if a transient load (a large amount of load applied in a short period of time, such as pulse. is applied, confirmation of performance characteristics after on-board mounting is strongly recommended. Avoid applying power exceeding normal rated power; exceeding the power rating under steady-state loading condition may negatively affect product performance and reliability.
- De-rate Power Dissipation (Pd) depending on Ambient temperature (Ta). When used in sealed area, confirm the actual ambient temperature.
- Confirm that operation temperature is within the specified range described in the product specification.
- ROHM shall not be in any way responsible or liable for failure induced under deviant condition from what is defined in this document.

## Precaution for Mounting / Circuit board design

- When a highly active halogenous (chlorine, bromine, etc.) flux is used, the residue of flux may negatively affect product performance and reliability.
- In principle, the reflow soldering method must be used on a surface-mount products, the flow soldering method must be used on a through hole mount products. If the flow soldering method is preferred on a surface-mount products, please consult with the ROHM representative in advance.

For details, please refer to ROHM Mounting specification

**Precautions Regarding Application Examples and External Circuits**

1. If change is made to the constant of an external circuit, please allow a sufficient margin considering variations of the characteristics of the Products and external components, including transient characteristics, as well as static characteristics.
2. You agree that application notes, reference designs, and associated data and information contained in this document are presented only as guidance for Products use. Therefore, in case you use such information, you are solely responsible for it and you must exercise your own independent verification and judgment in the use of such information contained in this document. ROHM shall not be in any way responsible or liable for any damages, expenses or losses incurred by you or third parties arising from the use of such information.

**Precaution for Electrostatic**

This Product is electrostatic sensitive product, which may be damaged due to electrostatic discharge. Please take proper caution in your manufacturing process and storage so that voltage exceeding the Products maximum rating will not be applied to Products. Please take special care under dry condition (e.g. Grounding of human body / equipment / solder iron, isolation from charged objects, setting of Ionizer, friction prevention and temperature / humidity control).

**Precaution for Storage / Transportation**

1. Product performance and soldered connections may deteriorate if the Products are stored in the places where:
  - [a] the Products are exposed to sea winds or corrosive gases, including Cl<sub>2</sub>, H<sub>2</sub>S, NH<sub>3</sub>, SO<sub>2</sub>, and NO<sub>2</sub>
  - [b] the temperature or humidity exceeds those recommended by ROHM
  - [c] the Products are exposed to direct sunshine or condensation
  - [d] the Products are exposed to high Electrostatic
2. Even under ROHM recommended storage condition, solderability of products out of recommended storage time period may be degraded. It is strongly recommended to confirm solderability before using Products of which storage time is exceeding the recommended storage time period.
3. Store / transport cartons in the correct direction, which is indicated on a carton with a symbol. Otherwise bent leads may occur due to excessive stress applied when dropping of a carton.
4. Use Products within the specified time after opening a humidity barrier bag. Baking is required before using Products of which storage time is exceeding the recommended storage time period.

**Precaution for Product Label**

QR code printed on ROHM Products label is for ROHM's internal use only.

**Precaution for Disposition**

When disposing Products please dispose them properly using an authorized industry waste company.

**Precaution for Foreign Exchange and Foreign Trade act**

Since concerned goods might be fallen under listed items of export control prescribed by Foreign exchange and Foreign trade act, please consult with ROHM in case of export.

**Precaution Regarding Intellectual Property Rights**

1. All information and data including but not limited to application example contained in this document is for reference only. ROHM does not warrant that foregoing information or data will not infringe any intellectual property rights or any other rights of any third party regarding such information or data.
2. ROHM shall not have any obligations where the claims, actions or demands arising from the combination of the Products with other articles such as components, circuits, systems or external equipment (including software).
3. No license, expressly or implied, is granted hereby under any intellectual property rights or other rights of ROHM or any third parties with respect to the Products or the information contained in this document. Provided, however, that ROHM will not assert its intellectual property rights or other rights against you or your customers to the extent necessary to manufacture or sell products containing the Products, subject to the terms and conditions herein.

**Other Precaution**



1. This document may not be reprinted or reproduced, in whole or in part, without prior written consent of ROHM.
2. The Products may not be disassembled, converted, modified, reproduced or otherwise changed without prior written consent of ROHM.
3. In no event shall you use in any way whatsoever the Products and the related technical information contained in the Products or this document for any military purposes, including but not limited to, the development of mass-destruction weapons.
4. The proper names of companies or products described in this document are trademarks or registered trademarks of ROHM, its affiliated companies or third parties.

**General Precaution**

1. Before you use our Products, you are requested to carefully read this document and fully understand its contents. ROHM shall not be in any way responsible or liable for failure, malfunction or accident arising from the use of any ROHM's Products against warning, caution or note contained in this document.
2. All information contained in this document is current as of the issuing date and subject to change without any prior notice. Before purchasing or using ROHM's Products, please confirm the latest information with a ROHM sales representative.
3. The information contained in this document is provided on an "as is" basis and ROHM does not warrant that all information contained in this document is accurate and/or error-free. ROHM shall not be in any way responsible or liable for any damages, expenses or losses incurred by you or third parties resulting from inaccuracy or errors of or concerning such information.

## Looking for pricing, stock, or lifecycle information?

Click below to explore more details on WIN SOURCE:

-  [View BD91364BMUU-ZE2 on WIN SOURCE](#)
-  [Rohm Semiconductor](#) Information

## Optimize Your Supply Chain with WIN SOURCE Solutions

-  Global Sourcing Solution
-  Obsolete Management
-  Cost Control Management
-  Shortage Management
-  Alternative Solution
-  Excess Inventory Management